



# PROJECT PLANS

## OUTDOOR SERVING CART



Make outdoor entertaining easy with this serving cart. It offers lots of space for storing food, tableware, and outdoor supplies, plus it cradles bottles where they're easy to reach but protected from spills. The top "shelf" is a lift-off tray, so you can carry supplies from the cart to your table.

The entire cart is built from pine 1x2 and 2x2 boards. Pine might not be the first wood you think of for outdoor use. We chose pine because the better grades look great, and tend to be crisper and straighter than similarly sized cedar boards. Just add a good-quality finish, and don't leave the cart sitting out in the weather for months on end, and it will serve you well for years.



## Safety:

Attention: Almost any do-it-yourself project involves risk of some sort. Your tools, materials, and skills will vary, as will the conditions at your project site. Kreg® Tool Company ("Kreg") has made every effort to be complete and accurate in the instructions and other content contained in this document. However, Kreg® will not assume any responsibility or liability for damages or losses sustained or incurred in the course of your project or in the use of the item you create. Always follow the manufacturer's operating instructions in the use of tools, check and follow your local building codes, and observe all commonly accepted safety precautions. We strive to be accurate, but reserve the right to correct any errors.

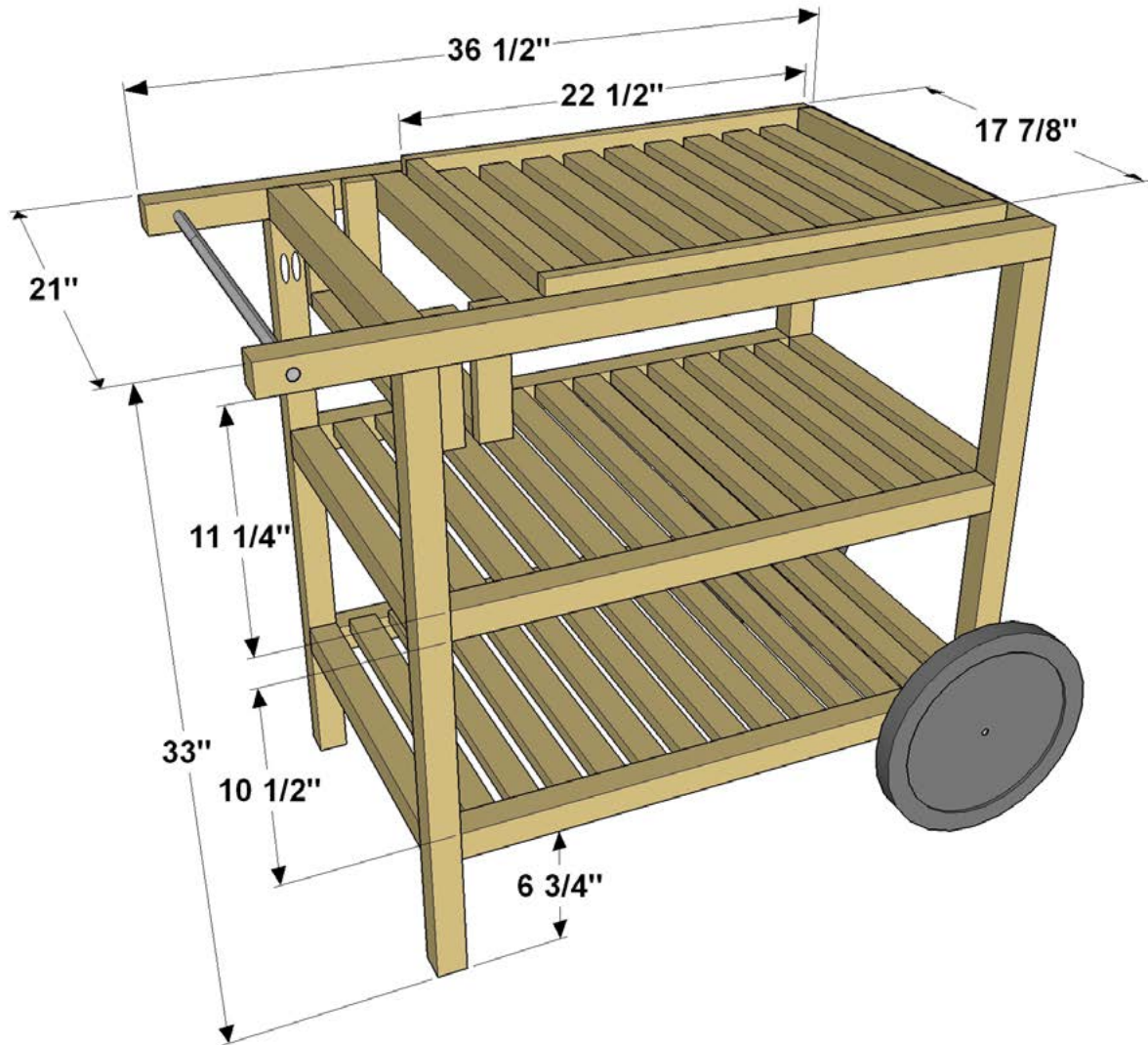

## Materials:

Qty	Description	Qty	Description
(8)	1x2 x 96" pine boards	(1)	3/8"-16 x 36" threaded rod
(1)	1x2 x 48" pine board	(2)	3/8"-16 acorn cap nut
(4)	2x2 x 96" pine boards	(1)	3/8"-16 standard nut (optional)
(1)	2x2 x 72" pine board	(4)	1/2" Fender Washer
(140)	1 1/4" exterior pocket hole screws	(2)	12" Steel Wheel
(76)	2 1/2" exterior pocket hole screws		wood glue
(1)	1/2" x 36" Aluminum Round Rod		clamps
(1)	1/2" x 36" Aluminum Tubing		wood finish
	(3/8" or greater inside diameter)		

## Tools:

Drill/Driver  
Kreg Jig®  
Miter Saw  
Hacksaw  
Tape Measure  
Sandpaper and Sander  
Square

### Optional Tools:

Kreg® Square-Cut™

# Cutting Diagram:

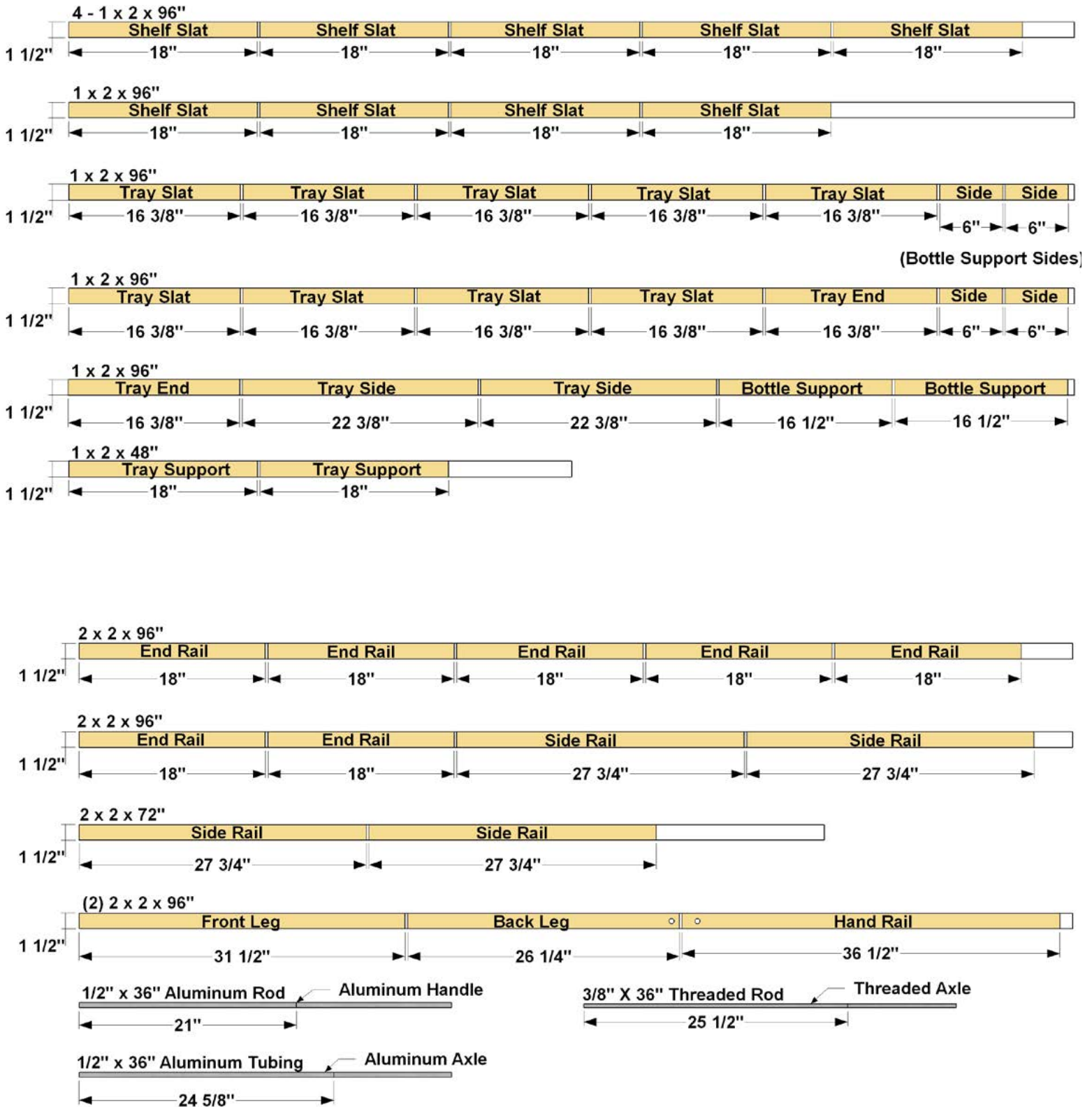

**Step 1:** Cut 24 Shelf Slats from 1x2 pine boards as shown in the cutting diagram. Set your pocket hole jig for 3/4" thick material, and then drill pocket holes in all of the Slats where shown.

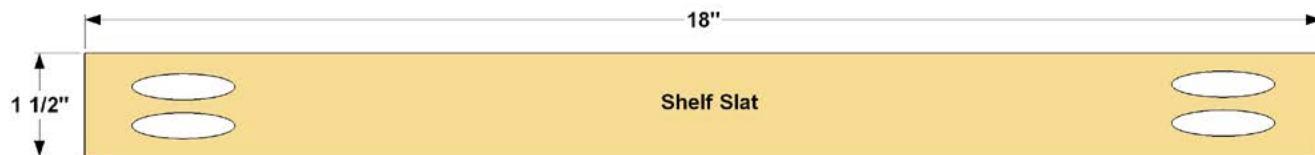

**Step 2:** Cut 4 Side Rails from 2x2 pine, as shown in the cutting diagram. Set your pocket hole jig for 1 1/2" thick material and drill pocket holes on the Side Rails where shown.

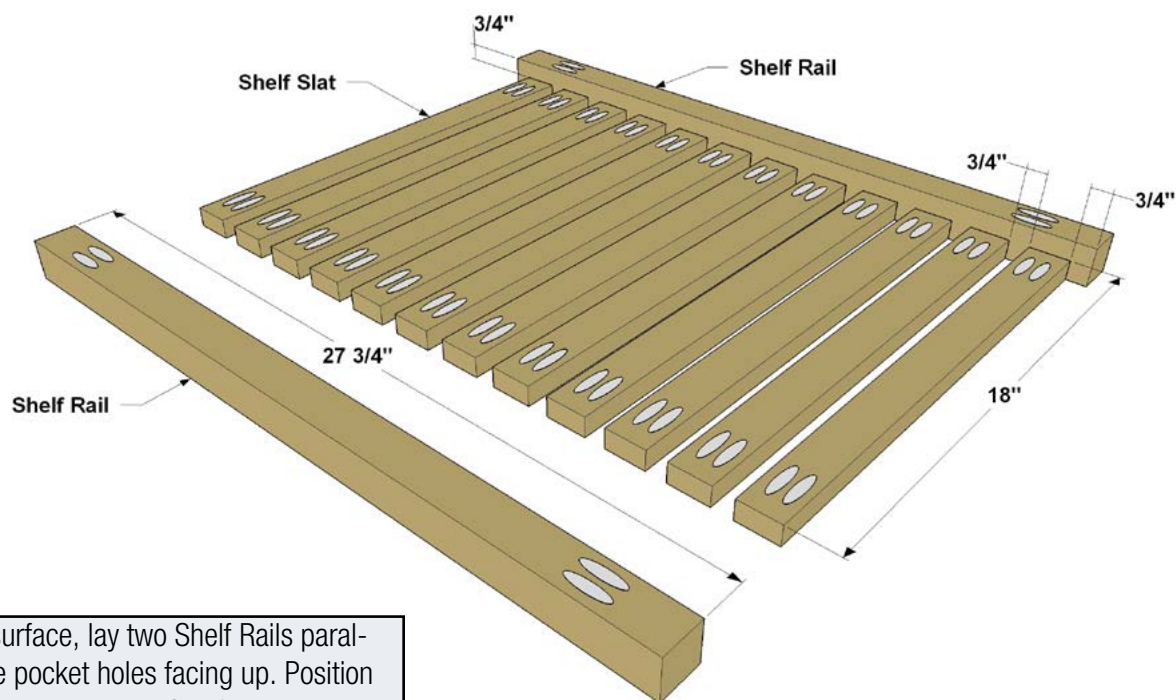

**Step 3:** On a flat work surface, lay two Shelf Rails parallel to one another with the pocket holes facing up. Position the first Shelf Slats perpendicular to the Shelf Rail and inset 3/4" from the edge. Secure the Slat to the Rail with 1 1/4" coarse-thread pocket hole screws. Space the next Slat 3/4" away and screw it in place. Secure the rest of the slats to one rail the same way. Use the same process for the second Rail as well as the second Shelf.



**Step 4:** Cut two Front Legs and two Back Legs to length from 2x2 boards, as shown in the cutting diagram. Set your pocket hole jig for 1 1/2" thick material and drill a single set of pocket holes on one end of the Front and Back Legs as shown.

**Step 5:** Place the two Back Legs together with the pocket holes face to face and temporarily tape the Back Legs together with painters tape. Mark the location of the 1/2" hole, and then drill through both Back Legs as shown.

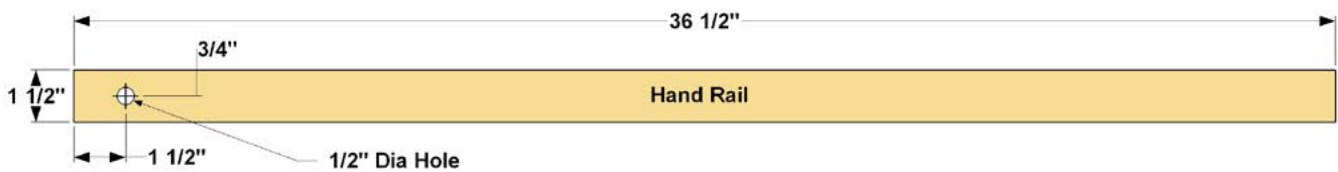

**Step 6:** Cut two Hand Rails to length from 2x2 pine boards, as shown in the cutting diagram. Tape the two Hand Rails together with painters tape, mark the location of the 1/2" hole, then drill through both Rails as shown.

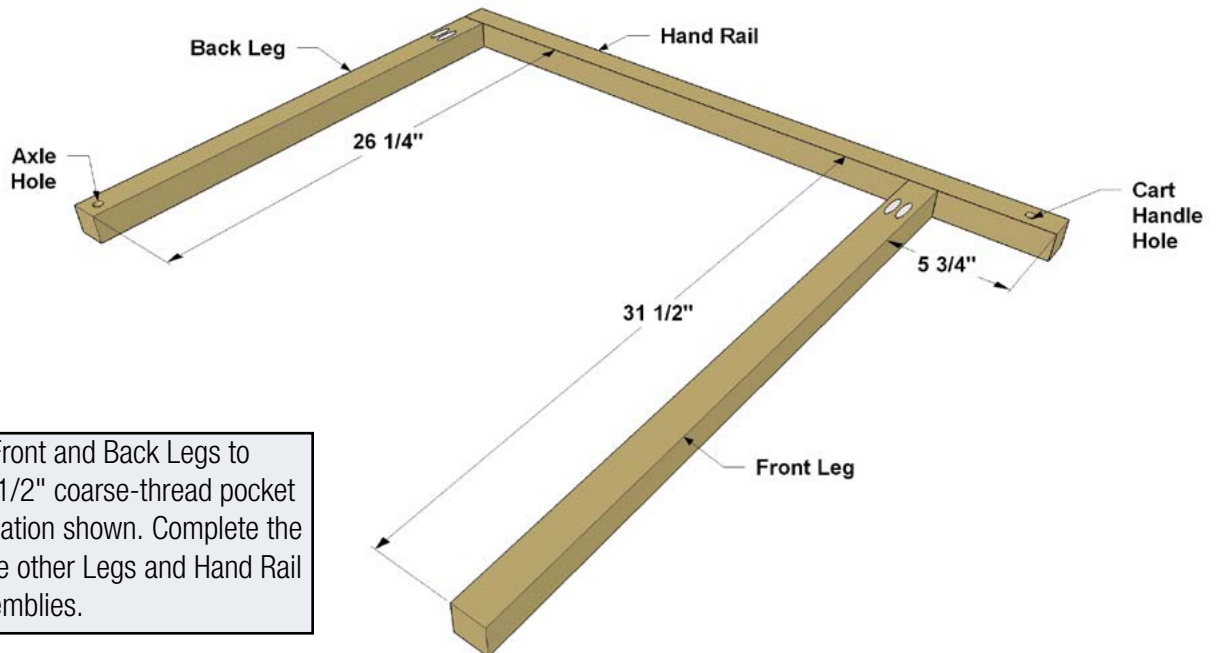

**Step 7:** Attach the Front and Back Legs to one Hand Rail with 2 1/2" coarse-thread pocket hole screws at the location shown. Complete the same operation for the other Legs and Hand Rail to create two leg assemblies.

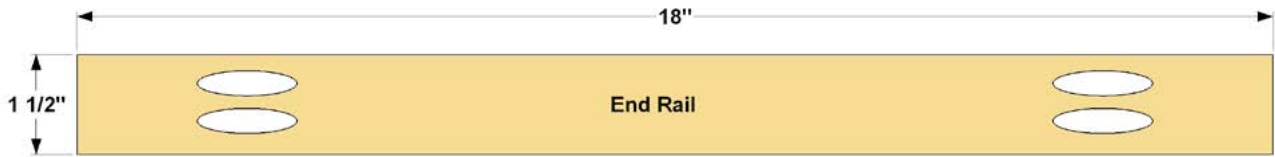

**Step 8:** Cut seven End Rails to length from 2x2 pine boards as shown in the cutting diagram. Set your pocket hole jig for 1 1/2" material, and then drill pocket holes in both ends of each Rail.

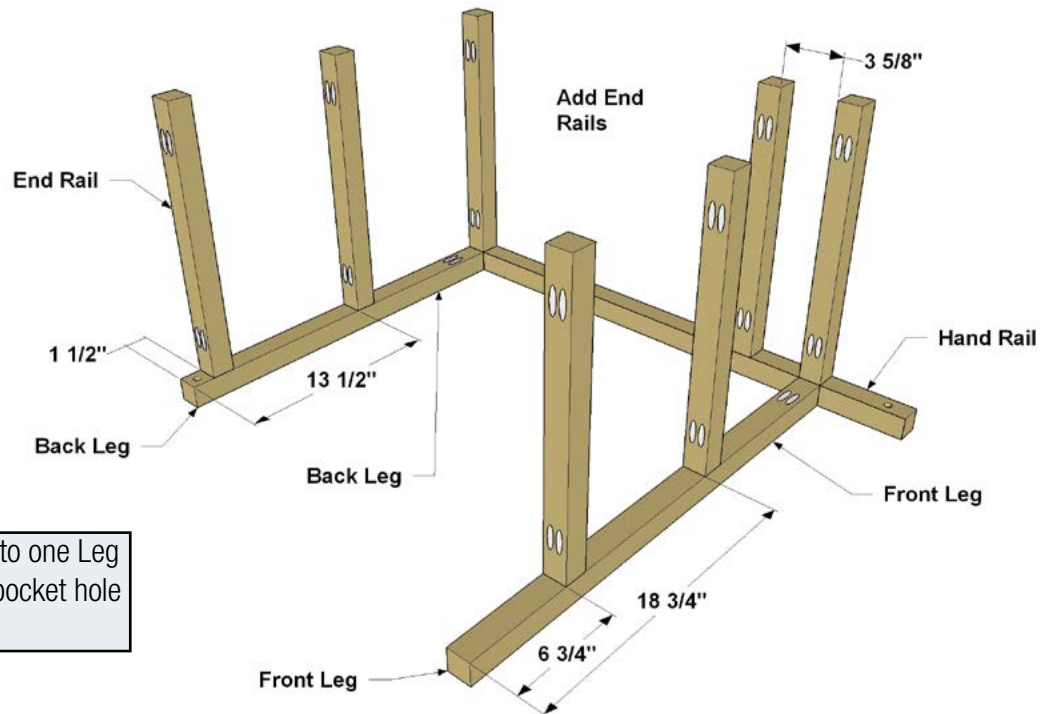

**Step 9:** Secure the seven End Rails to one Leg Assembly with 2 1/2" coarse-thread pocket hole screws at the locations shown.

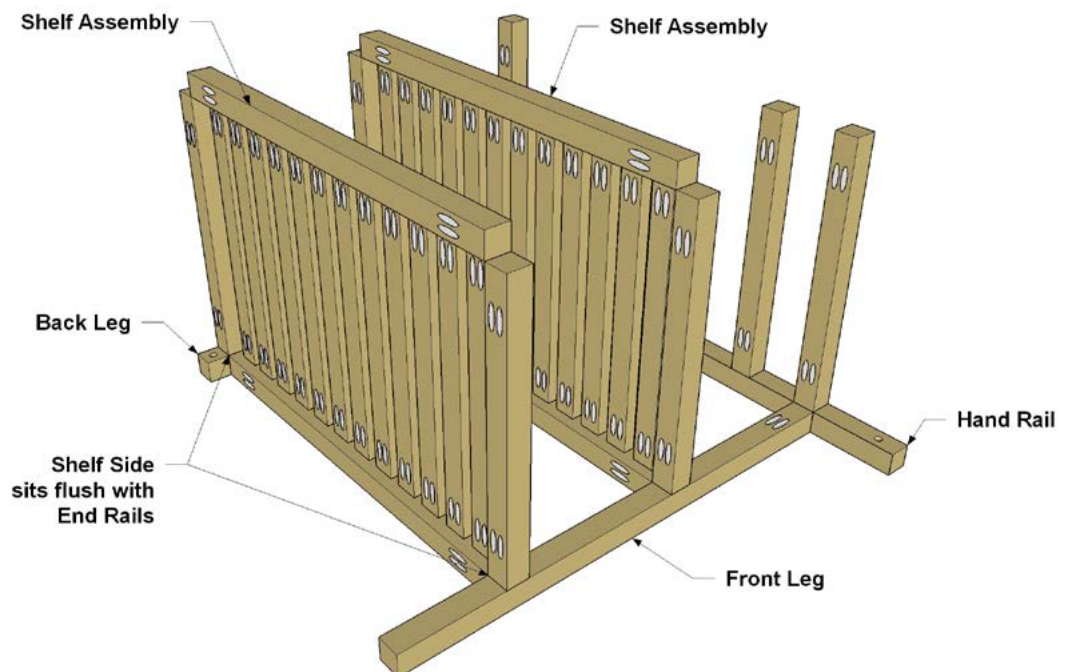

**Step 10:** Add the upper shelf assembly, and then the lower shelf assembly, to the leg assembly using 2 1/2" coarse-thread pocket hole screws as shown.

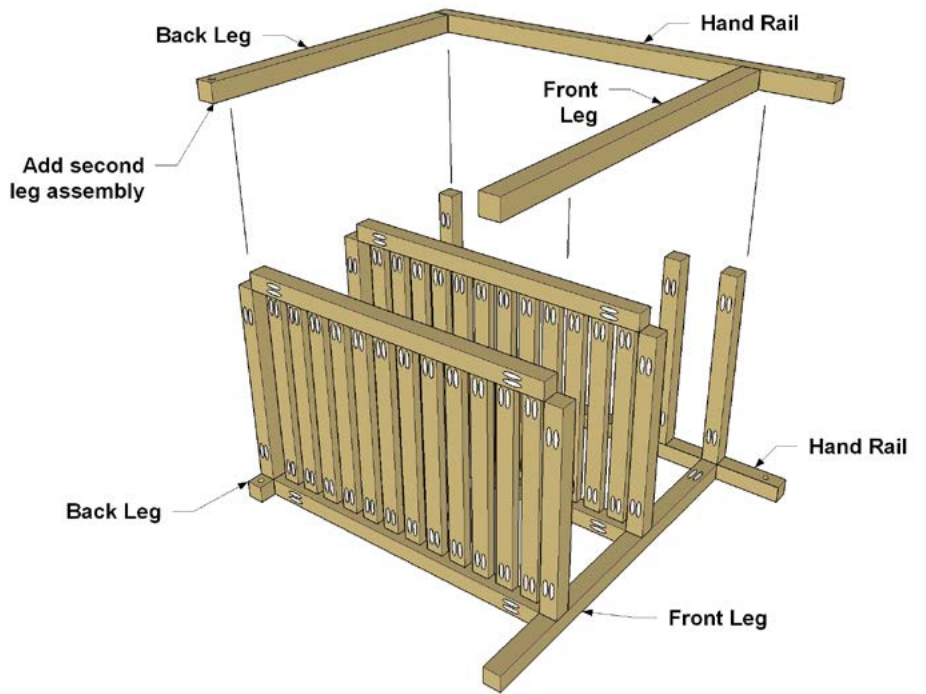

**Step 11:** Now add the second leg assembly and secure it with 2 1/2" coarse-thread pocket hole screws to complete the cart frame.

**Step 12:** Cut two Tray Supports, Two Bottle Support Bottoms and four Bottle Support Sides from 1x2 boards. Set your jig for 3/4" material and drill pocket holes in the Bottle Support Bottoms and the Tray Supports as shown.

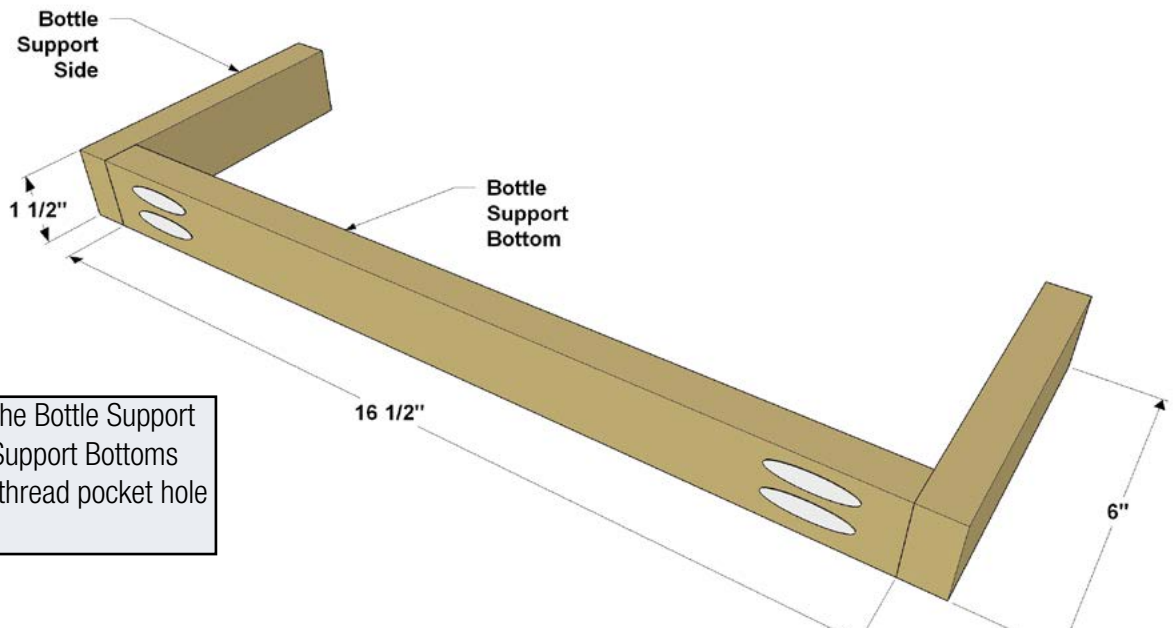
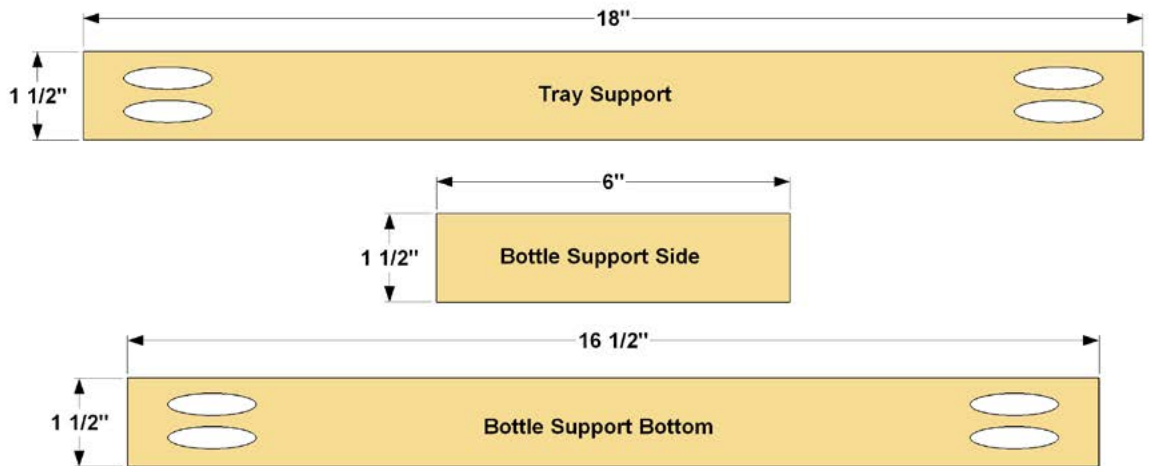

**Step 13:** Secure the Bottle Support Sides to the Bottle Support Bottoms with 1 1/4" coarse-thread pocket hole screws as shown.

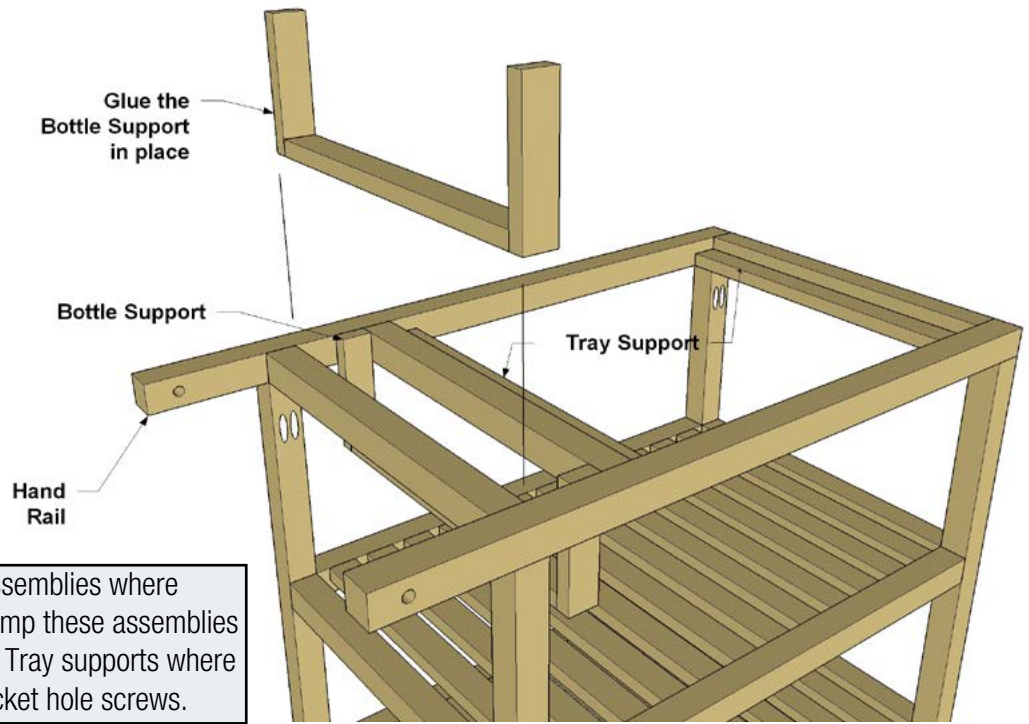

**Step 14:** Install the bottle support assemblies where shown and secure them with glue. Clamp these assemblies in place while the glue sets. Install the Tray supports where shown using 1 1/4" coarse-thread pocket hole screws.

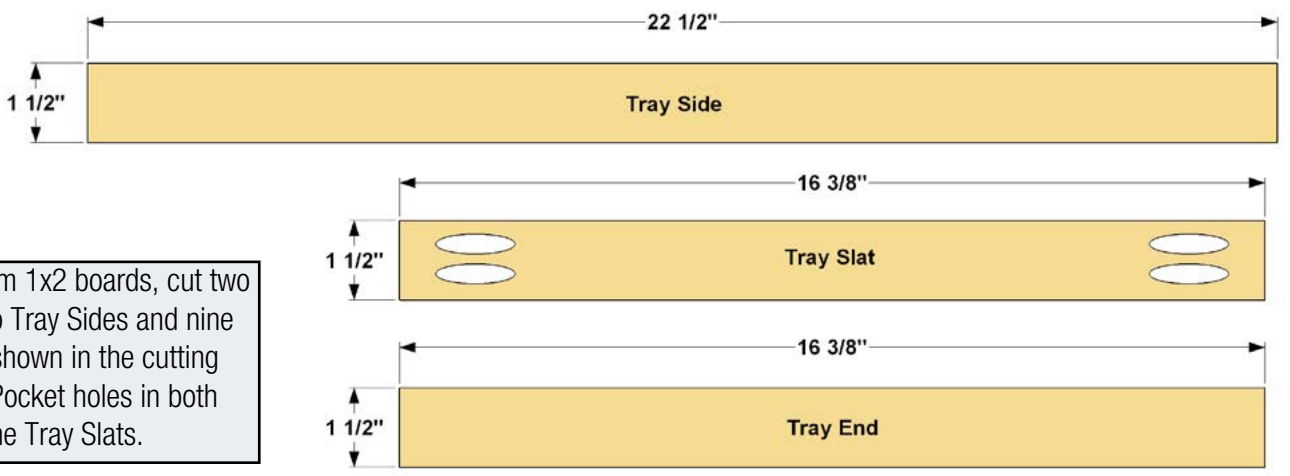

**Step 15:** From 1x2 boards, cut two Tray Ends, Two Tray Sides and nine Tray Slats, as shown in the cutting diagram. Drill Pocket holes in both ends in all of the Tray Slats.

**Step 16:** Position the Tray Slats as shown along one Tray Side, and then attach them using 1 1/4" coarse-thread pocket hole screws. Then attach the second Tray side the same way.

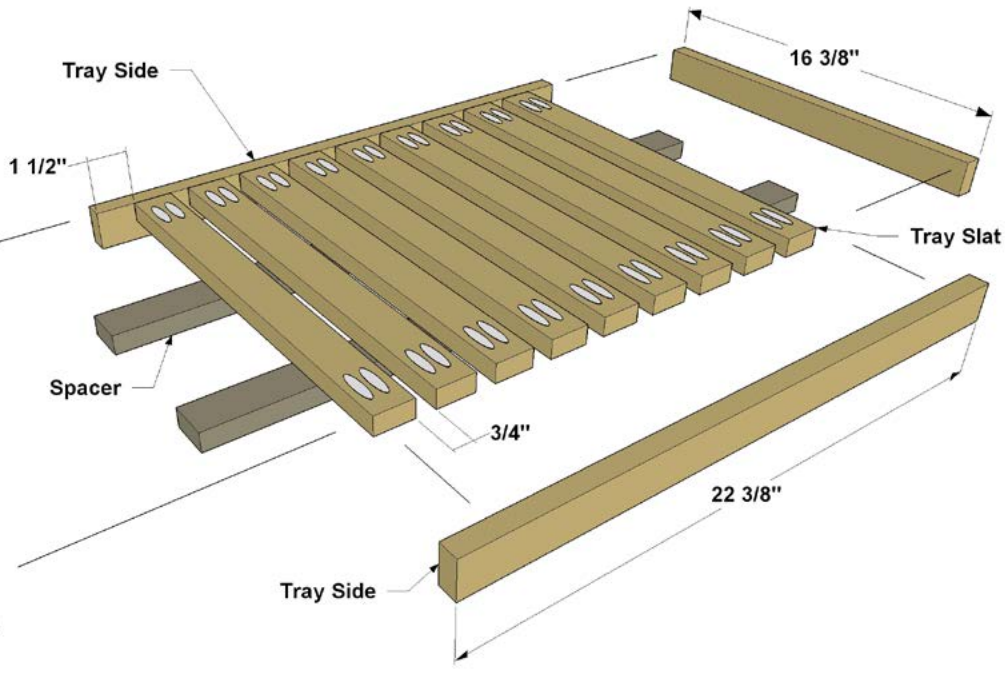

**Step 17:** When the Sides and Slats are assembled, dab a little glue on the ends of the Tray Ends, place them in position, and clamp them in place until the glue sets.

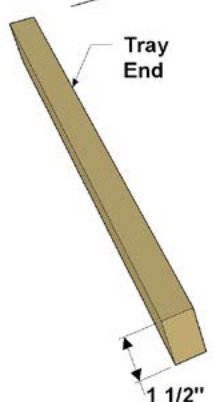



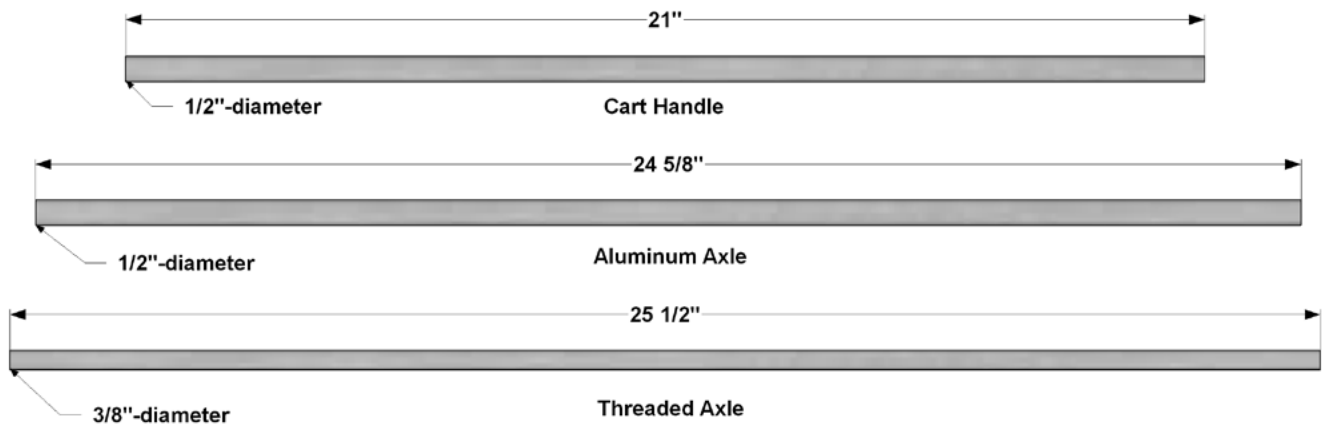

**Step 18:** Cut seven End Rails to length from 2x2 pine boards as shown in Use a hacksaw to cut the Cart Handle from 1/2" aluminum round bar Stock, the Aluminum Axle from 1/2" aluminum tubing, and the Treaded Axle from 3/8" threaded rod, as shown in the cutting diagram. Sand off any burrs and polish the Handle and the Aluminum Axle with a Scotch Brite pad.

**Step 19:** Install the Handle by sliding it through the holes in Hand Rails. If needed, use a little epoxy to secure the Handle in place.

**Step 20:** Slide the Aluminum Axle tube into the holes in the bottom of the Back Legs so they protrude past the Back Legs equally. Slide a fender washer over the each side of the tube, then add the wheels. Now, slide the Threaded Axle through the Aluminum Axle, and then add the other two fender washers. Finally, add the Cap Screw on each end of the Threaded Axle and tighten them so they are just snug.

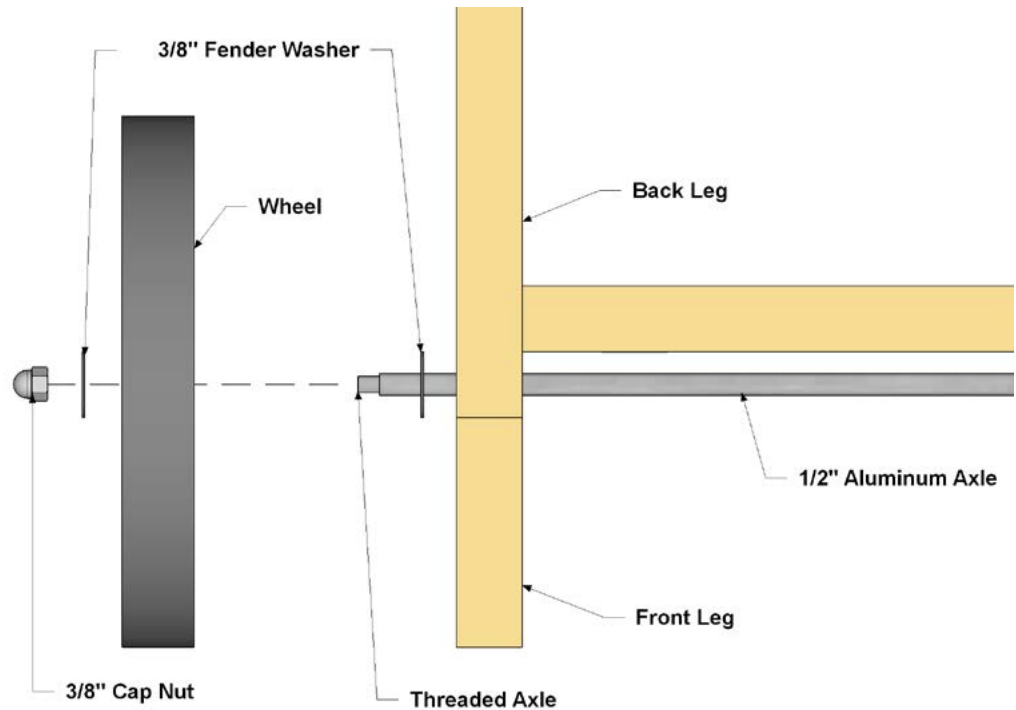

**Project Tip:** When you cut threaded rod with a hacksaw, the threading on the cut end can get damaged. A trick to restoring the threading is to screw a nut on to the rod before cutting the rod. Spin the nut out of the way of the cut, cut the rod to length, and then screw the nut off the cut end. This should restore the threading enough to get a nut back on the Cut end of the rod.

**Step 21:** Sand the cart smooth and soften any sharp edges with sandpaper. Then apply a finish. We used a natural oil to enhance the grain and color of the pine. Because the cart is made of pine, you probably want to park it indoors, or at least under an overhang, during bad weather. That will help it last longer. We also spray painted our wheels (which come painted white), and sprayed on some of the same color on the lower end of each Front Leg.