

Elevator Technology

# evolution

Low- to mid-rise elevator



thyssenkrupp





engineering.  
tomorrow.  
together.

### Making cities better.

Half of the world’s population now lives in cities. And urban populations are expected to grow by another 2.8 billion people by 2050.

To meet changing resident and business demands, cities need to adopt efficient urban planning and infrastructure development. They also need to create solutions for keeping people mobile in the midst of rapid growth.

As your urban mobility leader, thyssenkrupp Elevator is reshaping the elevator industry and transforming cities. We’re constantly evolving, with new products like MULTI, the first rope-less and horizontally moving elevator and MAX, the industry’s first cloud-based digitally enhanced maintenance solution.

To help customers and cities grow, we introduce evolution. It’s a low- to mid-rise elevator that combines safe and reliable performance, energy-efficient features and a hassle-free installation.

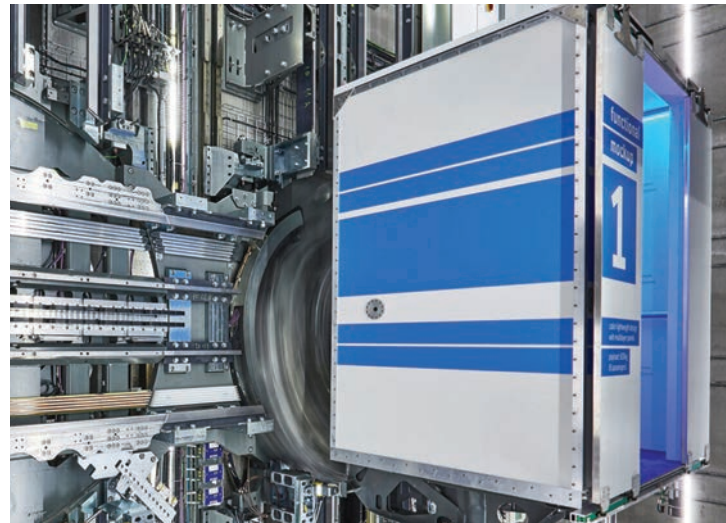

MULTI: our award-winning multidirectional elevator

At thyssenkrupp Elevator, our aim is to make cities the best ever places to live: to move people safely, comfortably and efficiently, today and tomorrow.

We do this by intelligently applying existing technologies and developing next-generation solutions – working closely with you to advance an industry that moves more than 1 billion people per day, worldwide.



MAX: real-time predictive maintenance

# Content

## 02 Choose evolution.

- 04 You’ve got options and flexibility.
- 06 We designed solutions for everyone.

## 08 This elevator is designed for you.

- 10 Features and components

## 12 Simple yet sophisticated.

- 13 Steel shell cabs
- 14 Applied panel cabs
- 15 Finishes
- 16 Cab accessory options
- 17 Fixtures
- 18 Door configurations
- 19 Entrance options

## 20 Planning

- 21 evolution 100 – passenger elevators
- 22 evolution 200 – passenger elevators
- 23 evolution 200 – service elevators
- 24 Technical specifications
- 26 Technical comparisons
- 30 MAX
- 31 AGILE

## 32 About thyssenkrupp

- 32 Our core principles
- 33 thyssenkrupp Elevator at a glance

# Choose evolution.

## Don't buy more than you need.

You know the routine. You need an elevator for your low- to mid-rise building. But it seems like there are always limitations, compromises or added costs from unwanted features.

These could be speed and capacity limitations, or complex workarounds leading to additional construction, longer schedules and frustration.

With evolution, you'll choose a traction machine room-less (MRL) model based on travel, performance, features and cab options.

We help make your choice easy.



### evolution 100

This value-driven low-rise elevator includes all the essentials.



**Travel**  
Up to 100'-0"



**Max stops**  
11



**Speed**  
200 fpm



**Capacity**  
2100 – 3500 lbs

### evolution 200

Our low- to mid-rise elevator travels farther, faster and has greater cab weight allowance.



**Travel**  
Up to 350'-0"



**Max stops**  
35



**Speed**  
200 – 600 fpm



**Capacity**  
2100 – 5000 lbs

You've got options  
and flexibility.

We've designed an MRL elevator for up to 35 stops that's not only competitive, it's better. Or if you prefer a model that covers buildings up to 11 stops, designed to give you what need – you're covered.

**You don't have to sacrifice size for speed.**  
You can have a 5000-pound capacity elevator and still go 600 feet per minute.

**You get an extra safe elevator without paying extra.**  
Our auto-rescue feature, which prevents passengers from being trapped during a power outage, comes standard.

**You get a controller that fits into an 8½-inch door jamb.**  
There's no need for a control closet, which means one less thing to build, unless your jurisdiction requires a machine room.

**You don't have to waste space.**  
Using belts means our equipment uses a small hoisting machine and therefore requires less space.

**You get a super quiet ride.**  
Our design makes it the industry's quietest, inside and out.

**You get a hassle-free installation.**  
No crane needed and everything fits into the hoistway.

**You can gain LEED credits.**  
Material and Resources credits, that is. We have material transparency certifications, declarations plus a regenerative drive that saves energy.



→ The controller is located in the door jamb at the top landing unless your local jurisdiction requires a control closet.



We designed solutions  
for everyone.

## Hey architects...

### Stop stressing over elevator space. We've got you covered.

When we say machine room-less, we mean it. Literally everything fits into the hoistway.

- It has belts, so major components like the machine and sheaves take up less space. You've got more room to design that masterpiece.
- Our elevator is supported from the guide rails — so no more overhead steel or beam pockets. Scratch that off your list.
- The controller is built right into the door jamb. So don't worry about building that controller closet or machine room.

Your lobby design doesn't have to stop at the elevator door.

- evolution 200 has lots of design choices for your cabs.
- Each pre-engineered cab design meets ASME A17.1 code.
- If those don't work, our 200 model lets you choose custom finishes, even heavy ones. Design with granite, marble, glass, barn wood — you name it.
- If you just want a basic, functional and reliable elevator, you may find the evolution 100 stainless steel cabin is the right fit.

## Hey building owners...

### Just because it's for low- to mid-rise buildings does not mean you can't get some high-quality features.

This elevator uses belts, not ropes. It's quiet and doesn't have jerky stops and starts.

- Belts are better. They weigh less than steel ropes, so the major components don't have to move as much weight, making them smaller and lighter.
- Shhh... this elevator car is super quiet, just 50 decibels — like a conversation at home after the kids are in bed.
- It's all about suspension and a finely-tuned electronic drive that gives you a smooth, smooth ride.

You really get more for your money. These advantages are standard in both evolution 100 and 200.

- We've got the power. Our auto-rescue feature means tenants won't get stuck between floors in case of power failure.
- Regenerative drive captures unused energy produced by the elevator and feeds it back in your building grid. We'll throw that in, too.
- MAX, our predictive maintenance solution, can lower your elevator downtime by up to 50 percent. Tenants will be thankful.

## Hey contractors...

### You don't need to dedicate so much time to getting your elevators installed. And since time is money, you can put your checkbook away.

evolution has a simple design for a simple installation. So go ahead and accelerate your schedule.

- Everything you need arrives at the job site in a single shipment, crates sequentially ordered. Even the electrical disconnects. How easy is that?
- It's an MRL. It truly is. All the components fit in the hoistway.

- The controller is in the door jamb at the top landing.
- It's designed so you can install the roof early. We won't need to use your crane.
- You don't need remote runs of wires from the elevator machine to the controller.
- The elevator supports itself. No need for overhead support steel.

# This elevator is designed for you.

Count on safety, reliability, energy efficiency and strong performance.



**1 Machines**  
 Our machines transport elevators up to 600 feet per minute with evolution 200, and 200 feet per minute with evolution 100. There's no machine room, so you have more leasable building space.

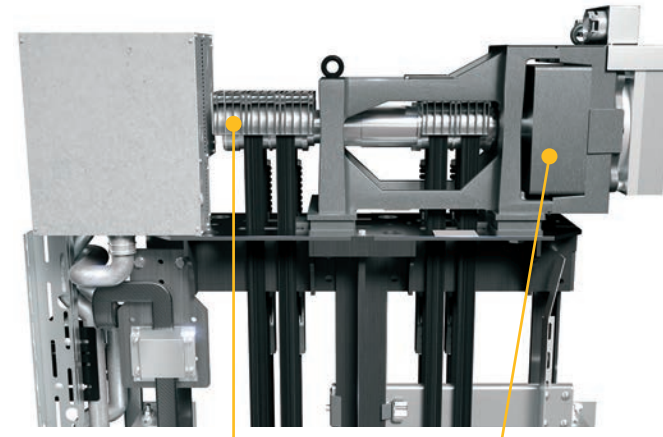

### Sheaves

The smaller sheaves in evolution have a tighter turning radius, allowing for a compact motor that takes up less overhead space.

### Permanent magnet gearless system

Improves ride quality while increasing energy efficiency.

**2 Rail-supported**  
 evolution is supported by its rails rather than your building. That means your installation requires less coordination between trades.

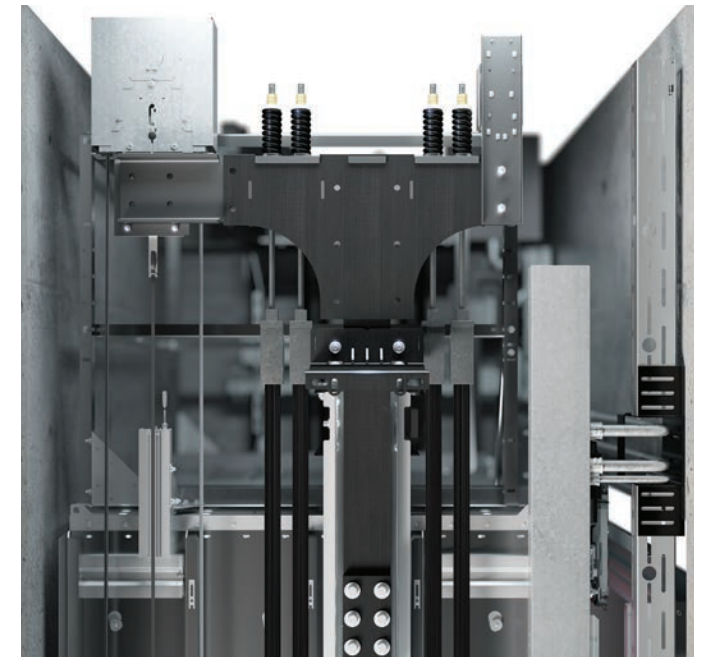

**3 Underslung design**  
 Helps evolution offer a smaller hoistway and reduced overhead space.



**4 Belts**  
 Belts have a longer life span than ropes. They also provide a quieter and smoother ride. Belts consist of twelve internal steel cords encased in FT1 rated polyurethane material, making the suspension means lighter than steel cables.



# Features and components that enhance performance, reliability, energy efficiency and safety.

## Controller

Fits into a tiny 8½-inch door jamb and is fully digital. This saves space and helps reduce elevator noise.

## Regenerative drive

Captures unused energy generated by the elevator and feeds it back into your building grid. It's more compact, faster to install, easier to maintain and replaces motor and brake contactors with SIL3 solid-state devices for a quieter and more reliable drive.

## Auto-rescue

In a power outage, passengers are automatically transported to the next available floor and doors open so they can get out.

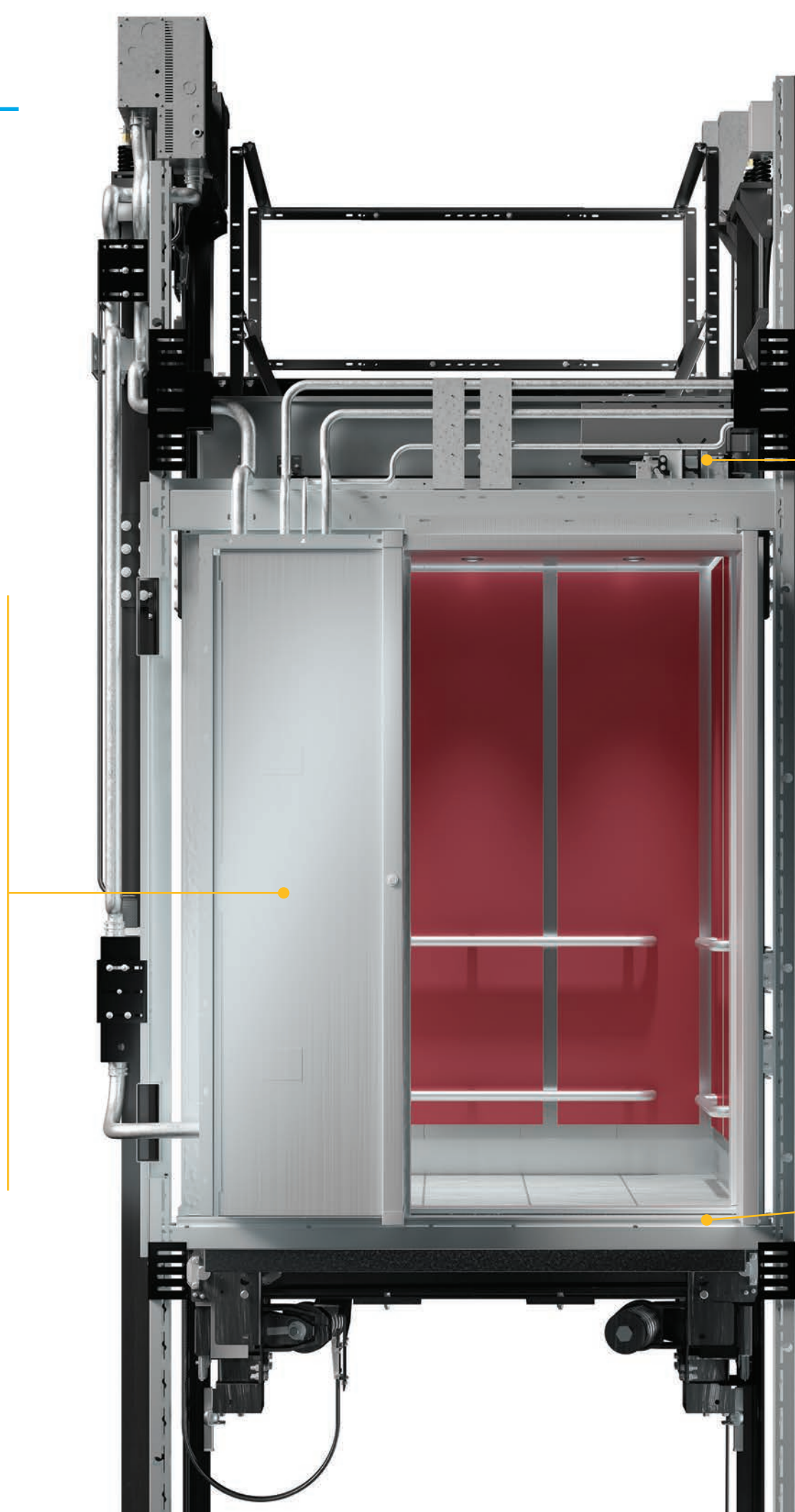

## Universal door operator

Malfunctioning doors are the leading cause of elevator service calls. This new technology provides door reliability as well as quick and smooth door operation.



Pictured: Universal door operator for evolution 200



## Absolute positioning system

Precisely measures your elevator's speed and positioning. This promotes accurate floor stopping, so floors are level and passengers are safe.

Simple yet sophisticated.

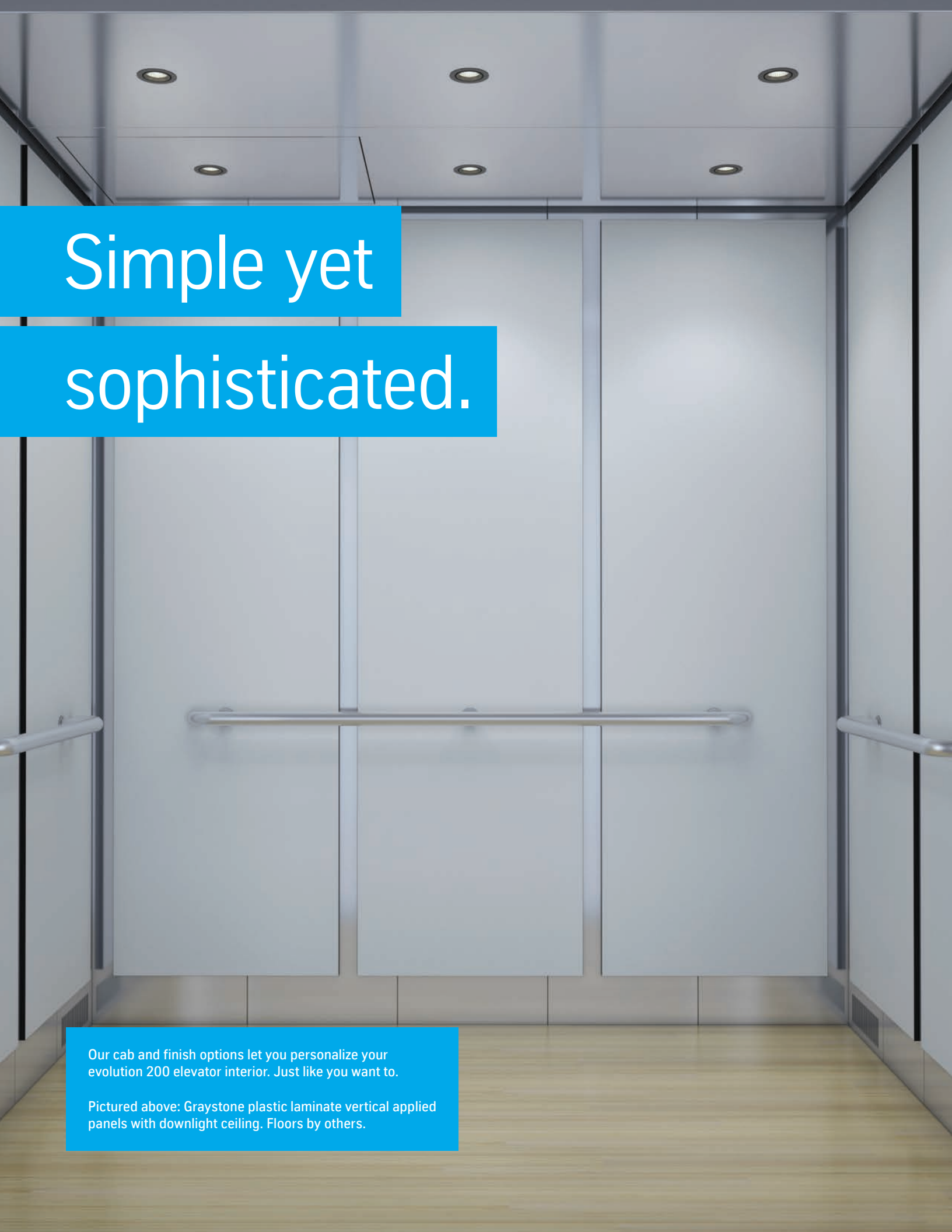

Our cab and finish options let you personalize your evolution 200 elevator interior. Just like you want to.

Pictured above: Graystone plastic laminate vertical applied panels with downlight ceiling. Floors by others.

## Steel shell

Standard cab

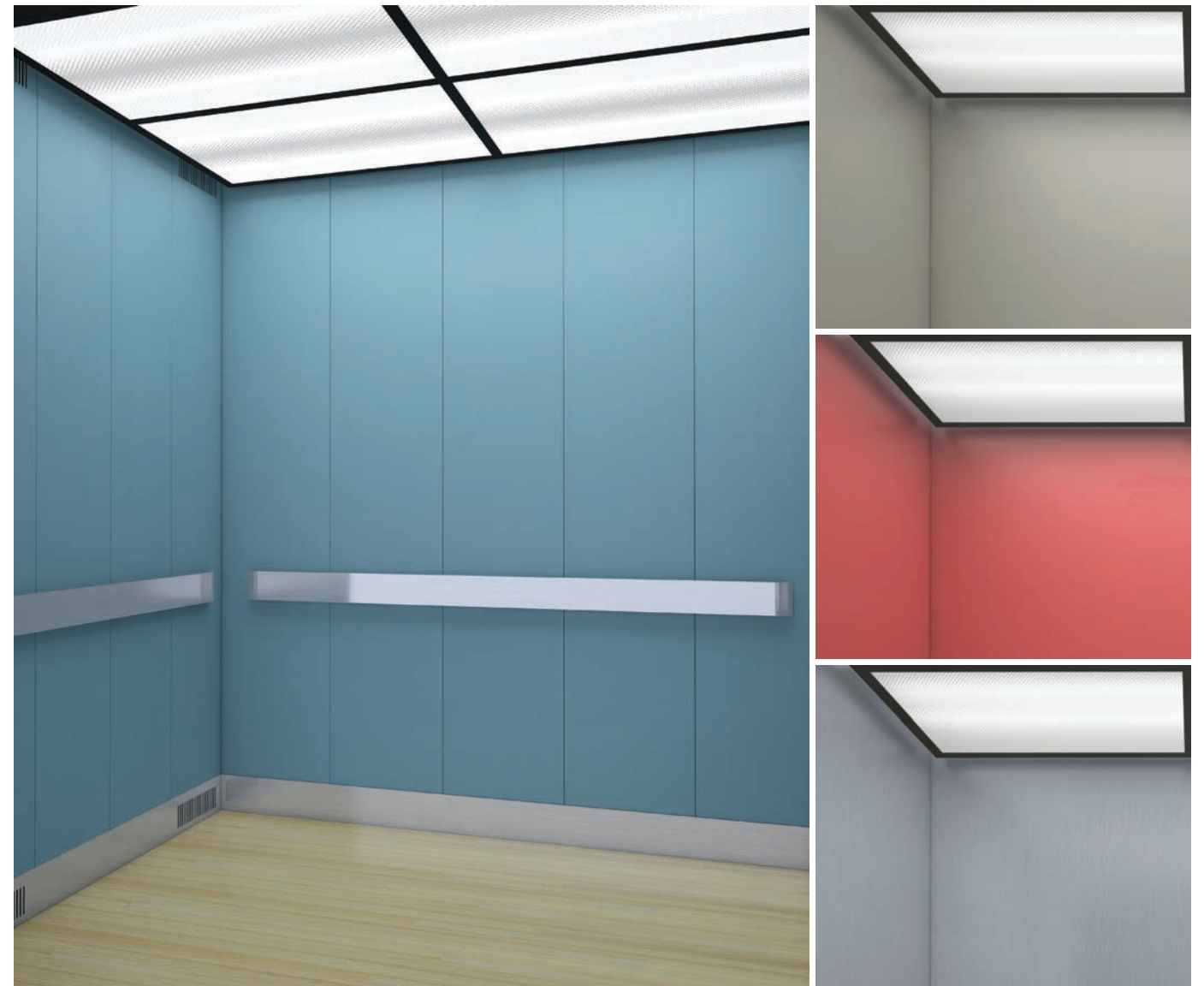

### Steel shell wall design

Clean and modern flat cab interior designs convey quality. Our durable formed steel shell cab is available in a variety of powder coat options in evolution 200, or can be upgraded to stainless steel. In evolution 100, brushed stainless steel is the only available cabin finish (powder coat options are not available).



# Applied panel

Upgraded cab

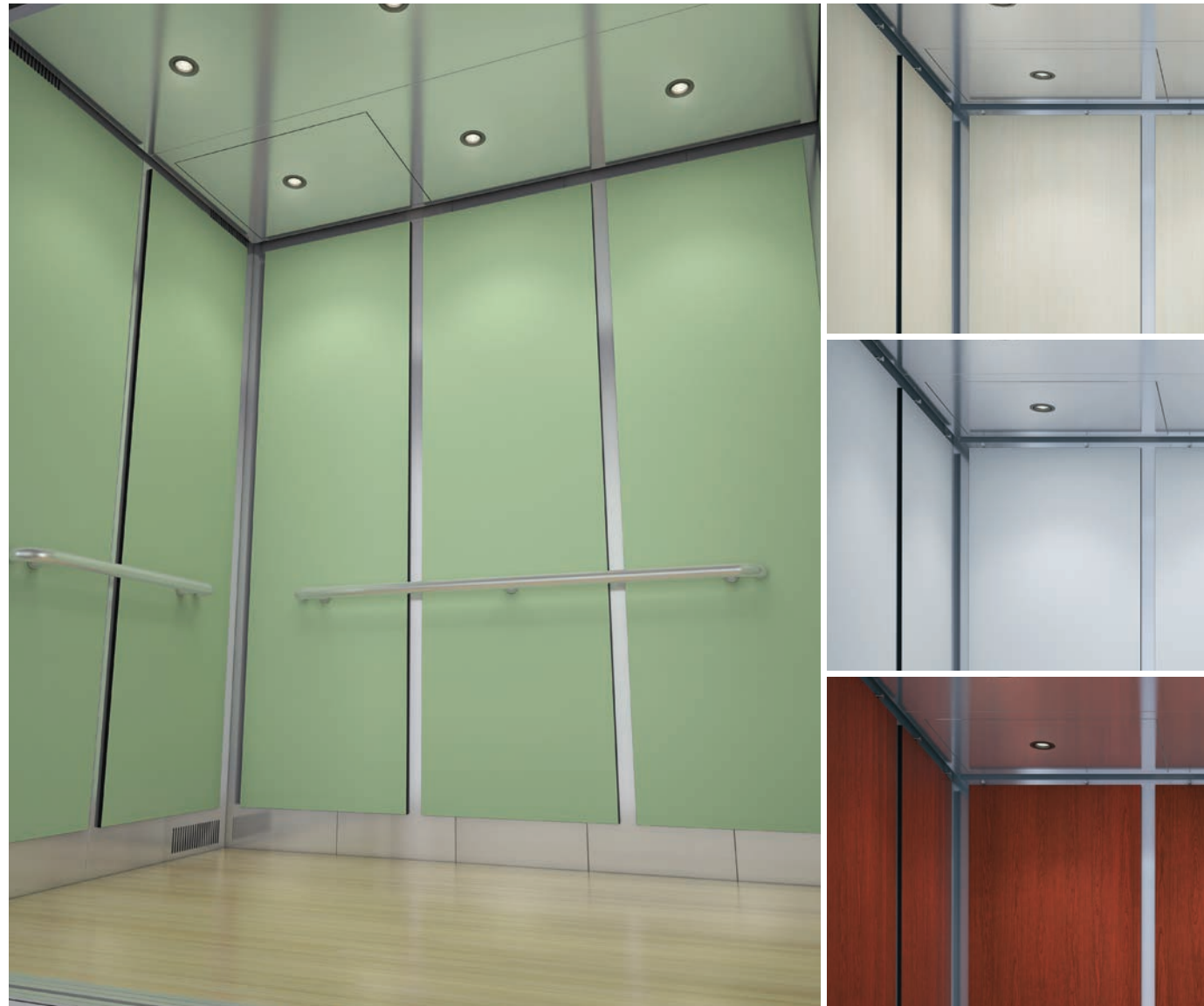

## Steel shell wall with removable panel design

Mix beauty and practicality with this decorative and durable cab. The panel design is constructed with a high-quality steel shell and vertical raised panels made with a core of urea formaldehyde-free wood. Not available with evolution 100.

# Finishes

## Plastic laminates <sup>1</sup>

### Woods

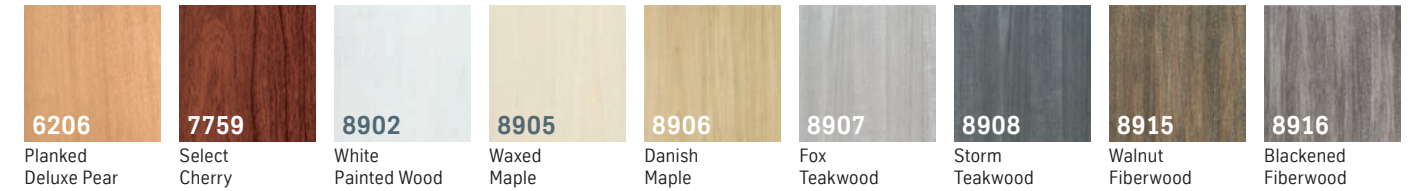

### Solids

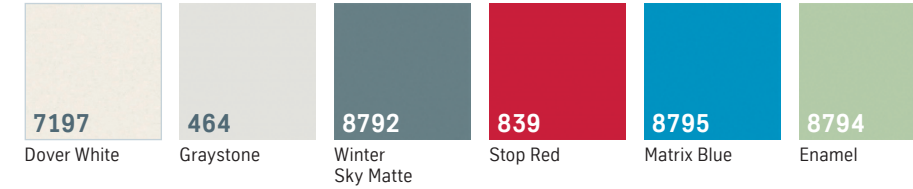

### Patterns

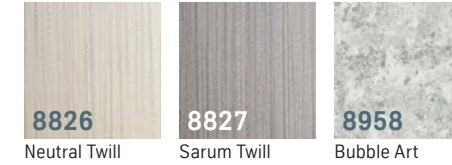

 Colors may vary. We recommend examining a large color selector sheet before making a selection.

## Powder coats <sup>1</sup>



## Metals



<sup>1</sup> Plastic laminates or powder coated wall finishes are not available for evolution 100 cabin walls, but select colors are available for entrances and hall doors.

<sup>2</sup> evolution 100 powder coat option for entrances and hall doors.

<sup>3</sup> Limited application. Contact your local representative for details.

# Cab accessory options

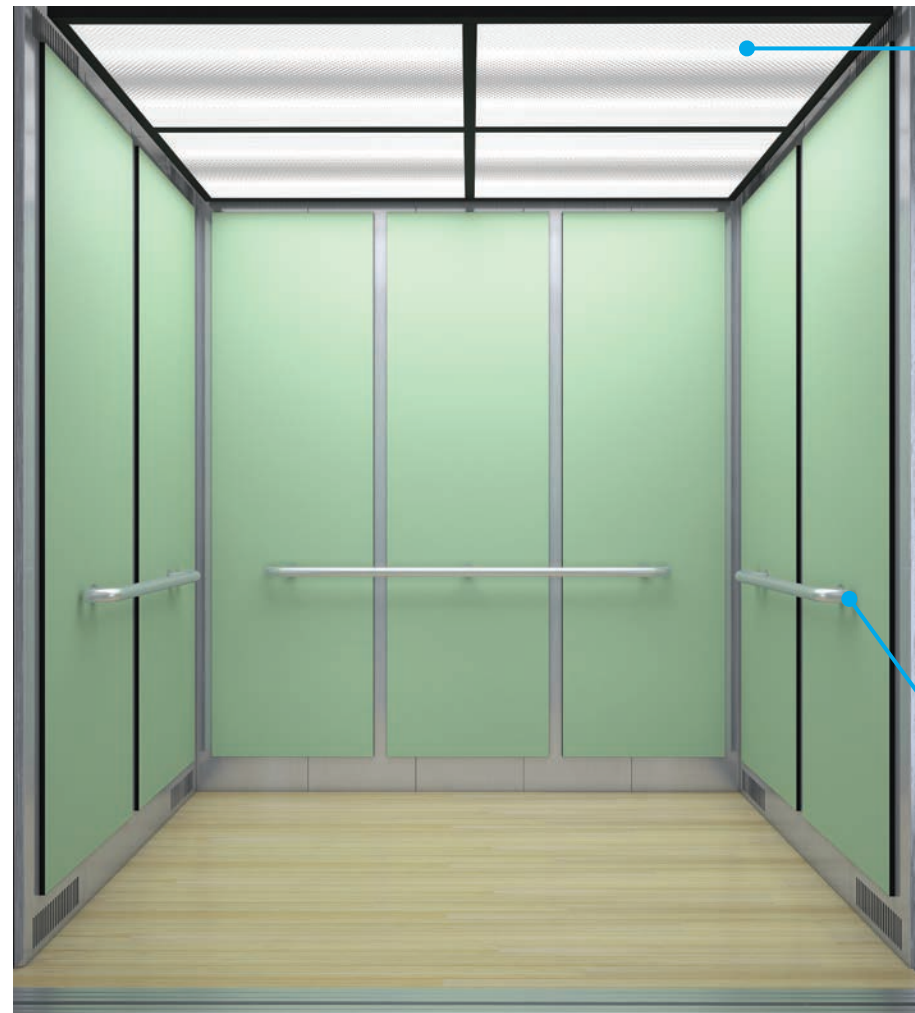

Ceilings



**Suspended**

White translucent diffusers for LED lighting are available with ceiling frames in a powder coat<sup>2</sup> or stainless steel finish.<sup>1</sup>



**Downlight**

Metal pan downlight ceiling features LED lighting with six or nine lights (based on cab size.) Lights are mounted in your choice of powder coat<sup>1</sup> or stainless steel ceiling panels.



Handrails



**Cylindrical**

1½" cylindrical handrail is a continuous metal form with ends turned toward the wall. Comes in stainless steel finish.



**Flat bar<sup>1</sup>**

Metal bar handrail is available in ¼" thickness and 2", 4" or 6" widths. Comes in stainless steel finish.

**Sills**

Our cab sill finishes allow you to match your sills to any other design component inside the cab.

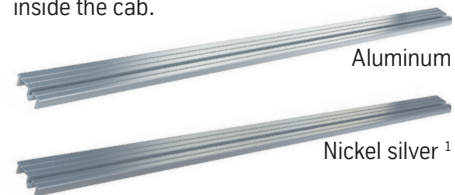

**Braille plates**

- Option 1: Resin braille plate
- Option 2: Surface mount cast braille plate
- Option 3: Flush (inlaid) mount cast braille plate<sup>1</sup>

Illustrations vary based on configurations.

<sup>1</sup> Not available on evolution 100.

<sup>2</sup> Ceiling frame is only available in black powder coat finish for evolution 100.

# Fixtures

**Traditional fixtures**

**Product details**

- Faceplates in brushed or polished stainless steel\*
- Position indicator displays car location with matrix of red LED-illuminated dots (evolution 200) or blue LED-illuminated dots (evolution 100)

**Vandal-resistant fixtures\***

**Product details**

- Faceplates in brushed or polished stainless steel\*
- Extra level of protection in challenging environments
- Pry-resistant hall jamb symbols and buttons are mounted flush with the door frame

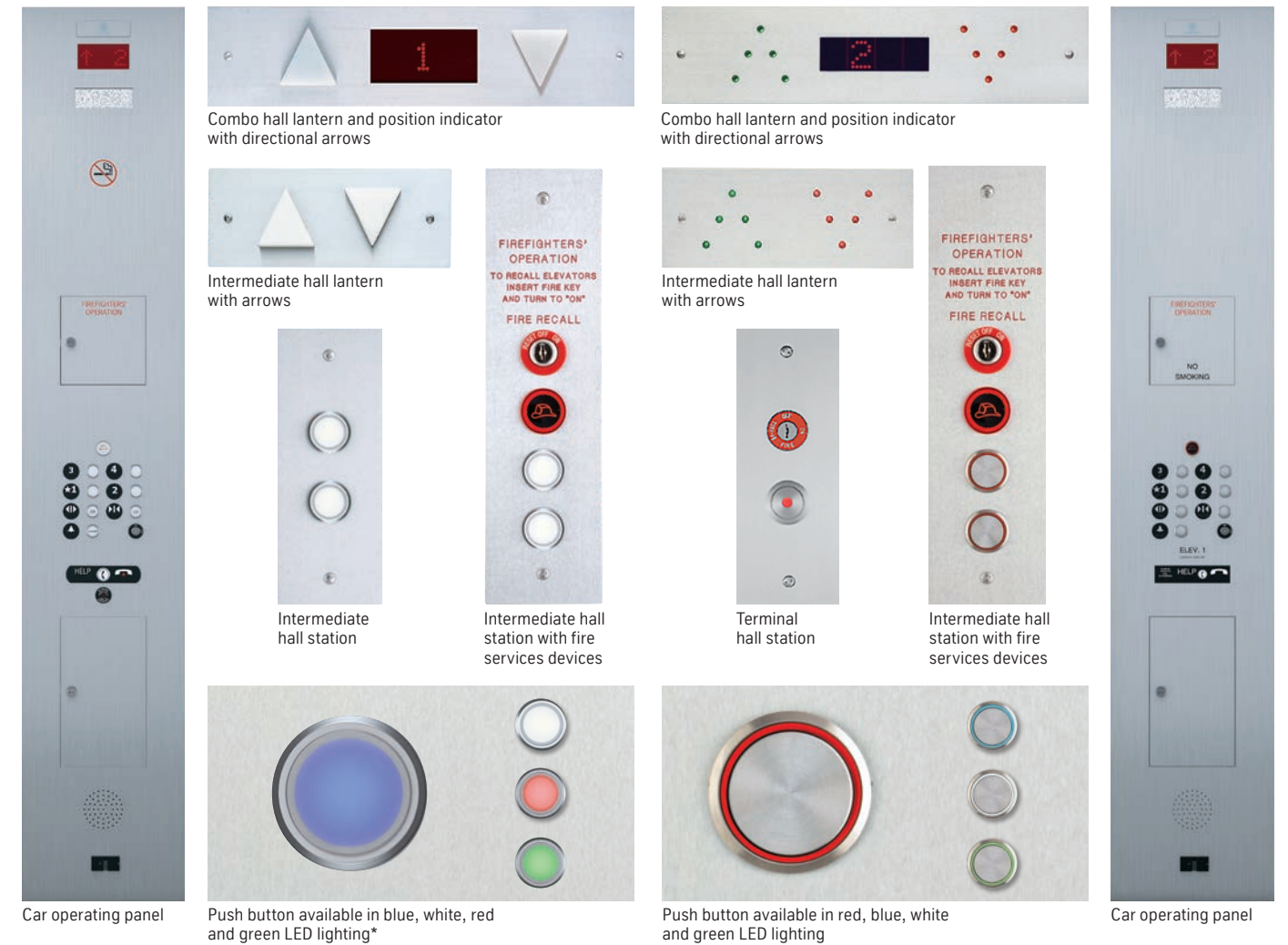

Car operating panel

Push button available in blue, white, red and green LED lighting\*

Push button available in red, blue, white and green LED lighting

Car operating panel

Fixtures shown above are for representation only. Your project-specific application may vary.

\* For evolution 100, the following are not available: Vandal resistant fixtures; polished stainless steel finishes on car or hall fixtures; red, green or blue push button illumination.

# Door configurations

Door orientation options offer a range of benefits to accommodate different project needs.

### One-speed

The most economical door offering, available with either right- or left-hand opening. (right-hand shown)

### Two-speed\*

Provides a wider opening without compromising door cycling time. Two doors move in the same direction, one sliding faster than the other. Available with either right- or left-hand opening. (right-hand shown)

### Center opening

Best for high-traffic buildings. Permits the quickest entry and exit, improving elevator service while giving an attractive, symmetrical appearance.

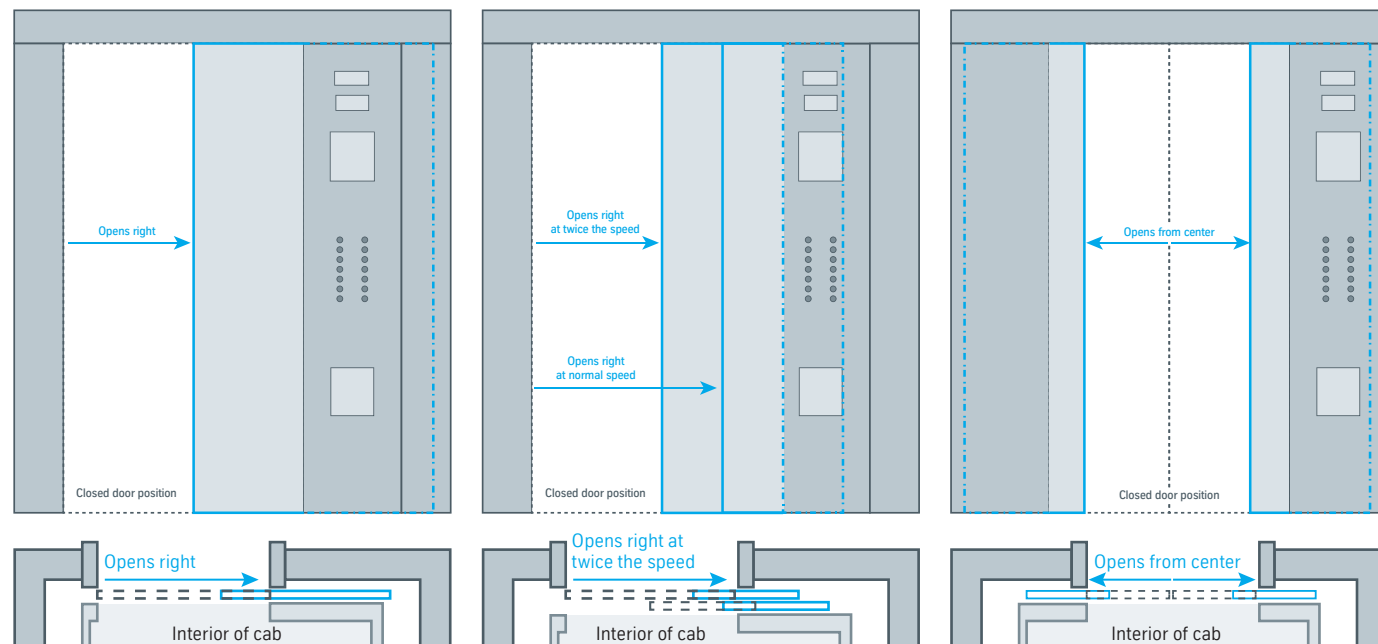

## Front returns



### Wrap-around returns

This return features a hinged car operating panel and separate filler panel. Comes standard.

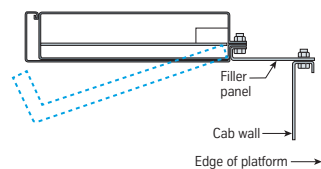

### Column returns\*\*

This return features a hinged car operating panel secured to the filler panel and aligned vertically with the column.

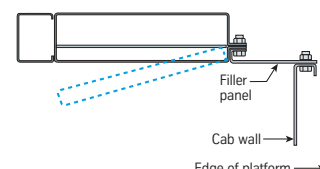

\* Not available on evolution 100.  
 \*\* Column returns only available on 4500 - 5000 lbs with a 4'-6" door, therefore not available on evolution 100..

Front returns include the car station, return panel, signal fixtures and head jamb. Images above represent return types in brushed stainless steel.

# Entrance options

The entrance frame and door are supplied by thyssenkrupp Elevator. You'll choose from powder coats or metal finishes.

## Hoistway and door entrance finishes

Typically, the entrance frame would match the door selection, but nothing says you have to. Choose from any powder coat color or metal finish.

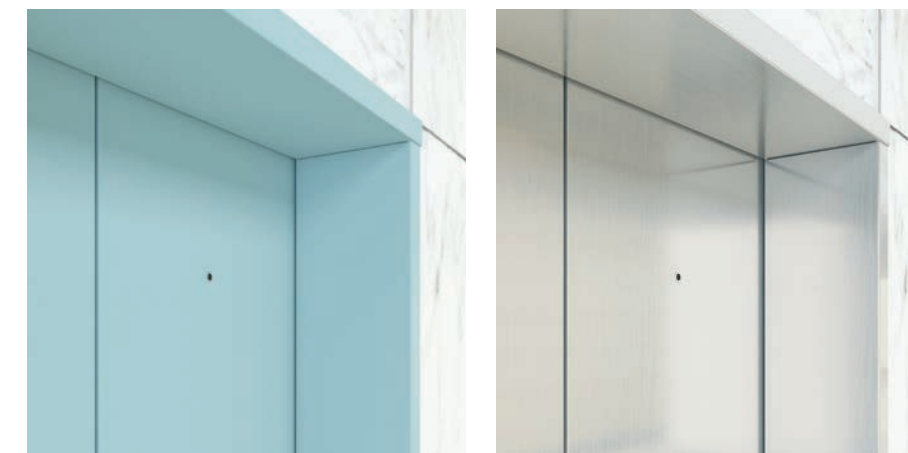

See page 15 for evolution 100 limited color options

### Powder coat finish

T-style entrance frame in Blue Patina powder coat. evolution 100 has limited color options.

### Metal finish

T-style entrance frame in Brushed Stainless Steel.





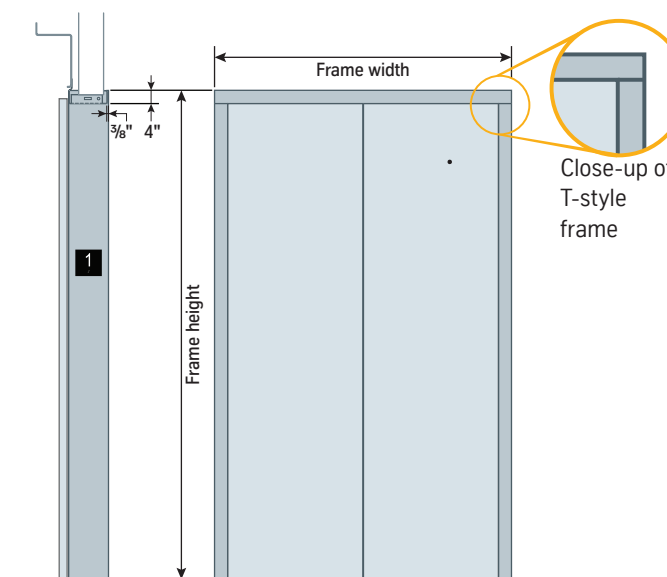



## Hoistway entrance frame

Face of frame is a minimum of four inches. Decreases to three inches on controller landing.











# Planning

## evolution 100 numbers at a glance

-  **Travel**  
100'-0"
-  **Speed**  
200 fpm
-  **Technology**  
Gearless traction
-  **Capacity**  
2100 – 3500 lbs
-  **Type**  
Self supported
-  **Fit**  
Machine room-less
-  **Max stops**  
11
-  **Max openings**  
11 (front only)  
22 (front and rear)

## evolution 200 numbers at a glance

-  **Travel**  
350'-0"
-  **Speed**  
200 – 600 fpm
-  **Technology**  
Gearless traction
-  **Capacity**  
2100 – 5000 lbs
-  **Type**  
Self supported
-  **Fit**  
Machine room-less
-  **Max stops**  
35
-  **Max openings**  
35 (front only)  
70 (front and rear)



➔ You've got options and simplicity. Planning is easy.

## evolution 100 Passenger elevators

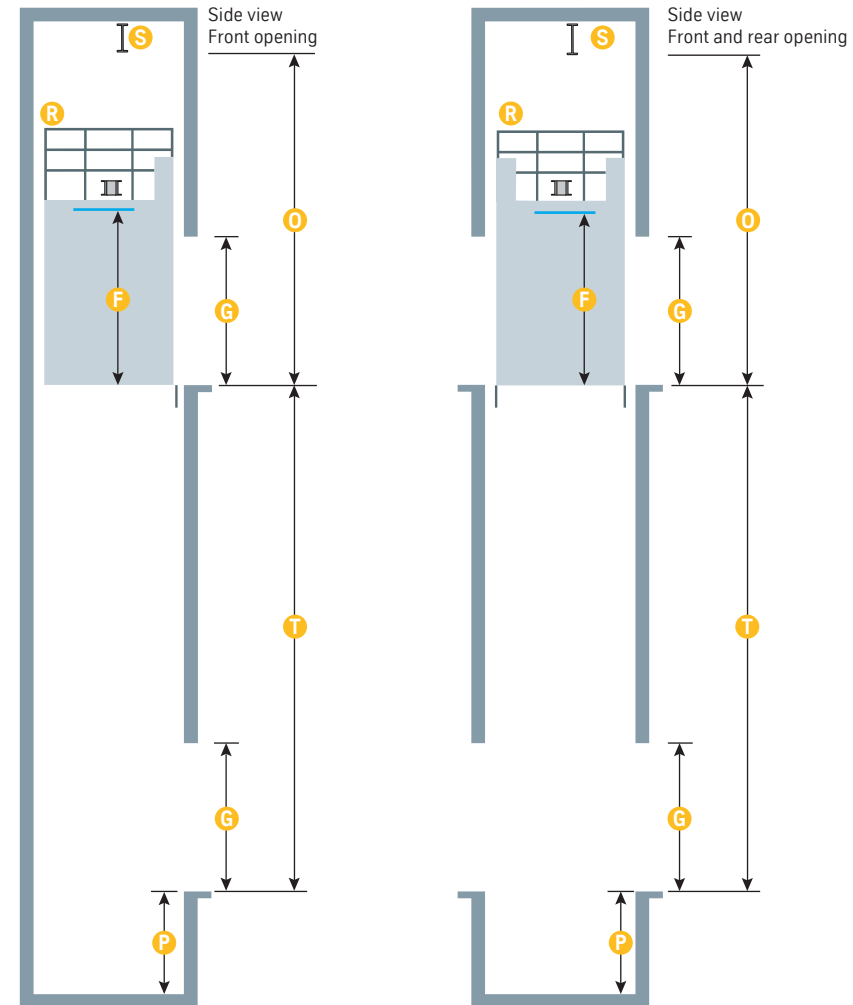

- A** Hoistway width
- B** Hoistway depth
- C** Inside clear width
- D** Inside clear depth
- E** Door clear width
- F** Inside clear height
- G** Door clear height
- I** Minimum overhead
- O** Minimum pit depth
- P** Car top railing
- R** Safety beam
- S** Travel
- T** Travel

### One-speed center opening doors

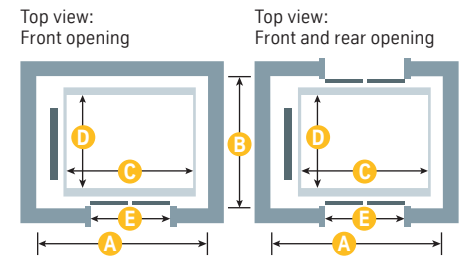

### One-speed side opening doors

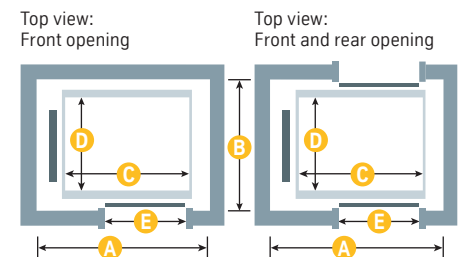

### evolution 100 – passenger elevators

Capacity (lbs)	Hoistway A x B	Front/rear	Inside clear <sup>8</sup> C x D	Door type	Door width E
2100 <sup>3, 13</sup>	7'-6" x 5'-9"	F	5'-9" x 4'-3 <sup>7</sup> / <sub>8</sub> "	One-speed	3'-0"
2500	8'-6" x 5'-9"	F	6'-9" x 4'-3 <sup>7</sup> / <sub>8</sub> "	One-speed	3'-6"
2500 <sup>5, 25</sup>	8'-6" x 6'-8 <sup>3</sup> / <sub>8</sub> "	F/R	6'-9" x 4'-3 <sup>7</sup> / <sub>8</sub> "	One-speed	3'-6"
3000 <sup>5</sup>	8'-6" x 6'-3"	F	6'-9" x 4'-9 <sup>1</sup> / <sub>2</sub> "	One-speed	3'-6"
3000 <sup>5, 25</sup>	8'-6" x 7'-2"	F/R	6'-9" x 4'-9 <sup>1</sup> / <sub>2</sub> "	One-speed	3'-6"
3500 <sup>5</sup>	8'-6" x 6'-11"	F	6'-9" x 5'-5 <sup>1</sup> / <sub>2</sub> "	One-speed	3'-6"
3500 <sup>5, 25</sup>	8'-6" x 7'-10"	F/R	6'-9" x 5'-5 <sup>1</sup> / <sub>2</sub> "	One-speed	3'-6"

- F** Inside clear height: 7'-4"<sup>1, 2</sup>
- G** Door clear height: 7'-0"
- S** 8" safety beam (2" clear above) required capable of holding 7500 lbs<sup>7</sup>
- O** Minimum overhead: 12'-8"<sup>6, 7</sup>
- P** Pit depth: 5'-0"<sup>9</sup>

All dimensions are based on a standard single hoistway in non-seismic zones. No oversized hoistway width is allowed.

Contact your local representative for various code or jurisdictional exceptions. Also contact them if same hand door configurations or other alterations are required.

See endnotes on page 29.

## evolution 200 Passenger elevators

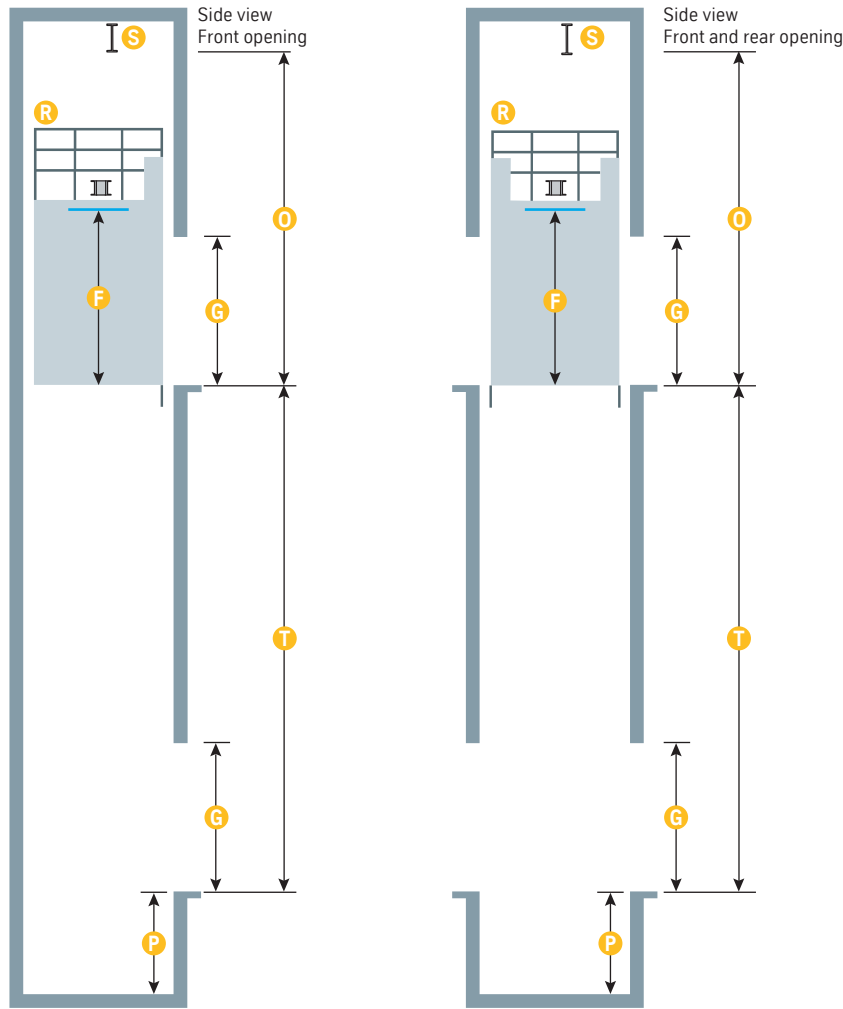

- A** Hoistway width
- B** Hoistway depth
- C** Inside clear width
- D** Inside clear depth
- E** Door clear width
- F** Inside clear height
- G** Door clear height
- O** Minimum overhead
- P** Minimum pit depth
- R** Car top railing
- S** Safety beam
- T** Travel

### One-speed center opening doors

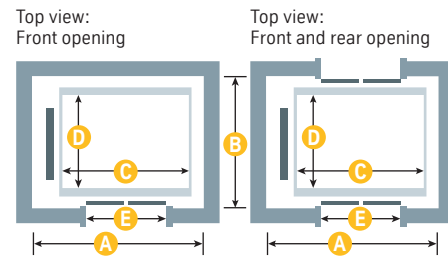

### One-speed side opening doors

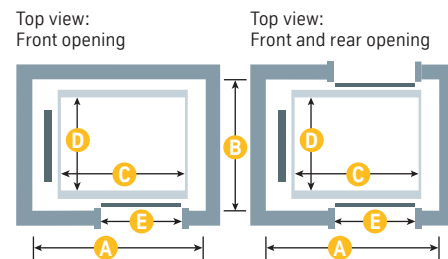

- F** Inside clear height: 7'-4" <sup>1, 2</sup>
- G** Door clear height: 7'-0" <sup>10</sup>
- S** 8" safety beam (2" clear above) required capable of holding 7500 lbs <sup>7</sup>
- O** Minimum overhead: <sup>6, 7</sup>  
 200 fpm: 12'-8"    500 fpm: 13'-11"  
 350 fpm: 13'-4"    600 fpm: 15'-0"
- P** Minimum pit depth: <sup>9, 12</sup>  
 200 fpm: 5'-0"    500 fpm: 6'-6"  
 350 fpm: 5'-6"    600 fpm: 7'-2"

All dimensions are based on a standard single hoistway in non-seismic zones.

Contact your local representative for various code or jurisdictional exceptions. Also contact them if same hand door configurations or other alterations are required.

See endnotes on page 29.

### evolution 200 – passenger elevators

Capacity (lbs)	Hoistway <sup>4</sup> A x B	Front/rear	Inside clear <sup>8</sup> C x D	Door type	Door width E
2100 <sup>3, 13</sup>	7'-6" x 5'-9"	F	5'-8" x 4'-3 <sup>3</sup> / <sub>8</sub> "	One-speed	3'-0"
2500	8'-6" x 5'-9"	F	6'-8" x 4'-3 <sup>3</sup> / <sub>8</sub> "	One-speed	3'-6"
2500 <sup>5, 25</sup>	8'-6" x 6'-8 <sup>3</sup> / <sub>8</sub> "	F/R	6'-8" x 4'-3 <sup>3</sup> / <sub>8</sub> "	One-speed	3'-6"
3000 <sup>5</sup>	8'-6" x 6'-3"	F	6'-8" x 4'-9"	One-speed	3'-6"
3000 <sup>5, 25</sup>	8'-6" x 7'-2"	F/R	6'-8" x 4'-9 <sup>1</sup> / <sub>2</sub> "	One-speed	3'-6"
3500 <sup>5</sup>	8'-6" x 6'-11"	F	6'-8" x 5'-5"	One-speed	3'-6"
3500 <sup>5, 25</sup>	8'-6" x 7'-10"	F/R	6'-8" x 5'-5 <sup>1</sup> / <sub>2</sub> "	One-speed	3'-6"
4000 <sup>5</sup>	9'-6" x 6'-11"	F	7'-8" x 5'-5"	One-speed	3'-6"/4'-0"
4000 <sup>5</sup>	9'-6" x 7'-10"	F/R	7'-8" x 5'-5 <sup>1</sup> / <sub>2</sub> "	One-speed	3'-6"/4'-0"

## evolution 200 Service elevators

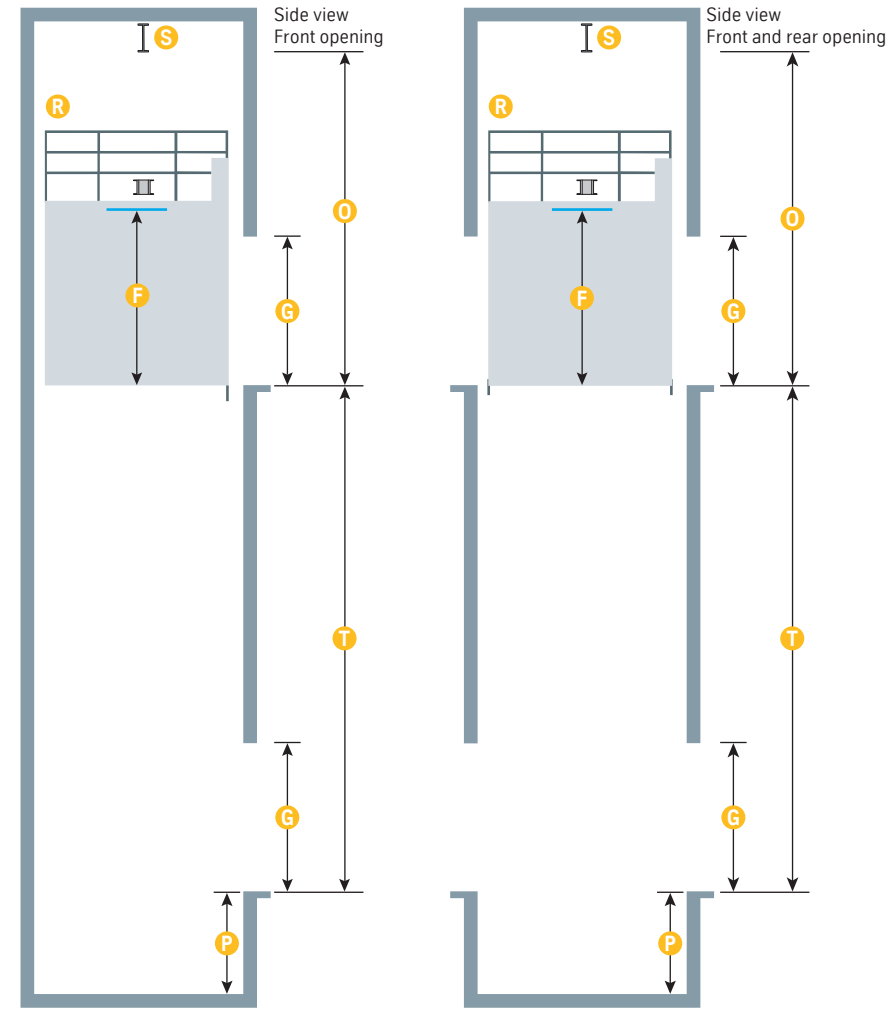

- A** Hoistway width
- B** Hoistway depth
- C** Inside clear width
- D** Inside clear depth
- E** Door clear width
- F** Inside clear height
- G** Door clear height
- O** Minimum overhead
- P** Minimum pit depth
- R** Car top railing
- S** Safety beam
- T** Travel

### Two-speed side opening doors

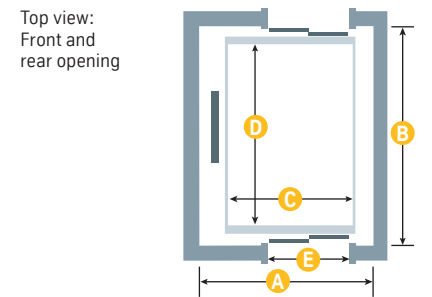
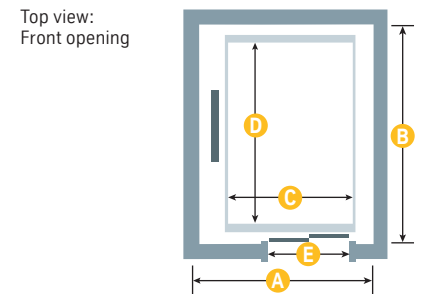

- F** Inside clear height: 7'-4" <sup>1, 2</sup>
- G** Door clear height: 7'-0" <sup>10</sup>
- S** 8" safety beam (2" clear above) required capable of holding 7500 lbs <sup>7</sup>
- O** Minimum overhead: <sup>6, 7</sup>  
 200 fpm: 12'-8"    500 fpm: 13'-11"  
 350 fpm: 13'-4"    600 fpm: 15'-0"
- P** Minimum pit depth: <sup>9</sup>  
 200 fpm: 5'-0"    500 fpm: 6'-6"  
 350 fpm: 5'-6"    600 fpm: 7'-2"

All dimensions are based on a standard single hoistway in non-seismic zones.

Contact your local representative for various code or jurisdictional exceptions. Also contact them if same hand door configurations or other alterations are required.

See endnotes on page 29.

### evolution 200 – service elevators

Capacity (lbs)	Hoistway <sup>4, 11</sup> A x B	Front/rear	Inside clear <sup>8</sup> C x D	Door type	Door width <sup>11</sup> E
4500	7'-6" x 9'-6 <sup>1</sup> / <sub>2</sub> "	F	5'-8" x 7'-9 <sup>1</sup> / <sub>2</sub> "	Two-speed	4'-0"/4'-6"
4500 <sup>25</sup>	7'-6" x 10'-8 <sup>1</sup> / <sub>2</sub> "	F/R	5'-8" x 7'-10"	Two-speed	4'-0"/4'-6"
5000	7'-6" x 10'-2"	F	5'-8" x 8'-5"	Two-speed	4'-0"/4'-6"
5000 <sup>25</sup>	7'-6" x 11'-4"	F/R	5'-8" x 8'-5 <sup>1</sup> / <sub>2</sub> "	Two-speed	4'-0"/4'-6"
5000H	7'-6" x 10'-9"	F	5'-8" x 9'-0"	Two-speed	4'-0"/4'-6"
5000H <sup>25</sup>	7'-6" x 11'-11"	F/R	5'-8" x 9'-0 <sup>1</sup> / <sub>2</sub> "	Two-speed	4'-0"/4'-6"

# Technical specifications

<b>Power characteristics</b>	Low- or high-voltage power requirement is based on machine size, car capacity and number of belts. 480 volts, 3 phase, 60 hertz (high voltage) is used on six belt systems with speed of 200 fpm or greater and 3500-pound cars or greater, but high voltage may be required on some four belt systems if the larger machine is used. With a 3500-pound car or less, using four belts with speed of 200 fpm, the lower voltage option is available.  Isolation transformer may be required on jobs with less than 480 VAC, 3 phase or if building supply is 575 VAC. Transformer must be located within 125 feet of controller. Transformer installed by thyssenkrupp Elevator but wiring installed by others.
<b>Brakes</b>	Dual braking system (main and emergency)
<b>Solid state brake controls</b>	Contactless components for emergency and normal brakes as well as motor that reduces noise
<b>Number of belts</b>	Four or six, based on car capacity, car weight requirements and travel.
<b>Suspension means</b>	Flat belt: 42.5 mm belt width and 3.1 mm thickness; 12 internal steel cords encased in FT1 rated PU material
<b>Belt monitoring</b>	Monitored by residual life span, traction loss detection device, belt member loss and a trip count
<b>Machines</b>	Permanent magnet gearless machine
<b>Absolute position system</b>	Elgo, sensor reads position data off of magnetic tape
<b>Drive</b>	Fully regenerative digital drive with automatic rescue included
<b>Controller</b>	TAC32T (in the wall or in optional control space if required by local jurisdictions, building constraints, and job-specific performance)
<b>Door operator</b>	Universal door operator
<b>Car guides</b>	Slide guides standard at 200 fpm; Roller guides standard at 350 – 600 fpm
<b>Counterweight guides</b>	Slide guides standard at 200 – 600 fpm
<b>Counterweight</b>	Side only
<b>Governor</b>	Wittur, remote resetting governor
<b>Finished floor height</b>	3/4" or 3/8" standard

**A quiet ride**  
This elevator is very quiet. It emits fewer decibels than a normal conversation at home.\*

\*Source: Decibel comparison values from E•A•RCAL Laboratory, 3M Occupational Health and Environmental Safety Division

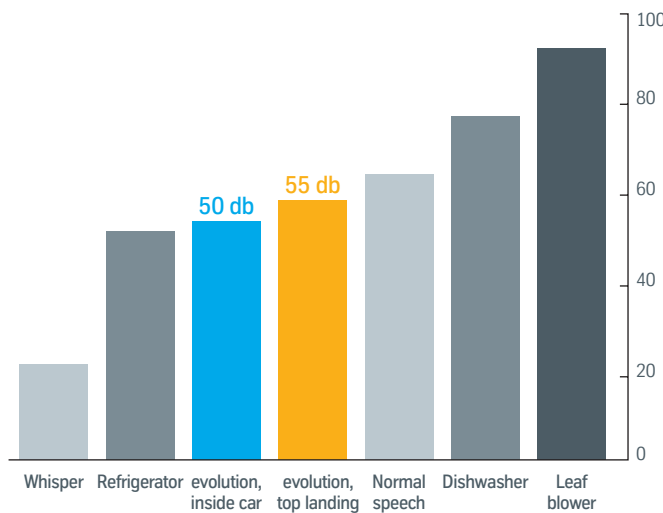

## evolution hoistway efficiency

Everything fits into the hoistway, giving you more leasable building space.

Reduced hoistway width, depth and height are due to the compact machine with small components and underslung design. This results in a smaller building footprint.

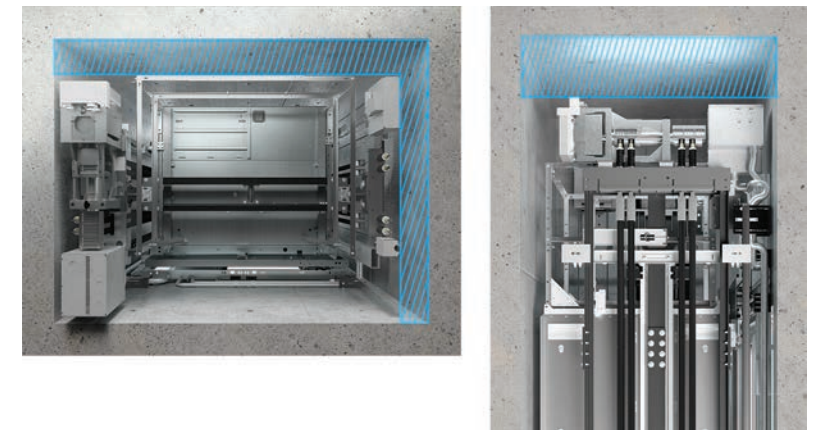

## evolution controller closets

The features of your evolution system determine the controller closet you'll need.

Controller closets includes room for controller, disconnect and resistor boxes. The most desirable controller closet location is on the top floor served, adjacent to the elevator hoistway.

At an additional cost, it may be located remotely, but the traveling cable must be no longer than 150 feet from the machine to controller.

Some jurisdictions require controller closets to be full-body entry; small spaces or closets may not be acceptable. Check with your thyssenkrupp Elevator representative.

evolution simplex <sup>23</sup>			
Size	A	B	C
Small	4'-6"	2'-0"	3'-0"
Medium	3'-10"	4'-7"	3'-0"
Large	4'-6"	5'-11"	3'-6"

evolution duplex <sup>23, 24</sup>			
Size	D	E	F
Small	5'-6"	5'-5"	3'-0"
Large	9'-2"	5'-5"	3'-0"

See endnotes on page 29.

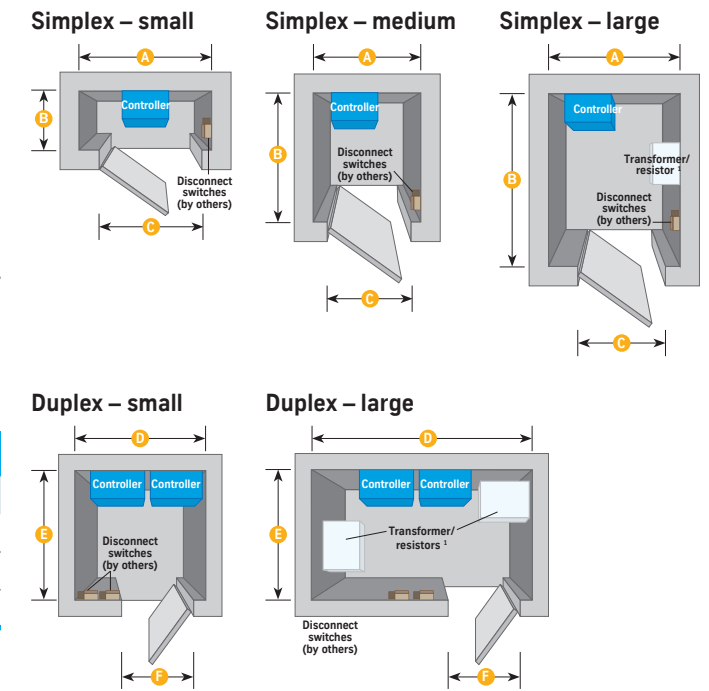

# Technical comparisons

	evolution 100	evolution 200
<b>Base options</b>		
Elevator load capacities	2100, 2500, 3000, 3500	2100, 2500, 3000, 3500, 4000, 4500, 5000, 5000H
Elevator car speed	200 fpm	200, 350, 500 and 600 fpm
Max travel	100'-0"	350'-0"
Max stops	11	35
Seismic zones	0, 1, 2, 3, 4	0, 1, 2, 3, 4
Cab weight allowances	Up to 300 lbs, depending on speed/capacity combination	Up to 1500 lbs, depending on speed/capacity combination
Cab type	TKS	TKAP, TKS
Cab height (nom.)	8'-0" only	8'-0", 9'-0", 10'-0"
Door clear height	7'-0" only	7'-0", 8'-0", 9'-0"
Front and rear openings <sup>13</sup>	+	+
<b>Door width:</b>		
3'-0"	+	+
3'-6"	+	+
4'-0"	⊗	+
4'-6"	⊗	+
Door opening type – single speed LH or RH and CO <sup>3</sup>	+	+
Maximum openings (front only   front and rear)	11   22	35   70
Max number of cars in a group	8	8
Permanent magnet gearless machine	✓ (PMB285L)	✓ (PMB285XL or PMB285L)
Car sling and platform	✓	✓
Rail-supported	✓	✓
Remote-resetting governor (Wittur, 12")	✓	✓
Jamb-mounted digital controller	+	+
Universal door operator (LD16 / LD16 Plus)	✓ (LD16 only)	✓

	evolution 100	evolution 200
<b>Base options</b>		
Absolute positioning system (ELGO)	✓	✓
Dual braking system (main and emergency)	✓	✓
Solid state brake controls <sup>14</sup>	✓	✓
Complies with IBC codes	yes	yes
Voltage (3 phase 60 hertz)	208, 240, 460, 575 (Canada only)	208, 240, 460, 575 (Canada only)
Flat belts suspension means <sup>15</sup>	✓	✓
Number of belts	4	4 or 6 (for 3500 lbs capacities or greater and exceeds 250' of travel)
Flat belts monitoring <sup>16</sup>	✓	✓
Car rails	15 lbs	15 lbs
Counterweight rails	8 lbs or 15 lbs	8 lbs or 15 lbs
Counterweight – side mounted only	✓	✓
Car guides	slide	slide or roller (used at 350-600 fpm)
Counterweight guides	slide	slide
Compensation	Not required at any speed or travel	No compensation required. Up to 100 ft travel, EXCEPT all 5000 lbs capacities & speed > 350 for 4000 and 4500 lb capacities
Pit ladders – retractable, 12" (16" also available)	✓	✓
Ladder brackets	✓	✓
Minimum pit depth – 5'	✓ (5 foot pit depth only)	✓
Car buffers – stroke determined by speed	✓	✓
Counterweight buffers – always two	✓	✓
<b>Controller location – if remote<sup>17</sup></b>		
In jamb at top landing	✓	✓
Controller closet	+	+

**Key**

✓ Comes standard    + Available    ⊗ Not available

FPM Feet per minute    LBS Pounds

See endnotes on page 29.

	evolution 100	evolution 200
<b>Fixture, entrance and other options</b>		
TAC32T slim controller	✓	✓
Regenerative drive	✓	✓
Regenerative disable	+	+
Car canopy – 14 gauge	✓	✓
Car canopy finish	White (PC) only	White (PC) only
Safety beam – provided and installed by others <sup>18</sup>	✓	✓
Hall station type – terminal or intermediate <sup>19</sup>	✓	✓
Hall fixtures	Traditional	Traditional and Vandal-resistant
<b>Lantern styles</b>	Arrow only	Arrow only
<b>Lantern illumination</b>		
Traditional, Vandal-resistant – red, blue, green, white	+	+
Braille	✓ (Limited to two characters, no flush-mount available)	✓
Fire service – mounted separate or in hall station	✓	✓
Fire service signage	✓ (No engraving)	✓
Appendix H/O signage	✓ (Separate adhesive-backed, wall-mounted only)	✓
Hall call lockouts	⊗	+
<b>Entrances</b>		
Face of frame	3" at controller landing; all others 4"	3" at controller landing; all others 2"
AGILE 12" Kiosk	⊗	+
Black anodized aluminum frame with black-edged screen	⊗	+
Polished aluminum frame with black-edged glass screen	⊗	+
Polished aluminum frame with white-edged glass screen	⊗	+

	evolution 100	evolution 200
<b>Fixture, entrance and other options</b>		
<b>Door and frame finish</b>		
Powder coat <sup>20</sup>	+	+
Brushed stainless steel #4	+	+
Polished stainless steel #8	⊗	+
Fascia	Partial or full; partial applies automatically with the code year selection of 2000 or greater	Partial or full; partial applies automatically with the code year selection of 2000 or greater
Bottom pit fascia	+	+
Keyholes	+	+
3-D door protection	+	+
Predictive maintenance solution – MAX	✓	✓
Auto-rescue <sup>21</sup>	✓	✓
<b>Fixture finish</b>		
Brushed stainless steel #4	+	+
Polished stainless steel #8	⊗	+
<b>Final limit location</b>		
Car top mount	✓	✓
Hoistway mount	+	+
<b>Controller options</b>		
Infant security	⊗	+
Sabbath	⊗	+
Inconspicuous riser	⊗	+
MKII shutdown	⊗	+
Car riding lantern	✓	✓
Hall lantern	+	+
Door hold (Door operator controls)	⊗	+
eMax (aka MAX)	+	+
Fire service	✓	✓
Hoistway access	+	+

See endnotes on page 29.

	evolution 100	evolution 200
<b>Fixture, entrance and other options</b>		
Independent service	+	+
Loadweigher controls	+	+
Position indicator	+	+
Remote governor reset	+	+
Sleep mode	+	+
User Interface tool	+	+
Hoistway enable/ Inspection operation	+	+
Isolation transformer	⊗	+
Standby power	+	+
Tenant security (3.1 only)	+	+
<b>Cab design</b>		
Protection pads	+	+
<b>Cab shell</b>		
14 gauge	⊗	+
16 gauge	+	+
<b>Shell finish</b>		
Powder coat <sup>20</sup>	⊗	+
Brushed stainless steel #4	+	+
Brushed stainless steel #4 (316 series)	⊗	+
Polished stainless steel #8	⊗	+
5WL stainless pattern	⊗	+
<b>Finished floor height</b>		
¾" floor	+	+
⅝" floor	✓	✓
<b>Cab finishes</b>		
Powder coat <sup>20</sup>	⊗	+
Brushed stainless steel #4	+	+
Polished stainless steel #8	⊗	+
Brushed stainless steel #4 (316 series)	⊗	+
Plastic laminates - for applied panels	⊗	+
Laminate color selections	⊗	Solids, patterns and woods

**Key**  
 ✓ Comes standard    + Available    ⊗ Not available

	evolution 100	evolution 200
<b>Cab design</b>		
Cab finishes by others	⊗	+
<b>Ceiling type</b>		
Basic flat	⊗	⊗
Suspended	✓ (frame finish in black only)	+
Downlight	+	+
<b>Handrail finishes</b>		
Brushed stainless steel #4	✓	+
Polished stainless steel #8	⊗	+
<b>Handrail type</b>		
1.5" cylindrical	✓	+
2" flat bar	⊗	+
4" flat bar	⊗	+
6" flat bar	⊗	+
Bumpers	⊗	+
<b>Sills</b>		
Aluminum	✓	+
Nickel silver	⊗	+
<b>Entrances</b>		
Door gauge	18 gauge	18 gauge (standard), 16 gauge
<b>Cab door and frame finish</b>		
Powder coat <sup>20</sup>	⊗	+
Brushed stainless steel #4	✓	+
Polished stainless steel #8	⊗	+
Kickplate	⊗	+
Cab base	⊗	+
Welded frames	⊗	+
Microlight	✓	✓
Cab fan – two speed	✓	✓
Car fixtures	Traditional	Traditional and Vandal-resistant
Car fixtures buttons – traditional with T2	White only	White, red, green and blue
Car fixtures buttons – traditional with vandal-resistant	⊗	White, red, green and blue

See endnotes on page 29.  
**FPM** Feet per minute    **LBS** Pounds

	evolution 100	evolution 200
<b>Cab design</b>		
<b>Car signals and COP</b>		
Car call lockout	⊗	+
Emergency light test	+	+
Door hold open	⊗	+
Braille plates	Standard (no flush-mounted)	Standard, Cast Disc Flush
Position indicator	2" dot matrix CAN only (No CE display)	1" or 2" dot matrix or CE dot matrix
Capacity plate	Standard, no engraving	Standard or engraved
Smart rescue phone <sup>22</sup>	✓	✓
Auxiliary COP	1 only	Maximum of 3 – limited by cab openings and door types
Car riding lanterns	Traditional	Traditional and Vandal-resistant
Additional car riding lanterns	⊗	+
AGILE supported	⊗	+

	evolution 100	evolution 200
<b>Cab design</b>		
Locked compartment	+	+
Fire compartment	+	+
Medical emergency key switch	+	+
Card reader override switch	+	+
Fire service	+	+
Hoistway enable	+	+
Independent service	+	+
NC special access	+	+
Card reader 4 x 4 space only	+	+
Seismic jewel	+	+
thyssenkrupp Elevator emblem	+	+
French english car station markings	+	+

**Endnotes**

Dimensional data shown is for non-seismic zones and complies with current ASME A17.1 and CSA B44 Safety Code for Elevators. Local codes may vary from the national codes. Consult your thyssenkrupp Elevator representative for details.

- <sup>1</sup> Inside clear heights of 8'-4" and 9'-4" are also available on an evolution 200 model.
- <sup>2</sup> Dimension shown is the distance between the suspended ceiling and a maximum ¾" finished floor. If ¾" finished floor, the inside clear height increases to 7'-4⅝".
- <sup>3</sup> 2100 lbs car capacity is not available with center opening doors.
- <sup>4</sup> For non-seismic installations, add 1" to hoistway width when travel exceeds 100'. For seismic Zone 2 or greater or IBC equivalent, add 2" to hoistway width if travel is less than or equal to 100'. For seismic Zone 2 or IBC equivalent, add 3" to hoistway width if travel exceeds 100'. For seismic Zone 3 or greater or IBC equivalent, add 3" to the hoistway width if travel is between 100' - 250'. For seismic Zone 3 or greater or IBC equivalent, add 6" to hoistway width if travel is greater than 250'.
- <sup>5</sup> To achieve IBC stretcher compliance, you can accommodate an 84" ambulance stretcher in car capacities of 2500, 3000, 3500, and 4000 lbs with 3'-6" side opening doors. However, this is dependent on cab and door configurations. We also offer 4500 and 5000 lbs car capacities with no configuration restrictions. Contact your thyssenkrupp Elevator representative for specific cab and door configurations.
- <sup>6</sup> For areas enforcing ASME A17.1 2010 code or greater, the minimum overhead requirement is the same for simplex/multicar/seismic/non-seismic. For areas enforcing pre-2010 ASME A17.1 code and speed is equal to 200 fpm, the minimum overhead is still the same, but if speed increases to 350 fpm or more, the minimum overhead is greater than what is shown. Contact your local representative for overhead requirements.
- <sup>7</sup> Provided and installed by others, as directed by the local office. Minimum overhead is shown to the bottom of the safety beam.
- <sup>8</sup> Inside clear cab dimensions are based on maximum ½" applied wall panel for the evolution 200 product, but dimensions for evolution 100 are based on stainless steel shell walls.
- <sup>9</sup> If occupied space below a pit is required, counterweight safeties come standard for evolution 200, but contact your local representative for full details.
- <sup>10</sup> Door clear height of 8'-0" and 9'-0" are also available for taller cabs on evolution 200 but contact your local representative for additional details.
- <sup>11</sup> For 54" (4'-6") doors, hoistway width increases to 8'-3" for non-seismic and seismic and are limited to the closet-mounted controller configuration only. For 48" (4'-0") doors, see note 4.
- <sup>12</sup> Minimum pit depth increases to 6'-6" on a 4000 lbs capacity car, going 350 fpm when it exceeds 225' of travel because it needs a compensation wheel for balancing the car.
- <sup>13</sup> Front and rear openings are not available on 2100 lbs capacity cars.
- <sup>14</sup> Contactor-less components for brakes as well as motor that reduces noise.
- <sup>15</sup> 42.5 mm belt width and 3.1 mm thickness; 12 internal steel cords encased in FT1 rated PU material.
- <sup>16</sup> Monitored by residual life span, traction loss detection device and belt member loss and a trip counter. Monitor remains a part of system indefinitely or until it is replaced or upgraded.
- <sup>17</sup> Entrance mounted controllers cannot be grouped with closet applications.
- <sup>18</sup> A minimum of 2" of clearance between the top of the 8" safety beam and underside of hoistway ceiling is required.
- <sup>19</sup> Features in hall stations are limited to a combination of 3 devices.
- <sup>20</sup> Powder coat colors from standard selection; no special paints. Not available on evolution 100 cab interiors, but limited color options available on entrances and hall doors.
- <sup>21</sup> Emergency evacuation to the next landing. (It is automatic and load dependent.)
- <sup>22</sup> 5- or 10-car supported. With jamb-mounted controllers, mounting location and provisions will have to be determined.
- <sup>23</sup> Controller closet temperature range 32°F minimum, 104°F maximum. 10-95% non-condensing relative humidity.
- <sup>24</sup> May also use two separate closets.
- <sup>25</sup> On front and rear door opening cars that are configured with same hand doors (catty-corner), additional hoistway width is required. For 2500, 3000, 3500 capacity cars with 42" (3'-6") doors and 4500, 5000 cars with 48" (4') doors, hoistway width must be increased additionally by 2". For 4500, 5000 cars with 54" (4'-6") doors, hoistway width must be increased additionally by 11".

Illustrations and images in this brochure may differ from the installed product. Consult your local representative for more information.





Give passengers more efficient experiences by adding AGILE, our performance-enhancing Destination Dispatch system.

It groups passengers together who are traveling to similar floors, resulting in 25 percent faster travel time and improved building traffic. The technology in AGILE also lets you make data-driven decisions to manage your elevator performance.

You can use AGILE to integrate evolution with your building's security system or allow it to function as a stand-alone system.

AGILE touchscreen kiosks direct elevator passengers to their destination. They have clear, concise graphics, making them simple to use. The kiosks can be easily customized using your company's background and logos — or choose from pre-loaded options.

AGILE is only available on evolution 200 product line.

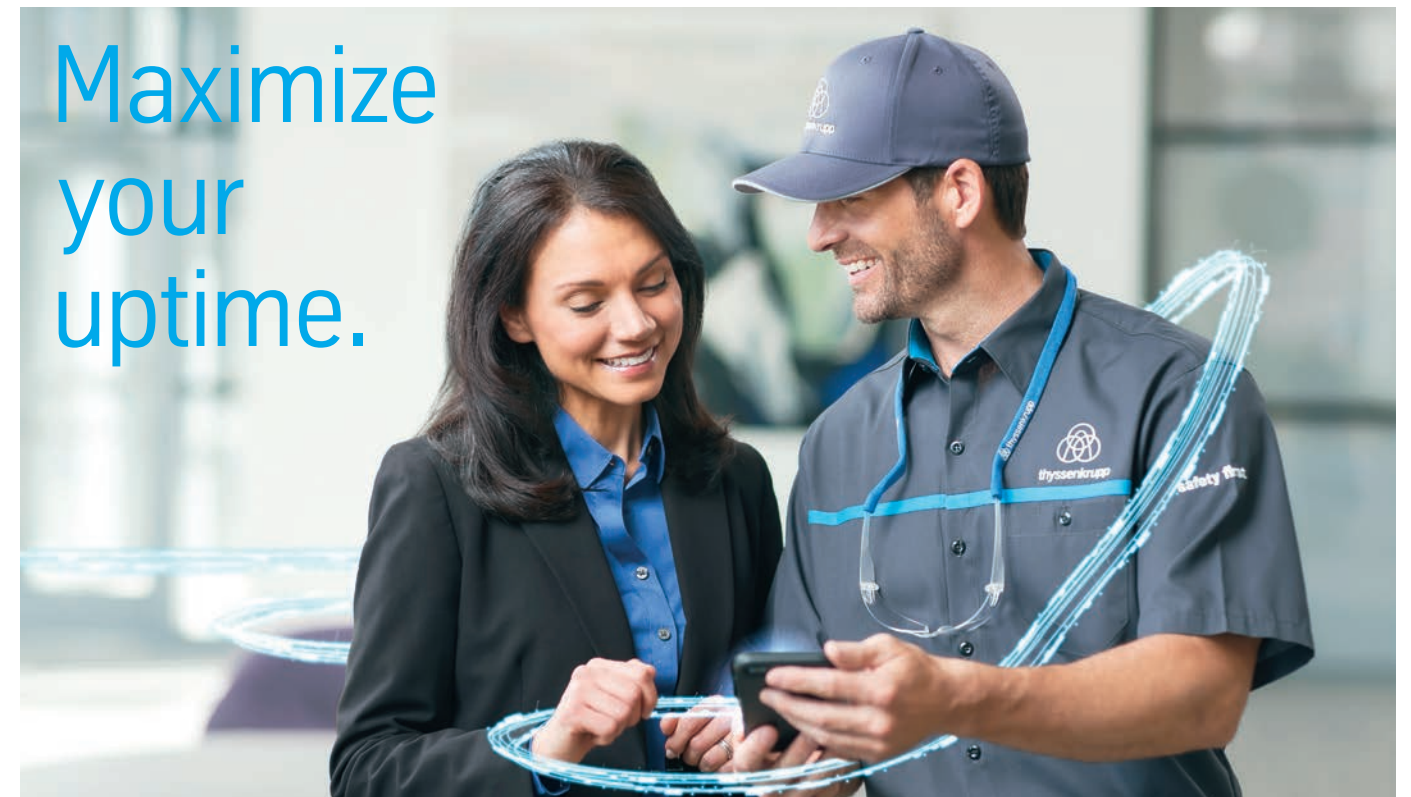

Get smarter service and less downtime with MAX.

Combining the power of cloud computing, big data and machine learning, MAX continuously collects data about your elevator's components and systems, and sends it to the cloud.

The data is analyzed, and algorithms determine when your elevator will require maintenance from our technicians.

We call this predictive maintenance. It's revolutionary and can reduce your elevator downtime by up to 50 percent. We're continuously improving MAX, so you can expect its benefits to get bigger and better over time.



MAX works onsite 24/7/365.



MAX sends equipment diagnoses.



Repairs are completed in less time.

# Our core principles.

## We deliver.

Reliable and high-quality products, services and solutions with precision and a superior cost-benefit ratio.

## We innovate.

We strive to find technology and business solutions that cater to future customer needs.

## We understand.

We listen, make suggestions, and co-develop with our customers.

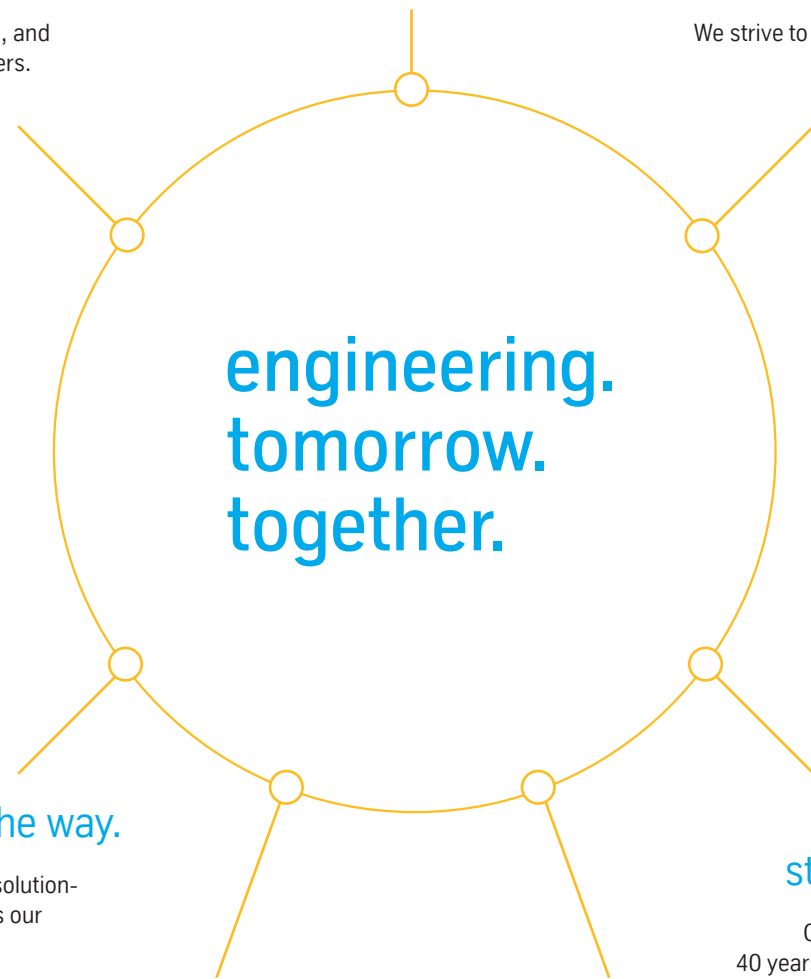

## We are leading the way.

We act with foresight and a solution-oriented mindset to progress our customers, employees and other stakeholders.

## We build on strong experience.

Our expertise is based on over 40 years of engineering competence.

## We act as a reliable partner.

We act in an honest, authentic and responsive manner towards customers, employees and other stakeholders.

## We empower our employees.

We live an innovation culture based on respect and efficient collaboration.

1,100,000

elevators and escalators under maintenance

customers in over  
**110**  
countries

**50,000+**  
employees

**Always  
there.**

Our passionate goal is to always be there to secure the reliability of mobility equipment, ensuring it provides each passenger with the safest and most comfortable travel experience, thereby helping to make cities the best ever places to live.

**1,000+**  
locations

**24/7**  
service available for  
customers

**27,000+**  
service  
technicians

# Elevator Technology

thyssenkrupp Elevator Corporation  
2591 Dallas Parkway, Suite 600  
Frisco, TX 75034  
P: +1 844 427 5461  
www.thyssenkruppelevator.com



engineering. tomorrow. together.

All illustrations and specifications are based on information in effect at time of publication approval.  
thyssenkrupp Elevator reserves the right to change specifications or design and to discontinue items without prior notice or obligation.  
© 2021 thyssenkrupp Elevator Corporation. CA License #C11-651371 | 24882 | evolution Product Overview Brochure – revised January 2021