

JACKIE ROBINSON MUSEUM

LPC SUBMISSION

V.2

75 Varick Street
Holland Plaza Building
(now One Hudson Square)

January 15, 2019

Gensler | RAA | H·Q 1

AGENDA

Project Information

- Location
- Historic Photos & LPC Designation
- Existing Conditions

Proposed Scope of Work

- Interior Scrim Wall
- Interior Entry Signage
- Banners
- Plaque

Project Location

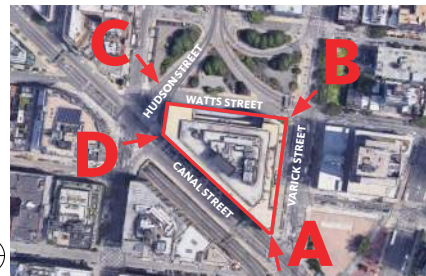

75 Varick Street | Holland Plaza Building (now One Hudson Square)
Jackie Robinson Museum | LPC Submission V.2 | January 15, 2019

Project Location



VIEW LOOKING NORTHWEST ON CANAL STREET



VIEW LOOKING NORTHEAST ON VARICK STREET

75 Varick Street | Holland Plaza Building (now One Hudson Square)
Jackie Robinson Museum LPC Submission V.2 January 15, 2019

Historic Photos and LPC Designation



Overall View, 1939

Landmarks Preservation Commission
September 24, 2013, Designation List 466
LP-2537

Holland Plaza Building (now One Hudson Square),
75 Varick Street in Manhattan
By architect Ely Jacques Kahn, 1930



Canal Street, 1939

Photo Credits: Museum of the City of New York

Existing Conditions



Hudson Street

Varick Street

Canal Street Photo Elevation



Canal Street

Watts Street

Varick Street Photo Elevation

Legend

 Jackie Robinson Museum

Existing Conditions Varick Street



75 Varick Street | Holland Plaza Building (now One Hudson Square)
Jackie Robinson Museum LPC Submission V.2 January 15, 2019

Existing Conditions Varick Street



75 Varick Street | Holland Plaza Building (now One Hudson Square)
Jackie Robinson Museum LPC Submission V.2 January 15, 2019

Existing Conditions Canal Street



75 Varick Street | Holland Plaza Building (now One Hudson Square)
Jackie Robinson Museum LPC Submission V.2 January 15, 2019

Existing Conditions Canal Street



Proposed Scope of Work Interior Scrim Wall Varick St



75 Varick Street | Holland Plaza Building (now One Hudson Square)
Jackie Robinson Museum LPC Submission V.2 January 15, 2019

Proposed Scope of Work Interior Scrim Wall Canal St



Proposed Scope of Work Interior Scrim Wall Locations

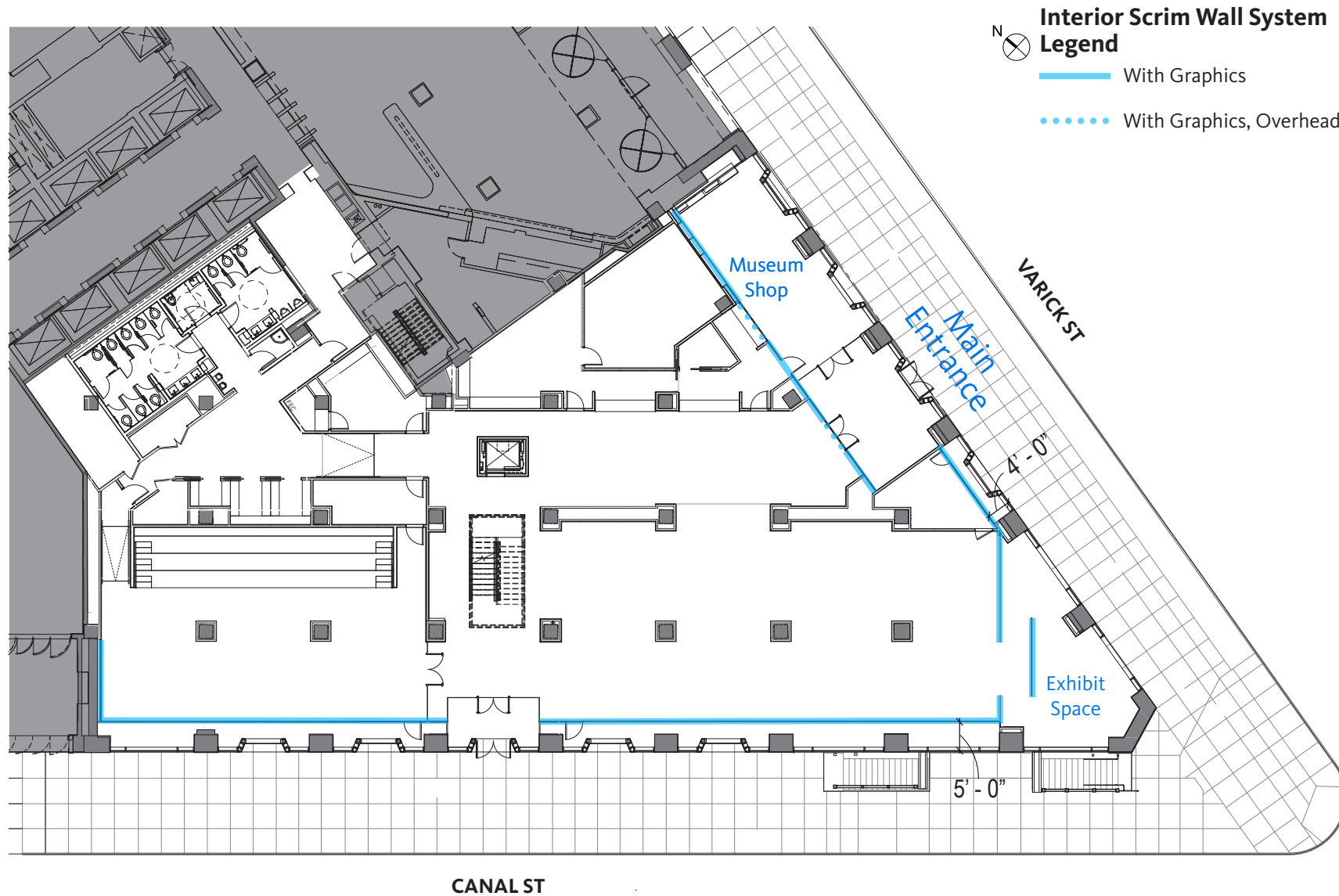

Proposed Scope of Work Interior Scrim Wall

Enlarged Plan & Section

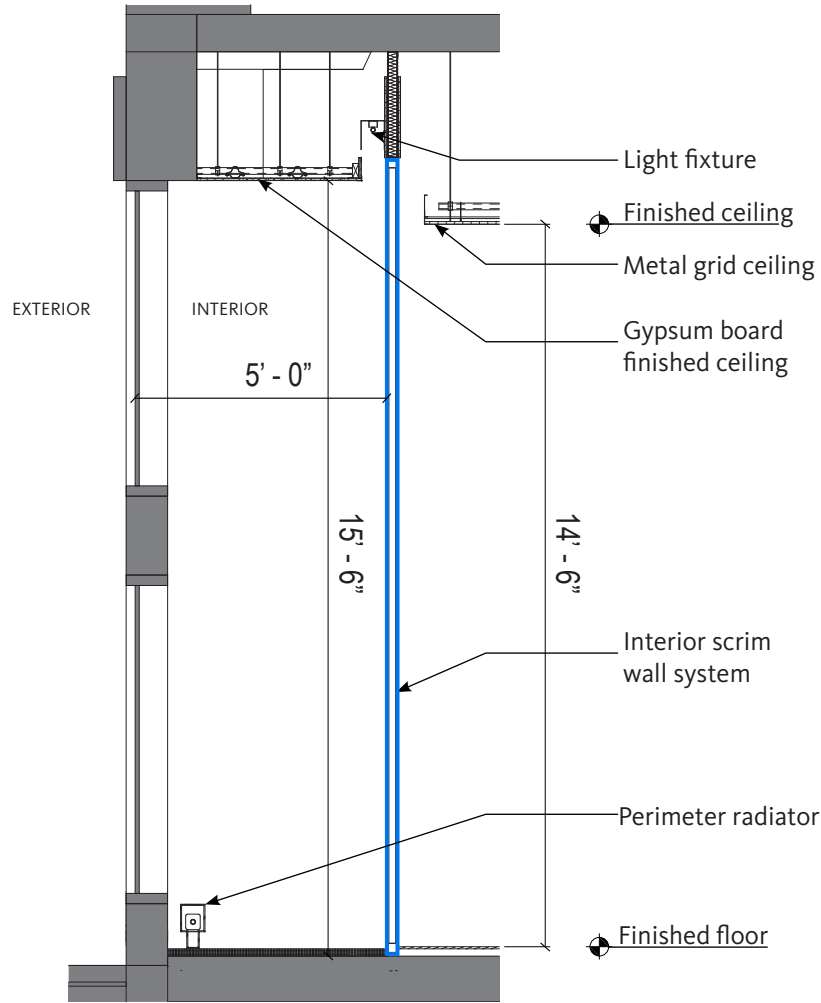
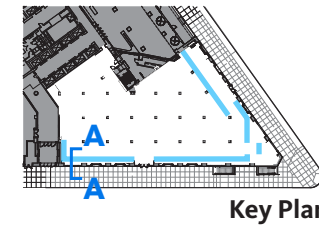

A-A Section

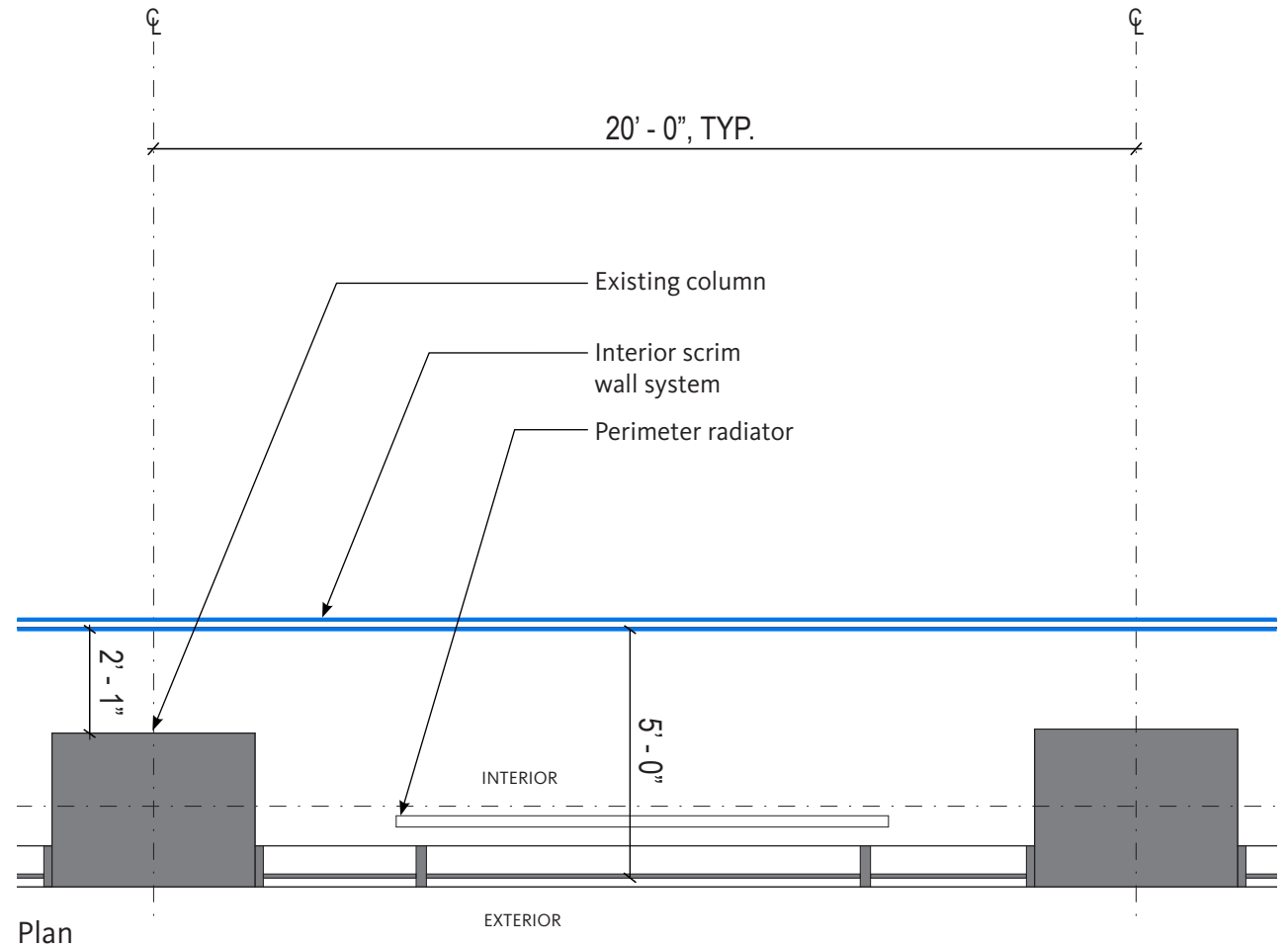

Plan

Proposed Scope of Work Interior Scrim Wall Varick St



Proposed Scope of Work Interior Scrim Wall Canal St



Proposed Scope of Work Interior Scrim Wall Canal St

Evening View



Proposed Scope of Work Interior Scrim Wall Sample Photos

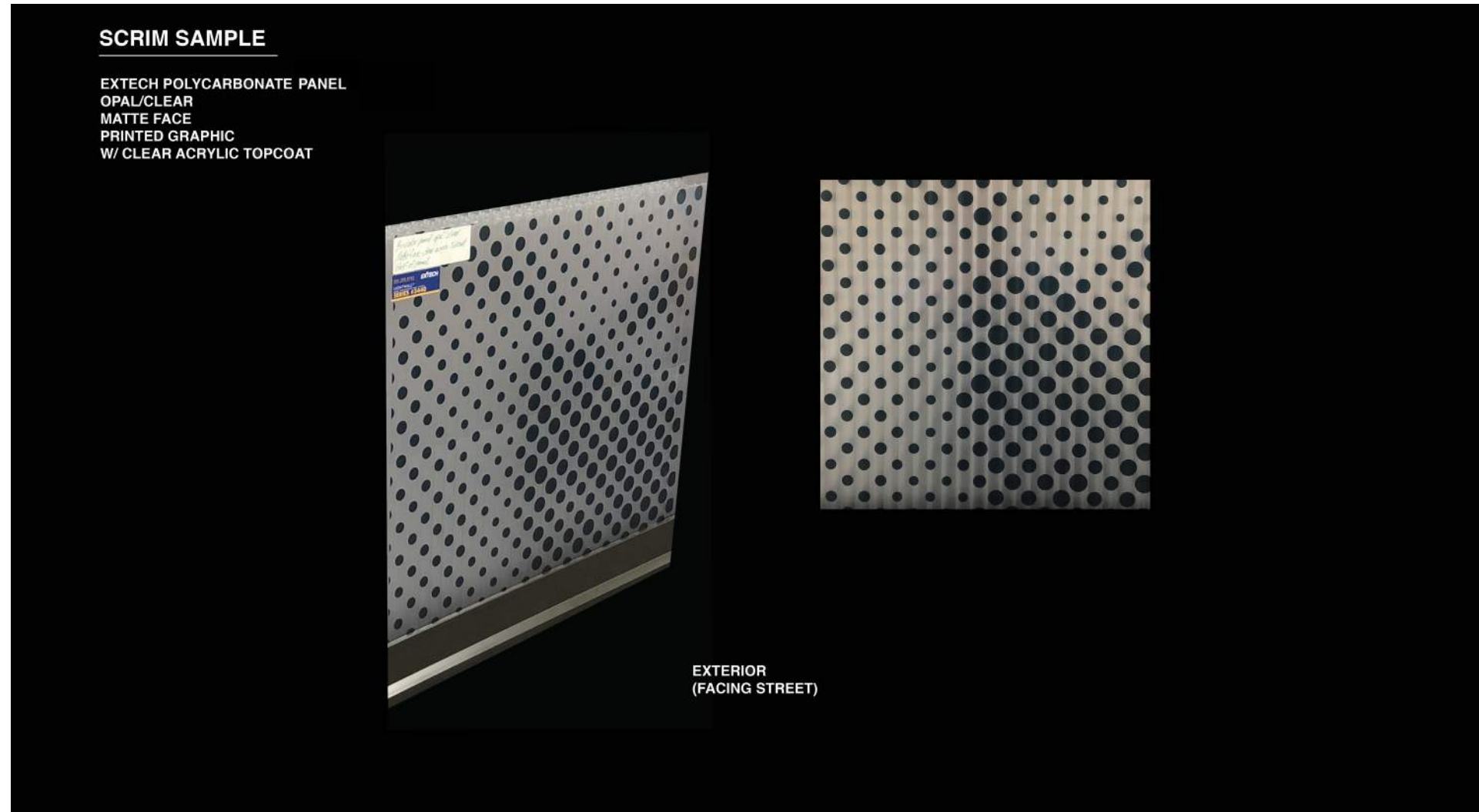

Proposed Scope of Work Interior Entry Signage Varick St



Proposed Scope of Work Interior Entry Signage

Elevation & Section

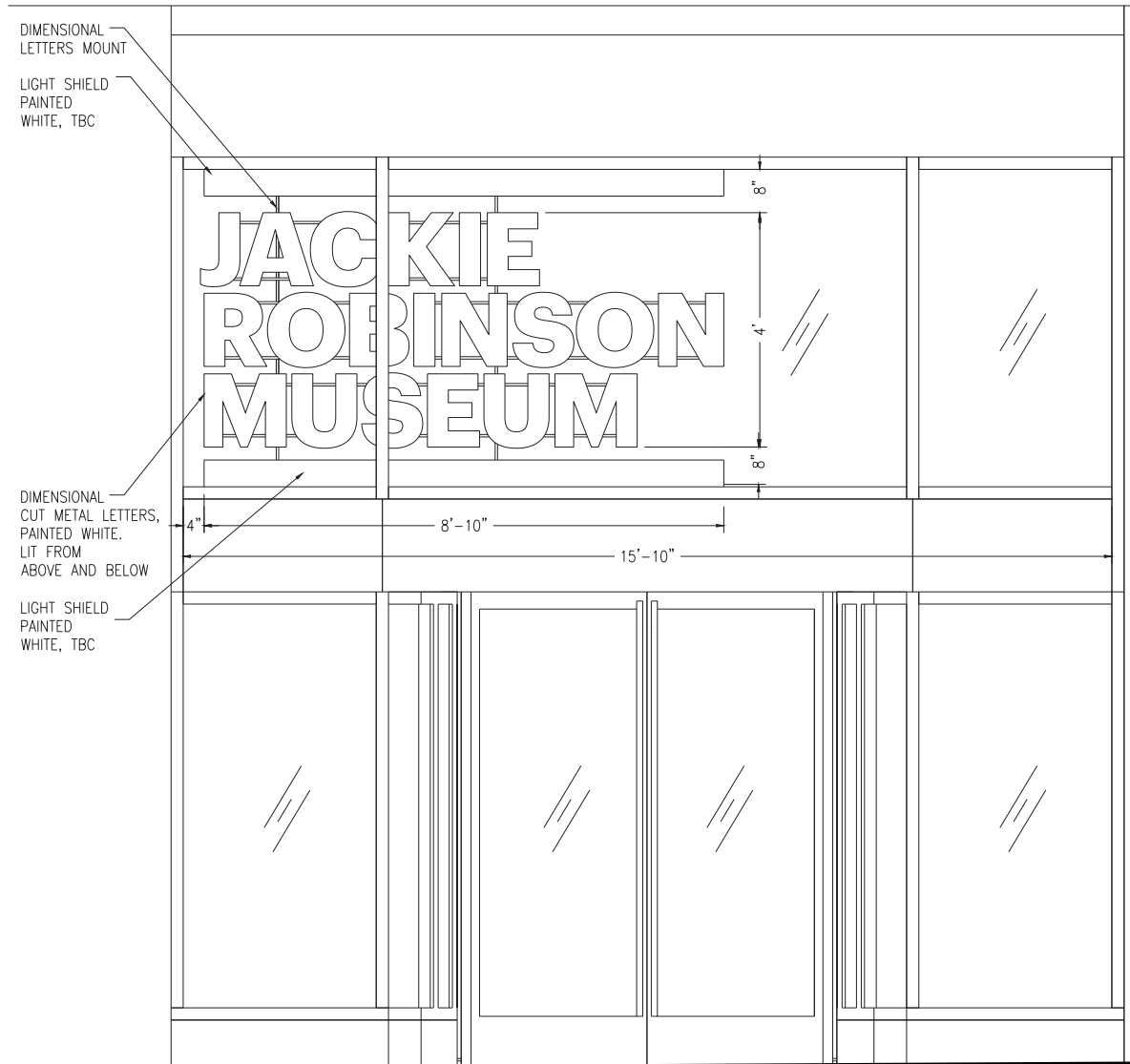

Elevation

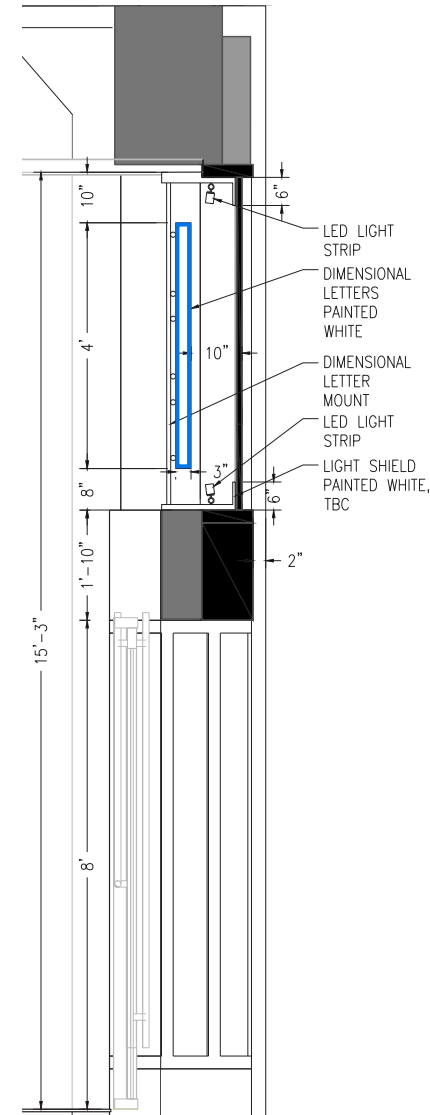

Section

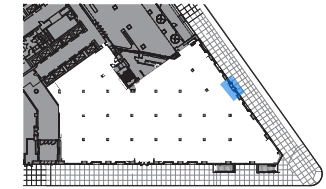

Key Plan

Note #1
Proposed dimensional letters are 33% of transom glazing.

Note #2
Proposed dimensional letters are 15% of glazing in full bay.

Proposed Scope of Work Banners Varick St



Evening View

Proposed Scope of Work Banners Locations

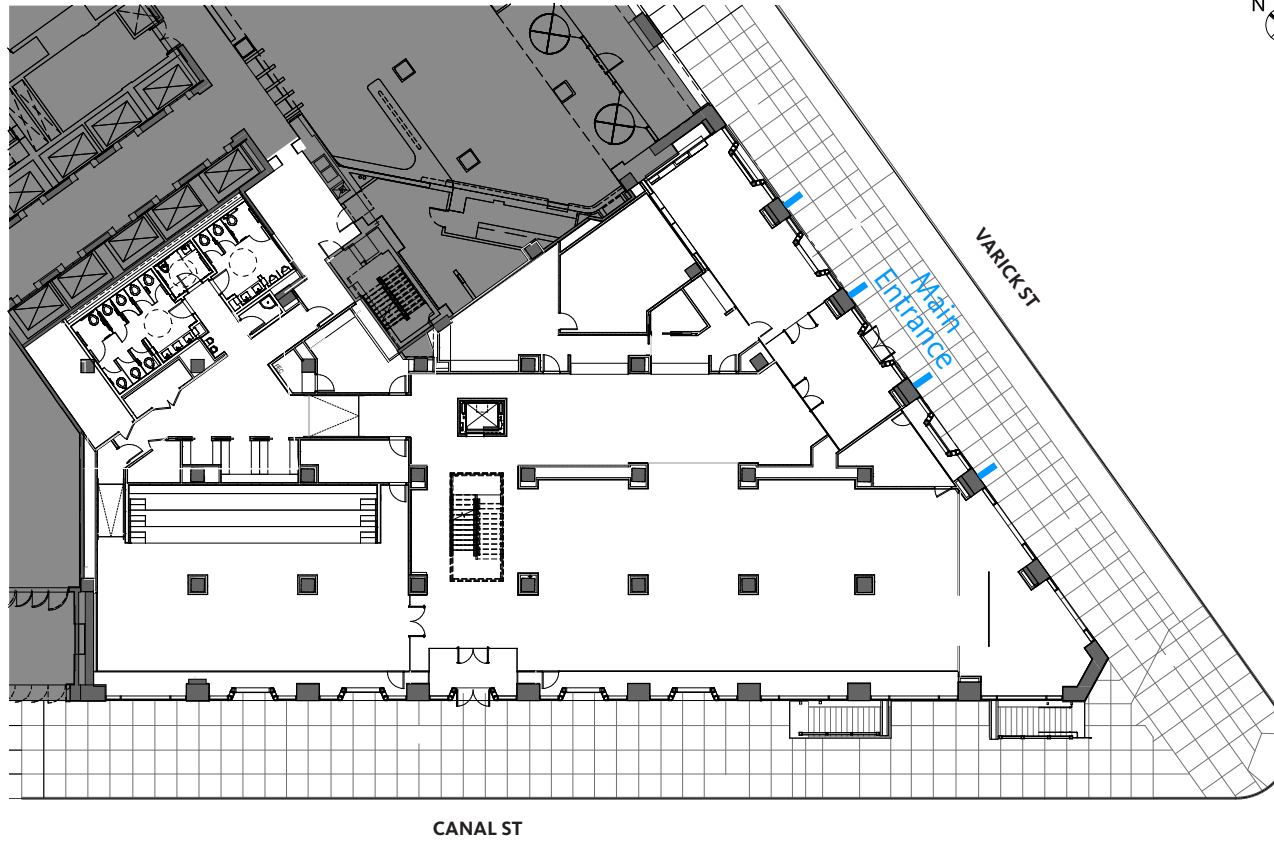
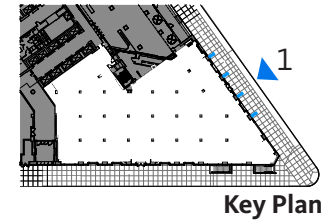

1 - VARICK ST ELEVATION - PROPOSED BANNER LOCATIONS

Proposed Scope of Work Banners Elevation & Section

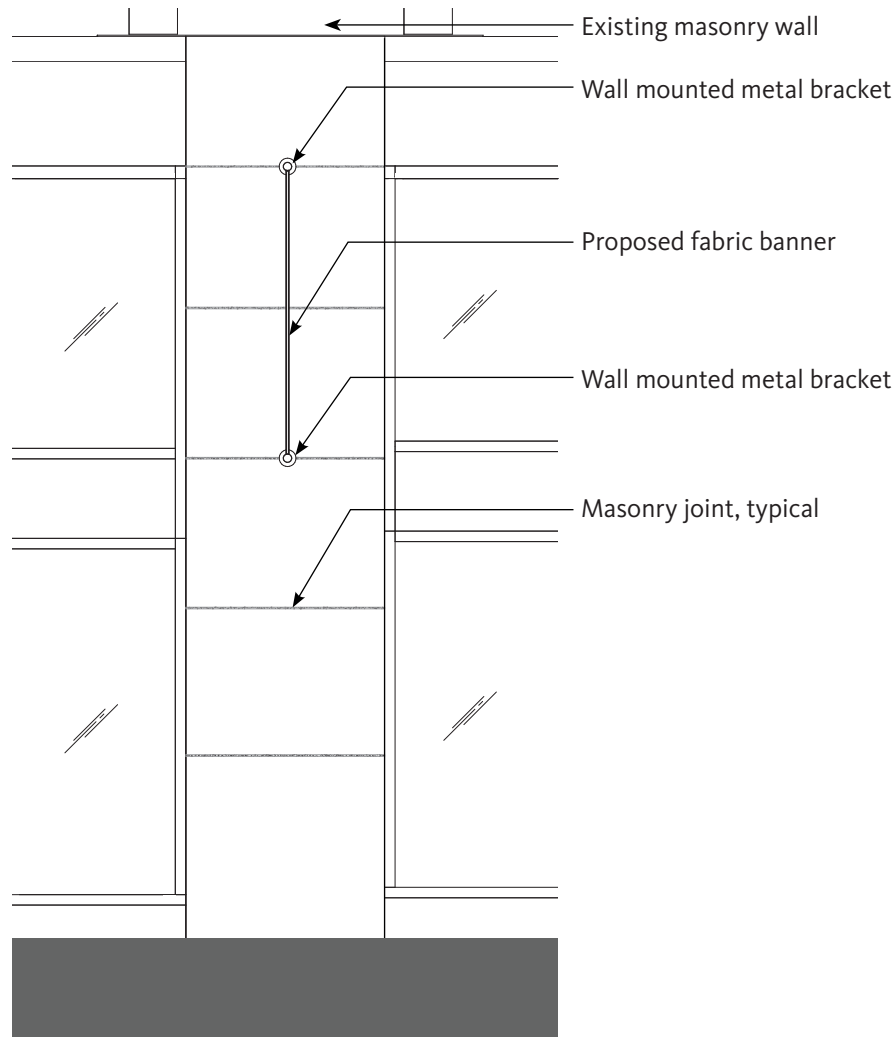

Elevation

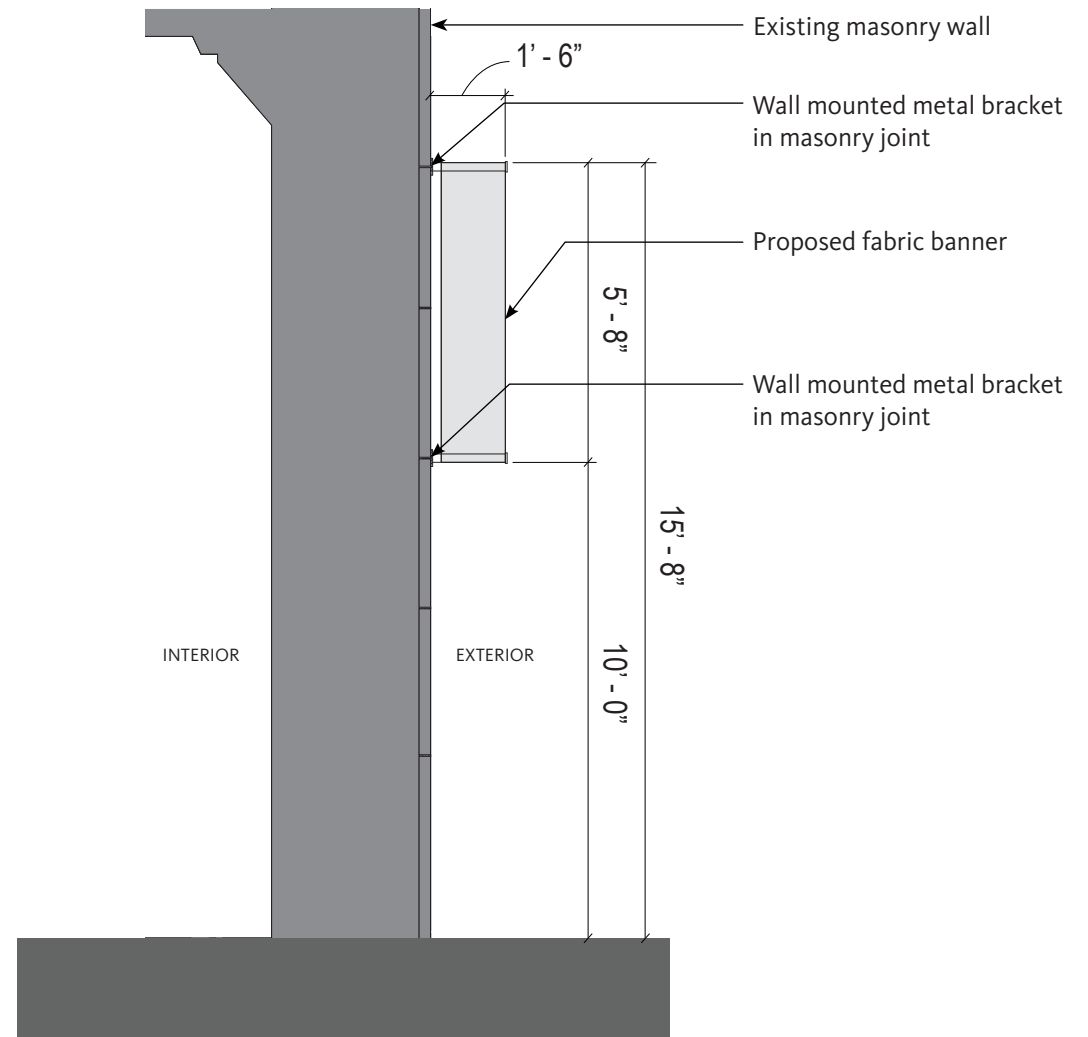

Section

Proposed Scope of Work Plaque



75 Varick Street | Holland Plaza Building (now One Hudson Square)
Jackie Robinson Museum LPC Submission V.2 January 15, 2019

Proposed Scope of Work Plaque Elevation & Section

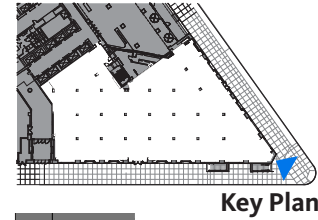

PLAQUE REFERENCE IMAGE
1" THICK ETCHED BRONZE W/ RAISED LETTERS

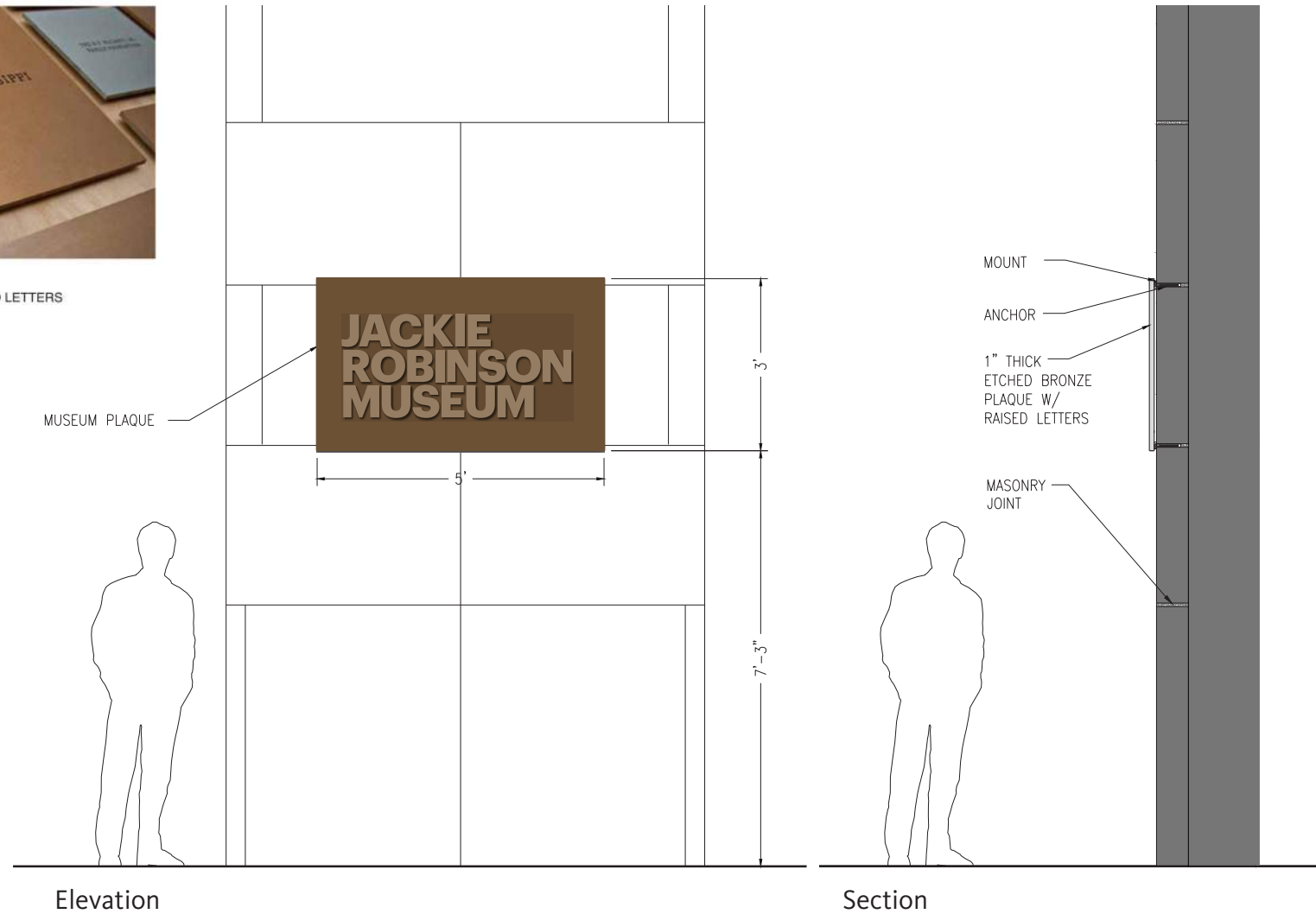

Proposed Scope of Work Canal Street



Proposed Scope of Work Varick Street



75 Varick Street | Holland Plaza Building (now One Hudson Square)
Jackie Robinson Museum LPC Submission V.2 January 15, 2019