



LPH SERIES - Liquid Ring Vacuum Pumps



SIHI Pumps
www.sihi-pumps.com

SIHI PUMPS **PERFORMANCE AND RELIABILITY**

Vacuum

*More than 29" Hg Vacuum attainable with a **single pump unit**.*

Higher Vacuum

*Achievable by incorporating **other SIHI Products**.*

Operational Safety

*Provided by the low temperature rise of the Liquid Ring Principle ensuring the **safest compression of hazardous and explosive vapors**.*

Entrained Liquid Handling

*Liquid slugs and condensables pass through the pump **without damage** and only a momentary reduction in performance.*

Long Economical Life

*Elimination of internal metallic contact minimizes maintenance and increases life - **only one moving part and no internal lubrication required**.*

Low Vibration & Noise Levels

*Absence of reciprocating parts assures **quiet and low vibration operation** - eliminating the need for special foundations.*

Low Starting Torque

*Permits considerable **savings in electrical starting and control components**.*

Construction Flexibility

*Models available in a variety of shaft seals and materials including **Cast Iron, Bronze, Stainless Steels, Hastelloys and Titanium**.*



divd.
14072
quality managem
requirements
9001
ent syste
Certification
for the foll

ted accordi
scheme

Cert. No. 97-038
QUALITY SYSTEM

Medium Vacuum Performance (Saturated Air)

Model Number (Inlet x Outlet Size) measured in inches	Vacuum in inches Hg.		4	8	12	16	20	24	26	26.4	Average Service Liquid Flow USGPM
	Absolute Pressure in Inches Hg.		25.92	21.92	17.92	13.92	9.92	5.92	3.92	3.52	
	Absolute Pressure in mm Hg.		658	557	455	354	252	150	100	89	
	Speed	Horsepower	CFM	CFM	CFM	CFM	CFM	CFM	CFM	CFM	
LPH 20103 (1¼ x 1¼)	3500	*1.5	13.8	14.6	15.2	15.2	14.4	12.2	-	-	1.0
LPH 20105 (1¼ x 1¼)	3500	2	23.9	27.6	29.7	30.5	29.3	23.7	-	-	1.0
LPH 20107 (1¼ x 1¼)	3500	3	30.0	32.7	34.3	35.1	33.1	24.8	-	-	1.1
LPH 3404 (1½ x 1½)	1150	2	20	20	19	18	10	-	-	-	3
	1750	3	41	41	41	41	42	35	-	-	3
LPH 3408 (1½ x 1½)	1150	3	41	41	39	35	24	-	-	-	3
	1750	5	76	77	77	77	77	70	-	-	3
LPH 40412 (1½ x 1½)	1750	7.5	120	120	121	122	122	110	67	-	3
LPH 40517 (2 x 2)	1750	10	167	170	171	172	170	159	118	-	5
LPH 50518 (2½ x 2½)	1150	*7.5	155	156	159	156	148	127	92	80	8
	1750	15	252	255	256	256	251	234	207	194	8
LPH 50523 (2½ x 2½)	1150	10	185	190	192	190	181	153	101	80	7
	1750	20	321	332	338	338	333	311	281	268	7
LPH 60520 (4 x 4)	1150	15	229	237	241	241	228	189	135	-	7
	1450	20	300	306	313	315	314	298	253	199	7
	1750	25	371	373	374	374	368	347	300	251	7
LPH 60527 (4 x 4)	1150	20	288	296	302	305	303	275	168	-	8
	1450	25	402	403	405	408	408	377	320	256	8
	1750	40	478	480	482	485	477	448	393	342	8
LPH 70123 (4 x 4)	880	30	463	464	466	470	460	404	320	295	10
	975	*30	511	512	515	518	505	442	370	336	10
	1030	40	550	551	554	557	544	474	382	342	10
	1150	*40	611	612	615	619	606	523	427	348	10
LPH 70530 (5 x 5)	880	40	600	602	605	609	601	577	505	416	15
	975	*40	697	699	702	697	685	636	544	467	15
	1030	50	748	750	748	743	721	674	584	479	15
	1150	60	840	837	832	821	795	739	612	490	15
LPH 70540 (5 x 5)	880	50	865	868	871	877	868	830	707	570	17
	975	60	929	932	936	942	951	911	786	684	17
	1030	60	1002	1005	1010	1017	1025	981	864	752	17
	1150	75	1140	1143	1148	1156	1145	1078	926	798	17
LPH 80540 (8 x 8)	700	75	1173	1213	1230	1228	1189	1105	1030	997	27
	735	75	1257	1284	1307	1296	1276	1195	1100	1072	27
	880	100	1462	1500	1512	1513	1490	1423	1311	1277	27
LPH 80553 (8 x 8)	700	100	1516	1564	1599	1616	1621	1537	1358	1311	31
	735	100	1628	1669	1697	1703	1699	1645	1465	1425	31
	880	125	1923	1973	2004	2013	1992	1927	1745	1704	31
LPH 80557 (8 x 8)	575	75	1638	1643	1640	1610	1568	1456	1235	1083	24
	680	100	1994	1990	1984	1951	1903	1833	1583	1299	24
	735	125	2167	2169	2168	2147	2107	2027	1774	1641	24
LPH 90554 (10 x 10)	465	100	1638	1643	1630	1610	1568	1460	1257	1140	44
	600	125	2188	2195	2204	2188	2154	2065	1875	1812	44
	700	150	2513	2521	2532	2519	2489	2372	2110	2012	44
LPH 90567 (10 x 10)	465	125	1862	1868	1871	1868	1840	1704	1414	1305	53
	600	150	2697	2705	2717	2725	2708	2610	2413	2348	53
	700	200	3032	3042	3055	3071	3064	2998	2761	2616	53
LPH 10054 (12 x 12)	410	*150	3053	3062	3076	3066	3032	2825	2245	1913	74
	490	*200	3714	3797	3865	3871	3827	3715	3368	3290	74
	565	*250	4376	4389	4408	4418	4392	4238	3929	3827	74
LPH 11055 (14 x 14)	335	250	4315	4328	4347	4367	4318	4001	2919	2348	108
	415	*300	5699	5716	5741	5729	5730	5461	4715	4364	108
	475	400	6411	6430	6459	6462	6430	6222	5500	5034	108

* Horsepower given is for motors with 1.15 service factor only. Use next larger size with 1.0 service factor motors.

This data represents average values for pumps in standard material of construction discharging against atmospheric pressure at sea level. Capacity in cubic feet per minute at inlet pressure for air with 100% saturation at 20°C (68°F) and using 15°C (59°F) water as the service liquid. When handling saturated air at higher temperatures the capacity of vacuum pumps will increase substantially; performance is available upon application.

High Vacuum Performance (Saturated Air)

Model Number (Inlet x Outlet Size) measured in inches	Vacuum in Inches Hg.		4	12	20	22.5	25	27.5	28	28.7	28.9	Average Service Liquid Flow USGPM
	Absolute Pressure in Inches Hg.		25.92	17.92	9.92	7.42	4.92	2.42	1.92	1.22	0.98	
	Absolute Pressure in mm Hg.		658	455	252	188	125	61.5	48.8	31	25	
	Speed	Horsepower	CFM	CFM	CFM	CFM	CFM	CFM	CFM	CFM	CFM	
LPH 25003 (1 ¼ x 1¼)	3500	2	13.7	14.9	15.6	15.8	15.9	14.0	14.2	11.1	-	1.4
	LPH 25007 (1¼ x 1¼)	3500	3	27.5	30.8	32.4	32.9	34.0	32.3	29.7	19.0	-
LPH 3704 (1½ x 1½)	1150	3	25	26	26	27	27	25	23	-	-	4
	1750	5	37	37	38	44	46	40	37	32	32	4
LPH 3708 (1½ x 1½)	1150	5	43	43	46	47	48	52	52	-	-	5
	1750	7.5	71	72	73	80	81	76	71	65	56	5
LPH 45312 (1½ x 1½)	1150	5	55	55	60	65	72	83	83	76	78	3
	1750	7.5	90	92	107	117	123	124	123	111	114	3
LPH 45317 (1 ½ x 1½)	1150	5	61	69	77	85	95	100	101	92	89	4
	1750	10	107	108	157	165	164	166	162	142	136	4
LPH 55312 (2 x 2)	1150	7.5	108	109	123	131	136	145	142	130	132	10
	1750	*15	143	145	185	208	218	227	224	205	218	10
LPH 55316 (2 x 2)	1150	10	114	115	141	154	162	158	153	137	141	11
	1750	20	204	205	238	259	272	280	271	235	227	11
LPH 55320 (2 x 2)	1150	15	119	120	154	167	175	174	169	167	153	13
	1750	25	210	211	258	321	345	353	343	289	275	13
LPH 65320 (2½ x 2½)	1150	15	197	199	209	223	241	268	278	276	298	9
	1450	25	270	274	298	303	318	353	349	332	354	9
	1750	30	330	333	345	361	378	390	394	371	391	9
LPH 65327 (2 ½ x 2½)	1150	20	239	238	256	271	307	341	336	316	335	9
	1450	30	326	328	345	361	383	426	433	379	372	9
	1750	40	382	384	403	419	449	481	465	403	391	9
LPH 75320 (4 x 4)	880	40	377	395	439	472	504	524	524	498	549	19
	975	40	417	425	491	531	564	585	588	577	624	19
	1030	*40	432	441	507	547	586	603	608	585	624	19
	1150	*50	453	472	538	579	624	646	633	592	633	19
LPH 75330 (4 x 4)	880	50	519	548	638	674	734	731	692	632	707	20
	975	50	575	605	701	743	811	822	795	719	726	20
	1030	60	590	636	732	775	844	847	814	766	735	20
	1150	75	605	672	779	818	909	889	860	743	745	20
LPH 75340 (4 x 4)	880	50	677	682	732	802	931	987	957	806	856	21
	975	60	748	759	836	902	1019	1102	1086	948	949	21
	1030	*60	773	789	873	940	1046	1127	1112	995	977	21
	1150	100	814	841	931	998	1090	1163	1151	1027	977	21
LPH 85340 (6 x 6)	700	100	1094	1138	1218	1253	1293	1346	1299	1232	1294	38
	735	100	1140	1205	1276	1306	1353	1437	1396	1359	1424	38
	880	125	1323	1358	1506	1555	1632	1766	1778	1596	1564	38
LPH 85353 (6 x 6)	700	*100	1297	1323	1464	1550	1632	1778	1758	1706	1824	50
	735	125	1348	1374	1495	1582	1687	1851	1810	1801	1917	50
	880	150	1526	1589	1767	1869	1994	2156	2081	1975	2103	50
LPH 95354 (8 x 8)	465	125	1364	1507	1715	1794	1873	1985	2004	1927	1917	71
	600	*150	1994	2030	2164	2230	2301	2412	2456	2275	2196	71
	700	*200	2366	2440	2572	2622	2706	2777	2754	2607	2411	71
LPH 95367 (8 x 8)	465	125	1567	1640	1851	1985	2169	2412	2495	2607	2411	76
	600	200	2086	2184	2426	2612	2783	2984	3025	3002	2848	76
	700	250	2463	2563	2781	2952	3133	3374	3413	3413	3071	76
LPH 10534 (8 x 8)	400	200	2519	2563	2781	3026	3265	3593	3684	3713	3676	108
	490	*250	3185	3255	3555	3865	4108	4385	4460	4424	4207	108
	590	350	3638	3768	4182	4480	4765	5091	5107	4898	4607	108
LPH 11535 (10 x 10)	335	*250	3592	3629	3994	4300	4678	5237	5326	5372	5370	147
	415	*350	4600	4767	5176	5500	5872	6455	6503	6162	6031	147
	470	450	4884	5177	5793	6105	6628	7125	7201	6952	6515	147

* Horsepower given is for motors with 1.15 service factor only. Use next larger size with 1.0 service factor motors.

This data represents average values for pumps in standard material of construction discharging against atmospheric pressure at sea level. Capacity in cubic feet per minute at inlet pressure for air with 100% saturation at 20°C (68°F) and using 15°C (59°F) water as the service liquid. When handling saturated air at higher temperatures the capacity of vacuum pumps will increase substantially; performance is available upon application.

IF REQUIREMENTS ARE IN THE DARK BLUE AREA, A MORE EFFICIENT SELECTION CAN BE MADE FROM PUMPS LISTED ON PRECEDING PAGE.

Medium Vacuum Performance (Dry Air)

Model Number (Inlet x Outlet Size) measured in inches	Vacuum in inches Hg.		4	8	12	16	20	24	26	26.4	Average Service Liquid Flow USGPM
	Absolute Pressure in Inches Hg.		25.92	21.92	17.92	13.92	9.92	5.92	3.92	3.52	
	Absolute Pressure in mm Hg.		658	557	455	354	252	150	100	89	
	Speed	Horsepower	CFM	CFM	CFM	CFM	CFM	CFM	CFM	CFM	
LPH 20103 (1¼ x 1¼)	3500	*1.5	13.6	14.3	14.8	14.7	13.8	11.3	-	-	1.0
LPH 20105 (1¼ x 1¼)	3500	2	23.5	27.0	29.0	29.5	28.0	22.0	-	-	1.0
LPH 20107 (1¼ x 1¼)	3500	3	29.5	32.0	33.5	34.0	31.7	23.0	-	-	1.1
LPH 3404 (1½ x 1½)	1150	2	20	20	19	17	10	-	-	-	3
	1750	3	40	40	40	40	40	32	-	-	3
LPH 3408 (1½ x 1½)	1150	3	40	40	38	34	23	-	-	-	3
	1750	5	75	75	75	75	74	65	-	-	3
LPH 40412 (1½ x 1½)	1750	7.5	118	118	118	118	117	102	60	-	3
LPH 40517 (2 x 2)	1750	10	164	167	167	167	163	147	105	-	5
LPH 50518 (2½ x 2½)	1150	*7.5	152	153	155	151	142	118	82	70	8
	1750	15	248	250	250	248	240	217	184	170	8
LPH 50523 (2½ x 2½)	1150	10	182	186	187	184	173	142	90	70	7
	1750	20	315	325	330	327	318	288	250	235	7
LPH 60520 (4 x 4)	1150	15	225	232	235	233	218	175	120	-	7
	1450	20	295	300	305	305	300	276	225	175	7
	1750	25	365	365	365	362	352	322	267	220	7
LPH 60527 (4 x 4)	1150	20	283	290	295	295	290	255	150	-	8
	1450	25	395	395	395	395	390	350	285	225	8
	1750	40	470	470	470	470	456	415	350	300	8
LPH 70123 (4 x 4)	880	30	455	455	455	455	440	375	285	259	10
	975	*30	502	502	502	502	483	410	330	295	10
	1030	40	540	540	540	540	520	440	340	300	10
	1150	*40	600	600	600	600	580	485	380	305	10
LPH 70530 (5 x 5)	880	40	590	590	590	590	575	535	450	365	15
	975	*40	685	685	685	675	655	590	485	410	15
	1030	50	735	735	730	720	690	625	520	420	15
	1150	60	825	820	812	795	760	685	545	430	15
LPH 70540 (5 x 5)	880	50	850	850	850	850	830	770	630	500	17
	975	60	913	913	913	913	910	845	700	600	17
	1030	60	985	985	985	985	980	910	770	660	17
	1150	75	1120	1120	1120	1120	1095	1000	825	700	17
LPH 80540 (8 x 8)	700	75	1153	1188	1200	1190	1137	1025	918	875	27
	735	75	1235	1258	1275	1255	1220	1108	980	940	27
	880	100	1437	1470	1475	1466	1425	1320	1168	1120	27
LPH 80553 (8 x 8)	700	100	1490	1532	1560	1565	1550	1425	1210	1150	31
	735	100	1600	1635	1655	1650	1625	1525	1305	1250	31
	880	125	1890	1933	1955	1950	1905	1787	1555	1495	31
LPH 80557 (8 x 8)	575	75	1610	1610	1600	1560	1500	1350	1100	950	24
	680	100	1960	1950	1935	1890	1820	1700	1410	1140	24
	735	125	2130	2125	2115	2080	2015	1880	1580	1440	24
LPH 90554 (10 x 10)	465	100	1610	1610	1590	1560	1500	1354	1120	1000	44
	600	125	2150	2150	2150	2120	2060	1915	1670	1590	44
	700	150	2470	2470	2470	2440	2380	2200	1880	1765	44
LPH 90567 (10 x 10)	465	125	1830	1830	1825	1810	1760	1580	1260	1145	53
	600	150	2650	2650	2650	2640	2590	2420	2150	2060	53
	700	200	2980	2980	2980	2975	2930	2780	2460	2295	53
LPH 10054 (12 x 12)	410	*150	3000	3000	3000	2970	2900	2620	2000	1678	74
	490	*200	3650	3720	3770	3750	3660	3445	3000	2886	74
	565	*250	4300	4300	4300	4280	4200	3930	3500	3357	74
LPH 11055 (14 x 14)	335	250	4240	4240	4240	4230	4130	3710	2600	2060	108
	415	*300	5600	5600	5600	5550	5480	5064	4200	3828	108
	475	400	6300	6300	6300	6260	6150	5770	4900	4416	108

* Horsepower given is for motors with 1.15 service factor only. Use next larger size with 1.0 service factor motors.

This data represents average values for pumps in standard material of construction discharging against atmospheric pressure at sea level. Capacity in cubic feet per minute at inlet pressure for air at 20°C (68°F) and using 15°C (59°F) water as the service liquid. When handling 100% saturated air see performance data on following pages.

High Vacuum Performance (Dry Air)

Model Number (Inlet x Outlet Size) measured in inches	Vacuum in Inches Hg.		4	12	20	22.5	25	27.5	28	28.7	28.9	Average Service Liquid Flow USGPM
	Absolute Pressure in Inches Hg.		25.92	17.92	9.92	7.42	4.92	2.42	1.92	1.22	0.98	
	Absolute Pressure in mm Hg.		658	455	252	188	125	61.5	48.8	31	25	
	Speed	Horsepower	CFM	CFM	CFM	CFM	CFM	CFM	CFM	CFM	CFM	
LPH 25003 (1¼ x 1¼)	3500	2	13.5	14.5	14.9	14.9	14.5	11.5	11.0	7.0	-	1.4
	LPH 25007 (1¼ x 1¼)	3500	3	27.0	30.0	31.0	31.0	31.0	26.5	23.0	12.0	-
LPH 3704 (1½ x 1½)	1150	3	25	25	25	25	25	21	18	-	-	4
	1750	5	37	37	37	42	42	33	29	20	17	4
LPH 3708 (1½ x 1½)	1150	5	42	42	44	44	44	43	40	-	-	5
	1750	7.5	70	70	70	75	74	62	55	41	30	5
LPH 45312 (1½ x 1½)	1150	5	54	54	57	61	66	68	64	48	42	3
	1750	7.5	88	90	102	110	112	102	95	70	61	3
LPH 45317 (1½ x 1½)	1150	5	60	67	74	80	87	82	78	58	48	4
	1750	10	105	105	150	155	150	136	125	90	73	4
LPH 55312 (2 x 2)	1150	7.5	106	106	118	123	124	119	110	82	71	10
	1750	*15	141	141	177	196	199	186	173	130	117	10
LPH 55316 (2 x 2)	1150	10	112	112	135	145	148	130	118	87	76	11
	1750	20	200	200	228	244	248	230	210	149	122	11
LPH 55320 (2 x 2)	1150	15	117	117	147	157	160	143	131	106	82	13
	1750	25	206	206	247	302	315	290	265	183	148	13
LPH 65320 (2½ x 2½)	1150	15	194	194	200	210	220	220	215	175	160	9
	1450	25	265	267	285	285	290	290	270	210	190	9
	1750	30	324	325	330	340	345	320	305	235	210	9
LPH 65327 (2½ x 2½)	1150	20	235	232	245	255	280	280	260	200	180	9
	1450	30	320	320	330	340	350	350	335	240	200	9
	1750	40	375	375	385	395	410	395	360	255	210	9
LPH 75320 (4 x 4)	880	40	370	385	420	445	460	430	405	315	295	19
	975	40	410	415	470	500	515	480	455	365	335	19
	1030	*40	425	430	485	515	535	495	470	370	335	19
	1150	*50	445	460	515	545	570	530	490	375	340	19
LPH 75330 (4 x 4)	880	50	510	535	610	635	670	600	535	400	380	20
	975	50	565	590	670	700	740	675	615	455	390	20
	1030	60	580	620	700	730	770	695	630	485	395	20
	1150	75	595	655	745	770	830	730	665	470	400	20
LPH 75340 (4 x 4)	880	50	665	665	700	755	850	810	740	510	460	21
	975	60	735	740	800	850	930	905	840	600	510	21
	1030	*60	760	770	835	885	955	925	860	630	525	21
	1150	100	800	820	890	940	995	955	890	650	525	21
LPH 85340 (6 x 6)	700	100	1075	1110	1165	1180	1180	1105	1005	780	695	38
	735	100	1120	1175	1220	1230	1235	1180	1080	860	765	38
	880	125	1300	1325	1440	1465	1490	1450	1375	1010	840	38
LPH 85353 (6 x 6)	700	*100	1275	1290	1400	1460	1490	1460	1360	1080	980	50
	735	125	1325	1340	1430	1490	1540	1520	1400	1140	1030	50
	880	150	1500	1550	1690	1760	1820	1770	1610	1250	1130	50
LPH 95354 (8 x 8)	465	125	1340	1470	1640	1690	1710	1630	1550	1220	1030	71
	600	*150	1960	1980	2070	2100	2100	1980	1900	1440	1180	71
	700	*200	2325	2380	2460	2470	2470	2280	2130	1650	1295	71
LPH 95367 (8 x 8)	465	125	1540	1600	1770	1870	1980	1980	1930	1650	1295	76
	600	200	2050	2130	2320	2460	2540	2450	2340	1900	1530	76
	700	250	2420	2500	2660	2780	2860	2770	2640	2160	1650	76
LPH 10534 (8 x 8)	400	200	2475	2500	2660	2850	2980	2950	2850	2350	1975	108
	490	*250	3130	3175	3400	3640	3750	3600	3450	2800	2260	108
	590	350	3575	3675	4000	4220	4350	4180	3950	3100	2475	108
LPH 11535 (10 x 10)	335	*250	3530	3540	3820	4050	4270	4300	4120	3400	2885	147
	415	*350	4520	4650	4950	5180	5360	5300	5030	3900	3240	147
	470	450	4800	5050	5540	5750	6050	5850	5570	4400	3500	147

* Horsepower given is for motors with 1.15 service factor only. Use next larger size with 1.0 service factor motors.

This data represents average values for pumps in standard material of construction discharging against atmospheric pressure at sea level. Capacity in cubic feet per minute at inlet pressure for air at 20°C (68°F) and using 15°C (59°F) water as the service liquid. When handling 100 % saturated air see performance data on following pages.

IF REQUIREMENTS ARE IN THE DARK BLUE AREA, A MORE EFFICIENT SELECTION CAN BE MADE FROM PUMPS LISTED ON PRECEDING PAGE.

SINGLE ACTING LIQUID RING PUMPS

In a round pump body (A), a shaft mounted impeller (B) is positioned at a point eccentric to the centerline of the pump body. The centrifugal action of the rotating impeller forces the service liquid introduced via channel (D) towards the periphery of the pump body forming the liquid ring (C).

When pumping action is achieved, the gas mixture being handled is introduced to the impeller through the suction port (H), in the intermediate plate (E), causing a vacuum at the pump suction. The gas mixture fills the impeller cavity between the inside diameter of the liquid ring and the root of the impeller blade. As the impeller rotates,

the impeller blade immersion in the liquid ring increases reducing the volume between the liquid ring and the root of the impeller blade. The result is the compression of the gas mixture until it reaches the discharge port (J), located in the intermediate plate (K). The gas mixture exits through the discharge port.

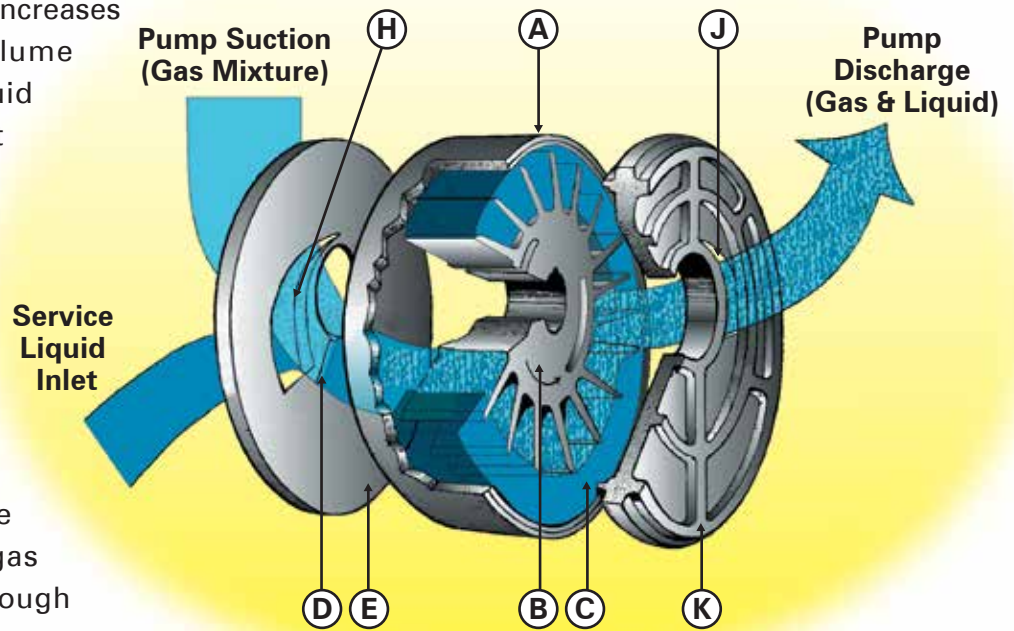

- = Gas Mixture
- = Service Liquid
- ● = Gas & Liquid

During the compression cycle heat is being imparted to the liquid ring. In order to maintain a temperature below the vapor point of the service liquid, cooling must be applied. Cooling is achieved by continuously adding a cool supply of service liquid to the liquid ring. The amount of service liquid added is equal to that discharged through the discharge port (J) together with the compressed gas mixture. The gas mixture and service liquid is eventually passed through the pump discharge for separation.

★ *The illustration is intended to depict the operating principle of the SIHI liquid ring pump only and should not be considered for engineering details of construction.*

SERVICE LIQUID ARRANGEMENTS

ONCE THROUGH

Used where service liquid is plentiful and contamination is not a problem.

Benefits

- Simplicity
- Lowest initial cost

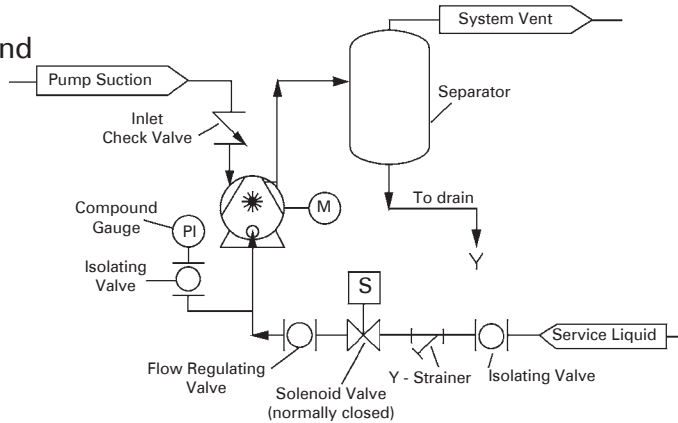

PARTIAL RECIRCULATION

Used where service liquid is available and contamination problems are minimal.

Benefits

- Simplicity
- Low initial cost
- Reduced service liquid consumption

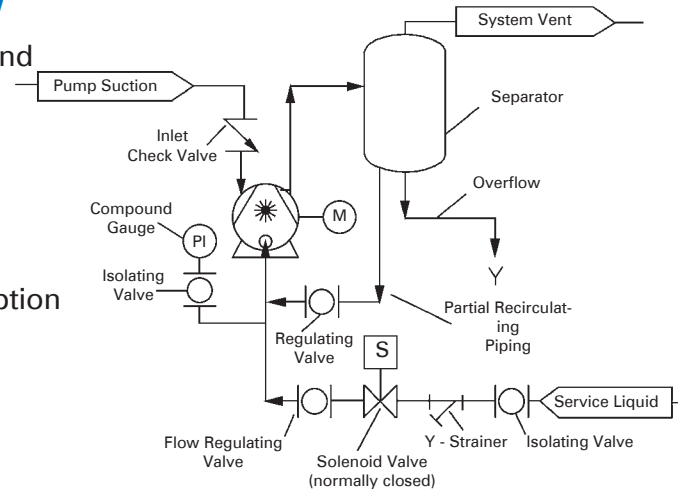

TOTAL RECIRCULATION

Used where gases and liquids are toxic or hazardous, and when environmental contamination is a concern.

Benefits

- Service liquid contained and separated from nonhazardous coolant systems
- Low service liquid usage
- Allows recovery of condensable inlet gases

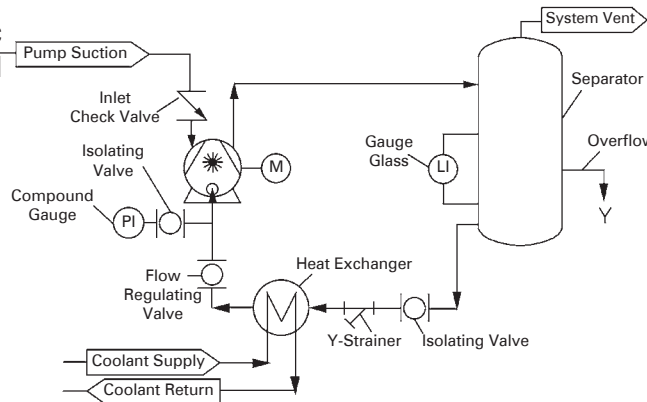

Accessories for the above service liquid arrangements can be provided by SIHI Pumps in completely piped, assembled and tested factory packages.

SERVICE LIQUID



LPH SERIES LIQUID RING VACUUM PUMPS

ENGINEERED PACKAGES



SINGLE SOURCE RESPONSIBILITY:



Purchase Order



Contact



Warranty



SIHI Pumps has competent engineering teams backed by more than sixty years experience to design and build packages custom suited to your requirements.



CHEMICAL

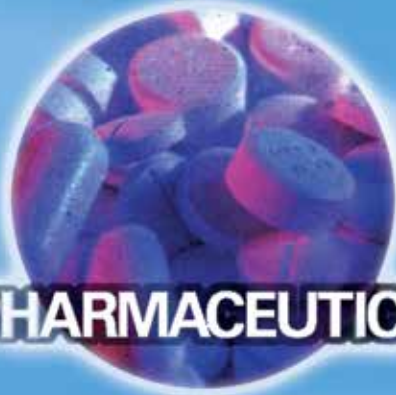

PHARMACEUTICAL



PLASTICS



ELECTRONICS

TYPICAL APPLICATIONS

- Drying
- Distillation
- Evaporation Crystallization
- Vapor Recovery
- Deaeration
- Sterilization
- Filtration
- Evisceration
- Impregnation
- Extrusion
- Condensor Exhaust
- Vacuum Conveyance
- Priming
- Vacuum Packaging
- Central Vacuum Systems



FOOD & BEVERAGE

**MAJOR INDUSTRIES
& APPLICATIONS**



LPH SERIES - Liquid Ring Vacuum Pumps

SIHI Pumps, Inc.
303 Industrial Dr.
Grand Island, NY 14072
Telephone: (716) 773-6450
Fax: (716) 773-2330

SIHI Pumps, Inc.
5757 Genoa-Red Bluff Road
Pasadena, Texas 77507-1044
Telephone: (281) 991-3100
Fax: (281) 991-3101

SIHI Pumps Limited
225 Speedvale Avenue W.
Guelph, Ont. Canada N1H 6L8
Telephone: (519) 824-4600
Fax: (519) 824-7250



www.sihi-pumps.com