



LuK Repair Solution for double clutch transmissions



Disassembly and assembly
Special tool/Failure diagnosis

Ford DPS6



The content of this brochure shall not be legally binding and is for information purposes only. To the extent legally permissible, Schaeffler Automotive Aftermarket GmbH & Co. KG assumes no liability out of or in connection with this brochure.

Copyright ©
Schaeffler Automotive Aftermarket GmbH & Co. KG
April 2017

All rights reserved. Any copying, distribution, reproduction, making publicly available or other publication of this brochure in whole or in extracts without the prior written consent of Schaeffler Automotive Aftermarket GmbH & Co. KG is prohibited.

Schaeffler in the Automotive Aftermarket – more innovation, more quality and more service.

Schaeffler in the Automotive Aftermarket – four strong brands.

Whenever a vehicle needs to go to the garage, our products and repair solutions are usually first choice to fix them. With our four strong brands LuK, INA, FAG, and Ruville, we are a reliable global partner – offering repair solutions for passenger cars, light and heavy commercial vehicles as well as tractors.

Whether for the transmission, engine, or chassis – all products are based on a comprehensive systems approach. Innovation, technical expertise, and the highest material and manufacturing quality make us not only one of the leading development partners for vehicle manufacturers, but also a pioneering provider of value-retaining spare parts and complete repair solutions – always in original equipment quality. Our comprehensive portfolio includes products and repair solutions for clutches and clutch release systems, engine and transmission applications, and chassis applications. All components are optimally tuned to work together perfectly, and allow fast and professional parts replacement.

For over 50 years, Schaeffler has offered everything needed for transmission repair. With its LuK RepSet family (LuK RepSet, LuK RepSet Pro, LuK RepSet DMF, and LuK RepSet 2CT) Schaeffler supports garages with professional clutch repair. The portfolio includes the entire hydraulic release system and the dual-mass flywheel.



Schaeffler REPERT – the service brand for garage professionals.

Under the REPERT brand we offer a comprehensive package of services for the products and repair solutions of the LuK, INA, FAG, and Ruville brands. Looking for specific information or damage diagnosis? Are you in need of particular tools to make your everyday garage routine easier? Whether online portal, service hotline, installation instructions and videos, training seminars, or events – all technical services are provided in just one place.

Then simply register for free in just a few clicks at: www.repxpert.com.

SCHAEFFLER
REPERT



Special tools

Tool kit (400 0477 10) for professional repair of the Ford DPS6 gearbox.

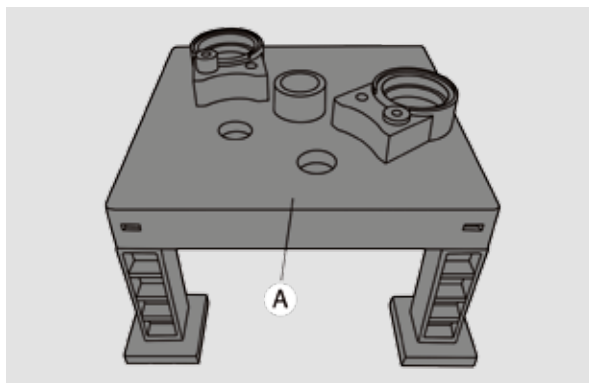

Assembly table:

- Table (A) for securing the shafts, gear shift positions and controller drums.
- For use during disassembly and assembly.

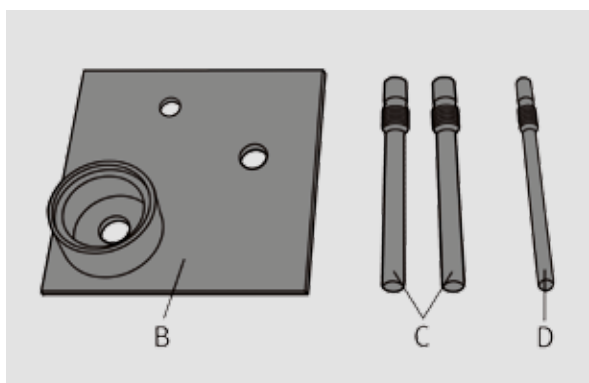

Shaft holder:

- Plate (B) and pins (C/D) for securing the drive and output shafts.
- 2 x pin (C) for output shafts.
- 1 x pin (D) for drive shaft.

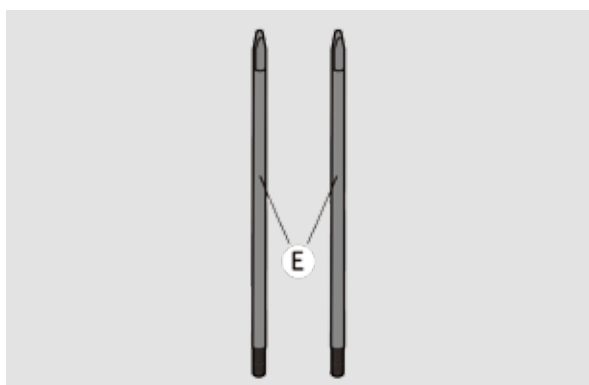

Guide pins:

- Pins (E) for guiding the retaining plates on the output shaft bearings.

Note:

Additional special tools from LuK are required for the disassembly and assembly of the Ford dry double clutch:

- Basic tool kit (400 0418 10)
- Ford tool kit (400 0427 10)

Repair Manual for the Ford DPS6 gearbox

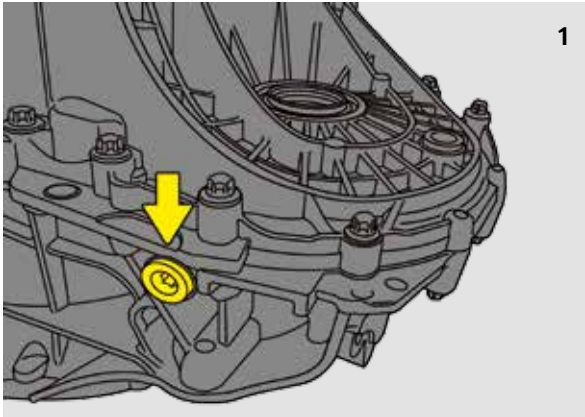

- Drain the gearbox oil.
- Remove the gearbox from the vehicle in accordance with the vehicle manufacturer specifications.
- Replace the o-ring of the oil drain plug.
- Mount the oil drain plug (arrow). Tightening torque of the oil drain plug: 43 Nm

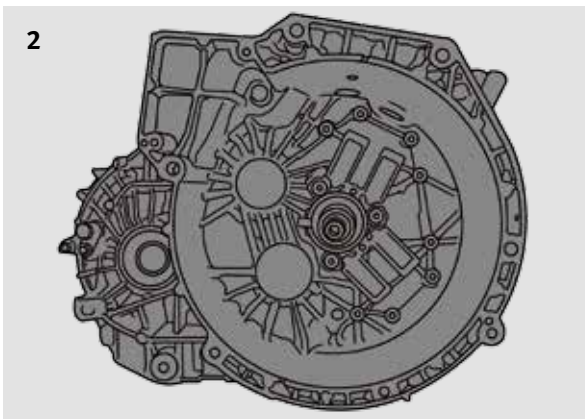

- Disassemble the double clutch, lever actuators and guiding sleeve as described in the LuK RepSet 2CT repair instructions (999 6006 570) for the Ford DPS6 gearbox.

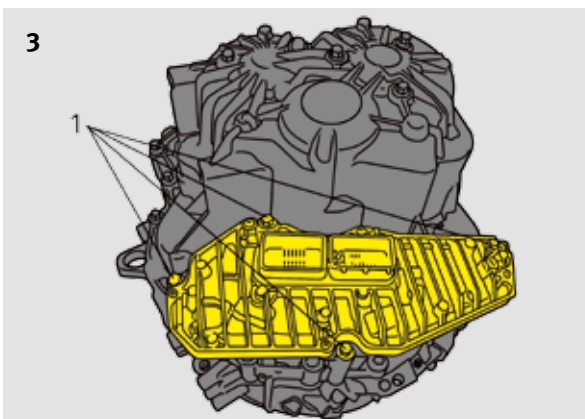

- Loosen the screws (1) in the mechatronics.
- Disassemble the mechatronics.

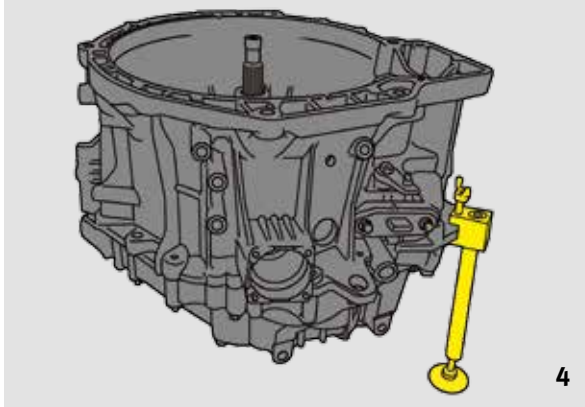

- Mount the stand from the LuK basic tool kit for dry double clutches (400 0418 10).

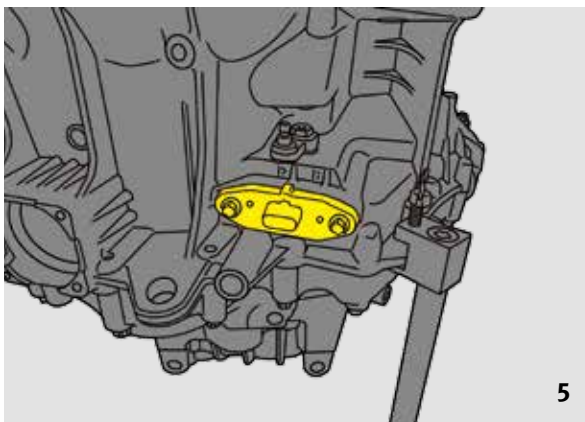

- Remove the parking lock switch.

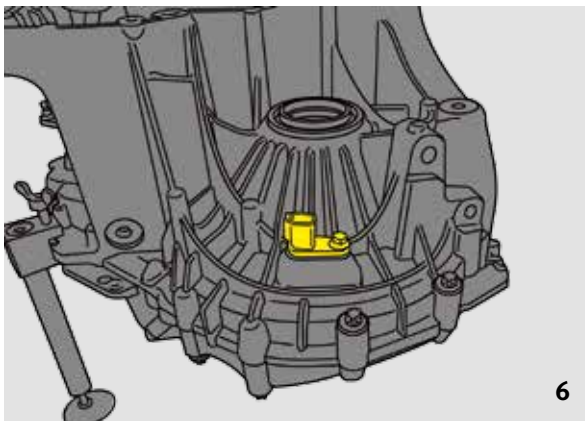

- Remove the speed sensor.

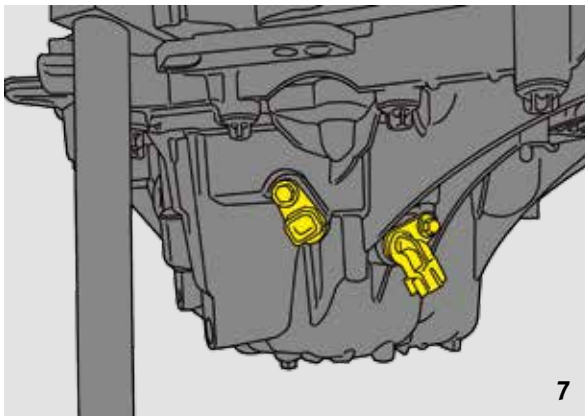

- Remove both rotational speed sensors.

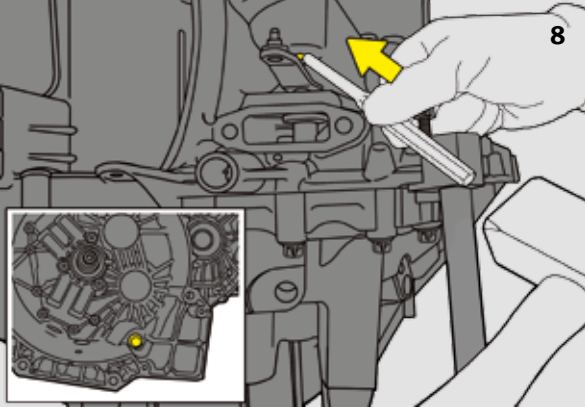

- Drive out the end cover for the mounting screw of the parking lock lever in direction of the arrow.

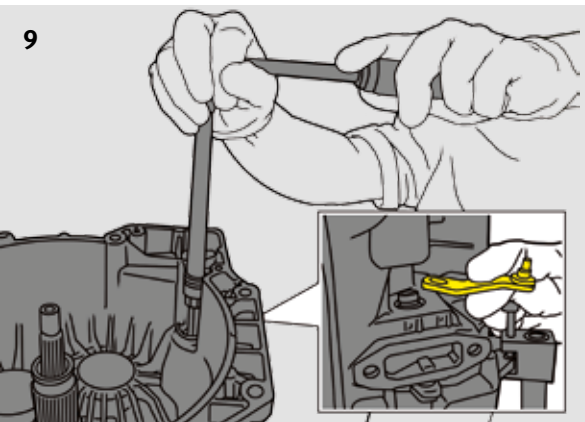

- Remove the parking lock lever screw.
- Remove the parking lock lever.

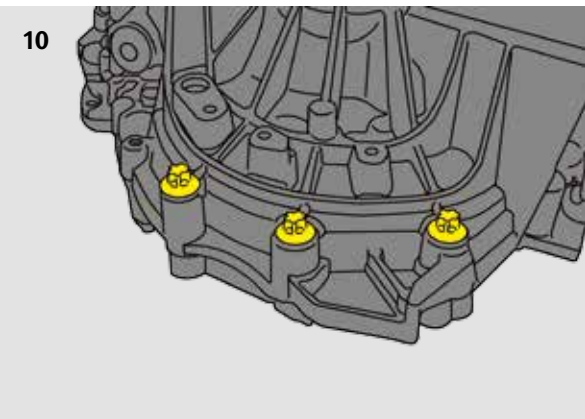

- Remove the housing screws on the differential side.

Note:

There are two or three screws on the differential depending on the variant.

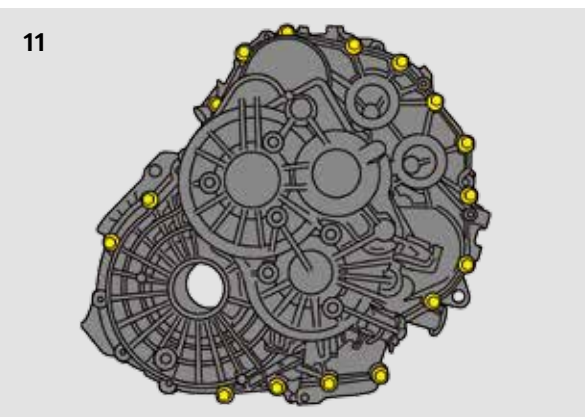

- Remove the housing screws.

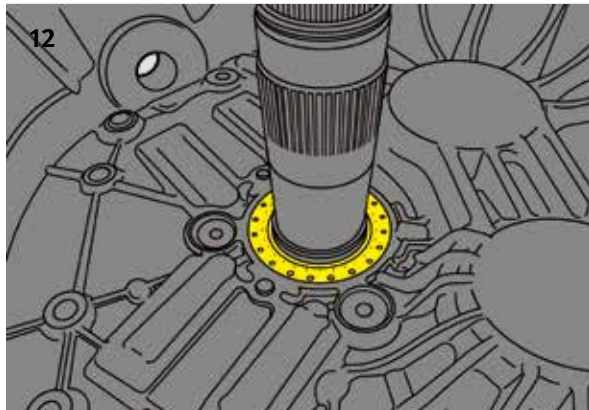

- Remove the drive shaft sealing ring.

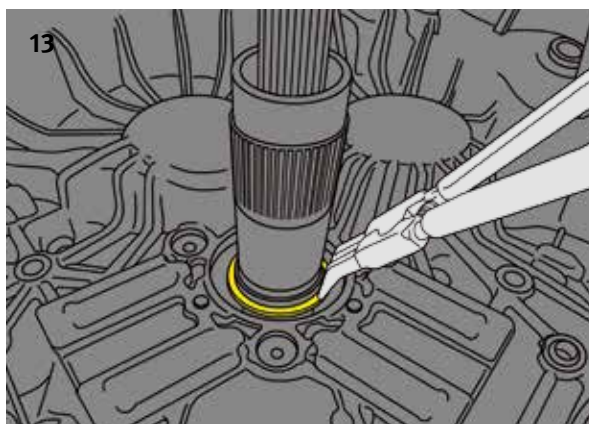

- Remove the drive shaft snap ring.

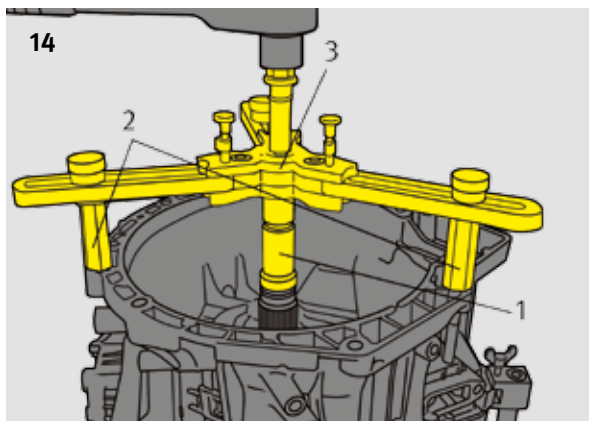

- Extract the clutch housing.

Note:

Position the thrust piece (1) from the LuK special tool kit for the Ford double clutch (400 0427 10) on the drive shaft. Mount the spacer (2) and puller with spindle and pressure piece (3) from the LuK basic tool kit (400 0418 10) for the dry double clutch.

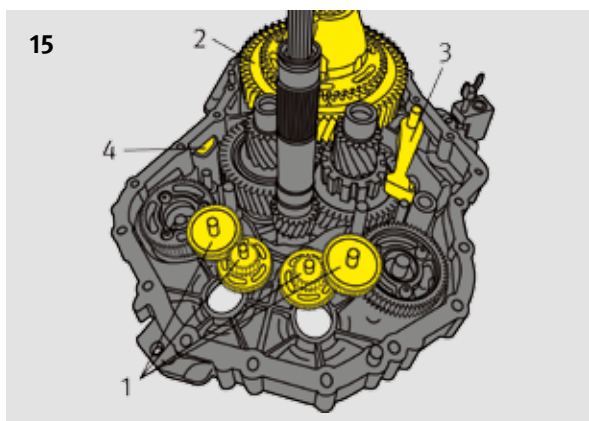

- Remove the large and small toothed gears (1) for the drive of the controller drums including the pins.
- Remove the differential (2).
- Disassemble the parking lock pawl and bolts (3).
- Remove the magnet (4).

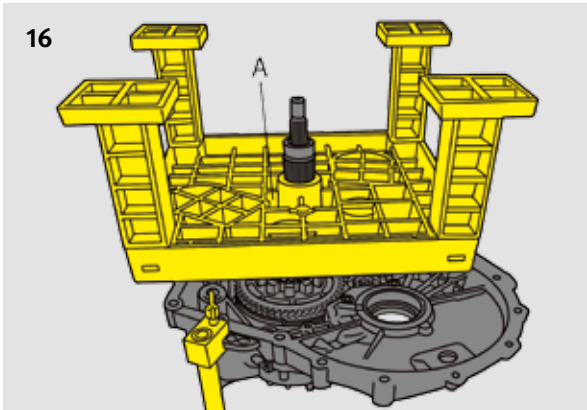

- Position the assembly table (A) from the special tool kit (400 0477 10) on the drive shaft.

Note:

Ensure that the controller drums and output shafts are correctly positioned in the special tool.

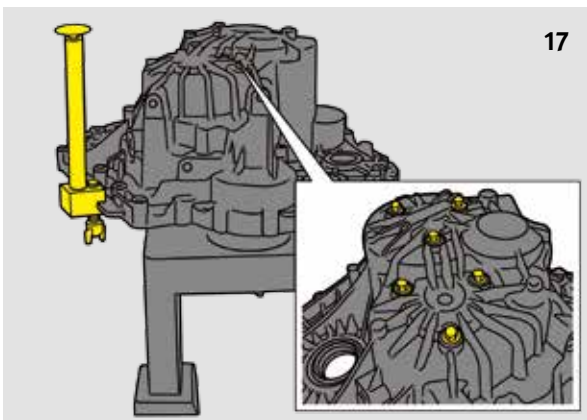

- Turn over the assembly table including the gearbox.
- Remove the stand.
- Remove the screws from the output shafts from the gearbox housing.

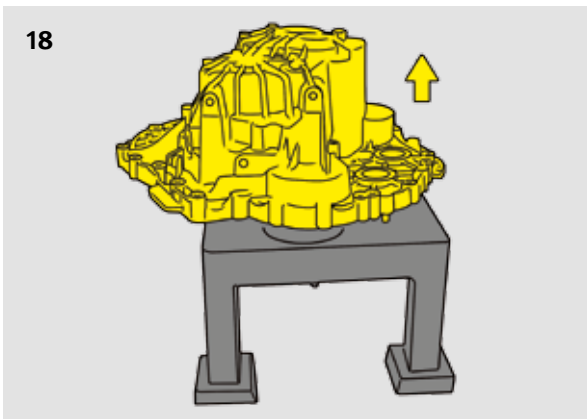

- Lift the gearbox housing in direction of arrow.

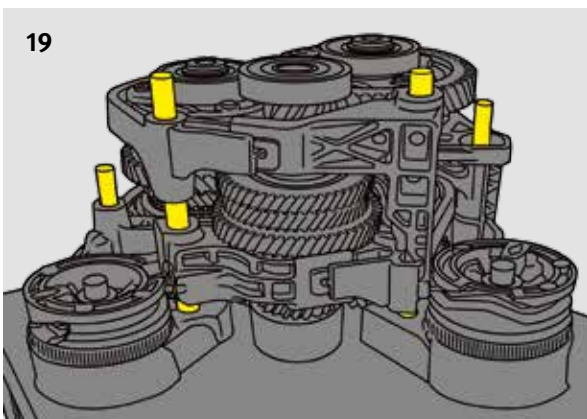

- Remove all four guide pins of the gear shift forks.

Note:

Take the different lengths of the guide pins into account.

Caution:

A plastic oil guide is used in some Ford DPS6 gearboxes for better lubrication of the drive shaft. This must be removed and then reused for the subsequent assembly.

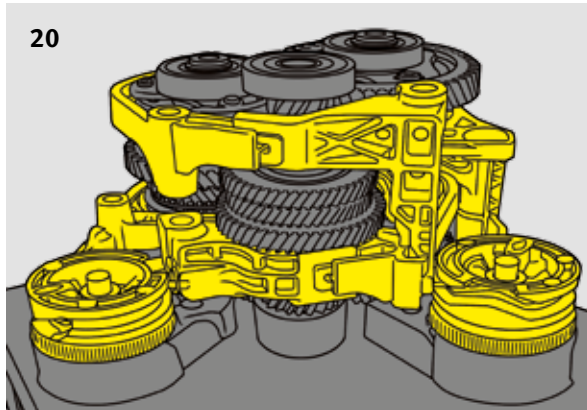

- Remove both controller drums.
- Disassemble the gear shift forks.

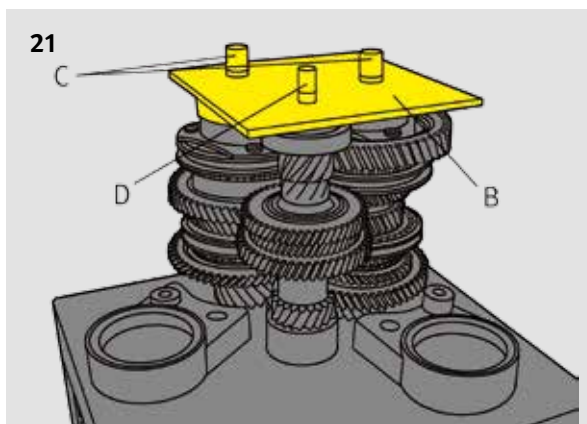

- Screw in the pins (C/D) from the special tool kit (400 0477 10) into the plate (B).
- Insert the mounted tools into the shaft cassettes.

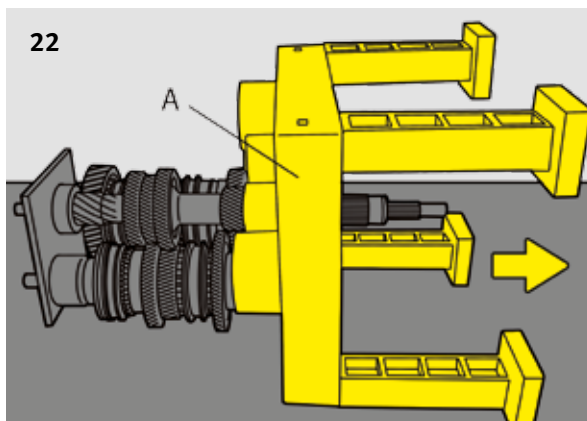

- Place the assembly table (A) and shaft cassettes on its side.
- Remove the assembly table (A) in direction of arrow.

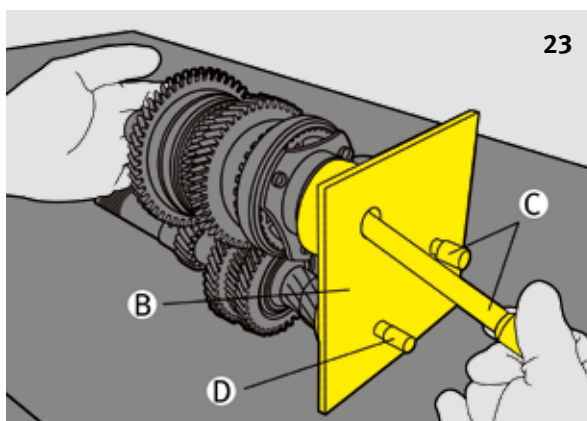

- Separate the shafts by unscrewing the guide pins (C/D) from the plate (B).

Caution:
Ensure that the shafts cannot be dropped.

24

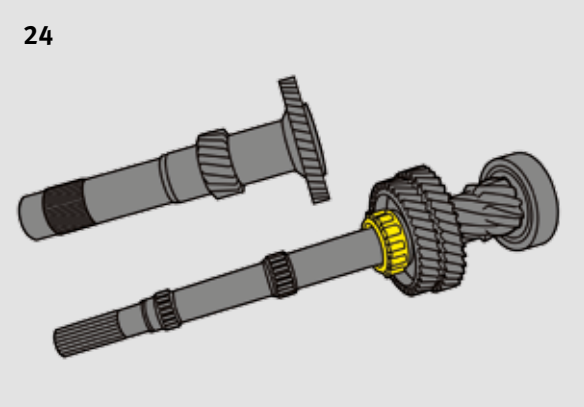

- Disassemble the drive shaft. To do so, remove the hollow shaft from the solid shaft.
- Remove the roller and cage assembly from the solid shaft.

Note:

Take the installation position of the roller and cage assembly into account.

25

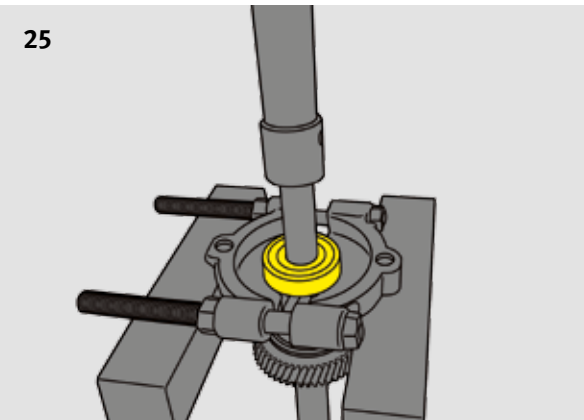

- Press off the gearbox-side bearing of the drive shaft.

Caution:

Ensure that the components cannot be dropped.

26

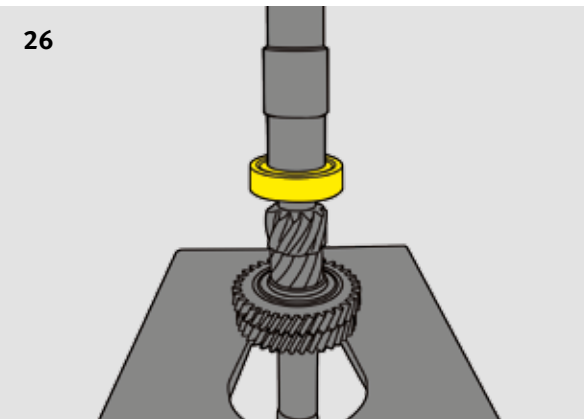

- Press-fit the gearbox-side bearing of the drive shaft.

Note:

Press-fit the bearing over the inner ring of the bearing with a suitable sleeve.

27

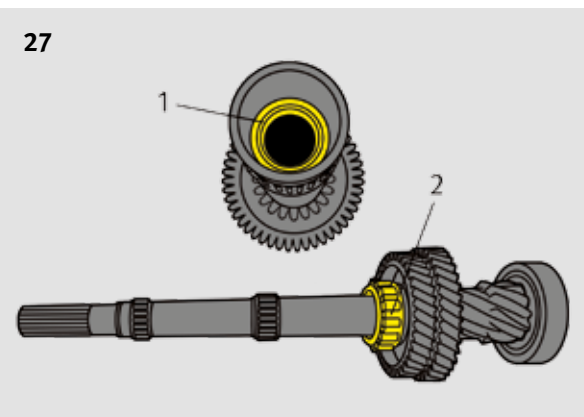

- Replace the sealing ring (1).
- Mount the roller and cage assembly (2).

Note:

The end of the roller and cage assembly with the large diameter must point in the direction of the toothed gears.

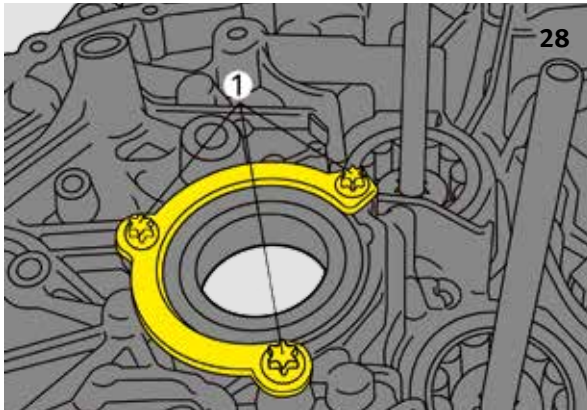

- Remove the screws (1) from the holding plate.
- Remove the holding plate.

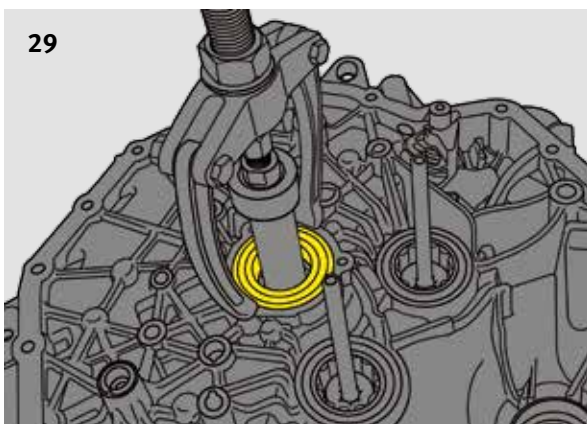

- Extract the bearing of the drive shaft.

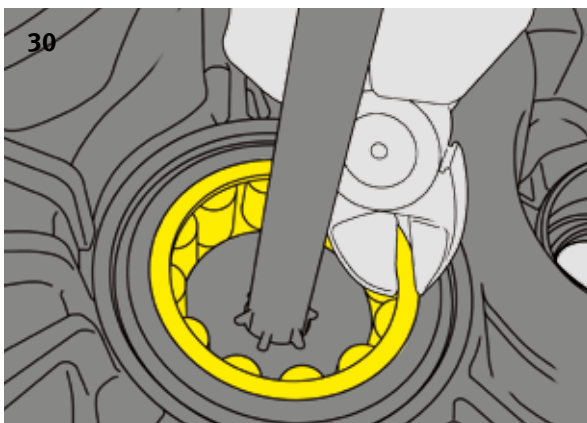

- Remove both engine-side output shaft bearing cages including the rolling element.

Note:
Cut the cages to remove them.

Caution:
Do not damage the oil guide.

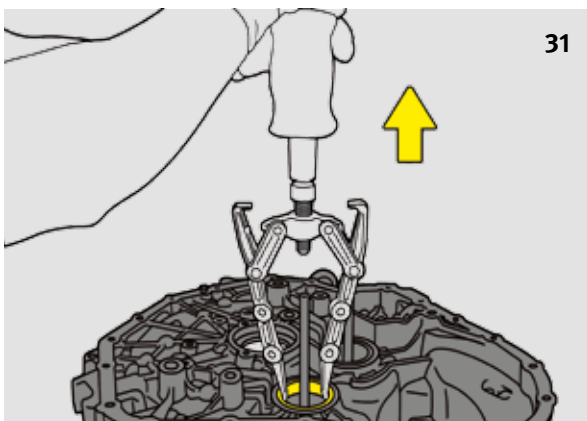

- Remove the outer ring of the bearing with the help of an inner puller and slide hammer.

Caution:
Do not damage the oil guide.

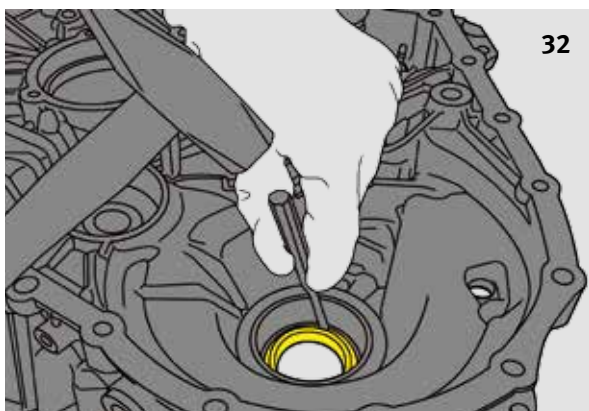

- Replace the flanged shaft sealing ring on the engine side.

Note:

Clean the sealing surface before installing the new sealing ring.

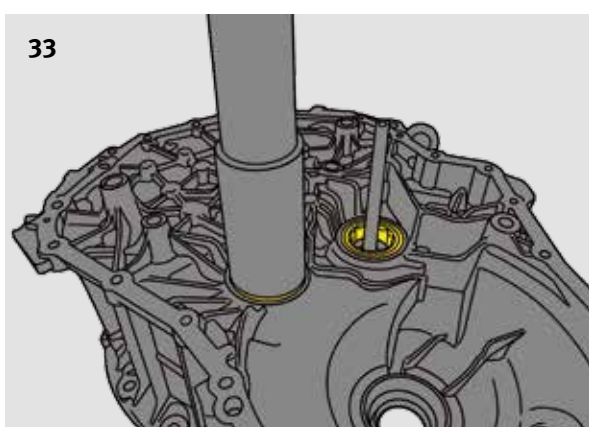

- Press-fit both engine-side output shaft bearings including the oil guide.

Caution:

Use a sufficiently high thrust piece to prevent damage to the oil guide.

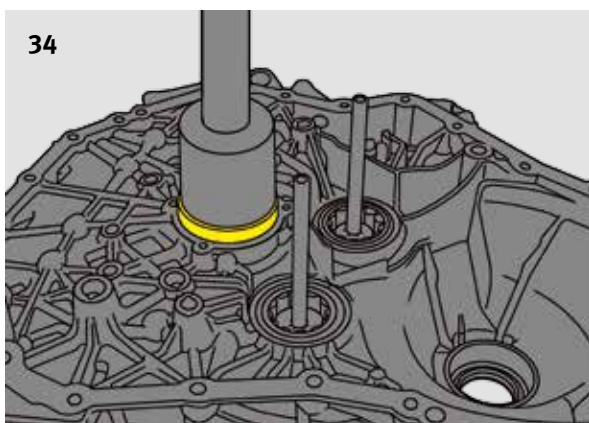

- Press-fit the engine-side drive shaft bearing.

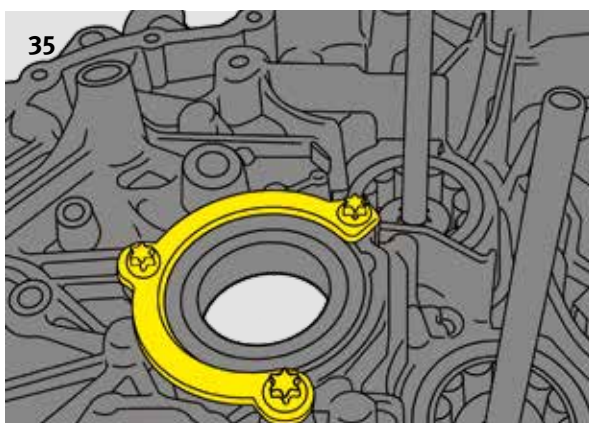

- Mount the holding plate.

Tightening torque of the holding plate screws:
11 Nm

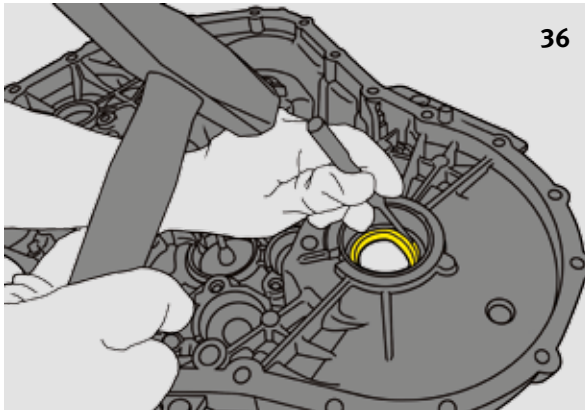

36

- Replace the flanged shaft sealing ring on the gearbox side.

Note:

Clean the sealing surface before installing the new sealing ring.

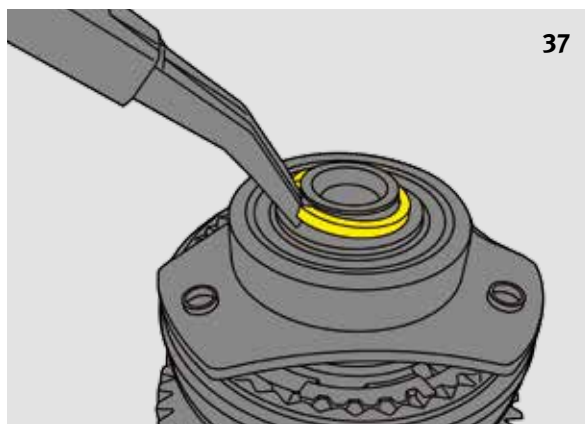

37

- Remove the circlips of the two output shafts 1+2.

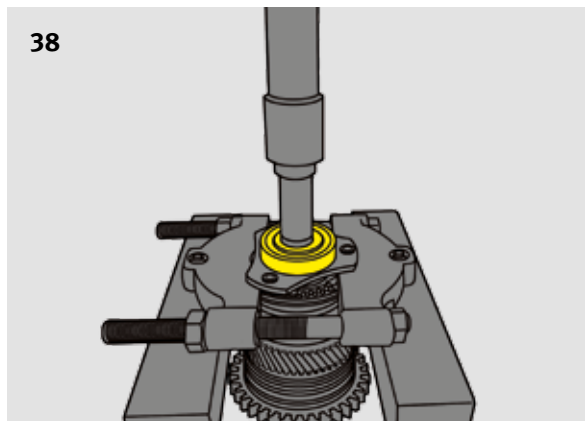

38

- Press off the output shaft 1 bearing on the gearbox side.

Caution:

Ensure that the components cannot be dropped.

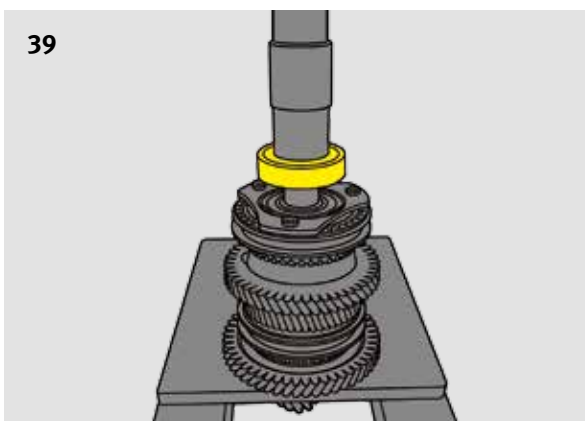

39

- Press-fit the output shaft 1 bearing on the gearbox side.

Note:

The heel in the outer ring of the bearing must point towards the holding plate.

Caution:

Support the shaft cassette when pressfitting it onto the parking lock gear.

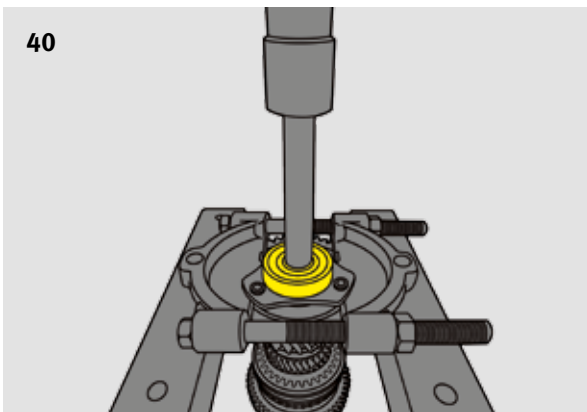

40

- Press off the output shaft 2 bearing on the gearbox side.

Caution:

Ensure that the components cannot be dropped.

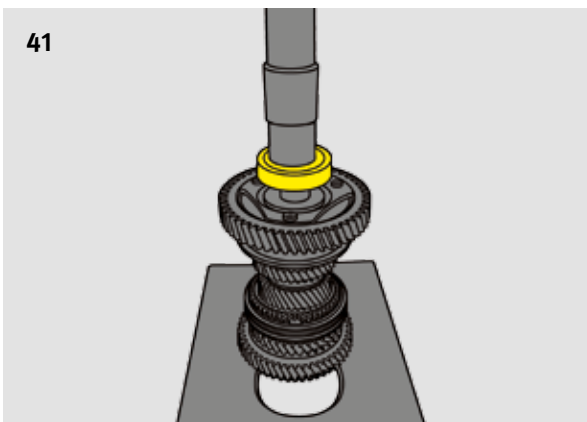

41

- Press-fit the output shaft 2 bearing on the gearbox side.

Note:

The heel in the outer ring of the bearing must point towards the holding plate.

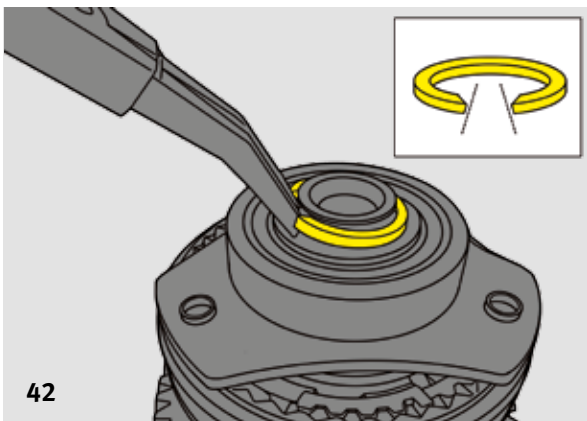

42

- Mount the circlips of the two drive shafts 1+2.

Note:

Observe the installation position of the circlips.

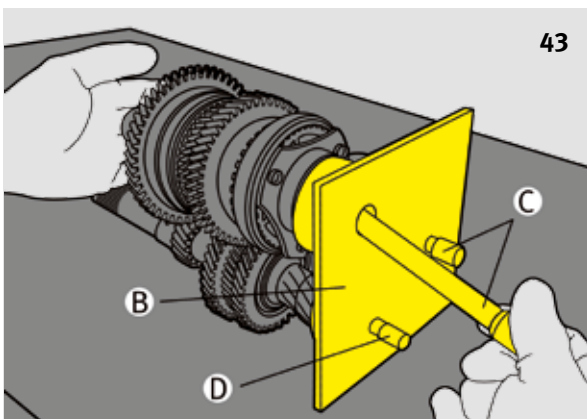

43

- Mount the drive and output shafts with the guide pin (C/D) on the plate (B).

Caution:

Ensure that the shafts cannot be dropped.

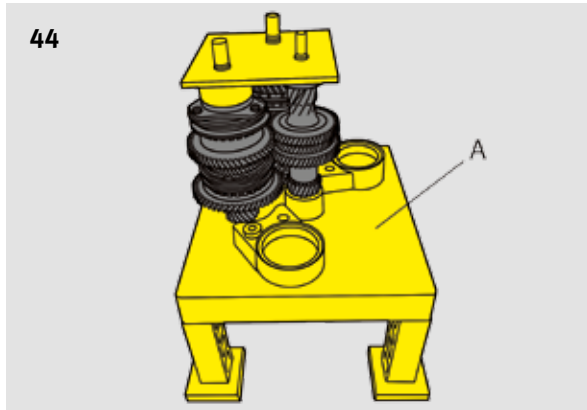

- Position the shaft cassettes on the assembly table (A).
- Remove the plate including the pins from the drive and output shafts.

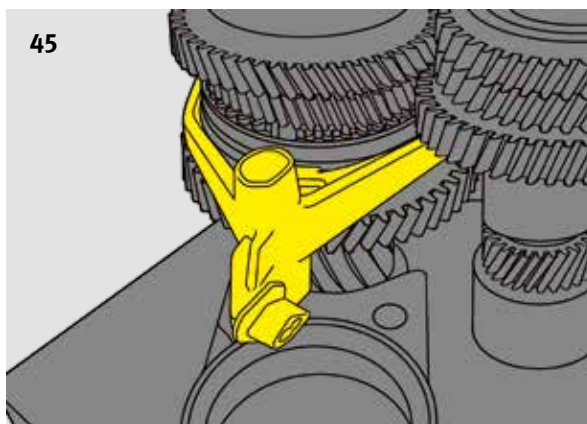

- Mount the gear shift rod and the gear shift fork for fourth gear and reverse gear.

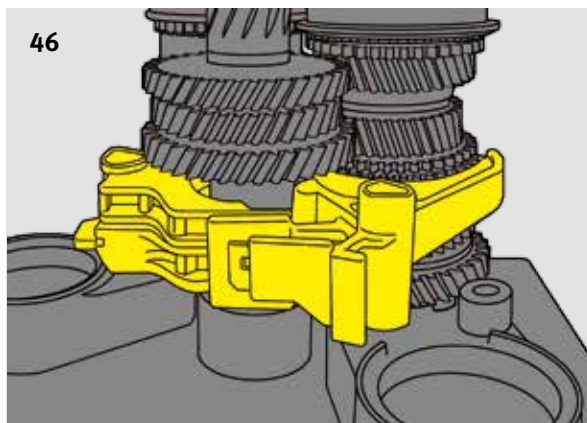

- Mount the gear shift forks for second and sixth gears together.

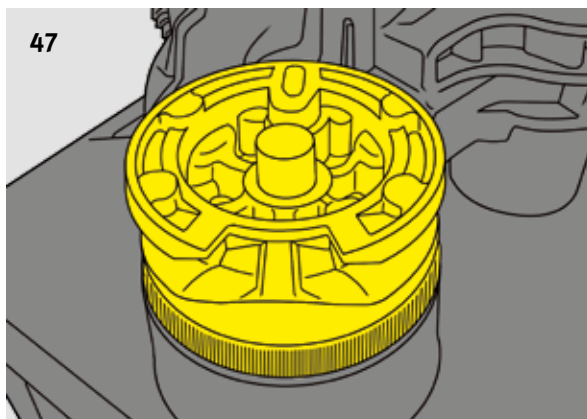

- Mount controller drum 1 and the pin.

48

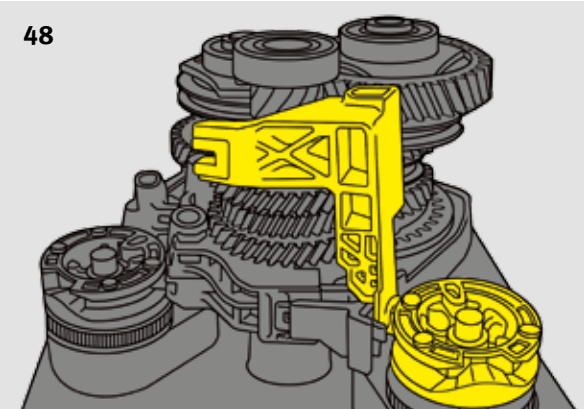

- Mount the gear shift rod for third gear, controller drum 2 and the pin.

49

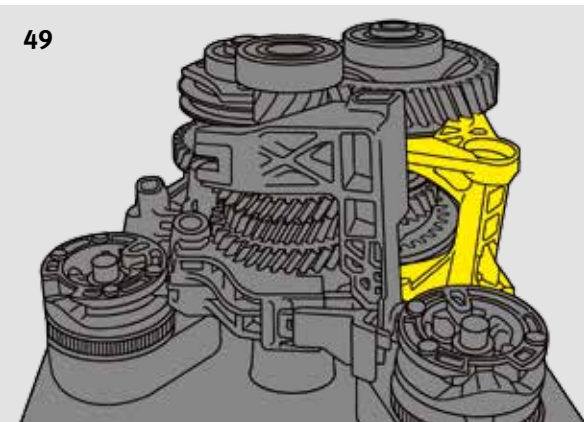

- Mount the gear shift fork for first and fifth gear.

50

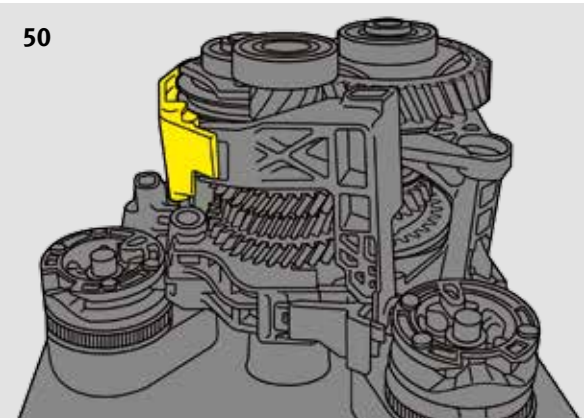

- Mount the gear shift fork for third gear.

51

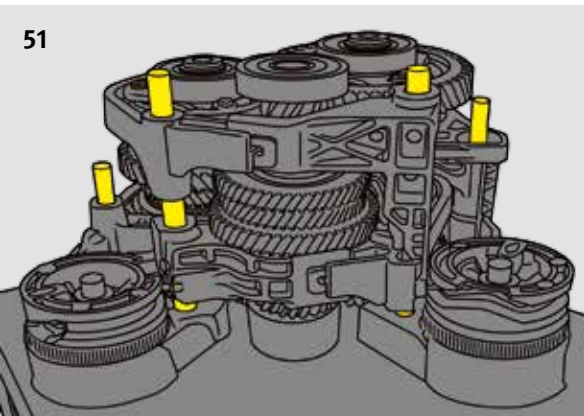

- Mount all four guide pins of the gear shift forks.

Note:

Take the different lengths of the guide pins into account.

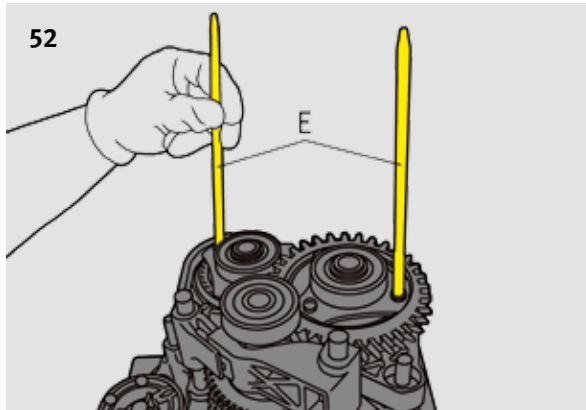

- Screw in the guide pins (E).

Note:

A plastic oil guide is used for some Ford DPS6 gearboxes for better lubrication of the drive shaft. If an oil guide has been disassembled at this installation location, it must be reinserted during this work step.

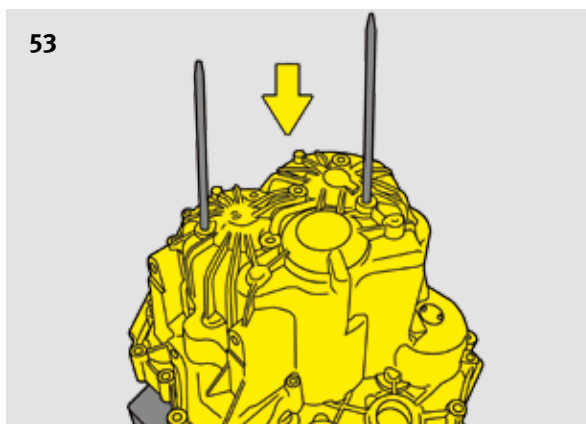

- Attach the gearbox housing.

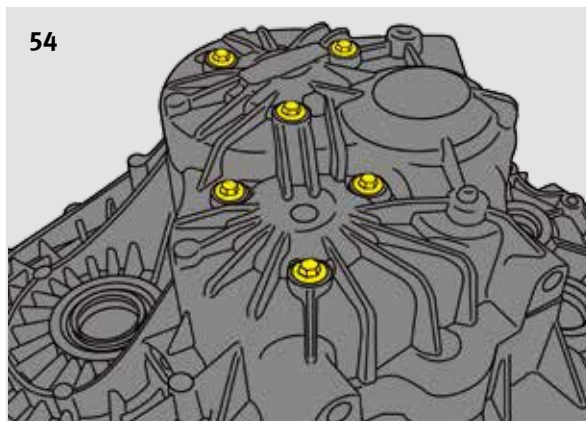

- Remove the guide pins.
- Screw the holding plates of the output shafts with the gearbox housing into place in two steps.
Tightening torque of the holding plate screws:
Step 1: 10 Nm
Step 2: 32 Nm

Note:

To facilitate the installation of the screws, pull the holding plates upwards using the guide pins.

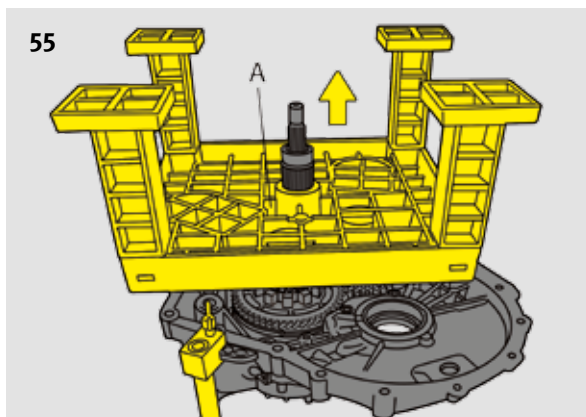

- Mount the stand from the LuK basic tool kit for dry double clutches.
- Turn over the gearbox half with assembly table (A).
- Lift up the assembly table (A) to remove it.

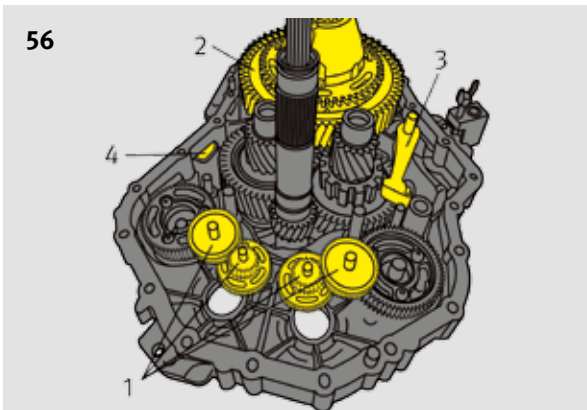

- Insert the large and small toothed gears (1) for the drive of the controller drums including the pins.
- Insert the differential (2).
- Mount the parking lock pawl and pin (3).
- Insert the magnet (4).



- Replace the rotary shaft seal of the parking lock lever.

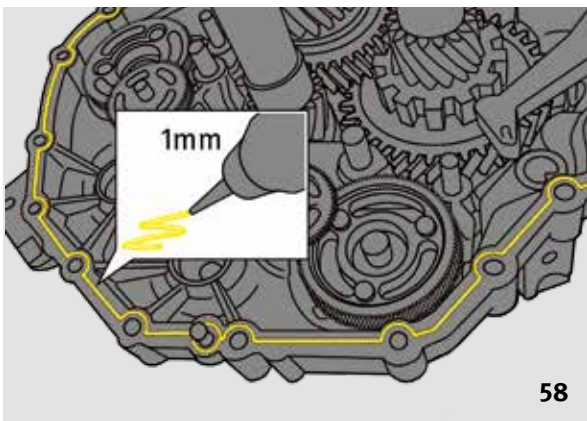

- Apply sealant evenly on one side of the gearbox as shown.

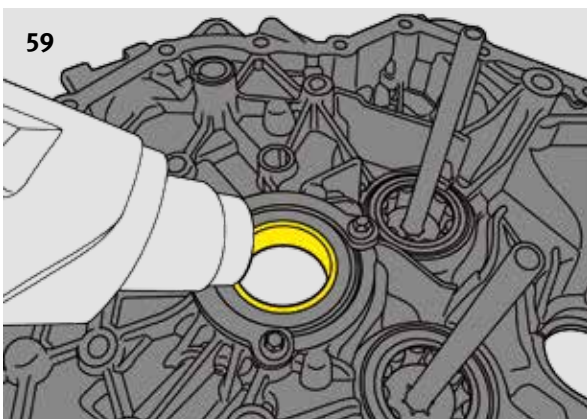

- Heat the engine-side bearing inner ring of the drive shaft to facilitate mounting of the gearbox housing.

Caution:
Do not damage the seal while heating!

- Attach the gearbox housing.

Note:
Take the installation position of the parking lock lever into account.

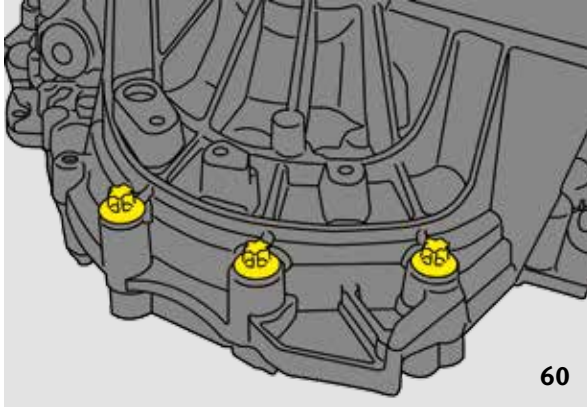

- Tighten the housing screws on the differential.
Tightening torque of the housing screws: 27 Nm

Note:

There are two or three screws on the differential depending on the variant.

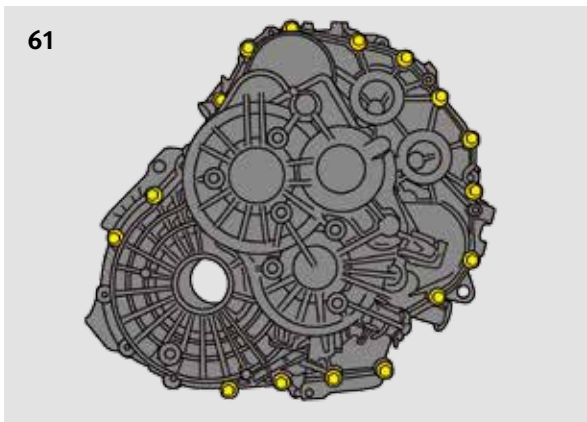

- Tighten the housing screws.
Tightening torque of the housing screws: 27 Nm

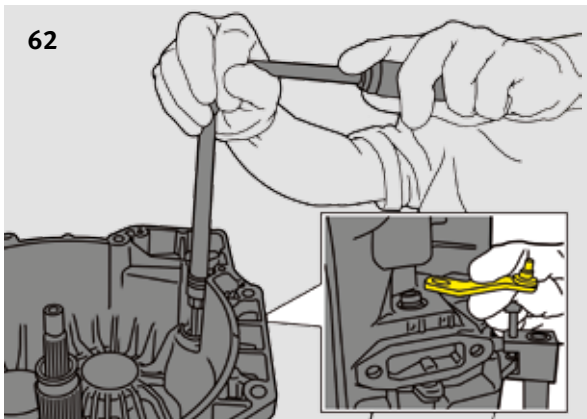

- Mount the parking lock lever.
Tightening torque of the parking lock lever screw: 26 Nm
- Insert the end cover.

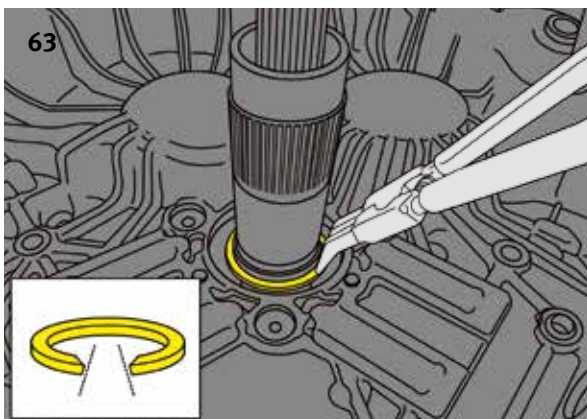

- Mount the drive shaft circlip.

Note:

Take the installation position of the circlip into account.

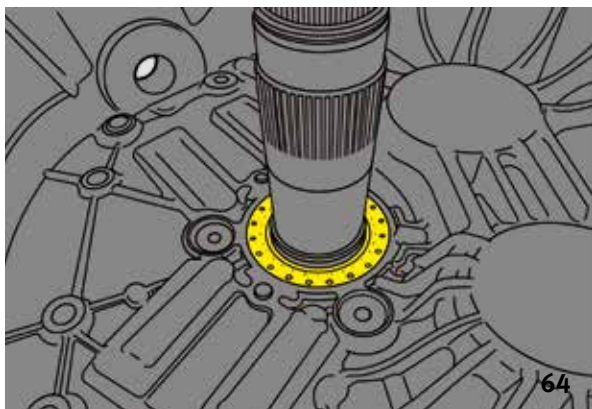

- Insert the sealing ring.

Note:

The bearing seat of the hollow shaft must be cleaned and in faultless condition!

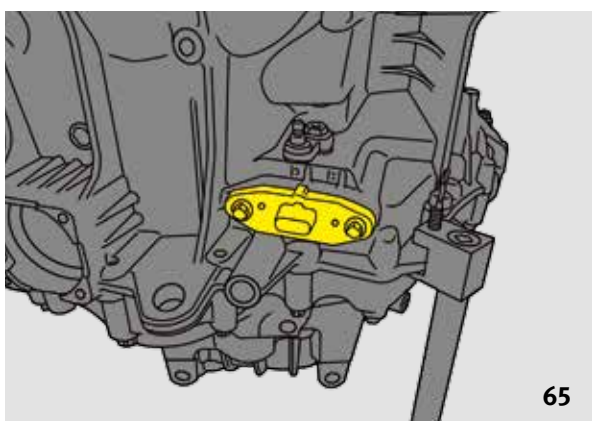

- Replace the parking lock switch seal.
- Mount the parking lock switch.
Tightening torque of the screw for the parking lock switch: 10 Nm

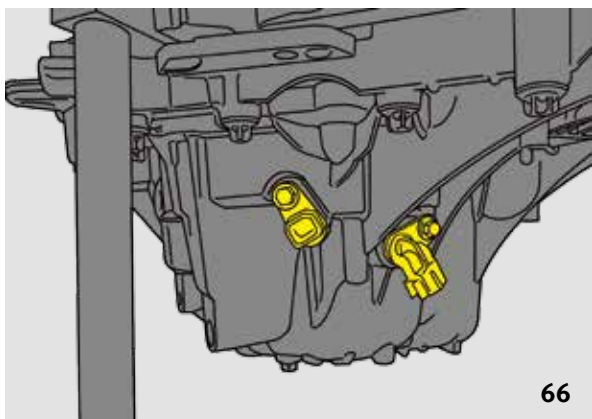

- Replace the o-rings of the two rotational speed sensors.
- Mount the rotational speed sensors.
Tightening torque of the rotational speed sensors screws: 10 Nm

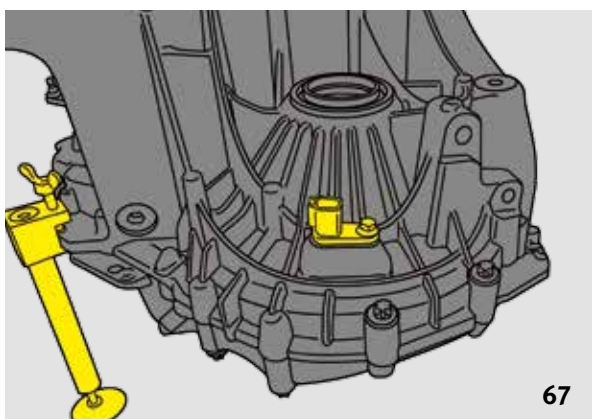

- Replace the o-ring for speed sensor.
- Mount the speed sensor.
Tightening torque of the screw for the speed sensor: 10 Nm
- Remove the stand.

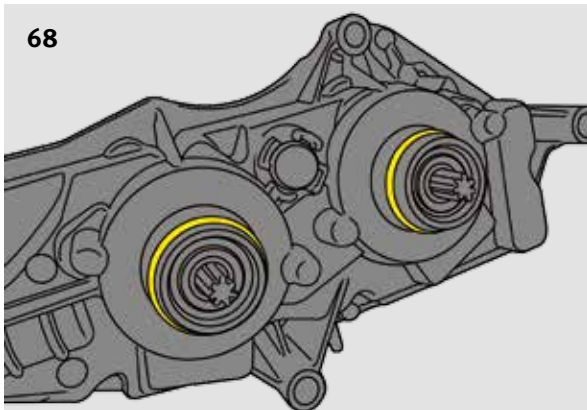

- Replace the two o-rings of the mechatronics.

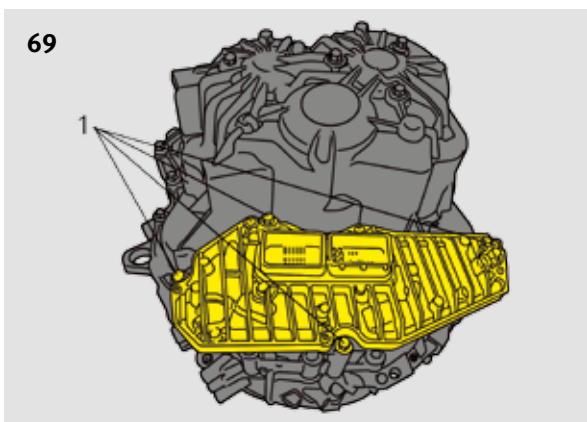

- Mount the mechatronics.
Tightening torque of the mechatronics (1) screws:
27 Nm



- Mount the clutch, lever actuators and guiding sleeve as described in the LuK RepSet 2CT repair manual (999 6006 570) for the Ford DPS6 gearbox.
- Install the gearbox in the vehicle in accordance with the vehicle manufacturer specifications.
- Replace the o-rings of the oil filler plug.
- Fill the empty gearbox with 1.8 l of gearbox oil.
- Mount the oil filler plug.
Tightening torque of the oil filler plug: 43 Nm

More garage knowledge:
www.rexpert.com