



LR-HVAC-230-S

## Room Thermostat LR-HVAC-230-S Application and Set-Up Guide

# Table of Contents

<b>About this document</b> .....	4
Before you start .....	4
Document use/request to the reader .....	5
<b>Summary</b> .....	5
Applications .....	5
Functions .....	6
Integration via Modbus .....	6
Compatible Accessory Devices by Siemens .....	7
<b>Functions</b> .....	9
Temperature control .....	9
Operating modes .....	10
Different ways to influence the operating mode .....	11
Room temperature setpoint .....	12
Description .....	12
Setting and adjusting setpoints .....	13
Applications overview .....	14
Additional functions .....	15
Control sequences .....	18
Sequences overview (setting via parameter P01) .....	18
2-pipe fan coil unit .....	19
2-pipe fan coil unit with electric heater .....	20
4-pipe fan coil unit .....	22
Chilled/heated ceiling and radiator applications .....	23
Compressor applications .....	23
Setpoints and sequences .....	24
Control outputs .....	26
Overview .....	26
Control outputs configuration (setting via DIP switches) .....	27
Fan control .....	28

## Table of Contents *(continued)*

### Functions *(continued)*

Multifunctional input, digital input.....	31
Handling faults.....	32
Modbus RTU mode.....	32
Control parameters.....	34
Parameter setting via local HMI.....	34
Parameters of the “Service level” .....	35
Parameters of the “Expert level with diagnostics and test” .....	36

### Handling ..... 39

Mounting and installation.....	39
Commissioning.....	40
Operation .....	41

### Connection..... 43

Connection terminals.....	43
Connection diagrams .....	44

### Mechanical design ..... 45

General.....	45
--------------	----

### Dimensions ..... 47

### Technical data ..... 48

## About This Document

### Before you start

#### Document use/request to the reader

Before using our products, it is important that you read the documents supplied with or ordered at the same time as the products (equipment, applications, tools, etc.) carefully and in full.

We assume that persons using our products and documents are authorized and trained appropriately and have the technical knowledge required to use our products as intended.

## Summary

### Applications

#### Fan coil units via ON/OFF outputs:

- 2-pipe system\*
- 2-pipe system with electric heater
- 4-pipe system

#### Chilled/heated ceilings (or radiators) via ON/OFF outputs:

- Chilled/heated ceiling\*
- Chilled/heated ceiling with electric heater
- Chilled/heated ceiling and radiator/floor heating

#### Compressors: via ON/OFF control

- 1-stage compressors in DX type equipment
- 1-stage compressors in DX type equipment with electric heater

#### The room thermostats are delivered with a fixed set of applications.

The relevant application is selected and activated during commissioning using the Local DIP switch and HMI

### Features

- Operating modes: Comfort, Economy (Energy Saving) and Protection (Deep Energy Saving)
- ON/OFF or 3-position control outputs (relay)
- Output for 3-speed or 1-speed fan
- Automatic or manual heating/cooling changeover
- Backlit display
- 230 V~ operating voltage

\* Note: with both ON/OFF or 3-position modulating control output.

*continued next page*

## Summary *(continued)*

### Functions

- Room temperature control via built-in temperature sensor or external room temperature/return air temperature sensor
- Changeover between heating and cooling mode (automatic via local sensor or manually)
- Selection of applications via DIP switches and HMI.
- Select operating mode via operating mode button on the thermostat
- 1- or 3-speed fan control (automatically or manually)
- Display of current room temperature or setpoint in °C and/or °F
- Minimum and maximum limitation of room temperature setpoint
- Button lock (automatically or manually)
- 2 multifunctional inputs, freely selectable for:
  - Operating mode switchover contact (keycard, window contact, etc.)
  - Sensor for automatic heating/cooling changeover
  - External room temperature or return air temperature sensor
  - Dew point sensor
  - Electric heater enable
  - Fault input
  - Monitor input for temperature sensor or switch state
- Advanced fan control function, e.g. fan kick, fan start, selectable fan operation (enable, disable or depending on heating or cooling mode)
- “Purge” function together with 2-port valve in a 2-pipe changeover system
- Reminder to clean fan filters
- Floor heating temperature limitation
- Reload factory settings for commissioning and control parameters
- RS 485 terminals MUX,  $\overline{\text{MUX}}$  and COM for communication with Lutron® compatible devices

### Integration via Modbus















The LR-HVAC-230-S is a communicating thermostat with Modbus open protocol on RTU (Remote Terminal Unit) mode enabling easy integration into Lutron® myRoom™ and HomeWorks® QS solutions.

The following functions are available:

- Central controls of room operating modes, setpoints, fan speed and fan mode
- Remote monitoring e.g. operating mode, control outputs, temperature sensor or switch, etc.
- Alarming, e.g. external fault contact, condensation, clean filter, etc.

Engineering and commissioning can be done using local DIP switches/HMI

**Summary** *(continued)***Compatible Accessory Devices by Siemens**

Description		Siemens product no.	Siemens data sheet
Cable temperature sensor or changeover sensor, cable length 2.5 m		QAH11.1	1840
Room temperature sensor		QAA32	1747
Cable temperature sensor (under floor heating), cable length 4 m		QAP1030/UFH	1854
Condensation monitor		QXA2601 / QXA2602 / QXA2603 / AQX2604	3302
<b>ON/OFF actuators:</b>			
Electromotoric ON/OFF actuator		SFA21...	4863
Electromotoric ON/OFF valve and actuator (only available in AP, UAE, SA and IN)		MVI.../MXI...	4867
Zone valve actuator (only available in AP, UAE, SA and IN)		SUA...	4832
Thermal actuator (for radiator valves)		STA23...	4884
Thermal actuator (for small valves 2.5 mm)		STP23...	4884
<b>3-position actuators:</b>			
Electrical actuator, 3-position (for radiator valves)		SSA31...	4893
Electrical actuator, 3-position (for 2- and 3-port valves/V...P45)		SSC31...	4895
Electrical actuator, 3-position (for small valves 2.5 mm)		SSP31...	4864
Electrical actuator, 3-position (for small valves 5.5 mm)		SSB31...	4891
Electrical actuator, 3-position (for small valves 5.5 mm)		SSD31...	4861
Electromotoric actuator, 3-position (for small valves 5.5 mm)		SQS35...	4573

*continued next page*

**Summary** *(continued)***Compatible Accessory Devices by Siemens** *(continued)*

Description	Siemens product no. /SSN	Siemens data sheet
Changeover mounting kit sensor, cable length 2.5 m (50 pcs/package) 	ARG86.3	N3009
Plastic mounting spacer for flush mount thermostats to increase the headroom in the conduit box by 10 mm 	ARG70.3	N3009
Conduit box for flush mounted thermostat 	ARG71 / S55770-T137	N3009



## Functions

### Temperature control

#### General note: Parameters

Setting of the control parameters (P01, etc., mentioned throughout the document) is described on page 34.

#### Temperature control

The thermostat acquires the room temperature via built-in sensor, external room temperature sensor, or external return air temperature sensor, and maintains the setpoint by delivering actuator control commands to heating and/or cooling equipment. The following control outputs are available:

- ON/OFF control (2-position)
- Modulating PI/P control with 3-position control output (only for 2-pipe applications)

The switching differential or proportional band is 2 K for heating mode and 1 K for cooling mode (adjustable via parameters P30 and P31).

The integral action time for modulating PI (Proportional and Integral) control is 5 minutes (adjustable via parameter P35).





#### Display

The display shows the acquired room temperature or the Comfort setpoint, selectable via parameter P06. The factory setting displays the current room temperature.

Use parameter P04 to display the room temperature or setpoint in °F rather than °C as needed.

#### Heating and Cooling

The acquired room temperature (internal or external sensor) is also available as information in the Lutron® system.

- With automatic changeover or continuous heating/cooling, symbols   indicate that the system currently heats or cools (heating or cooling output is activated).
- With manual changeover (P01 = 2), symbols   indicate that the system currently operates in heating or cooling mode. Thus, the symbols are displayed even when the thermostat operates in the neutral zone.

#### Concurrent display of °C and °F

Concurrent display of the current temperature or setpoint in °C and °F (parameter P07 = 1) is possible on the thermostat.

*Continued on next page*

## Functions *(continued)*

### Operating modes

The thermostat's operating mode can be influenced in different ways. e.g. operating mode button, switch over contact, etc. Specific heating and cooling setpoints are assigned to each operating mode.

The following operating modes are available:

- **Comfort** ☀ :

In Comfort mode, the thermostat maintains the Comfort setpoint. This setpoint can be defined via parameters P7, P8 and P9.

Also, it can be locally adjusted via the +/- buttons or remotely via system programming.

In Comfort mode, the fan can be set to automatic or manual fan speed: Low, medium or high.

- **Economy** ☹ :

A preset setpoint in Economy mode can be defined via parameters P11 and P12. The thermostat switches to Economy mode when:

- The operating mode button is pressed (only possible if parameter P02 is set to 2)
- Economy mode is selected via system programming.
- An operating mode switchover contact (e.g. keycard contact presence detector, window contact) is active. The contact can be connected to multifunctional input X1, X2. Set parameter P38/P40 to 3 (P02 is irrelevant) \*

- **Protection** ⚡:

In Protection mode, the system is:

- Protected against frost (factory setting 8 °C, can be disabled or changed via P65)
- Protected against overheating (factory setting OFF, can be enabled or changed via P66)

No other operating mode can be selected locally if Protection mode is commanded via the system programming.

⚡ is displayed.

\* Operating mode switchover: Only one input source must be used, either local input X1 /X2 or the system programming. User operations are ineffective and "OFF" is displayed if the operating mode switchover contact is active.

## Functions *(continued)*

### Different ways to influence the operating mode

#### Priority of operating mode interventions

The operating mode can be influenced by different interventions. The table below shows the priorities of different interventions. (i.e. lower number = higher priority)



Priority	Description	Remark
①	Commissioning	In parameter setting mode (highest priority), you can always command an operating mode independent of all other settings or intervention via the system programming and local input.
②	Operating mode switchover contact	If the contact is closed, the operating mode changes to Economy. This overrides the operating mode on the thermostat.
③	Operating mode via system programming	The operating mode can be changed via system programming. <b>Note:</b> Operating mode button is disabled if Protection mode is commanded via system programming.
④	Operating mode button	The user can switch the operating mode via the operating mode button.

**Note:** Higher priority commands can override the lower priority command. If operating mode is set via system programming, the unit will indicate by flashing “OFF” when Operating Mode button pressed by user.

#### Availability of Economy mode

The operating mode can be selected locally via the operating mode button.

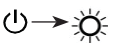
The behavior of the operating mode button (user profile) can be defined via parameter P02, factory setting is P02 = 1.

P02	Description	Remark
1		<ul style="list-style-type: none"> <li>Switching manually between 2 modes, Economy is not available (factory setting).</li> <li>Suited for hotel guest rooms or commercial buildings.</li> </ul>
2		<ul style="list-style-type: none"> <li>Switching manually between 3 modes.</li> <li>Suited for homes and rooms where manual switching to Economy mode is desired.</li> </ul>

#### Operating mode switchover contact (window contact)

The thermostat can be forced into Economy mode (e.g. when a window is opened, when a presence detector signals “no one present”, when the keycard of a hotel room is withdrawn, etc.). The contact can be connected to multifunctional input X1, X2. Set parameter P38, P40 to 3.

**Note:** Only one input source must be used, either local input X1/X2 or system programming.

User operations are ineffective and “OFF” is displayed if the operating mode switch-over contact is active.

## Functions *(continued)*

### Room temperature setpoint

#### Description

#### Comfort mode

The default setting for the Comfort basic setpoint is 21 °C and can be changed via parameter P08 or system programming. The last intervention/input that was used will determine the setting.

The Comfort setpoint can be adjusted via the +/- buttons, or via the system programming. The last intervention/input that was used will determine the setting.

#### Temporary setpoint

If the "Temporary setpoint" function is enabled via parameter P69, the Comfort setpoint is set back to the default Comfort setpoint stored in P08 when the operating mode changes.

#### Setpoint limitation

For energy saving purposes, the setpoint setting range can be limited to minimum (P09) and maximum (P10) temperatures.

#### P09 < P10:

- If the minimum limit P09 is set lower than the maximum limit P10, both heating and cooling are adjustable between these 2 limits.

#### P09 ≥ P10:

- For heating or cooling applications (e.g. 2-stage):
  - The setting range in cooling mode is from P09...P10
  - The setting range in heating mode is from P09...P10 °C
- For heating and cooling applications (e.g. 4-pipe):
  - The cooling and heating setpoints are adjustable
  - The setting range in cooling mode is from P09...40 °C in place of 5...40 °C
  - The setting range in heating mode is from 5...P10 °C in place of 5...40 °C

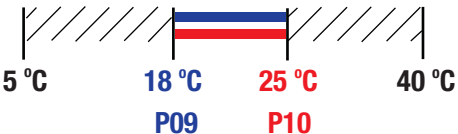
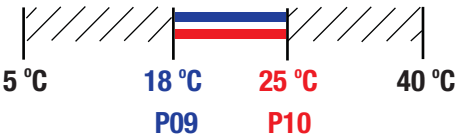
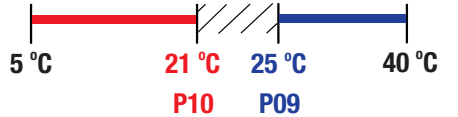
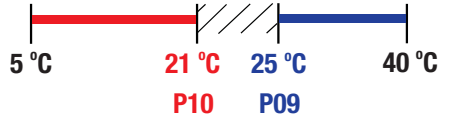
Examples	2-pipe heating OR cooling	4-pipe heating AND cooling
P09 < P10	 <p>Cooling setpoint adjustable 18...25 °C Heating setpoint adjustable 18...25 °C</p>	 <p>Cooling setpoint adjustable 18...25 °C Heating setpoint adjustable 5...25 °C</p>
P09 ≥ P10	 <p>Cooling setpoint adjustable 25...40 °C Heating setpoint adjustable 5...21 °C</p>	 <p>Cooling setpoint adjustable 25...40 °C Heating setpoint adjustable 5...21 °C</p>

#### Economy mode

Use control parameters P11 and P12 to adjust the Economy mode setpoints. The heating setpoint is factory-set to 15 °C, and the cooling setpoint to 30 °C.

*Continued on next page*

## Functions *(continued)*

### Room temperature setpoint *(continued)*

#### Description *(continued)*

#### Protection mode

Use control parameters P65 and P66 to adjust the Protection mode setpoints.  
The heating setpoint is factory-set to 8 °C (frost protection) and to OFF for cooling.

**Notice:** If a setpoint (Economy or Protection) is set to OFF, the thermostat does not control the room temperature in the corresponding mode (heating or cooling).  
This means no protective heating or cooling function and thus risk of frost in heating mode or risk of over-temperature in cooling mode!

The Economy setpoints are accessible at the service level (P11, P12); the Protection setpoints at the expert level (P65, P66).

### Setting and adjusting setpoints

#### General notes:

- Setting the Comfort basic setpoint will reset the runtime Comfort setpoint to the basic setpoint.

#### Notes on setpoint adjustment

- The resulting (current) setpoint heating and cooling is limited by the Protection setpoint; if Protection setpoint is OFF, then minimum 5 °C and maximum 40 °C are used.
- The resulting setpoints for cooling and heating of the same operating mode have a minimum distance of 0.5 K between them.

*Continued on next page*

## Functions *(continued)*

### Applications overview







The thermostat supports the following applications, which can be configured using the DIP switches inside the front panel of the unit.

If all DIP switches are set to OFF display will show “None” The DIP switches must be used to select an application.

The LR-HVAC-230-S offers the applications printed in bold text (basic applications).

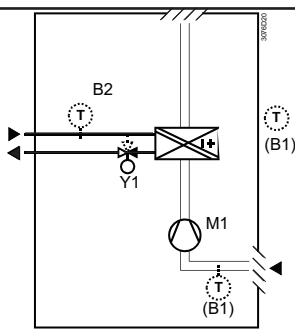
For universal applications (chilled ceiling, etc.), refer to section *Chilled/heated ceiling and radiator applications*.

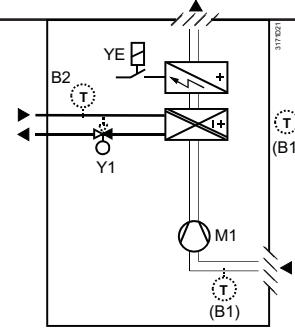
For compressor applications, refer to section *Compressor applications*.

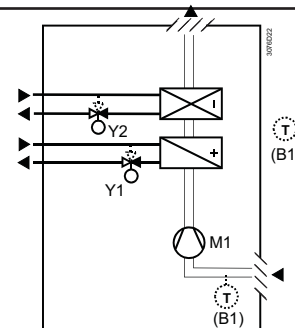
Application and output signal	DIP switches	Diagram
<b>Remote configuration</b> Not available (factory setting) Display shows “None”		
<b>Heating or cooling</b> <ul style="list-style-type: none"> <li>• <b>2-pipe fan coil unit</b> ON/OFF (heating or cooling)</li> <li>• Chilled/heated ceiling ON/OFF (heating or cooling)</li> <li>• 1-stage compressor ON/OFF (heating or cooling)</li> </ul>		
<ul style="list-style-type: none"> <li>• <b>2-pipe fan coil unit</b> 3-position (heating or cooling)</li> <li>• Chilled/heated ceiling 3-position (heating or cooling)</li> </ul>		
<b>Heating or cooling with electric heater</b> <ul style="list-style-type: none"> <li>• <b>2-pipe fan coil unit with electric heater</b> (heating or cooling) ON/OFF</li> <li>• Chilled/heated ceiling with electric heater (heating or cooling) ON/OFF</li> <li>• 1-stage compressor with electric heater (heating or cooling) ON/OFF</li> </ul>		
<b>Heating or cooling</b> <ul style="list-style-type: none"> <li>• <b>4-pipe fan coil unit</b> ON/OFF (heating or cooling)</li> <li>• Chilled/heated ceiling ON/OFF (heating or cooling)</li> <li>• 1-stage compressor ON/OFF (heating or cooling)</li> </ul>		

Key	
<b>Y1</b>	Heating or heating/cooling valve actuator
<b>Y2</b>	Cooling valve actuator
<b>YE</b>	Electric heater
<b>M1</b>	3–or 1-speed fan
<b>B1</b>	Return air temperature sensor or external room temperature sensor (optional)
<b>B2</b>	Changeover sensor (optional)

1 Only required for heating AND cooling applications (see section: *Setpoints and sequences*)

## Functions *(continued)*

### Additional functions

#### Automatic heating/cooling changeover via changeover sensor

If an external temperature sensor is connected to X1/X2, and parameter P38/P40 is =2, the water temperature acquired by the changeover sensor is used to change over from heating to cooling mode, or vice versa.

- When the **water temperature** is above 28 °C (adjustable via parameter P37), the thermostat changes over to **heating mode**.  
It stays in heating mode until the temperature falls below 16 °C (adjustable via parameter P36).
- When the **water temperature** is below 16 °C (P36), the thermostat changes over to cooling mode.  
It stays in **cooling mode** until the temperature rises above 28 °C (P37).
- If the water temperature is between the 2 changeover points immediately after power-up (inside the hysteresis), the thermostat starts in previous mode.

The water temperature is acquired at 30-second intervals and the operating state is updated accordingly.

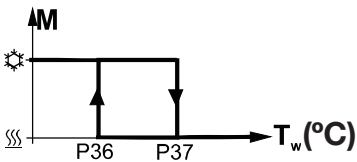

M Operating mode      ⚙ Cooling mode  
Tw Water temperature      🌊 Heating mode

#### Changeover switch

The temperature sensor for automatic heating/cooling changeover can be replaced by an external switch for manual, remote changeover:

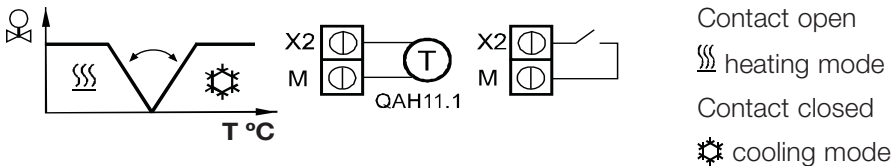

The sensor or switch can be connected to input terminal X2 or X1, depending on the commissioning of the inputs (P38, P40).

See also section: *Multifunctional input, digital input*.

#### Manual heating/cooling changeover

- Manual heating/cooling changeover means selection via changeover button on the thermostat by repeatedly pushing the button until the required mode is shown on the display (automatic changeover is done via an external sensor/switch connected to X1, X2, or D1).
- If manual heating/cooling changeover is commissioned (P01 = 2), then heating/cooling mode cannot be changed via changeover sensor/switch; it will remain in the last mode as selected locally via button.

#### External/return air temperature sensor

The thermostat acquires the room temperature via built-in sensor, external room temperature sensor, or external return air temperature sensor connected to multifunctional input X1 or X2.

Inputs X1 or X2 must be commissioned accordingly. See section: *Multifunctional input, digital input*.

*Continued on next page*

## Functions *(continued)*

### Additional functions *(continued)*

#### Purge function

The changeover sensor ensures changeover from heating to cooling mode based on the acquired water temperature. We recommend activating the “Purge” function (parameter P50) with 2-port valves. This function ensures correct acquisition of the medium temperature even if the 2-port valve is closed for an extended period of time. The valve is then opened for 1 to 5 minutes (adjustable) at 2-hour intervals during off hours.

**Notice:** The “Purge” function (parameter P50) must be disabled if the thermostat is used in compressor-based applications.

#### Avoid damage from moisture

In very warm and humid climates, the fan can be run periodically or continuously at a low fan speed (e.g. in empty apartments or shops) in Economy mode by setting parameter P61, in order to avoid damage from moisture due to lack of air circulation. See also section: *Fan control*, under *Fan kick function*.

#### Minimum output ON-time/OFF-time

Limit the ON/OFF switching cycle to protect the HVAC equipment, e.g. compressor and reduce wear and tear. The minimum output on-time and off-time for 2-position control output can be adjusted from 1 to 20 minutes via parameters P48 and P49.

The factory setting is 1 minute.

Readjusting the setpoint or heating/cooling mode changeover immediately results in calculation of the output state; the outputs may not hold the minimum 1-minute ON/OFF time.

If parameter P48 or P49 is set to above 1 minute, the minimum ON/OFF time for the control output is maintained as set, even if the setpoint or changeover mode is readjusted.

#### Floor heating/Floor cooling

All heating sequences can also be used for floor heating.

You can use fan coil unit heating/cooling sequences for floor heating or cooling by disabling the fan via parameter P52.

#### Floor temperature limitation function

The floor temperature should be limited for 2 reasons: Comfort and protection of the floor.

The floor temperature sensor, connected to multifunctional input X1 or X2, acquires the floor temperature. If the temperature exceeds the parameterized limit (parameter P51), the heating valve is fully closed until the floor temperature drops to a level 2 K below the parameterized limit.

This function is factory-set to OFF (disabled).

Input X1 or X2 must be commissioned accordingly (P38 or P40 = 1).

See section: *Multifunctional input, digital input*.

#### Recommended values for P51:

- Living rooms:  
Up to 26 °C for long-time presence, up to 28 °C for short-time presence.
- Bathrooms:  
Up to 28 °C for long-time presence, up to 30 °C for short-time presence.



## Functions *(continued)*

### Additional functions *(continued)*

The table below shows the relation between parameter, temperature source and temperature display:

Parameter P51	External temperature sensor available	Source for display of room temperature	Output control based on	Floor temperature limit function
OFF	No	Built-in sensor	Built-in sensor	Not active
OFF	Yes	External temperature sensor	External temperature sensor	Not active
10...50 °C	No	Built-in sensor	Built-in sensor	Not active
10...50 °C	Yes	Built-in sensor	Built-in sensor + limit by external sensor	Active

The “Floor temperature limitation” function influences the outputs listed in the table below:

Application	Output Y11	Output Y21	“Floor temperature limit” function has impact on:			Remark
			Heating (P01 = 0/2/3)	Cooling (P01 = 1/2/3)	Heating and cooling (P01 = 4)	
2-pipe	H/C valve		Y11	N/A		
2-pipe and electric heater	H/C valve	Electric heater	Y21	Y21 *		Only electric heater
4-pipe	Heating valve	Cooling valve	Y11	N/A	Y11	

\* If P13 = ON → electric heater in cooling mode

**Note:** Either floor temperature sensor or external room temperature sensor can be used.

### Dew point monitoring

Dew point monitoring is essential to prevent condensation on the chilled ceiling (cooling with fan disabled, parameter P52). It helps avoid associated damage to the building.

A dew point sensor with a potential-free contact is connected to multifunctional input X1 or X2. If there is condensation, the cooling valve is fully closed until no more condensation is detected, and the cooling output is disabled temporarily.

### Fault state/Fault information

The condensation symbol “” is displayed during temporary override. The input must be commissioned accordingly (P38, P40). See section: *Multifunctional input, digital input*.

### Button lock

Manual “button lock” function is enabled by parameter P14 (0=Disabled, 1=Auto lock, 2=Manual lock).

When P14=2, press operating mode button  for 5 seconds to lock or unlock all the buttons. If “Auto lock” is configured (P14=1), the thermostat will automatically lock all the buttons 10 seconds after the last adjustment and the way to unlock the buttons is the same as per manual lock.

## Functions *(continued)*

### Control sequences

#### Sequences overview (setting via parameter P01)

The main control sequence (i.e. the water coil sequence of the fan coil unit) can be set via **parameter P01**.

The following sequences can be activated in the thermostats (each without or with auxiliary heating).

The available sequences depend on the application (selected via DIP switch, see section: *Applications overview*).

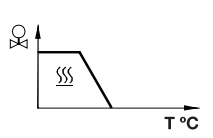
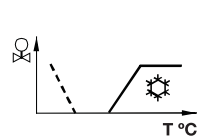
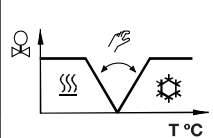
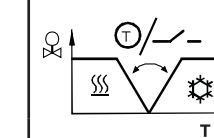
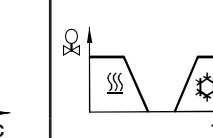
Parameter	P01 = 0	P01 = 1	P01 = 2	P01 = 3	P01 = 4
Sequence					
Available for basic application <sup>1</sup> ↓	Heating	Cooling ↘ = heating sequence for electric heater	Manually select heating or cooling sequence (using the button on the thermostat)	Automatic heating/cooling changeover via external water temperature sensor or remote switch	Heating and cooling sequence, i.e. 4-pipe
2-pipe, 2-pipe and electric heater	✓	✓	✓	✓	
4-pipe			✓ <sup>2</sup>	✓ <sup>2</sup>	✓

<sup>1</sup> For chilled/heated ceiling and radiator applications, see section: *Chilled/heated ceiling and radiator applications*; for compressor applications, see section: *Compressor applications*

<sup>2</sup> For manual and automatic changeover with 4-pipe applications, see section: *4-pipe fan coil unit*:

- 4-pipe manual changeover (P01 = 2) means activating either cooling or heating outputs
- 4-pipe automatic changeover (P01 = 3) means swapping the control outputs according to a heating/cooling sensor or remote switch ("main and secondary" application), see section: *4-pipe fan coil unit*

For the relation between setpoints and sequences, see section: *Setpoints and sequences*.

*Continued on next page*

## Functions *(continued)*

### Control sequences *(continued)*

#### 2-pipe fan coil unit

On 2-pipe applications, the thermostat controls a valve in heating/cooling mode with changeover (automatically or manually), heating only, or cooling only. Cooling only is factory-set (P01 = 1).

#### ON/OFF control

##### Control sequence ON/OFF output

The diagrams below show the control sequence for 2-position control.

##### Heating mode

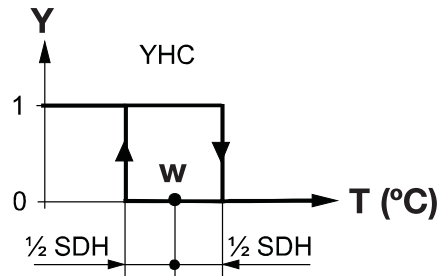

##### Cooling mode

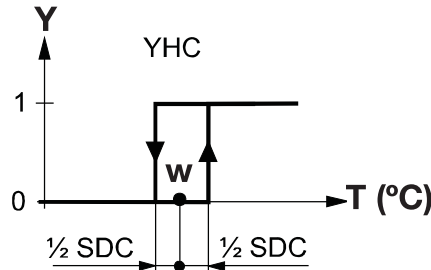

T (°C) Room temperature  
 w Room temperature setpoint  
 YHC Control command "Valve" or "Compressor"

SDH Switching differential "Heating" (P30)  
 SDC Switching differential "Cooling" (P31)

#### Modulating control: 3-position

##### Control sequence modulating output

The diagrams below show the control sequence for modulating PI control.

##### Heating mode

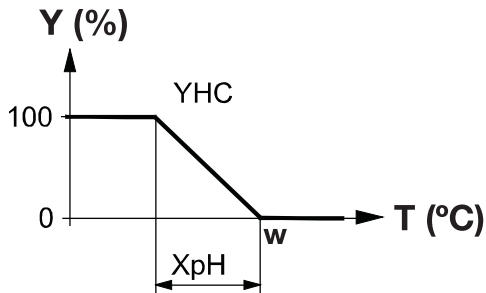

##### Cooling mode

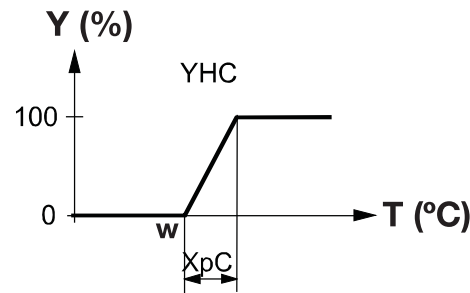

T (°C) Room temperature  
 w Room temperature setpoint  
 YHC Control command "Valve"

XpH Proportional band "Heating" (P30)  
 XpC Proportional band "Cooling" (P31)

**Note:** The diagrams only show the PI thermostat's proportional part.

#### Setting the sequence and the control outputs

Refer to sections: *Applications*, *Sequences overview*, and *Control outputs*.

*Continued on next page*

## Functions *(continued)*

### Control sequences *(continued)*

#### 2-pipe fan coil unit with electric heater

##### Heating or cooling with auxiliary heater

On 2-pipe applications with electric heater, the thermostat controls a valve in heating/cooling mode with changeover, heating only, or cooling only plus an electric heater.

Cooling only is factory-set (P01 = 1) with enabled electric heater (P13).

##### Electric heating, active in cooling mode

In cooling mode, the valve receives an **OPEN** command if the acquired temperature is above the setpoint.

The electric heater receives an **ON** command if the acquired room temperature drops below “setpoint” minus “dead zone” (= setpoint for electric heater) while the electric heater is enabled (parameter P13 = ON).

**Note:** “Setpoint for electric heater” is limited by parameter “Maximum setpoint for Comfort mode” (P10).

##### Electric heating in heating mode

In heating mode, the valve receives an **OPEN** command if the acquired temperature is below the setpoint. The electric heater is used as an additional heating source when the heating energy controlled by the valve is insufficient.

The electric heater receives an **ON** command, if the temperature is below “setpoint” minus “setpoint differential” (= setpoint for electric heater).

##### Electric heating and manual changeover

The electric heater is active in heating mode only and the control output for the valve is permanently disabled when manual changeover is selected (P01 = 2).

##### Digital input “Enable electric heater”

Remote enabling/disabling of the electric heater is possible via input X1 or X2 for tariff regulations, energy savings, etc. Input X1 or X2 must be commissioned accordingly (parameters P38, P40). See section 3.9 “Multifunctional input”.

**Notice:** An electric heater must always be protected by a safety limit thermostat!

*Continued on next page*

## Functions *(continued)*

### Control sequences *(continued)*

#### ON/OFF control

##### Control sequence ON/OFF output

The diagrams below show the control sequence for 2-position control.

##### Heating mode

*(automatic changeover = heating or heating only)*

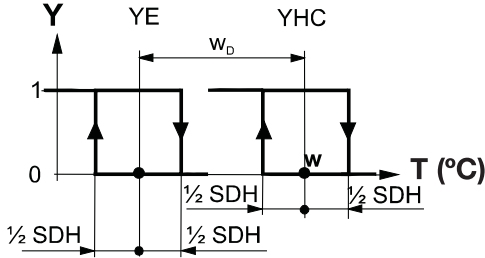

##### Cooling mode

*(manual/auto. changeover = cooling or cooling only)*

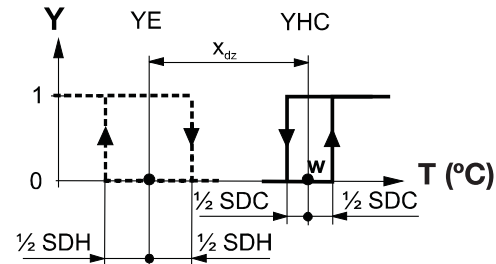

##### Heating mode with manual changeover (P01 = 2)

*(manual changeover = heating)*

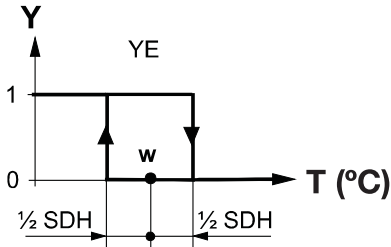

T (°C)	Room temperature
W	Room temperature setpoint
YHC	Control command "Valve" or "Compressor"
YE	Control command "Electric heater"
SDH	Switching differential "Heating" (P30)
SDC	Switching differential "Cooling" (P31)
X <sub>dz</sub>	Dead zone (P33)
w <sub>D</sub>	Setpoint differential (P34)

**Note:** The diagrams only show the PI thermostat's proportional part.

#### Setting the sequence and the control outputs

Refer to sections: *Applications*, *Sequences overview*, and *Control outputs*.

*Continued on next page*

## Functions *(continued)*

### Control sequences *(continued)*

#### 4-pipe fan coil unit

##### Heating and cooling

On 4-pipe applications, the thermostat controls 2 valves in heating and cooling mode, heating/cooling mode by manual selection, or heating and cooling mode with changeover. Heating and cooling mode (P01 = 4) is factory-set.

##### 4-pipe application with manual changeover

The heating or cooling output can be released via operating mode button if parameter P01 is set to Manual (P01 = 2).

##### ON/OFF control

The diagrams below show the control sequence for 2-position control.

Heating mode with manual selection (P01=2) or for P09 >= P10 in heating sequence\*

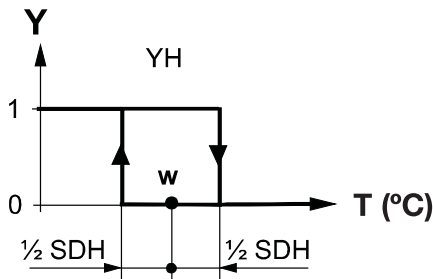

Cooling mode with manual selection (P01=2) or for P09 >= P10 in cooling sequence\*

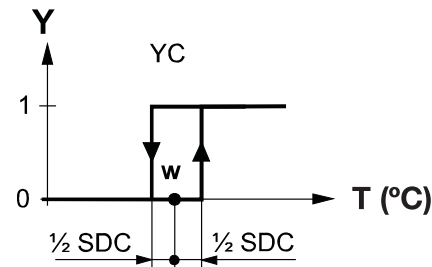

Heating and cooling mode (P01 = 04)

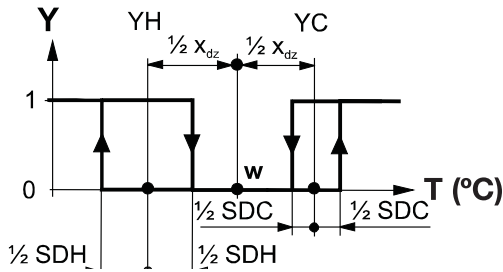

T (°C)	Room temperature
w	Room temperature setpoint
YH	Control command “Valve” or “Compressor” (H)
YC	Control command “Valve” or “Compressor” (C)
SDH	Switching differential “Heating” (P30)
SDC	Switching differential “Cooling” (P31)
X <sub>dz</sub>	Dead zone (P33)

**Note:** The diagrams only show the PI thermostat’s proportional part.

##### Setting the sequence and the control outputs

Refer to sections: *Applications*, *Sequences overview*, and *Outputs*.

*Continued on next page*

## Functions *(continued)*

### Control sequences *(continued)*

#### Chilled/heated ceiling and radiator applications

For chilled/heated ceiling and radiator,

- set the corresponding basic application
- disable the fan (P52)

The following applications are available:

Application for chilled/heated ceiling, and radiator	Set basic application	See section	Sequences
Chilled/heated ceiling with changeover	2-pipe	3.6.2	H ( \ ) C ( / )
Chilled/heated ceiling and electric heater (cooling only: disable electric heater via P13)	2-pipe and electric heater	3.6.3	EI H + H ( <del>↔</del> ) EI H + C ( <del>↔</del> ) C ( / )
Chilled ceiling and radiator	4-pipe	3.6.4	H + C ( \ / )

#### Compressor applications

For compressor applications,

- set the corresponding basic application
- disable the fan (P52) or set the fan speed (P53)

The following applications are available:

Application for compressor	Set basic application	See section	Sequences
1-stage compressor for heating or cooling	2-pipe	3.6.2	H ( \ ) C ( / )
1-stage compressor and electric heater (cooling only: disable electric heater via P13)	2-pipe and electric heater	3.6.3	EI H + H ( <del>↔</del> ) EI H + C ( <del>↔</del> ) C ( / )
1-stage compressor for heating and cooling	4-pipe	3.6.4	H + C ( \ / )

Notes:

Minimum ON/OFF time: P48/P49

Fan operation: P52 (0 = disabled, 1 = enabled)

Fan speed: P53 (1 = 1-speed, 2 = 3-speed)

*Continued on next page*

## Functions *(continued)*

### Control sequences *(continued)*

#### Setpoints and sequences

##### 2-pipe applications

On changeover applications, the Comfort setpoints for heating and cooling sequence are the same (W).

On 2-pipe applications with electric heater, the Comfort setpoint is either at the first heating sequence (in heating mode) or at the cooling sequence (in cooling mode).

The setpoints for Economy and Protection mode are below the Comfort setpoints (heating) and above the Comfort setpoints (cooling).

They can be set via parameters P11, P12 (Economy mode) and P65, P66 (Protection mode).

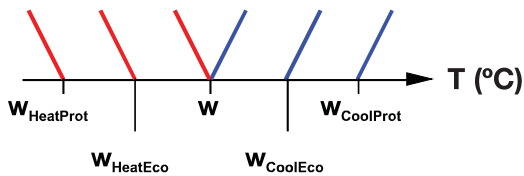

Application	Comfort mode		Economy/Protection mode	
	Heating	Cooling	Heating	Cooling
2-pipe				
2-pipe and electric heater				

<sup>1</sup> If P13 = ON

<sup>2</sup> In case of manual changeover (P01 = 2), the first heating sequence is disabled to prevent heating (electric heater) and cooling (coil) at the same time

**W** = Setpoint in Comfort mode

**W<sub>HeatEco/Prot</sub>** = Setpoint heating in Economy or Protection mode

**W<sub>CoolEco/Prot</sub>** = Setpoint cooling in Economy or Protection mode

**YR** = Radiator sequence

**YE** = Electric heater sequence

*Continued on next page*



## Functions *(continued)*

### Control sequences *(continued)*

#### Setpoints and sequences *(continued)*

##### 4-pipe applications

On 4-pipe applications, the Comfort setpoint ( $w$ ) is in the middle of the dead zone, between the heating and cooling sequence.

The dead zone can be adjusted via parameter P33.

If manual changeover is selected, then either the cooling sequence or the heating sequence is released. In this case, the Comfort setpoint is at the selected heating or cooling sequence.

Application	Comfort mode			Economy / Protection mode
	Heating and Cooling	Heating only <sup>1</sup>	Cooling only <sup>1</sup>	Heating and/or Cooling
4-pipe				

<sup>1</sup> Manual changeover, P01 = 2

**W** = Setpoint in Comfort mode

**WHeatEco/Prot** = Heating setpoint for Economy or Protection mode

**WCoolEco/Prot** = Cooling setpoint for Economy or Protection mode

**YE** = Electric heater sequence

## Functions *(continued)*

### Control Outputs

#### Overview

#### 4-pipe applications

Different control output signals are available. They need to be defined during commissioning (see below).

Control output Product no.	2-position	3-position
LR-HVAC-230-S	Y11, Y21 (2 x SPST)	Y11, Y21* (1 x ▲/▼)

\* Only on 2-pipe application

#### ON/OFF control signal (2-position)

The valve or compressor receives the **OPEN/ON** command via control output Y11 or Y21 when either:

1. The acquired room temperature is below the setpoint (heating mode) or above the setpoint (cooling mode).
2. The control outputs have been inactive for more than the “Minimum output OFF-time” (factory setting 1 minute, adjustable via parameter P48).

The valve or compressor receives the **OFF** command via control output Y11 or Y21 when either:

1. The acquired room temperature is above the setpoint (heating mode) or below the setpoint (cooling mode).
2. The valve has been active for more than the “Minimum output on-time” (factory setting 1 minute, adjustable via parameter P49).

#### Electric heater control signal (2-position)

The electric heater receives an **ON** command via the auxiliary heating control output (Y..., see Mounting Instructions) when either:

1. The acquired room temperature is below the “Setpoint for electric heater”
2. The electric heater has been switched off for at least 1 minute

The electric heater receives an **OFF** command via the auxiliary heating control output (Y..., see Mounting Instructions) when either:

1. The acquired room temperature is above the setpoint (electric heater)
2. The electric heater has been switched on for at least 1 minute

**Notice:** A safety limit thermostat (to prevent over-temperatures) must be provided externally.

#### Adaptive temperature compensation for electric heater

When an electric heater is connected directly to the **ON/OFF** Y21, the current causes the relay contact to heat up. This falsifies the reading of the internal temperature sensor. The thermostat compensates the temperature if the rated current/power of the electric heating is entered in the parameters P46 (load current el.heater): factory setting: 0 A, setting range: 0.0...5.0 A.

#### 3-position control signal

Output Y11 provides the OPEN command, and Y21 the CLOSE command to the 3-position actuator. The factory setting for the actuator's running time is 150 seconds. It can be adjusted via parameter P44. The parameter is only visible if 3-position is selected via DIP switches.

*Continued on next page*

## **Functions** *(continued)*

### **Control Outputs** *(continued)*

#### **Synchronization**

1. When the thermostat is powered up, a closing command for the actuator running time + 150% is provided to ensure that the actuator fully closes and synchronizes to the control algorithm.
2. When the thermostat calculates the positions "fully close" or "fully open", the actuator's running time is extended + 150% to ensure the right actuator position is synchronized to the control algorithm.
3. After the actuator reaches the position calculated by the thermostat, a waiting time of 30 seconds is applied to stabilize the outputs.

#### **Control outputs configuration (setting via DIP switches)**

For the control outputs of a 2-pipe application, either On/Off or 3-position can be set via DIP switches (see section 3.4). Other applications, e.g. 4-pipe and 2-pipe with electric heater, only have On/Off type of outputs.

## Functions *(continued)*

### Fan control

The fan operates in automatic mode or at the selected speed with manual mode.

In automatic mode, the fan speed depends on the setpoint and the current room temperature. When the room temperature reaches the setpoint, the control valve closes and the fan switches off or stays at fan speed 1 (parameter P60; factory setting: 0 = fan speed 1 in dead zone).

Only one fan output at a time is on, either Q1, Q2 or Q3.

#### 3-speed fan control with modulating heating/cooling control

The individual switching points for ON of each fan stage can be adjusted via control parameters P55...P57. The fan speed switch off point is 20% below the switch on point. The diagrams below show fan speed control for modulating PI control.

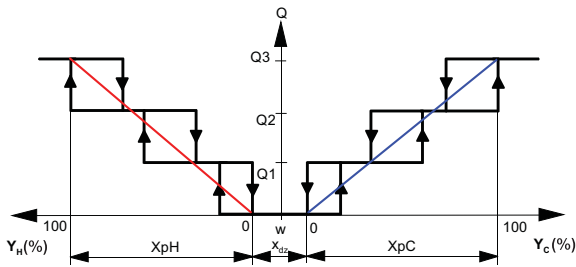

- w** Room temperature setpoint
- Q** Fan speed
- Y<sub>H</sub> \** Control demand "Heating"
- Y<sub>C</sub> /** Control demand "Cooling"
- X<sub>pH</sub>** Proportional band "Heating"
- X<sub>pC</sub>** Proportional band "Cooling"
- X<sub>dz</sub>** Dead zone

**Note:** The diagram only shows the PI thermostat's proportional part.

#### 3-speed fan control with ON/OFF heating/cooling control

On applications with 2-position control:

- The switching point for low fan speed (Q1) is synchronized to the heating/cooling output. Parameter "Switching point fan speed low" P57 is not relevant.
- The maximum switching range of the fan (XpHFan/XpCFan) is defined by the switching differential (SDH/SDC) via a look-up table.

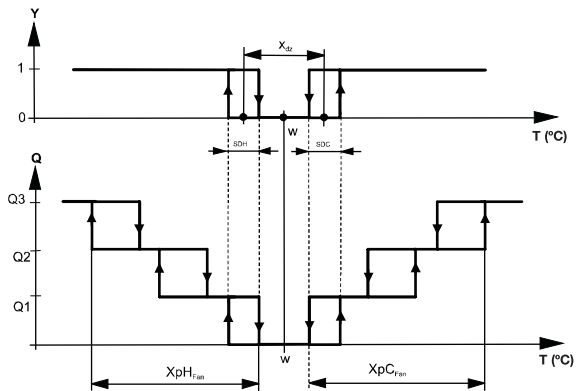

- T (°C)** Room temperature
- w** Room temperature setpoint
- Q** Fan speed
- SDH** Switching differential "Heating"
- SDC** Switching differential "Cooling"
- X<sub>dz</sub>** Dead zone
- X<sub>pHFan</sub>** Switching range for fan "Heating"
- X<sub>pCFan</sub>** Switching range for fan "Cooling"

#### Look-up table with ON/OFF control

SDH/SDC (K)	0.5	1.0	1.5	2.0	2.5	3.0	3.5	4.0	> 4.5
XpHFan/XpCFan (K)	2	3	4	5	6	7	8	9	10

*Continued on next page*

## Functions *(continued)*

### Fan control *(continued)*

#### 1-speed/3-speed fan

The thermostat can control a 1- or 3-speed fan (selected via control parameter P53). A 1-speed fan is connected to terminal Q1, a 3-speed fan to terminals Q1, Q2 and Q3.

#### Fan operation as per heating/cooling mode, or disabled

Fan operation can be limited to be active with cooling only or heating only, or even be totally disabled via control parameter "Fan control" P52.

When fan operation is disabled, the fan symbol on the display disappears and pressing the fan button has no impact.

This function allows you to use the thermostat on universal applications such as chilled/heated ceilings and radiator, etc. (see section 3.6.5).

#### Fan minimum on-time

In automatic mode, a dwelling time of 2 minutes (factory setting) is active. The fan maintains each speed for at least 2 minutes before it changes to the next speed. This minimum on-time can be adjusted from 1 to 6 minutes via parameter P59.

#### Fan operation in dead zone (fan kick)

In automatic fan mode and with the room temperature in the dead zone, the control valve is normally closed and the fan disabled. With the "Fan kick" function, the fan can be released from time to time at low speed for minimum on-time (see above) even if the valve is closed.

This function can be used to avoid damage from moisture due to a lack of air circulation, or to allow a return air temperature sensor to acquire the correct room temperature.

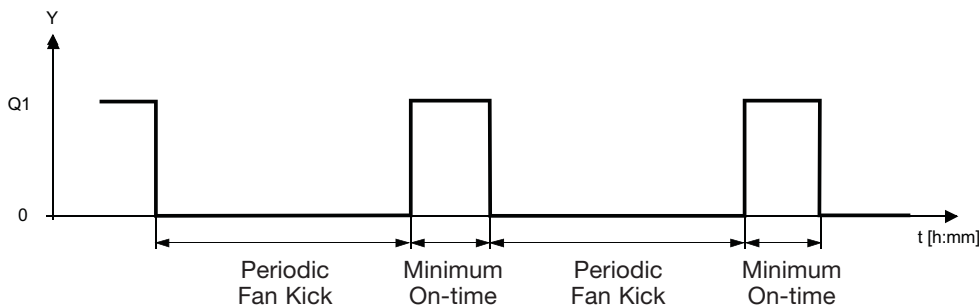

The periodic fan kick time can be selected individually for Comfort mode via parameter P60, and for Economy mode via parameter P61.

**Note:** Fan kick value "0" means the fan runs continuously in the dead zone.  
Fan kick value "OFF" means the fan does not run in the dead zone.

*Continued on next page*

## Functions *(continued)*

### Fan control *(continued)*

#### Fan start

When the fan starts from standstill, it starts at speed 3 for one second to ensure safe fan motor start by overcoming inertia and friction (selected via parameter P58).

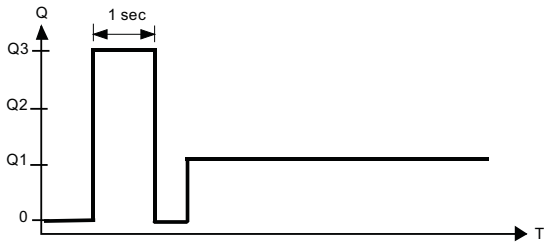

#### Fan overrun for electric heater

When the electric heater is switched off, the fan overruns for 60 seconds (parameter P54) to avoid over-temperature of the electric heater or prevent the thermal cutout from responding.

#### Notice: Fan Failure

In case of fan failure, the thermostat cannot protect the electric heater against over-temperature. For this reason, the electric heater must feature a separate safety device (thermal cutout).

#### Clean fan filter reminder

The "Clean fan filter reminder" function counts the fan operating hours and displays message "FIL" to remind the user to change/clean the fan filter as soon as the threshold is reached. This does not impact the thermostat's operation, which continues to run normally. This function can be set via parameter P62 (Service Filter).

## Functions *(continued)*

### Multifunctional input, digital input

The thermostat has 2 multifunctional inputs X1 and X2.

An NTC type sensor like the QAH11.1 (AI, analog input) or a switch (DI, digital input) can be connected to the input terminals. The functionality of the inputs can be configured via parameters P38 + P39 for X1 and P40 + P41 for X2.

The parameters can be set to the following values:

#	Function of input	Description	TypeX1 / X2
0	Not used	No function.	—
1	External/return air temperature	Sensor input for external room temperature sensor or return air temperature sensor to acquire the current room temperature, or floor heating temperature sensor to limit the heating output. <b>Note:</b> The room temperature is acquired by the built-in sensor if the floor temperature limitation function is enabled via parameter P51.	AI
2	Heating/cooling changeover	Sensor input for “Automatic heating/cooling changeover” function. A switch can also be connected rather than a sensor (switch closed = cooling, see section 3.5). Diagnostic value 0 °C is displayed for closed contact/ 100 °C for open contact, if a switch is connected.	AI/DI
3	Operating mode switchover	Digital input to switch over the operating mode to Economy. If the operating mode switchover contact is active, user operations are ineffective and “OFF” is displayed.	DI
4	Dew point monitor	Digital input for a dew point sensor to detect condensation. Cooling is stopped if condensation occurs.	DI
5	Enable electric heater	Digital input to enable/disable the electric heater via remote control.	DI
6	Fault	Digital input to signal an external fault (example: dirty air filter). If the input is active, “ALx” is displayed and a fault is sent to the Lutron® GCU-HOSP unit.	DI
7	NA	—	—
8	NA	—	—

- Operational action can be changed between normally open (NO) and normally closed (NC) via parameter P39, P41
- Each input X1 or X2 must be configured with a different function (1...5). Exception: 1 or 2 inputs can be configured as fault (6) or monitor input (7,8)
- X1 is factory-set to “Operating mode switchover” (3), X2 to “External sensor” (1)

If a multifunctional input is configured as analog: "Err" will be displayed when the output is out of range (0...49 °C), open or shorted.

For more detailed information, refer to section 3.4 “Applications”.

### Installation notes:

- For inputs X1 and X2, one physical switch can be used for up to 20 thermostats (parallel connection).
- For sensors on inputs X1, X2, or D1, the cable length is up to 80 m maximum.

## Functions *(continued)*

### Handling faults

#### Temperature out of range

When the room temperature is outside the measuring range, i.e. above 49 °C or below 0 °C, the limiting temperatures blink, e.g. "0 °C" or "49 °C".

In addition, the heating output is activated if the current setpoint is not set to "OFF", the thermostat is in heating mode and the temperature is below 0 °C.

For all other cases, no output is activated.

The thermostat resumes Comfort mode after the temperature returns to within the measuring range.

### Modbus RTU mode

The LR-HVAC-230-S thermostats support communication to a Lutron® system processor via Modbus.

#### Device address

The device address range is from 1 to 247.

The device address can be changed via parameter P81. (factory setting = 1)

#### Baud rate

The available baud rates are 4800 bps, 9600 bps, 19200bps and 38400 bps.

The baud rate can be changed via parameter P68. (factory setting = 19200 bps)

The baud rate must be set to 119200 bps for communication with the Lutron® GCU-HOSP or HQP6-2 processor unit.

#### Parity

The parity can be set to none (no parity), odd or even.

The parity can be changed via parameter P70. (factory setting = even)

The parity must be set to "even" for communication with the Lutron® GCU-HOSP or HQP6-2 processor unit.

**Note:** Any change, e.g. device address, baud rate and parity, will become effective only after turning the power supply off then on again.



## Fault function

### Fault information

If a fault occurs (e.g. digital fault input, dew point, etc.) then a fault will be displayed on the thermostat.

### Priority of alarms

If more than one alarms occur at the same time, the thermostat will display all active alarms alternatively.

The table below shows the error code and default alarm texts.

Priority	Fault	Thermostat
		Display
-	No fault	---
1	Condensation	🔔💧
2	External fault input X1	🔔 AL1
3	External fault input X2	🔔 AL2
4	Clean filter reminder	🔔 FIL

## Functions *(continued)*

### Control parameters

A number of control parameters can be readjusted to optimize control performance. This can be done on the thermostat via HMI or via commissioning/operating tool. These parameters can also be set during operation without opening the unit.

In the event of a power failure, all control parameter settings are retained.

The control parameters are assigned to 2 levels:

- “Service level” and
- “Expert level” including communications, diagnostics and test

The “Service level” contains a small set of parameters to set up the thermostat for the HVAC system and to adjust the user interface. These parameters can be adjusted any time.

Change parameters at the “Expert level” carefully, as they impact the thermostat’s control performance and functionality.

### Parameter setting via local HMI

#### Enter only “Service” level

1. Press buttons + and – simultaneously for 3 seconds. Release and press button + again for 3 seconds within 2 seconds. The display shows “P01.”

Continue with step 2.

#### Enter “Service” and “Expert” level

1. Press buttons + and – simultaneously for 3 seconds. Release and press button – again for 3 seconds within 2 seconds. The display shows “P01” and service.

#### Adjust parameters

2. Repeatedly press the + or – button to select the required parameter.

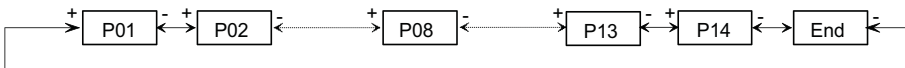

3. Press + and – simultaneously. The current value of the selected parameter begins to flash, allowing you to change the value by repeatedly pressing + or –.
4. The next parameter is displayed when you press + and – again simultaneously.
5. Repeat steps 2 to 4 to display and change additional parameters.
6. Press + or – until “End” is displayed, and then press + and – simultaneously to save the change and exit parameter entry mode.

#### Reset parameters

The factory setting for the control parameters can be reset via parameter P71, by changing the value to “ON”, and confirming by pressing buttons + and – simultaneously. The display shows “8888” during reset.

*Continued on next page*

## Functions *(continued)*

### Control parameters *(continued)*

#### Parameters of the “Service level”

Parameter	Name	Factory setting	Range
	Service level		
P01	Control sequence	2-pipe: (0...3) 1 (Cooling only) 4-pipe: (2...4) 4 (Heating & Cooling)	0 = Heating only 1 = Cooling only 2 = Manual Heating or Cooling 3 = Auto Changeover 4 = Heating & cooling
P02	Mode selection by user via operating mode button	1 (Comfort, Protection)	1 = Comfort, Protection 2 = Comfort, Energy Saving, Protection
P04	Selection of °C or °F	°C	0 = °C 1 = °F
P05	Sensor calibration	0.0 °C	-3...3 °C
P06	Standard temperature display	0 (Room temperature)	0 = Room temperature 1 = Setpoint
P07	Additional user information	0 (no display)	0 = No display 1 = Temperature in °C/°F 2 = Outside temperature(via Modbus) 3 = Time of day (12 h, via Modbus) 4 = Time of day (24 h, via Modbus)
P08	Comfort basic setpoint	21 °C	5...40 °C
P09	Minimum setpoint limitation in Comfort ( $W_{min_{Comf}}$ )	5 °C	5...40 °C
P10	Maximum setpoint limitation in Comfort ( $W_{max_{Comf}}$ )	35 °C	5...40 °C
P11	Setpoint of heating in Energy Saving	15 °C	OFF, 5 °C... $W_{cool_{Eco}}$
P12	Setpoint of cooling in Energy Saving	30 °C	OFF, $W_{heat_{Eco}}$ ...40 °C
P13 <sup>1</sup>	Electrical heater in cooling mode	ON	OFF = Disabled ON = Enabled
P14	Button lock (Press operating mode button  for 5 seconds to lock or unlock the buttons)	0 (Disabled)	0 = Disabled 1 = Auto lock 2 = Manual lock

<sup>1</sup> Parameter P13 is only displayed for application "2-pipe with electric."  
All temperature settings are in increments of 0.5 °C.

*Continued on next page*

**Functions (continued)****Control parameters (continued)****Parameters of the "Expert level with diagnostics and test"**

Parameter	Name	Factory setting	Range
	Service level		
P30	P-band/Switching differential for heating mode	2 K	0.5 ... 6 K
P31	P-band/Switching differential for cooling mode	1 K	0.5 ... 6 K
P33	Dead zone in Comfort mode	2 K	0.5 ... 5 K
P34	Setpoint differential	2 K	0.5 ... 5 K
P35 <sup>2</sup>	Integral time	5 minute	0...10 minute
P36 <sup>2</sup>	Heating/cooling changeover switching point for cooling	16 °C	10...25 °C
P37 <sup>2</sup>	Heating/cooling changeover switching point for heating	28 °C	27...40 °C
P38	Input X1	3 = Op mode c/o	0 = --- (no function) 1 = Room temp ext. sensor/Return air temp (AI) 2 = H/C changeover (AI/DI) 3 = Operating mode contact (DI) 4 = Dew point sensor (DI) 5 = Enable electric heater (DI) 6 = Fault input (DI) 7 = Monitor input (Digital) 8 = Monitor input (Temp)
P39	Operating action for X1 if digital input	NO	NO = Normally Open NC =Normally Close
P40	Input X2	1 = Exterior sensor	0 = --- (no function) 1 = Room temp ext. sensor/Return temp (AI) 2 = H/C changeover (AI/DI) 3 = Operating mode contact (DI) 4 = Dew point sensor (DI) 5 = Enable electric heater (DI) 6 = Fault input (DI) 7 = Monitor input (Digital) 8 = Monitor input (Temp)
P41	Operating action for X2 if digital input	0 (N.O.)	0 = Normally Open 1 = Normally Close
P44 <sup>3</sup>	Actuator running time Y11/Y21	150 second	20...300 second
P46	Y2x load current	0.0 A	0.0 to 5.0 A
P48	On time minimum for 2-position output control	1 minute	1...20 minute
P49	Off time minimum for 2-position output control	1 minute	1...20 minute
P50	Purge time	OFF	OFF: Not active 1...5 minute: Active with selected duration
P51	Flow temp limit floor heating	OFF	OFF, 10...50 °C

*Continued on next page*

## Functions *(continued)*

### Control parameters *(continued)*

#### Parameters of the "Expert level with diagnostics and test" *(continued)*

Parameter	Name	Factory setting	Range
	Service level		
P52	Fan control	1	0 = Disabled 1 = Enabled 2 = Heating only 3 = Cooling only
P53	Fan speeds	2	1 = 1-speed 2 = 3-speed
P54 <sup>1</sup>	Fan overrun time	60 s	
P55	Fan speed switching point high	100%	
P56	Fan speed switching point med	65%	
P57	Fan speed switching point low	10%	
P58	Fan start kick	ON	
P59	Fan minimum on time	2 minute	
P60	Periodic fan kick Comfort	0	
P61	Periodic fan kick Eco	OFF	
P62	Service filter	OFF (0)	
P65	Protection heating setpoint	8 °C	
P66	Protection cooling setpoint	OFF	
P68	Baud Rate	2	
P69	Temporary Comfort setpoint	OFF	
P70	Parity	1	
P71	Restore factory setting	OFF	
P81	Device address	1	

- <sup>1</sup> Parameter P54 is only displayed for application "2-pipe with electric". All temperature settings are in increments of 0.5 °C.
- <sup>2</sup> Parameters P36-37 and P50 will only appear when either X1 or X2 set to 2, the H/C changeover.
- <sup>3</sup> Parameters P35 and P44 will only appear when the application (DIP switch) set to 2 pipe 3 position.

**Functions** *(continued)***Control parameters** *(continued)***Parameters of the "Expert level with diagnostics and test"** *(continued)*

Parameter	Name	Range	
	Diagnostics & test		
d01	Application number	NONE	(No application)
		2P	2-pipe
		2P3P	2-pipe 3-position
		2PEH	2-pipe with electric heater
		4P	4-pipe
d02	X1 state	0	Not activated (for DI)
		1	Activated (DI)
		0...49 °C	Current temp. value (for AI)
		00 ⚙	H/C Input shorted
		100 ∞	H/C Input open
d03	X2 state	0	Not activated (for DI)
		1	Activated (DI)
		0...49 °C	Current temp. value (for AI)
		00 ⚙	H/C Input shorted
		100 ∞	H/C Input open
d05 <sup>1</sup>	Test mode for checking the Y11/Y21 This parameter can only be quit when the setting is back at "---" Press buttons + and – simultaneously to escape.actuator's running direction	"---"	no signal on outputs Y11 and Y21
		OPE	output Y11 forced opening
		CLO	output Y21 forced closing

<sup>1</sup> Parameters d05 will only appear when the application (DIP switch) set to 2 pipe 3 position.

## Handling

### Mounting and installation

Mount the room thermostat on a recessed rectangular conduit box with 60.3 mm fixing centers. Do not mount on a wall in niches or bookshelves, behind curtains, above or near heat sources, or exposed to direct solar radiation. Mount about 1.5 m above the floor.

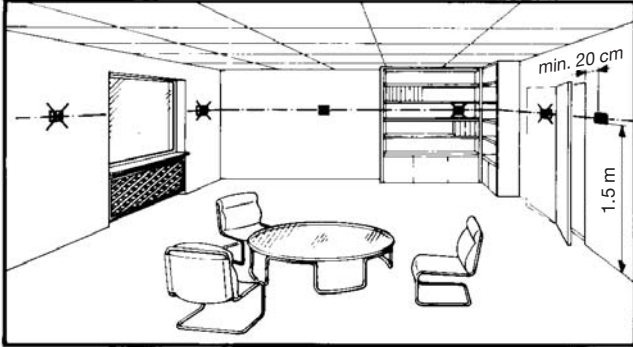

### Mounting

- Mount the room thermostat in a clean, dry indoor place without direct airflow from a heating/cooling device, and not exposed to dripping or splashing water.
- In case of limited space in the conduit box, use Siemens mounting bracket ARG70.3 to increase the headroom by 10 mm.

### Wiring

- See Mounting Instructions enclosed with the thermostat.
- Comply with local regulations to wire, protect and earth the thermostat.
- The device has no internal fuse for supply lines to fan and actuators. To avoid risk of fire and injury due to short-circuits, the 230 V $\sim$  mains supply line must have a circuit breaker with a rated current of no more than 10 A.
- Properly size the cables to the thermostat, fan and valve actuators for 230 V $\sim$  mains voltage.
- Use only valve actuators rated for 230 V $\sim$ .
- The wiring cross section used for power supply (L, N), fan/relays (Qxx) and 230 V $\sim$  outputs (Yxx -N) must be adapted to the preceding overload protection elements (max 10 A) under all circumstances. Comply under all circumstances with local regulations.
- Cables of SELV inputs X1-M / X2-M: Use cables with min 230 V $\sim$  insulation, as the conduit box carries 230 V $\sim$  mains voltage.
- Inputs X1-M or X2-M: Several switches (e.g. summer/winter switch) may be connected in parallel. Consider overall maximum contact sensing current for switch rating.
- Isolate the cables of Modbus communication input MUX,  $\overline{\text{MUX}}$  and COM from 230 V $\sim$ .
- No metal conduits.
- No cables provided with a metal shield.
- Disconnect from supply before opening the cover.

## Handling *(continued)*

### Commissioning

#### Applications

The room thermostats are delivered with a fixed set of applications.

Select and activate the relevant application during commissioning using the Local DIP switch and HMI.

#### DIP switches

Set the DIP switches before snapping the front panel to the mounting plate.

After power is applied, the thermostat starts with all LCD segments flashing for about 3 seconds. Then, the thermostat will be at normal display mode and is ready for commissioning by qualified HVAC staff.

If all DIP switches are OFF, the display reads "NONE" to indicate that application selection via DIP switches is required.

**Note:** Each time after a different application is selected, the thermostat reloads the factory settings for all control parameters EXCEPT the parameters for communication settings. e.g. device addresses (P81), Baud rate (P68) and Parity (P70).

#### Control parameters

The thermostat's control parameters can be set to ensure optimum performance of the entire system. The parameters can be adjusted using the Local HMI.

The control parameters of the thermostat can be set to ensure optimum performance of the entire system (see section 3.13, control parameters).

#### Compressor-based applications

- When the thermostat is used with a compressor, adjust the minimum output on-time (parameter P48) and OFF-time (parameter P49) for Y11/Y21 to avoid damaging the compressor or shortening its life due to frequent switching.

#### Calibrate sensor

- Recalibrate the temperature sensor if the room temperature displayed on the thermostat does not match the room temperature measured (after min. 1 hour of operation). To do this, change parameter P05.

#### Setpoint and range limitation

- We recommend to review the setpoints and setpoint ranges (parameters P08...P12) and change them as needed to achieve maximum comfort and save energy.



## Handling *(continued)*

### Operation

Also see the Operating Instructions enclosed with the thermostat.

### Layout



- 1 Operating mode selector
- 2 Button to change fan operation
- 3 Buttons to adjust setpoints and control parameters

### Button operation

User action	Effect, description
Normal operation	Actual operating mode and state are indicated by symbols
Press any button (thermostat in normal operation)	Backlit LCD turns on and... (see below for further action) After the last operation and a timeout of 20 seconds, the LCD backlight turns off
Press left button	Change operating mode
Press left button (P01 = 2)	Toggle between heating and cooling
Press left button > 5 seconds	Activate/deactivate button lock
Press right button	Change fan mode
Press + or -	Adjusts the Comfort room temperature setpoint. Thermostat changes to Comfort mode
Press + and - > 3 seconds, release, then press + again > 3 seconds	Go to parameter setting mode "Service level"
Press + and - > 3 seconds, release, then press - again > 3 seconds	Go to parameter setting mode "Expert level", diagnostics and test

## Handling *(continued)*

## Operation *(continued)*

### Display

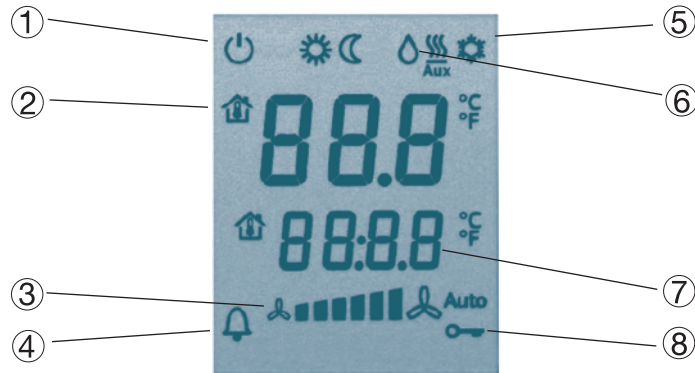

#### ① Operating mode

- Protection
- Comfort
- Economy

#### ② Displays room temperature, setpoints and control parameters

- Symbol indicates current room temperature

#### ③ Fan mode

- Auto fan active
- Fan speed low, medium, high

#### ④ Indicates fault or reminder

#### ⑤ Heating/cooling mode

- Cooling
- Heating
- Electrical heater active

#### ⑥ Condensation in room (dew point sensor active)

#### ⑦ Additional user information, Example: Room temperature in °C or °F

#### ⑧ Button lock active

## Connection

### Connection terminals

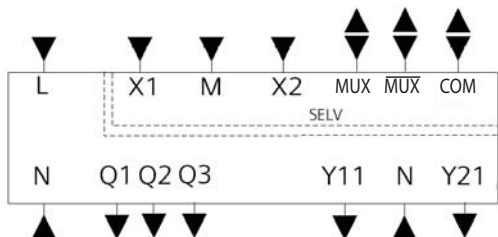

L, N	Operating voltage 230 V~
Q1	Control output “Fan speed 1 230 V~”
Q2	Control output “Fan speed 2 230 V~”
Q3	Control output “Fan speed 3 230 V~”
Y11, Y21	Control output “Valve” 230 V~ (N.O., for normally closed valves), output for compressor or output for electrical heater
X1, X2	Multifunctional input for temperature sensor or potential-free switch Factory setting: X1 = Operating mode switchover contact X2 = External sensor (function can be selected via parameter P38/P40).
M	Measuring neutral for sensor and switch
MUX	RS485 Modbus connection
$\overline{\text{MUX}}$	RS485 Modbus connection
COM	RS485 Modbus signal/common ground

## Connection *(continued)*

### Connection diagrams

#### Application

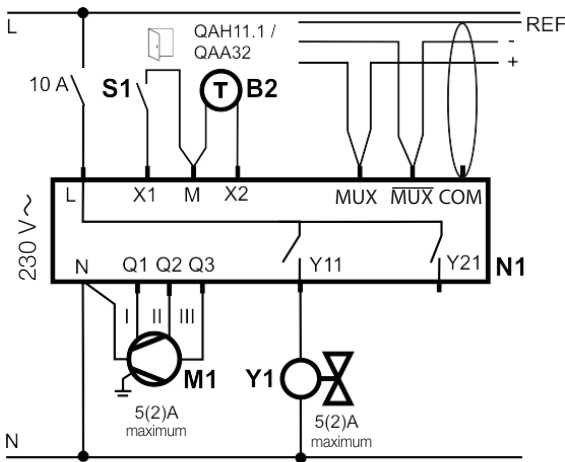

- N1 Room thermostat LR-HVAC-230-S
- M1 1- or 3-speed fan
- V1 Valve actuator, 2- or 3-position
- V1, V2 Valve actuator, 2-position
- E1 Electric heater
- C1, C2 1-stage compressor
- S1, S2 Switch (keycard, window contact, presence detector, etc.)
- B1, B2 Temperature sensor (return air temperature, external room temperature, changeover sensor, etc.)
- MUX RS485 Modbus connection
- $\overline{\text{MUX}}$  RS485 Modbus connection
- REF RS485 Modbus signal/common ground
- 5 (2) A 5 A: Resistive  
2 A: Inductive

2-pipe/heating or cooling –  
ON/OFF

2-pipe/heating or cooling –  
3-position  
– Y11 = Open  
– Y21 = Close

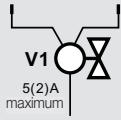

2-pipe and electric heater  
Heating or cooling  
and electric heater

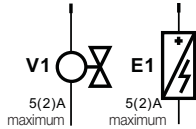

4-pipe/  
Heating and radiator  
– V1 = Heating  
– V2 = Cooling

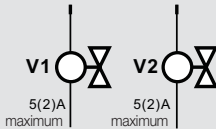

1-stage compressor  
– C1 = Heating and/or  
– C2 = Cooling

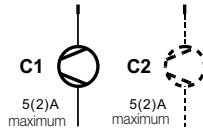

1-stage compressor and  
electric heater



## Mechanical design

### General

The thermostat consists of two parts:

- Front panel with electronics, operating elements and built-in room temperature sensor.
- Mounting base with power electronics.
  - The rear of the mounting base contains the screw terminals.
  - The base fits on a rectangular conduit box with 60.3 mm fixing centers.
  - Slide the front panel in the mounting base and snap on.

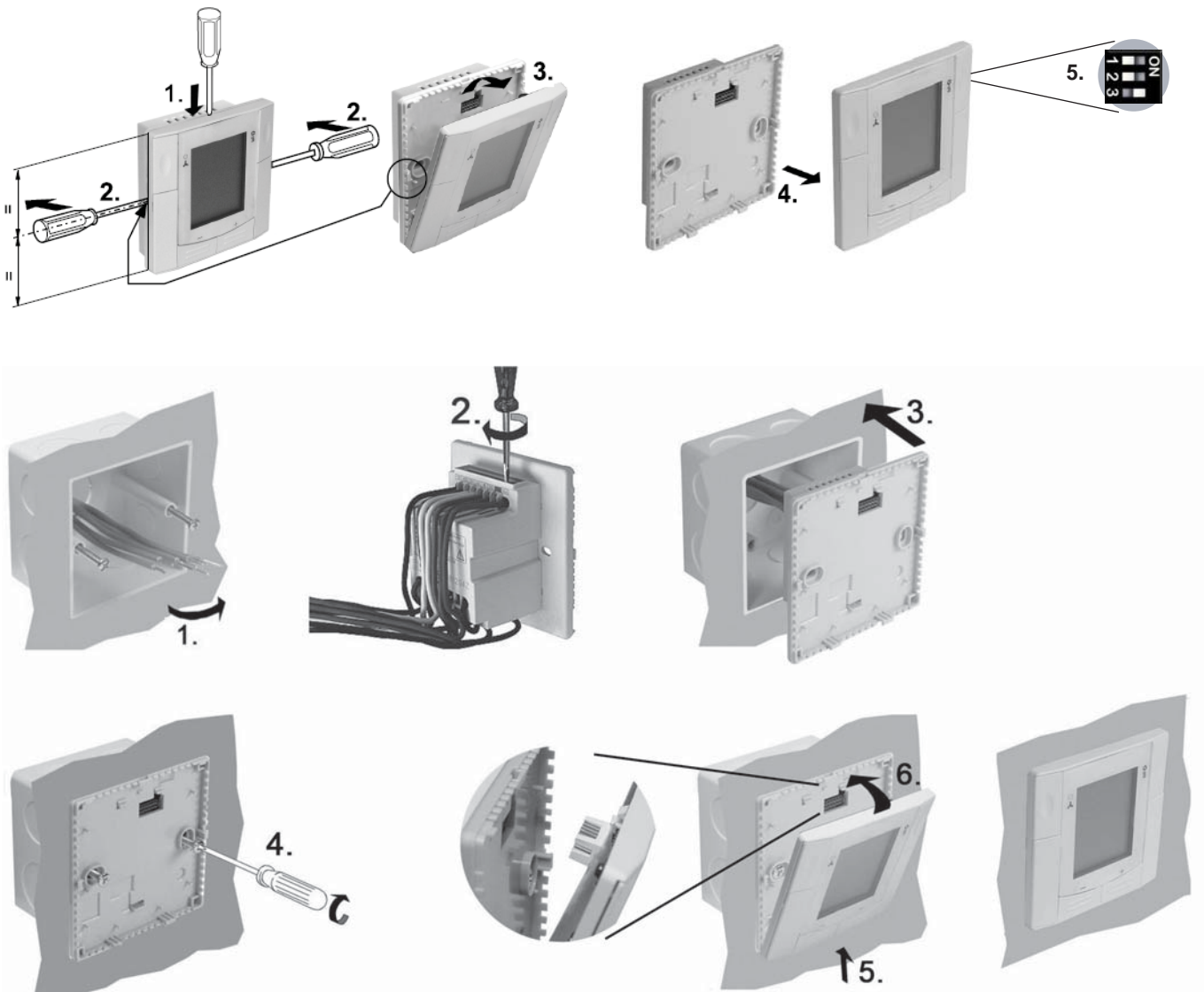

## Operation and settings

1. Operating mode selector
2. Change fan operation
3. Adjust setpoints and control parameters



## Dimensions (mm)

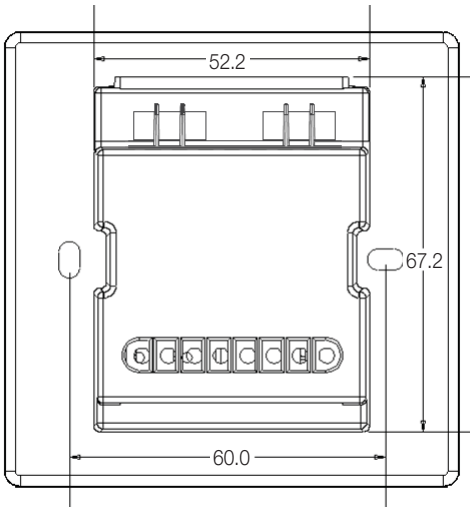
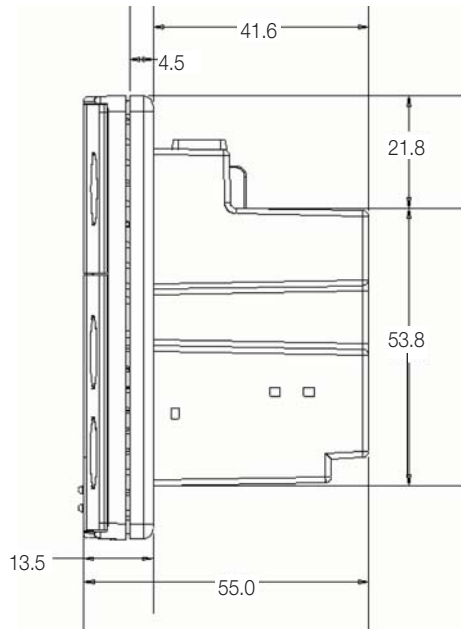
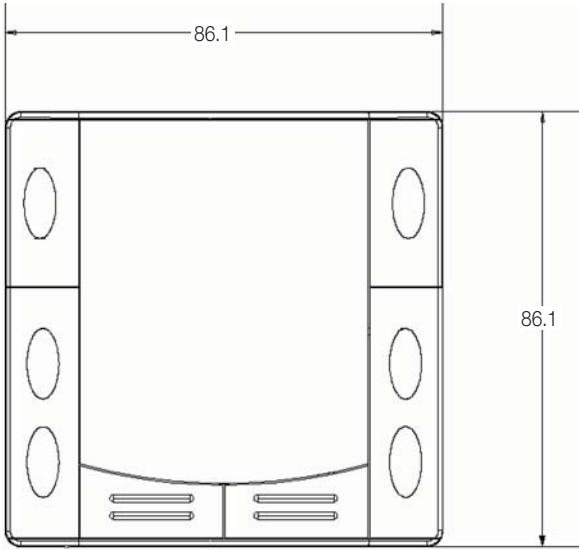

## Technical data

### Power supply

Rated voltage	230 V~
Overvoltage category	III
Frequency	50/60 Hz
Power consumption	Max. 7 VA/3.7 W

**Notice: No internal fuse!**

External preliminary protection with max C 10 A circuit breaker required in all cases.

### Outputs

Fan control Q1, Q2, Q3-N:	230 V~
– Rating:	Max. 5(2) A; 5 A resistive, 2 A Inductive

**Notice: Fans must NOT be connected in parallel!**

Connect one fan directly, for additional fans, use an additional relay for each speed.

Control output Y11-N/Y21-N (N.O.)	230 V~
– Rating	Max. 5(2) A; 5 A resistive, 2 A Inductive

**Notice: No internal fuse!**

External preliminary protection with max C 10 A circuit breakers in the supply line required in all cases.

### Inputs

Multifunctional input X1-M/X2-M

– Temperature sensor input:	
· Type	See “Equipment combinations”
· Temperature range	0 °C to 49 °C
· Cable length	Max. 80 m
– Digital input:	
· Operating action	Selectable (NO/NC)
· Contact sensing	SELV 0–5 V== max 5 mA
· Parallel connection of several thermostats for one switch	Max. 20 thermostats per switch
– Insulation against mains voltage (SELV)	4 kV, reinforced insulation

**Function of inputs:**

· External temperature sensor, heating/cooling changeover sensor, operating mode switchover contact, dew point monitor contact, enable electrical heater contact, fault contact, monitoring input	Selectable X1: configured using parameter P38 X2: configured using parameter P40
---	--

### Modbus

Interface type	RS485 Modbus RTU, Wire (ref.): 18 AWG, 1 pair, shielded serial line with 1.5 mm <sup>2</sup> and length < 1 200 m
Bus current	Max. 50 mA

*Continued on next page*



## Technical data *(continued)*

### Operational data

#### Switching differential, adjustable

- Heating mode (P30) 2 K (0.5–6 K)
- Cooling mode (P31) 1 K (0.5–6 K)

#### Setpoint setting and range

-  Comfort (P08) 21 °C (5 °C to 40 °C)
-  Economy (P11-P12) 15 °C/30 °C (OFF, 5 °C to 40 °C)
-  Protection (P11-P12) 8 °C/OFF (OFF, 5 °C to 40 °C)

Multifunctional input X1/X2

Selectable 0...8

Input X1 default value (P38)

3 (Op. Mode switchover)

Input X2 default value (P40)

1 (External temp. sensor)

Built-in room temperature sensor

- Measuring range 0 °C to 49 °C
- Accuracy at 25 °C < ± 0.5 K
- Temperature calibration range ± 3.0 K

Settings and display resolution

- Setpoints 0.5 °C
- Current temperature value displayed 0.5 °C

### Environmental conditions

Operation

As per IEC 60721-3-3

– Climatic conditions

Class 3K5

– Temperature

0 °C to 50 °C

– Humidity

< 95% relative humidity

Transport

As per IEC 60721-3-2

– Climatic conditions

Class 2K3

– Temperature

– 25 °C to 60 °C

– Humidity

< 95% relative humidity

– Mechanical conditions

Class 2M2

Storage

As per IEC 60721-3-1

– Climatic conditions

Class 1K3

– Temperature

– 25 °C to 60 °C

– Humidity

< 95% relative humidity

*Continued on next page*

## Technical data *(continued)*

### Standards and directives

– EU Conformity (CE)	8000079200_XX_A
– Electronic control type	2.B (micro-disconnection on operation)
Safety class	II as per EN 60730
Pollution class	Normal
Degree of protection of housing	IP 30 as per EN 60529

### Environmental compatibility

The product environmental declaration CE1E3079en contains data on environmentally compatible product design and assessments (RoHS compliance, materials composition, packaging, environmental benefit, disposal).

### General

Connection terminals	Solid wires or prepared stranded wires 1 x 0.4...1.5 mm <sup>2</sup>
Housing front color	RAL 9003 white
Weight without/with packaging	0.174 kg/0.261 kg

Lutron and HomeWorks are registered trademarks and myRoom is a trademark of Lutron Electronics Co., Inc

---

## Lutron Contact Numbers

### **WORLD HEADQUARTERS USA**

**Lutron Electronics Co., Inc.**  
**7200 Suter Road**  
**Coopersburg, PA 18036-1299**  
TEL: +1.610.282.3800  
FAX: +1.610.282.1243  
Toll-Free: 1.888.LUTRON1  
Technical Support: 1.800.523.9466  
intsales@lutron.com

### **North & South America Technical Hotlines**

**USA, Canada, Caribbean:**  
1.800.523.9466  
**Mexico:**  
+1.888.235.2910  
**Central/South America:**  
+1.610.282.6701

### **EUROPEAN HEADQUARTERS United Kingdom**

**Lutron EA Ltd.**  
**6 Sovereign Close**  
**London, E1W 3JF United Kingdom**  
TEL: +44.(0)20.7702.0657  
FAX: +44.(0)20.7480.6899  
FREEPHONE (UK): 0800.282.107  
Technical Support: +44.(0)20.7680.4481  
lutronlondon@lutron.com

### **ASIAN HEADQUARTERS Singapore**

**Lutron GL Ltd.**  
**15 Hoe Chiang Road**  
**#07-03, Tower 15**  
**Singapore 089316**  
TEL: +65.6220.4666  
FAX: +65.6220.4333  
Technical Support: 800.120.4491  
lutronsea@lutron.com

### **Asia Technical Hotlines**

Northern China: 10.800.712.1536  
Southern China: 10.800.120.1536  
Hong Kong: 800.901.849  
Indonesia: 001.803.011.3994  
Japan: +81.3.5575.8411  
Macau: 0800.401  
Taiwan: 00.801.137.737  
Thailand: 001.800.120.665853  
Other Countries: +65.6220.4666