

## M•1400/M•1400i

■ The Mackie M•1400/M•1400i is a dual channel, high output power amplifier that incorporates a number of unique features including FR “Fast Recovery” design, high continuous-current output, built-in subwoofer crossovers, and a T-Design constant-gradient cooling tunnel for improved cooling efficiency and output device reliability.

■ The M•1400/M•1400i is rated at a continuous output of 250 watts per channel into 8Ω, 425 watts per channel into 4Ω and 630 watts into 2Ω. In bridge mode the M•1400/M•1400i is rated at 850 watts into 8Ω and 1260 watts into 4Ω. Variable low-cut filters on each channel, with a range from off to 170Hz, enable tighter bass response and a Constant Directivity Horn EQ improves high-frequency reproduction. The CD Horn EQ is 6 dB/octave and its “knee” position is sweepable from 2kHz to 6kHz. The built-in limiter is channel independent and helps eliminate clipping. Inputs are balanced/unbalanced 1/4" and XLR, and XLR thru connectors allow the full-range signal to be routed to another M•1400/M•1400i. Speaker connections on the M•1400 are Speakon® and binding posts, while speaker connections on the M•1400i are 1/4" and binding posts.

■ To effectively deal with clipping, an amplifier must be able to recover almost instantaneously. That is the definition of “Fast Recovery”. Rather than using negative feedback to help control clipping distortion, the M•1400/M•1400i employs a very sparse amount of negative feedback. The use of Baker Clamp circuits on the positive and negative voltage amp stages prevents saturation (and latching) during periods of overdrive. In addition, a transistor senses when the Baker Clamp is active and activates the internal limiting circuits. This results in no latching, instant recovery from overdriving the amp, and a superior sound.

(continued on page 8)

## RELATED PRODUCTS

M•800 Power Amplifier, 1202-VLZ PRO 12-Channel Mic/Line Mixer, 1402-VLZ PRO 14-Channel Mic/Line Mixer, 1604 VLZ PRO 16-Channel Mic/Line Mixer, 1642-VLZ PRO 16-Channel Mic/Line Mixer, SR24•4-VLZ PRO 24 Channel Mic/Line Mixer, SR32•4-VLZ PRO 32 Channel Mic/Line Mixer, CFX Series 12, 16, and 20 Channel Mic/Line Mixer w/Digital Effects, C300z 2-Way Loudspeaker, C200 2-Way Loudspeaker, SWA1501 and SWA1801 Active Subwoofers.

## High-Current Power Amplifier



## Features

- 1400 watts max, 1260 watts continuous @ 4 ohms bridged
- Ultra-low-noise/low-distortion design
- Fast Recovery circuitry reduces distortion at clipping
- Two 2nd order, 12 dB/octave, Bessel low-cut filters with variable frequency from Off to 170Hz
- Constant directivity horn EQ/Air EQ with variable frequency from 2kHz to 6kHz and on/off switch
- Limiter with on/off switch
- Balanced/unbalanced 1/4" and XLR inputs
- XLR thru outputs
- 1/4" jacks (M•1400i) or Speakon® (M•1400) connectors and 5-way binding post outputs (both models)
- Detented gain controls calibrated in dB and volts
- Signal present and OL LEDs
- Channel Status LEDs
- Superior T-Design cooling
- Five-year, limited warranty (U.S. only)

## Applications

- Live sound/music reinforcement for churches, clubs, schools, conference centers, hotels
- High level A/V playback
- Large speech systems

*CCI Solutions*  
be seen. be heard.

For more information or to order call  
**1-800-426-8664** or visit [www.ccisolutions.com](http://www.ccisolutions.com)

# M•1400/M•1400i High-Current Power Amplifier

## M•1400/1400i Specifications

### Maximum Power at 1% THD:

300 watts per channel into 8 ohms  
 500 watts per channel into 4 ohms  
 700 watts per channel into 2 ohms  
 1000 watts into 8 ohms bridged  
 1400 watts into 4 ohms bridged

### Continuous Sine Wave Average Output Power, both channels driven:

250 watts per channel into 8 ohms from 20Hz to 20kHz, with no more than 0.012% THD  
 425 watts per channel into 4 ohms from 20Hz to 20kHz, with no more than 0.025% THD  
 630 watts per channel into 2 ohms from 20Hz to 20kHz, with no more than 0.050% THD

### Bridged Mono Operation:

850 watts into 8 ohms from 20Hz to 20kHz, with no more than 0.025% THD  
 1260 watts into 4 ohms from 20Hz to 20kHz, with no more than 0.050% THD

### Power Bandwidth:

20Hz to 70kHz (+0, -3 dB)

### Frequency Response:

20Hz to 40kHz (+0, -1 dB)  
 10Hz to 70kHz (+0, -3 dB)

### Distortion:

THD, SMPTE IMD, TIM  
 <0.025% @ 8Ω  
 <0.050% @ 4Ω  
 <0.150% @ 2Ω

### Signal to Noise Ratio

>107 dB below rated power into 4 ohms

### Channel Separation:

>80 dB @ 1kHz

### Damping Factor:

>350 from 0 to 400Hz

### Input Impedance:

20kΩ balanced bridging

### Input Sensitivity:

1.23 (+4 dBu) for rated power into 4 ohms

### Voltage Gain:

30.25 dB (32.5V/V)

### Maximum Input Level:

9.75 volts (+22 dBu)

### Rise Time:

<4.4μs

### Slew Rate:

Voltage Slew Rate >50V/μs  
 >100V/μs bridged  
 Current Slew Rate >32A/μs at 2Ω

### CMRR:

>40 dB, 20Hz to 20kHz

### Transient Recovery:

1μs for 20 dB overdrive at 1kHz

### High Frequency Overload and Latching:

No latch up to any frequency or level

### Variable Low-Cut Filter:

10Hz (Off) to 170Hz, 2nd Order Bessel

### Subwoofer Low-Pass Filter:

Switched: 63Hz/125Hz, 3rd Order Bessel

### Constant Directivity High-Frequency Boost:

2kHz to 6kHz (+3 dB points)  
 6 dB/octave high-frequency shelving filter, (shelving occurs at approximately 30kHz)

### Limiter Section:

Complementary Positive and Negative Peak Detecting

### Indicators:

6 meter LEDs per channel  
 SIG (Signal Present), -20, -9, -6, -3, OL (Overload)  
 PROTECT LEDs, CH1 & 2  
 SHORT LEDs, CH1 & 2  
 TEMP STATUS  
 COLD/HOT LEDs

### Power Consumption:

65 watts (0.9A)	at idle
550 watts (6.7A)	with musical program fully loaded (4 ohms per side, or 8 ohms bridged)
900 watts (10.5A)	with musical program fully loaded (2 ohms per side, or 4 ohms bridged)
850 watts (9.6A)	at full power into 8 ohms (continuous sine wave)
1500 watts (15.6A)	at full power into 4 ohms (continuous sine wave)
2500 watts (24.8A)	at full power into 2 ohms (continuous sine wave)

(continued on page 3)

# M•1400/M•1400i

## High-Current Power Amplifier

### AC Line Power:

US (M•1400 and M•1400i)	120 VAC, 60Hz
Europe (M•1400 only)	240 VAC, 50/60Hz
Japan (M•1400 only)	100 VAC, 50/60Hz
Korea (M•1400 only)	220 VAC, 60Hz

### AC Drop-out Voltage:

At approximately 63% of rated line voltage

### Physical:

Height	3.50" (89 mm)
Width	19.00" (483 mm)
Depth	15.25" (387 mm)
Overall Depth	16.38" (416 mm)
Weight	36 lbs (16.3 kg)

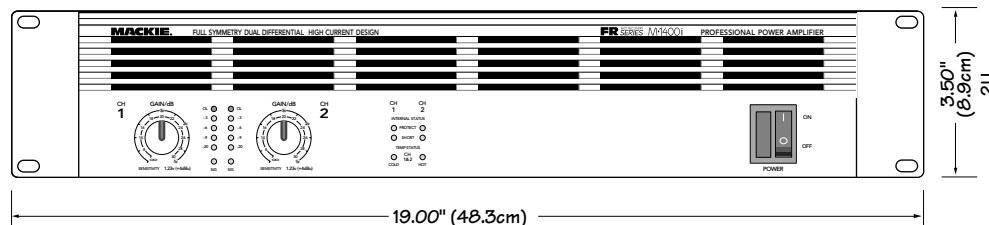
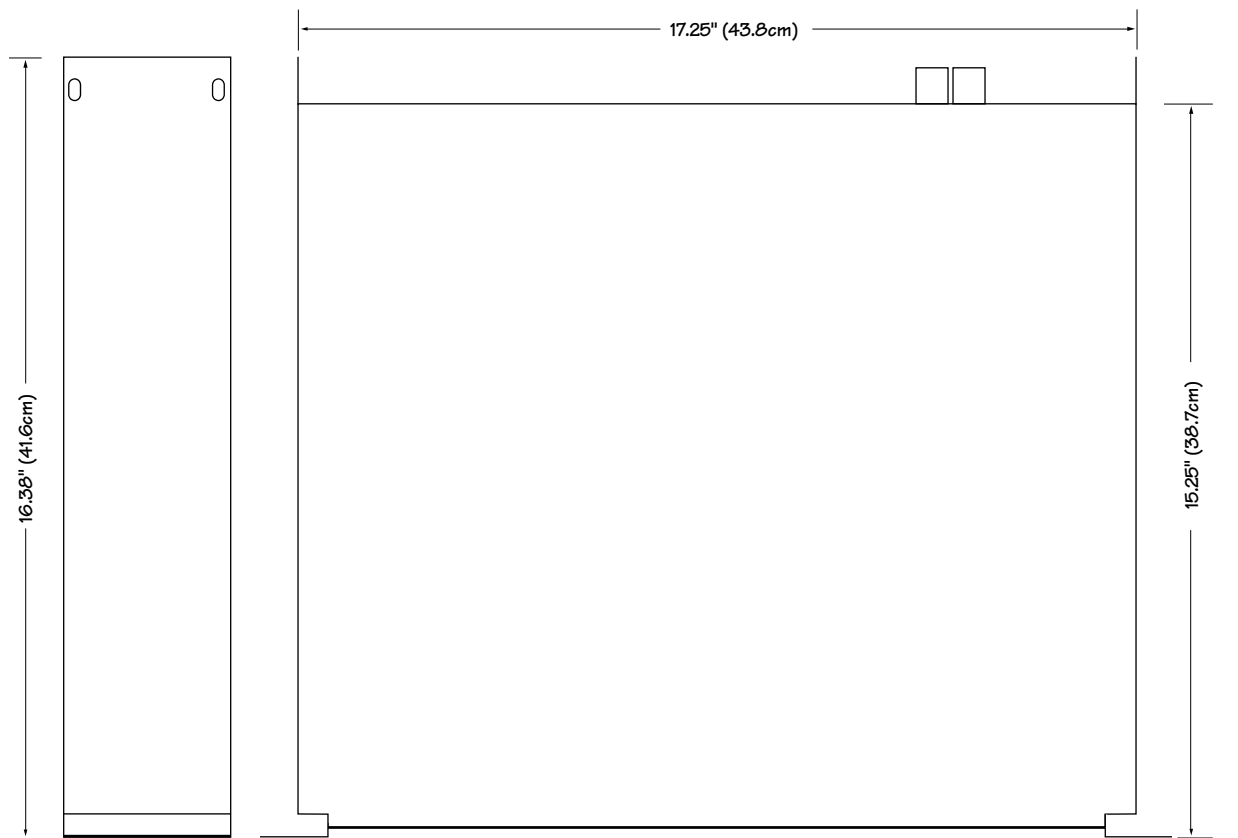

**MACKIE®**

*CCI Solutions*  
be seen. be heard.

For more information or to order call  
1-800-426-8664 or visit [www.ccisolutions.com](http://www.ccisolutions.com)

# M•1400/M•1400i High-Current Power Amplifier

## M•1400/M•1400i Block Diagram

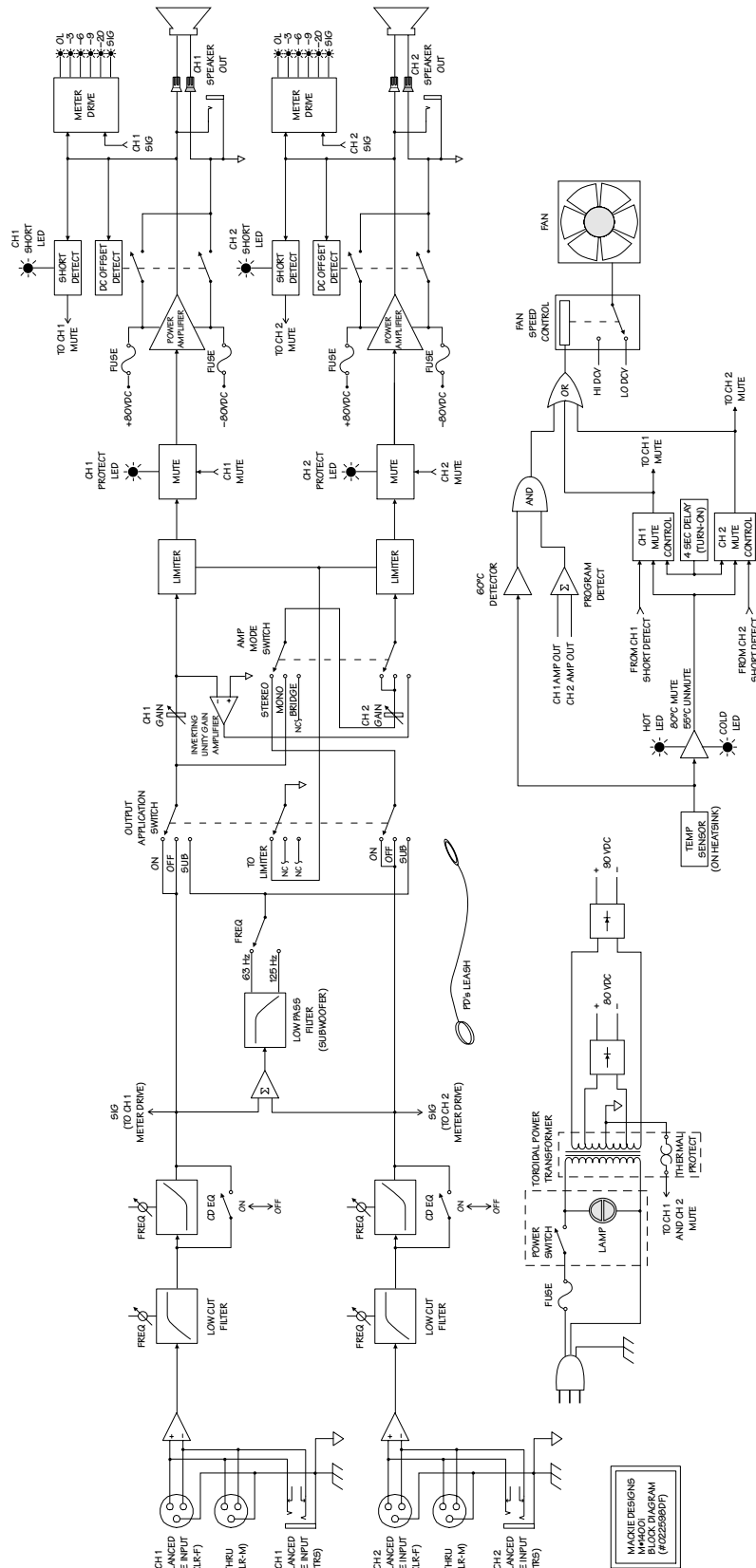

**MACKIE®**

*CCI Solutions*  
be seen. be heard.

For more information or to order call  
1-800-426-8664 or visit [www.ccisolutions.com](http://www.ccisolutions.com)

# M•1400/M•1400i

## High-Current Power Amplifier

### M•1400/M•1400i Front Panel

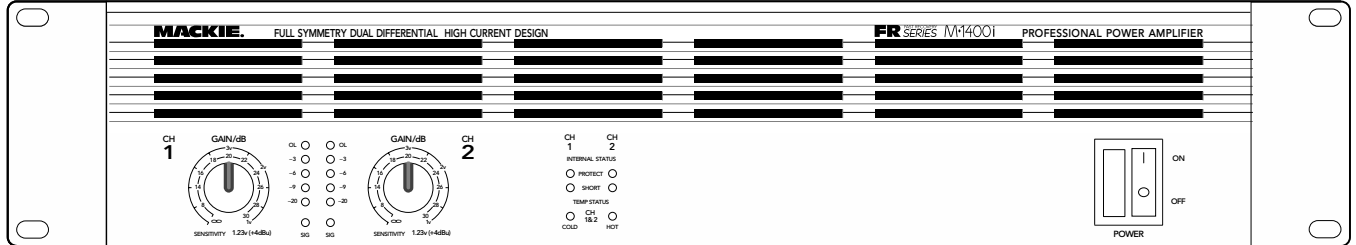

### M•1400i Rear Panel

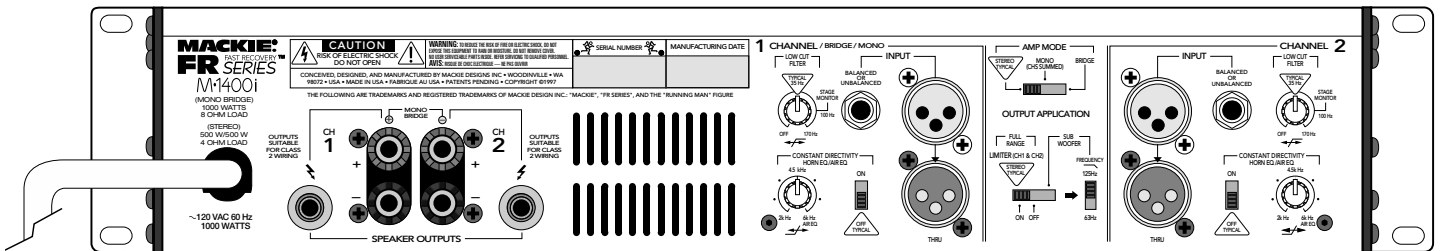

### M•1400 Rear Panel

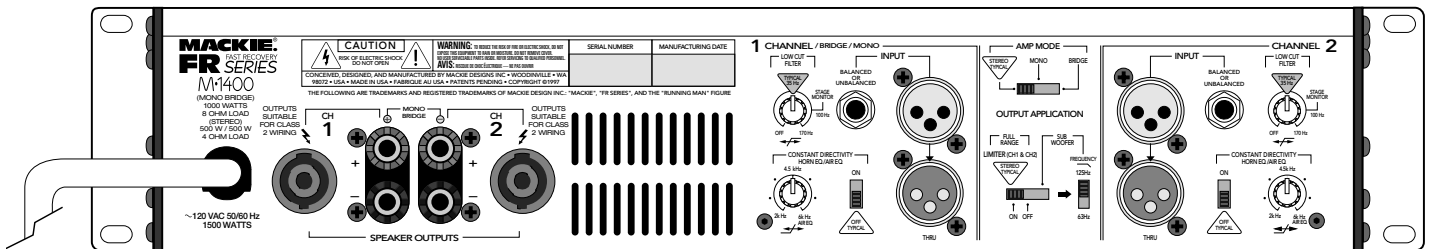

*CCI Solutions*  
be seen. be heard.

For more information or to order call

1-800-426-8664 or visit [www.ccisolutions.com](http://www.ccisolutions.com)

**MACKIE**®