

■ **KITCHEN KNIGHT® II:
RESTAURANT
FIRE SUPPRESSION
SYSTEM –
PCL-160/300/460/600**



TECHNICAL MANUAL

- **COMPONENTS**
- **DESIGN**
- **INSTALLATION**
- **MAINTENANCE**
- **RECHARGE**



A Tyco International Company

*One Stanton Street
Marinette, WI 54143-2542
www.pyrochem.com*

BULLETIN

Bulletin No. 2430

DATE: February 28, 2012
TO: All Authorized PYRO-CHEM Restaurant System Distributors and OEMs
FROM: Product Management – Restaurant Systems
SUBJECT: Model 691 Dual Lift Henny Penny Pressure Fryer Protection

We are pleased to inform you that the Model 691 Dual Lift Henny Penny Pressure Fryer has been added to the UL Listed fryers that utilize the KITCHEN KNIGHT II Restaurant Fire Suppression System for appliance protection.

The Henny Penny Pressure Fryer protection limitations must be followed as outlined in the PYRO-CHEM KITCHEN KNIGHT II Restaurant Fire Suppression Technical Manual (Part No. 551274-05). These limitations can be found in the Design section, Page 3-13.2.

The information contained in this bulletin serves as a supplement to the KITCHEN KNIGHT II system manual, and the Model 691 Dual Lift Henny Penny Pressure Fryer will be added to the manual at the next issue date.

Should you have questions pertaining to this bulletin, please contact Technical Services as noted below.

UL EX 3830

Main Telephone Numbers: 1-800-526-1079 or 1-715-732-3465
Customer Services: Press 2 • Technical Services: Press 4 • Training Services: Press 6 • Quality Assurance: Press 8
Literature Fax Orders: 1-877-329-7976 or 1-715-732-3569



A Tyco International Company
One Stanton Street
Marinette, WI 54143-2542
www.pyrochem.com

BULLETIN

Bulletin No. 2421

DATE: October 20, 2011
TO: To All Authorized PYRO-CHEM Restaurant Distributors
FROM: Product Management, Restaurant Systems
SUBJECT: KITCHEN KNIGHT II Fire Suppression Technical Manual Changes

This bulletin is to inform you of some modifications to the KITCHEN KNIGHT II Fire Suppression Technical Manual that have been made to comply with the recent changes to UL 1254 Pre-Engineered Dry Chemical Extinguishing System Units Standard.

Although the UL 1254 Pre-Engineered Dry Chemical Extinguishing System Units Standard title indicates it is for Dry Chemical Systems, it is used to cover the construction and operation of all fixed pre-engineered wet chemical fire suppression systems as well.

The revision noted below will be included with the next revision of the KITCHEN KNIGHT II Fire Suppression Technical Manual (PN551274-5) to meet the newest UL 1254 requirements.

Chapter 6 – System Recharge: page 6-2

NOTE – The pressure gauge attached to the tank valve shall not be used to determine when the charging pressure has been reached. A calibrated external gauge must be used.

NOTE – A pressure regulator shall be used for charging the tank assembly when the pressure source is higher than the tank-rated operating pressure of 225 psi (15.5 bar).

Questions pertaining to this bulletin should be directed to Technical Services as listed below.

ULEX 3830

Main Telephone Numbers: 1-800-526-1079 or 1-715-732-3465
Customer Services: Press 2 • Technical Services: Press 4 • Training Services: Press 6 • Quality Assurance: Press 8
Literature Fax Orders: 1-877-329-7976 or 1-715-732-3569



BULLETIN

by Tyco Fire Suppression & Building Products

One Stanton Street
Marinette, WI 54143-2542
www.pyrochem.com

Bulletin No. 2386

DATE: March 19, 2010
TO: All KITCHEN KNIGHT® II System Distributors and OEM's
FROM: Product Management – Restaurant Systems
SUBJECT: Bakers Pride Broiler with Smoker Box – UL-Listed Protection

We are pleased to announce an appliance-specific UL Listing for the KITCHEN KNIGHT II Restaurant Fire Suppression Systems when protecting the following Bakers Pride Broilers: CH6, CH8, CH10, XX6, XX8, XX10 with Smoker Box and Chip Holders.

All listed models are protected within the parameters indicated in this bulletin. The information in this bulletin will serve as a manual supplement for the KITCHEN KNIGHT II Fire Suppression System Technical Manual PN 551274(5) dated September 2009 and will be added to the manual at next reprint.

The following nozzle position and coverage limitations must be followed:

- Nozzle Quantity Three
- Nozzle Type 2H
- Nozzle Height 33 in. (83.8 cm) to 35 in. (88.9 cm) above the hazard surface
- Nozzle Location Each nozzle is to protect 1/3 of the cooking area and located in the horizontal center of the respective cooking area; 1 in. (2.5 cm) forward of the longitudinal center line of the cooking area.
- Nozzle Aiming Point Horizontal center of the respective cooking area, 1 in. (2.5 cm) forward of the longitudinal center line of the cooking area.

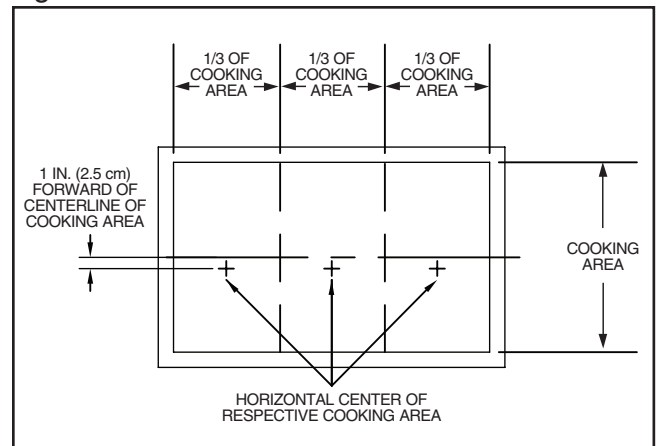
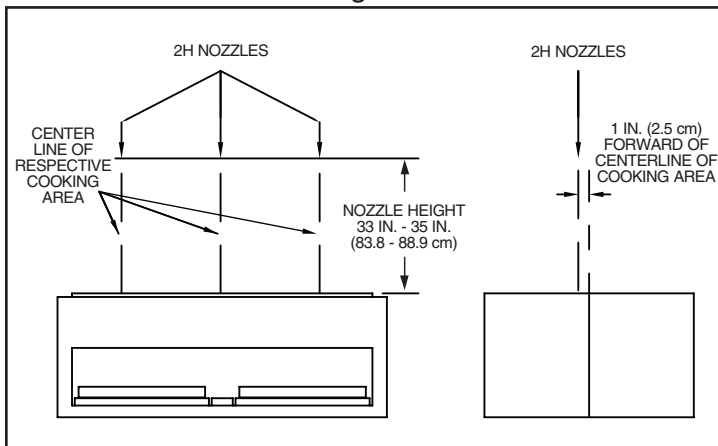

Smoker Box and Chip Holders cannot exceed logs 4 in. (10 cm) in diameter and a maximum allowable wood depth of 4 in. (10 cm).

If you should have any questions regarding this bulletin please contact your US Standard Products Manager or International Area Manager; or call Technical Services as indicated below.

UL EX3830



One Stanton Street
Marinette, WI 54143-2542
800-526-1079
715-732-3465
www.pyrochem.com

Bulletin No. 2346

DATE: February 27, 2009
TO: PYRO-CHEM® sRestaurant System Distributors and OEM's
FROM: Product Management – Restaurant Systems
SUBJECT: KITCHEN KNIGHT® II Protection of Nieco Overhead Chain-Broiler

We are pleased to announce appliance-specific fire protection of the Nieco Broiler Model MBP 84 (with catalyst) for low profile applications using the KITCHEN KNIGHT II system. This protection scheme has been added to our UL 300 appliance-specific protection approvals based on the coverage established for the Nieco Model 94 Broiler.

The following nozzle positioning and coverage limitations must be followed:

Nieco Broiler – Model MPB 84 with Catalyst ONLY

- Nozzle Type 2L
- Nozzle Quantity One
- Nozzle Height 20 in. (508 mm)
- Nozzle Location 6.5 in (165 mm) from any edge of the appliance top
- Nozzle Direction Aim at center of opening

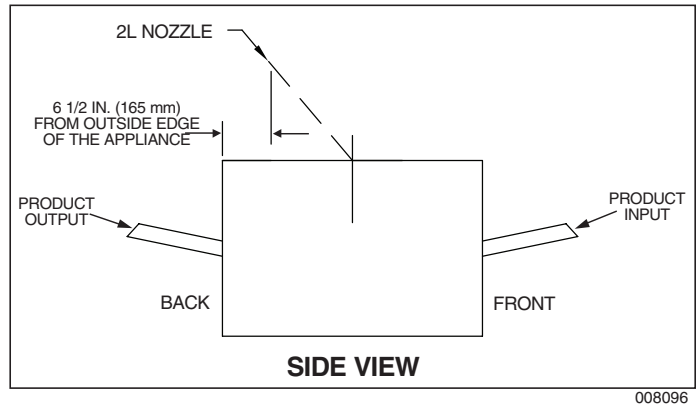
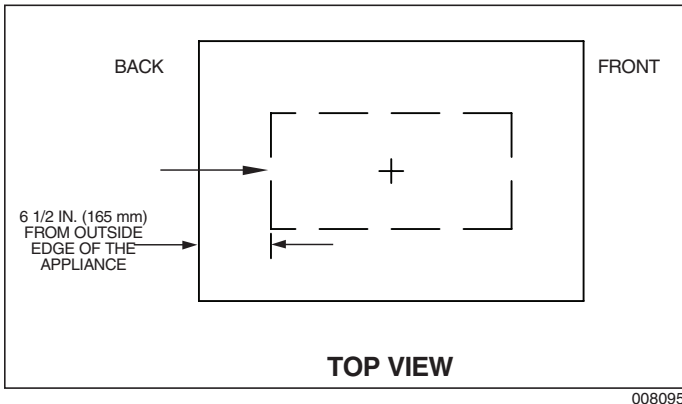

Please note that in applications that cannot utilize an overhead application, standard chain broiler protection is acceptable using the 1L Nozzle installed at the opening.

If you should have any questions pertaining to this bulletin please contact your Territory Sales Manager or call Technical Services at 1-800-526-1079 or 1-715-732-3456.

TABLE OF CONTENTS

<u>Page</u>	<u>Subject</u>	<u>Revision</u>	<u>Date</u>	<u>Page</u>	<u>Subject</u>	<u>Revision</u>	<u>Date</u>
<u>Chapter 1 – General Information</u>				3-5	Fryers	5	12-1-09
1-1	Introduction	5	12-1-09		Range (Small)		
<u>Chapter 2 – Components</u>				3-6	Range (Small) (cont.)	5	12-1-09
2-1	Cylinders & Valve	5	12-1-09		High-Proximity Backshelf		
	Wet Valve Rebuilding Equipment			3-7	Range (Large)	3	3-1-06
	Wet Valve Seal Rebuilding Kit				Nozzle Positioning Chart		
2-2	Pressure Regulator Assembly	4	3-1-06	3-8	Nozzle Positioning Chart (cont.)	3	3-1-06
	Pressure Regulator Rebuilding Kit				Small Wok		
	Model VT-1 Tool			3-9	Large Wok	3	3-1-06
	Cylinder Bracketing				Small Griddle		
	Extinguishing Agent			3-10	Large Griddle	4	12-1-09
2-3	MCH3 Mechanical Control Head	3	12-1-09		Radiant/Electric Char-Broiler		
	ECH3 Electrical Control Head			3-11	Radiant/Electric Char-Broiler	4	12-1-09
	NMCH3 Mechanical Control Head				Lava Rock Char-Broiler		
2-4	EN-MCU3 Enclosure	4	12-1-09		Natural Charcoal Char-Broiler		
	EN-S Enclosure			3-12	Mesquite Char-Broiler	4	12-1-09
	16 Gram CO ₂ Cartridge				Salamander Broiler		
	MB-P2 Mounting Bracket				Upright/Salamander Broiler		
	Pneumatic Actuating Cylinders			3-13	Chain Broiler	3	3-1-06
	PAC-10				Tilt Skillet/Braising Pan		
2-5	Detection Equipment	3	3-1-06	3-13.1	Henny Penny Fryer – Model 690, 691, 692	New	12-1-09
	Model FLK-1			3-13.2	Henny Penny Fryer – Model 580, 581, 582, 590, 591, 592, 680, 682	New	12-1-09
	Model FLK-1A			3-13.3	Nieco Broiler – Model MPB-84	New	12-1-09
	Model FLH-1				Nieco Broiler – Model JF94E		
2-6	Fusible Links	5	12-1-09	3-13.4	Blank	New	12-1-09
	Thermal Detectors			3-14	Fryer – Multiple Nozzle Protection	5	12-1-09
	Flexible Conduit				Piping Limitations		
2-7	RPS-M – Remote Pull Station	5	12-1-09	3-15	General Piping Requirements	3	3-1-06
	Quik-Seal Adaptor				Design Steps		
	Compression-Seal Adaptor			3-16	Design Steps (cont.)	3	3-1-06
	Hood Seal Adaptor Assembly			3-17	Design Steps (cont.)	2	3-1-06
2-8	Gas Shut-off Valves	5	12-1-09	3-18	Design Steps (cont.)	2	3-1-06
	GV Shut-off Valves			3-19	Detector Placement	3	12-1-09
	EGVSO Gas Shut-off Valves				Exhaust Duct(s)		
2-9	Corner Pulleys	3	12-1-09		Electrostatic Precipitator		
	SBP-1 Corner Pulley			3-20	Cooking Appliance(s)	2	12-1-09
	CBP-1 Corner Pulley			<u>Chapter 4 – System Installation</u>			
	WBP-1 Corner Pulley			4-1	General	4	12-1-09
	Tee Pulley				Cylinder Installation		
	Wire Rope				Control Head Installation		
2-10	Electrical Switches	5	12-1-09		Single Cylinder Installation		
	SM-120 Solenoid Monitor			4-2	Multiple Cylinder Installation	3	3-1-06
	Pipe and Fittings			4-3	Multiple Cylinder Installation (cont.)	3	3-1-06
2-11	Agent Distribution Hose and Restraining Cable Kit	3	12-1-09	4-4	Detector Installation	4	12-1-09
	Stainless Steel Actuation Hose				Fusible Link Detection		
	Nozzles			4-5	Fusible Links Without Hangers	3	3-1-06
	Rubber Blow-Off Caps			4-6	Fusible Links With Link Hangers	4	12-1-09
	Swivel Adaptor				Thermal Detection		
2-12	Nozzle Aiming Device	3	12-1-09	4-7	Setting The Control Head	4	12-1-09
2-13	Components List	New	12-1-09		MCH3/NMCH3 Control Head		
2-14	Components List (cont.)	New	12-1-09		ECH3 Control Head		
<u>Chapter 3 – System Design</u>				4-8	Solenoid Monitor Installation	5	12-1-09
3-1	General	5	12-1-09		In Detection Circuit		
3-1	Nozzle Coverage and Placement			4-9	Solenoid Monitor When Used As – A Reset Relay	4	12-1-09
	Duct Protection				Remote Pull Station Installation		
3-2	Modularizing Duct	4	12-1-09	4-10	Remote Pull Station Installation (cont.)	4	12-1-09
3-3	Transition Ducts	4	12-1-09	4-11	Gas Shut-off Valve Installation	4	12-1-09
	Electrostatic Precipitator				Mechanical Gas Shut-off – Valve Installation		
	Plenum Protection						
3-4	Appliance Protection	3	3-1-06				
	Design Chart						

► Indicates added or revised information.

■ Indicates change in page sequence.

TABLE OF CONTENTS

<u>Page</u>	<u>Subject</u>	<u>Revision</u>	<u>Date</u>	<u>Page</u>	<u>Subject</u>	<u>Revision</u>	<u>Date</u>
4-12	Electrical Gas Shut-off Valve – Installation	4	12-1-09	4-29	Flexible Conduit Splicing (cont.)	New	12-1-09
	Pulley Tee Installation			4-30	Flexible Conduit Splicing (cont.)	New	12-1-09
	Electrical Switch Installation				Testing Pull Station/Mechanical Gas Valve		
4-13	Electrical Switch Installation (cont.)	3	12-1-09		<u>Chapter 5 – System Maintenance</u>		
	Pipe and Nozzle Installation			5-1	General	5	12-1-09
4-14	Pipe and Nozzle Installation (cont.)	5	12-1-09		Semi-Annual Maintenance		
	Installation Instructions for Castered/Moveable Equipment Using Agent Distribution Hose			5-2	Annual Maintenance		
	Critical Installation Requirements				12-Year Maintenance	2	12-1-09
	Agent Distribution Hose Installation				<u>Chapter 6 – System Recharge</u>		
	General Requirements			6-1	General	5	12-1-09
4-14.1	Installation Requirements	New	12-1-09		System Cleanup		
	Restraining Cable Installation				System Recharge		
4-14.2	Restraining Cable Installation (cont.)	New	12-1-09	6-2	System Recharge (cont.)	3	3-1-06
4-14.3	Final Installation Guidelines and Checkout Procedures	New	12-1-09	6-3	Notes	1	3-1-06
	Agent Distribution Hose/Restraining Cable Six Month Maintenance			6-4	Notes	1	3-1-06
4-14.4	Blank	New	12-1-09				
4-15	System Checkout After Installation	4	12-1-09				
	Model MCH3/NMCH3 – Mechanical Control Head						
	Model ECH3-24/120 – Electrical Control Head						
4-16	Enclosure Installation Instructions	5	12-1-09				
	Enclosure Mounting						
4-17	Fusible Link Detector Installation	3	12-1-09				
	Setting the EN-MCU3						
	Remote Pull Station Installation						
4-18	Gas Shut-off Valve Installation	5	12-1-09				
	Electrical Switch Installation						
4-19	Electrical Switch Installation (cont.)	New	12-1-09				
	Cylinder Installation						
	Single Cylinder Installation						
	Multiple Cylinder Installation						
	System Checkout After Installation						
4-20	System Checkout After Installation (cont.)	New	12-1-09				
4-21	Flexible Conduit Installation	New	12-1-09				
	Design Requirements						
	Installation Requirements						
4-22	Installation Requirements (cont.)	New	12-1-09				
	Connecting Flexible Conduit to Control Head, Electrical Box, Pull Station, or Mechanical Gas Valve						
4-23	Connecting Flexible Conduit to Control Head, Electrical Box, Pull Station, or Mechanical Gas Valve (cont.)	New	12-1-09				
4-24	Connecting Flexible Conduit to Pulley Elbows, Pulley Tees, or Union Fittings	New	12-1-09				
4-25	Connecting Flexible Conduit to Pulley Elbows, Pulley Tees, or Union Fittings (cont.)	New	12-1-09				
4-26	Installing Flexible Conduit Through a Conduit Offset	New	12-1-09				
4-27	Installing Flexible Conduit Through a Conduit Offset (cont.)	New	12-1-09				
4-28	Installing Flexible Conduit Through a Conduit Offset (cont.)	New	12-1-09				
	Flexible Conduit Splicing						

ULEX 3830

December 1, 2009

REV. 5

- ▶ Indicates added or revised information.
- Indicates change in page sequence.

CHAPTER I

GENERAL INFORMATION

INTRODUCTION

► This manual is intended for use with PYRO-CHEM® KITCHEN KNIGHT® II Restaurant Fire Suppression Systems. Those who install, operate, recharge, or maintain these fire suppression systems should read this entire manual. Specific sections will be of particular interest depending upon one's responsibilities.

Design, installation, recharge, and maintenance of the system must conform to the limitations detailed in this manual and performed by an individual who attended a PYRO-CHEM training program and became trained to install, recharge, design, and maintain the PYRO-CHEM system.

Fire suppression systems are mechanical devices. They need periodic care. Maintenance is a vital step in the performance of your fire suppression system. As such, it must be performed in accordance with NFPA 96 (Standard for the Installation of Equipment for the Removal of Smoke and Grease-Laden Vapors from Commercial Cooking Equipment) and NFPA 17A (Standard on Wet Chemical Extinguishing Systems) by an authorized PYRO-CHEM distributor. To provide maximum assurance that the fire suppression system will operate effectively and safely, maintenance must be conducted at six-month intervals, or earlier if the situation dictates. Twelve-year maintenance must include agent tank hydrostatic testing.

► The PYRO-CHEM KITCHEN KNIGHT II Pre-Engineered System utilizes a wet chemical agent specifically designed to suppress restaurant cooking area fires. The system provides automatic actuation and can be manually actuated through a remote mechanical pull station. Upon actuation, the system discharges a pre-determined amount of agent to the duct, plenum, and cooking appliances. The agent acts to suppress fires in three ways:

1. The chemical chain reaction causing combustion is interrupted by both the agent itself and the resulting steam formation.
2. The agent cools the fire bringing it below auto-ignition temperature.
3. The agent reacts with hot grease forming a soap-like layer (saponification) that helps prevent the escape of combustible vapors, thus preventing re-ignition.

The shutdown of all sources of fuel and electric power that produce heat to all equipment protected by the system is required upon system actuation. Make up or supply air fans, integral to the exhaust hood(s) being protected, shall be shut down upon system actuation. Exhaust fan(s) in the ventilation system should remain on during system discharge as they assist the dispersion of chemical through the ventilating system. The system is UL Listed with or without exhaust fan shutdown.

The KITCHEN KNIGHT II and the KITCHEN KNIGHT Restaurant Fire Suppression System are compatible as long as separate installation guidelines are followed per each system design manual. Exception: The actuation limitations for the KITCHEN KNIGHT II system may be utilized for the KITCHEN KNIGHT system. Also, control heads, prior to Model No. 3, may be utilized on KITCHEN KNIGHT II systems, provided that the limitations used with those control heads are followed.

Temperature Limitations

The operating temperature range of the PYRO-CHEM KITCHEN KNIGHT II System is 32° F (0° C) minimum to 120° F (49° C) maximum.

UL Listing

The PYRO-CHEM KITCHEN KNIGHT II Restaurant Fire Suppression System has been tested to the UL Standard for [Fire Extinguishing Systems For Protection of Restaurant Cooking Areas, UL300](#) and Listed by Underwriters Laboratories, Inc.

ULC Listing

The PYRO-CHEM KITCHEN KNIGHT II Restaurant Fire Suppression System is listed by Underwriters Laboratories of Canada (ULC). The ULC Listing No. is CEX812.

MEA Approval

The PYRO-CHEM KITCHEN KNIGHT II Restaurant Fire Suppression System has been approved for use by MEA (Material and Equipment Acceptance Division) for New York City. The MEA Certification No. is 249-03-E.

CHAPTER II COMPONENTS

CYLINDERS & VALVE

The PYRO-CHEM KITCHEN KNIGHT II System has available four different size cylinders: Models PCL-160 (P/N 553163), PCL-300 (P/N 551194), PCL-460 (P/N 551193), and PCL-600 (P/N 551196). Cylinder sizes are expressed in terms of extinguishing agent capacity (i.e., the PCL-300 uses 3.0 gallons (11.4 L) of extinguishing agent). The cylinder is manufactured, tested, and meets DOT requirements. Cylinders come pre-filled with extinguishing agent and are charged with dry nitrogen to a pressure of 225 psig @ 70° F (15.5 bar @ 21 °C). Cylinder and valve assembly dimensions are shown in **Figure 2-1a**.

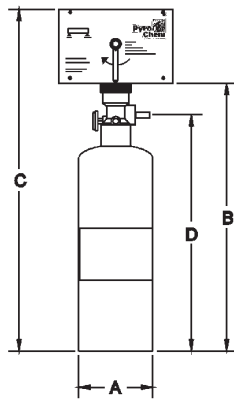

Model No.	A in. (cm)	B in. (cm)	C in. (cm)	D in. (cm)	Max. Flow Point Capacity	Weight lb (kg)	Mounting Bracket Used
PCL-160	8.00 (20.3)	17.75 (45.1)	23.50 (59.7)	15.44 (39.2)	5	34 (15)	MB-15
PCL-300	8.00 (20.3)	25.06 (63.7)	30.81 (78.3)	22.75 (57.8)	10	53 (24)	MB-15
PCL-460	10.00 (25.4)	25.06 (63.7)	30.81 (78.3)	22.75 (57.8)	15	83 (37.7)	MB-15
PCL-600	10.00 (25.4)	35.81 (91)	41.56 (105.4)	33.50 (85.1)	20	108 (48.9)	MB-1

Figure 2-1a. Cylinder and Valve Assemblies.

002841PC

All cylinders utilize the same wet valve assembly (P/N 551175). The wet valve assembly is a pressure sealed poppet type valve designed to provide rapid actuation and discharge of agent. See **Figure 2-1b**.

Item	Part No.	Description	Item	Part No.	Description
1		Valve Body	8	550386	Shrader Valve Ass'y
2	550705	Conical Spring	9	550714	Valve Cap O-Ring
3	550707	Piston	10	550715	Piston O-Ring
4	550716	Neck O-Ring	11	550989	Valve Stem
5	551236	Pressure Gauge	12	551256	Pressure Regulator
6	550028	Stem O-Ring	13	551261	Seal
7	550802	Wet Valve Adaptor	14	17851	6-32x3/8 Screw

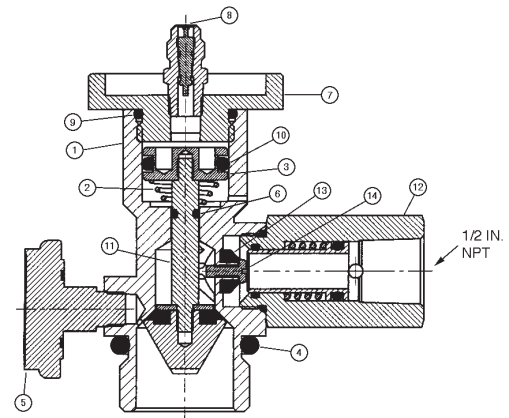

Figure 2-1b. Wet Valve Cross Section.

006212PC

WET VALVE REBUILDING EQUIPMENT

Wet Valve Seal Rebuilding Kit (P/N 550698)

After system discharge, the valve assembly must be rebuilt to ensure proper future operation. The Wet Valve Seal Rebuilding Kit (P/N 550698) should be used. It includes all components necessary to properly rebuild the valve. See **Figure 2-2a**.

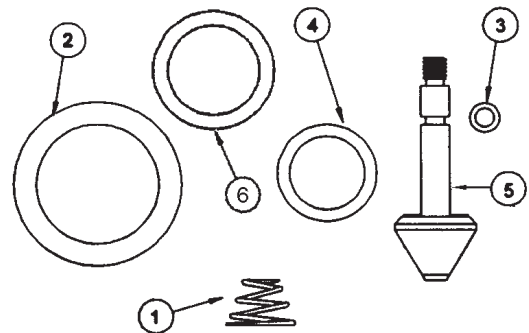

Figure 2-2a. Wet Valve Seal Rebuilding Kit.

002906PC

Item	Part Number	Description
1	550705	Conical Spring
2	550716	Neck O-Ring
3	550028	Stem O-Ring
4	550715	Piston O-Ring
5	550989	Valve Stem
6	550714	Valve Cap O-Ring

Pressure Regulator Assembly (P/N 550985)

The pressure regulator assembly is available if the complete regulator requires replacement (i.e., possible thread damage).

Pressure Regulator Rebuilding Kit (P/N 551061)

After system discharge, the pressure regulator must be rebuilt to ensure proper future operation. The rebuilding kit (P/N 551061) should be used. It includes all components and instructions necessary to properly rebuild the regulator. See **Figure 2-2b**.

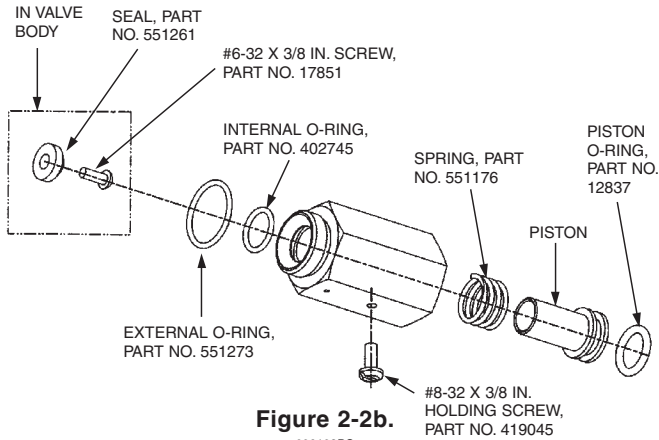

Figure 2-2b.
 006103PC

Model VT-1 (P/N 550788)

The Model VT-1 wet valve tool is designed to facilitate the rebuilding of the wet valve assembly. It should be used to hold the wet valve piston while unscrewing the cap and stem assembly. See **Figure 2-2c**.

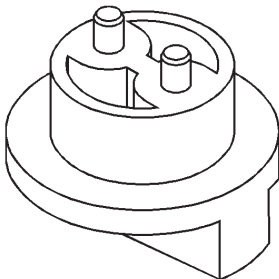

Figure 2-2c. Model VT-1 Wet Valve Tool.
 002907PC

CYLINDER BRACKETING

Vertical bracketing of the PCL-160, PCL-300 and PCL-460 is provided by the Model MB-15 bracket kit (P/N 550054). Vertical bracketing of the PCL-600 is provided by the Model MB-1 bracket kit (P/N 550053). These kits must be ordered separately with each cylinder/valve assembly. Cylinder installation instructions are provided in the installation section of this manual.

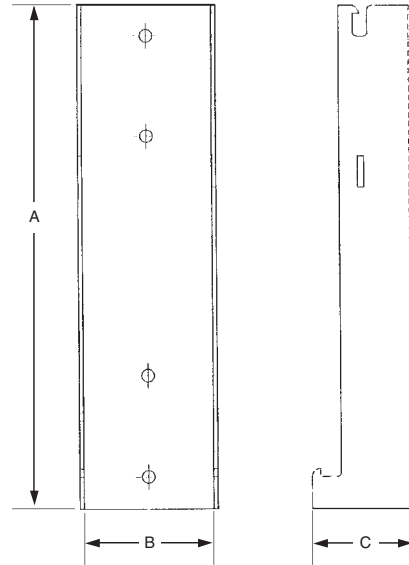

Figure 2-3.
 006842PC

Model No.	A	B	C
MB-15	15.69 in. (39.9 cm)	4.0 in. (10.2 cm)	3.13 in. (7.9 cm)
MB-1	20.44 in. (51.9 cm)	4.0 in. (10.2 cm)	2.13 in. (5.4 cm)

EXTINGUISHING AGENT

The agent used in PYRO-CHEM KITCHEN KNIGHT II Systems is a potassium carbonate based solution that is extremely effective for grease-related kitchen fires. This agent is available for cylinder recharging in 1.6 Gallon and 3.0 Gallon containers. For MSDS information, contact PYRO-CHEM at 800-526-1079 or 715-732-3465 or www.pyrochem.com.

1.6 Gallon Shipping Assembly – P/N 553176

3.0 Gallon Shipping Assembly – P/N 551188

CAUTION

Precautions must be taken when handling and transferring wet agents as they are caustic in nature. Goggles must be worn at all times. If any agent gets into the eyes, they should be flushed with clean water for 15 minutes and a physician contacted. If any agent contacts the skin, it should be flushed with cold water to prevent irritation. The agent is electrically conductive. Care must be taken to thoroughly clean up any agent discharged around electrical appliances before turning the power on.

After system discharge, agent must be cleaned up immediately with hot, soapy water to prevent corrosion of effected surfaces.

MODEL MCH3 - MECHANICAL CONTROL HEAD (P/N 551200)

The Model MCH3 mechanical control head is a fully mechanical control head which can be connected to the PCL-160/300/460/600 cylinder valve. This control head will support a fusible link detection system, a remote mechanical pull station (Model RPS-M), and a mechanical or electric gas shut-off valve. A micro electric switch (Model MS-SPDT, MS-DPDT, MS-3PDT, or MS-4PDT) can be ordered separately and field installed. It is equipped with a local manual control handle that allows for mechanical system actuation. Operation of the local manual control requires removing the pull pin and rotating the handle clockwise. The Model MCH3 control head can actuate a maximum of five (5) cylinders with the 16 gram CO₂ cartridge. See **Figure 2-4**.

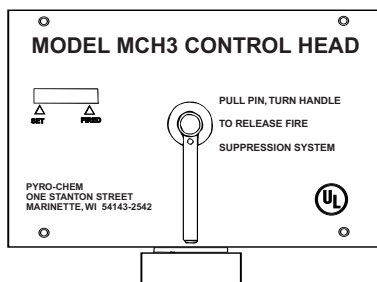

Figure 2-4. Mechanical Control Head.
004790PC

MODEL ECH3 – ELECTRIC CONTROL HEAD

The Model ECH3 electric control head is an electrically operated control head which can be connected to the PCL-160/300/460/600 cylinder valve. This control head will support an electric thermal detection system, a remote mechanical pull station (Model RPS-M), and an electric gas shut-off valve. It will not support a fusible link detection system. An electric (snap-action) switch (Model MS-DPDT) is included.

The Model ECH3 control head is available in both 120 VAC (Model ECH3-120, P/N 551202) and 24 VDC (Model ECH3-24, P/N 551201). It is equipped with a local manual control handle that allows for mechanical system actuation. Operation of the local manual control requires removing the pull pin and rotating the handle clockwise. The Model ECH3 control head can actuate a maximum of five (5) cylinders with the 16 gram CO₂ cartridge. See **Figure 2-5**.

► **Note:** When utilizing electric detection, it is recommended that the Model ECH3-24 electric control head be used with either the AUTOPULSE 542R Control Panel (Part No. 433607) or the AUTOPULSE Z-10 Control Panel (Part No. 430525). If the ECH3-120 control head is to be utilized, it must be used with Solenoid Monitor, Model SM-120 (Part No. 550303), along with a UL Listed 1A, 120VAC power supply (by others), in accordance with NFPA 17A, NFPA 96, and the local authority having jurisdiction.

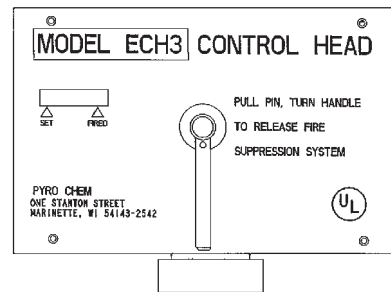

Figure 2-5. Electric Control Head.
004789PC

MODEL NMCH3 - MECHANICAL CONTROL HEAD (P/N 551203)

The Model NMCH3 Mechanical Control Head is a fully mechanical control head which can be connected to the PCL-160/300/460/600 cylinder valve. This control head will support a fusible link detection system, a remote mechanical pull station (Model RPS-M), and a mechanical or electric gas shut-off valve. An electrical (snap-action) switch (Model MS-SPDT, MS-DPDT, MS-3PDT, or MS-4PDT) can be ordered separately and field installed. There is no local manual actuation for the Model NMCH. The Model NMCH3 control head can actuate a maximum of five (5) cylinders with the 16 gram CO₂ cartridge.

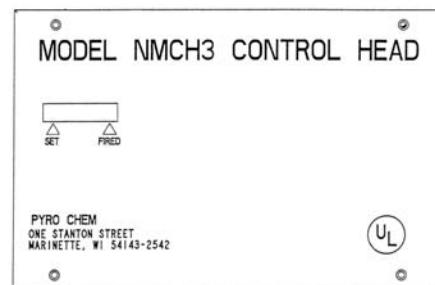

Figure 2-5.1. Mechanical Control Head.
006843PC

MODEL EN-MCU3 ENCLOSURE (P/N 551208)

The Model EN-MCU3 Enclosure is used for vertical mounting of a single PCL-160, PCL-300 or PCL-460. The EN-MCU3 also includes a mechanical control unit, eliminating the need for a Model MCH3 Control Head. See **Figure 2-6**. *The PCL-600 cannot be mounted in an EN-MCU3.*

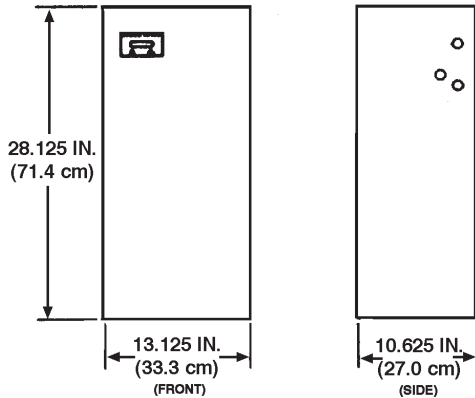

Figure 2-6. Model EN-MCU3 Enclosure.

002845PC

MODEL EN-S ENCLOSURE (P/N 550966)

The Model EN-S Enclosure is used for vertical mounting of a single PCL-160, PCL-300 or PCL-460 when it is used as a secondary agent cylinder in a system. Dimensions are the same as the Model EN-MCU3 enclosure (see Figure 2-6). The EN-S has no control mechanism, and must be used in conjunction with a Model EN-MCU3 Enclosure or a Model MCH3/ECH3 Control Head. *The PCL-600 cannot be mounted in an EN-S.*

▶ 16 GRAM CO₂ CARTRIDGE (P/N 551059)

The 16 Gram CO₂ Cartridge is required to pneumatically actuate the tank valve. The cartridge is installed in the control head on top of the tank valves. The cartridge shipping assembly contains 6 cartridges.

MODEL MB-P2 – CONTROL HEAD MOUNTING BRACKET (P/N 550853)

The Model MB-P2 mounting bracket must be used to mount the Model MCH3, NMCH3, or ECH3 control heads if the control head is not mounted directly on a cylinder valve. See **Figure 2-7**.

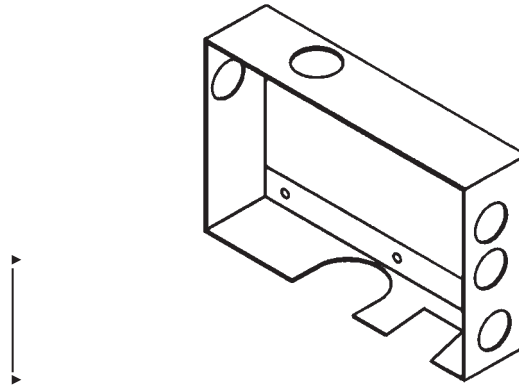

Figure 2-7. Model MB-P2 - Control Head Mounting Bracket.

002846PC

PNEUMATIC ACTUATING CYLINDERS

Model PAC-10 (P/N 550104)

The Model PAC-10 is a pneumatic actuating cylinder that can actuate a maximum of ten (10) agent cylinders simultaneously. The Model PAC-10 includes a DOT 4BA350 cylinder pressurized with dry nitrogen to 350 psig @ 70° F (24.1 bar @ 21 °C), a brass valve with pressure gauge, and a wall mounting bracket. A Model MCH3, NMCH3, or ECH3 control head must be purchased separately and connected to the PAC-10 to open the valve. See **Figure 2-8**.

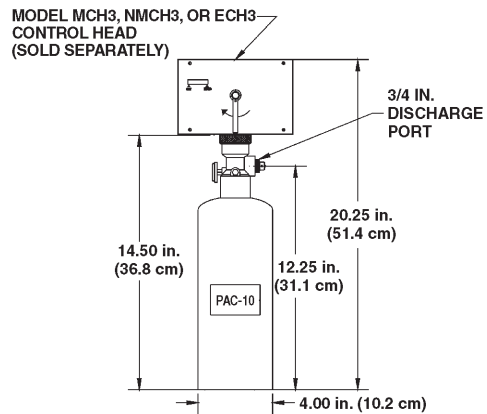

Figure 2-8. Model PAC-10 Pneumatic Actuating Cylinder.

002847PC

DETECTION EQUIPMENT

Model FLK-1 (P/N 550131)

The Model FLK-1 fusible link kit includes a 10 in. (25.4 cm) steel bracket, two (2) 1/2 in. EMT connectors, two (2) cable crimps, and two (2) “S” hooks. Fusible links must be ordered separately. See **Figure 2-9a**.

Model FLK-1A (P/N 550132)

The Model FLK-1A fusible link kit includes an 8 in. (20.3 cm) steel bracket, two (2) 1/2 in. EMT connectors, two (2) cable crimps, and two (2) “S” hooks. Fusible links must be ordered separately.

Model FLH-1 (P/N 550876)

The Model FLH-1 fusible link hanger is an accessory designed to simplify the installation of fusible links in the fusible link line. It can be used with the Model FLK-1 fusible link kit (kits must be ordered separately). The Fusible Link Hanger makes it possible to install fusible links without cutting and crimping loops in the fusible link line for each link. They are available in packages of 25 (FLH-25) only. See **Figure 2-9b**.

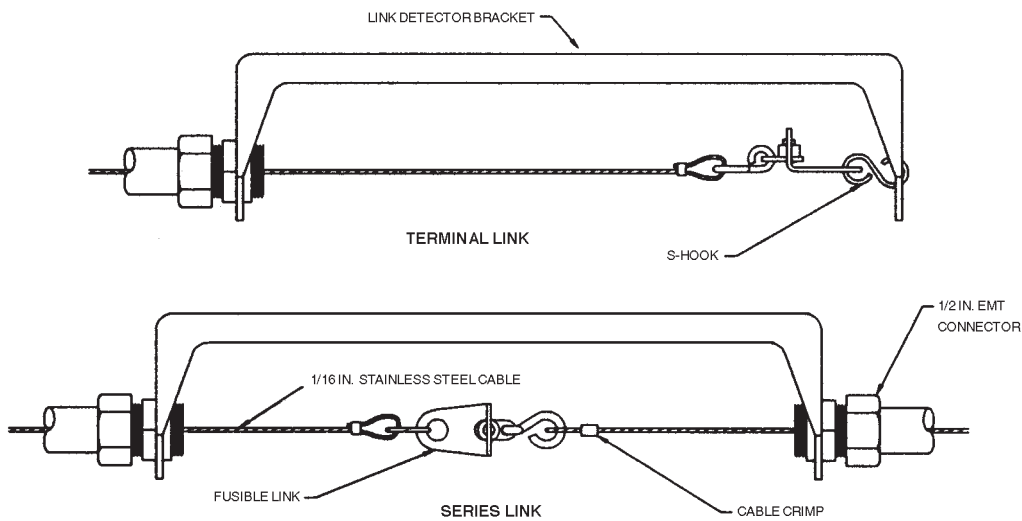

Figure 2-9a. Model FLK-1 Fusible Link.

002849PC

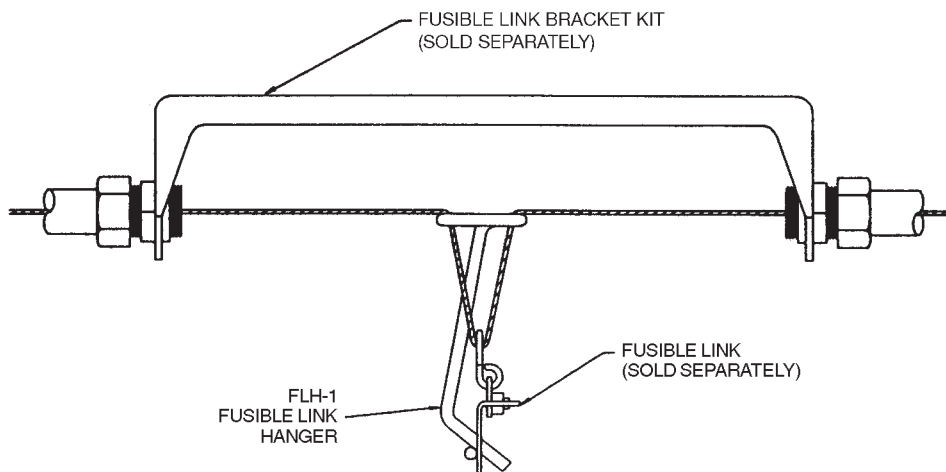

Figure 2-9b. Model FLH-1 Fusible Link Hanger.

002850PC

Fusible Links

The fusible link is designed to separate at a specific temperature, releasing tension from the fusible link line, causing system actuation. See **Figure 2-10**.

► **Note:** When possible, temperature readings should be taken at each detector location to determine optimum fusible link temperature ratings. Temperature can be recorded using either a maximum registering thermometer, Part No. 15240, temperature tape (by others), or any other accurate thermometer that will record the maximum temperature experienced at the detector location.

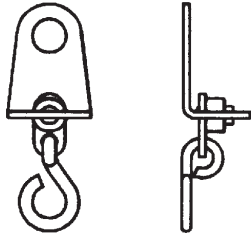

Figure 2-10. ML Style Fusible Link.

002851PC

After determining the maximum ambient temperature at the fusible link location, select the correct fusible link according to the temperature condition chart below:

Fusible Link Model No.	To Be Used Where Temperature Does Not Exceed	Part Number
FL-165	100° F. (38° C.)	550368
FL-212	150° F. (66° C.)	550365
FL-280	225° F. (107° C.)	550366
FL-360	290° F. (143° C.)	550009
FL-450	360° F. (182° C.)	550367
FL-500	400° F. (204° C.)	56816

Thermal Detectors

► Rate-compensating thermal detectors are normally open, mechanical contact closure switches designed to operate at a factory preset temperature. They are available in four preset temperatures which meet NFPA standards and are UL Listed and FM Approved. After determining the maximum ambient temperature at the thermal detector location, select the correct thermal detector according to the temperature condition chart below:

Thermal Detector Model No.	Maximum Ambient Temperature	Part Number
TD-225	155° F. (68° C.)	13976
TD-325	255° F. (124° C.)	13975
TD-450	380° F. (193° C.)	13974
TD-600	530° F. (277° C.)	13971

► **Note:** A transient rush of warm air up to 40 °F (4 °C) per minute may expand the shell, but not enough to trigger the unit. Temperature increases over 40 °F (4 °C) per minute however, may initiate an alarm condition.

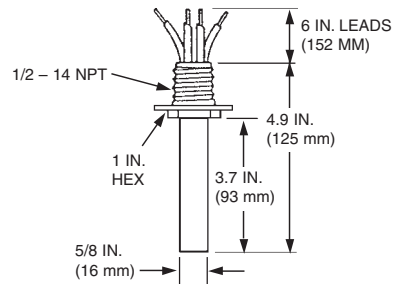

Figure 2-11. Thermal Detector.

Flexible Conduit

Flexible Conduit can be used with the Mechanical Pull Station Assembly (Part No. 551074) and Mechanical Gas Valves. Flexible Conduit eliminates the need for rigid EMT conduit in the mechanical pull station and gas valve lines, significantly reducing the overall installation time.

Part No.	Description
434525	Flexible Conduit – 500 ft (152 m)
435959	Flexible Conduit – 500 ft (152 m) and Wire Rope – 500 ft (152 m)
435979	Flexible Conduit Strain Relief (50-Pack)
434347	Flexible Conduit Insert (50-Pack)
436063	Conduit Offset (6-Pack)
436150	P-Clip (50-Pack)
79827	Compression Union, 1/2 in.
► 55813	1/2 in. Compression Connector

MODEL RPS-M - REMOTE MECHANICAL PULL STATION (P/N 551074)

Remote manual control for the Model MCH3, NMCH3, or ECH3 control head is provided by the Model RPS-M remote mechanical pull station. It is connected to the system control head by stainless steel cable. This cable is enclosed in 1/2 in. EMT conduit with corner pulleys or flexible conduit with bends and/or corner pulleys at each change in direction. The remote mechanical pull station shall be located at the point of egress. See Figure 2-12.

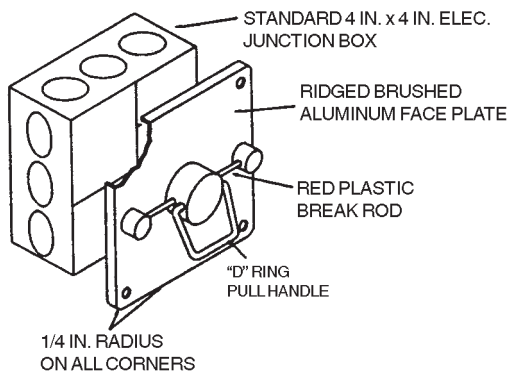
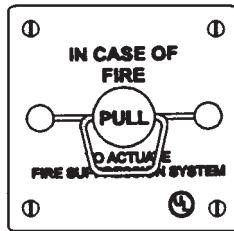

Figure 2-12. Model RPS-M Mechanical Pull Station.
 002852PC

“QUIK-SEAL” ADAPTOR

The “Quik-Seal” adaptor is a listed mechanical bulkhead fitting that produces a liquid-tight seal around both distribution piping and detection conduit which runs through restaurant hoods and ducts. The “Quik-Seal” adaptor accepts threaded pipe or conduit. The adaptor is available for 3/8 in. and 1/2 in. pipe or conduit sizes. When using with EMT conduit, a conduit connector must be installed in each end of the adaptor. The “Quik-Seal” Adaptor Shipping Assembly can be ordered in single or package of 24.

Size	Shipping Assembly Part No.	Qty.	Hole Size Required
3/8 in.	550857	1	1 1/8 in.
1/2 in.	550859	1	1 1/8 in.
3/8 in.	550858	24	1 1/8 in.
1/2 in.	550860	24	1 1/8 in.

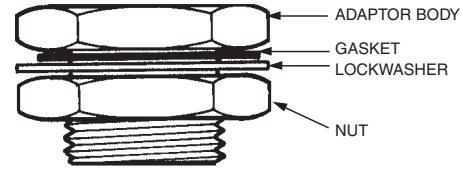

Figure 2-13. Quik-Seal Adaptor.

“COMPRESSION-SEAL” ADAPTOR

This adaptor is a mechanical bulkhead fitting that produces a liquid-tight seal around pipe and conduit when installing distribution piping and detection conduit through restaurant hoods and ducts. The “Compression-Seal” Adaptor is a straight-through design requiring no cutting or threading of conduit or pipe. The adaptor is available for EMT conduit size of 1/2 in. (Part No. 79152). See Figure 2-13. “Compression-Seal” Adaptor Shipping Assembly must be ordered as stated below:

Size	Shipping Assembly Part No.	Qty.	Hole Size Required
1/2 in. EMT Conduit	79153	24	1 1/8 in.

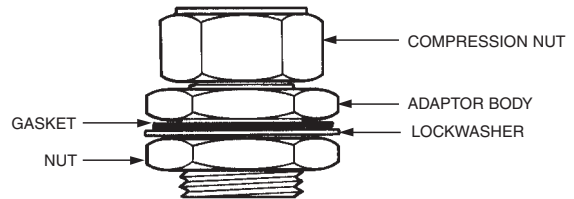

Figure 2-13a. Compression-Seal Adaptor.

“HOOD SEAL” ADAPTOR ASSEMBLY

This adaptor is a mechanical bulkhead fitting that produces a liquid-tight seal around 1/2 in. EMT conduit when installing the detection line through restaurant hoods and duct. The adaptor accepts a high temperature pulley elbow and, when used, correctly positions the elbow or conduit in line with the conduit adaptor hole in the detector bracket. The “Hood Seal” eliminates the need for multiple elbows when penetrating the top of a hood when installing the detection line. “Hood Seal” Adaptors are available in quantities of 6 as Shipping Assembly P/N 423253.

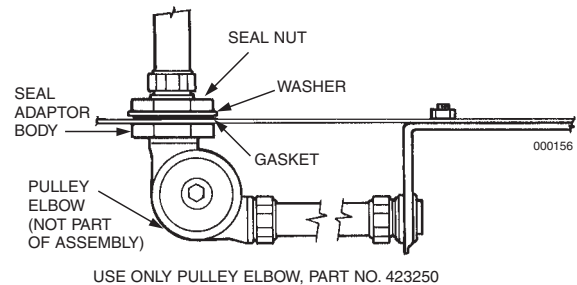

Figure 2-13b. Hood Seal Adaptor Assembly.

GAS SHUT-OFF VALVES

► **Note:** Gas valves are approved for indoor use only.

GV Mechanical Gas Shut-off Valve

A gas shut-off valve is required on all systems used to protect a gas fueled cooking appliance to stop gas flow in the event of system actuation. A mechanical gas valve can be used with the Model MCH3 control head. It is connected to the system control head by stainless steel cable. This cable is enclosed in 1/2 in. EMT conduit with a corner pulley at each change in direction. The valves are rated for natural and LP gas (see

► **Figure 2-14**). Mechanical gas valves are available in the following sizes:

► **Note:** Maximum operating pressure for all sizes of GV Mechanical Gas Valve is 5 psi (0.4 bar).

Model No.	Valve Size	Dim. "A"	Part Number
GV-75	3/4 in.	3/8 in. (1.0 cm)	550593
GV-100	1 in.	3/8 in. (1.0 cm)	550594
GV-125	1-1/4 in.	15/32 in. (1.2 cm)	550595
GV-150	1-1/2 in.	15/32 in. (1.2 cm)	550596
GV-200	2 in.	15/32 in. (1.2 cm)	551049
GV-250	2-1/2 in.	29/32 in. (2.3 cm)	550185
GV-300	3 in.	29/32 in. (2.3 cm)	550186

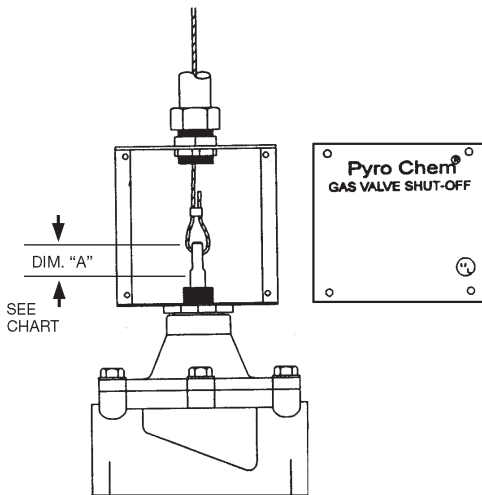

► **Figure 2-14. GV-Series Mechanical Gas Valve.**

002853PC

EGVSO Electric Gas Shut-off Valve

A gas shut-off valve is required on all systems used to protect a gas fueled cooking appliance to stop gas flow in the event of system actuation. A UL Listed electric gas valve can be used with either the Model MCH3 or ECH3 control head. The valves are rated for natural and LP gas. Valves are available in ► 120 VAC (see **Figure 2-14a**). Electric gas valves are available in the following sizes:

Model No.	Valve Size	Maximum Operating Pressure	Part Number
► EGVSO-75	3/4 in.	50 psi (3.5 bar)	13707
EGVSO-100	1 in.	25 psi (1.7 bar)	13708
EGVSO-125	1-1/4 in.	25 psi (1.7 bar)	550360
EGVSO-150	1-1/2 in.	25 psi (1.7 bar)	13709
EGVSO-200	2 in.	25 psi (1.7 bar)	13710
EGVSO-250	2-1/2 in.	5 psi (0.3 bar)	550363
► EGVSO-300	3 in.	5 psi (0.3 bar)	17643

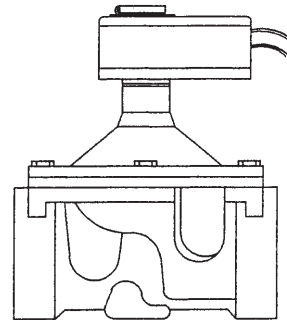

► **Figure 2-14a. Electric Gas Shut-off Valve.**

006844PC

Note: A UL Listed manual reset relay is required when using an electric gas valve. The PYRO-CHEM KITCHEN KNIGHT II ► Model SM-120 solenoid monitor must be used for this purpose.

CORNER PULLEYS

Model SBP-1 (P/N 415670)

A corner pulley is used whenever a change in stainless steel cable direction is required. The Model SBP-1 corner pulley is equipped with a set screw fitting for connection to 1/2 in. EMT conduit. See **Figure 2-15**.

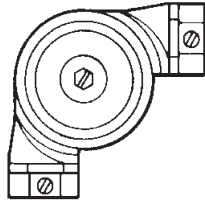

▶ **Figure 2-15. Model SBP-1 Corner Pulley.**

000160

Model CBP-1 (P/N 423250)

A corner pulley is used whenever a change in stainless cable direction is required. The Model CBP-1 is a grease-tight corner pulley designed for areas likely to experience excessive deposit build-up. It is equipped with a compression fitting for connection to 1/2 in. EMT conduit. See **Figure 2-16a**.

Note: The Model CBP-1 is not a liquid tight seal for penetration of hoods and/or ducts.

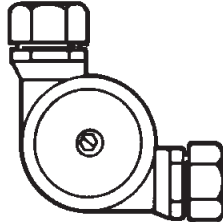

▶ **Figure 2-16a. Model CBP-1 Corner Pulley.**

000161

Model WBP-1 (P/N 550982)

A corner pulley is used whenever a change in stainless cable direction is required. The Model WBP-1 is a weather-proof corner pulley designed for areas likely to be exposed to moisture. It is equipped with female pipe threads for connection to 1/2 in. rigid conduit. See **Figure 2-16b**.

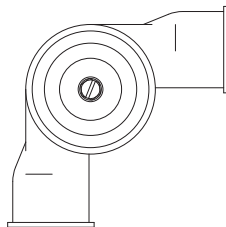

▶ **Figure 2-16b. Model WBP-1 Corner Pulley.**

006194PC

TEE PULLEY (P/N 427929)

The Tee Pulley is used to change the direction of two wire ropes by 90°. It must be used in areas where the temperatures are within the range of 32 °F to 130 °F (0 °C to 54 °C). Pulley tees can be used in mechanical gas valve actuation lines and remote manual pull station lines. Pulley tees cannot be used within a detection line. See **Figure 2-17**.

CAUTION

The Tee Pulley must never be used to connect multiple fusible link lines to a single control head.

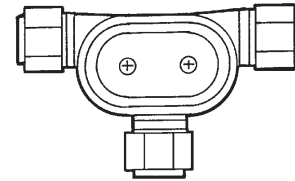

▶ **Figure 2-17. Model TP-1 Tee Pulley.**

000447

WIRE ROPE

The 1/16 in. diameter stainless steel wire rope must be used with actuators, detectors and gas valve components requiring a wire rope connection. The stainless steel wire rope is supplied in 50 ft (15.2 m) lengths with P/N 15821, and 500 ft (152 m) lengths with P/N 79653. Refer to the Components List for part numbers on crimps, stop sleeves, and S-hooks.

ELECTRICAL SWITCHES

The electrical switches are intended for use with electric gas valves, alarms, contactors, lights, contractor supplied electric power shut-off devices and other electrical devices that are designed to shut-off or turn on when the system is actuated.

NOTE

No electrical connections shall be made inside the control head. All electrical wiring shall exit the control head through the knock-out on the side of the box. All electrical connections must be made in an approved electrical box.

Switches are available in kits: One Switch Kit, Part No. 551154; Two Switch Kit, Part No. 551155; Three Switch Kit, Part No. 551156, and Four Switch Kit, Part No. 551157. Mounting hardware and 12 in. wire assemblies are provided with each kit. Each switch has a set of single-pole, double-throw contacts rated:

UL/cUL/CSA Rating
 250 VAC, 21A Resistive
 250 VAC, 2 HP
 125 VAC, 1 HP

ENEC Rating
 IE4T105 μ Approved
 250V, 21A Resistive
 8A Motor Load

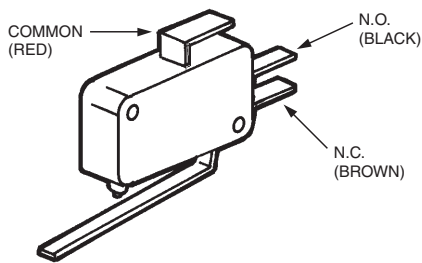

► **Figure 2-17a. Model MS-SPDT Snap-Action Switch.**
 001612

The Alarm Initiating Switch Kit, P/N 550077, can be field mounted within the control head. This switch must be used to close a supervised circuit to the building main fire alarm panel when the control head actuates. This action will signal the fire alarm panel that there was a system actuation in the kitchen area. The switch kit contains all necessary mounting components along with a mounting instruction sheet. The switch is rated 50 mA, 28 VDC.

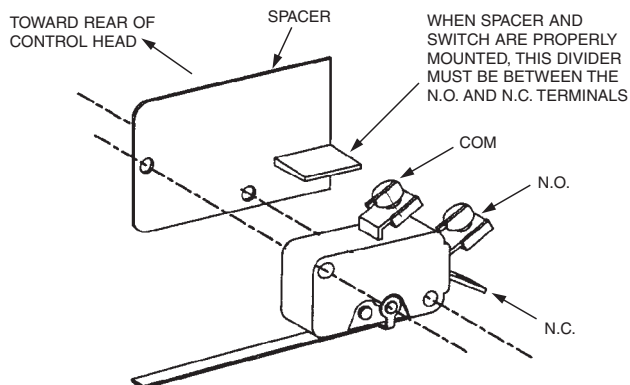

Figure 2-17b. Alarm Initiating Switch.
 004890

See NFPA 72, “National Fire Alarm Code,” Initiating Devices section, for the correct method of wiring connection to the fire alarm panel.

► MODEL SM-120 SOLENOID MONITOR

► The Model SM-120 solenoid monitor is (P/N 550302) used in conjunction with the Model ECH3-120 control head to supervise the actuation and detection circuits. In the event of a problem in the circuit, a light on the monitor goes out. Two sets of NO/NC dry contacts are provided. The unit mounts directly to a three gang wall outlet box. The Model SM-120 acts as a reset relay when used with an electric gas valve. Electric gas valve wiring instructions are provided in the installation section of this manual. See **Figure 2-18**.

► **Note:** When utilizing electric detection, it is recommended that the Model ECH3-24 electric control head be used with either the AUTOPULSE 542R Control Panel (P/N 433607) or the AUTOPULSE Z-10 Control Panel (P/N 430525). If the ECH3-120 control head is to be utilized, it must be used with Solenoid Monitor, Model SM-120 (P/N 550303), along with a UL Listed 1A, 120VAC secondary power supply (by others), in accordance with NFPA 17A, NFPA 96, and the local authority having jurisdiction. When the Solenoid Monitor, Model SM-120 (P/N 550303), is used as a reset relay with an electric gas valve, a UL Listed 1A, 120VAC secondary power supply is not required.

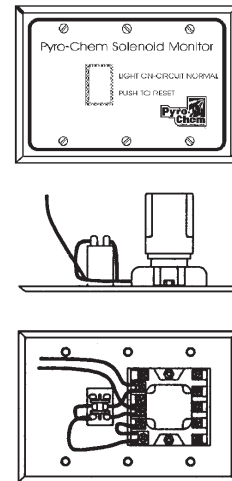

► **Figure 2-18. Model SM-120 Solenoid Monitor.**
 002860PC

PIPE AND FITTINGS

Pipe and fittings must be furnished by the installer. Schedule 40 stainless steel, chrome plated, or black pipe and fittings must be used. Galvanized pipe and fittings are not to be used.

AGENT DISTRIBUTION HOSE AND RESTRAINING CABLE KIT

The Agent Distribution Hose and Restraining Cable Kit, Part No. 435982, consists of a 5 ft (1.5 m) long Agent Distribution Hose, a 3 ft (0.9 m) long Restraining Cable, and a Restraining Cable Hardware Package. The Agent Distribution Hose can be utilized with castered appliances found in commercial kitchens. The hose allows for movement of the appliance for cleaning without having to disconnect any fire suppression system discharge piping.

STAINLESS STEEL ACTUATION HOSE

The Stainless Steel Actuation Hose is used to connect the actuation line compression tees and can also be connected end to end. The hose has the same thread, 7/16-20, as the fittings.

See Figure 2-19.

Hose Part No.	Length
417582	8 in. (20 cm)
31809	16 in. (41 cm)
32336	24 in. (61 cm)
430815	42 in. (107 cm)

Fitting Part No.	Description
31810	Male Elbow (7/16-20 x 1/4 in. NPT)
31811	Male Tee (7/16-20 x 7/16-20 x 1/4 in. NPT)
32338	Male Straight Connector (7/16-20 x 1/4 in. NPT)



Figure 2-19. Stainless Steel Actuation Hose.
 000433

NOZZLES

Nozzles have been developed for appliance, plenum, and duct applications. All nozzles have a specific flow point value and are supplied with metal blow-off caps to prevent clogging. Each nozzle is stamped with the model number. See Figure 2-20. Application limitations are provided in the design section of this manual.

Part No.	Description	Flow No.
551029	1H Nozzles, pack of ten (10)	1
551026	1L Nozzles, pack of ten (10)	1
551028	2H Nozzles, pack of ten (10)	2
551027	2L Nozzles, pack of ten (10)	2
551038	2D Nozzles, pack of ten (10)	2

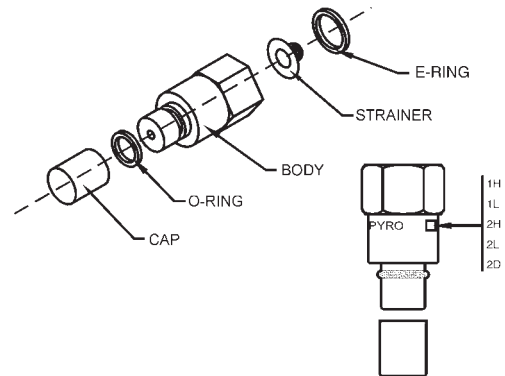

Figure 2-20. Nozzles.
 006171PC

RUBBER BLOW-OFF CAPS

The Rubber Blow-Off Cap helps keep the orifice of the nozzle free of grease or other substances that could interfere with agent distribution. A retaining strap attaches the blow-off cap to the nozzle. Rubber Blow-Off Caps must be ordered as a Shipping Assembly, Part No. 550016, which contains 12 blow-off caps.

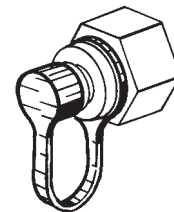

Figure 2-21.
 000009

SWIVEL ADAPTOR (P/N 418569)

The Swivel adaptor consists of a swivel nut, swivel body, and swivel ball. All are chrome-plated. The swivel adaptor allows the nozzle to be rotated approximately 30° in all directions. Swivel Adaptors can be ordered as a single Swivel Adaptor or Swivel Adaptor Shipping Assembly, Part No. 423572, which contains 25 swivel adaptors. See Figure 2-22.

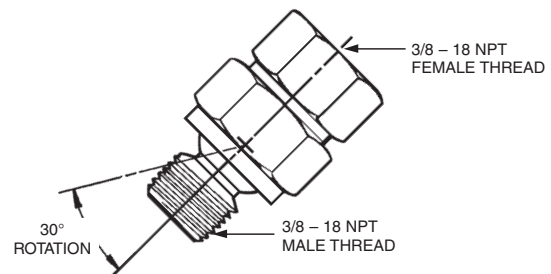
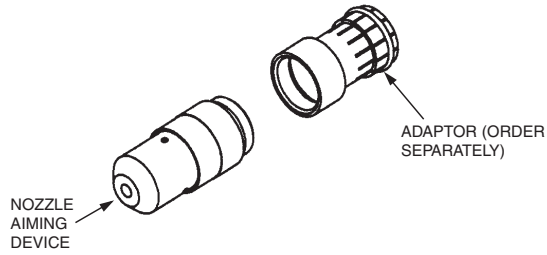

Figure 2-22. Swivel Adaptor.
 000003

NOZZLE AIMING DEVICE

The Nozzle Aiming Device, Part No. 551265, is required to properly aim each nozzle to the correct aiming point. The device clamps to the nozzle and emits a small laser light that reflects on the surface that it is aiming at. The nozzle can then be rotated to point at a predetermined aiming point and then tightened to hold that angle. The aiming device requires an adaptor, Part No. 550926, to attach it to the nozzle. The adaptor

▶ must be ordered separately. See **Figure 2-23**.



▶ **Figure 2-23. Nozzle Aiming Device.**

006520

COMPONENTS LIST

<u>MODEL NO.</u>	<u>DESCRIPTION</u>	<u>PART NO.</u>	<u>MODEL NO.</u>	<u>DESCRIPTION</u>	<u>PART NO.</u>
PCL-160	1.6 GALLON CYLINDER ASSEMBLY	553163	▶ EGVSO-75	ELECTRIC GAS SHUT-OFF VALVE 3/4 IN.	13707
PCL-300	3.0 GALLON CYLINDER ASSEMBLY	551194	▶ EGVSO-100	ELECTRIC GAS SHUT-OFF VALVE 1 IN.	13708
PCL-460	4.6 GALLON CYLINDER ASSEMBLY	551193	EGVSO-125	ELECTRIC GAS SHUT-OFF VALVE 1-1/4 IN.	550360
PCL-600	6.0 GALLON CYLINDER ASSEMBLY	551196	▶ EGVSO-150	ELECTRIC GAS SHUT-OFF VALVE 1-1/2 IN.	13709
PAC-10	PNEUMATIC ACTUATING CYLINDER	550104	▶ EGVSO-200	ELECTRIC GAS SHUT-OFF VALVE 2 IN.	13710
PCL-300	CANADIAN – 3.0 GALLON CYLINDER ASSEMBLY	551195	EGVSO-250	ELECTRIC GAS SHUT-OFF VALVE 2-1/2 IN.	550363
PCL-460	CANADIAN – 4.6 GALLON CYLINDER ASSEMBLY	551192	▶ EGVSO-300	ELECTRIC GAS SHUT-OFF VALVE 3 IN.	17643
PCL-600	CANADIAN – 6.0 GALLON CYLINDER ASSEMBLY	551197	GV-75	MECHANICAL GAS SHUT-OFF VALVE 3/4 IN.	550593
PAC-10	CANADIAN – PNEUMATIC ACTUATING CYLINDER	551125	GV-100	MECHANICAL GAS SHUT-OFF VALVE 1 IN.	550594
MB-1	MOUNTING BRACKET (FOR PCL-600)	550053	GV-125	MECHANICAL GAS SHUT-OFF VALVE 1-1/4 IN.	550595
MB-15	MOUNTING BRACKET (FOR PCL-160/300/460)	550054	GV-150	MECHANICAL GAS SHUT-OFF VALVE 1-1/2 IN.	550596
▶ MB-P2	MOUNTING BRACKET (FOR MCH3 ECH3-24/120)	550853	GV-200	MECHANICAL GAS SHUT-OFF VALVE 2 IN.	551049
MCH3	MECHANICAL CONTROL HEAD	551200	GV-250	MECHANICAL GAS SHUT-OFF VALVE 2-1/2 IN.	550185
NMCH3	MECHANICAL CONTROL HEAD (NO HANDLE)	551203	GV-300	MECHANICAL GAS SHUT-OFF VALVE 3 IN.	550186
EN-MCU3	ENCLOSURE (FOR PRIMARY CYLINDER)	551208	▶ MS-SPDT	ELECTRICAL SWITCH – SINGLE POLE DOUBLE THROW	551154
EN-S	ENCLOSURE (FOR SECONDARY CYLINDER)	550966	▶ MS-DPDT	ELECTRICAL SWITCH – DOUBLE POLE DOUBLE THROW	551155
ECH3-24	24VDC ELECTRICAL CONTROL HEAD	551201	▶ MS-3PDT	ELECTRICAL SWITCH – 3 POLE DOUBLE THROW	551156
ECH3-120	120VAC ELECTRICAL CONTROL HEAD	551202	▶ MS-4PDT	ELECTRICAL SWITCH – 4 POLE DOUBLE THROW	551157
– – –	8 IN. S.S. ACTUATION HOSE	417582	– – –	ALARM INITIATING SWITCH	550077
– – –	16 IN. S.S. ACTUATION HOSE	31809	CO2-6	6 x CO2 CARTRIDGE (16 GM)	551059
– – –	24 IN. S.S. ACTUATION HOSE	32336	– – –	O-RING, ACTUATOR ASSEMBLY	55531
– – –	42 IN. S.S. ACTUATION HOSE	430815	CBP-1	COMPRESSION BEARING CORNER PULLEY	423250
– – –	MALE ELBOW	31810	SBP- 1	SCREW BEARING CORNER PULLEY	415670
– – –	MALE TEE	31811	WBP-1	WEATHER PROOF BEARING CORNER PULLEY	550982
– – –	MALE STRAIGHT CONNECTOR	32338	TP-1	TEE PULLEY	550166
1H	WET NOZZLE (PACK OF 10)	551029	– – –	WET VALVE CAP	550831
1L	WET NOZZLE (PACK OF 10)	551026	– – –	CONICAL SPRING (WET VALVE)	550705
2H	WET NOZZLE (PACK OF 10)	551028	– – –	PRESSURE GAUGE (WET VALVE)	551236
2L	WET NOZZLE (PACK OF 10)	551027	– – –	PRESSURE REGULATOR ASSEMBLY	550985
2D	WET NOZZLE (PACK OF 10)	551038	– – –	WET VALVE REBUILDING KIT	550698
– – –	SWIVEL ADAPTOR (PACK OF 25)	423572	– – –	PRESSURE REGULATOR REBUILD KIT	551061
– – –	RUBBER BLOW-OFF CAPS (PACK OF 12)	550016	VT-1	VALVE TOOL (WET VALVE)	550788
RPS-M	REMOTE MECHANICAL PULL STATION	551074	– – –	NECK O-RING (WET VALVE)	550716
FLK-1	10 IN. FUSIBLE LINK BRACKET KIT	550131	– – –	PISTON (WET VALVE)	550707
FLK-1A	8 IN. FUSIBLE LINK BRACKET KIT	550132	– – –	PISTON O-RING (WET VALVE)	550715
FLH-25	25 x FUSIBLE LINK HANGER	550876	– – –	VALVE CAP O-RING (WET VALVE)	550714
FL-165	FUSIBLE LINK 165°F	550368	RL-160	1.6 GALLON RECHARGE	553176
FL-212	FUSIBLE LINK 212°F	550365	RL-300	3.0 GALLON RECHARGE	551188
FL-280	FUSIBLE LINK 280°F	550366	PCL-300T	TEST TANK	551024
FL-360	FUSIBLE LINK 360°F	550009	PCL-460T	TEST TANK	550902
FL-450	FUSIBLE LINK 450°F	550367	PCL-600T	TEST TANK	550901
FL-500	FUSIBLE LINK 500°F	56816	– – –	RUBBER BLOW-OFF CAP	550016
▶ SM-120	120VAC SOLENOID MONITOR	550302			
TD-225	THERMAL DETECTOR 225°F	13976			
TD-325	THERMAL DETECTOR 325°F	13975			
TD-450	THERMAL DETECTOR 450°F	13974			
TD-600	THERMAL DETECTOR 600°F	13971			

COMPONENTS LIST (Continued)

<u>MODEL NO.</u>	<u>DESCRIPTION</u>	<u>PART NO.</u>
-- --	10 x WET NOZZLE CAP	551528
-- --	10 x WET NOZZLE STRAINER	551529
-- --	10 x WET NOZZLE O-RING	551530
-- --	VALVE STEM O-RING	550028
-- --	COMPLETE WET VALVE ASSEMBLY	551175
PCL-AK	RECHARGE ADAPTOR KIT	551240
-- --	MEASURING STICK	551039
-- --	STAINLESS STEEL WIRE ROPE, 50 FT	15821
-- --	STAINLESS STEEL WIRE ROPE, 500 FT	79653
WC-100	OVAL SLEEVE CRIMPS (100 PER PACKAGE)	550122
-- --	STOP SLEEVES (PACK OF 10)	24919
▶ -- --	FLUSHING CONCENTRATE (32 OZ)	553568
-- --	FLEXIBLE CONDUIT – 500 FT (152 m)	434525
-- --	FLEXIBLE CONDUIT – 500 FT (152 m) AND WIRE ROPE – 500 FT (152 m)	435959
-- --	FLEXIBLE CONDUIT STRAIN RELIEF (50 PACK)	435979
-- --	FLEXIBLE CONDUIT INSERT (50 PACK)	434347
-- --	CONDUIT OFFSET (6-PACK)	436063
-- --	P-CLIP (50-PACK)	436150
-- --	COMPRESSION UNION, 1/2 IN.	79827
-- --	COMPRESSION CONNECTOR, 1/2 IN.	55813
-- --	HENNY PENNY NOZZLE KIT	553389
▶ CO2-6	6xCO2 CARTRIDGE	551059
-- --	COMPRESSION-SEAL ADAPTOR	79153
▶ -- --	AGENT DISTRIBUTION HOSE AND TETHER KIT	435982

CHAPTER III SYSTEM DESIGN

GENERAL

The KITCHEN KNIGHT II Restaurant Fire Suppression System may be used on a number of different types of restaurant cooking appliances and hood and duct configurations. The design information listed in this section deals with the limitations and parameters of this pre-engineered system. Those individuals responsible for the design of the KITCHEN KNIGHT II system must be trained and hold a current PYRO-CHEM certificate in a KITCHEN KNIGHT II training program.

The nozzle(s) must be installed on the centerline of the duct, with the tip located 0 to 6 in. (15.2 cm) into the opening, and aimed directly into the duct opening. See **Figure 3-1**.

In installations where a UL listed damper assembly is employed, the duct nozzle can be installed beyond the 6 in. (15.2 cm) maximum, to a point just beyond the damper assembly that will not interfere with the damper. Exceeding the maximum of 6 in. (15.2 cm) in this way will not void the UL listing of the system.

NOZZLE COVERAGE AND PLACEMENT

This section will provide guidelines for determining nozzle type, positioning, and quantity for duct, plenum, and appliance protection.

Duct Protection

It is not required that the fan be shut down or the exhaust duct be dampered for the system to operate properly.

All duct protection is UL listed without limitation of maximum duct length (unlimited length). This includes all varieties of ductworks both horizontal and vertical including ducts that run at angles to the horizontal and ducts with directional bends.

Duct protection requires that a nozzle be positioned to discharge into the duct. Two nozzles are available for duct protection.

The Model IL Nozzle, Part No. 551026, is a one (1) flow nozzle. A single IL nozzle is capable of protecting square or rectangular ducts with a maximum perimeter of 50 in. (127 cm) (maximum side of 16 3/4 in. (42.6 cm)), with the diagonal being a maximum of 18 3/4 in. (47.6 cm). It can also protect a round duct with a maximum diameter of 16 in. (40.6 cm).

The Model 2D duct nozzle, Part No. 551038, is a two (2) flow nozzle. A single 2D nozzle is capable of protecting square or rectangular ducts with a maximum perimeter of 100 in. (254 cm), with the diagonal being a maximum of 37 3/8 in. (94.9 cm). It can also protect a round duct with a maximum diameter of 31 7/8 in. (81 cm).

When two (2) 2D duct nozzles are used to protect a single duct, the cross sectional area of the duct must be divided into two equal symmetrical areas. The nozzle must then be installed on the centerline of the area it protects and aimed directly into the duct opening.

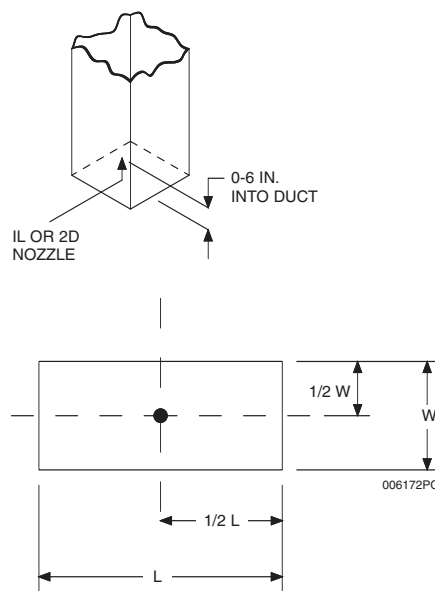

Figure 3-1.

Modularizing Ducts

DUCT SIZES GREATER THAN 100 IN. (254 cm) PERIMETER

- Ducts over 100 in. perimeter must be modularized using 2D nozzles (Part No. 551038)
- No round duct option available
- Follow the design chart to determine maximum module size for each 2D nozzle
- When determining number of nozzles required, it is sometimes an advantage to check the chart using the shortest side as Side "A" and then recheck it using the longest side as Side "A". This comparison may reveal a need for a lesser quantity of nozzles one way versus the other way.

When working with Chart 1, the quantity of nozzles determined must be equally divided within the duct area.

When working with Chart 2, one half of the quantity of nozzles determined must be equally positioned in the top half of the area of the duct and the remaining half of the nozzles must be positioned in the bottom half of the duct area.

Example: The duct to be protected has a Side "A" of 40 in. and a Side "B" of 60 in. Referring to the design chart, this duct requires 4 nozzles. One half of 4 = 2. Therefore, 2 nozzles must be equally positioned in each of the two duct areas. See ► **Figure 3-1a.**

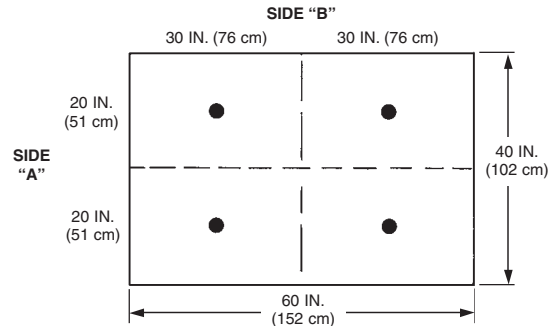

Figure 3-1a.

CHART NO. 1

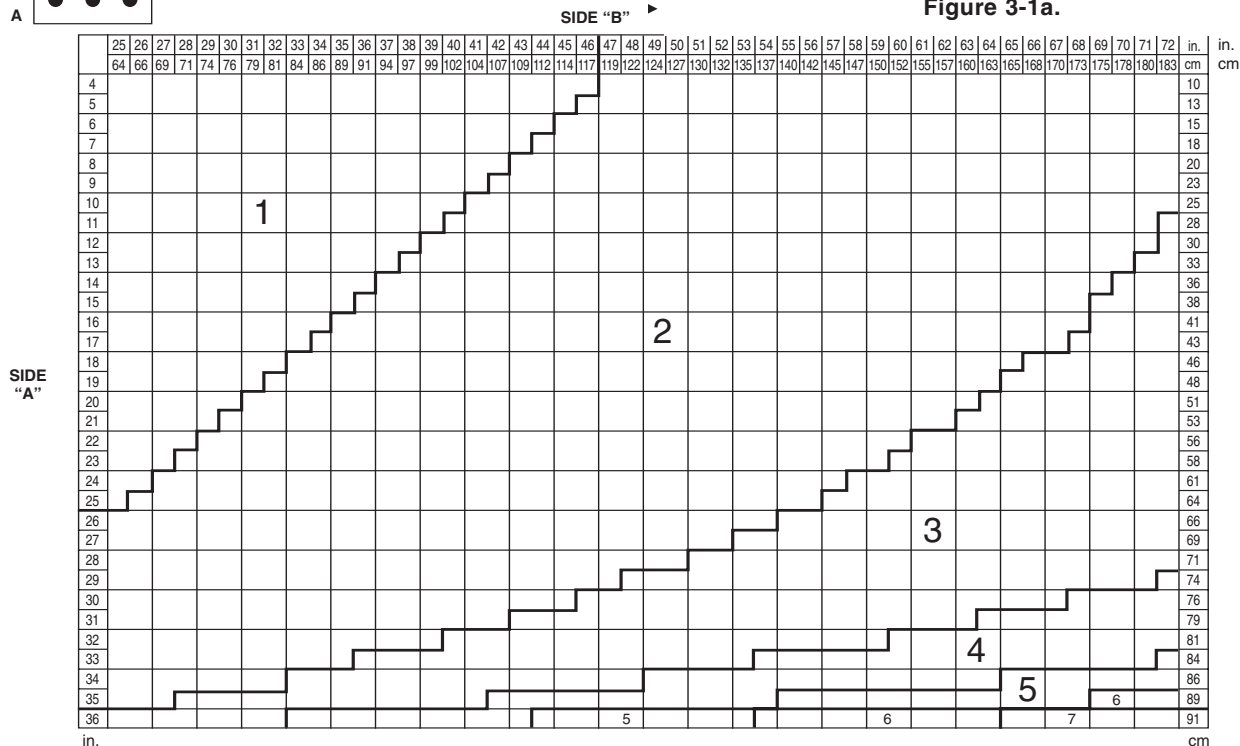
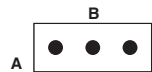
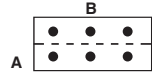
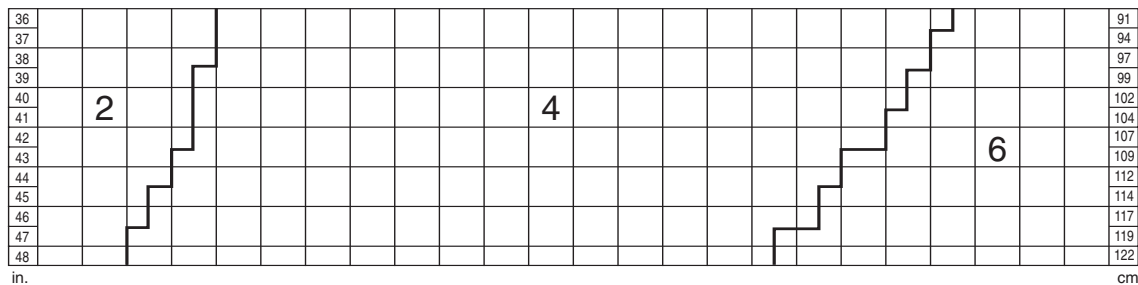

CHART NO. 2



NOTE: NOZZLE QUANTITIES LISTED IN CHART 2 MUST BE EQUALLY DIVIDED INTO EACH OF THE TWO DUCT MODULES.



Transition Ducts – The protection of non-standard ducts should be reviewed by the authority having jurisdiction. PYRO-CHEM KITCHEN KNIGHT II recommends that transition ducts be protected as follows:

a. Transition ducts – larger to smaller

In cases where the duct/plenum interface opening is larger than the final exhaust duct, measure the perimeter/diameter of the duct halfway between the largest and smallest section (or the average perimeter/diameter). The nozzle is to be located within 0-6 in. (15.2 cm) of the duct/plenum interface (not at the point where the measurement was taken), centered under the final exhaust duct opening. See **Figure 3-1b**.

Note: Nozzles to protect ducts with a transition that is more than 4 ft (1.2 m) in height, will be required to be positioned in the opening of the transition from the hood 2 to 8 in. (5.1 to 20.3 cm) into the opening using standard duct nozzle design parameters.

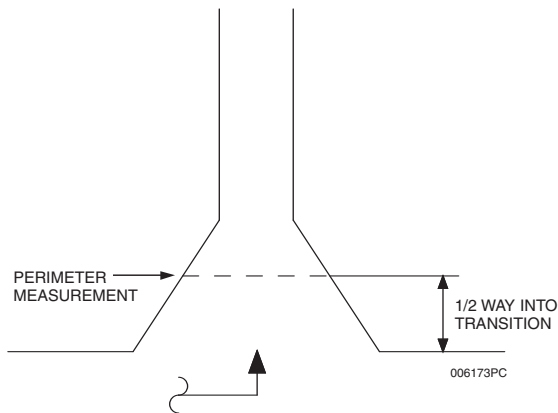

Figure 3-1b.

b. Transition ducts – smaller to larger

In cases where the duct/plenum interface opening is smaller than the final exhaust duct, measure the perimeter/diameter of the final exhaust duct. The nozzle(s) is to be located within 0-6 in. (15.2 cm) of the duct/plenum interface, centered in the opening. See **Figure 3-1c**.

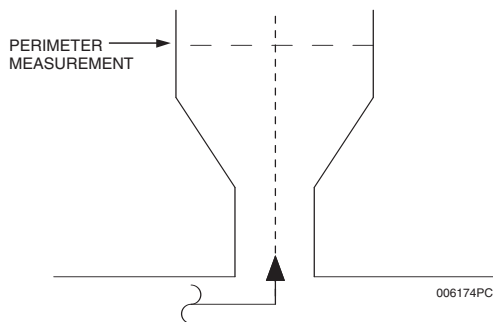

Figure 3-1c.

c. Multiple risers

In cases of multiple rises, each riser is protected as an individual duct. See **Figure 3-1d**.

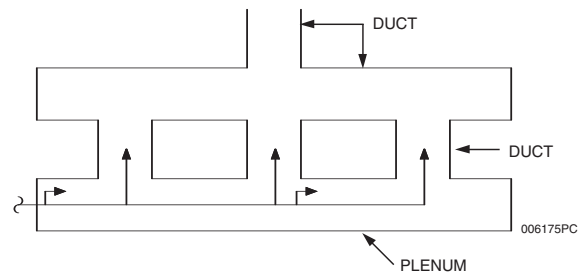

Figure 3-1d.

Electrostatic Precipitator – Ducts utilizing electrostatic precipitators must be protected above and below the unit. Standard duct nozzles are used in this application. See **Figure 3-1e**.

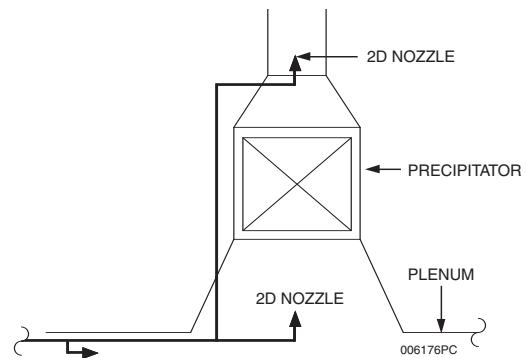

Figure 3-1e.

Plenum Protection

The Model 1H nozzle, Part No. 551029, is a one (1) flow nozzle used for plenum protection. A single 1H nozzle can protect a plenum (with single or V-bank filters) 10 ft (3.1 m) long by 4 ft (1.2 m) wide. Dividing the length into sections equal to or less than 10 ft (3.1 m) in length and positioning a nozzle at the start of each section can be done to protect longer plenums.

On V-bank plenums, the nozzle(s) must be located at the center of the V-bank width, 1/3 of the vertical height of the filters. On single filter bank plenums, the nozzle must be located 2 in. (5.1 cm) from the back edge of the filter, 1/3 down from the vertical height. For either application, the nozzle must be located within 6 in. (15.2 cm) of the end of the plenum (or module) and aimed directly down the length of the plenum. The nozzles may point in the opposite directions as long as the entire plenum area is protected, and the 10 ft (3.1 m) limitation is not exceeded. See **Figure 3-2**.

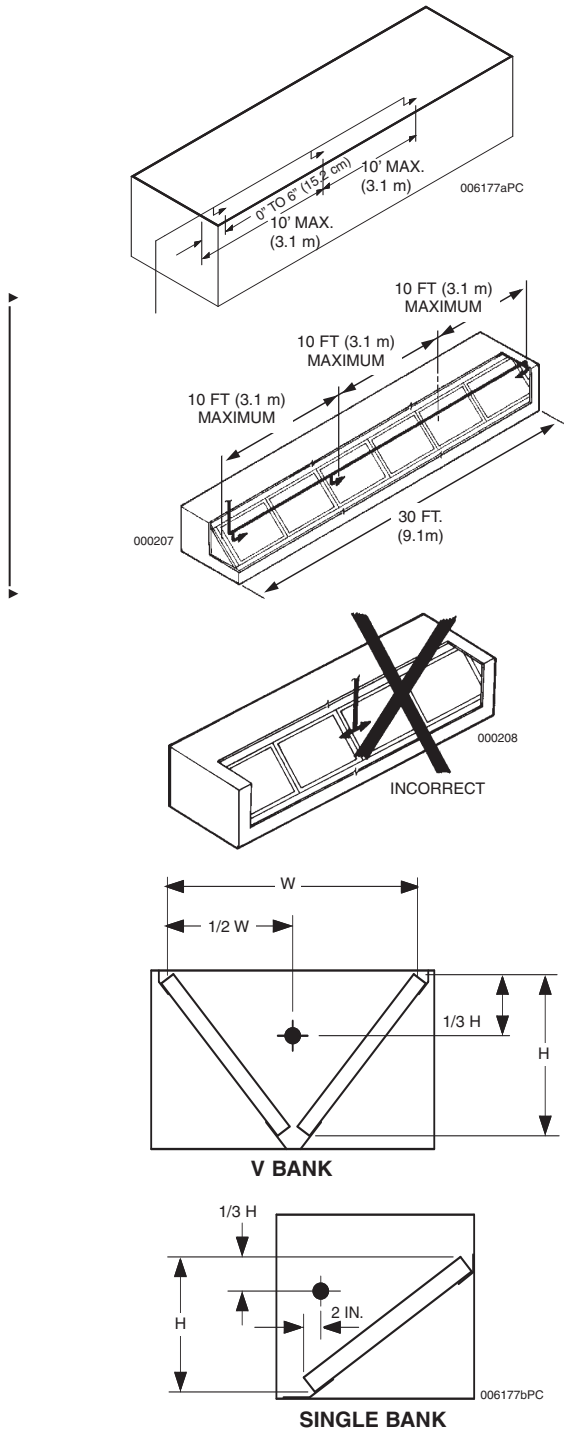

Figure 3-2.

Appliance Protection

Note: When protecting appliances which are larger than single nozzle coverage, multiple nozzles can be used.

Larger appliances can be divided into several modules, each equal to or smaller than single nozzle coverage. Exception: Fryers must not exceed a maximum of 864 sq in. (5574 sq cm).

For modularizing fryers, refer to "FRYER – MULTIPLE NOZZLE PROTECTION."

Design Chart

Appliance Type	Maximum Cooking Hazard Area per Nozzle
Fryer Without Drip Board	19 in. x 19 1/2 in. maximum (48 x 49.5 cm)
Fryer With Drip Board	18 in. x 27 3/4 in. (45.7 x 70.5 cm) maximum; 19 1/2 in. x 25 3/8 in. (49.5 x 64.5 cm) maximum
Small Range	Maximum area of 336 sq in. (2168 sq cm) with the longest side to be a maximum of 28 in. (71 cm)
Large Range	Maximum area of 784 sq in. (5058 sq cm) with the longest side to be a maximum of 28 in. (71 cm)
Small Wok	24 in. diameter x 6 in. deep (61 x 15.2 cm) maximum
Large Wok	30 in. diameter x 8 in. deep (76.2 x 20.3 cm) maximum
Small Griddle	Maximum area of 1080 sq in. (6968 sq cm) with the longest side to be a maximum of 36 in. (91.4 cm)
Large Griddle	Maximum area of 1440 sq in. (9290 sq cm) with the longest side to be a maximum of 48 in. (122 cm)
Gas Radiant Char-Broiler	Maximum area of 624 sq in. (4025.8 sq cm) with the longest side to be a maximum of 26 in. (66 cm)
Gas Radiant Char-Broiler	Maximum area of 864 sq in. (5574 sq cm) with the longest side to be a maximum of 36 in. (91.4 cm)
Lava Rock Char-Broiler	Maximum area of 624 sq in. (4025.8 sq cm) with the longest side to be a maximum of 26 in. (66 cm)
Natural Charcoal Broiler	Maximum area of 480 sq in. (3096.8 sq cm) with the longest side to be a maximum of 24 in. (61 cm)
Mesquite Char-Broiler	Maximum area of 480 sq in. (3096.8 sq cm) with the longest to be a maximum of 24 in. (61 cm)
Upright/Salamander Broiler	Maximum area of 1064 sq in. (6865 sq cm) with the longest side to be a maximum of 36 in. (91 cm)
Chain Broiler	Maximum area of 1026 sq in. (6619 sq cm) with the longest side to be a maximum of 38 in. (97 cm)

► **1. Fryers without Drip Board** (19 in. x 19 1/2 in. maximum) (48 x 49.5 cm)

Two nozzles are available for fryer protection: High proximity and low proximity.

The Model 2H nozzle, Part No. 551028, is used for high proximity fryer protection. This nozzle is a two (2) flow nozzle. The nozzle must be located **anywhere within the perimeter** of the hazard area, 24 in. to 48 in. (61 to 122 cm) above the cooking surface of the appliance and aimed at the center of the cooking area. See **Figure 3-3**.

► The Model 2L nozzle is used for low proximity fryer protection. This nozzle is a two (2) flow nozzle. The nozzle must be located **anywhere on the perimeter** of the hazard area, 13 in. to 24 in. (33 to 61 cm) above the cooking surface of the appliance and aimed at the center of the cooking area. See **Figure 3-3**.

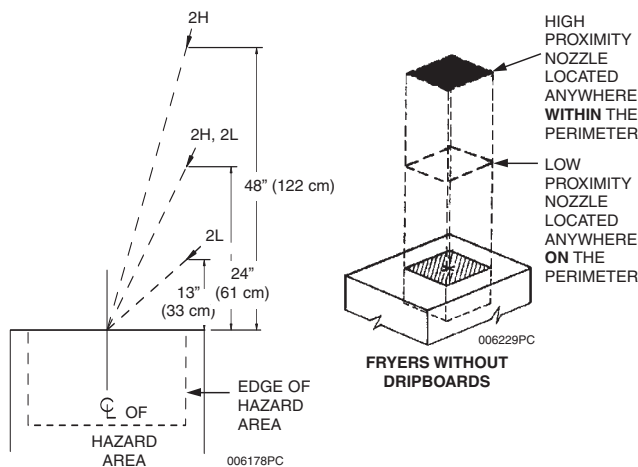

Figure 3-3.

► **1a. Fryers with Drip Board**

The maximum single nozzle protection dimensions depend on the dimensions of the fry pot only.

For fry pots with maximum dimensions of 18 in. (45.7 cm) on the longest side and 324 sq in. (2090 sq cm) max. area, use **overall** dimensions of 27 3/4 in. (70.5 cm) on the longest side and 500 sq in. (3226 sq. cm) max. area.

For fry pots with maximum dimensions exceeding 18 in. x 324 sq in. (2090 sq cm), but no greater than 19 1/2 in. (49.5 cm) on the longest side and 371 sq in. (2394 sq cm) max area, use **overall** dimensions of 25 3/8 in. (64.5 cm) on the longest side and 495 sq in. (3194 sq cm) area.

Two nozzles are available for fryer protection: High proximity and low proximity.

The Model 2H nozzle, Part No. 551028, is used for high proximity fryer protection. This nozzle is a two (2) flow nozzle. The nozzle must be located **anywhere within the perimeter** of the hazard area, 24 in. to 48 in. (61 to 122 cm) above the cooking surface of the appliance and aimed at the center of the cooking area. See **Figure 3-3b**.

The Model 2L nozzle is used for low proximity fryer protection. This nozzle is a two (2) flow nozzle. The nozzle must be located **anywhere on the perimeter** of the hazard

area, 13 in. to 24 in. (33 to 61 cm) above the cooking surface of the appliance and aimed at the center of the cooking area. See **Figure 3-3a**.

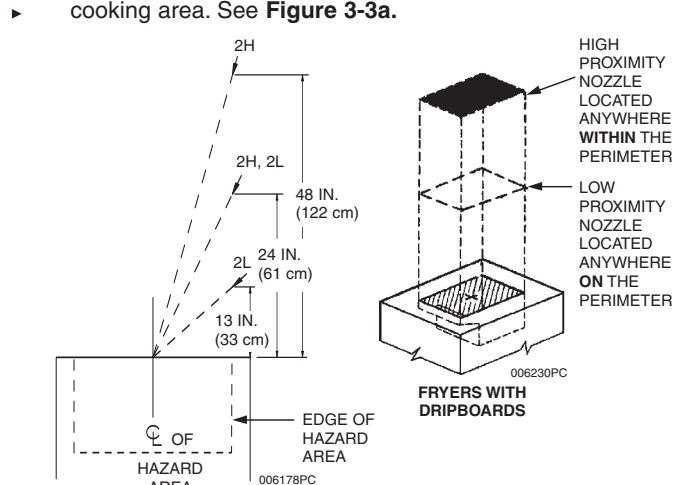

Figure 3-3a.

► **2. Small Range** (336 sq in. (2168 sq cm) maximum, 28 in. (71 cm) longest side maximum). Use this when nozzle is center located.

Two nozzles are available for small range protection: High proximity and low proximity.

The Model 1H nozzle, Part No. 551029, is used for high proximity small range protection. This nozzle is a one (1) flow nozzle. **When using high proximity protection, the range cannot be under a backshelf.** This nozzle must be located on the front/back centerline of the appliance, 40 in. to 50 in. (102 to 127 cm) above the cooking surface, and aimed directly down within the “Nozzle Location Area” depending on the size of the hazard area. See “Nozzle Placement” chart below. See **Figure 3-4**.

NOZZLE FLEXIBILITY PLACEMENT CHART (When using nozzle flexibility, the maximum width that can be protected is 12 in. (31 cm))

Length – L	Width – W	Front/Rear
in. (cm)	in. (cm)	in.* (cm)*
12 (31)	12 (31)	8 (20)
13 (33)	12 (31)	7 1/2 (19)
14 (36)	12 (31)	7 (18)
15 (38)	12 (31)	6 1/2 (17)
16 (41)	12 (31)	6 (15)
17 (43)	12 (31)	5 1/2 (14)
18 (45)	12 (31)	5 (13)
19 (48)	12 (31)	4 1/2 (11)
20 (51)	12 (31)	4 (10)
21 (53)	12 (31)	3 1/2 (9)
22 (56)	12 (31)	3 (8)
23 (58)	12 (31)	2 1/2 (6)
24 (61)	12 (31)	2 (5)
25 (64)	12 (31)	1 1/2 (4)
26 (66)	12 (31)	1 (3)
27 (69)	12 (31)	1/2 (1)
28 (71)	12 (31)	0 (0)

*Distance from centerline, either toward front or toward back, of hazard area, starting from the reference point.

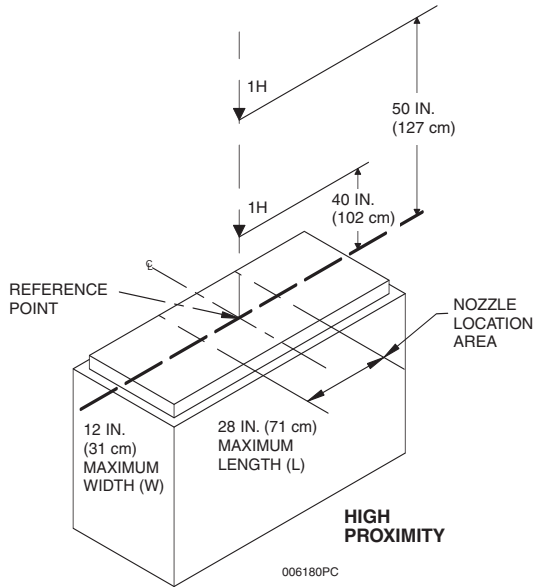

Figure 3-4.

- ▶ The Model 1L nozzle, Part No. 551026, is used for low proximity small range protection. This nozzle is a one (1) flow nozzle. **The range can be equipped either with or without a backshelf.** Either type requires the same nozzle requirements. The nozzle must be located 22 in. (56 cm) from either end of the hazard area centered from left to right. It must be 13 in. to 24 in. (33 to 61 cm) above cooking surface, and aimed at a point one half the distance of whatever the height dimension of the nozzle is. When determining nozzle and aim point locations, both measurements are to be taken from the **same** end of the hazard area. Example: The nozzle is mounted 20 in. (51 cm) above the cooking surface. The aim point from the edge of the hazard would then be 10 in. (25 cm) which is one half the nozzle mounting height dimension. See **Figure 3-4a.** **Note:** Nozzles must be placed at or below the shelf, within the nozzle height limitations.

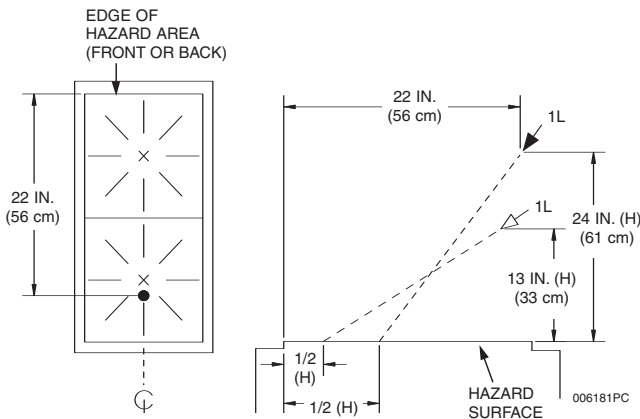
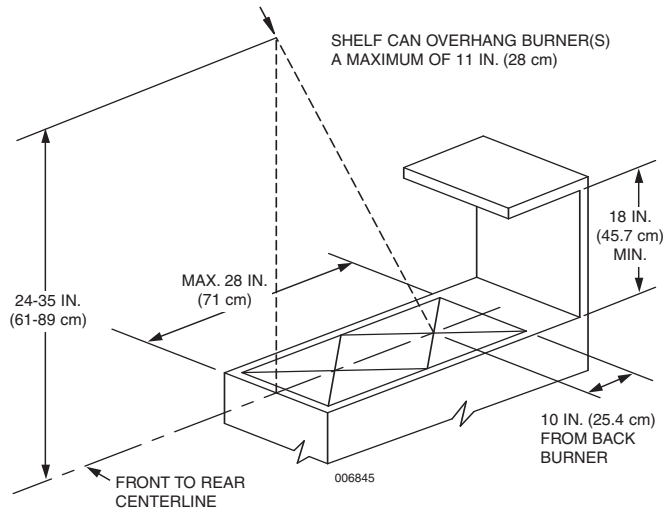

Figure 3-4a.

2a. High-Proximity Backshelf Protection – When using the 2L nozzle for range protection with high-proximity backshelf, the maximum length of burners being protected must not exceed 28 in. (71 cm) and the maximum area of the burners must not exceed 336 sq in. (2167 sq cm). The backshelf must be a minimum of 18 in. (45.7 cm) above the top of the range and may overhang the burner by a maximum of 11 in. (28 cm).

Note: Although most shelves exceed 11 in. (28 cm) in overall depth, make sure the shelf does not exceed 11 in. (28 cm) overhang of the burner.

Nozzle must be located on the front edge of the front burner and aimed at a point 10 in. (25 cm) forward from the back edge of the back burner on the front-to-rear centerline. Nozzle must be mounted 24 to 35 in. (61 – 89 cm) above the hazard ▶ surface. See **Figure 3-4b.**



HIGH PROXIMITY BACK SHELF PROTECTION WITH THE 2L NOZZLE. AREA OF PROTECTION PER NOZZLE: MAX. LENGTH OF BURNER GRATES 28 IN. (71 cm) AND MAX. AREA OF BURNER GRATES NOT TO EXCEED 336 SQ IN. (2168 sq cm)

Figure 3-4b.

3. Larger Burner Range (784 sq in. (5085 sq cm) maximum, 28 in. (71 cm) longest side maximum)

One nozzle is available for large range protection: High proximity.

The Model 2L nozzle, Part No. 551027, is used for high proximity large range protection. This nozzle is a two (2) flow nozzle. **When using high proximity protection, the range cannot be under a backshelf.** This nozzle must be located 34 in. to 48 in. (86 to 122 cm) above the cooking surface, and aimed directly down within the mounting area, based on the hazard size, as described in the Nozzle Positioning Chart. See **Figure 3-5.**

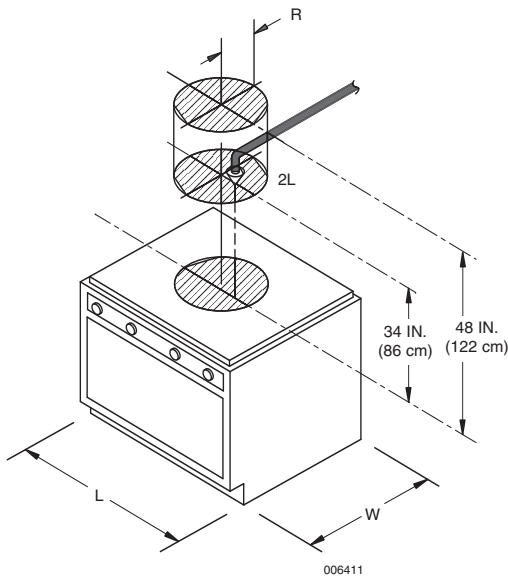

Figure 3-5.

Example: A four burner range has a hazard size of 20 in. (51 cm) in length and 27 in. (69 cm) in width. Follow down the Range Length column in the Nozzle Positioning Chart until you come to 20 in. (51 cm). Continue down this column until the correct width appears in the width column. When the width of 27 in. (69 cm) is arrived at, read across to the radius column to determine the size of radius allowed, for positioning of the nozzle, from the hazard area centerline. In this example, the correct radius is 3 in. (8 cm). The nozzle can be aimed straight down anywhere within a 3 in. (8 cm) radius of the hazard area centerline.

Nozzle Positioning Chart

Range Length - L in. (cm)	Range Width - W in. (cm)	Radius - R in. (cm)
18 (46)	18 (46)	7 1/8 (18)
18 (46)	19 (48)	6 3/4 (17)
18 (46)	20 (51)	6 3/8 (16)
18 (46)	21 (53)	6 (15)
18 (46)	22 (56)	5 5/8 (14)
18 (46)	23 (58)	5 1/4 (13)
18 (46)	24 (61)	4 3/4 (12)
18 (46)	25 (64)	4 3/8 (11)
18 (46)	26 (66)	4 (10)

Range Length - L in. (cm)	Range Width - W in. (cm)	Radius - R in. (cm)
18 (46)	27 (69)	3 5/8 (9)
18 (46)	28 (71)	3 1/8 (8)
19 (48)	18 (46)	6 3/4 (17)
19 (48)	19 (48)	6 3/8 (16)
19 (48)	20 (51)	6 (15)
19 (48)	21 (53)	5 5/8 (14)
19 (48)	22 (56)	5 1/4 (13)
19 (48)	23 (58)	4 7/8 (12)
19 (48)	24 (61)	4 1/2 (11)
19 (48)	25 (64)	4 1/8 (10)
19 (48)	26 (66)	3 3/4 (9)
19 (48)	27 (69)	3 1/4 (8)
19 (48)	28 (71)	2 7/8 (7)
20 (51)	18 (46)	6 3/8 (16)
20 (51)	19 (48)	6 (15)
20 (51)	20 (51)	5 5/8 (14)
20 (51)	21 (53)	5 1/4 (13)
20 (51)	22 (56)	4 7/8 (12)
20 (51)	23 (58)	4 1/2 (11)
20 (51)	24 (61)	4 1/8 (10)
20 (51)	25 (64)	3 3/4 (9)
20 (51)	26 (66)	3 3/8 (8)
20 (51)	27 (69)	3 (7)
20 (51)	28 (71)	2 5/8 (6)
21 (53)	18 (46)	6 (15)
21 (53)	19 (48)	5 5/8 (14)
21 (53)	20 (51)	5 1/4 (13)
21 (53)	21 (53)	5 (12)
21 (53)	22 (56)	4 5/8 (11)
21 (53)	23 (58)	4 1/4 (10)
21 (53)	24 (61)	3 7/8 (10)
21 (53)	25 (64)	3 1/2 (9)
21 (53)	26 (66)	3 1/8 (8)
21 (53)	27 (69)	2 3/8 (7)
21 (53)	28 (71)	2 1/4 (6)
22 (56)	18 (46)	5 5/8 (14)
22 (56)	19 (48)	5 1/4 (13)
22 (56)	20 (51)	4 7/8 (12)
22 (56)	21 (53)	4 5/8 (11)
22 (56)	22 (56)	4 1/4 (10)
22 (56)	23 (58)	3 7/8 (10)
22 (56)	24 (61)	3 1/2 (9)
22 (56)	25 (64)	3 1/8 (8)
22 (56)	26 (66)	2 3/4 (7)
22 (56)	27 (69)	2 3/8 (6)
22 (56)	28 (71)	2 (5)
23 (58)	18 (46)	5 1/4 (13)
23 (58)	19 (48)	4 7/8 (12)
23 (58)	20 (51)	4 1/2 (11)
23 (58)	21 (53)	4 1/4 (10)
23 (58)	22 (56)	3 7/8 (10)
23 (58)	23 (58)	3 1/2 (9)
23 (58)	24 (61)	3 1/8 (8)
23 (58)	25 (64)	2 7/8 (7)
23 (58)	26 (66)	2 1/2 (6)
23 (58)	27 (69)	2 1/8 (5)
23 (58)	28 (71)	1 5/8 (4)

Range Length - L in. (cm)		Range Width - W in. (cm)		Radius - R in. (cm)	
24	(61)	18	(46)	4 3/4	(12)
24	(61)	19	(48)	4 1/2	(11)
24	(61)	20	(51)	4 1/8	(10)
24	(61)	21	(53)	3 7/8	(10)
24	(61)	22	(56)	3 1/2	(9)
24	(61)	23	(58)	3 1/8	(8)
24	(61)	24	(61)	2 7/8	(7)
24	(61)	25	(64)	2 1/2	(6)
24	(61)	26	(66)	2 1/8	(5)
24	(61)	27	(69)	1 3/4	(4)
24	(61)	28	(71)	1 3/8	(3)
25	(64)	18	(46)	4 3/8	(11)
25	(64)	19	(48)	4 1/8	(10)
25	(64)	20	(51)	3 3/4	(10)
25	(64)	21	(53)	3 1/2	(9)
25	(64)	22	(56)	3 1/8	(8)
25	(64)	23	(58)	2 7/8	(7)
25	(64)	24	(61)	2 1/2	(6)
25	(64)	25	(64)	2 1/8	(5)
25	(64)	26	(66)	1 3/4	(4)
25	(64)	27	(69)	1 3/8	(3)
25	(64)	28	(71)	1	(2)
26	(66)	18	(46)	4	(10)
26	(66)	19	(48)	3 3/4	(10)
26	(66)	20	(51)	3 3/8	(9)
26	(66)	21	(53)	3 1/8	(8)
26	(66)	22	(56)	2 3/4	(7)
26	(66)	23	(58)	2 1/2	(6)
26	(66)	24	(61)	2 1/8	(5)
26	(66)	25	(64)	1 3/4	(4)
26	(66)	26	(66)	1 3/8	(3)
26	(66)	27	(69)	1	(2)
26	(66)	28	(71)	3/4	(2)
27	(69)	18	(46)	3 5/8	(9)
27	(69)	19	(48)	3 1/4	(8)
27	(69)	20	(51)	3	(8)
27	(69)	21	(53)	2 3/4	(7)
27	(69)	22	(56)	2 3/8	(6)
27	(69)	23	(58)	2 1/8	(5)
27	(69)	24	(61)	1 3/4	(4)
27	(69)	25	(64)	1 3/8	(3)
27	(69)	26	(66)	1	(2)
27	(69)	27	(69)	3/4	(2)
27	(69)	28	(71)	3/8	(1)
28	(71)	18	(46)	3 1/8	(8)
28	(71)	19	(48)	2 7/8	(7)
28	(71)	20	(51)	2 5/8	(7)
28	(71)	21	(53)	2 1/4	(6)
28	(71)	22	(56)	2	(5)
28	(71)	23	(58)	1 5/8	(4)
28	(71)	24	(61)	1 3/8	(3)
28	(71)	25	(64)	1	(2)
28	(71)	26	(66)	3/4	(2)
28	(71)	27	(69)	3/8	(1)
28	(71)	28	(71)	0	(0)

4. **Small Wok** (24 in. (61 cm) diameter x 6 in. (15 cm) depth maximum)

Two nozzles are available for small wok protection: High proximity and low proximity.

The 1H nozzle, Part No. 551029, is used for high proximity wok protection. This nozzle is a one (1) flow nozzle. The nozzle must be located **anywhere on the perimeter** of the appliance, 24 in. to 48 in. (61 to 122 cm) above the top edge of the wok and aimed at the center of the wok. See **Figure 3-6**.

The 1L nozzle, Part No. 551026, is used for low proximity wok protection. This nozzle is a one (1) flow nozzle. The nozzle must be located **anywhere on the perimeter** of the appliance, 13 in. to 24 in. (33 to 61 cm) above the top edge of the wok and aimed at the center of the wok. See **Figure 3-6**.

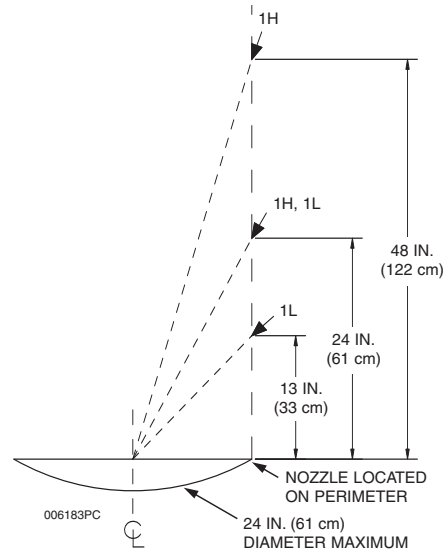

Figure 3-6.

5. Large Wok (Greater than 24 in. to 30 in. (61 to 76 cm) diameter x 8 in. (20 cm) depth maximum)

Two nozzles are available for large wok protection: High proximity and low proximity.

The 2H nozzle, Part No. 551028, is used for high proximity wok protection. This nozzle is a two (2) flow nozzle. The nozzle must be located **anywhere on the perimeter** of the appliance, 24 in. to 48 in. (61 to 122 cm) above the top edge of the wok and aimed at the center of the wok. See **Figure 3-7**.

The 2L nozzle, Part No. 551027, is used for low proximity wok protection. This nozzle is a two (2) flow nozzle. The nozzle must be located **anywhere on the perimeter** of the appliance, 13 in. to 24 in. (33 to 61 cm) above the top edge of the wok and aimed at the center of the wok. See **Figure 3-7**.

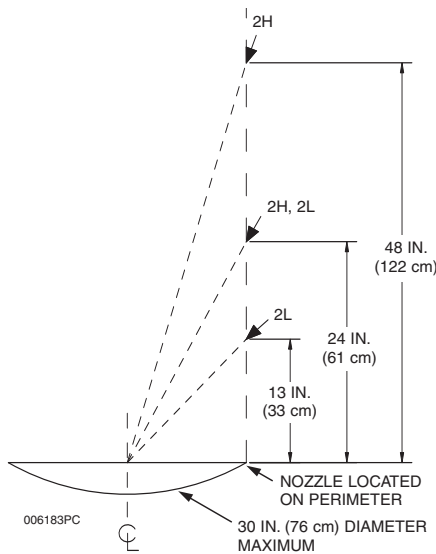

Figure 3-7.

6. Small Griddle (1080 sq in. (6968 sq cm) x 36 in. (91 cm) longest side maximum)

Two nozzles are available for small griddle protection: High proximity and low proximity.

The 1H nozzle, Part No. 551029, is used for high proximity griddle protection. This nozzle is a one (1) flow nozzle. The nozzle must be located **above any corner** of the hazard surface, 24 in. to 48 in. (61 to 122 cm) above the cooking surface of the appliance and aimed at a point 12 in. (31 cm) over and 12 in. (31 cm) in from the corner below the nozzle. See **Figure 3-8**.

The 1L nozzle, Part No. 551026, is used for low proximity griddle protection. This nozzle is a one (1) flow nozzle. The nozzle must be located **above any corner** of the hazard surface, 10 in. to 24 in. (25 to 61 cm) above the cooking surface of the appliance and aimed at a point 12 in. (31 cm) over and 12 in. (31 cm) in from the corner below the nozzle. See **Figure 3-8**.

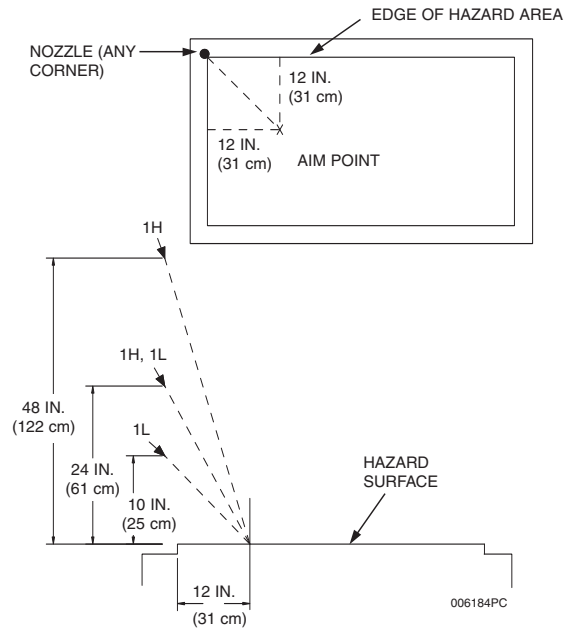

Figure 3-8.

6a. Small Griddle (1080 sq in. (6968 sq cm) x 36 in. (91 cm) longest side maximum) **Alternate Protection**

Two nozzles are available for small griddle **alternate protection**: High proximity and low proximity.

The 2H nozzle, Part No. 551028, is used for high proximity griddle protection. This nozzle is a two (2) flow nozzle. The nozzle must be located 0 to 6 in. (0 to 15 cm) from short side of the hazard surface, 24 in. to 48 in. (61 to 122 cm) above the cooking surface of the appliance and aimed at the center of the hazard area. See **Figure 3-8a**.

The 2L nozzle, Part No. 551027, is used for low proximity griddle protection. This nozzle is a two (2) flow nozzle. The nozzle must be located 0 to 6 in. (0 to 15 cm) from the short side of the hazard surface, 13 in. to 24 in. (33 to 61 cm) above the cooking surface of the appliance and aimed at the center of the hazard area. See **Figure 3-8a**.

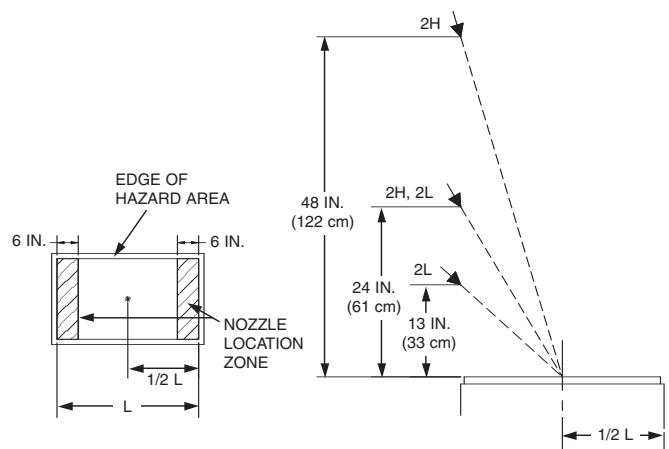

Figure 3-8a.

7. Large Griddle (1440 sq in. (9290 sq cm) x 48 in. (122 cm) longest side maximum)

Two nozzles are available for large griddle protection: High proximity and low proximity.

The 2H nozzle, Part No. 551028, is used for high proximity griddle protection. This nozzle is a two (2) flow nozzle. The nozzle must be located **above any corner** of the hazard surface, 24 in. to 48 in. (61 to 122 cm) above the cooking surface of the appliance and aimed at a point 12 in. (31 cm) over and 12 in. (31 cm) in from the corner below the nozzle. See **Figure 3-9**.

The 2L nozzle, Part No. 551027, is used for low proximity griddle protection. This nozzle is a two (2) flow nozzle. The nozzle must be located **above any corner** of the hazard surface, 10 in. to 24 in. (25 cm to 61 cm) above the cooking surface of the appliance and aimed at a point 12 in. (31 cm) over and 12 in. (31 cm) in from the corner below the nozzle. See **Figure 3-9**.

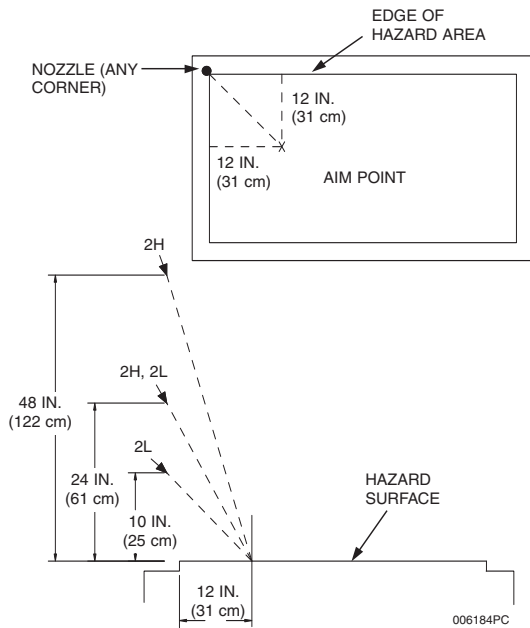

Figure 3-9.

8. Radiant/Electric Char-Broiler (624 sq in. (4026 sq cm) x 26 in. (66 cm) longest side maximum)

Note: Radiant charbroilers are distinguished by the use of heated metal strips (radiants) that are used for cooking.

Two nozzles are available for radiant char-broiler protection. High proximity and low proximity.

The 1H nozzle, Part No. 551029, is used for high proximity radiant char-broiler protection. This nozzle is a one (1) flow nozzle. The nozzle must be located **anywhere within the perimeter** of the hazard area, 24 in. to 48 in. (33 to 61 cm) above the cooking surface of the appliance and aimed at the center of the broiler surface. See **Figure 3-10**.

The 1L nozzle, Part No. 551026, is used for low proximity radiant char-broiler protection. This nozzle is a one (1) flow nozzle. The nozzle must be located **anywhere on the perimeter** of the hazard surface, 13 in. to 24 in. (33 to 61 cm) above the cooking surface of the appliance and aimed at the center of the broiler surface. See **Figure 3-10**.

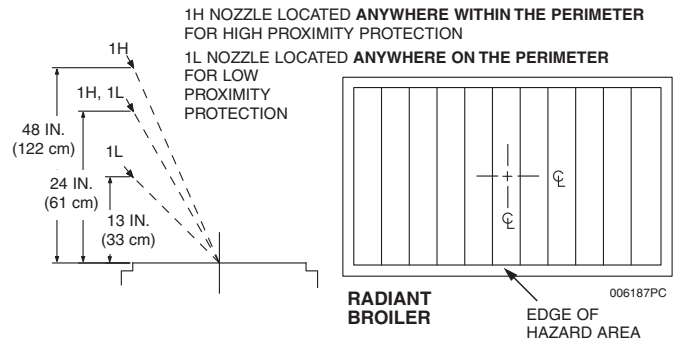

Figure 3-10.

- ▶ **9. Radiant/Electric Char-Broiler** (864 sq in. (2195 sq cm) x 36 in. (91 cm) longest side maximum)

Two nozzles are available for radiant char-broiler protection: High proximity and low proximity.

The 2H nozzle, Part No. 551028, is used for high proximity radiant char-broiler protection. This nozzle is a two (2) flow nozzle. The nozzle must be located **above any corner** of the hazard surface, 36 in. to 48 in. (91 to 122 cm) above the cooking surface of the appliance and aimed at the center of the broiler surface. See **Figure 3-11**.

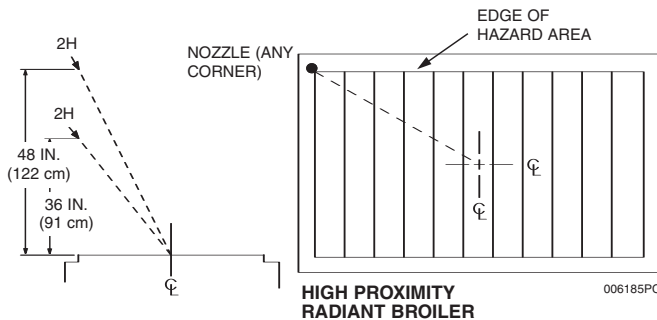

Figure 3-11.

The 2L nozzle, Part No. 551027, is used for low proximity radiant char-broiler protection. This nozzle is a two (2) flow nozzle. The nozzle must be located **anywhere on the perimeter** of the hazard surface, 13 in. to 36 in. (33 to 91 cm) above the cooking surface of the appliance and aimed at the center of the broiler surface. See **Figure 3-11a**.

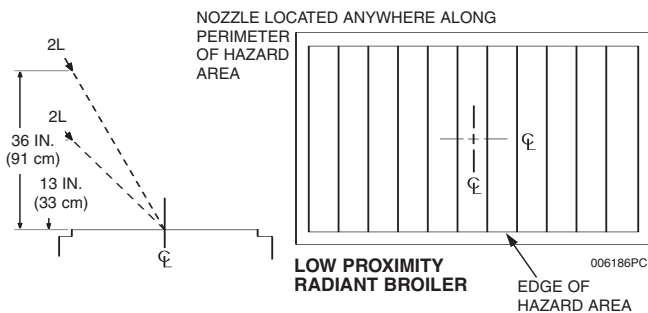

Figure 3-11a.

- ▶ **10. Lava Rock Char-Broiler** (624 sq in. (4026 sq cm) x 26 in. (66 cm) longest side maximum)

Note: Synthetic rock charbroilers are distinguished by the use of lava, pumice, or synthetic rocks that are used for cooking.

One nozzle is available for lava rock char-broiler protection. The 2L nozzle, Part No. 551027, is used for both high proximity and low proximity.

The 2L nozzle, Part No. 551027, is used for high proximity lava rock char-broiler protection. This nozzle is a two (2) flow nozzle. The nozzle must be located **anywhere within the perimeter** of the hazard area, 24 in. to 35 in. (61 to 89 cm) above the cooking surface of the appliance and aimed at the center of the broiler surface. See **Figure 3-12**.

The 2L nozzle, Part No. 551027, is used for low proximity lava rock char-broiler protection. This nozzle is a two (2) flow nozzle. The nozzle must be located **anywhere on the perimeter** of the hazard surface, 15 in. to 24 in. (38 to 61 cm) above the cooking surface of the appliance and aimed at the center of the broiler surface. See **Figure 3-12**.

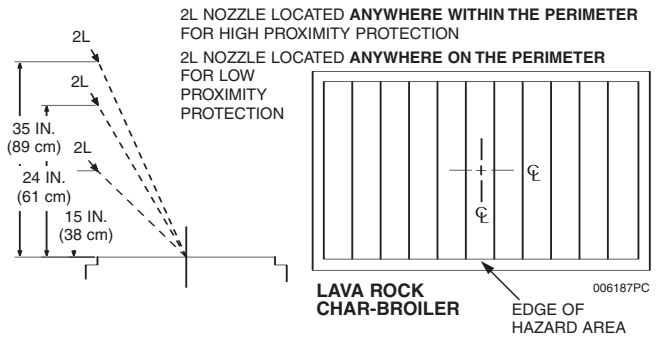

Figure 3-12.

- ▶ **11. Natural Class “A” Charcoal Char-Broiler** (480 sq in. (3097 sq cm) x 24 in. (61 cm) longest side maximum)

Note: Class “A” (natural) charbroilers are distinguished by the use of charcoal, mesquite chips, chunks, and/or logs that are used for cooking.

Two nozzles are available for natural charcoal char-broiler protection. High proximity and low proximity. The maximum depth of fuel (charcoal) must not exceed 6 in. (15 cm).

The 1H nozzle, Part No. 551029, is used for high proximity natural charcoal char-broiler protection. This nozzle is a one (1) flow nozzle. The nozzle must be located **anywhere within the perimeter** of the hazard area, 24 in. to 35 in. (61 to 89 cm) above the cooking surface of the appliance and aimed at the center of the broiler surface. See **Figure 3-13**.

The 1L nozzle, Part No. 551026, is used for low proximity natural charcoal char-broiler protection. This nozzle is a one (1) flow nozzle. The nozzle must be located **anywhere on the perimeter** of the hazard surface, 15 in. to 24 in. (38 to 61 cm) above the cooking surface of the appliance and aimed at the center of the broiler surface. See **Figure 3-13**.

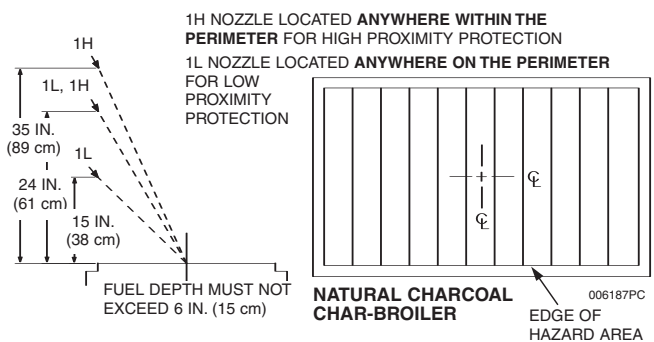

Figure 3-13.

12. Mesquite Char-Broiler (480 sq in. x (3097 sq cm) 24 in. (61 cm) longest side maximum)

Two nozzles are available for mesquite char-broiler protection. High proximity and low proximity. The maximum depth of fuel (wood) must not exceed 6 in. (15 cm).

The 1H nozzle, Part No. 551029, is used for high proximity mesquite char-broiler protection. This nozzle is a one (1) flow nozzle. The nozzle must be located **anywhere within the perimeter** of the hazard area, 24 in. to 35 in. (61 to 89 cm) above the cooking surface of the appliance and aimed at the center of the broiler surface. See **Figure 3-14**.

The 1L nozzle, Part No. 551026, is used for low proximity mesquite charcoal char-broiler protection. This nozzle is a one (1) flow nozzle. The nozzle must be located **anywhere on the perimeter** of the hazard surface, 15 in. to 24 in. (38 to 61 cm) above the cooking surface of the appliance and aimed at the center of the broiler surface. See **Figure 3-14**.

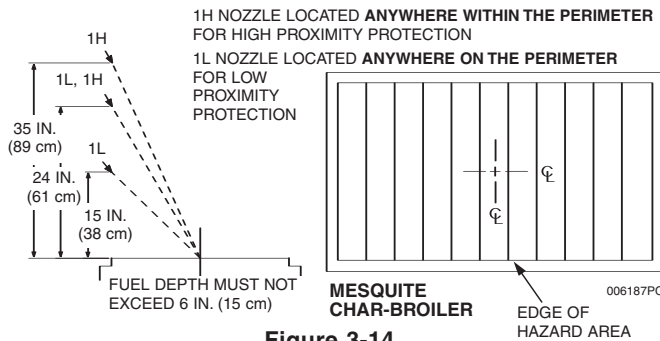

Figure 3-14.

13. Salamander Broiler (internal broiler dimensions of 31 in. (78.7 cm) x 15.5 in. (39.4 cm) and a maximum grate opening of 31 in. (78.7 cm) x 7.75 in. (19.7 cm))

The 1H nozzle, Part No. 551029, is used for broiler protection. This is a one-flow nozzle. The nozzle must be centered 12 to 14 in. (30.5 to 35.5 cm) in front of the salamander and positioned 16 to 18 in. (40.6 to 45.7 cm) above the top of the salamander. The nozzle must be aimed to the center of the opening above the salamander cooking grate. See **Figure 3-15**.

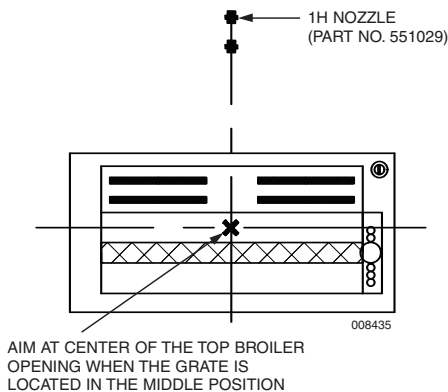

Figure 3-15.

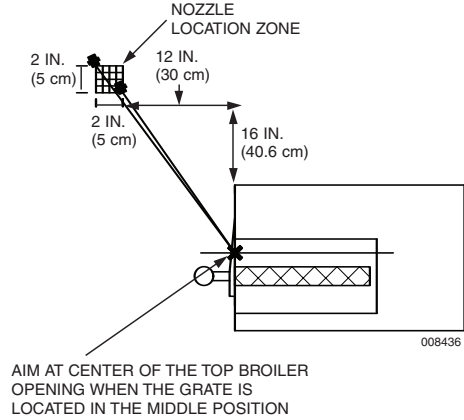

Figure 3-15. (Cont.)

13a. Upright/Salamander Broiler (internal chamber 1064 sq in. x 36 in. (6865 sq cm x 91 cm) longest side maximum)

One nozzle is available for upright/salamander broiler protection.

The 1L nozzle, Part No. 551026, is used for broiler protection. This nozzle is a one (1) flow nozzle. The nozzle must be located above the grate, at the front edge of the appliance, outside the broiling chamber, and pointed at the back opposite corner of the broiler chamber. The nozzle must be aimed parallel to the broiler grate surface. See **Figure 3-15a**.

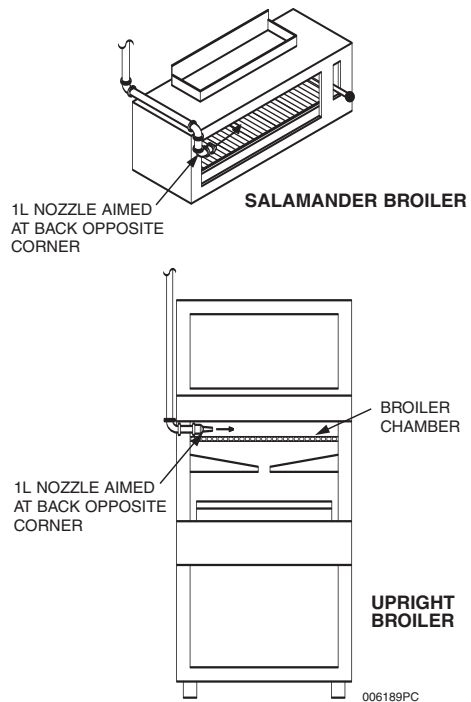

Figure 3-15a.

14. Chain Broiler (internal chamber 1026 sq in. (6619 sq cm) x 38 in. (97 cm) longest side maximum)

One nozzle is available for chain broiler protection.

The 1L nozzle, Part No. 551026, is used for broiler protection. This nozzle is a one (1) flow nozzle. The nozzle must be located 1 to 3 in. (3 to 8 cm) above the surface of the chain, at the front edge of the appliance, and pointed at the opposite diagonal corner. The nozzle must be aimed parallel to the chain surface. See **Figure 3-16**.

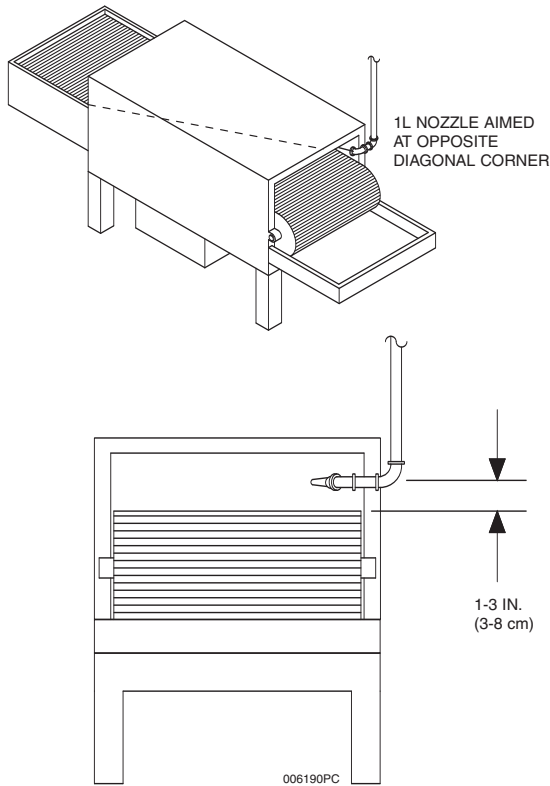
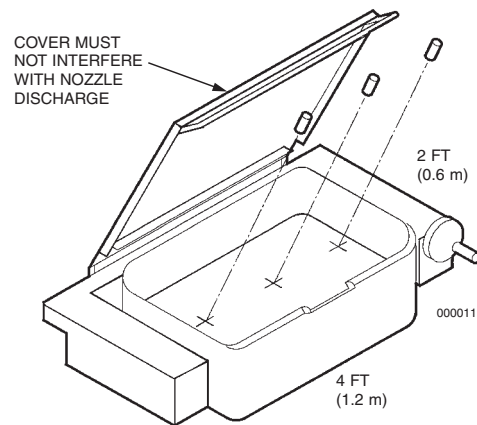

Figure 3-16.

15. Tilt Skillet/Braising Pan

Protection for tilt skillet or braising pans is to be based upon the coverage limitations provided for deep fat fryer protection. Coverage limitations are based on fryer sizes including drip boards. Exception: Tilt skillets and braising pans may exceed the maximum of 6 sq ft (0.6 sq m) total when modularizing. Tilt skillets and braising pans generally utilize a hinged cover. Fryer protection nozzles are to be placed toward the front of the appliance to minimize the potential for the tilt skillet or braising pan cover to interfere with the nozzle discharge. See **Figure 3-17**.



THE NOZZLE IS TO BE PLACED TOWARD THE FRONT OF THE APPLIANCE TO MINIMIZE THE POTENTIAL FOR THE SKILLET OR BRAISING PAN COVER TO INTERFERE WITH THE NOZZLE DISCHARGE.

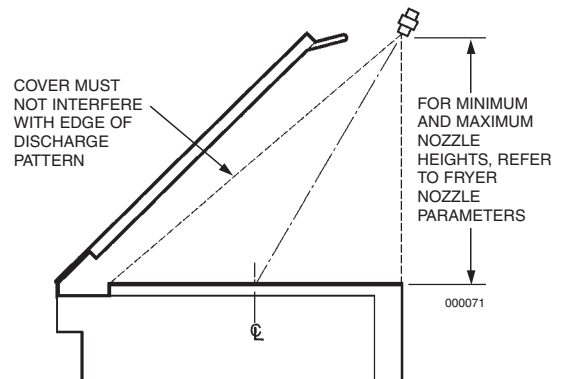

FRYER NOZZLE USED FOR TILT SKILLET OR BRAISING PAN PROTECTION MUST BE POSITIONED NEAR THE FRONT EDGE OF THE PAN AND AIMED AT THE FRONT TO BACK CENTERLINE OF THE PAN. THE DISCHARGE FROM THE NOZZLE(S) MUST COMPLETELY CLEAR THE PAN COVER WITH AN UNOBSTRUCTED VIEW TO THE BACK OF THE PAN.

Figure 3-17.

► Henny Penny Fryer – Mono Rail Center Lift System – Models 690, 691, 692

- **Nozzle Type:** (1) One – 2H, Part No. 553390 (upper position) and (1) One – 2F, Part No. 553328 (lower position)
- **Nozzle Location:**

2H Nozzle (upper position): From the Tee Block, Part No. 434424; nozzle tip located 16 in. (40.6 cm) up from base of fryer surface and 5 in. (12.7 cm) in from **right side of appliance back shroud** – aimed to discharge at center point of fry vat.

2F Nozzle (lower position): Running down from the Tee Block to the base of the fryer, nozzle tip is located 2 in. (5.1 cm) from back side of fry vat, and 8 in. (20.3 cm) in from the **right side of appliance back shroud**. **The 2F nozzle is a flat spray nozzle and the spray must be horizontal to that of the edge of the back lip of the fry vat.**

- **System Coverage:**

Each fryer requires a minimum of one PCL 300 Agent Tank discharging through the two two-flow nozzles (2H and 2F).
- **Piping Limitations** – Follow the limitations for the PCL 300 Agent Tank.

Henny Penny Mono Rail Center Lid Lift System – Models 690, 691, 692

NOTE: VAT DIMENSIONS –
 16 IN. (40.6 cm) WIDE
 20 1/4 IN. (51.4 cm) LENGTH
 28 1/2 IN. (72.4 cm) DEPTH
 MAXIMUM LID HEIGHT ABOVE VAT
 15 IN. (38.1 CM)

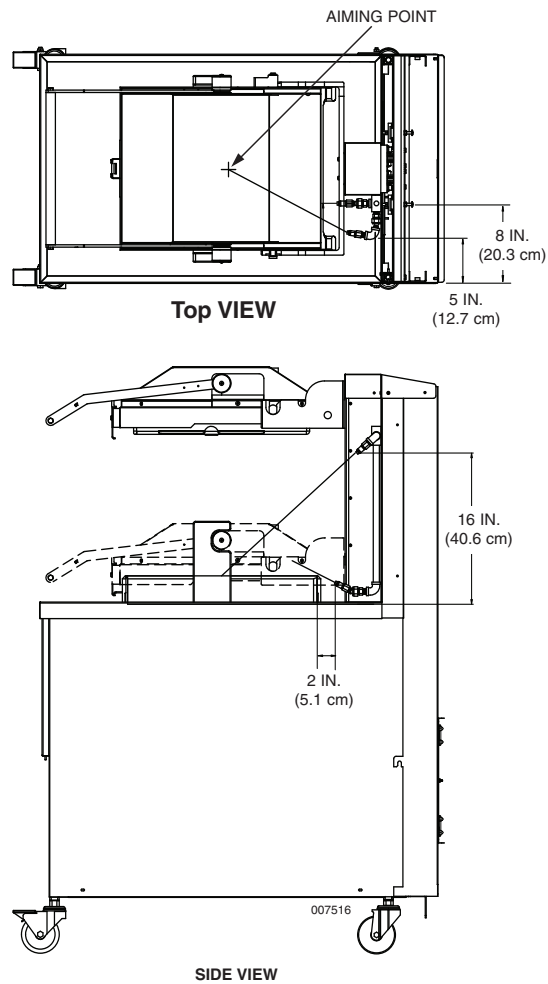
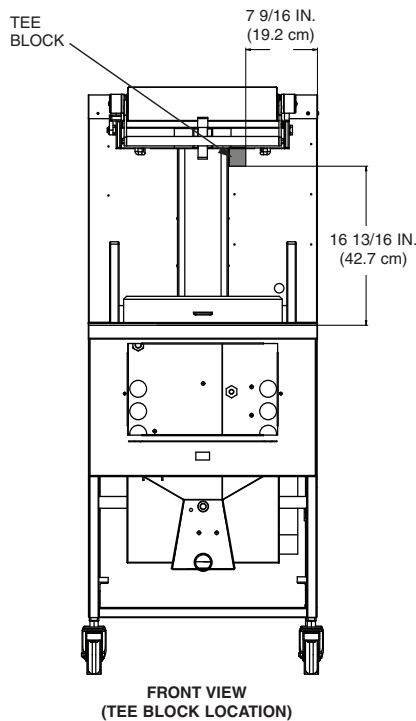

Figure 3-17a.

Henny Penny Fryer – Dual Lift System – Models 580, 581, 582, 590, 591, 592, 680, 682

- **Nozzle Type:** (1) One – 2H, Part No. 553390 (upper position) and (1) One – 2F, Part No. 553328 (lower position)

- **Nozzle Location:**

2H Nozzle (upper position): From the Tee Block, Part No. 434424; nozzle tip located 16 in. (40.6 cm) up from base of fryer surface and 5 in. (12.7 cm) in from **left side of appliance back shroud** – aimed to discharge at center point of fry vat.

2F Nozzle (lower position): Running down from the Tee Block to the base of the fryer, nozzle tip is located 2 in. (5.1 cm) from back side of fry vat, and 8 in. (20.3 cm) in from the **left side of appliance back shroud**. The **2F nozzle is a flat spray nozzle and the spray must be horizontal to that of the edge of the back lip of the fry vat.**

- **System Coverage:**

Each fryer requires a minimum of one PCL 300 Agent Tank discharging through the two two-flow nozzles (2H and 2F).

- **Piping Limitations** – Follow the limitations for the PCL 300 Agent Tank.

Henny Penny Dual Lift System – Models 580, 581, 582, 590, 591, 592, 680, 682

NOTE: VAT DIMENSIONS –
16 IN. (40.6 cm) WIDE
20 1/4 IN. (51.4 cm) LENGTH
28 1/2 IN. (72.4 cm) DEPTH
MAXIMUM LID HEIGHT ABOVE VAT
15 IN. (38.1 CM)

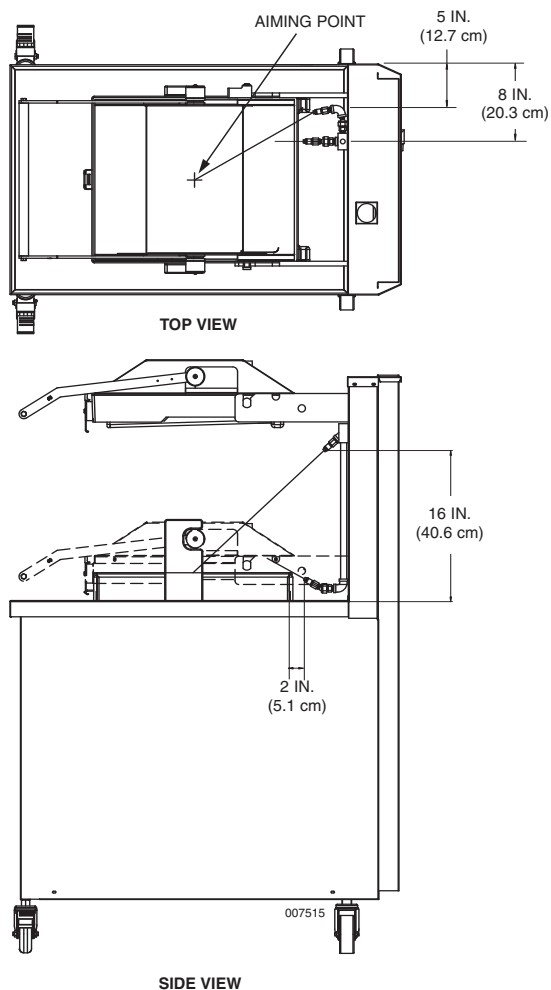
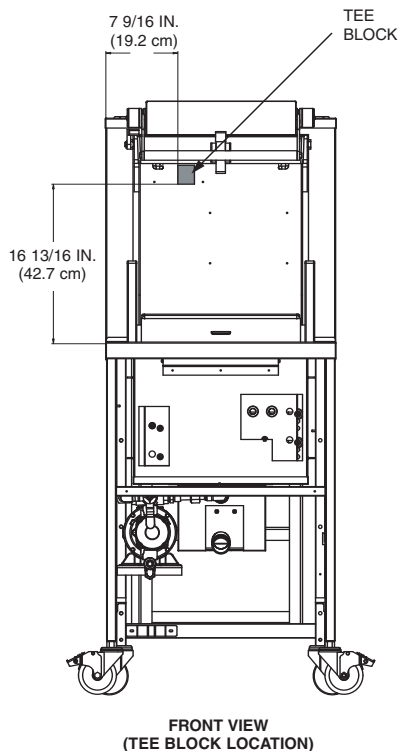
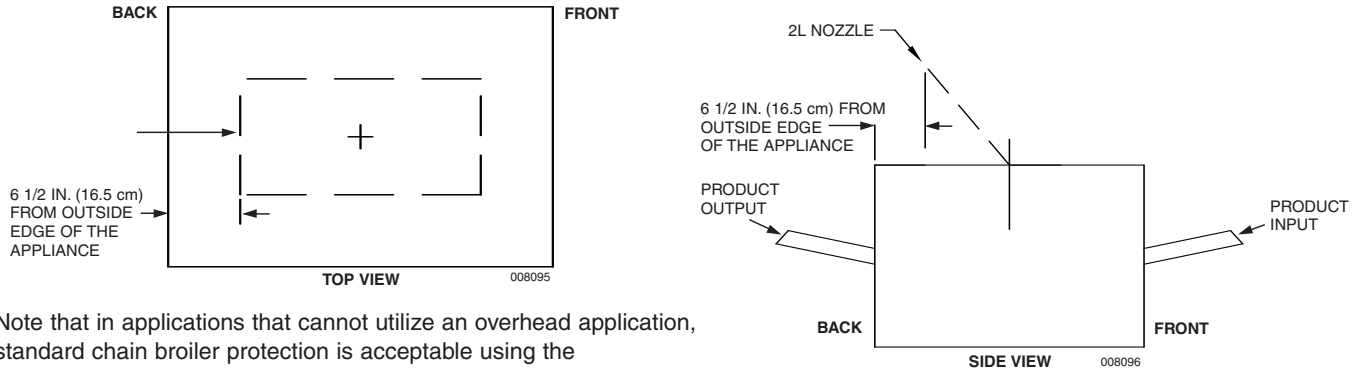

Figure 3-17b.

Nieco Broiler – Model MPB 84 with Catalyst ONLY

- Nozzle Type:** 2L
- Nozzle Quantity:** One
- Nozzle Height:** 20 in. (50.8 cm)
- Nozzle Location:** 6.5 in (16.5 cm) from any edge of the appliance top
- Nozzle Direction:** Aim at center of opening



Note that in applications that cannot utilize an overhead application, standard chain broiler protection is acceptable using the 1L Nozzle installed at the opening.

Figure 3-17c.

Nieco Broiler – Model JF94E Electric Broiler with Catalyst

High Proximity Protection

- Nozzle Type:** 2H
- Nozzle Quantity:** Two
- Nozzle Height:** 20 in. (50.8 cm)
- Nozzle Location:** 6.5 in. 16.5 cm) from front or back edge of hazard
 Nozzles positioned 15 in. (38.1 cm) apart
- Nozzle Aim Point:** Center of catalyst

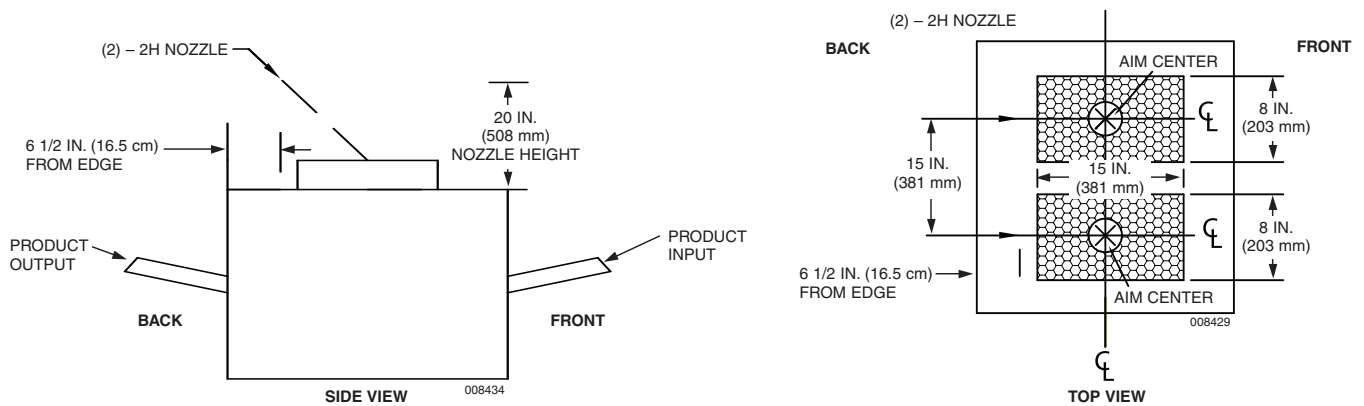

Figure 3-17d.

(Page Intentionally Left Blank)

Fryer – Multiple Nozzle Protection

Fryers exceeding the coverage of a single nozzle can be divided into modules. Each module must not exceed the maximum area allowed for a single nozzle. However, when utilizing multiple nozzle protection, the longest side allowed for a fryer with drip board can be used, regardless of whether the fryer has a drip board or not.

The maximum size fryer that can be modularized is 864 sq in. (5574 sq cm).

Design requirements for multiple nozzle fryers are broken down as follows:

1. If the fryer includes any dripboard areas, measure both the internal length (front to back) and width of the frypot portion. Then measure the internal length and width of the overall hazard area including any dripboard areas.

Determine the area of both the frypot and the area of the overall vat by multiplying corresponding length and width dimensions.

2. Divide the frypot or overall vat into modules, each of which can be protected by a single nozzle, based on the maximum dimension and area coverage of the nozzle as specified in "Design Chart."

- If the module considered does not include any portion of the dripboard, use only the maximum frypot area and maximum dimension listed in the "Design Chart."
- If the module considered includes any dripboard areas, use both the maximum frypot area and dimension listed in the "Design Chart", and the maximum overall area and dimension listed in the "Design Chart."

3. None of the maximum dimensions may be exceeded. If either the maximum frypot or the overall sizes are exceeded, the area divided into modules will need to be redefined with the possibility of an additional nozzle.

Design Chart

	Longest Side	Vat Coverage	Coverage with Drip
Option 1	27 3/4 in. (70.5 cm)	324 in ² (2090 cm ²)	500 in ² (3226 cm ²)
Option 2	25 3/8 in. (64.5 cm)	371 in ² (2394 cm ²)	495 in ² (3194 cm ²)

PIPING LIMITATIONS

Once the nozzle placement and quantity of tanks has been determined, it is necessary to determine the piping configurations between the tank and the nozzles. This section contains the guidelines and limitations for designing the distribution piping so that the wet chemical agent will discharge from the nozzles at a proper flow rate. These limitations must also be referred to when selecting the mounting location for the tanks.

The maximum pipe lengths are based on internal pipe volume. Each size tank is allowed a minimum and maximum total volume of piping, calculated in milliliters.

There is no need to distinguish between what portion of the piping is supply line and what portion is branch line. Only the total volume of the complete piping network has to be considered.

Volume Chart

1/4 in. pipe = 20.5 mls/ft
3/8 in. pipe = 37.5 mls/ft
1/2 in. pipe = 59.8 mls/ft
3/4 in. pipe = 105.0 mls/ft

Tank Chart

Tank Size	Maximum Flow Numbers	Maximum Pipe Volume (milliliters)	*Maximum Volume Allowed Between First Nozzle and Last Nozzle (milliliters)
1.6 Gallon PCL-160	5	1500	600
3.0 Gallon PCL-300	10	1910	1125
4.6 Gallon PCL-460	14	3400	3000
4.6 Gallon PCL-460	15	2600	2000
6.0 Gallon PCL-600	19	4215	1688 per side
6.0 Gallon PCL-600	20	3465	1313 per side

- * All piping, including nozzle drops, must be included in the piping calculations.

Minimum Pipe Volumes for a Fryer, Range, and Wok		
Cylinder Size	Entire System	At or before appliance
PCL 160	239 ml - 1 Flow Pt	180 ml - 1 Flow Pt
PCL 300	300 ml - 4 Flow Pts	239 ml - 2 Flow Pts
PCL 460	660 ml - 10 Flow Pts	180 ml - 2 Flow Pts
PCL 600	960 ml - 14 Flow Pts	120 ml - 2 Flow Pts

General Piping Requirements

1. Split piping and straight piping are both allowed on a PCL-160, PCL-300 and PCL-460 system.
2. PCL-600 systems must use split piping only, with no nozzle located before the split, and with a maximum of 14 flow points per side. 1/2 in. minimum piping must be used up to the first split.
3. Maximum volume for 1/4 in. pipe between a nozzle and the preceding tee is 410 mls.
4. Maximum flow numbers for 1/4 in. pipe is 6.
5. Maximum number of elbows between a nozzle and the preceding tee is 5.
6. Maximum of 25 elbows are allowed in the total piping system.
7. Maximum difference in elevation between the tank outlet and any nozzle, or the tank outlet and the highest or lowest horizontal pipe run, is 10 ft (3.1 m).
8. No traps are allowed in the piping network.
9. Pipe lengths are measured from center to center of fittings.
10. The internal equivalent length volume of fittings does not have to be considered as part of the total pipe volume.
11. When utilizing different size pipe in the system, the largest size must start first and the additional pipe must decrease as it approaches the nozzle.
12. Elbow(s) or swivel adaptors located at the nozzles do not have to be counted in the 25 elbow maximum requirement.
13. Reducing bushings are allowed when reducing to a smaller pipe size.
14. Additional piping requirements when protecting a range, wok, or a fryer:
 - PCL-160 – Minimum of 239 ml and one (1) flow number required in total system. Of that minimum, 180 ml must be utilized at or before the range, wok, or fryer.
 - PCL-300 - Minimum of 300 ml and four (4) flow numbers required in total system. Of that minimum, 239 ml and two (2) flow numbers must be utilized at or before the range, wok, or fryer.
 - PCL-460 – Minimum of 660 ml and ten (10) flow numbers required in total system. Of that minimum, 180 ml and two (2) flow numbers must be utilized at or before the range, wok, or fryer.
 - PCL-600 – Minimum of 960 ml and fourteen (14) flow numbers required in total system. Of that minimum, 120 ml and 2 flow numbers must be utilized at or before the range, wok, or fryer.

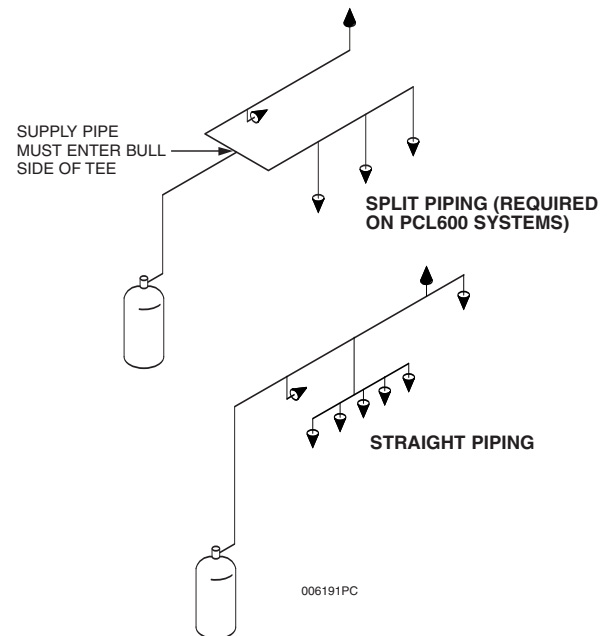

Figure 3-18.

Design Steps

- Step No. 1** Determine number of flow points required based on duct size, plenum size and type, and size of all appliances.
- Step No. 2** Determine size and quantity of tanks required. Refer to the chart in "General Piping Requirements" to determine the maximum amount of flow numbers allowed per each tank size.
- Step No. 3** Layout nozzles, piping diagram, and tank location. Determine pipe lengths as accurate as possible. Make certain maximum number of elbows is not exceeded. **Note: Tanks cannot be manifolded together. Each tank must have a separate piping network.**
- Step No. 4** Add all the lengths of each pipe run and multiply by the mls./ft. listed in the Volume Chart. If the sum falls within the acceptable range noted in general Piping Requirements, that pipe size is acceptable. If the calculated volume is too large, recalculate the volume using the ml per foot of a smaller pipe size. Pipe sizes can be mixed but Rule No. 11 of the General Piping Requirements must be followed.
- Step No. 5** Check to make certain minimum volumes, maximum volumes and maximum volume allowed between first nozzle and last nozzle is not exceeded (Tank Chart). Check each rule in "General Piping Requirement" to make certain none have been exceeded. If any requirement is exceeded, change to a different pipe size and recalculate.

Example

The cooking area that requires protection consists of a single 56 in. (142 cm) perimeter exhaust duct, a 10 ft (3.1 m) long "V" bank plenum, (2) 18 in. (46 cm) wide x 24 in. (61 cm) fryers, a 30 in. (76 cm) x 36 in. (91 cm) wide griddle, and a 24 in. (61 cm) diameter wok. See **Figure 3-19**.

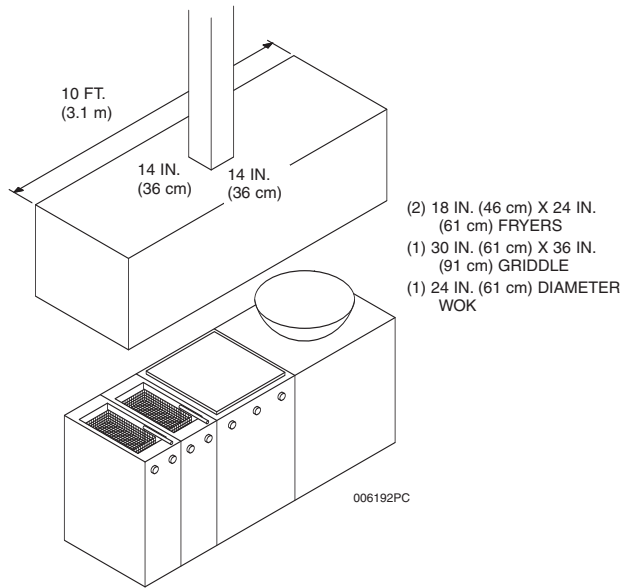

Figure 3-19.

Step No. 1 Determine number of flow points required.

- 56 in. (142 cm) perimeter duct requires one, **two flow** nozzle
- 10 ft (3.1 m) "V" bank hood requires one, **one flow** nozzle
- 18 in. x 24 in. (46 x 61 cm) fryer requires one, **two flow** nozzle
- 18 in. x 24 in. (46 x 61 cm) fryer requires one, **two flow** nozzle
- 30 in. x 36 in. (76 x 91 cm) griddle requires one, **one flow** nozzle
- 24 in. (61 cm) diameter wok requires one, **one flow** nozzle

TOTAL FLOW NUMBERS – 9

Step No. 2 Determine size and quantity of tanks required. Referring to the chart in "General Piping Requirements," a PCL-300 and a PCL-460 can supply 10 flows, therefore, a PCL-300 can be utilized.

Step No. 3 Make an accurate sketch of the cooking lineup and the hood. Sketch in the tank location and all the piping required for the total system. Make certain all pipe lengths and number of elbows are as accurate as possible. Check the "General Piping Requirements" to determine that the minimum and maximum requirements are met. See **Figure 3-20**.

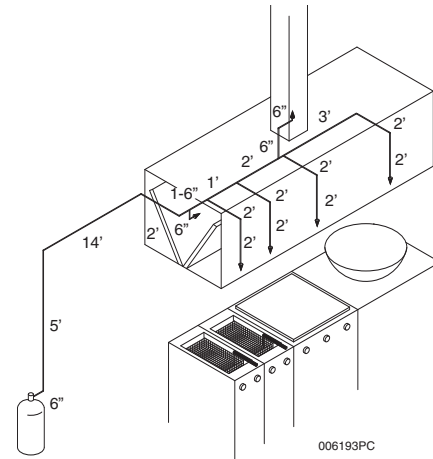

Figure 3-20.

Step No. 4 Total all pipe lengths. Refer to the Volume Chart. Chose a given pipe size and multiply the ml per foot by the total length of all the pipe. If the sum falls within the acceptable range noted in Tank Chart, that pipe size is acceptable. If the calculated volume is too large, recalculate the volume using the ml per foot of a smaller pipe size. See **Figure 3-21**.

Add section A-B = $0'-6" + 5' + 14' + 2' + 0'-6" = 22'$ ($0.2 + 1.5 + 4.3 + 0.6 + 0.2 = 6.8$ m)

Add section B-C = $1'-6" (0.5$ m)

Add section C-D = $1' (0.3$ m)

Add section D-E = $2' (0.6$ m)

Add section E-F = $0'-6" (0.2$ m)

Add section F-L = $3' + 2' + 2' = 7' (2.1$ m)

Add section B-G = $0'-6" (0.2$ m)

Add section C-H = $2' + 2' = 4' (0.6 + 0.6 = 1.2$ m)

Add section D-I = $2' + 2' = 4' (0.6 + 0.6 = 1.2$ m)

Add section E-J = $0'-6" + 0'-6" = 1' (.3$ m)

Add section F-K = $2' + 2' = 4' (0.6 + 0.6 = 1.2$ m)

Total length of all pipe = $47'-6" (14.5$ m)

Refer to Volume Chart. The pipe size chosen is 3/8 inch. The volume per foot of 3/8 in. pipe is 37.5 ml. Multiply 37.5 by the total pipe length of 47.5 ft.

37.5 ml x 47.5 ft = 1781 ml total volume

The maximum volume allowed for a PCL-300 is 1910 ml, therefore, 3/8 in. pipe is acceptable for this system.

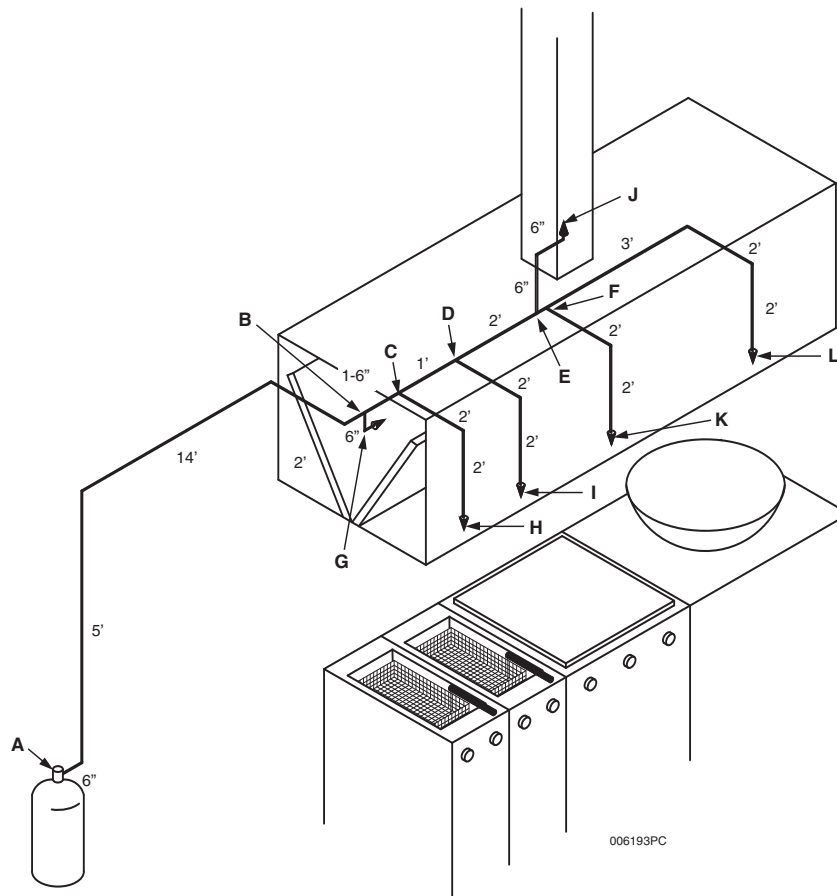

Figure 3-21.

Step No. 5 Check to make certain minimum volumes and maximum volume allowed between first nozzle and last nozzle are not exceeded (Tank Chart). Check each rule in "General Piping Requirements" to make certain none have been exceeded. If any requirement is exceeded, change to a different pipe size and recalculate. See **Figure 3-22**.

Refer to Tank Chart

Minimum Pipe Volume for PCL-300 is 300 milliliters protecting a fryer, wok, or range
 (Example system pipe volume is 1781 milliliters, therefore OK)

Maximum Pipe Volume for PCL-300 is 1910 milliliters (Example system pipe volume is 1781 milliliters, therefore OK)

Maximum Volume Allowed Between First Nozzle and Last Nozzle for PCL-300 is 1125 milliliters (Example system, the amount of 3/8 in. piping between G and L, is 25.5 feet. 25.5 feet x 37.5 mls/ft = 956.3 ml, therefore, OK)

Refer to General Piping Requirements

1. **Split piping and straight piping are both allowed on PCL-300 and PCL-460 systems.** (Example system OK)
2. **PCL-600 systems must use split piping only, with no nozzle located before the split, and with a maximum of 14 flow points per side. 1/2 in. minimum piping must be used up to the first split.** (Example system N/A)
3. **Maximum volume for 1/4 in. pipe between a nozzle and the preceding tee is 410 mls.** (Example system N/A)
4. **Maximum flow numbers for 1/4 in. pipe is 6.** (Example system N/A)
5. **Maximum number of elbows between a nozzle and the preceding tee is 5.** (Example system has a maximum number of 2, therefore, OK)
6. **Maximum of 25 elbows are allowed in the total piping system.** (Example system has 11 elbows, therefore, OK)
7. **Maximum difference in elevation between the tank outlet and any nozzle, or the tank outlet and the highest or lowest horizontal pipe run, is 10 ft (3.1 m)** (Example system has 5'-6" (1.7 m), therefore, OK)
8. **No traps are allowed in the piping network.** (Example system has no traps, therefore, OK)
9. **Pipe lengths are measured from center to center of fittings.** (Example system pipe lengths were measured from center to center of fittings, therefore, OK)

10. **The internal equivalent length volume of fittings does not have to be considered as part of the total pipe volume.** (Example system OK)

11. **When utilizing different size pipe in the total system, the largest size must start first and the additional pipe must decrease as it approaches the nozzle.** (Example system N/A)

12. **Elbow(s) or swivel adaptors located at the nozzles do not have to be counted in the 25 elbow maximum requirement.** (Example system OK)

13. **Additional piping requirements when protecting a range, wok, or a fryer:**
- **PCL-300 - Minimum of 300 ml and four (4) flow numbers required in total system. Of that minimum, 239 ml and two (2) flow numbers must be utilized at or before the range, wok, or fryer.** (Example system has 1781 ml and 10 flow numbers, therefore, OK. The example system has 1050 ml and 3 flows including the fryer, therefore, OK)
 - **PCL-460 – Minimum of 660 ml and ten (10) flow numbers required in total system. Of that minimum, 180 ml and two (2) flow numbers must be utilized at or before the range, wok, or fryer.**
 - **PCL-600 – Minimum of 960 ml and fourteen (14) flow numbers required in total system. Of that minimum, 120 ml and 2 flow numbers must be utilized at or before the range, wok, or fryer.**

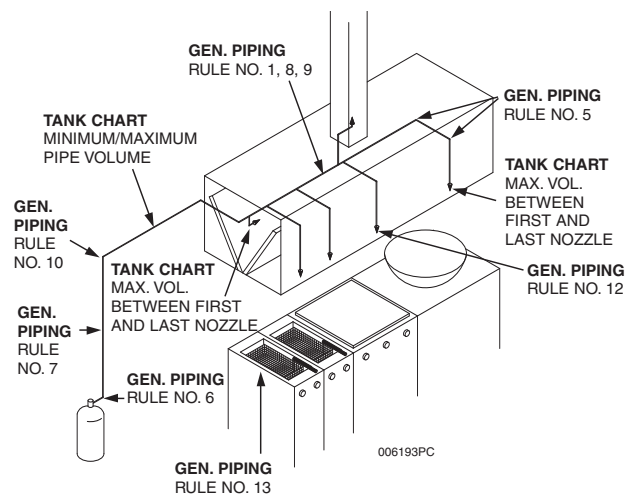

Figure 3-22.

DETECTOR PLACEMENT

Detectors are required over cooking appliances and in the
▶ duct(s) of protected ventilation hoods.

Exhaust Duct(s).

Each exhaust duct must have at least one (1) detector installed in the duct entrance, located in the air stream of the cooking vapors at a maximum of 12 ft (3.7 m) into the duct. See **Figure 3-23**.

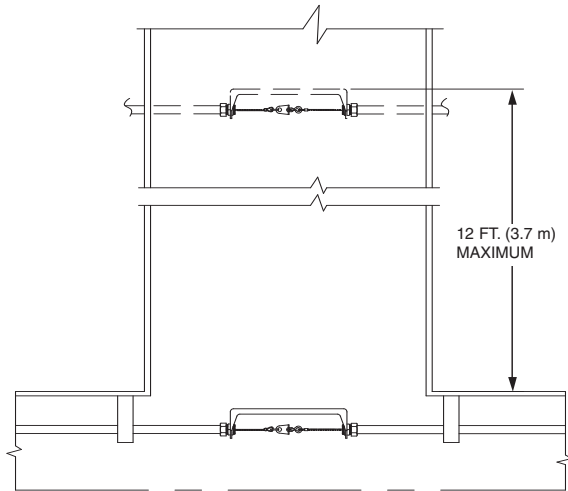

Figure 3-23.

006884PC

NOTICE

When gas appliances are used and the flue gases from the burner are exhausted into the duct, the detector must be kept out of the air stream of these exhaust gases. These gases can be very hot and could actuate the system unnecessarily.

Duct openings that are long and narrow or large enough to require multiple duct nozzles may require additional detectors.

Electrostatic Precipitator.

If an electrostatic precipitator is located at or near the base of the exhaust duct, it is necessary to locate a detector below the precipitator, at the base of the duct, and also locate one in the duct, just above the precipitator. See **Figure 3-23a**.

When installing the detector bracket and system conduit, make certain they do not interfere with the operation of the precipitator.

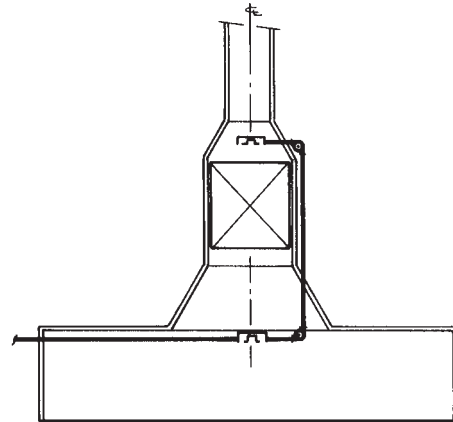

Figure 3-23a.

000268

Cooking Appliance(s).

Each cooking appliance with a continuous cooking surface not exceeding 48 in. x 48 in. (122 x 122 cm) shall be protected by one (1) detector. Cooking appliances with a continuous cooking surface exceeding 48 in. x 48 in. (122 x 122 cm) shall be protected by one (1) detector per 48 in. x 48 in. (122 x 122 cm) cooking area. Detectors used for cooking appliances must be located above the protected appliance toward the exhaust duct side of the appliance. The detector should be located in the air stream of the appliance to enhance system response time.

► If the cooking appliance is located under an exhaust duct where a detector has been mounted, it is normally not necessary to utilize another detector for that cooking appliance, provided the detector is not more than 12 in. (30 cm) into the duct and the appliance has no larger cooking surface than 48 in. x 48 in. (121.9 cm x 129.1 cm). See **Figure 3-24**.

Note: If two (2) appliances are located under a duct opening where a detector has been mounted and both appliances together do not exceed a cooking surface of 48 in. x 48 in. (121.9 cm x 121.9 cm) and the detector is located above both the protected appliances, it is not necessary to utilize an additional detector provided the duct detector is not more than 12 in. (30.5 cm) into the duct opening.

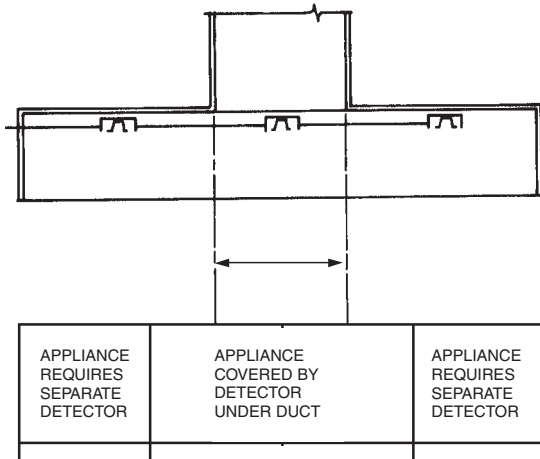

Figure 3-24. Proper Detector Placement.

000269

Each cooking appliance with a continuous cooking surface not exceeding 48 in. x 48 in. (122 x 122 cm) can be protected by a minimum of **one** detector. Cooking appliances with a continuous cooking surface exceeding 48 in. x 48 in. must be protected by at least **one detector per 48 in. x 48 in. cooking area**.

Detectors used for cooking appliances must be located above the protected appliance toward the exhaust duct side of the appliance. The detector should be located in the air stream of

► the appliance to enhance system response time.

CHAPTER IV SYSTEM INSTALLATION

GENERAL

▶ The installation information listed in this section deals with the limitations and parameters of this pre-engineered system. Those individuals responsible for the installation of the KITCHEN KNIGHT II system must be trained and hold a current PYRO-CHEM certificate in a KITCHEN KNIGHT II training program.

Pipe and fittings for the discharge piping, conduit (EMT), pipe straps, pipe hangers, mounting bolts, and other miscellaneous equipment are not furnished as part of the PYRO-CHEM KITCHEN KNIGHT II Restaurant Fire Suppression System. These items must be furnished by the installer.

Before attempting any installation, unpack the entire system and check that all necessary parts are on hand. Inspect parts for damage. Verify that cylinder pressure is within the acceptable range as shown on the gauge.

CYLINDER INSTALLATION

The cylinder and valve assembly is shipped with an anti-recoil plug in the valve discharge port.

CAUTION

The anti-recoil plug must remain in the valve discharge port until the discharge piping is connected to the valve.

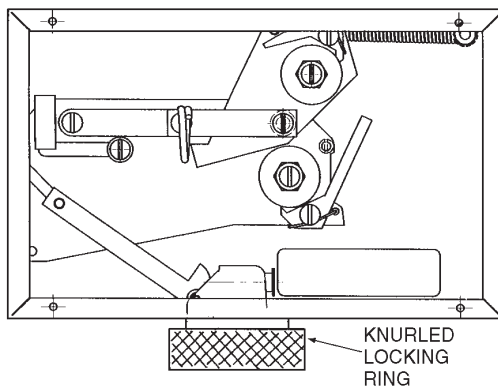

Figure 4-2. Single Cylinder Installation Using Model ECH3/MCH3/NMCH3 Control Head.

006214PC / 003647PC

The cylinder must be mounted vertically. The Models PCL-300 and PCL-460 cylinders must be mounted using a Model MB-15 Mounting Bracket Kit. The Model PCL-600 cylinder must be mounted using a Model MB-1 Mounting Bracket Kit.

The bracket must be securely anchored to the wall using bolts or lag screws. The wall to which the bracket is attached must be sufficiently strong to support the cylinder. The bracket should never be fastened to dry wall or similar material. If this type of wall is encountered, studs must be located and the bracket fastened to them. See **Figure 4-1**.

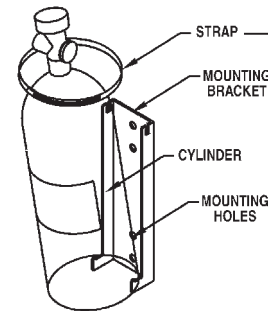

Figure 4-1. Cylinder and Mounting Bracket Installation.

002945PC

CONTROL HEAD INSTALLATION

Single Cylinder Installation

For single cylinder system installations the Model MCH3/ECH3/NMCH3 Control Head can be installed directly onto the cylinder valve. When the control head is properly aligned in the desired position, tighten the knurled locking ring to secure the assembly. See **Figure 4-2**.

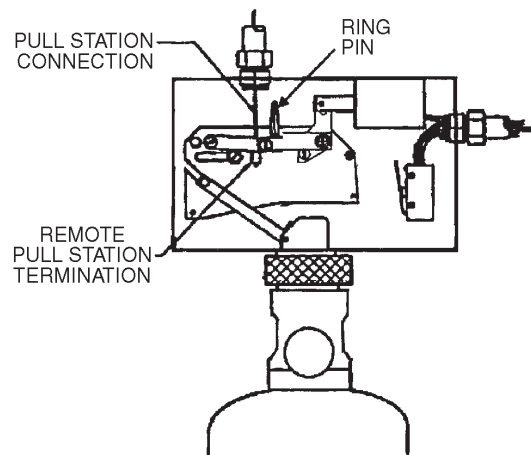

Multiple Cylinder Installation

1. Multiple Cylinder Actuation Using MCH3/ECH3/NMCH3 Control Head

The Model MCH3/ECH3/NMCH3 Control Head can be used to pneumatically actuate a maximum of five (5) agent cylinders with a 16 gram CO₂ cartridge. When a control head is used for multiple cylinder actuation, it cannot be mounted directly onto a cylinder valve. The control head must be installed remotely using a Model MB-P2 Control Head Mounting Bracket. The bracket must be anchored to the wall using bolts or lag screws.

CAUTION

Do not screw the control head directly to a wall as this will warp the control head, not allowing the mechanism to actuate.

In order to actuate the agent cylinder(s) from a control head, a 1/4 in. NPT x 45° 1/4 in. flare type fitting (conforming to SAE J513c) or male straight connector (Part No. 32338) must be screwed into the base of the control head actuator. Pneumatic tubing or stainless steel actuation hose is then used to connect the control head to the valve cap assembly of each agent cylinder valve. See **Figure 4-3**.

NOTE

Pneumatic tubing (copper) used for remote cylinder actuation shall have an outside diameter of 1/4 in. with a minimum wall thickness of 1/32 in. This is commonly known as refrigeration-type copper tubing. All tubing fittings shall be of the 1/4 in., 45° flare type conforming to SAE J513c.

Compression type fittings are not acceptable.

A single Model MCH3/ECH3/NMCH3 Control Head can actuate:

1. Up to four (4) cylinders with a maximum of 25 ft (7.6 m) of copper or stainless steel pneumatic tubing or stainless steel actuation hose when using an O-ring (PN 55531) installed in place of the Teflon washer and the 16 gram CO₂ cartridge.
2. Up to five (5) cylinders with a maximum of 18 ft (5.4 m) of copper or stainless steel pneumatic tubing or stainless steel actuation hose when using an O-ring (PN 55531) installed in place of the Teflon washer and the 16 gram CO₂ cartridge.

CAUTION

Confirm the Teflon washer in the control head actuator assembly has been replaced with the O-ring (PN 55531) and the 16 gram CO₂ cartridge is installed for 4 and 5 cylinder single control head actuation.

The actuation line must be tested for any leaks by using a hand held or electric vacuum pump. The pump should be used to draw a vacuum on the actuation line at the fitting closest to the control head. A vacuum should be pulled to 20 inches of mercury. Leaks exceeding 5 inches of mercury within 30 seconds are not allowed. If the gauge on the vacuum pump indicates a leak in the line, examine the actuation line for loose fittings or damage. Correct any leaks and retest.

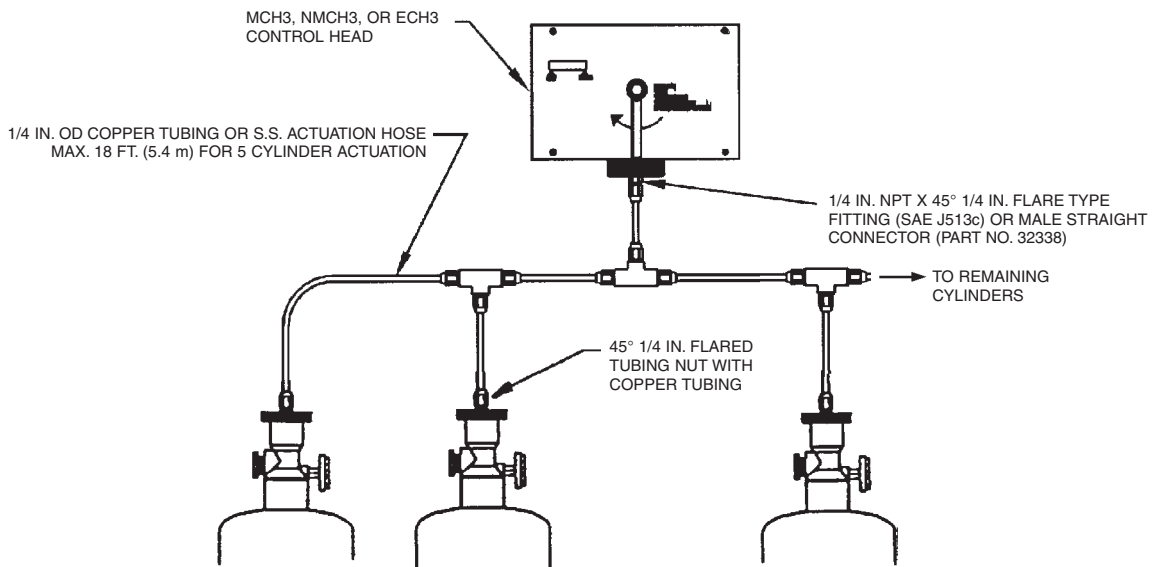

Figure 4-3. Multiple Cylinder Actuation Using Model MCH3/ECH3/NMCH3 Control Head.

004428PC

2. Multiple Cylinder Actuation Using Model PAC-10 Pneumatic Actuation Cylinder

The Model PAC-10 Pneumatic Actuation Cylinder must be used if more than five (5) agent cylinders require simultaneous actuation. The Model PAC-10 must be used in conjunction with a Model MCH3/ECH3/NMCH3 Control Head. The control head is mounted on the Model PAC-10 valve assembly.

The Model PAC-10 is shipped complete with a mounting bracket. The bracket must be securely anchored to the wall using bolts or lag screws. The wall to which the bracket is attached must be sufficiently strong to support the pneumatic cylinder. The bracket should never be fastened to dry wall or similar material. If this type of wall is encountered, studs must be located and the bracket fastened to them. See **Figure 4-4**.

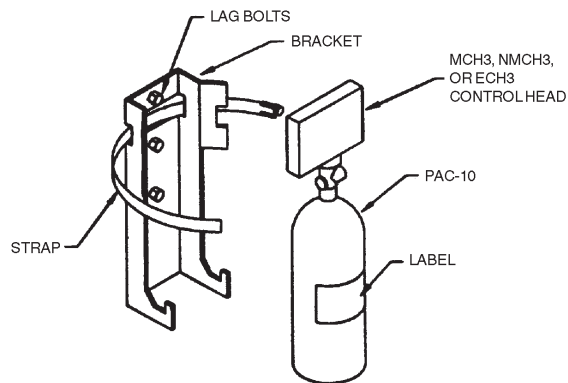

Figure 4-4. Model PAC-10 Pneumatic Cylinder Installation.

002874PC

In order to actuate the agent cylinders from a Model PAC-10 Pneumatic Actuation Cylinder, a 3/4 in. NPT x 1/4 in. NPT bushing must be screwed into the pneumatic cylinder's discharge port. A 1/4 in. NPT x 45° 1/4 in. flare type fitting (conforming to SAE J513c) must then be screwed into this bushing. The male straight connector (Part No. 32338) is used with stainless steel actuation hose. Pneumatic tubing or stainless steel actuation hose is then used to connect the PAC-10 pneumatic cylinder to the valve cap assembly of each agent cylinder valve. See **Figure 4-5**.

NOTE

Pneumatic tubing (copper) used for remote cylinder actuation shall have an outside diameter of 1/4 in. (0.6 cm) with a minimum wall thickness of 1/32 in. (0.08 cm). This is commonly known as refrigeration-type copper tubing. All tubing fittings shall be of the 1/4 in., 45° flare type conforming to SAE J513c.

Compression type fittings are not acceptable.

The Model PAC-10 pneumatic cylinder can actuate a maximum of ten (10) agent cylinders with a maximum of 100 ft (30.5 m) of pneumatic tubing.

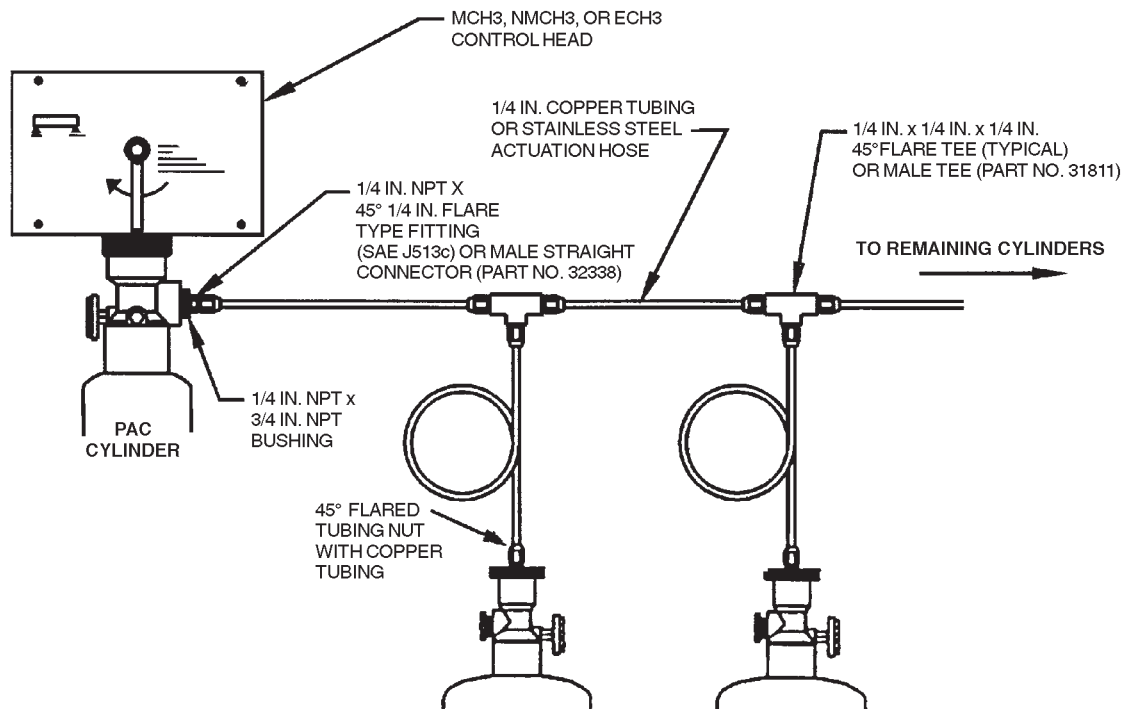

Figure 4-5. Multiple Cylinder Actuation Using Model PAC-10.

004427PC

If the system design requires the use of two control heads for multiple cylinder actuation, a maximum of 25 ft (7.6 m) of tubing is allowed between the two control heads and the PAC-10 cylinder. See **Figure 4-5a**. If a PAC-10 cylinder is not utilized, there is a maximum of 25 ft (7.6 m) of tubing for the two control heads and up to 4 cylinders or a maximum of 18 ft (5.4 m) of tubing for the two control heads and 5 cylinders.

DETECTOR INSTALLATION

Fusible Link Detection

Fusible links are always used in conjunction with the Model MCH3 Mechanical Control Head. After mounting the cylinder and control head, the fusible link line can be installed. The first step to installing the fusible link line is to install the detector bracket(s) over all protected appliances and in each duct. See Chapter III for detector placement guidelines.

Note: Only ML-style Fusible Links can be used.

Connect the fusible link brackets together using 1/2 in. conduit and the conduit connectors supplied in the detector kit (Model FLK-1). A PYRO-CHEM KITCHEN KNIGHT II corner pulley must be used whenever a change in conduit direction is necessary. The conduit is connected to the control head through a knockout in the upper left-side corner.

In general, fusible links centered in the detector brackets are connected in series using 1/16 in. diameter stainless steel cable. The spring plate in the control head maintains tension on this series of fusible links. If the tension is released for any reason (i.e., a fusible link separates), the control head will operate and actuate the system.

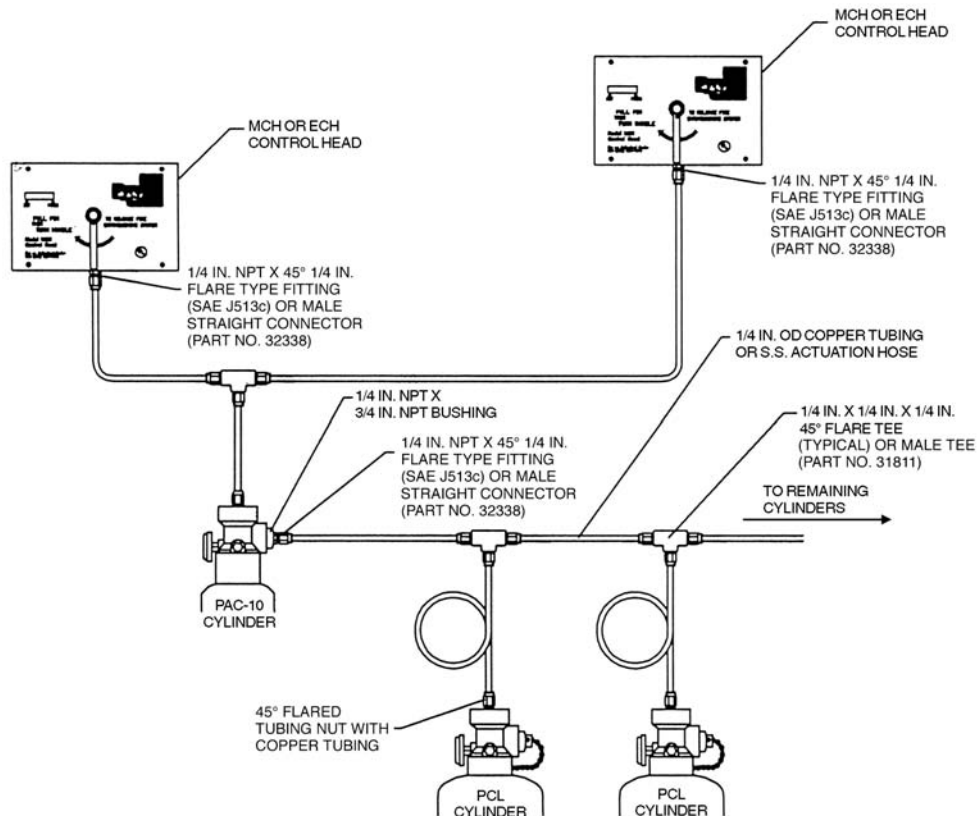

Figure 4-5a. Multiple Cylinder Actuation Using Two Control Heads.

006858

Maximum limitations for the fusible link detection line are as follows:

Fusible links can be installed with or without fusible link hangers (see **Chapter II** for description).

Fusible Link Line Limitations When Used with Model EN-MCU3, MCH3, and NMCH3 Control Heads and CBP-1, SBP-1, and WBP-1 Pulley Elbows

Maximum # of detectors:	20
Maximum length of cable:	150 ft (45.7 m)
Maximum # of pulleys:	40

NOTE

Crimps must always be used in conjunction with two (2) cable lengths. Loops are the accepted method of connecting the cable to mechanical components. **The crimp must never be used on a single cable.** Exception: Single cable crimp allowed in detection and gas valve ratchet wheel using stop sleeve, Part No. 26317 (Packages of 10: Part No. 24919).

Fusible Links Without Hangers

Begin installing links at the terminal bracket. The link is connected to the far side of the terminal bracket using an “S” hook. The “S” hook must be crimped closed after the link is installed. A tight loop is then made in the cable and secured by the crimp provided. This loop is connected to the other side of the terminal link (see **Figure 4-6**) and the cable fed through the conduit to the next bracket. The cable proceeding from the terminal link will be used to connect the series links (see **Figure 4-7**). Series links must be centered in their detector brackets.

After the last link in the series is connected, the cable should be fed through the conduit back to the control head. Thread the cable through the hole in the fusible link ratchet wheel. The line must then be crimped, and the crimp positioned inside the center of the ratchet wheel.

The fusible link line can now be put into a set position by applying tension to the fusible link line. This is accomplished by using a 1/2 in. hex wrench on the fusible link line ratchet wheel. The ratchet wheel will be ratcheted in a clockwise direction until the spring plate makes contact with the top of the control head box. The fusible link line is now in a set position. See **Figure 4-8**.

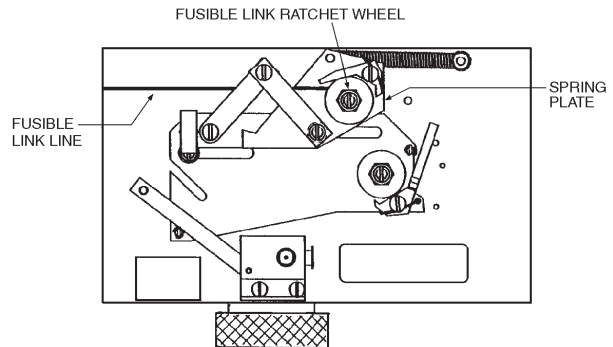

Figure 4-8. Fusible Link Line Termination.

006215PC

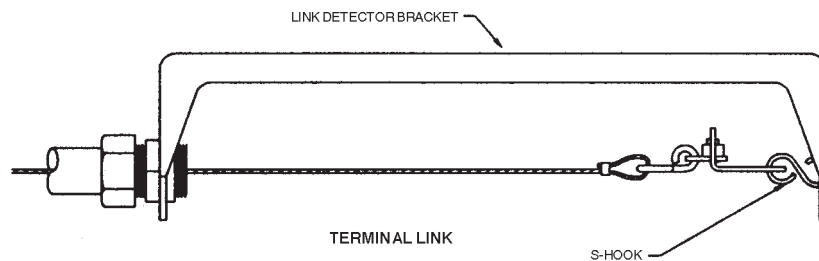

Figure 4-6. Terminal Link Installation.

002849aPC

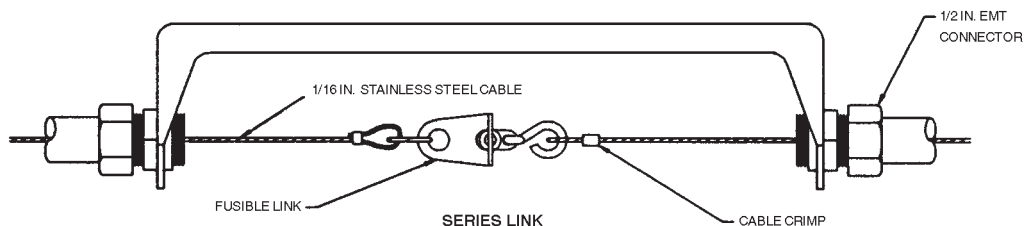

Figure 4-7. Series Link Installation.

002849bPC

Fusible Link Installation Using Model FLH-1 Fusible Link Hangers

Beginning at the control head, feed the stainless steel cable through the conduit and brackets to the terminal bracket in one continuous length. Allow approximately 2.5 in. (6.4 cm) of slack at each bracket for the installation of the Fusible Link Hangers. At the terminal link, a tight loop is made in the cable and secured by the crimp provided. The cable is attached to the far side of the terminal bracket using an “S” hook. The “S” hook must be crimped closed after the cable is installed. See **Figure 4-9**.

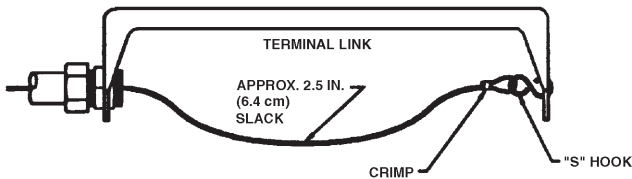

Figure 4-9. Terminal Bracket Connection.
 002877PC

Begin installing the Fusible Link Hangers at the terminal bracket and work toward the control head. Loop the cable through the oval opening in the hanger and hook the fusible link on the loop. See **Figure 4-10**.

Note: Only ML-style Fusible Links can be used.

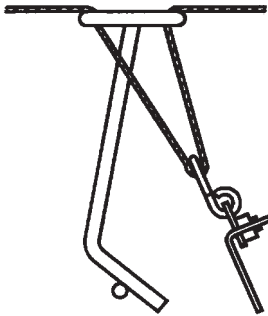

Figure 4-10. Fusible Link Connection.
 002878PC

Hook the bottom of the link onto the bottom leg of the hanger. See **Figure 4-11**.

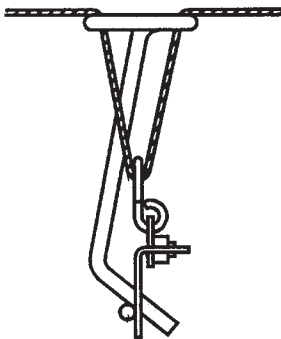

Figure 4-11. Fusible Link/Hanger Connection.
 002879PC

Center the hanger/link in the fusible link bracket by sliding it along the link line. This is easily accomplished before any tension is applied to the link line. Repeat this procedure for all fusible links.

After the last hanger/link in the series is connected, the cable should be fed through the hole in the fusible link ratchet wheel. The line must then be crimped, and the crimp positioned inside the center of the ratchet wheel.

NOTE

Crimps must always be used in conjunction with two (2) cable lengths. Loops are the accepted method of connecting the cable to mechanical components. **The crimp must never be used on a single cable.** Exception: Single cable crimp allowed in detection and gas valve ratchet wheel using stop sleeve, Part No. 26317 (Packages of 10: Part No. 24919).

The fusible link line can now be put into a set position by applying tension to the fusible link line. This is accomplished by using a 1/2 in. hex wrench on the fusible link line ratchet wheel. The ratchet wheel will be ratcheted in a clockwise direction until the spring plate makes contact with the top of the control head box. The fusible link line is now in a set position. See **Figure 4-8**.

Check to ensure that the fusible link hanger(s) remain centered in the bracket after the fusible link line is set. See **Figure 4-12**.

NOTE

If wire rope requires splicing, a splice is to be a minimum of 12 in. (31 cm) from any pulley elbow or conduit adaptor to avoid interference.

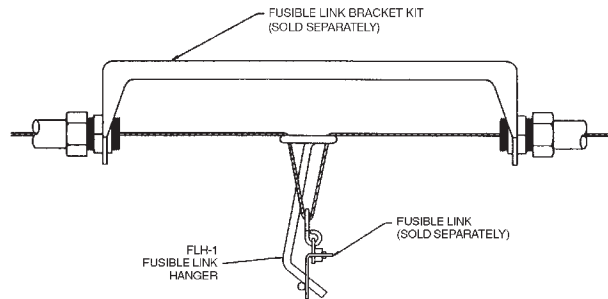

Figure 4-12. Fusible Link/Hanger In Set Position.
 002849bPC

Thermal Detection

Thermal detectors are always used in conjunction with the Model ECH3 Electrical Control Head. After mounting the cylinder and control head, the thermal detector(s) can be installed. Install the thermal detector(s) in the plenum area of the ventilation hood over all protected appliances and in each duct. See **Chapter III** for detector placement guidelines. Follow the instructions included with the detector for proper detector mounting procedures.

SETTING THE CONTROL HEAD

Model MCH3/NMCH3 Mechanical Control Head

Once the fusible link line is set, the control head can be placed in the set position. Set the control head using the proper procedure of ratcheting the detection line to raise the spring plate parallel to the top of the control head box prior to placing the latching arm in the slide plate. The slide plate is moved from right to left, ensuring the bolt extending from the cam arm is in the slot provided in the slide plate. Continue moving the slide plate to the left until the latching arm is in the locked position. Insert the pull pin into the hole in the slide plate above the latching arm. This will lock the control head in the set position, eliminating accidental actuation during the rest of the installation procedure. See **Figure 4-13**.

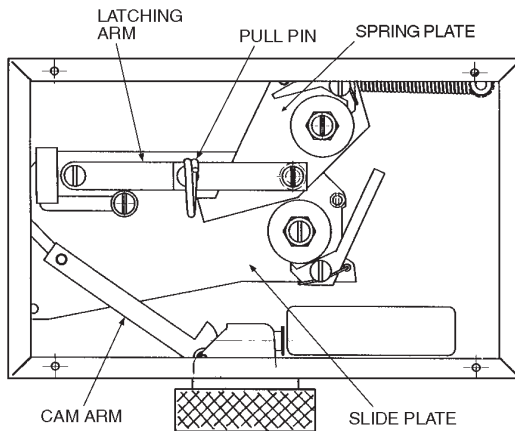

Figure 4-13. Control Head In Set Position.

006219PC

Model ECH3 Electrical Control Head

Once the thermal detectors have been installed, the control head can be placed in the set position. To set the control head, the slide plate is moved from right to left, ensuring the bolt extending from the cam arm is in the slot provided in the slide plate. Continue moving the slide plate to the left until the latching arm is in the locked position. Insert the pull pin into the hole in the slide plate above the latching arm. This will lock the control head in the set position, eliminating accidental actuation during the rest of the installation procedure.

Once the Model ECH3 Electrical Control Head is in the set position, it can be connected to the detection/actuation circuit.

CAUTION

Before working on any electrical wiring, make certain main power has been disconnected. Failure to disconnect main power could cause personal injury or death if contact is made with energized wires. All electrical wiring and connections to be made in accordance with the authority having jurisdiction and all local electrical codes.

NOTE

No electrical connections shall be made inside the control head. All electrical wiring shall exit the control head through the knock-out on the side of the box. All electrical connections must be made in an approved electrical box.

- ▶ Connect one of the black wires on the solenoid in the control head to the red wire of the Model MS-SPDT Electrical (snap-action) Switch. The brown wire from the electrical (snap-action) switch is then connected to one side of the first thermal detector in series. Connect the other side of the first thermal detector in series and the remaining black wire on the solenoid in the control head to the appropriate power source after installing the Model SM-120 Solenoid Monitor.

CAUTION

- ▶ The solenoid must never be wired “hot” (not through the electrical (snap-action) switch). If wired this way, the non-field replaceable solenoid will be damaged and the complete control head will require replacement.

NOTE

- ▶ A Model SM-120 Solenoid Monitor must always be used with an Electrical Control Head to supervise the actuation/detection circuit. Where electrical detection and/or actuation is provided, supervision shall be provided in accordance with NFPA-17A. Alarms and indicators along with a supervised backup power source shall be provided in accordance with NFPA 72, The National Fire Alarm Code. Electrical wiring and equipment shall be installed in accordance with NFPA 70, National Electric Code or the requirements of the authority having jurisdiction.

The Model ECH3-24 Electrical Control Head requires a 24VDC power supply with a minimum 2A rating. The Model ECH3-120 Electrical Control Head requires a 1A, 120VAC power supply.

SOLENOID MONITOR INSTALLATION

Solenoid Monitor Installation in Detection Circuit

- ▶ After installing the thermal detectors and the control head, the Model SM-120 Solenoid Monitor can be installed. The Solenoid Monitor is connected to the wires leading from the last thermal detector. It should be mounted in a location where it can be readily observed.

The Solenoid Monitor is an end-of-line device that supervises the actuation/detection circuit. It is comprised of a push-type switch with a built-in indicator light, a plug-type relay, a relay socket, and a cover plate. The light, when illuminated, indicates that the detection/actuation circuit is in the normal condition. The Solenoid Monitor also provides two sets of dry contacts. The Solenoid Monitor's cover plate is used to mount the Solenoid Monitor in a standard 6 in. x 4 in. x 3 in. (15 x 10 x 8 cm) deep electrical box. See **Figure 4-14**.

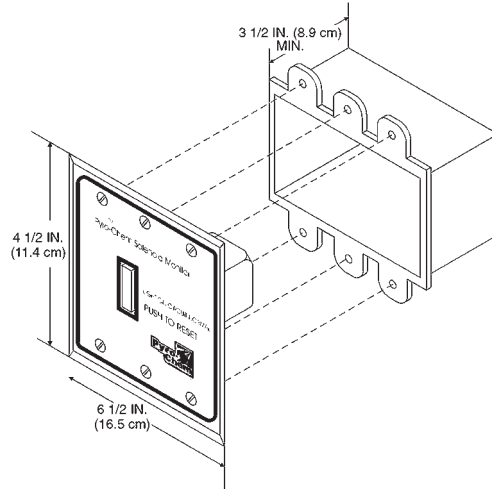

Figure 4-14. Solenoid Monitor Installation.

002881PC

- ▶ All wire for circuits using the Model SM-120 shall be 14 gauge minimum, or as required by local code.

After the Solenoid Monitor has been installed, the detection/actuation circuit can be connected to the appropriate power source and energized. To energize the detector/actuation circuit, depress the switch on the Solenoid Monitor. The light will illuminate to indicate that the circuit is properly installed. If the light fails to illuminate, the wiring must be checked.

Solenoid Monitor When Used As A Reset Relay

- ▶ The Model SM-120 can be used as a reset relay when required. A reset relay is required whenever an electrical gas shut-off valve is used in conjunction with the PYRO-CHEM KITCHEN KNIGHT II Restaurant Fire Suppression System. For typical wiring connections, see **Figure 4-15**.

REMOTE PULL STATION INSTALLATION

NOTE

For flexible conduit/pull station installation instructions, refer to Pages 4-21 through 4-30.

The Model RPS-M Remote Mechanical Pull Station is used for remote mechanical actuation of all system releasing devices. It is to be located near an exit in the path of egress from the hazard area no more than 4 ft. (1.2 m) above the floor.

NOTE

A Model RPS-M Remote Mechanical Pull Station must be used for manual activation of a Model EN-MCU3 or a Model NMCH3 releasing device. If the PYRO-CHEM Releasing Panel is being utilized, then the RPS-E2 Electric Pull Station may be used for manual activation.

The Pull Station can be surface mounted or flush mounted. For flush mounting a RACO #232 4 in. (10 cm) deep electrical box or equivalent must be used (dealer supplied). It is connected to the releasing device using 1/16 in. diameter stainless steel cable. The cable enters the pull station box through the center hole in the bottom, top, either side, or the center back hole. The cable enters the control head through the top-center knockout. The cable must be enclosed in

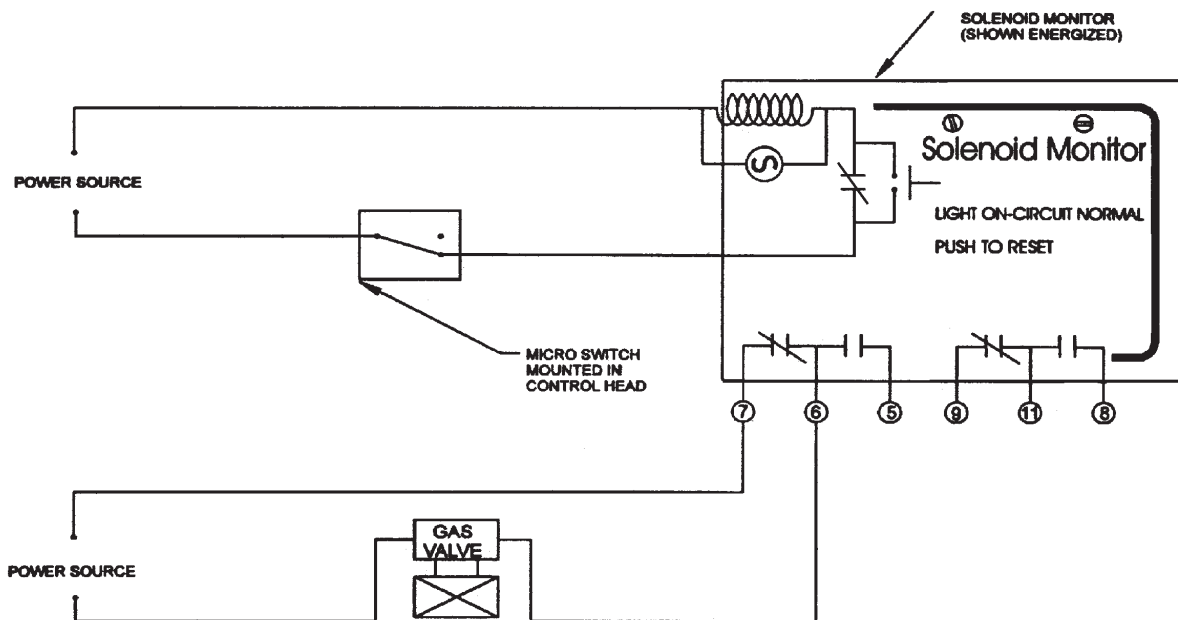

Figure 4-15. Solenoid Monitor Wiring With Electrical Gas Shut-off Valve.

002882PC

1/2 in. EMT conduit with a PYRO-CHEM KITCHEN KNIGHT II corner pulley at each change in conduit direction. Maximum limitations for the Model RPS-M Remote Mechanical Pull Station are as follows:

Model RPS-M Cable Run Limitations When Used with Model ECH3, MCH3, EN-MCU3, and NMCH3 Control Heads and CBP-1, SBP-1, and WBP-1 Pulley Elbows	
Maximum length of cable:	150 ft (45.7 m)
Maximum # of pulleys:	40

After mounting the pull station box and conduit, feed the stainless steel cable from the releasing device, through the conduit, and into the pull station box. Feed the cable through the bushing and through the hole provided in the pull handle. Loop the cable through the pull handle and secure it with the crimp provided (see **Figure 4-16**).

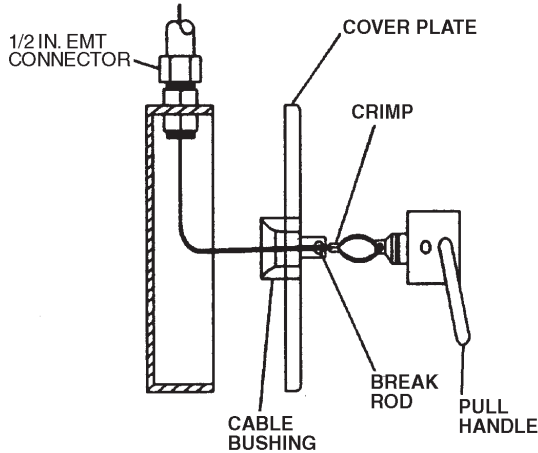

Figure 4-16. Model RPS-M Remote Pull Station Installation.
 002884PC

Cut and thread the cable through the hole in the latching arm of the control head and pull the cable tight. Crimp the cable approximately 6-8 in. (15.2-30.5 cm) below the latching arm. **Note:** NFPA-17A requires the pull length to be no more than 14 in. (36 cm).

NOTE

Crimps must always be used in conjunction with two (2) cable lengths. Loops are the accepted method of connecting the cable to mechanical components. **The crimp must never be used on a single cable.** Exception: Single cable crimp allowed in detection and gas valve ratchet wheel using stop sleeve, Part No. 26317 (Packages of 10: Part No. 24919).

Pull the pull handle until the crimp touches the latching arm. See **Figure 4-17**. Coil the excess cable in the pull box and attach the cover plate with the four screws provided. Insert the pull handle into the cover plate and insert the plastic break rod.

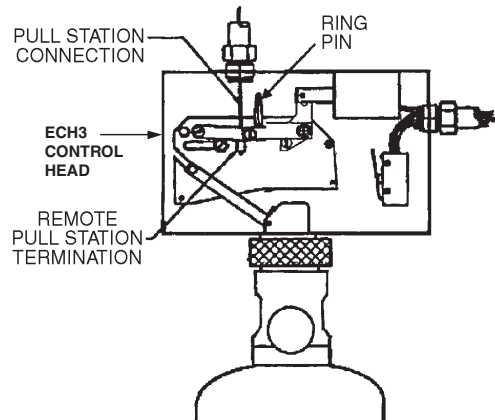
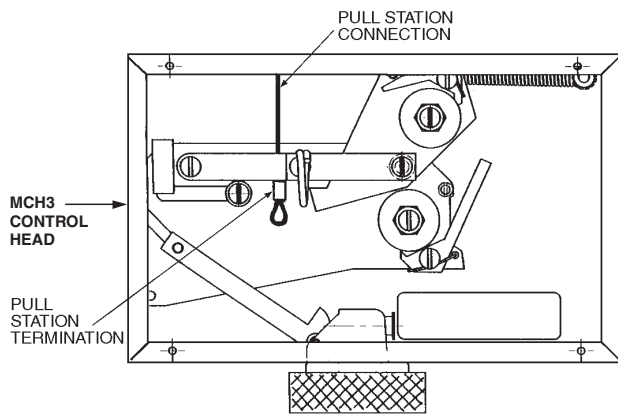

Figure 4-17. Model RPS-M Remote Pull Station.
 006216PC/003647PC

GAS SHUT-OFF VALVE INSTALLATION

▶ All gas valves are designed for indoor installation only. All gas valve installation and testing shall be made in accordance with the authority having jurisdiction.

CAUTION

To reduce the risk of explosion due to leaking gas, make certain that the gas line is turned off before connecting the gas valve.

Mechanical Gas Shut-off Valve Installation

TEMPERATURE LIMITATIONS: Maximum ambient and fluid temperature is 120 °F (49 °C).

POSITIONING: Valve may be mounted in any position.

PIPING:

CAUTION

To prevent damage to valve, **DO NOT OVER-TIGHTEN PIPE CONNECTIONS**. Connect piping to valve in accordance with markings on valve body. Pipe compound should be applied to male pipe threads only. When tightening pipe, do not use valve as a lever. To avoid strain on valve, assure all piping is aligned and supported properly.

STRAINER INSTALLATION: For the protection of the gas valve, install a strainer or suitable filter in the inlet piping, as close to the gas valve as possible. Periodic cleaning of strainers recommended.

PREVENTIVE MAINTENANCE:

1. Keep medium flowing through valve as free from foreign material as possible.
2. Keep valve filter/strainer clean.

IMPROPER OPERATION:

1. **Incorrect Pressure:** Pressure to valve must be within range specified on nameplate.
2. **Leakage:** If leakage is detected, contact an authorized PYRO-CHEM distributor immediately.

The Model MCH3/NMCH3 Control Head is used to operate the mechanical gas shut-off valve. This valve is located in the fuel gas supply line to the cooking appliance(s). The valve body has an arrow which indicates direction of gas flow through the valve. The gas shut-off valve is spring loaded and requires five pounds of force to hold it open. This force is supplied by a 1/16 in. diameter stainless steel cable that is connected to the control head.

After the valve is installed in the gas line, 1/2 in. conduit must be run from the top center knockout of the gas valve box to the lower right-hand knockout in the control head. A PYRO-CHEM KITCHEN KNIGHT II corner pulley is used wherever a change in conduit direction is required.

Gas Valve Cable Run Limitations When Used with Model MCH3, EN-MCU3, and NMCH3 Control Heads and CBP-1, SBP-1, and WBP-1 Pulley Elbows

Maximum length of cable:	100 ft (30.5 m)
Maximum # of pulleys:	30

Remove the gas valve cover and thread the stainless steel cable through the conduit back to the control head. Thread the cable through the hole in the gas valve ratchet wheel. The line must then be crimped, and the crimp positioned inside the center of the ratchet wheel.

NOTE

Crimps must always be used in conjunction with two (2) cable lengths. Loops are the accepted method of connecting the cable to mechanical components. **The crimp must never be used on a single cable.** Exception: Single cable crimp allowed in detection and gas valve ratchet wheel using stop sleeve, Part No. 26317 (Packages of 10: Part No. 24919).

At the gas valve, loop the cable through the valve stem and secure it with the crimp provided (see **Figure 4-18**).

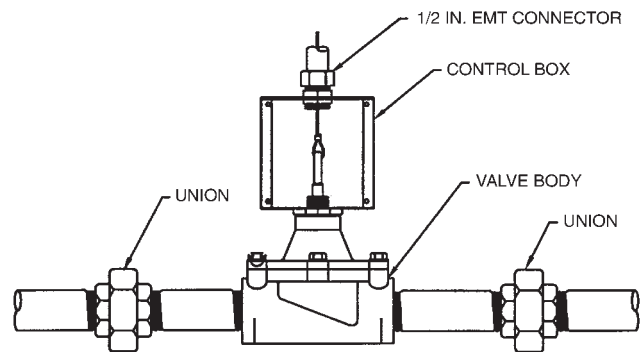

Figure 4-18. Gas Valve Installation.

002886PC

CAUTION

Do not over-tension wire rope going from control head to gas valve at gas valve ratchet wheel. Over-tensioning may cause the valve to not close properly, resulting in the fuel supply not completely shutting off.

The gas valve line can now be put into a set position by applying tension to the gas valve line. This is accomplished by using a 1/2 in. hex wrench on the gas valve ratchet wheel. The ratchet wheel will be ratcheted in a clockwise direction until the gas valve is fully open. See Instruction Sheet, Part No. 550571, included in gas valve shipping assembly, for detailed information. Secure the gas valve cover plate to the gas valve box with the four (4) screws provided. The gas valve line is now in a set position. See **Figure 4-19**.

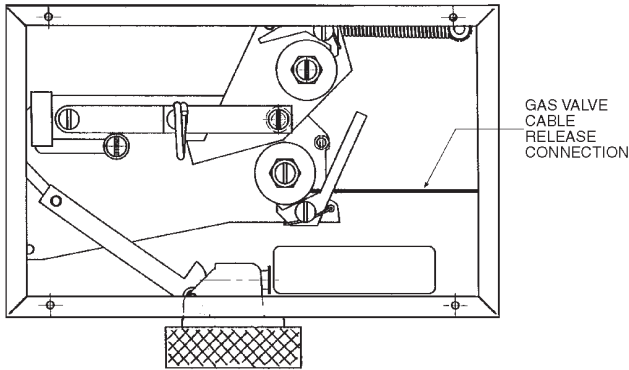

Figure 4-19. Gas Valve Line Termination.

006217PC

Electrical Gas Shut-off Valve Installation

CAUTION

Before working on any electrical wiring, make certain main power has been disconnected. Failure to disconnect main power could cause personal injury or death if contact is made with energized wires. All electrical wiring and connections to be made in accordance with the authority having jurisdiction and all local electrical codes.

The Model MCH3/ECH3/NMCH3 Control Head is used to operate the electrical gas shut-off valve. This valve is located in the fuel gas supply line to the cooking appliance(s). The valve body has an arrow which indicates direction of gas flow through the valve. A reset relay (Solenoid Monitor, Model SM-120) must always be used with an electrical gas shut-off valve. For proper wiring of the electrical gas shut-off valve, see Figure 4-15.

► PULLEY TEE INSTALLATION

- The Pulley Tee is used to connect two (2) mechanical gas valves or two (2) remote mechanical pull stations to a single control head. The cable proceeding from the control head must always enter the branch of the pulley tee. See Figure 4-20.
- A pulley tee that is used to close two (2) gas valves can only be used to close gas valves with similar stem travel. Gas valves from 3/4 in. up to 1 1/2 in. can be used on the same pulley tee. A 2 in. gas valve can be used only with another 2 in. gas valve. Gas valves from 2 1/2 in. up to 3 in. can be used on the same pulley tee. As an example, using a 3/4 in. gas valve with a 3 in. gas valve will not allow the 3 in. valve to fully open.

CAUTION

- The pulley tee must never be used to connect multiple fusible link lines to a single control head.

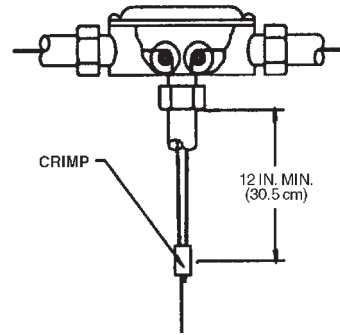

Figure 4-20. Tee Pulley Installation.

002888PC

► ELECTRICAL (SNAP-ACTION) SWITCH INSTALLATION

See NFPA 72, “National Fire Alarm Code,” Initiating Devices section, for the correct method of wiring connection to the fire alarm panel.

- The Model MS-SPDT, MS-DPDT, MS-3PDT, or MS-4PDT Electrical (Snap-Action) Switch is available for use where an electrical output is required. These switches can be field installed in the control head. See Figure 4-21 and Figure 4-22 and refer to Instruction Sheet, Part No. 551159, included with switch shipping assembly, for detailed mounting instructions.

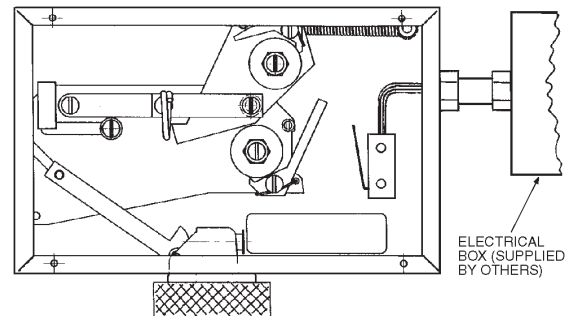

Figure 4-21. Snap-Action Switch Installation in Model MCH3/NMCH3 Control Head.

006218PC

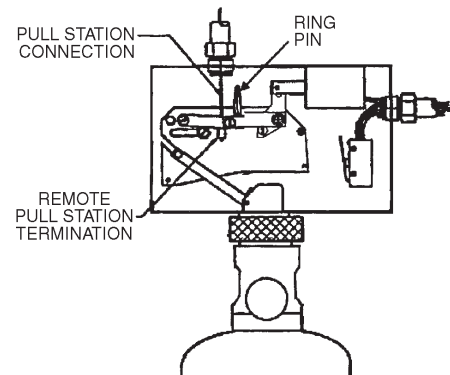

Figure 4-22. Snap-Action Switch Installation in Model ECH3 Control Head.

003647PC

NOTE

The Model ECH3 Control Head is supplied with a Model MS-DPDT Electrical (Snap-Action) Switch. The DPDT switch is a double switch with two sets of normally open (NO) and normally closed (NC) contacts. One set of contacts on the switch must be used in the actuation/detection circuit and cannot be used for electrical output.

NOTE

No electrical connections shall be made inside the control head. All electrical wiring shall exit the control head through the knock-out on the side of the box. All electrical connections must be made in an approved electrical box.

These switches may be used to provide an electrical signal to the main breaker and/or operate electrical accessories provided the rating of the switch is not exceeded. Wiring connections are shown in **Figure 4-23**. The contact ratings for the switch are as follows:

Contact Ratings For Snap-Action Switches

21 amps 1 HP, 125, 250, 277 VAC
 or 2 HP, 250, 277 VAC

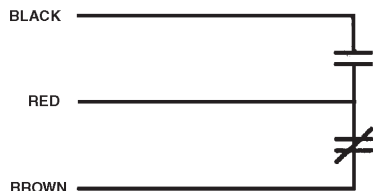

Figure 4-23. Wiring Diagram For Model MS-SPDT Snap-Action Switch.

002903PC

The Alarm Initiating Switch, Part No. 550077, must be used to close a supervised circuit to the building main fire alarm panel when the control head actuates. This will signal the fire alarm panel that there was a system actuation in the kitchen area. This switch can be field installed in the control head. Refer to Instruction Sheet, Part No. 550081, included with the switch shipping assembly, for detailed mounting instructions. Wiring connections are shown in **Figure 4-24**. The switch is rated at 50mA, 28VDC.

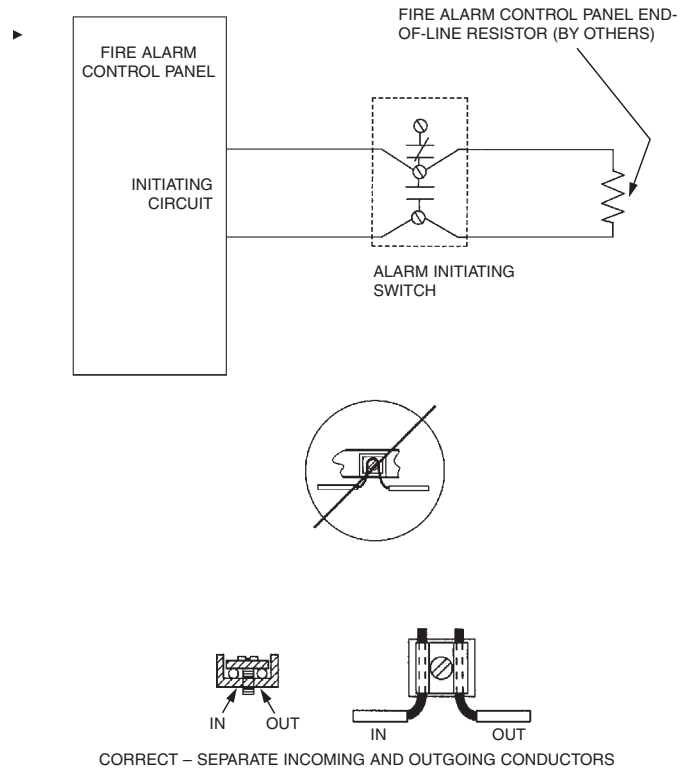

Figure 4-24. Wiring Diagram for Alarm Initiating Switch.

004891/004905

PIPE AND NOZZLE INSTALLATION

All pipe ends shall be thoroughly reamed after cutting and all oil and foreign matter removed from the pipe. The following procedures must be followed:

1. Use Schedule 40 black iron, chrome-plated, or stainless steel pipe and fittings. Do not use hot-dipped galvanized iron pipe or fittings in the agent distribution piping.
2. Before assembling the pipe and fittings, make certain all ends are carefully reamed and blown clear of chips and scale. Inside of pipe and fittings must be free of oil and dirt.
3. The distribution piping and fitting connections, located in the hood or the protected area, must be sealed with pipe tape. When applying pipe tape, start at the second male thread and wrap the tape (two turns maximum) clockwise around the threads, away from the pipe opening.
4. Do not over-tighten, but be sure the pipe is snug. Do not back-off sections of pipe to make them fit better. If the pipe was cut too short, re-cut another pipe to the proper length.

CAUTION

Do not apply Teflon tape to cover or overlap the pipe opening, as the pipe and nozzles could become blocked and prevent the proper flow of agent.
 Do not use thread sealant or pipe joint compound.

All piping shall be securely fastened by means of pipe hangers and/or pipe straps. The spacing requirements for hangers/straps depend on the pipe size being utilized. Refer to the **Spacing Guidelines Chart** below.

Pipe Hanger Spacing Guidelines

Distribution Pipe Size	Maximum Spacing Distance	
	Hanger to Hanger	
in.	ft	(m)
1/4	4	(1.2)
3/8	5	(1.5)
1/2	6	(1.8)
3/4	8	(2.4)

A union should be installed in the discharge piping, as close to the cylinder valve as possible, to permit disconnection and removal for inspection and service. Dry air or nitrogen should be blown through the discharge piping to remove chips and other debris prior to installation of nozzles.

Nozzles shall be installed in accordance with the limitations described in **Chapter III** of this manual. Blow-off caps are provided for each nozzle. These will prevent dirt and grease from clogging the nozzle.

**INSTALLATION INSTRUCTIONS FOR
CASTERED/MOVEABLE EQUIPMENT
USING PYRO-CHEM AGENT
DISTRIBUTION HOSE**

WARNING

The following instructions must be followed in their entirety. Failure to do so may result in the KITCHEN KNIGHT® II Fire Suppression System not functioning properly due to incorrect installation.

Critical Installation Requirements

1. Design and installation must be performed by qualified personnel.
2. The Agent Distribution Hose shall not be concealed within or run through any wall, floor, or partition, and shall not have any direct exposure to excessive heat or radiant flame from the cooking appliances.
3. Strong cleaning solutions or chemical substances must not come in contact with the Agent Distribution Hose. These may include acids, solvents, fluxes with zinc chloride, or other chlorinated chemicals. In case of contact, rinse down the Agent Distribution Hose with water and dry thoroughly.
4. Contact with foreign objects, sharp edges, wiring, or substances must be avoided.

5. Bending and flexing of Agent Distribution Hose on moveable appliances (i.e. those factory equipped with casters) should be limited to pulling and pushing the appliances in or out for cleaning or maintenance. The hose shall never be installed or bent tighter than a 3 in. (7.6 cm) radius (6 in. (15.2 cm) diameter) loop.
6. The Agent Distribution Hose must not be kinked, twisted, or have sharp bends when installed or when equipment is pulled away from the wall.
7. Make sure that all fittings are tightened properly.
8. Adequate means must be provided to limit the movement of castered appliances. A 36 in. (91.4 cm) long Restraining Cable supplied with the agent distribution hose is required to be used for all castered appliances using the Agent Distribution Hose. (Refer to Restraining Cable Installation Instructions.)
9. The Restraining Cable requires periodic maintenance to ensure proper operation.
10. The Restraining Cable must be attached to the wall and appliance anytime the distribution hose is connected to the appliance.
11. Do not over-extend the Agent Distribution Hose when moving equipment (for cleaning, maintenance, etc.).

**AGENT DISTRIBUTION HOSE
INSTALLATION INSTRUCTIONS**

Before proceeding, **CAREFULLY** read all instructions, including all **CRITICAL INSTALLATION REQUIREMENTS**.

General Requirements

1. The Agent Distribution Hose, Part No. 434462 (which is part of Discharge Hose and Tether Kit, Part No. 435982), is 1/2 in. (12.7 mm) diameter x 60 in. (152.4 cm) long and is provided with two (2) male NPT swivels for ease of installation.
2. Maximum of six (6) Agent Distribution Hoses can be used in each agent distribution piping network on PCL-460 and PCL-600 systems and a maximum of three (3) Agent Distribution Hoses can be used in each agent distribution piping network on PCL-160 and PCL-300 systems.
3. Agent Distribution Hose can only be used for castered appliances or appliances setting on castered supports.

Installation Requirements

1. Agent Distribution Hose must be connected to 3/8 in. NPT black iron, chrome-plated, or stainless steel fittings. The connection from hose to fitting requires a 1/2 in. x 3/8 in. reducing coupling. All Agent Distribution Hose connections must be sealed with pipe tape. When applying pipe tape, start at the second male thread on the swivel ends of the hose. Wrap the tape (two turns maximum) clockwise around the threads, away from the hose end fitting opening.
2. All connections of distribution piping to Agent Distribution Hose for castered appliances, with distribution nozzles installed/affixed to the appliance, must be located behind the cooking equipment in an area protected from obstructions and possible wear or damage.
3. 3/8 in. schedule 40 pipe will need to be run from the hose connection to the distribution nozzle(s) installed/affixed to the appliance. Pipe must be installed and adequately secured at a height at or below the cooking surface of the appliance. See **Figure 4-30**.
4. All existing distribution pipe and fitting limitations must be observed and followed. Each flex distribution hose used is to be considered as 300 ml when calculating the milliliters per system.
5. All hose-to-pipe connection fittings are to be oriented in a vertical down position.
6. The hose connections must be positioned below an elevation where the hose could be exposed to the radiant or convected heat generated by normal cooking operations (such as the horizontal plane of appliance's cooking surface), or to heat from appliance exhaust. As a minimum height, the hose connection shall be no lower than 30 in. (76.2 cm) from the floor. The distribution piping shall be supported and secured per local plumbing practices.
7. Hose ends are to be offset 6 to 8 in. (15.2 to 20.3 cm) center to center of fittings (see **Figure 1**) to maximize hose life expectancy and facilitate appliance movement. With the appliance in its normal operating position, check the hose bend to make certain the bend is not less than a 3 in. (7.6 cm) bend radius (6 in. (15.2 cm) diameter).

OVERHEAD VIEW

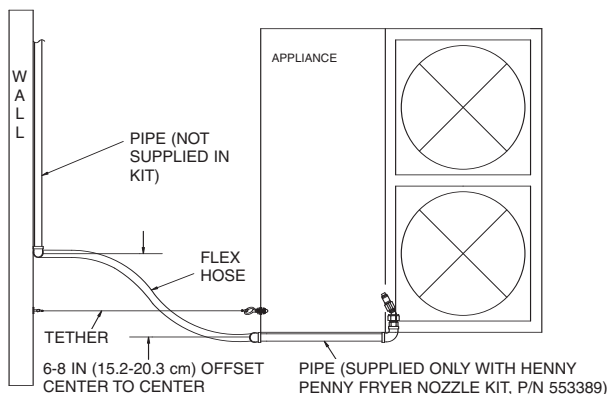

Figure 4-25.

007828

Restraining Cable Installation

Important: A Restraining Cable shall always be permanently attached to the appliance and wall directly behind the appliance when the Agent Distribution Hose is installed. Removal of this cable shall only occur when the Agent Distribution Hose is not installed to the appliance.

See **Figure 4-26** for mounting the Restraining Cable to the wall. See **Figure 4-27** for mounting the Restraining Cable to the back of an appliance.

RESTRAINING CABLE – WALL-MOUNTED OPTION

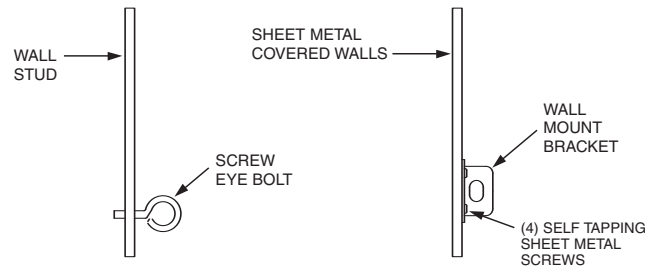

Figure 4-26.

008088

RESTRAINING CABLE – APPLIANCE-MOUNTED OPTION

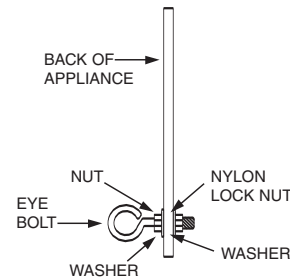

Figure 4-27.

008089

RESTRAINING CABLE – HENNY PENNY-MOUNTED OPTION

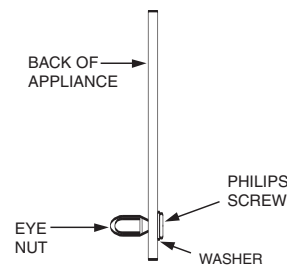

Figure 4-28.

008090

1. The Restraining Cable must be connected from the appliance to the wall or some other structurally sound object capable of restraining the castered appliance from being able to be pulled or pushed out to a point that will result in strain or stress to the Agent Distribution Hose.
2. The Restraining Cable should be installed in line with the Agent Distribution Hose.
3. For sheet metal covered walls, the Restraining Cable Assembly includes four (4) 3/4 in. x #8 self tapping sheet metal screws, and a Restraining Cable Bracket. Securely attach the Restraining Cable Bracket to the sheet metal covered wall using the 3/4 in. x #8 self tapping metal screws provided.
4. For mounting to wall studs, the Restraining Cable Assembly includes one (1) screw eye lag bolt, 5/16 in. 2.5 in. (6.4 cm) long.
5. Locate a structural area (frame) on the rear side of the equipment that is in line with the wall attachment. **Note:** It may be necessary to contact the appliance manufacturer for a suitable location. Drill a 5/16 in. (8 mm) diameter hole. Use caution when drilling hole, so that internal components are not damaged.
6. The Restraining Cable Assembly also includes a 5/16 in. threaded eye-bolt, 5/16 in. hex head nut, 5/16 in. nylon lock nut, and two (2) 5/16 in. flat washers. Thread the included hex nut onto the eye-bolt. Slide one washer onto the eye-bolt threads next to the nut. Then, slide the eye-bolt through the drilled hole and place a washer and nylon locknut onto the eye-bolt on the inside frame of the equipment. Tighten securely.
7. Attach one of the snap hooks (included in the Restraining Cable package) on the end of the Restraining Cable to the wall bracket and the other snap hook to the eye-bolt. See **Figure 4-29**. After snap-hooking the assembly, seal the Restraining Cable Loops to the wall bracketry and appliance connection hardware with Lead Wire Seal, Part No. 197.

Note: For the Henry Penny Pressure Fryers that utilize the PYRO-CHEM Henry Penny Fryer Nozzle Kit, Part No. 553389, the 5/16 in. philips screw supplied in the Henry Penny Fryer Nozzle Kit, the 5/16 in. eye nut, and 5/16 in. washer included in the Restraining Cable Assembly Kit, must be used. See **Figure 4-28**.

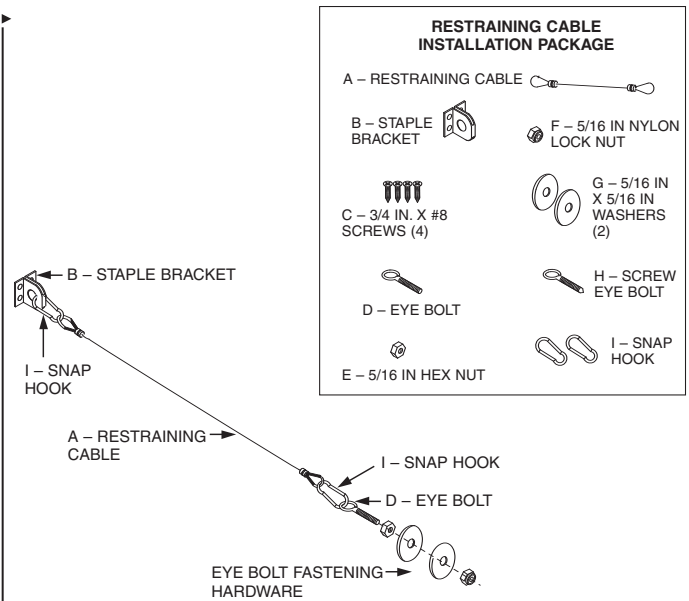

Figure 4-29.
 007829

Final Installation Guidelines and Checkout Procedures

After the Agent Distribution Hose and the Restraining Cable is properly installed, carefully push the appliance back to its normal operating position. Check that the hose does not have sharp bends, and is not kinked, twisted, or caught on anything behind the appliance.

1. Verify the Restraining Cable limits the travel of the appliance and prevents the application of any pull force or bending stress on the Agent Distribution Hose or hose-to-pipe connections.
2. Make certain there are no sharp bends and kinks in the hose when pulling out the cooking equipment.
3. The Agent Distribution Hose should always be in a vertical natural loop, never having any bends greater than a 3 in. (7.6 cm) radius (6 in. (15.2 cm) diameter), hose twists, or sharp bends. See **Figure 4-30**. If any of these conditions exist, the hose and/or hose connections will require installation modifications.

SIDE VIEW

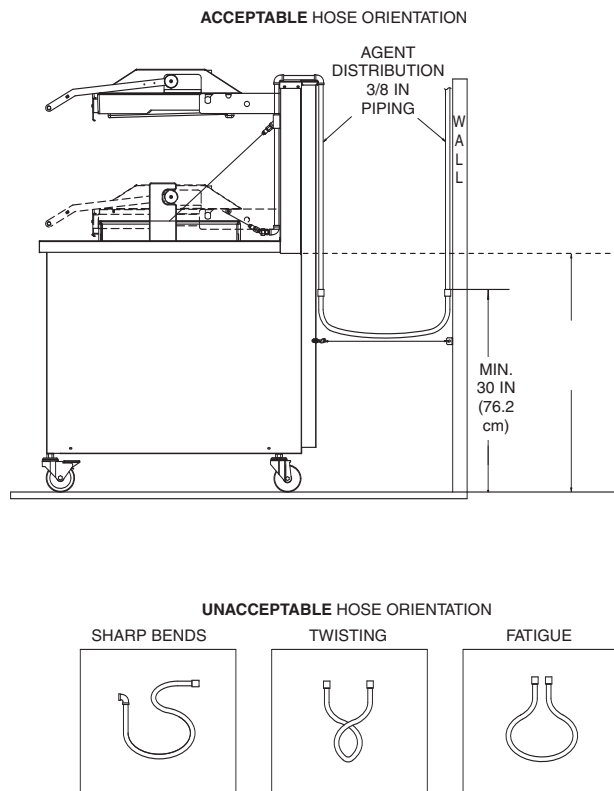

Figure 4-30.

007830

4. Return the appliance to its normal operating position in accordance with NFPA 96. Means shall be provided to verify that the appliance returns to its original designed positioning. Failure to do so may result in undue stress and fatigue of the hose and hose connections.

Agent Distribution Hose/Restraining Cable Six Month Maintenance

1. Carefully pull or push out the appliance and verify that the Restraining Cable limits the travel of the appliance and prevents the application of any pull force or bending stress on the Agent Distribution Hose or hose-to-pipe connections.
2. Check the Restraining Cable to verify it is not frayed and is securely fastened to the appliance and the wall or restraining location.
3. Check the hose and hose fittings and verify that the hose remains in a vertical natural loop with no noticeable fatigue at hose end couplings, no hose twists, no hose kinking or sharp bends. See **Figure 4-30**.
4. Check the outer hose covering for signs of damage, checking, tears, or wear. If any of these signs are observed, replace the hose.
5. Return the appliance to its normal operating position. Again, check the hose and hose fittings to verify that the hose does not have sharp bends, and is not kinked, twisted, or caught on anything behind the appliance. If any of these conditions exist, the hose and/or hose connections will require installation modifications.
6. With the appliance in its normal operating position, check the hose bend to make certain the bend is not less than a 3 in. (7.6 cm) bend radius (6 in. (15.2 cm) diameter). If less, replace hose.
7. Verify that the appliance is returned to its original desired location. Failure to do so may result in undue stress and fatigue of the hose and hose connections.
8. 12-Year Maintenance – Hydrostatic test required at 220 psi (15.2 bar) for hose assembly.

► **Note:** Agent Distribution Hose patent pending.

(Page Intentionally Left Blank)

SYSTEM CHECKOUT AFTER INSTALLATION

1. Model MCH3/NMCH3 Mechanical Control Head

Before putting the system into service, all components must be checked for proper operation. During this checkout, assure that the carbon dioxide pilot cartridge is not installed in the control head actuator. Remove the pull pin from the hole in the slide plate.

To check satisfactory operation of the control head, cut the terminal link or the “S” hook holding the link. This will relieve all tension on the fusible link line and operate the control head. The slide plate will move fully to the right. The gas valve cable will be released, causing the gas valve to close. Any auxiliary equipment connected to the dry contacts of the solenoid monitor and/or the Electrical (Snap-Action) Switch in the control head will operate.

If any of these events fail to occur, the problem must be investigated and repaired.

Repair the terminal link and put the fusible link line back into the set position. This is accomplished by using a 1/2 in. hex wrench on the fusible link line ratchet wheel. The ratchet wheel will be ratcheted in a clockwise direction until the spring plate makes contact with the top of the control head box.

Once the fusible link line is set (note: Refer to page 4-4 through 4-6 for fusible link installation details), the control head can be placed in the set position. To set the control head, the slide plate is moved from right to left, ensuring the bolt extending from the cam arm is in the slot provided in the slide plate. Continue moving the slide plate to the left until the latching arm is in the locked position.

Once the control head is set, pull the pull handle on the remote pull station to assure that the control head operates. If the control head operates normally, the control head can be reset as described above. Insert the pull pin into the hole in the slide plate above the latching arm. Replace the pull station handle, pull pin, and nylon tie.

Assure that the gas valve is fully open by ratcheting the gas valve ratchet wheel.

CAUTION

Before screwing the 16 gram carbon dioxide pilot cartridge into the actuator, ensure that the actuator has an O-ring washer installed.

Using a felt-tipped marker, write the date of installation on the carbon dioxide pilot cartridge. Screw the cartridge into the control head actuator until hand-tight. Never use a wrench to tighten the cartridge into the actuator.

Remove the pull pin from the hole in the slide plate and install the control head cover. Insert the pull pin through the local manual control handle and into the bushing. Secure the pull pin with the nylon tie provided.

2. Model ECH3-24/120 Electrical Control Head.

Before putting the system into service, all components must be checked for proper operation. During this checkout, assure that the CO₂ pilot cartridge is not installed in the control head actuator. Remove the pull pin from the hole in the slide plate.

CAUTION

Make certain to remove the CO₂ cartridge. Failure to do so during testing will result in system actuation.

Testing Thermal Detectors

1. Remove the electric control head cover.
2. Test each detector individually and reset control panel and recock release mechanism after each test. (Refer to proper AUTOPULSE control panel reset instructions).
3. Using a heat gun positioned approximately 12 in. from the detector, apply heat to the detector for about one minute. Overheating will cause damage to the detector. Applying heat to the detector will cause the control head to operate or will cause the AUTOPULSE control panel to go into an alarm condition, and activate the control head. When the control head operates, the following will take place: a) The slide plate will move fully to the right; b) The indicator light on the solenoid monitor will go out; and c) Any auxiliary equipment connected to the dry contacts of the solenoid monitor and/or the snap-action switch in the control head will operate. If any of these events fail to occur, the problem must be investigated and repaired.
4. After all the thermal detectors have cooled, the AUTOPULSE control panel can be reset (refer to proper AUTOPULSE control panel reset instructions) and the control head can be placed in the set position. To set the control head, the slide plate must be moved from right to left, ensuring the bolt extending from the cam arm is in the slot provided in the slide plate. Continue moving the slide plate to the left until the latching arm is in the locked position.

Testing Remote Pull Station

1. Once the control head is set, pull the pull handle on the remote pull station to assure that the control head operates. If the control head operates normally, the control head can be reset as described in Step 4 above.
2. Insert the pull pin into the hole in the slide plate above the latching arm.
3. Replace the pull station handle, pull pin, and break rod.

Completing System Checkout

1. Make certain the AUTOPULSE control panel is reset and the control head is re-cocked and set. If the Model SM-120 Solenoid Monitor is used instead of an AUTOPULSE control panel, energize the actuation/detection circuit by depressing the push button on the solenoid monitor.
2. Using a felt-tipped marker, write the date of installation on the CO₂ pilot cartridge. Ensure that the actuator has an O-ring installed, and screw the cartridge into the control head actuator until hand tight. Continue installation of cartridge by turning an additional 1/4 turn using a wrench or pliers. **Use caution not to damage cartridge.**

Note 1: 4 to 5 threads should be showing when the cartridge is engaged properly. It is important that no more than 5 threads be showing.

Note 2: The cartridge and o-ring shall be replaced annually.

CAUTION

Do not over-tighten cartridge. Over-tightening can result in premature puncturing of the cartridge seal.

3. Remove the pull pin from the hole in the slide plate and install the control head cover. Insert the pull pin through the local manual control handle and into the bushing. Secure the pull pin with the tie provided.

NOTE

Refer to NFPA-17A for additional inspection requirements.

ENCLOSURE INSTALLATION INSTRUCTIONS

MODEL EN-MCU3 (P/N 551208) AND MODEL EN-S (P/N 550966)

Enclosure Mounting

The Model EN-MCU3 and/or EN-S Enclosure must be securely anchored to the wall using bolts or lag screws. The wall to which the enclosure is attached must be sufficiently strong. The enclosure should never be fastened to dry wall or similar material. If this type of wall is encountered, studs must be located and the enclosure fastened to them.

Three (3) center mounting holes allow either enclosure to be mounted on a single stud. Four (4) corner mounting holes are also available. See **Figure 4-31**.

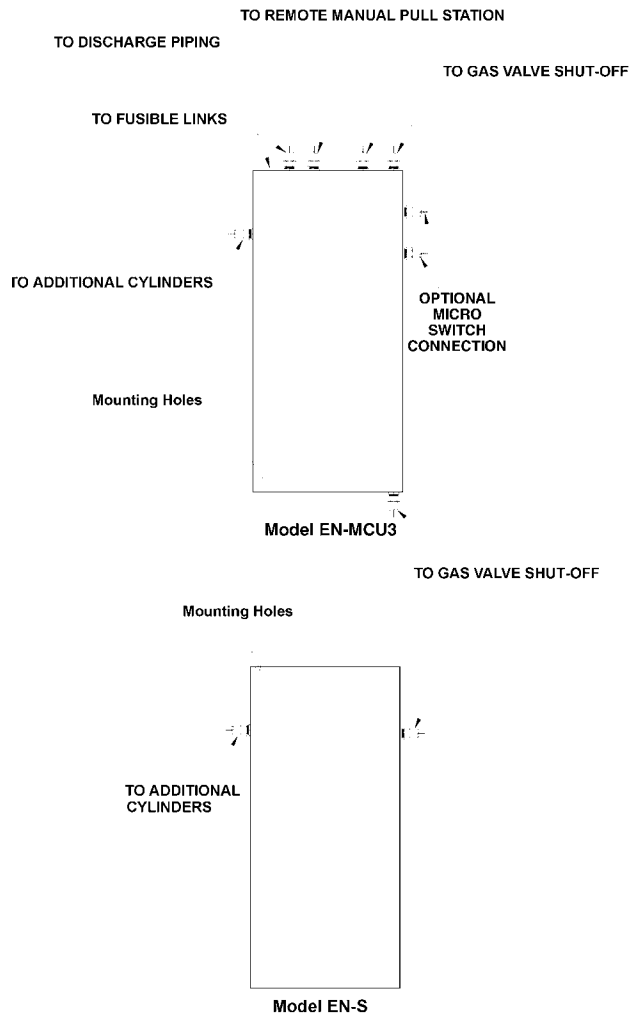

► **Figure 4-31. Models EN-MCU3 and EN-S Enclosures.**

002946PC

Fusible Link Detector Installation

The Model EN-MCU3 Enclosure can support a fusible link detection system. The Model EN-S Enclosure cannot support a fusible link detection system and must be used in conjunction with the Model EN-MCU3 Enclosure or a Model MCH3/ECH3/NMCH3 Control Head.

After mounting the enclosure, the fusible link line can be installed. The first step to installing the fusible link line is to install the detector brackets. These brackets must be installed in the plenum area of the ventilation hood over all protected appliances and in each duct. See **Chapter III** for detector placement guidelines. Connect the fusible link brackets together using 1/2 in. EMT conduit and the conduit connectors supplied in the detector kit (Model FLK-1/1A). PYRO-CHEM KITCHEN KNIGHT II corner pulleys must be used whenever a change in conduit direction is necessary. The conduit is connected to the enclosure through a top knockout.

See Fusible Link Detector Installation Section of this chapter (pages 4-4 – 4-7) for fusible link installation guidelines. Before attaching the stainless steel cable to the fusible link line ratchet wheel, it must be run below the fusible link line pulley in the enclosure. See **Figure 4-32**.

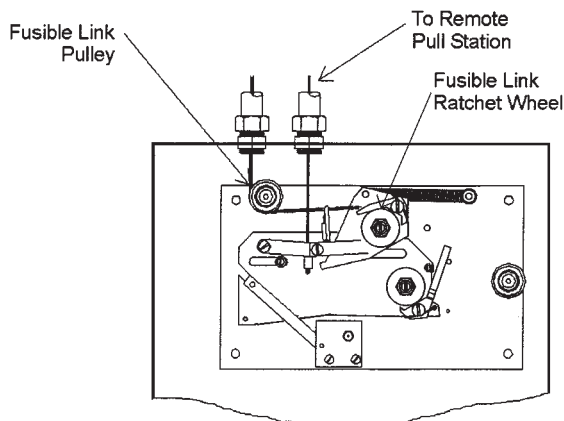

► **Figure 4-32. Model EN-MCU3 Fusible Link Line and Remote Pull Station Termination.**

002947PC

Setting the Model EN-MCU3

After the last link in the series is connected, the cable should be fed through the conduit back to the Model EN-MCU3. It must be fed under the fusible link line pulley and through the hole in the fusible link ratchet wheel. The line must then be crimped, and the crimp positioned inside the ratchet wheel.

NOTE

Crimps must always be used in conjunction with two (2) cable lengths. Loops are the accepted method of connecting the cable to mechanical components. **The crimp must never be used on a single cable.** Exception: Single cable crimp allowed in detection and gas valve ratchet wheel using stop sleeve, Part No. 26317 (Packages of 10: Part No. 24919).

The fusible link line can now be put into a set position by tensioning the fusible link line. This is accomplished by using a 1/2 in. hex wrench on the fusible link line ratchet wheel. The ratchet wheel will be ratcheted in a clockwise direction until the spring plate is parallel to the top of the enclosure. The fusible link line is now in a set position.

Once the fusible link line is set, the Model EN-MCU3 Enclosure can be placed in the set position. To set the Model EN-MCU3, the slide plate is moved from right to left, ensuring the bolt extending from the cam arm is in the slot provided in the slide plate. Continue moving the slide plate to the left until the latching arm is in the locked position. Insert the pull pin into the hole in the slide plate above the latching arm. This will lock the control mechanism in the set position, eliminating accidental actuation during the rest of the installation procedure. See

► **Figure 4-32.**

Remote Pull Station Installation

The Model RPS-M Remote Mechanical Pull Station is used for remote manual actuation of the Model EN-MCU3. It is to be located near an exit in the path of egress from the hazard. Height and location of pull station should be determined in accordance with the Authority Having Jurisdiction.

The Pull Station is connected to the Model EN-MCU3 using 1/16 in. diameter stainless steel cable. The cable enters the Model EN-MCU3 through a knockout in the top of the enclosure. See **Figure 4-32**.

See Remote Pull Station Installation Section of this chapter for remote pull station installation guidelines.

Gas Shut-off Valve Installation

The Model EN-MCU3 can be used to operate a mechanical gas shut-off valve. This valve is located in the fuel gas supply line to the cooking appliance(s). The valve body has an arrow which indicates direction of gas flow through the valve. The gas shut-off valve is spring loaded and requires five pounds of force to hold it open. This force is supplied by a 1/16 in. diameter stainless steel cable that is connected to the Model EN-MCU3.

See “Gas Shut-off Valve Installation” (page 4-11) section of this chapter for gas valve shut-off installation guidelines.

After the valve is installed in the gas line, 1/2 in. conduit must be run from the top center knockout of the gas valve box to the top or bottom knockout in the enclosure. See **Figure 4-31**. A PYRO-CHEM KITCHEN KNIGHT II corner pulley is used whenever a change in conduit direction is required.

Remove the gas valve cover and thread the stainless steel cable through the conduit back to the Model EN-MCU3. If the cable enters the enclosure through the bottom knockout, the cable must be run over the gas valve line pulley (see **Figure 4-33**). If the cable enters the enclosure through the top knockout, the cable must be run under the gas valve line pulley (see **Figure 4-34**). Thread the cable through the hole in the gas valve ratchet wheel. The line must then be crimped, and the crimp positioned inside the center of the ratchet wheel.

CAUTION

The gas valve cable must always utilize the gas valve pulley and exit the **top** or **bottom** of the enclosure. **The gas valve cable cannot exit the side of the enclosure.**

At the gas valve, loop the cable through the valve stem and secure it with the crimp provided (see **Figure 4-18**, page 4-11).

The gas valve line can now be put into a set position by applying tension to the gas valve line. This is accomplished by using a 1/2 in. hex wrench on the gas valve ratchet wheel. The ratchet wheel will be ratcheted in a clockwise direction until the gas valve is fully open. Secure the gas valve cover plate to the gas valve box with the four (4) screws provided. The gas valve line is now in a set position. See **Figure 4-33** and/or **Figure 4-34**.

CAUTION

Do not over-tension wire rope going from control head to gas valve at gas valve ratchet wheel. Over-tensioning may cause the valve to not close properly, resulting in the fuel supply not completely shutting off.

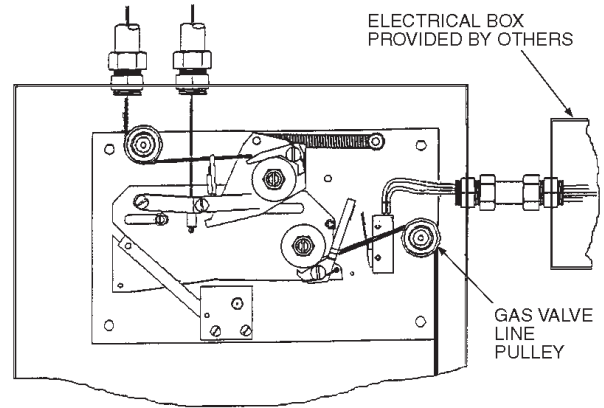

► **Figure 4-33. Gas Valve / Snap-Action Switch Installation.**

002948PC

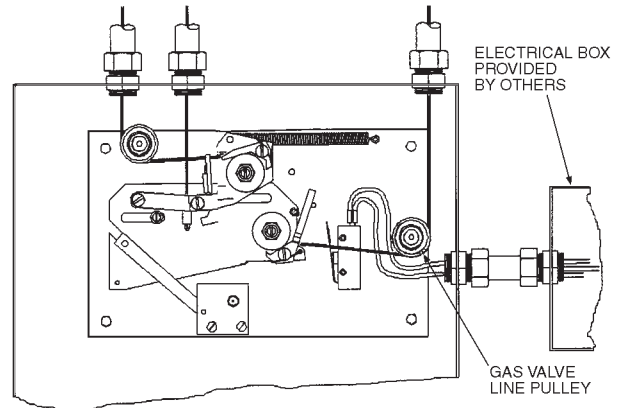

► **Figure 4-34. Gas Valve / Snap-Action Switch Installation.**

002949PC

► Electrical (Snap-Action) Switch Installation

See NFPA 72, “National Fire Alarm Code,” Initiating Devices section, for the correct method of wiring connection to the fire alarm panel.

The Model MS-SPDT, MS-DPDT, MS-3PDT, or MS-4PDT Electrical (Snap-Action) Switch is available for use where an electrical output is required. These switches can be field installed in the Model EN-MCU3. See **Figure 4-33** and/or **Figure 4-34**.

These switches may be used to provide an electrical signal to the main breaker and/or operate electrical accessories provided the rating of the switch is not exceeded. Wiring connections for the Model MS-SPDT are shown in **Figure 4-23** (page 4-12). The contact ratings for both switches are as follows:

**Contact Ratings For Snap-Action Switches: 21 amps
1 HP, 125, 250, 277 VAC or 2 HP, 250, 277 VAC**

- ▶ Three (3) knockouts are provided for Electrical (Snap-Action) Switch wiring. The upper right-side knockout must be used when the gas valve line exits the bottom of the enclosure (see **Figure 4-33**). The lower right-side knockout must be used when the gas valve line exits the top of the enclosure (see **Figure 4-34**). An additional knockout located on the top of the enclosure is also provided (see **Figure 4-31**) and may be used in either situation.

NOTE

No electrical connections shall be made inside the control head. All electrical wiring shall exit the control head through the knock-out on the side of the box. All electrical connections must be made in an approved electrical box.

Cylinder Installation

1. Single Cylinder Installation – PCL-300/460

The Model EN-MCU3 can be used for single cylinder installations. It can support either the Model PCL-300 or PCL-460 cylinder assemblies. The cylinder must be placed in the enclosure with the discharge port to the left. **No additional mounting bracket is required when the Model EN-MCU3 is used.**

In order to actuate the agent cylinder from the Model EN-MCU3s control mechanism, pneumatic tubing must be used to connect the actuator to the valve cap assembly of the agent cylinder valve. A 1/8 in. NPT x 1/4 in., 45° flare type elbow is included and must be installed in the actuator of the Model EN-MCU3 Enclosure. See **Figure 4-35**.

NOTE

Pneumatic tubing (copper) used for cylinder actuation shall have an outside diameter of 1/4 in. (0.6 cm) with a minimum wall thickness of 1/32 in. (0.08 cm). This is commonly known as refrigeration-type copper tubing. All tubing fittings shall be of the 1/4 in., 45° flare type conforming to SAE J513c. **Compression type fittings are not acceptable.**

2. Multiple Cylinder Installation – PCL-300/460

The Model EN-S can be used in conjunction with the Model EN-MCU3 Enclosure or Model MCH3/ECH3 Control Head for multiple cylinder installations. A single Model EN-MCU3 can be used to pneumatically actuate a maximum of five (5) agent cylinders with the 16 gram CO₂ cartridge. One (1) agent cylinder can be installed in the Model EN-MCU3 Enclosure; the additional agent cylinder(s) can either be mounted in a Model EN-S Enclosure or with a Model MB-15 Mounting Bracket. When an enclosure is used, the cylinders must be placed in the enclosure(s) with the discharge port to the left. **No additional mounting bracket is required when a cylinder is installed in the Model EN-MCU3 or EN-S Enclosure.**

In order to actuate the agent cylinders from the Model EN-MCU3, pneumatic tubing must be used to connect the EN-MCU3 actuator to the valve cap assembly of each agent cylinder valve. Pneumatic tubing or stainless steel actuation hose must be run from the actuator in the Model EN-MCU3 to the Model EN-S(s) through the side knockouts. A 1/4 in., 45° flare x 1/4 in., 45° flare x 1/8 in. NPT tee is included with the Model EN-S and must be installed in the Model EN-MCU3 actuator. See **Figure 4-36**.

NOTE

Pneumatic tubing (copper) used for remote cylinder actuation shall have an outside diameter of 1/4 in. (0.6 cm) with a minimum wall thickness of 1/32 in. (0.08 cm). This is commonly known as refrigeration-type copper tubing. All tubing fittings shall be of the 1/4 in., 45° flare type conforming to SAE J513c. **Compression type fittings are not acceptable.**

A single Model EN-MCU3 can actuate up to 4 cylinders with 25 ft. (7.6 m) of pneumatic tubing or stainless steel actuation hose or a maximum of five (5) cylinders with up to 18 ft. (5.4 m) of pneumatic tubing or stainless steel actuation hose.

System Checkout After Installation

Before putting the system into service, all components must be checked for proper operation. During this checkout, assure that the carbon dioxide pilot cartridge is not installed in the Model EN-MCU3 actuator. Remove the pull pin from the hole in the slide plate.

- ▶ To check satisfactory operation of the control mechanism, cut the terminal link or the “S” hook holding the link. This will relieve all tension on the fusible link line and operate the control mechanism. The slide plate will move fully to the right. The gas valve cable will be released, causing the gas valve to close. Any auxiliary equipment connected to the dry contacts of the solenoid monitor and/or the Electrical (Snap-Action) Switch in the Model EN-MCU3 will operate.

If any of these events fail to occur, the problem must be investigated and repaired.

Repair the terminal link and put the fusible link line back into the set position. This is accomplished by using a 1/2 in. hex wrench on the fusible link line ratchet wheel. The ratchet wheel will be ratcheted in a clockwise direction until the spring plate is parallel to the top of the enclosure.

Once the fusible link line is set, the control mechanism can be placed in the set position. To set the control mechanism, the slide plate is moved from right to left, ensuring the bolt extending from the cam arm is in the slot provided in the slide plate. Continue moving the slide plate to the left until the latching arm is in the locked position. Once the control mechanism is set, pull the pull handle on the remote pull station to assure that the control head operates. If the control mechanism operates normally, the control mechanism can be reset as described above. Insert the pull pin into the hole in the slide plate above the latching arm. Replace the pull station handle, pull pin, and nylon tie.

To test the thermal detectors, use a heat gun. Hold the gun approximately 12 in. (30.5 cm) from the detector for about one minute. Do not overheat. Overheating can cause damage to detector. Allow detector to cool after testing.

Assure that the gas valve is fully open by ratcheting the gas valve ratchet wheel. **Do not overtighten.**

CAUTION

Before screwing the 16 gram carbon dioxide pilot cartridge into the actuator, ensure that the actuator has an O-ring washer installed.

Using a felt-tipped marker, write the date of installation on the carbon dioxide pilot cartridge. Screw the cartridge into the Model EN-MCU3 actuator until hand-tight.

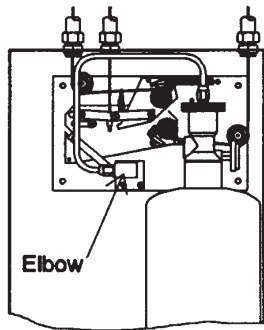

► Figure 4-35. Single Cylinder Installation with Model EN-MCU3 Mechanical Control Unit.

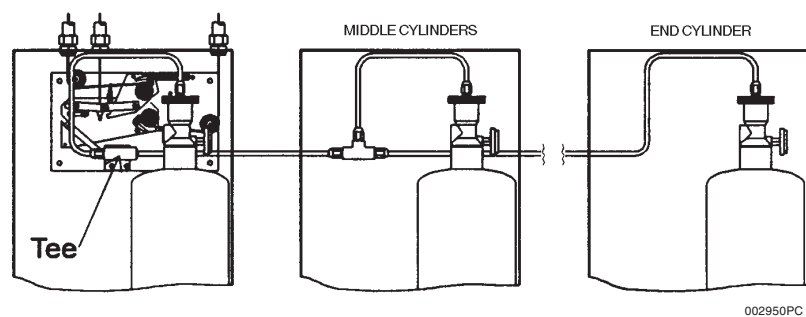

Figure 4-36. Multiple Cylinder Installation with Model EN-MCU3 Enclosure and Model EN-S Enclosure.

Install cartridge per the following:

- It is recommended that the cartridges first be fully hand tightened and then further tightened 1/4 to 3/4 turn using a needle-nose Vise-Grips. **Note: Use caution not to damage cartridge with Vise-Grips.**

Note 1: 4 to 5 threads should be showing when the cartridge is engaged properly. It is important that no more than 5 threads be showing.

Note 2: The cartridge and o-ring shall be replaced annually.

CAUTION

Do not over-tighten cartridge. Over-tightening can result in premature puncturing of the cartridge seal.

Remove the pull pin from the hole in the slide plate. Secure the Model EN-MCU3 or EN-S cover with the screws provided.

FLEXIBLE CONDUIT INSTALLATION

Flexible conduit allows for quicker installations and the convenience of being able to route the cable over, under, and around obstacles.

Flexible conduit is designed for use with PYRO-CHEM® restaurant systems. Flexible conduit can be used as a substitute for standard EMT conduit or can be used with EMT conduit.

Flexible conduit CANNOT be used in detection systems.

Design Requirements

- Prior to starting the flexible conduit installation, the detection system must be complete and attached to the control head.
- Flexible conduit **cannot** be utilized in detection systems.
- Flexible conduit inserts, Part No. 434347, can ONLY be used with the flexible conduit system.
- The maximum distance from a PYRO-CHEM control head to a mechanical pull station is 140 ft (42.7 m) with a maximum of 360° (for example, 3-90° and 2-45° bends, 2-90° and 4-45° bends, etc.) bends in the flexible conduit, one pulley tee (Refer to Design, Installation Manual for detailed splicing instructions), two splices, and 15 pulley tees. **Note:** When installing flexible conduit, make sure to feed wire rope through conduit directly from the spool of wire rope. DO NOT pre-cut wire rope. Feeding pre-cut rope through flexible conduit will cause excessive kinks in the rope, making it difficult to install.
- The maximum distance from a PYRO-CHEM control head to a mechanical gas valve is 75 ft (22.9 m) with a maximum of 4-90° bends in the flexible conduit and 4 pulley elbows.
- Any portion of the flexible conduit system can be substituted with EMT conduit provided the proper connections are used to join the two types of conduit.
- All bends in the flexible conduit system must have a minimum bend diameter of 6 in. (15 cm).
- When the flexible conduit is used to make 90° bends between a control head and a mechanical gas valve, the bends must start at the control head. No pulley elbows can be used between the bends. If more than 360° of bends are needed, then pulley elbows can be used.
- When the flexible conduit is used to make 90° bends between a control head and a pull station, the bends must start at the control head. No pulley elbows can be used between the bends. If more than 360° of bends are needed, then pulley elbows can be used.
- Only PYRO-CHEM pull stations utilizing a composite (black) bushing on the back side of the pull station cover can be used with flexible conduit.

- When not utilizing a conduit offset, Part No. 436063, 2-45° bends in the flexible conduit are allowed between the strain relief on top of the control head and the location where the flexible conduit is supported. **Note: This is allowed on pull station installations only.**
- When installing flexible conduit, conduit should be secured at intervals not to exceed 5 ft (1.5 m) and before and after each bend. Flexible conduit CANNOT slide in the clamp(s) used for mounting. Make certain mounting clamp(s) do not pinch the flexible conduit. The following style clamp ('P' clip), Part No. 436150, is a suitable type for use on flexible conduit.

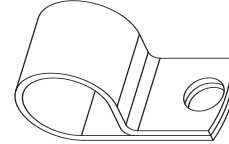

Figure 4-37.
008141

TABLE 1

	Manual Pull	Mechanical Gas Valve	Detection
90° Cable Bends	4	4	N/A
Bend Diameter – in. (cm)	6 (15.2)	6 (15.2)	N/A
Mechanical Corner Pulley	15	4	N/A
Conduit Secured Max. ft (m)	5 (1.5)	5 (1.5)	N/A
Conduit Max. Length ft (m)	140 (42.7)	75 (22.9)	N/A
Conduit Offset or 2-45°	1	0	N/A
Bends (Only between the strain relief fitting and support location)			
Pulley Tees	1	0	N/A
Splices	2	0	N/A

Installation Instructions

Note: Do not add any type of lubricants inside or on the flexible conduit. Make certain stainless steel wire rope is clean and debris-free.

The flexible conduit should be routed along the same path that EMT conduit would normally be run. Stainless steel wire rope should be routed through the flexible conduit as it is in EMT conduit.

CAUTION

Flexible conduit must not be located within 6 in. (15 cm) of the hood or in areas exceeding 130 °F (54 °C). Also, do not route flexible conduit in areas where conduit can be crushed, pinched, or broken.

Flexible conduit can be used to connect a PYRO-CHEM control head to a remote pull station or mechanical gas valves.

Before starting the system installation, take a few minutes to plan the layout of the system. This will minimize the amount of components needed to complete the installation. Once the path of the flexible conduit has been determined, verify that the layout does not exceed the design requirements.

Connecting the Flexible Conduit to the PYRO-CHEM Control Head, Electrical Box, Pull Station, or Mechanical Gas Valve

1. Layout the flexible conduit and secure it in place. **Note:** If inner liner is crimped, turn a drywall screw into the end to open it. See **Figure 4-38**.



Figure 4-38.
007985

2. Starting at the PYRO-CHEM control head, connect the conduit connector using the supplied nut. Use only PYRO-CHEM conduit fittings, Part No. 55813. See **Figure 4-39**.



Figure 4-39.
008068

3. Unscrew the nut from the EMT conduit connector and remove the compression ring. Discard ring. See **Figure 4-40**.

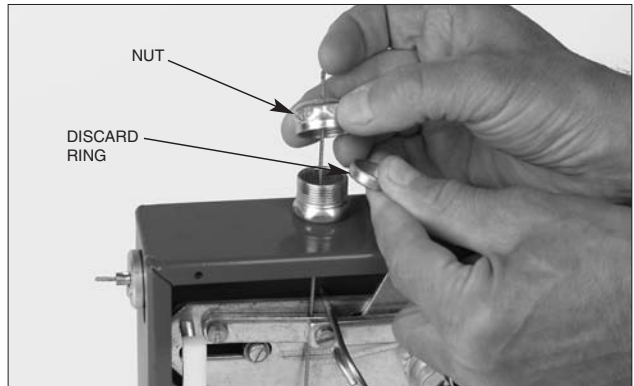

Figure 4-40.
008070

4. Thread the stainless steel wire rope through the EMT conduit connector and flexible conduit insert. Make certain thread in flexible conduit insert is facing out toward end of connector. See **Figure 4-41**.

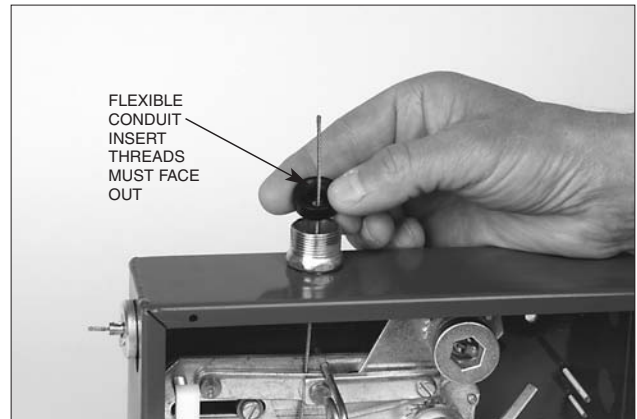

Figure 4-41.
008071

5. Tighten the nut to the connector body, locking the flexible conduit insert in place. See **Figure 4-42**.

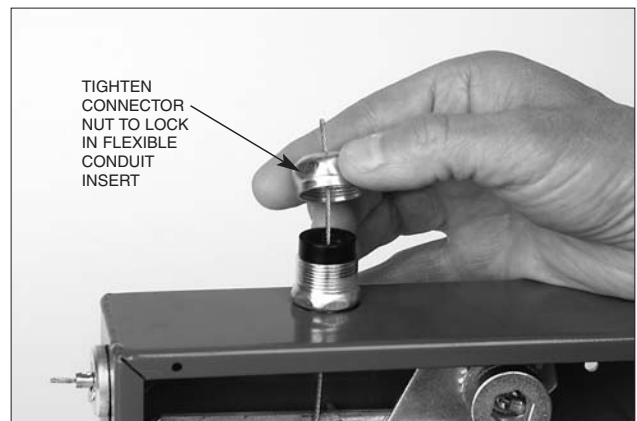

Figure 4-42.
008072

▶ **Connecting the Flexible Conduit to the PYRO-CHEM Control Head, Electrical Box, Pull Station, or Mechanical Gas Valve (Continued)**

6. Loosen the nut on the strain relief and thread the wire rope through the strain relief. See **Figure 4-43**.

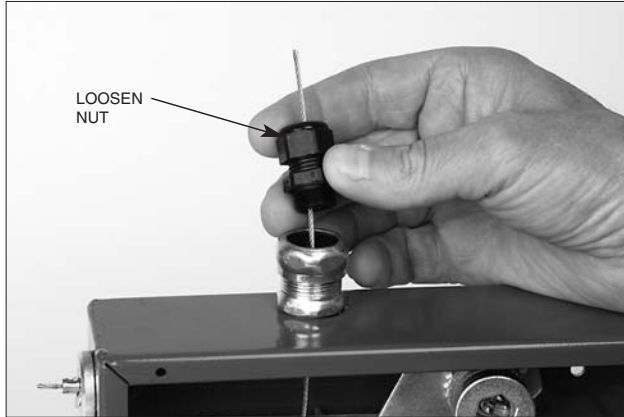

Figure 4-43.
008073

7. Tighten the body of the strain relief to the conduit connector. See **Figure 4-44**.

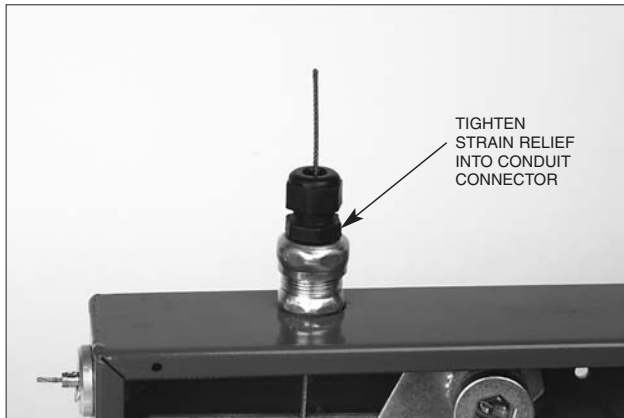

Figure 4-44.
008074

- ▶ 8. Thread the wire rope through the flexible conduit. See **Figure 4-45**. (If a splice is required in the flexible conduit, proceed to “Splicing Installation Instructions.”)



Figure 4-45.
008075

9. Slide the flexible conduit into the strain relief until it is approximately 1/16 in. (2 mm) from the bottom of the flexible conduit insert. See **Figure 4-46**.

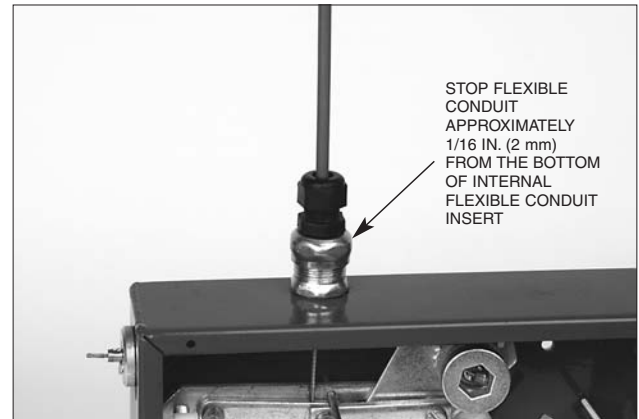

Figure 4-46.
008076

10. Tighten the strain relief nut onto the strain relief. See **Figure 4-47**.

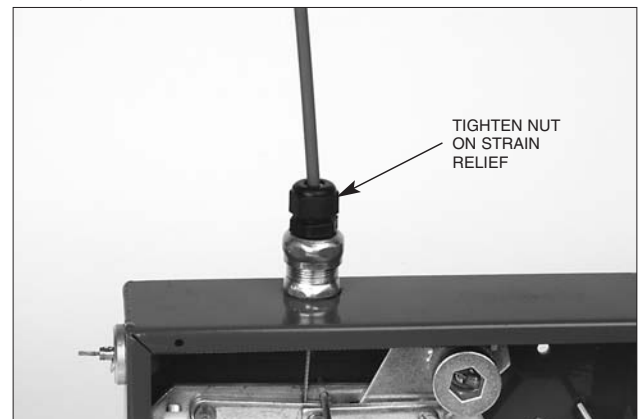

Figure 4-47.
008077

Connecting Flexible Conduit to Pulley Elbows, Pulley Tees, or Union Fittings

1. Unscrew the nut from pulley elbow, pulley tee, or EMT conduit connector and remove the compression ring. Discard ring. See **Figure 4-48**.

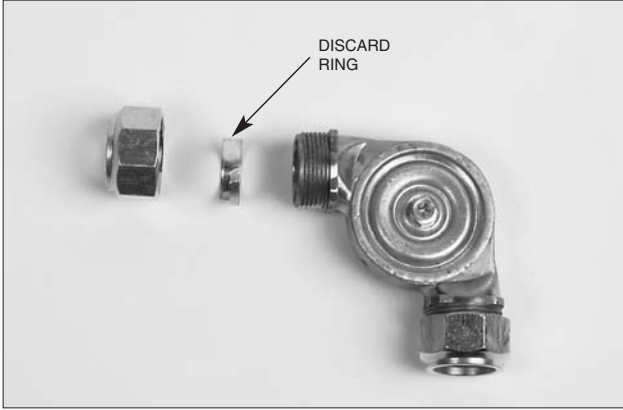

Figure 4-48
007995

2. Thread the stainless steel wire rope through the EMT conduit connector and flexible conduit insert. Make certain thread in flexible conduit insert is facing out toward end of connector. See **Figure 4-49**.

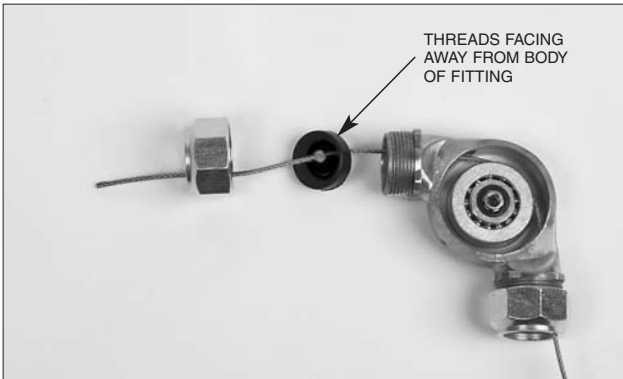

Figure 4-49.
007996

3. Tighten the nut to the connector conduit body, locking the flexible conduit insert in place. See **Figure 4-50**.

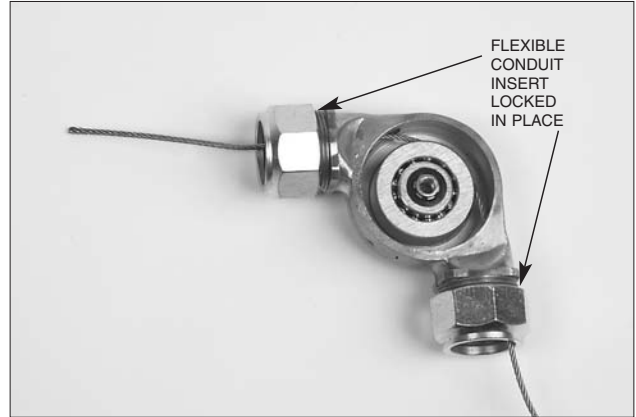

Figure 4-50
007997

4. Loosen the nut on the strain relief and thread the wire rope through the strain relief. See **Figure 4-51**.

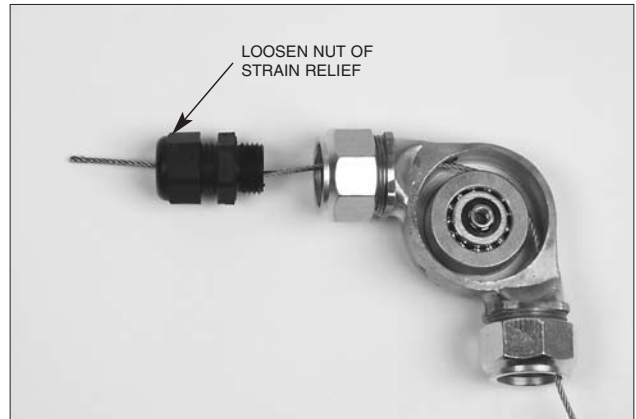

Figure 4-51.
007998

5. Tighten the body of the strain relief to the conduit connector. See **Figure 4-52**.

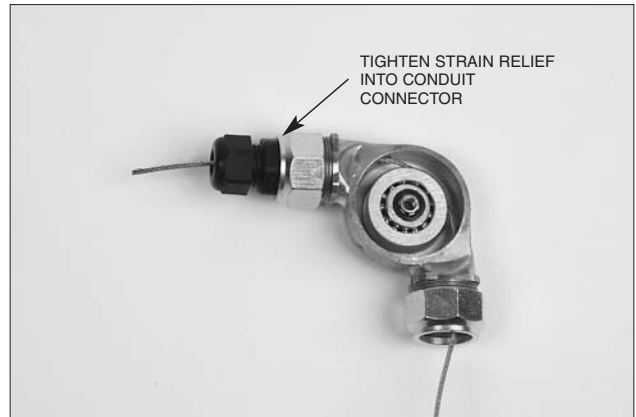

Figure 4-52.
007999

Connecting Flexible Conduit to Pulley Elbows, Pulley Tees, or Union Fittings (Continued)

6. Push the wire rope into the flexible conduit. See **Figure 4-53**.

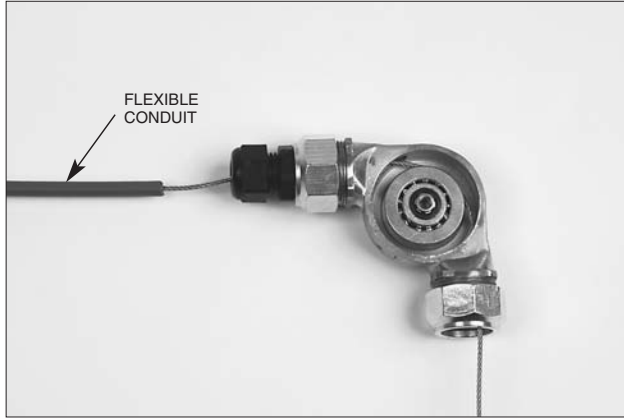

Figure 4-53.
008000

7. Slide the flexible conduit into the strain relief until it is approximately 1/16 in. (2 mm) from the bottom of the flexible conduit insert. See **Figure 4-54**.

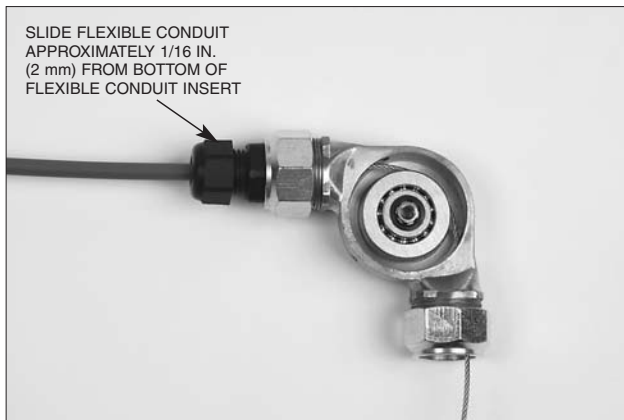

Figure 4-54.
008001

8. Tighten the strain relief nut onto the strain relief. See **Figure 4.55**.

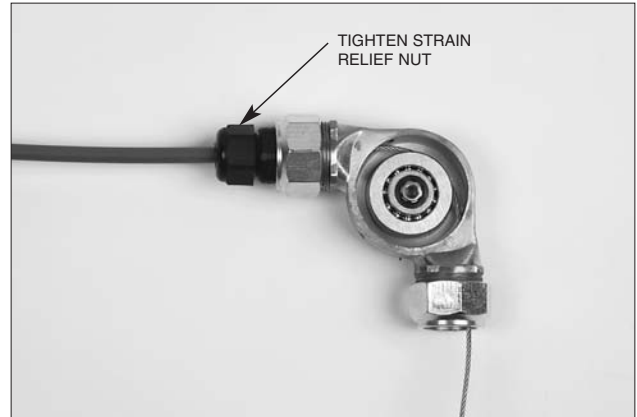

Figure 4-55.
008002

9. Complete the same procedures on the other end of the conduit fitting as described in Step 1 through Step 8 above.

▶ Installing Flexible Conduit Through a Conduit Offset

1. Starting at the PYRO-CHEM control head, connect the conduit connector using the supplied nut. Use only PYRO-CHEM conduit fittings, Part No. 55813. See **Figure 4-56.**

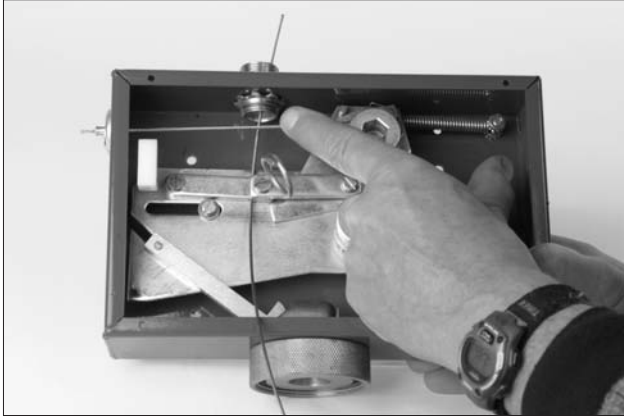

Figure 4-56.
008068

2. Install Conduit Offset, Part No. 79825, into conduit connector and tighten nut. See **Figure 4-57.**



Figure 4-57.
008069

3. Install compression union to opposite end of conduit offset. Tighten securely. See **Figure 4-58.**



Figure 4-58.
008040

4. Install the conduit required to get above the ceiling. See **Figure 4-59.**



Figure 4-59.
008041

5. Install compression union to top of conduit riser. See **Figure 4-60.**



Figure 4-60.
008042

▶ Installing Flexible Conduit Through a Conduit Offset (Continued)

6. Remove union nut and ring. Discard ring. Do not reinstall nut at this time. See **Figure 4-61**.



Figure 4-61.
008043

7. Remove strain relief nut and install strain relief body into compression union. See **Figure 4-62**.



Figure 4-62.
008044

- ▶ 8. Install union nut over strain relief body and tighten nut. See **Figure 4-63**.



Figure 4-63.
008045

9. Install strain relief nut onto strain relief body. Do not tighten nut at this time. See **Figure 4-64**.



Figure 4-64.
008046

10. Push flexible conduit completely through conduit offset. Flexible conduit should stop flush or +/- 1/2 in. (1.3 mm) from bottom of conduit of conduit fitting in PYRO-CHEM control head. See **Figure 4-65**.



Figure 4-65.
008047

▶ Installing Flexible Conduit Through a Conduit Offset (Continued)

11. Tighten nut on strain relief on top of conduit riser. See **Figure 4-66**.

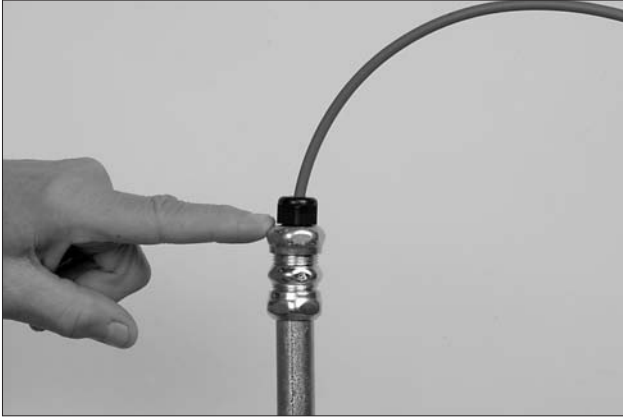

Figure 4-66.
008048

12. Complete the remainder of the flexible conduit and wire rope installation to the pull station or the gas valve.

Flexible Conduit Splicing (Allowed on Pull Station Installations Only)

Note: Wire rope cannot be spliced together, only the flexible conduit.

Flexible conduit can be spliced together using EMT compression fitting union, Part No. 79827, only for the pull connection.

1. Remove rings from both ends of compression union. See **Figure 4-67**.

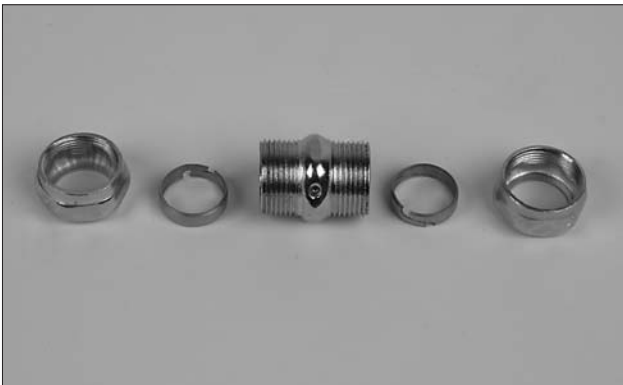

Figure 4-67.
008061

2. Install strain relief nut, strain relief, compression union nut, flexible conduit insert and compression union over the flexible conduit with wire rope installed. See **Figure 4-68**.



Figure 4-68.
008049

3. Tighten compression union nut onto union body, locking flexible conduit insert in place. See **Figure 4-69**.

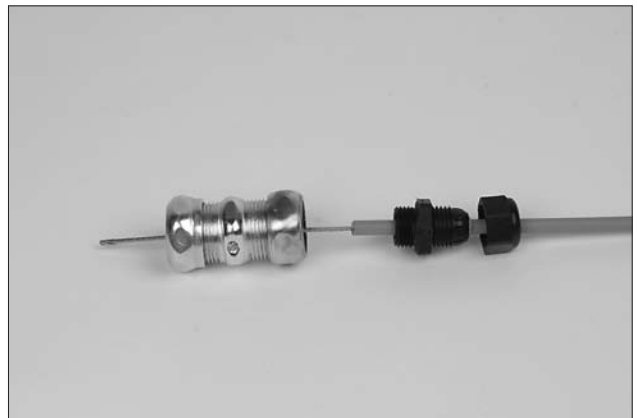

Figure 4-69.
008050

4. Install strain relief body into compression union and tighten. See **Figure 4-70**.



Figure 4-70.
008051

► **Flexible Conduit Splicing (Allowed on Pull Station Installations Only) (Continued)**

5. Push flexible conduit into strain relief until it is approximately 1/16 in. (2 mm) from the bottom of the flexible conduit insert, then tighten strain relief nut onto strain relief body. See **Figure 4-71**.



Figure 4-71.
008052

6. Starting on the opposite end of the compression union, remove the nut. See **Figure 4-72**.



Figure 4-72.
008053

7. Install strain relief nut, strain relief, and compression union nut on remaining section of flexible conduit and install flexible conduit insert on wire rope. See **Figure 4-73**.



Figure 4-73.
008054

8. Push wire rope completely through remaining section of flexible conduit. See **Figure 4-74**.



Figure 4-74.
008055

9. Tighten compression union nut onto union body, securing flexible conduit insert in place. See **Figure 4-75**.



Figure 4-75.
008056

► Flexible Conduit Splicing (Allowed on Pull Station Installations Only) (Continued)

10. Tighten strain relief body into compression union. See **Figure 4-76**.



Figure 4-76
008057

11. Push flexible conduit into strain relief until it is approximately 1/16 in. (2 mm) from bottom of the flexible conduit insert, then tighten strain relief nut onto strain relief body. See **Figure 4-77**.



Figure 4-77
008058

12. Complete the remainder of the flexible conduit and wire rope installation.
13. To test all installations, refer to the proper sections in the KITCHEN KNIGHT® II Technical Manual, Part No. 551274.

Testing Pull Station/Mechanical Gas Valve

To test all installations, refer to KITCHEN KNIGHT II Technical Manual, Part No. 551274, Chapter 4 (System Installation) for detailed testing information.

CHAPTER V SYSTEM MAINTENANCE

GENERAL

▶ The maintenance information listed in this section deals with the limitations and parameters of this pre-engineered system. Those individuals responsible for the maintenance of the KITCHEN KNIGHT II system must be trained and hold a current PYRO-CHEM certificate in a KITCHEN KNIGHT II training program.

SEMI-ANNUAL MAINTENANCE

1. Check that the hazard area has not changed.
 2. Check that the system has not been tampered with, i.e., nozzles removed, nozzles not aimed properly, piping not supported properly, blow off caps in place.
 3. Check the entire system for mechanical damage.
 4. Check all nozzle orifices to make certain they are not plugged. Replace blow off caps or O-ring if necessary.
- ▶ **Note:** Rubber blow-off caps that have been installed in the system for one year or more must be replaced.
5. Check the solenoid monitor.

CAUTION

Before continuing, remove the cover from the control head and insert the safety pin in the hole in the slide plate above the latching arm. This will secure the system, preventing accidental discharge.

6. Disconnect the control head or pneumatic tubing from the valve cap assembly of each agent cylinder. Remove the carbon dioxide pilot cartridge in the control head. Remove the safety pin from the slide plate. Actuate the control head to ensure it is functioning properly. Make certain the gas shut-off valve and remote pull station are functioning properly.
7. Inspect the pulley elbows for excessive grease buildup. Clean elbows if necessary. Replace fusible links. (They must be replaced semi-annually per NFPA 96.) Visually inspect thermal detectors.

NOTE

Methods and frequency of inspection, testing and maintenance of detectors should be in accordance with NFPA-72.

8. Reinstall the carbon dioxide pilot cartridge, reconnect the control head, and replace the control head cover and nylon tie. See detailed cartridge installation instructions listed on Page 4-20 (System Installation).

CAUTION

Before screwing the carbon dioxide pilot cartridge into the actuator, ensure that the actuator has an O-ring installed. If actuator is utilizing a Teflon washer, replace with O-ring, Part No. 55531.

9. Inspect the cylinder pressure. Tap the gauge lightly to ensure the needle is moving freely. If the gauge shows a loss in pressure indicated by the needle being below the green band, the tank should be removed and recharged per the SYSTEM RECHARGE section of Chapter VI (System Recharge) in this manual.

ANNUAL MAINTENANCE

1. Inspect as per semi-annual maintenance instructions. Do not reconnect control head at this time.
2. Disconnect the discharge piping from the valve outlet. Using air or nitrogen, blow out the piping. Replace all nozzle caps.
3. Fixed temperature sensing elements of the fusible alloy type must be replaced, at a maximum semi-annually, or more frequently if necessary, to assure proper operation of the system.
4. Test thermal detectors and remote pull stations per SYSTEM CHECKOUT AFTER INSTALLATION section located in Chapter IV (System Installation) of this manual. Per NFPA 72, two (2) or more detectors per circuit should be tested. Note individual detector location and date of testing. Within 5 years, all detectors in system must be tested.
5. Replace the carbon dioxide pilot cartridge and O-ring (Part No. 55531).
6. Record the date of installation on the cartridge with a felt-tipped marker.
7. See detailed cartridge installation instructions listed on Page 4-20 (System Installation).

CAUTION

Before screwing the carbon dioxide pilot cartridge into the actuator, ensure that the actuator has an O-ring installed.

- ▶ 8. Reconnect the control head. Replace the control head cover and nylon tie.

12-YEAR MAINTENANCE

Along with the required annual maintenance requirements, the tanks must be removed from the system, properly discharged, and hydrostatically tested per the requirements of NFPA-17A. The tank should be refilled with fresh agent.

NOTE

Refer to the nameplate on tank for hydrostatic pressure requirements.

CHAPTER VI SYSTEM RECHARGE

GENERAL

- ▶ The recharge information listed in this section deals with the limitations and parameters of this pre-engineered system. Those individuals responsible for the recharge of the KITCHEN KNIGHT II system must be trained and hold a current PYRO-CHEM certificate in a KITCHEN KNIGHT II training program.

SYSTEM CLEANUP

CAUTION

Before attempting any cleanup, make certain that all fuel sources to the equipment to be cleaned have been shut off. Make certain that the exhaust hood and all appliance electrical controls have been de-energized to avoid any chance of electrical shock resulting from the cleaning process of electrically conductive alkaline liquid agent and/or its residue.

Make certain all surfaces to be cleaned have cooled down to room temperature.

Do not use water to clean any appliances that contain hot grease or cooking oils. Doing so may result in violent steaming and/or spattering.

CAUTION

Do NOT use a wrench or other tool to tighten the valve. Do NOT use a pipe extension on the valve outlet for the purpose of providing additional torque.

SYSTEM RECHARGE

NOTE

Determine the cause of system discharge and correct immediately before performing system recharge.

1. After discharge, inspect the entire system for mechanical damage. If the tank has sustained any mechanical damage, it must be hydrostatically tested before refilling.
2. Disconnect the 1/4 in. actuation tubing or the control head from the top of the tank valve.
3. Relieve the pressure from the top chamber of the tank valve by depressing the core of the valve in the valve cap assembly. By performing this operation, the valve will close.
4. Slowly remove the valve and siphon tube. If there is any residual pressure left in the tank, it will bleed out through the pressure relief slot in the valve threads.
5. **The complete piping system must be flushed after a discharge.** Flushing concentrate, Part No. 79656, must be used when flushing the system. The concentrate is shipped in a 32 oz (0.95 L) container. A PCL-160 tank requires 1/2 of a container. A PCL-300 tank requires 1 container of concentrate. A PCL-460 requires 1 1/2 containers, and a PCL-600 requires 2 containers. To prepare the system for flushing:
 - a. Pour the required amount of flushing concentrate into the tank.
 - b. Fill the tank approximately half full with warm, clear water. Agitate the tank for a few seconds and then add more warm water to bring the level to the required fill line using the measuring stick, Part No. 551039.
 - c. Reinstall valve and pickup tube. Hand tighten to 12.5 foot pounds maximum torque.
6. Pressurize tank to 225 psi (15.5 bar) at 70 °F (21 °C) and reinstall to piping network.
7. With nozzles in place, attach control head and manually actuate the tank. Allow the tank to completely discharge through the piping network.
8. After the discharge is completed, the entire piping network must be blown out with air or nitrogen until no more mist is visual coming out of the nozzles.
9. Remove, clean, and reinstall all nozzles.
10. Remove the tank from the system. Slowly remove the valve and siphon. If there is any residual pressure left in the tank, it will bleed out through the pressure relief slot in the valve threads. The valve and pressure regulator (located in outlet of valve) must be cleaned and rebuilt after each discharge. To rebuild the valve, use rebuilding kit, Part No. 550698. To rebuild the pressure regulator, use rebuilding kit, Part No. 551061. Each kit includes an instruction sheet listing detailed rebuilding instructions.
10. Fill tank with required amount of KITCHEN KNIGHT agent, Part No. 551188 (3 gal) or Part No. 553176 (1.6 gal), using measuring stick, Part No. 551039. Tank should be filled to a tolerance of $-0/+1/8$ in. ($-0/+0.3$ cm) from the mark level on the measuring stick.

NOTE

During filling, the agent temperature should be 60 °F to 80 °F (16 °C to 27 °C).

NOTE

The pressure gauge attached to the tank valve should not be used to determine when the charging pressure has been reached. A calibrated external gauge must be used.

NOTE

The pressure regulator in the valve outlet must be removed before pressurizing.

11. Reinstall valve and pickup tube. Hand tighten to 12.5 foot pounds maximum torque. Pressurize Shrader valve assembly with 150 psi (10.3 bar) of nitrogen. Install recharge adaptor, Part No. 551240, into the valve outlet and pressurize with nitrogen to 225 psi (15.5 bar) at 70 °F (21 °C). Wait 10 minutes and verify the pressure in the tank is at 225 psi (15.5 bar). Relieve the pressure from the Shrader valve assembly (this will cause the valve to close) and then disconnect the recharge adaptor. Reinstall pressure regulator into valve outlet.

CAUTION

If pressure is not relieved from Shrader valve assembly before the recharge adaptor is removed, the tank will discharge.

12. Replace all fusible links by following the instructions listed in the Installation Section.
13. Reset control head(s), accessories, pull stations and gas valves by following the instructions listed in the Installation Section.

NOTES:



NOTES: