

TYAN™

Tiger 200T S2505T

User's Manual Revision 1.01

Copyright © Tyan Computer Corporation, 2001. All rights reserved. No part of this manual may be reproduced or translated without prior written consent from Tyan Computer Corp.

All registered and unregistered trademarks and company names contained in this manual are property of their respective owners including, but not limited to the following.

Tiger 200T S2505T is a trademark of Tyan Computer Corporation.

Intel, Pentium III, Celeron are registered trademarks of Intel Corporation.

VIA, Apollo Pro133T are trademarks of VIA Technologies, Inc.

Promise, FastTrak100, FastBuild are registered trademarks of Promise Technology, Inc.

AwardBIOS is a trademark of Phoenix Software.

Windows is a trademark of Microsoft Corporation.

IBM, PC, AT, PS/2 are trademarks of IBM Corporation.

Information contained in this document is furnished by Tyan Computer Corporation and has been reviewed for accuracy and reliability prior to printing. Tyan assumes no liability whatsoever, and disclaims any express or implied warranty, relating to sale and/or use of Tyan products including liability or warranties relating to fitness for a particular purpose or merchantability. Tyan retains the right to make changes to product descriptions and/or specifications at any time, without notice. In no event will Tyan be held liable for any direct or indirect, incidental or consequential damage, loss of use, loss of data or other malady resulting from errors or inaccuracies of information contained in this document.

Table of Contents

Before you begin...	Page 4
Chapter 1: Introduction	5
1.1 Congratulations!	5
1.2 Hardware Specifications	6
1.3 Software Specifications	7
Chapter 2: Board Installation	8
2.1 Installation	8
2.2 How to install our products right... the first time	8
2.3 Here are some safety tips	8
2.4 Quick Reference for Jumpers	9
2.5 Map of Motherboard Jumpers	10
2.6 Setting up Jumpers and Onboard Connectors	11
2.6-A Front Panel Connector	11
2.6-B CMOS Reset	11
2.6-C IDE RAID Enable/Disable	12
2.6-D Onboard VGA Enable/Disable	12
2.6-E FAN Connectors	13
2.6-F CPU Frequency Ratio Jumpers	13
2.6-G Serial Port Connector	14
2.6-H USB Connector	14
2.6-I Wake-on-Ring, Wake-on-LAN	15
2.6-J IDE RAID Connectors	15
2.6-K Soft Power Connector Installation	16
2.6-L Hardware Reset Switch Connector Installation	16
2.6-M Flash Utility	17
2.7 Mounting the Motherboard in the Chassis	18
2.8 Installing Memory	19
Removing a DIMM	20
Buffered vs. Unbuffered Memory	20
Suggested Memory Configurations	21
2.9 Installing the CPU and Cooling Fan	22
Installing the CPU	22
Installing the Cooling Fan(s)	23
2.10 Connecting IDE and Floppy Drives	24
Connecting Floppy Drives	25
2.11 Installing Add-on Cards	26
2.12 Connecting PS/2, USB, and Serial Devices	27
2.13 Connecting the Power Supply	28
2.14 You are done!	29
2.15 Frequently Asked Questions (FAQ)	30
Chapter 3: BIOS Setup	31
Introduction to the BIOS Setup	31
Starting Setup	31
Setup Keys	32
Getting Help	32
In Case of Problems	32
Setup Variations	32

3.1	Main Setup	33
3.2	Standard CMOS Setup	33
3.2-A	Date/Time	33
3.2-B	IDE Primary/Secondary Master/Slave	33
3.2-C	Table of IDE device settings	34
3.2-D	Memory	35
3.3	Advanced BIOS Features	35
3.4	Advanced Chipset Features	37
3.5	Integrated Peripherals	38
3.6	Power Management Setup	39
3.7	PnP/PCI Configuration	41
3.8	PC Health Status	41
3.9	Frequency/Voltage Control	42
3.10	Set Supervisor Password / Set User Password	42
3.11	Exit BIOS Setup	42
Chapter 4: System Resources		43
4.1	Beep Codes	43
4.2	Flash Utility	43
Appendix I: RAID Installation*		44
	Promise FastTrak100 RAID Configuration Utility	44
Appendix II: Glossary		50
	Technical Support	56
	Returning Merchandise for Service	56

* optional feature available on some Tiger 200T models

Before you begin...

Check the box contents!

The retail motherboard package should contain the following:



Tiger 200T S2505T motherboard



34-pin floppy cable

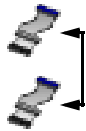

(2) UltraDMA-100/66/33 IDE cables
(optional on some Tiger 200T models)



I/O shield* (optional on some Tiger 200T models)



Tiger 200T user's manual



Tyan driver CD

If any of these items are missing, please contact your **vendor/dealer** for replacements before continuing with the installation process.

* If you require a different I/O shield solution, please contact your chassis vendor

Chapter 1: Introduction

1.1 Congratulations!

You now own one of the premier dual processing solutions on the market!

The Tiger 200T is a high performance motherboard designed for server and performance applications that require the power of dual Intel® Pentium™ III FC-PGA processors (universal) or a single Celeron™ FC-PGA processor. This motherboard utilizes the VIA Apollo Pro133T chipset and can support CPU speeds of 500 MHz through 1.13+ GHz and front side bus speeds of 100 MHz or 133 MHz. Please see Tyan's website for updates and information concerning CPU information and support:

<http://www.tyan.com>

This integrated performance board is supported in an ATX form factor. Some of the features included are onboard UltraDMA-100/66/33 support, and (**optional**) Promise® IDE RAID.

With I/O and drive controller support onboard, the five 32-bit PCI v2.2 slots and one ISA slot are free for numerous types of add-on expansion cards. The four 168-pin DIMM sockets can support up to 2GB* of buffered or unbuffered PC100 SDRAM, or up to 1.5GB of buffered or unbuffered PC133 SDRAM.

Remember to visit Tyan's website at **<http://www.tyan.com>**. There you can find information on all of Tyan's products with FAQs, distributors list, and BIOS settings explanations.

* check the Tyan website for updated details on memory compatibility: **<http://www.tyan.com>**

1.2 Hardware Specifications

Processor Information	Dual Universal PGA370 ZIF Sockets Intel Pentium III (FC-PGA) 500MHz - 1.13GHz+ Celeron (single socket configuration only) FC-PGA Onboard VRM 8.5 spec Front side bus support for 100 or 133MHz
Expansion Slots	Five 32-bit PCI v2.2 compliant slots One ISA slot Total six usable slots
Chipset Information	VIA Apollo Pro133T chipset (VT82C694T and VT82C686B)
Hardware Monitoring	Integrated hardware monitoring 3-pin Fan Monitoring headers Temperature and Voltage Monitoring 3-pin Wake-on-Ring header 3-pin Wake-on-LAN header
Memory	Four 168-pin 3.3V DIMM sockets Supports 1.5GB of 66/100/133MHz types of memory. Supports both buffered/unbuffered PC100/133 SDRAM
Integrated PCI IDE	Dual-channel master mode Supports up to four Enhanced IDE devices Support for UltraDMA-100/66/33 IDE devices and ATAPI compliant devices
Integrated I/O	One floppy connector for up to two drives Two 9-pin UART serial ports One 25-pin ECP/EPP parallel port Four USB ports (two ports via cable - optional *) PS/2 mouse and keyboard ports
Integrated IDE RAID (manufacturing option)	Promise FastTrak100 IDE RAID controller 0/1/0+1 RAID options Dual-channel master mode Support for UltraDMA-100/66/33 IDE devices
Integrated 2D/3D graphics	ATI Rage XL PCI Accelerator 4 MB (or 8MB***) 1Mx16 SDRAM frame buffer Standard 15-pin analog VGA port

* Extra accessories can be purchased at the Tyan Online Store: <http://www.etyan.com>

*** 8MB may be available on some Tiger 200T models. Check the Tyan website for updates:
<http://www.tyan.com>

^ If your chassis supports frontside USB cables, it will usually come with those cables.
Check with your chassis vendor for details. Tyan does not provide frontside USB cables.

BIOS

Award BIOS 2 (or 4****) Mbit Flash
Auto-detection of memory size
Auto-configuration of IDE hard disk types
User settings of hardware monitoring
Multiple boot options
DMI 2.0 compliant

Form Factor

ATX 2.03 (12" x 9.6", 304.8mm x 243.84 mm)
One 20-pin ATX power connector
Stacked mouse & keyboard ports
Stacked two USB ports
Two serial ports, one parallel port

Regulatory

FCC (Declaration of Conformity)
European Community CE (Declaration of Conformity)

1.3 Software Specifications

OS

Operates with Windows 98/SE/ME,
Windows NT[^]/2000

**** 4 Mbit BIOS may be available on some Tiger 200T models. Check the Tyan website for updates:
<http://www.tyan.com>

[^] Memory support dependent on operating system used. Check the Tyan website for updated details
on memory support for the Tiger 200T: <http://www.tyan.com>

Chapter 2: Board Installation

2.1 Installation

Once you've checked that everything is inside the box (see p. 4 for details), you are then ready to install your motherboard. The mounting hole pattern of the motherboard matches the ATX board specifications, so your chassis must be capable of supporting an ATX board (check the motherboard dimensions provided on p. 7).

2.2 How to install our products right.. the first time.

Question: what's the first thing I should do?

The first thing you should do is read the **user's manual**. It contains important information which will make configuration and setup much easier, as well as provide information on device installation and component setup. By reading through the manual completely before installing your motherboard, you will have a complete overview on the installation.

2.3 Here are some safety tips:

- (1) **Ground yourself properly before removing your motherboard from the antistatic bag.** Unplug the power from your computer power supply and touch any metal part on the computer case. (You might also want to wear a grounded wrist strap.)
- (2) **Hold the motherboard by its edges and do not touch the bottom of the board.**
- (3) **Avoid touching motherboard components, IC chips, connectors, and leads.**
- (4) **Avoid touching pins of memory modules and chips.**
- (5) **Place motherboard on a grounded surface or on the antistatic bag.**

Having reviewed the precautions above, the next step is to take the motherboard out of the cardboard box and static bag, hold it by its edges, and place it on a grounded antistatic surface (such as the bag it came in), component side up. Then, inspect the board for damage.

NOTE:**DO NOT APPLY POWER TO THE BOARD IF IT HAS BEEN DAMAGED!**

Press down on any of the socketed ICs if it appears that they are not properly seated (the board should still be on an antistatic mat or on top of the bag it came in). Do not touch the bottom of the board. Remember, don't take any electronic device out of its protective bag until you are ready to actually start installing it into the computer case (e.g. setting jumpers, etc.) If you do not ground yourself, you risk zapping the motherboard or adapter card. Subsequent problems may not arise immediately because electrostatic discharge, unlike physical damage, causes the device to fail over time.

2.4 Quick References for Jumpers

In this manual, the term “closed” and “on” are used when referring to jumpers (or jumper pins) that are active; “open” and “off” are used when referring to jumpers (or jumper pins) that are inactive. See **Figure 2.0a** and **Figure 2.0c** for examples of “on” and “off” pins and jumpers.

Jumpers and pins are connected by slipping the plastic jumper connector over the top of two adjacent jumper pins (indicated by 1-2 or 2-3). The metal rod inside the plastic shell bridges the gap between the two pins, completing the circuit. See **Figure 2.0b** and **Figure 2.0d** for more examples of 3-pin jumper connections. NOTE: The small number “1” indicates pin 1.

The tables and maps on the following pages will help you set the jumpers for CPU speed, infrared, and external connector pin assignments, among others. The miniature motherboard maps will help you locate the jumpers on your board. Full page maps of the motherboard can be found on the next two pages.

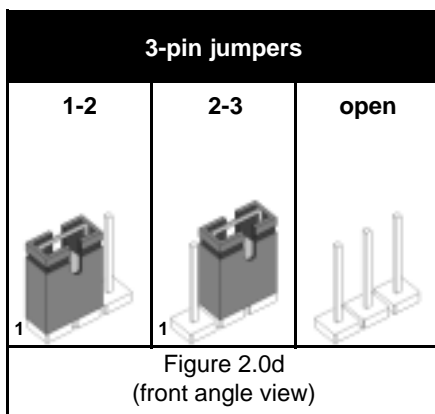
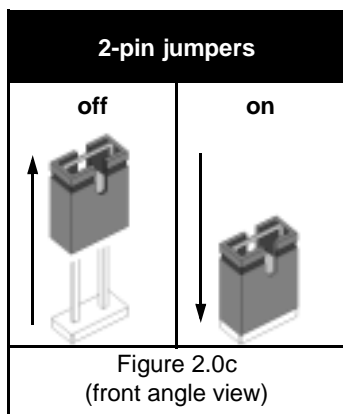
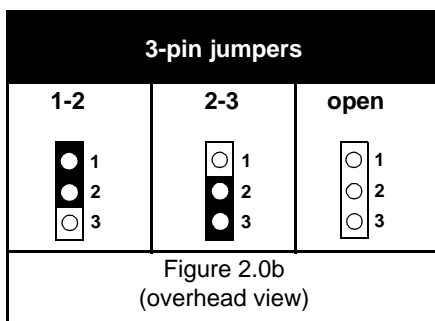
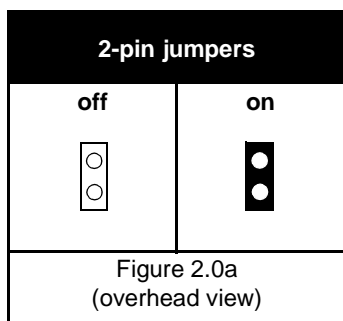

2.5 Map of Motherboard Jumpers

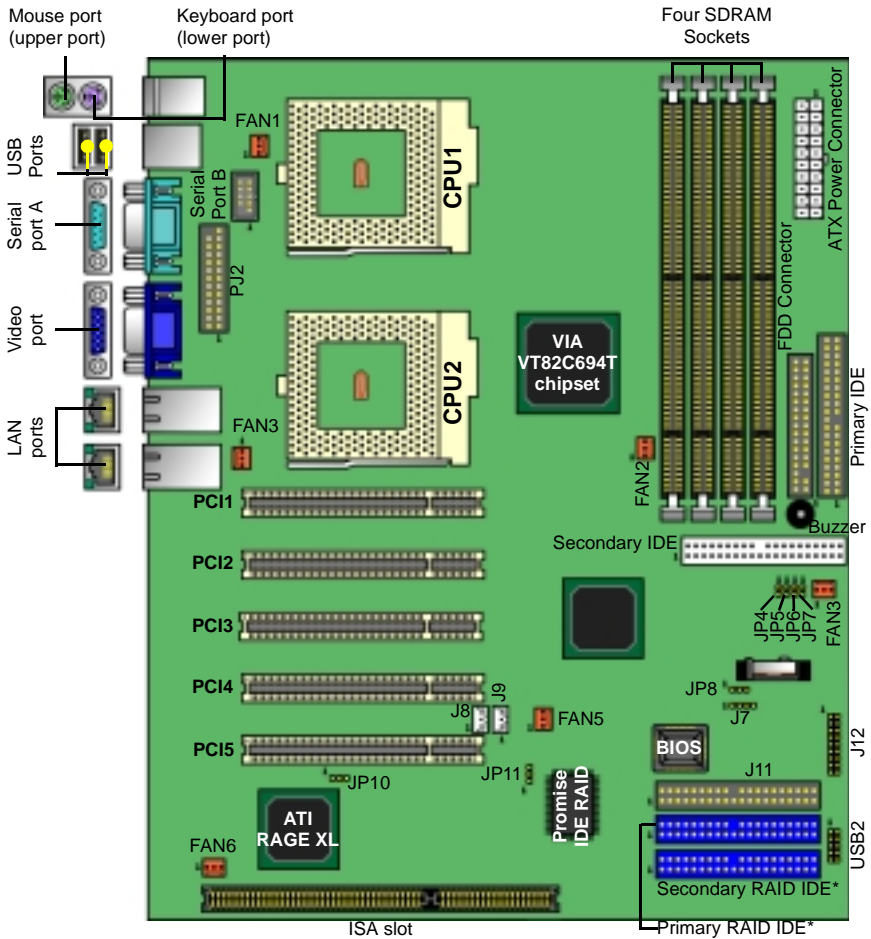

* optional feature available on some Tiger 200T models

2.6 Setting up Jumpers and Onboard Connectors

Pinouts for certain connectors are available on the Tyan website: <http://www.tyan.com>

2.6-A. Front Panel Connector (J12)

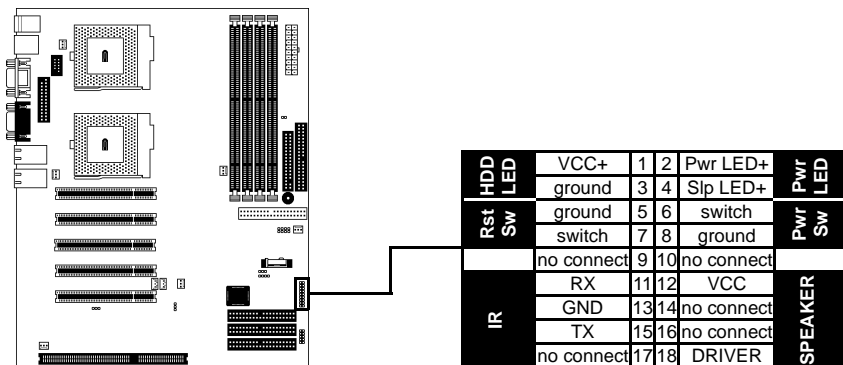

Your chassis will usually come with connectors to install onto the motherboard, such as HDD and Power LEDs. The Front Panel Connector (J12) has been implemented for such purposes.

Abbreviations	
Rst	→ Reset
Pwr	→ Power

2.6-B. CMOS Reset (JP8)

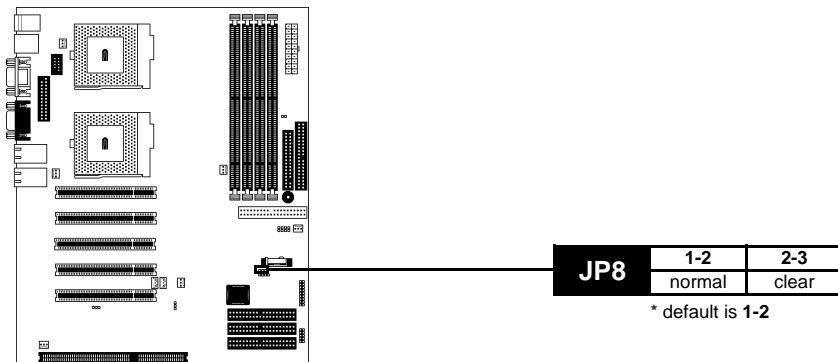

If you have been locked out of your system because you forgot your password, or set the CMOS incorrectly, or have just finished flashing your BIOS follow the instructions below.

1. Power off the system
2. Close pins 2-3 on JP8
3. Wait about three seconds
4. Close pins 1-2 on JP8, then power on the system again

By following this procedure, you will erase your password and reset the CMOS.

2.6-C. IDE RAID Enable/Disable (JP11)*

Jumper JP11 will allow you to enable or disable the (**optional**) onboard IDE RAID feature.

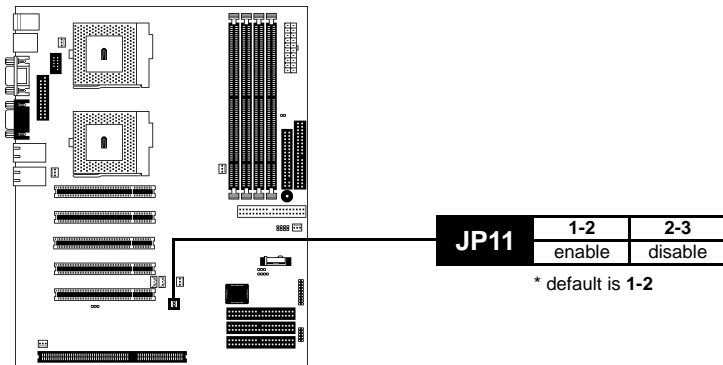

2.6-D. Onboard VGA Enable/Disable (JP10)

Jumper JP10 will allow you to enable or disable the (**optional**) onboard video features.

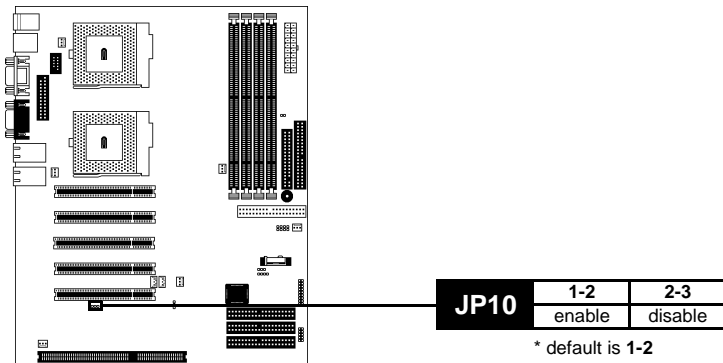

* optional feature available on some Tiger 200T models

2.6-E. FAN Connectors (FAN1, FAN2, FAN3, FAN4, FAN5, FAN6)

These FAN connectors can be used to install cooling devices. FAN1 and FAN3 are for CPU1 and CPU2, respectively.

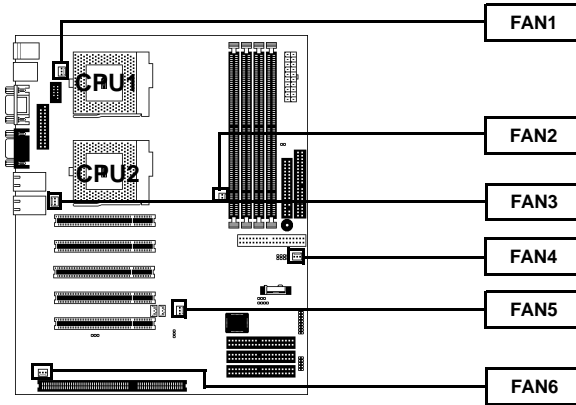

FAN	1	2	3	Specifications	
		ground	+12V	speed	Voltage
				Amperage	1.2A

NOTE:

The FAN connectors are 12V at 1.2A. Tyan takes no responsibility and will not be held liable for damage related to the misuse of these fan headers.

2.6-F. CPU Frequency Ratio Jumpers (JP4, JP5, JP6, JP7)

For non-retail/engineering sample CPUs, the frequency ratio can be adjusted. **NOTE:** Tyan takes no responsibility and will not be held liable for damage from incorrect setting of these jumpers from the CPU manufacturer's specifications.

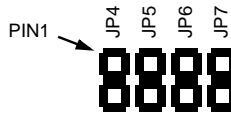
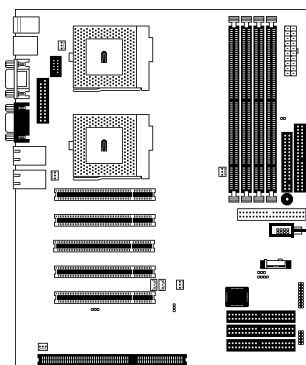

JP4, JP5, JP6, JP7						
Freq.	RATIO	JP4	JP5	JP6	JP7	
1.0GHz	133x7.5	ON	OFF	OFF	OFF	
1.33GHz	133x10.0	OFF	ON	OFF	OFF	
733MHz	133x5.5	OFF	OFF	OFF	ON	
866MHz	133x6.5	ON	ON	OFF	OFF	
1.06GHz	133x8.0	OFF	ON	ON	OFF	
1.2GHz	133x9.0	ON	OFF	OFF	ON	
933MHz	133x7.0	ON	OFF	ON	OFF	
800EBMHz	133x6.0	ON	ON	ON	OFF	
1.13GHz	133x8.5	ON	OFF	ON	OFF	
1.266GHz	133x9.5	ON	ON	OFF	OFF	
20EMHz	10x2.0	ON	ON	ON	ON	
20EMHz	10x2.0	OFF	OFF	OFF	OFF	

2.6-G. Serial Port Connector (“COM1” or Serial Port B)*

This header can be used to connect an **(optional)** serial port. More details available on the Tyan website:
<http://www.tyan.com>

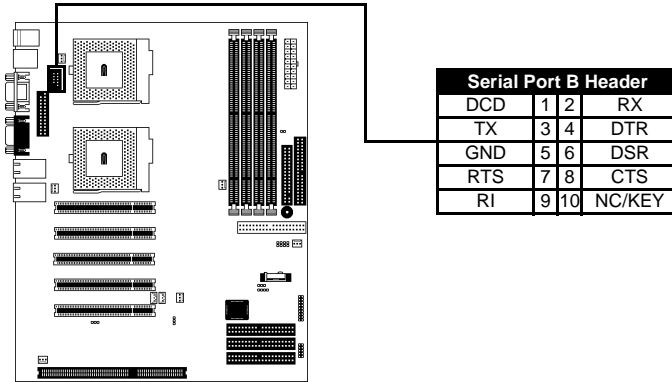

2.6-H. USB Connector (USB2)**

This header can be used to connect the **(optional)** USB cable. Pinouts for USB2 are shown below.

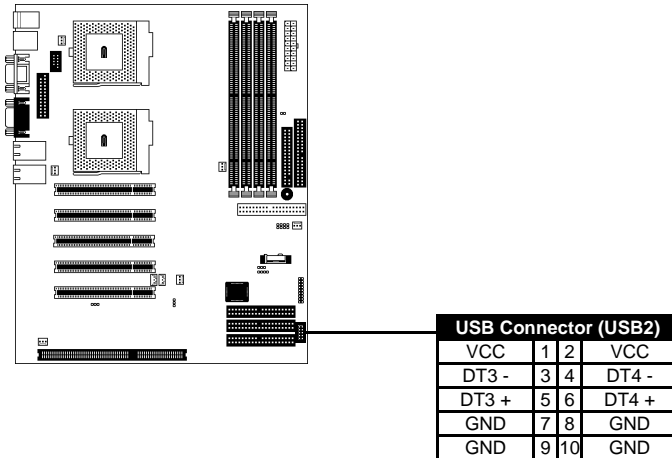

* extra accessories can be purchased at the Tyan Online Store: <http://www.etyan.com>

** if your chassis supports frontside USB cables, it will usually come with those cables. Check with your chassis vendor for details. Tyan does not provide frontside USB cables.

2.6-I. Wake-on-Ring, Wake-on-LAN (J8, J9)*

These headers can be used to connect the **(optional)** WOR and WOL devices. WOR is J8, and WOL is J9.

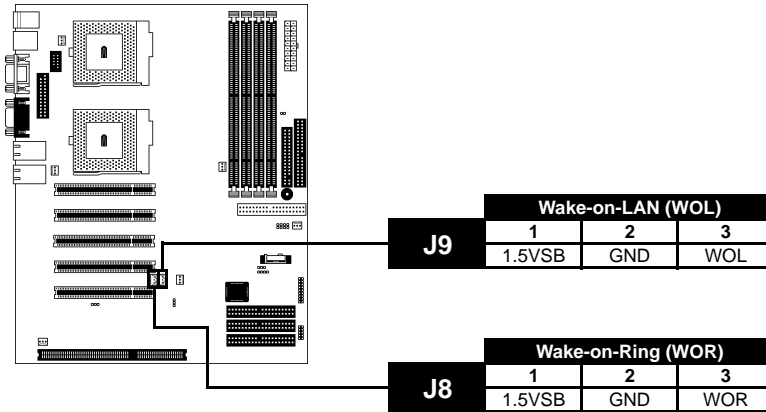

2.6-J. IDE RAID Connectors (IDE3, IDE4)*

These headers can be used to connect the **(optional)** IDE RAID devices. IDE3 is the Primary IDE RAID-connector, and IDE4 is the Secondary IDE RAID connector.

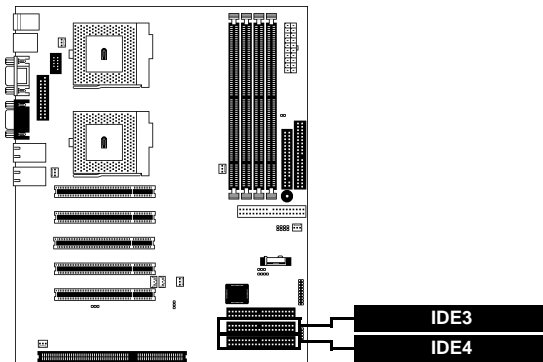

* optional feature available on some Tiger 200T models

2.6-K. Soft Power Connector Installation

The soft power connector is part of the Front Panel jumper block J12 (pins 6 and 8). This board uses the chipset for power management, including turning on and off the system. If the power button function option in the BIOS Power Management menu is set to "On/Off", pressing the power button once after the BIOS has booted up will turn the system on and off. If the power button function is set to Suspend, pressing the power button once will wake up the system or send it to Suspend mode. In this case, you cannot turn the system off unless you shut down through the Windows operating system or you hold the power button down for four seconds (BIOS-dependent feature).

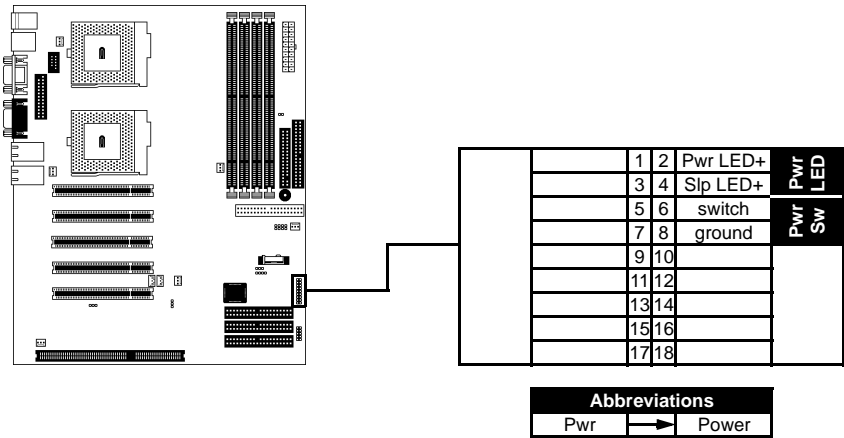

2.6-L. Hardware Reset Switch Connector Installation

The reset switch on your chassis case provides you with the Hardware Reset function, which is the same as power on/off, except that the system will immediately execute a cold start after the reset button is pushed. The reset connector is part of the Front Panel jumper block J12 (pins 5 and 7).

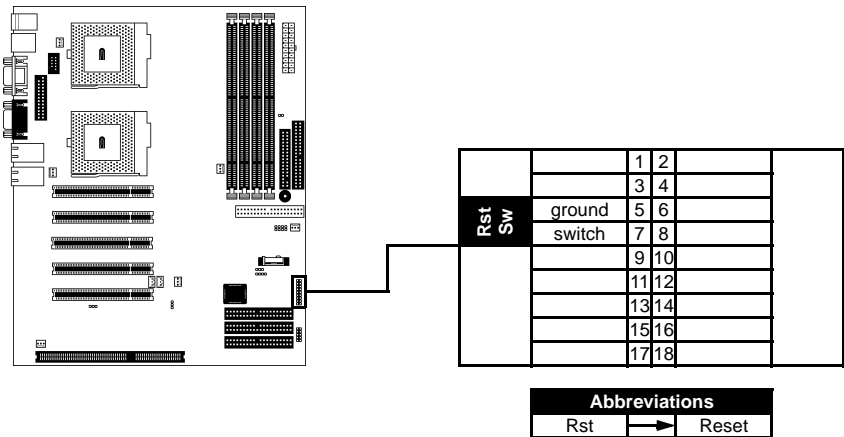

2.6-M. Flash Utility

You can upgrade the BIOS of this motherboard by using the Flash Utility. Check [p. 43](#) for details.

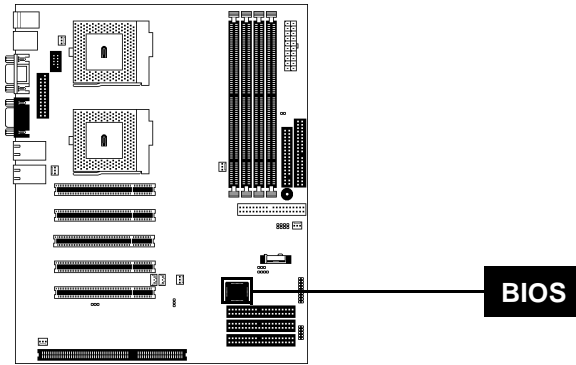

2.7 Mounting the Motherboard into the Chassis

Your chassis may include mounting hardware. If mounting hardware was included, you can use the following examples to help you in installing your motherboard into the chassis.

The chassis may have come with the studs integrated into the chassis wall, so in those cases you would only need to use screws (possibly included with your chassis) to install the motherboard. See the examples (**Figure 2.0**, shown below) for more details.

If the chassis includes mounting hardware without the studs pre-installed, then you will need to install the motherboard using the mounting hardware as shown in the examples **below**. Remember not to over-tighten any of the screws, or you might risk breaking internal traces in the surrounding area, or damage the motherboard in some other way.

Other examples of how to install your motherboard using other hardware (that may or may not have been included with your chassis) are shown below.







Type of hardware	One solution for installing motherboard	Another solution	Another solution
	 <p>screw</p> <p>motherboard base</p> <p>stud</p> <p>chassis wall</p>		
	 <p>motherboard base</p> <p>standoff</p> <p>chassis wall</p>		
	 <p>motherboard base</p> <p>standoff</p> <p>chassis wall</p>		

Figure 2.0

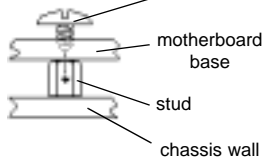

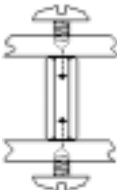

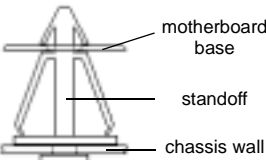
NOTE:

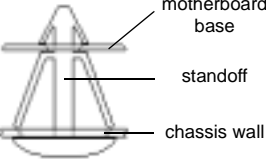
The diagrams above are only representative of a few solutions for installing a motherboard into the chassis. The installation procedure for installing your motherboard into the chassis may differ.

2.8 Installing Memory

Please keep in mind that although some memory modules may appear to be high-quality, they may contain inferior or substandard parts. The type of memory you choose to install should be checked against the memory compatibility list, which is available from Tyan's website at <http://www.tyan.com>

Here are some details of memory installation for this board:

-  At least one non-registered, unbuffered DIMM must be installed in order to POST.
-  Supports 128MB, 256MB, 512, or 1024MB* buffered or unbuffered DIMMs.
-  All memory is automatically detected, there is no need to set any jumpers.
-  The motherboard supports up to 4GB* of buffered or unbuffered PC100 or 133 SDRAM

Memory Installation Procedure

- Step 1** Line your module up so that the pins fit into the socket. There is only one way your DIMM can fit properly. Make sure that the short row of pins is lined up with the short gap in the DIMM socket, just as the long row of pins should line up with the long gap in the DIMM socket.

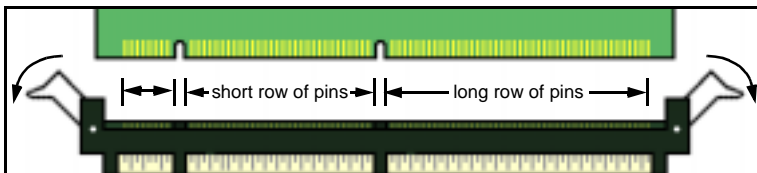

- Step 2** Insert the DIMM by pushing the module into the socket **with even force**. Do not insert one end and then the other: install the whole module at once or you might bend the DIMM pins. Make sure the DIMM is securely seated.

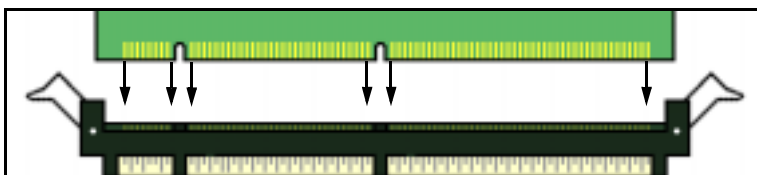

* Memory support dependent on operating system used. Check the Tyan website for updated details on memory support for the Tiger 200T: <http://www.tyan.com>

Step 3 Lock the DIMM into place by pushing the clips back on either end of the socket onto the notches in the ends of the DIMM (see pictures below for details).

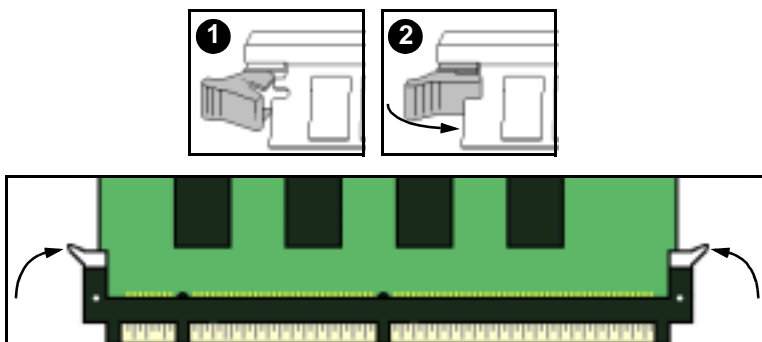

Removing a DIMM

Removing a DIMM is just the reverse: pull back the clips from the DIMM (see pictures below), and carefully pull the module straight out. Place the DIMMs in an anti-static bag as soon as you remove them to avoid static damage.

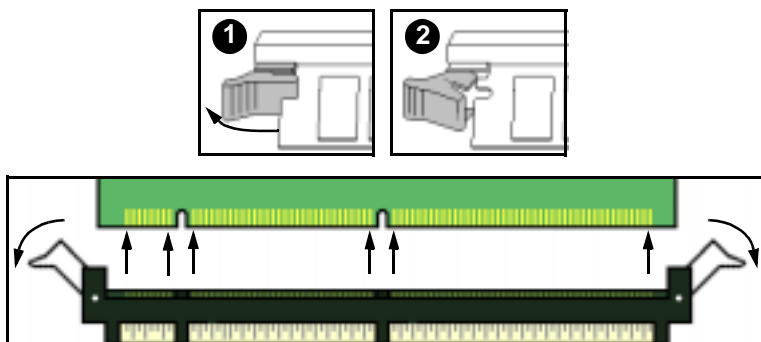

Buffered vs. Unbuffered Memory

The 168-pin DIMMs (Dual In-line Memory Modules) must be of the **3.3V PC100/PC133** variety. The notch position in the SDRAM key position will tell you whether or not a DIMM is unbuffered (see **Figure 2.1 below**). All installed memory will be auto-detected, so there is no need to set any jumpers.

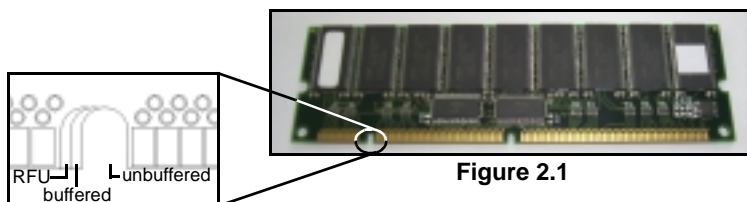

Figure 2.1

Suggested Memory Configurations

The table below shows some of the possible memory configurations. **Not all possible configurations are listed.** Your memory configuration may differ from one or more of the combinations shown below. **Please make sure that you using SDRAM DIMMs!**





Up to 4GB* at PC100 or PC133 combination							
DIMM 1	64MBx1	0	128MBx1	256MBx1	512MBx1	512MBx1	1024MBx1
DIMM 2	0	64MBx1	0	0	512MBx1	0	1024MBx1
DIMM 3	0	0	128MBx1	256MBx	0	1024MBx1	1024MBx1
DIMM 4	0	64MBx1	0	0	0	0	1024MBx1
TOTAL	64MB	128MB	256MB	512MB	1024MB	1536MB	4096MB*

* Memory support dependent on operating system used. Check the Tyan website for updated details on memory support for the Tiger 200T: <http://www.tyan.com>

2.9 Installing the CPU and Cooling Fan

Intel Pentium III processors from 1.13+GHz and Intel Celerons up to 800MHz can be used on this board. For more information on CPU compatibility, check Tyan's website at: <http://www.tyan.com>.

When installing your CPU, remember the following:

-  The CPU is a sensitive electronic component and can easily be damaged by static electricity
-  Do not touch the CPU pins with your fingers
-  You should be able to insert the CPU into the socket with virtually no force
-  Do not press down hard on the CPU as you might bend or break pins, or otherwise damage the CPU
-  The CPU voltage will automatically be detected by the motherboard, so there is no need to set any jumpers or BIOS setting.

Installing the CPU

Before installing the CPU, check it for any visible damage. Make sure none of the pins are bent or missing. Be sure where Pin 1 is on both the CPU and the socket. The following steps each have a corresponding picture next to it to help guide you through the installation.

Step 1 Carefully lift the arm of the ZIF socket until it is at a 90 degree angle pointing away from the motherboard. Be very careful not to damage any components that might be next to the socket.

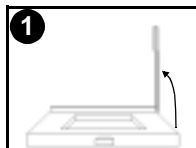

Step 2 There are two beveled corners on the CPU, which will match the two angled corners on the socket. Carefully install the CPU by lining both Pin 1 on the CPU and Pin 1 on the socket, making sure the pins actually fit into the socket. **Do not** force the CPU into the socket: check the pin alignment of CPU pins to socket holes.

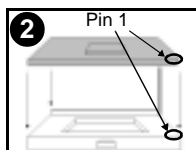

Step 3 Push down lightly on the CPU while lowering the arm on the socket to secure the CPU (see right). A squeaking noise may be heard while lowering the arm, or the socket may make a 'click' noise when the arm is locked into position: these noises are normal.

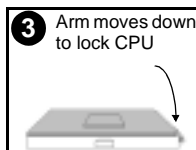

Installing the Cooling Fan(s)

After a CPU has been installed, you will need to **install the proper cooling device** for the CPU. This device, a heatsink/fan combination, can be purchased at many computer retail stores. Installation of the cooling device may vary depending on the fan manufacturer's design. You should also take space into consideration when install a cooling device: make sure the cooling device is not too big, or else you may end up damaging components around the CPU socket.

Tyan **highly recommends** that you use a thin layer of some type of thermal compound (available from many computer retail stores), between the CPU and heat sink, to maximize distribution of heat away from the CPU. Please use extra caution when installing any type of clamp-style fan, or else damage may occur to the CPU socket, and/or the CPU itself. See **the picture to the right** for an example of how to connect the cooling fan's power supply. Another diagram has also been provided below, to aid in CPU fan installation onto the socket. Check with your cooling device vendor for more details about installation.

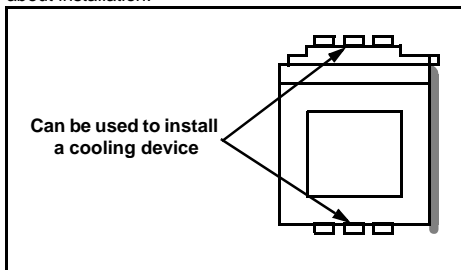

Mounting points on the CPU socket

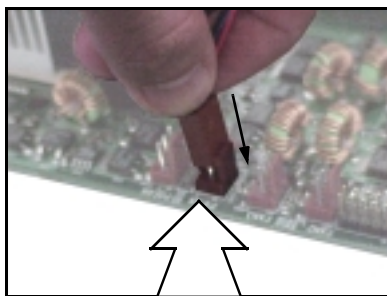

Close-up of fan connector

FAN		
1	2	3
ground	+12V	speed

Specifications	
Voltage	12V
Amperage	1.2A

NOTE:

The FAN connector has a **12V, 1.2A limitation**. Tyan takes no responsibility and will not be held liable for damage related to the misuse of any FAN jumper.

Installing Chassis Fans

Alternatively, if you wish to also install chassis fans for increased cooling, headers are provided to power those fans as well (see **p. 13, section 2.6-E**). Chassis fan installation will vary depending on your chassis manufacturer's design. Please check with your chassis manufacturer for details on proper chassis fan installation.

2.10 Connecting IDE and Floppy Drives

A variety of IDE and ATAPI-compliant devices can be installed on this motherboard, such as hard disk drives (HDDs) and CD-ROMs.

Please keep in mind that on this motherboard, the primary IDE connector is **BLACK**, and the secondary IDE connector is **WHITE**. See the picture to the right for an example of the IDE cable properly connected to the motherboard, with the **BLUE** end of the IDE cable installed on the motherboard.

Pin 1 on the IDE cable is usually denoted by a red or colored stripe down one side of the cable. That side of the cable must match Pin 1 on the motherboard's IDE connector. There will also be a key pin on the cable that matches with a notch in the IDE connector, to ensure proper installation. Consult the documentation that came with your IDE/ATAPI device, or contact the device's manufacturer for more details on installation.

Please note that UltraDMA-100/66 IDE HDDs require a special 80-wire cable which has additional grounding wires. This cable has been included with this motherboard for your convenience. The UltraDMA-100/66 cable is backwards compatible with UltraDMA-33 and legacy IDE HDDs.

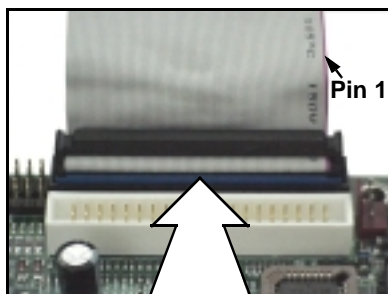

BLUE end goes to IDE connector

NOTE:

Only Tyan-approved cables are recommended for this motherboard. If you are using an existing configuration with older cables, your system might not function properly. Use only Tyan-approved cables (i.e. the ones included with your motherboard).

Some symptoms of incorrectly installed HDDs are...

HDDs are not auto-detected	May be a Master/Slave configuration problem, bad IDE cable, or BIOS mis-configuration. Consult the HDD documentation or contact your HDD vendor.
Hard Disk Drive Fail message at bootup	May be a bad cable or lack of power going to the drive. Check the cables for damage and bad connections.
No video or beeps during bootup	Usually means the cable was installed backwards.
HDD lights are constantly on	Bad IDE cable or defective drives. Try another HDD, or contact your HDD vendor.
HDD does not power on	Check power cables and cabling. May be a bad power supply or IDE drive problem.

Connecting Floppy Drives

See **the picture below** for an example of a floppy cable. Most of the current floppy drives on the market require that the cable be installed with the colored stripe positioned next to the power connector. In most cases, there will be a key pin on the cable which will force a proper connection of the cable.

The first floppy drive (sometimes denoted as A:) is usually attached to the end of the cable with the twist in it. Drive B: is usually connected to the second or third connector in the cable (the second or third connector after you install Drive A:). Refer to your floppy drive's installation instructions (if available), or contact your dealer if you are unsure about how to attach the floppy drive(s). Remember, you can only have 2 floppy drives connected at any given time.

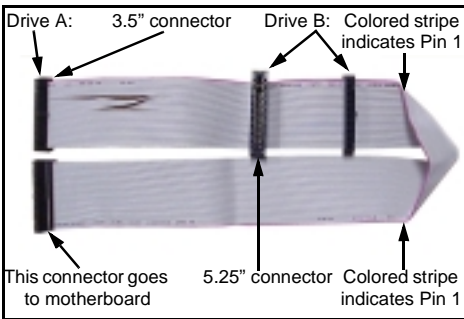
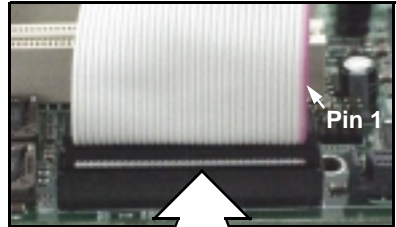

Floppy cable*

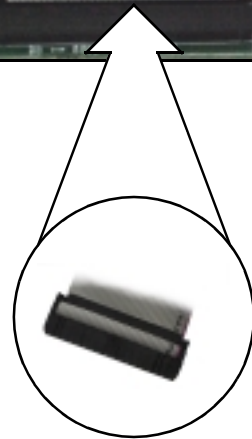

Match striped side with Pin 1

Some symptoms of incorrectly installed FDDs are...

<p>FDDs are not auto-detected</p>	<p>Usually caused by faulty cables, cables put in backwards, or a bad floppy or motherboard. Try another floppy drive to verify the problem or try another cable. Also check to see if the onboard floppy is enabled in the BIOS.</p>
<p>Floppy Drive Fail message at bootup</p>	<p>The cable or floppy drive may be faulty. Try another cable or floppy drive to verify.</p>
<p>FDD does not power on</p>	<p>Check power cables and cabling. May be a bad power supply or IDE drive problem.</p>
<p>FDD light is constantly on</p>	<p>Usually signifies that the cable is on backwards. Reverse the cable at the floppy drive end and try again.</p>

* Cable may vary. Diagram provided for reference only.

2.11 Installing Add-on Cards

There are a few rules you need to follow when installing add-on cards. In order to assure proper operation and a quick installation, adhere to the following guidelines:

- ➡ If you are going to install a PCI-bus interface card on your system, be aware that any one of the five PCI slots can support a Master or Slave device.
- ➡ NEVER force a card into a slot. If it doesn't fit, look at the socket on the motherboard to make sure there are no wires or other obstructions to the slot.
- ➡ NEVER plug an ISA card into a PCI slot. You will void your warranty and damage your system board if you do this.
- ➡ When plugging the card in, especially when installing long cards, try to push the entire card in at one time. Don't force one end of the card into the socket first and then the other, or a rocking motion between the card and the slot might occur, and could damage the pins within the socket.
- ➡ Make sure the cards are seated securely into their slots.
- ➡ Before turning on the system, make sure no cards are touching.
- ➡ Check the PCI device specifications with the PCI slot specifications (p.6) BEFORE installing!

When installing the add-on cards, make sure the cards are installed with **even** force; do not insert one end and then the other. See the before (**Figure 2.2a**) and after (**Figure 2.2b**) example installation images below for details.

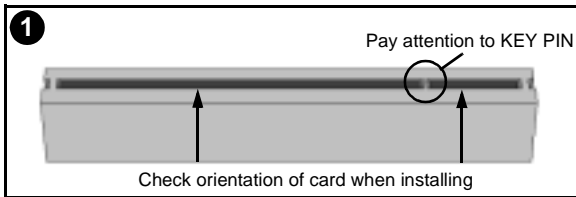

Figure 2.2a*

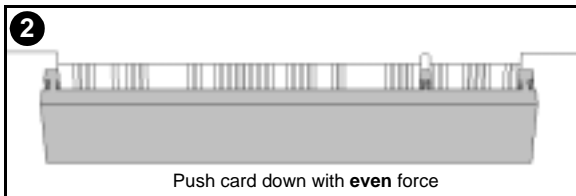

Figure 2.2b*

* The diagrams are provided as examples for installation, and may not represent the actual slots

2.12 Connecting PS/2, USB, and Serial Devices

This motherboard includes ports for PS/2 mouse and keyboard, Universal Serial Bus (USB) devices, and serial and parallel devices. Please note that the upper PS/2 port is the mouse port, and the lower PS/2 port is for the keyboard (see **Figure 2.3** below).

Installation of peripheral/external devices may vary. For details on installation of devices into the various ports shown below, please consult your device's documentation, device manufacturer, or your dealer for details.

Connecting Serial and Parallel Ports

The serial and parallel ports can be used to connect various devices such as a mouse or printer. The connectors can only be connected one way: be sure and check the orientation of the connector before installing it into the port.

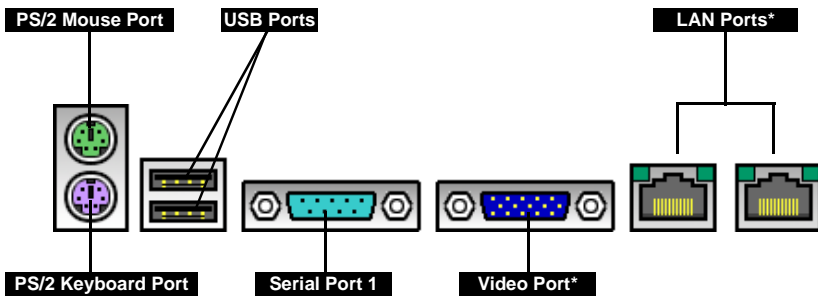

Figure 2.3

NOTE:

When plugging in your keyboard and mouse, or when plugging in anything into a serial or parallel port, make sure that the power is off. Connecting these devices and ports while the power is on is called **hot plugging** and may damage your system and/or external devices that you are trying to install.

* optional feature available on some Tiger 200T models

2.13 Connecting the power supply

This motherboard requires an **ATX power supply**, one that conforms to **ATX standard 2.01 or better**.

The clip on the power connector should lock over the tab on the onboard connector. You shouldn't be able to plug the power connector in any other way but just to be safe, make sure it looks like **Figure 2.4b**. Make certain that you do not miss connecting any of the pins because if you do, you will void your warranty and possibly cause damage to yourself and/or your motherboard when the power is turned on. After connecting the power, make sure the connector is seated firmly into its socket so it will not become loose or fall off when the computer is jostled or moved.

Step 1 Shown on the right, in **Figure 2.4a**, is the 20-pin connector of the ATX power supply.

Note the clip in the image: it will help you install the plug correctly.



Figure 2.4a*

Step 2 Shown on the right, in **Figure 2.4b**, is the 20-pin connector plugged into the board*.

The clip is over the **TAB** of the onboard connector.

As you connect the cable into the motherboard's 20-pin onboard connector, it will make a **CLICK** noise.

This is normal.

It indicates that the clip has successfully snapped over the tab.

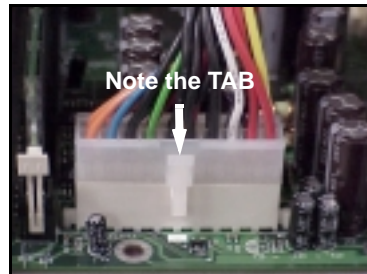

Figure 2.4b*

* The images are provided as examples for installation, and may not represent the actual board

2.14 You are done!

Other than checking the jumper settings and cable connections, and putting the case back together, you are done.

Installing a new motherboard may seem difficult, but by following these directions, you should have a fairly uneventful time installing our products. If you do encounter problems, your vendor/dealer will be able to help you, or you can consult one of our many technical support resources (see **p. 55**).

2.15 Frequently Asked Questions (FAQ)

Q: My system sometimes becomes unstable. How should I check the system?

A: The first thing to do is to check and see if you have any device conflicts related to the IRQ, or DMA. If you are using Microsoft Windows, the Control Panel is a good place to start investigating the conflict. Please consult your operating system documentation for details. Secondly, slowing down the memory timing in the BIOS chipset setup section might help the situation as well. Many memory modules are not suitable for high performance systems and might be the main source of your problem. Also check to make sure you are using a power supply that confirms to **ATX 2.01 or better**. Lastly, make sure the motherboard is receiving adequate cooling.

Q: I have a question about memory compatibility; what memory will work on my motherboard?

A: Memory compatibility information can be found on Tyan's website at: <http://www.tyan.com>

Q: Where can I get additional accessories for my Tyan motherboard?*

A: You can purchase additional accessories such as USB cables*, as well as other Tyan-approved accessories at the Tyan Computer Online Store: <http://www.etyan.com>

Q: Where do I get pinout information for my motherboard?

A: Pinouts of certain headers are available on the Tyan website: <http://www.tyan.com>

Q: My motherboard is dead, how do I return it?

A: Contact the place of purchase or your distributor for assistance to return the motherboard for service. RMA issues will not be handled via e-mail by Tyan Tech Support. Please refer to the URL link here for more details: http://www.tyan.com/support/html/faq_rma.html

Q: How do I upgrade my BIOS?

A: Check the section about the Flash Utility (see **p. 43**) for information on upgrading your BIOS. BIOS update files, flash utilities, and instructions on how to install them are also available from the Tyan website at: <http://www.tyan.com>

Q: Why do I get a "CMOS checksum invalid" error message during POST?

A: If you get the above error message or "Invalid configuration, run Setup" message, it is an indication that the CMOS battery needs to be changed. Contact your dealer for assistance. Once you've replaced your battery or flashed your BIOS, don't forget to check the Clear CMOS section (see **p.11**) so that you can reset your CMOS.

* If your chassis supports frontside USB connectors, it will usually come with the necessary cables. Check that your chassis is frontside USB capable. Please check with your chassis vendor for details. Tyan does not provide frontside USB cables.

Chapter 3: BIOS Setup

Introduction to the BIOS setup

The BIOS is the Basic Input/Output System, required by the computer to perform functions such as CPU and hard drive support. This chapter describes different settings for Award BIOS that can be used to configure your system.

The BIOS section of the manual is subject to change without notice and is provided here for reference purposes only. The settings and configurations of the BIOS are current at the time of print, and therefore they may not be exactly the same as that displayed on your screen.

The manual describes the Award BIOS setup program. The setup program lets you modify basic configuration settings. The settings are then stored in a dedicated battery-backed memory, called NVRAM, that retains the information when the power is turned off.

The Award BIOS in your computer is a customized version of an industry-standard BIOS for IBM PC AT-compatible personal computers. It supports Intel x86 and compatible processors. The BIOS provides critical low-level support for the system central processing, memory, and I/O subsystems.

The BIOS has been customized by adding important, but non-standard, features such as virus and password protection, power management, and detailed fine-tuning of the chipset controlling the system. The rest of this manual is intended to guide you through the process of configuring your system using the Award BIOS setup program.

Starting Setup

The BIOS is immediately activated when you first turn on the computer. The BIOS reads system configuration information in CMOS RAM and begins the process of checking out the system and configuring it through the Power-On Self Test (POST).

When these preliminaries are finished, the BIOS seeks an operating system on one of the data storage devices (HDD, FDD, etc.) and if one is found, the BIOS will launch that operating system and hand control of system operations to it. During POST, you can start the setup program by pressing the **[DEL]** key when the "Press DEL key to enter BIOS setup" message appears on the screen.

Setup Keys

The table below shows how to navigate in the setup program using the keyboard.

Key	Function
Arrow keys	Moves from one selection to the next
Enter	Select the highlighted option
+/-/PGUP/PGDN	Change option setting
ESC	Exit
F1	General Help
F2	Item Help
F5	Previous values
F6	Load failsafe defaults
F7	Load optimized defaults
F9	Menu in BIOS
F10	Save settings and exit

Getting Help

Press **[F1]** to display a small help window that describes the appropriate keys to use and the possible selections for the highlighted item. To exit the Help Window press **[ESC]** or the **[F1]** key again.

In Case of Problems

If you discover that you have trouble booting the computer after making and saving changes with the BIOS setup program, you can restart the computer by either:



Pressing **[CTRL]+[ALT]+[DEL]** (all three keys at the same time), or



Holding the power button down until the computer shuts off, then reset the CMOS (see **p. 11**)

The best advice is to alter only settings that you thoroughly understand. In particular, do not change settings in the Chipset screen unless you are absolutely sure that you need to. The Chipset defaults were carefully chosen for the best performance and reliability. Even a seemingly small change to the Chipset setup may cause the system to become unstable.

Setup Variations

Not all systems have the same setup program. While the basic look and function of the setup program remains more or less the same for all system, the appearance of your Setup screen may differ from other Award BIOS screens. Each system design and chipset combination require custom configurations. In addition, the final appearance of the setup program depends on your system designer. Your system designer can decide that certain items should not be available for user configuration, and remove them from the BIOS setup program.

General Help

At any time, you can press **[F1]** to bring up a General Help screen in case you want to learn the shortcut commands. There are two settings you should be aware of (listed below).

Setting	Function
Load Failsafe Defaults	If your system is experiencing configuration problems, you can choose this option to reset all settings.
Load Optimal Defaults	This will load preset options that are designed for maximum system performance, but may not work for all computer applications. You should not use this option if you are experiencing configuration problems.

3.1 Main Setup

The BIOS allows you to select from several setup functions and two exit choices. If an additional configuration screen is available, it will have a **▶** symbol. If you select that option with that symbol, you will be brought to another configuration screen. Hitting **[ESC]** will bring you back out.

3.2 Standard CMOS Setup

3.2-A. Date/Time

You can type in the date and time directly, or select the portion of the date or time that you want to modify and adjust it using the **↑ ↓** cursor keys. The clock runs on a 24-hour cycle (i.e 1:00 PM is 13:00).

3.2-B. IDE Primary/Secondary Master/Slave

These four options are for setting IDE devices such as HDDs and CD-ROMs. If left on the default setting of "Auto", the drives will be auto-detected.

The next page describes the settings available for configuring the IDE devices.

3.2-C. Table of IDE device settings

Type	The type of IDE device installed can be configured using this option. [Default setting is Auto for auto-detect]
LBA/Large Mode	These modules make it possible for the BIOS to take advantage of the additional space on drives which are larger than 504MB. This can be auto-detected (when you select Auto for Type), or you can manually set this mode to Disabled. [Default setting is Auto]
Block (Multi-sector Transfer)	When set to Auto, the block mode auto-detects the optimal number of block read/writes per section that the drive supports. [Default is 0]
PIO Mode	Programming input/output is a method of transmitting data between devices that use the system's CPU as part of the data path. There are 6 modes: 5 with their own transmission speed and 1 auto mode. To use modes 3 and 4, you must use an Enhanced IDE drive. [Default is Auto]
Access Mode	This option specifies the Direct Memory Access mode for the IDE device. If set to Auto, the BIOS will determine the DMA mode. [Default is Auto]

The following settings are also available in the Standard CMOS Setup screen.

Drive A	The settings are 360KB 5.25", 1.2MB 5.25", 720KB 3.5", 1.44MB 3.5", or 2.88MB 3.5". [Default is 1.44, 3.5"]
Drive B	The options are the same as listed for Floppy A. [Default setting is Disabled]
Floppy 3 Mode	Sets whether you have a Japanese standard mode floppy (1.2MB storage on 3.5" drive). [Default is Disabled]
Video	Sets the video display mode at boot-up time. [Default is EGA/ VGA]
Halt On	The system will halt on errors at boot-up time, depending on what option is set here. [Default is All, But Keyboard]

3.2-D. Memory

You cannot change any values in the Memory fields, as they are shown only for your information. The fields show the total installed random access memory (RAM) and amounts allocated to base, extended, and other memory. RAM is the computer's working memory, where the computer stores programs and data currently being used, so that they are accessible to the CPU. RAM is counted in kilobytes (KB: approximately one thousand bytes) and megabytes (MB: approximately one million bytes). Modern personal computers may contain up to 128, 256 MB, or more.

Base Memory	Typically 640KB. Also called conventional memory. The DOS operating system and conventional applications use this area.
Extended Memory	Above the 1MB boundary. Early IBM personal computers could not use memory above 1MB, but current PCs and their software can use extended memory.
Other Memory	Between 640KB and 1MB; often called high memory. DOS may load terminate-and-stay (TSR) programs in this area, such as device drivers, to free as much conventional memory as possible for applications. Lines in your config.sys file that start with loadhigh , load programs into high memory, for example.

3.3 Advanced BIOS Features

This section may allow the user to alter certain settings that affect the way their computer boots up, checks CPU cache, and other advanced features. **Please note that you should not alter settings in this BIOS section unless you are absolutely sure that you know what you are doing.**

Virus Warning	Sets whether the BIOS should try to auto-detect for boot viruses, etc. [Default setting is Disabled]
CPU Internal Cache	Sets whether or not your installed CPU has internal cache [Default setting is Enabled]
External Cache	Sets whether or not external cache is installed. [Default is Enabled]
CPU L2 Cache ECC Checking	Sets whether the CPU's L2 (Level 2) cache has ECC checking. [Default is Enabled]
Processor Number	Shows the ID number for the processor used. [Default is Enabled]
Quick Power On Self Test	Sets whether BIOS should perform the quick POST during boot-up. [Default is Disabled]
First Boot Device	Sets the first device that the BIOS should check in order to boot-up. [Default is Floppy]
Second Boot Device	Sets the second device that the BIOS should check in order to boot-up. [Default is CD-ROM]
Third Boot Device	Sets the third device that the BIOS should check in order to boot-up. [Default is HDD-0]
Boot Other Device	Sets whether still another boot device should be checked. [Default is Enabled]

(continued on next page)

(continued from previous page)

Swap Floppy Drive	If you have two drives and need to swap them for some reason, use this option. [Default setting is Disabled]
Boot Up Floppy Seek	Sets whether the BIOS should check all floppy drives during boot-up. [Default setting is Enabled]
Boot Up Numlock Status	Sets whether the Num Lock key should be enabled during boot-up. [Default is Enabled]
Gate A20 Option	Refers to the method that the system addresses memory above 1MB. [Default is Normal]
Typematic Rate Setting	Sets whether the keyboard input speed should be altered. [Default is Disabled]
Typematic Rate	If above setting is Enabled, this sets the characters per second of keyboard input. [Default is 6]
Typematic Delay	If above setting is Enabled, this sets the delay on character input from keyboard. [Default is 250]
Security Option	Sets whether the password should be enabled. [Default is Setup]
MPS Version Control for OS	Reserved function related to multi-processing capability. Options are MPS 1.1 or MPS 1.4. [Default is 1.1]
OS Select for DRAM > 64MB	If your OS requires this setting, it can be altered from here. [Default is Non-OS2]
HDD S.M.A.R.T. Mode	Allows the S.M.A.R.T. protocol to report server system information over a network. [Default is Auto]
Report no FDD	Allows the BIOS to report to Win95 that no FDD exists (if this is the case). [Default is No]
Video BIOS Shadow	Reserved. [Default is Enabled]
C800-CBFFF Shadow to DC000-DFFFF Shadow	Reserved. [Default is Enabled]
Small Logo (EPA) Show	Provides the options for the EPA logo, on whether it should be shown or not. [Default is Disabled]

3.4 Advanced Chipset Features

This section describes the settings for the chipset installed on this motherboard. **Please note that the parameters described in this section are for technically competent users only. Do not change these values unless you completely understand the consequences of your changes.**

Bank 0/1 to Bank 6/7 DRAM Timing	Settings depend on type of memory installed. These settings are reserved. [Default settings are 8/10ns]
DRAM Clock	DRAM Clock cycle timing. [Default is HOST-CLK]
SDRAM Cycle Length	Sets the CAS latency timing. [Default setting is 3]
DRAM Drive Strength	Drive strength, reserved function. [Default setting is Auto]
DRAM Drive Value	Drive value, reserved function. [Default setting is 47]
Bank Interleave	Allows for memory bank interleaving. [Default is Disabled]
Memory Hole	Specifies the location of an area of memory that cannot be addressed on the ISA bus. [Default is Disabled]
P2C/C2P Concurrency	If Enabled, the PCI/AGP Master to CPU cycle can be concurrent if the Host CPU is performing R/W access to the PCI or slave devices. [Default is Enabled]
System Bios Cacheable	Sets ability to cache system BIOS ROM at F0000h-FFFFFh. [Default is Disabled]
AGP Fast Write	Setting is dependent on AGP card. [Default is Disabled]
OnChip USB	Sets whether you have USB devices. [Default is Enabled]
USB Keyboard Support	Enable or disable use of a USB keyboard. [Default is Disabled]
CPU to PCI Write Buffer	Setting this can compensate for speed differences between the CPU and PCI bus. [Default is Enabled]
PCI Dynamic Buffering	If Enabled, every write transaction goes to write buffer. Burstable transactions then burst on the PCI bus, but non-burstable transactions do not. [Default is Enabled]
PCI Master 0 WS Write	Sets whether writes to PCI bus are executed with zero wait states. [Default settings are Enabled]
PCI Delay Transaction	Sets write buffer support in compliance with PCI spec v2.1. [Default setting is Enabled]
PCI#2 Access #1 Retry	Sets whether PCI masters should rotate priority [Default is Disabled]
Memory Parity / ECC Check	Sets whether the BIOS should enable memory checking automatically when it detects ECC DRAM. [Default is Disabled]

3.5 Integrated Peripherals

This section describes settings for the integrated peripherals setup options.

On-Chip IDE Channel 0 / 1	Sets the onboard support for the two IDE channels. [Default setting is Enabled]
IDE Prefetch Mode	Sets support for IDE prefetching for faster drive accesses. [Default setting is Enabled]
IDE Pri/Sec Master/Slave PIO	Sets PIO mode for each of up to four IDE devices that the onboard IDE interface supports. [Default is Auto]
IDE Pri/Sec Master/Slave UDMA	Sets whether UDMA data transfer protocol should transfer at optimal speed, or to auto-detect optimal speed. [Default is Auto]
Init Display First	Sets type of display adapter installed. [Default is PCI Slot]
IDE HDD Block Mode	Sets onboard detection of optimal number of block R/W's per sector that the drive can support. [Default is Enabled]
Onboard FDD Controller	Sets whether onboard floppy controller should be used. [Default is Enabled]
Onboard Serial Port 1 / 2	Sets logical COM port address and corresponding interrupt for 1st and 2nd serial ports. IR is offered on 2nd port. [Default is Auto]
UART2 Duplex Mode	Sets whether COM port should be able to receive and transmit data simultaneously. [Default is Half , as in Half-Duplex]
IR Function*	Option for IR mode setting (optional). [Default is No, Yes]
Tx,Rx Inverting Enabled*	Reserved (optional). [Default is No, Yes]
Onboard Parallel Port	Sets logical LPT port address and corresponding interrupt. [Default setting is 378/IRQ7]
Onboard Parallel Mode	Sets mode for onboard parallel port. [Default setting is Normal]
ECP Mode Use DMA	Sets whether parallel port should use DMA for faster transfer rate. [Default is 3]
Parallel Port EPP Type	Sets parallel port data transfer mode. [Default is EPP1.9]

(continued on next page)

* optional feature available on some Tiger 200T models

3.6 Power Management Setup

This section describes the different power management functions that may be available on your system. Please note that power management functions are also dependent on your OS' power management functions, and that both OS and system power management functions should be set up to work in conjunction with one another.

ACPI Function	Enable or Disable Advanced Configuration Power Interface. [Default setting is Enabled]
Power Management (subscreen)	Lets you enter the screen for configuring power states.
Power Management	Sets whether each mode should be set separately. [Default is User Define]
HDD Power Down	Sets time that system should wait before powering down the HDD(s). [Default is Disable]
Doze Mode	Sets time that system should wait before CPU clock runs at slower speed to save power. [Default is Disabled]
Suspend Mode	Sets time that system should wait before suspending all devices except for CPU, to save power. [Default is Disabled]
ACPI Suspend Type	Sets type of suspend function to enable once the system enters suspend mode. [Default is S1(POS)]
PM Control by APM	Reserved. [Default is Yes]
Video Off Option	Sets power-saving mode for video display. [Default is Suspend->Off]
Video Off Method	Determines manner in which the monitor is blanked. [Default is V/H SYNC+Blank]
Modem Use IRQ	If Modem Ring Resume is Enabled, it's possible to wake the system up by dialing into it. [Default is 3]
Soft-Off by PWRBTN	Sets time needed to hold down the power button to shutdown the system. [Default setting is Instant-Off]
State after power failure	Sets system state after a power failure occurs. [Default is Auto]
CPU Fan in Suspend	Sets state of the CPU Fan when Suspend mode occurs. [Default is Off]
Wake Up Events (subscreen)	Lets you enter the screen for configuring wake up events.

(continued on next page)

(continued from previous page)

VGA	Sets video activity as power management event. [Default is Off]
LPT & COM	Sets LPT and COM/Serial Port activity as power management events. [Default is LPT/COM]
PCI Master	Sets PCI activity as power management events. [Default is Off]
PowerOn by PCI Card	Sets Power On capability through PCI card activity. [Default is Disabled]
Modem Ring Resume	Sets Wake Up on Ring as a power management event. [Default is Disabled]
RTC Alarm Resume	Sets RTC Alarm as a power management event. [Default is Disabled]
Date / ResumeTime	Sets Date or Resume Time that system will wake up. [Default is 0]
Primary INTR	Sets whether IRQ activity should be a power management event. [Default is ON]
IRQs Activity Monitoring (subscreen)	In this screen, you can assign how power management will monitor each IRQ.

3.7 PnP/PCI Configuration

This section describes the PCI/PnP configuration options available.

PNP OS Installed	Sets whether the system is using a Plug-n-Play OS. [Default setting is NO]
Reset Configuration Data	Sets whether the configuration data in the ESCD should be reset at bootup. [Default setting is Disabled]
Resources Controlled By (ESCD)	Sets how the PnP devices will be controlled. [Default is Auto(ESCD)]
IRQ Resources	Sets IRQs PnP control statuses.
DMA Resources	Sets DMAs PnP control statuses.
PCI/VGA Palette Snoop	Reserved. [Default setting is Disabled]
Assign IRQ for VGA	Sets whether an IRQ should be reserved for VGA. [Default setting is Enabled]
Assign IRQ for USB	Sets whether an IRQ should be reserved for USB. [Default setting is Enabled]

3.8 PC Health Status*

This section describes the hardware monitoring of certain onboard devices. No options are user-defined.

Current CPU1 Temp.	Displays temperature of CPU1 in Celsius and Fahrenheit.
Current CPU2 Temp.	Displays temperature of CPU2 in Celsius and Fahrenheit.
Current CPUFAN1 Speed	Displays speed of CPUFAN1 in revolutions per minute (RPM).
Current CPUFAN2 Speed	Displays speed of CPUFAN2 in revolutions per minute (RPM).
CPU1 Vcore	Displays core voltage of CPU1.
CPU2 Vcore	Displays core voltage of CPU2.
3.3V	Displays power supply voltage on 3.3V line.
5V	Displays power supply voltage on 5V line.
12V	Displays power supply voltage on 12V line.

3.9 Frequency/Voltage Control

This section describes the processor configuration options available. **Tyan takes no responsibility and will not be held liable for damage related to misuse of these settings.**

Auto Detect DIMM/PCI CLK

Auto Detect the DIMM and PCI clock settings.
[Default setting is **Enabled**]

3.10 Set Supervisor Password / Set User Password

Both of these functions allow for passwords to be set accordingly for BIOS configuration.

When selecting one of the password functions, the following words will appear:

ENTER PASSWORD:

After typing in a new password of up to eight characters, press **[Enter]**. The following words will then appear:

CONFIRM PASSWORD:

Type your new password again, and the password will then be set. Please note that entering a new password and then confirming it, will clear any old password that you had (depending on type of password).

3.11 Exit BIOS Setup

You have the ability to perform the following options, either during setup or upon leaving setup.

Load Failsafe Defaults: loads the minimal settings for all devices for maximum safety

Load Optimal Defaults: loads the maximum settings for all devices

Save & Exit Setup: saves all changes, exits and reboots system

Exit Without Saving: discards all changes, exits and reboots system

* optional feature available on some Tiger 200T models

Chapter 4: System Resources

Note: If you experience problems with setting up your system, always check the following things in the following order:

MEMORY, VIDEO, CPU

By checking these items, you will most likely find out what the problem might have been when setting up your system. For more information on troubleshooting, check the Tyan website at <http://www.tyan.com>

4.1 Beep Codes

Fatal errors, which halt the boot process, are communicated through a series of audible beeps. For example, if the Phoenix BIOS POST can initialize the video but an error occurs, an error message will be displayed. If it cannot display video, it will convey a series of beeps.

If you hear one long beep followed by two short beeps, then a video problem has probably occurred and the BIOS is having difficulty initializing the video display. Any other beep sequences that may or may not occur are probably due to memory problems.

4.2 Flash Utility

Every BIOS file is unique for the motherboard it was designed for. Always check to see if you have the newest BIOS available for your motherboard. For Flash Utilities, the newest BIOS downloads, and information on how to properly use the Flash Utility with your motherboard, you must check the Tyan website: <http://www.tyan.com>

NOTE:

Please be aware that by flashing your BIOS, you agree that in the event of a BIOS flash failure, you must contact your dealer for a replacement BIOS. There are no exceptions. Tyan does not have a policy of replacing BIOS chips directly with end users. In no event will Tyan be held responsible for damage done to the BIOS by the end user.

Appendix I: RAID Installation (optional)

Introduction to the Promise FastTrak100 IDE RAID Controller

The FastTrak100 can stripe multiple UltraDMA/100 hard drives together under RAID 0; mirror the data on two drives under RAID 1 (master only); or do both for maximum speed and protection under RAID 0+1. Under mirroring, should one drive fail, the remaining drive will handle all data. When a new replacement drive is later installed, the FastTrak100 rebuilds data to the new drive from the mirrored drive to restore fault tolerance. Up to 4 drives* can be linked to the Promise FastTrak100 RAID controller, effectively doubling their sustained data transfer rate**. The FastBuild™ auto-menu allows for quick and easy array builds. **NOTE: You cannot install any devices other than HDDs on the RAID IDE channels!**

Features of the Promise FastTrak100 IDE RAID Controller

Drive Support	EIDE, UltraDMA-33/66/100 drives
Drives Required	2 (maximum 4)*
Data performance (RAID 0)	Doubles sustained transfers of attached drives**
Data Storage (RAID 0, JBOD)	Links multiple drives as one large drive (C, D, or other)
Data Protection (RAID 1, RAID 0+1)	Send identical data to two drives (or drive pairs) per save; rebuilds data in background; supports "hot" spare drive (RAID 1 mode only) in case of failure
Onboard BIOS support	Automatically identifies type of drive; allows booting from any drive array
RAID Levels	RAID 0 (striping 2-to-4 drives) RAID 1 (mirroring 2 drives) RAID 1 + spare (3 drives) RAID 0+1 (4 drives only) JBOD (spanning 2-to-4 drives)

Visual concepts of RAID 0 (striping) and RAID 1 (mirroring)

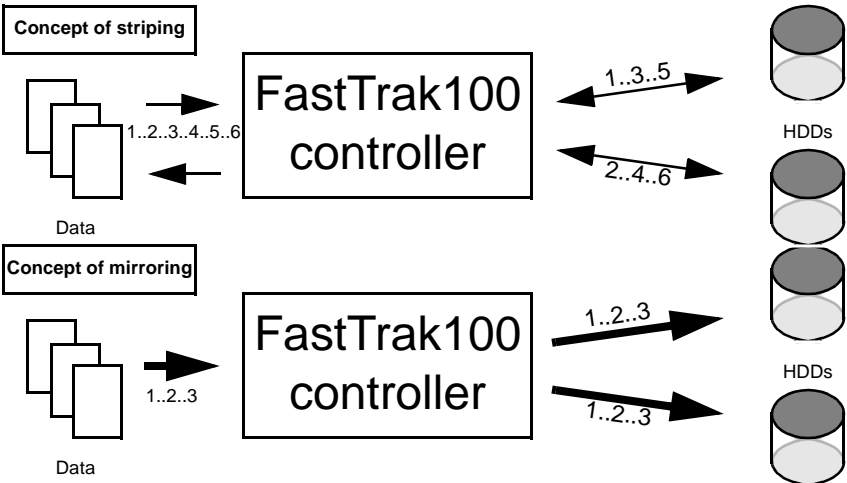

* Promise recommends using identical drives

** performance varies depending on drives and systems

Installing the hard drives

If you wish to use your current bootable HDD (using Windows NT 4.x or 2000) as part of the bootable mirrored (RAID 1) array, do **NOT** connect the hard drive yet. First, you **MUST** install Windows NT 4.x or 2000 on your **existing** hard drive controller.

Hard drives must be of the Fast ATA-2, EIDE, or UltraDMA-33/66/100 type if you want to use them with the RAID controller. For best performance, we recommend that you use drives of identical model and capacity. By matching drives, you ensure compatibility as well. If you are planning to use an UDMA-66 or 100 drive, you must use an UltraDMA-66/100 cable (Tyan has included that cable with the motherboard).

Also, if you are planning to use striping (RAID 0), we recommend you use two new drives. For mirroring (RAID 1), you should either use two new drives, or your old drive **and** a new drive (of the same size or larger than your current drive).

Step **1** The first step is to set the hard drive to either Master, Slave, or Cable Select setting, and install them according to the table below. **Note: Sometimes the Master drive with no Slave attached is called "single".** The Master/Slave setting differentiates two drives connected on the same cable. **NOTE: Check your HDD documentation for master, slave, and cable select settings.**

Jumper Settings (see your HDD documentation for jumpers)		
# of Drives	IDE Channel 1	IDE Channel 2
1	M	---
2	M	M
3	M & S	M
4	M & S	M & S

M = Master, S = Slave

Step **2** Next, you should install the drives into your system, and connect the power. Attach one UltraDMA cable (black connector) to each drive (if you have a Slave drive, connect that drive to the second connector (grey connector) on the UltraDMA cable). Make sure that Pin 1 on the cable (indicated by the colored stripe) is connected to Pin 1 of the hard drive. See **Figure I-1** (to the right) for an example.

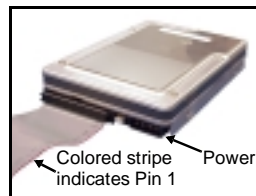

Figure I-1

Step **3** The **blue** end of the cable (see **Figure I-2** to the right for an example) goes to the RAID connector on the motherboard (see **p. 10** for location). Make sure Pin 1 of the ATA-66 cable connects to Pin 1 of the Promise RAID IDE connector (see **p. 10** for location). Check all connections after completing this step, before you continue to the next part of the installation.

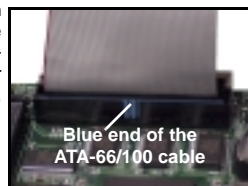

Figure I-2

NOTE:

If you are planning to use your old hard drive, backup all necessary data first. Always backup the data on an existing hard drive if you are planning to use it in a new system configuration.

Checking CMOS Settings

The FastTrak100 controller is a Plug-n-Play device that supports PCI IRQ sharing. In order to make the RAID array bootable, make sure that in the CMOS, drive types are set to "Unknown" or "Not Installed" (see p. 33, section 3.2-B). You should also change the order of boot devices (see p. 35, section 3.3) so that the FastTrak100 RAID array is the second choice as a bootable device.

Creating your disk array

You can now use the FastBuild BIOS Utility to create your drive array. Three possibilities exist: you can create an array for performance; you can create a Security array with new hard drives (recommended); or you can create a Security array using your old hard drive and a new one.

NOTE:

If you are planning to use your old hard drive, backup all necessary data first. Always backup the data on an existing hard drive if you are planning to use it in a new system configuration.

Step **1** Boot your system. If this is the first time you have booted with the FastTrak100 with drives installed, the Promise onboard BIOS will display the following screen.

FastTrak100 (tm) BIOS Version 1.xx (Build xxxx)
(c) 1995-2000 Promise Technology, Inc. All Rights Reserved.

No array defined . . .

Press <Ctrl-F> to enter FastBuild (tm) Utility
Or press <ESC> key to continue booting the system.

Step **2** Press <Ctrl-F> keys to display the FastBuild (tm) Utility Main Menu

Step **3** Press "1" to display the Auto Setup Menu (shown below). This is the fastest and easiest method to creating your first array.

FastBuild (tm) Utility 1.xx (c) 1995-2000 Promise Technology, Inc.
[Auto Setup Options Menu]

Optimize Array for: Performance
Typical Application usage: A/V Editing

[Auto Setup Configuration]

Mode.....Stripe
Drives used in Array.....2
Array Disk Capacity.....16126

[↑] Up [↓] Down [←] [→] , Space] Change Option [ESC] Exit [Ctrl-Y] Save

Creating an array for Performance (RAID 0)

FastTrak100 allows users to create striped arrays with 1, 2, 3, or 4 drives. To create your array, follow the steps outlined below.

- Step **1** Choose **Performance** under the **Optimize Array** section.
- Step **2** Select how you will use your PC the mode under the **Typical Application usage** section. The choices are **A/V Editing**, **Server**, and **Desktop** (the default).
- Step **3** Press **<Ctrl-Y>** keys to Save and create the array.
- Step **4** Reboot the system.
- Step **5** Proceed to install the drivers from the driver disk.

Creating a Security Array with New Drives (RAID 1)

To create an array for data protection using new hard drives, use the following steps.

NOTE:

FastTrak100 permits only two drives to be used for a single Mirrored array in Auto Setup. If a third drive is attached, it becomes a "hot" spare drive. If four drives are attached, the Mirroring option will not be available at all.

- Step **1** Choose **Security** under the **Optimize Array for** section.
- Step **2** Press **<Ctrl-Y>** keys to Save your selection.
- Step **3** The window below will appear.

Do you want the disk image to be duplicated to another? (Yes/No)
Y - Create and Duplicate
N - Create Only

- Step **4** Press "N" for the **Create Only** option.
- Step **5** A window will appear almost immediately confirming that your Security array has been created. Press any key to reboot the system.

Array has been created.
<Press Any Key to Reboot>

- Step **6** Once the arrayed drives have been formatted, proceed to install your O/S and drivers from the driver disk.

Creating a Security Array with an Existing Data Drive

You would use this method if you wish to use a drive that already contains data and/or is the bootable system drive in your system. You will need another drive of identical or larger storage capacity.

NOTE:

FastTrak100 permits only two drives to be used for a single Mirrored array in Auto Setup. If a third drive is attached, it becomes a "hot" spare drive. If four drives are attached, the Mirroring option will not be available at all.

NOTE:

If you are planning to use your old hard drive, backup all necessary data first. Always backup the data on an existing hard drive if you are planning to use it in a new system configuration.

NOTE:

If you wish to include your current bootable drive using the Windows NT 4.x or Windows 2000 operating system as part of the bootable Mirrored (RAID 1) array on your FastTrak100 do **NOT** connect the hard drive to the FastTrak100 connector yet. You **MUST** install the Windows NT 4.x or 2000 driver software first (from the driver disk) while it is still attached to your existing hard drive controller. For all other operating systems, continue using the following steps listed below.

Step **1** Choose **Security** under the **Optimize Array for** section.

Step **2** Press **<Ctrl-Y>** keys to Save your selection. The window below will appear.

Do you want the disk image to be duplicated to another? (Yes/No)
Y - Create and Duplicate
N - Create Only

Step **3** Press "Y" for the **Create and Duplicate** option. The window below will appear asking you to select the Source drive to use. FastBuild will copy all data from the Source drive to the Target drive.

Channel:ID	Source Disk Drive Model	Capacity (MB)
Channel:ID	Target Disk Drive Model	Capacity (MB)
[Please Select a Source Disk]		
Channel:ID	Drive Model	Capacity (MB)
1 : Master	QUANTUMCR8.4A	8063
2 : Master	QUANTUMCR8.4A	8063

[↑] Up [↓] Down [ESC] Exit [Ctrl-Y] Save

Step **4** Use the arrow keys to choose which drive contains the existing data to be copied.

Step **5** Press **<Ctrl-Y>** keys to Save selection and start duplication. The following progress screen will appear.

Start to duplicate the image . . .
Do you want to continue? (Yes/No)
Y - Continue N - Abort

Step **6** Select "Y" to continue. If you choose "N", you will be returned to Step 1.

Step **7** Once complete, the following screen will appear confirming that your Security array has been created. Press any key to reboot the system.

Array has been created.
<Press Any Key to Reboot>

Step **8** Proceed to install the drivers from the driver disk and/or the O/S.

Using FastBuild™ Configuration Utility

The FastBuild Configuration Utility offers several menu choices to create and manage the drive array on the Promise FastTRak100 Adapter. For purposes of this section, it is assumed that you have already created an array using one of the methods previously discussed, and that you wish to make a change to the array.

Viewing FastTrak100 BIOS Screen

When you boot your system with the FastTrak100 card and drives installed, the Promise onboard BIOS will detect the drives attached. If an array already exists, the following screen will be displayed:

FastTrak100 (tm) BIOS Version 1.xx (Build xxxx)
(c) 1995-2000 Promise Technology, Inc. All Rights Reserved.

ID	MODE	SIZE	TRACK-MAPPING	STATUS
1 *	2+0 Striped	16126M	611/128/32	Functional

Press <Ctrl-F> to enter FastBuild (tm) Utility....

Three possible conditions will be displayed under 'STATUS':

Functional - The array is operational

Critical - A mirrored array contains a drive that has failed or disconnected. The remaining drive member in the array is functional. However, the array has temporarily lost its ability to provide fault tolerance. The user should identify the failed drive through the FastBuild Setup Utility, and then replace the problem drive.

Offline - A mirrored array has 2 drives that have failed/disconnected or a striped array has 12 drive that has failed or been disconnected. When the array condition is "offline", the user must replace the failed drive(s), then restore the data from a backup source.

Appendix II: Glossary

ACPI (Advanced Configuration and Power Interface): a power management specification that allows the operating system to control the amount of power distributed to the computer's devices. Devices not in use can be turned off, reducing unnecessary power expenditure.

AGP (Accelerated Graphics Port): a PCI-based interface which was designed specifically for demands of 3D graphics applications. The 32-bit AGP channel directly links the graphics controller to the main memory. While the channel runs at only 66 MHz, it supports data transmission during both the rising and falling ends of the clock cycle, yielding an effective speed of 133 MHz.

ATAPI (AT Attachment Packet Interface): also known as IDE or ATA; a drive implementation that includes the disk controller on the device itself. It allows CD-ROMs and tape drives to be configured as master or slave devices, just like HDDs.

ATX: the form factor designed to replace the AT form factor. It improves on the AT design by rotating the board 90 degrees, so that the IDE connectors are closer to the drive bays, and the CPU is closer to the power supply and cooling fan. The keyboard, mouse, USB, serial, and parallel ports are built-in.

Bandwidth: refers to carrying capacity. The greater the bandwidth, the more data the bus, phone line, or other electrical path, can carry. Greater bandwidth, then, also results in greater speed.

BBS (BIOS Boot Specification): is a feature within the BIOS that creates, prioritizes, and maintains a list of all Initial Program Load (IPL) devices, and then stores that list in NVRAM. IPL devices have the ability to load and execute an OS, as well as provide the ability to return to the BIOS if the OS load process fails for some reason. At that point, the next IPL device is called upon to attempt loading of the OS.

BIOS (Basic Input/Output System): the program that resides in the ROM chip, and provides the basic instructions for controlling your computer's hardware. Both the operating system and application software use BIOS routines to ensure compatibility.

Buffer: a portion of RAM which is used to temporarily store data, usually from an application, though it is also used when printing, and in most keyboard drivers. The CPU can manipulate data in a buffer before copying it, all at once, to a disk drive. While this improves system performance --- reading to or writing from a disk drive a single time is much faster than doing so repeatedly --- there is also the possibility of losing your data should the system crash. Information stored in a buffer is temporarily stored, not permanently saved.

Bus: a data pathway. The term is used especially to refer to the connection between the processor and system memory, and between the processor and PCI or ISA local buses.

Bus mastering: allows peripheral devices and IDEs to access the system memory without going through the CPU (similar to DMA channels).

Cache: a temporary storage area for data that will be needed often by an application. Using a cache lowers data access times, since the needed information is stored in the SRAM instead of in the slow DRAM. Note that the cache is also much smaller than your regular memory: a typical cache size is 512KB, while you may have as much as 4GB of regular memory.

Cache size: refers to the physical size of the cache onboard. This should not be confused with the cacheable area, which is the total amount of memory which can be scanned by the system in search of data to put into the cache. A typical setup would be a cache size of 512KB, and a cacheable area of 512MB. In this case, up to 512KB of the main memory onboard is capable of being cached. However, only 512KB of this memory will be in the cache at any given moment. Any main memory above 512MB could never be cached.

Closed and open jumpers: jumpers and jumper pins are active when they are “on” or “closed”, and inactive when they are “off” or “open”.

CMOS (Complementary Metal-Oxide Semiconductors): chips that hold the basic startup information for the BIOS.

COM port: another name for the serial port, which is called as such because it transmits the eight bits of a byte of data along one wire, and receives data on another single wire (that is, the data is transmitted in serial form, one bit after another). Parallel ports transmit the bits of a byte on eight different wires at the same time (that is, in parallel form, eight bits at the same time).

DDR (Double Data Rate): is a technology designed to double the clock speed of the memory. It activates output on both the rising and falling edge of the system clock rather than on just the rising edge, potentially doubling output.

DIMM (Dual In-line Memory Module): faster and more capacious form of RAM than SIMMs, and do not need to be installed in pairs.

DIMM bank: sometimes called DIMM sockets, because the physical slot and the logical unit are the same. That is, one DIMM module fits into one DIMM socket, which is capable of acting as a memory bank.

DMA (Direct Memory Access): channels that are similar to IRQs. DMA channels allow hardware devices (like soundcards or keyboards) to access the main memory without involving the CPU. This frees up CPU resources for other tasks. As with IRQs, it is vital that you do not double up devices on a single line. Plug-n-Play devices will take care of this for you.

Doze mode: in this mode, only the CPU's speed is slowed.

DRAM (Dynamic RAM): widely available, very affordable form of RAM which has the unfortunate tendency to lose data if it is not recharged regularly (every few milliseconds). This refresh requirement makes DRAM three to ten times slower than non-recharged RAM such as SRAM.

ECC (Error Correction Code or Error Checking and Correcting): allows data to be checked for errors during run-time. Errors can subsequently be corrected at the same time that they're found.

EEPROM (Electrically Erasable Programmable ROM): also called Flash BIOS, is a ROM chip which can, unlike normal ROM, be updated. This allows you to keep up with changes in the BIOS programs without having to buy a new chip. Tyan's BIOS updates can be found at <http://www.tyan.com>

ESCD (Extended System Configuration Data): a format for storing information about Plug-n-Play devices in the system BIOS. This information helps properly configure the system each time it boots.

Fault-tolerance: a term describing a system where one component can quickly be replaced without causing a loss of service, such as in a **RAID** system.

Firmware: low-level software that controls the system hardware.

Form factor: an industry term for the size, shape, power supply type, and external connector type of the Personal Computer Board (PCB) or motherboard. The standard form factors are the AT and ATX, although Tyan also makes some Baby-AT and ATX Footprint boards.

Global timer: onboard hardware timer, such as the Real-Time Clock (RTC).

Handshaking: a form of encryption. One system, typically the server, sends an encryption scheme to another agent, typically a client. Thus, the client's data is protected during transmittal to the server.

HDD: stands for Hard Disk Drive, a type of fixed drive.

H-SYNC: controls the horizontal synchronization/properties of the monitor.

IC (Integrated Circuit): the formal name for the computer chip.

IDE (Integrated Device/Drive Electronics): a simple, self-contained HDD interface. It can handle drives up to 8.4 GB in size. Almost all IDEs sold now are in fact Enhanced IDEs (EIDEs), with maximum capacity determined by the hardware controller.

IDE INT (IDE Interrupt): a hardware interrupt signal that goes to the IDE.

I/O (Input/Output): the connection between your computer and another piece of hardware (mouse, keyboard, etc.)

Initial Program Load (IPL): a feature built into BBS-compliant devices, describing those devices as capable of loading and executing an OS, as well as being able to provide control back to the BIOS if the loading attempt fails.

IPL: see **Initial Program Load**.

IRQ (Interrupt Request): an electronic request that runs from a hardware device to the CPU. The interrupt controller assigns priorities to incoming requests and delivers them to the CPU. It is important that there is only one device hooked up to each IRQ line; doubling up devices on IRQ lines can lock up your system. Plug-n-Play operating systems can take care of these details for you.

ISA (Industry Standard Architecture): a slower 8- or 16-bit bus (data pathway).

Latency: the amount of time that one part of a system spends waiting for another part to catch up. This is most common when the system sends data out to a peripheral device, and it waiting for the peripheral to send some data back (peripherals tend to be slower than onboard system components).

Mirroring: see **RAID**.

NVRAM: ROM and EEPROM are both examples of Non-Volatile RAM, memory that holds its data without power. DRAM, in contrast, is volatile.

OEMs (Original Equipment Manufacturers): Compaq or IBM package other companies' motherboards and hardware inside their case and sell them.

Parallel port: transmits the bits of a byte on eight different wires at the same time (that is, in parallel form, eight bits at the same time).

PCI (Peripheral Component Interconnect): a 32 or 64-bit local bus (data pathway) which is faster than the ISA bus. Local buses are those which operate within a single system (as opposed to a network bus, which connects multiple systems).

PCI PIO (PCI Programmable Input/Output) modes: the data transfer modes used by IDE drives. These modes use the CPU for data transfer (in contrast, DMA channels do not). PCI refers to the type of bus used by these modes to communicate with the CPU.

PCI-to-PCI bridge: allows you to connect multiple PCI devices onto one PCI slot.

Pipeline burst SRAM: a fast secondary cache. It is used as a secondary cache because SRAM is slower than SDRAM, but usually larger. Data is cached first to the faster primary cache, and then, when the primary cache is full, to the slower secondary cache.

Pipelining: improves system performance by allowing the CPU to begin executing a second instruction before the first is completed. A pipeline can be likened to an assembly line, with a given part of the pipeline repeatedly executing a set part of an operation on a series of instructions.

PM timers (Power Management timers): software timers that count down the number of seconds or minutes until the system times out and enters sleep, suspend, or doze mode.

PnP (Plug-n-Play): a design standard that has become ascendant in the industry. Plug-n-Play devices require little set-up to use. Novice end users can simply plug them into a computer that is running on a Plug-n-Play aware operating system (such as Windows 98), and go to work. Devices and operating systems that are not Plug-n-Play require you to reconfigure your system each time you add or change any part of your hardware.

PXE (Preboot Execution Environment): one of four components that together make up the Wired for Management 2.0 baseline specification. PXE was designed to define a standard set of preboot protocol services within a client, towards the goal of allowing networked-based booting to boot using industry standard protocols.

RAID (Redundant Array of Independent Disks): a way for the same data to be stored in different places on many hard drives. By using this method, the data is stored redundantly, also the multiple hard drives will appear as a single drive to the operating system. RAID level 0 is known as striping, where data is striped (or overlapped) across multiple hard drives, but offers no fault-tolerance. RAID level 1 is known as mirroring, which stores the data within at least two hard drives, but does not stripe. RAID level 1 also allows for faster access time and fault-tolerance, since either hard drive can be read at the same time. RAID level 0+1 is both striping and mirroring, providing fault-tolerance, striping, and faster access all at the same time.

RAM (Random Access Memory): technically refers to a type of memory where any byte can be accessed without touching the adjacent data, is often used to refer to the system's main memory. This memory is available to any program running on the computer.

ROM (Read-Only Memory): a storage chip which contains the BIOS; the basic instructions required to boot the computer and start up the operating system.

SDRAM (Synchronous Dynamic RAM): called as such because it can keep two sets of memory addresses open simultaneously. By transferring data alternately from one set of addresses and then the other, SDRAM cuts down on the delays associated with non-synchronous RAM, which must close one address bank before opening the next.

Serial port: called as such because it transmits the eight bits of a byte of data along one wire, and receives data on another single wire (that is, the data is transmitted in serial form, one bit after another).

SIMM (Single In-line Memory Module): formerly the most common form of RAM for motherboards. They must be installed in pairs, and do not have the carrying capacity or the speed of DIMMs.

Sleep/Suspend mode: in this mode, all devices except the CPU shut down.

SRAM (Static RAM): unlike DRAM, this type of RAM does not need to be refreshed in order to prevent data loss. Thus, it is faster, and more expensive.

Standby mode: in this mode, the video and fixed disk drive (usually the HDD) shuts down; all other devices continue to operate normally.

Striping: see RAID.

UltraDMA/33/66/100: a fast version of the old DMA channel. UltraDMA is also called UltraATA. Without the proper UltraDMA controller, your system cannot take advantage of the higher data transmission rates of the new UltraDMA/UltraATA HDDs.

USB (Universal Serial Bus): a versatile port. This one port type can function as a serial, parallel, mouse, keyboard, or joystick port. It is fast enough to support video transfer, and is capable of supporting up to 127 daisy-chained peripheral devices.

VGA (Video Graphics Array): the PC video display standard.

V-SYNC: controls the vertical properties of the monitor.

ZIF socket (Zero Insertion Force socket): these sockets make it possible to insert CPUs without damaging the sensitive CPU pins. The CPU is lightly placed in an open ZIF socket, and the metal level is pulled down. This shifts the processor over and down, guiding it into place on the board.

Technical Support

If a problem arises with your system, you should turn to your dealer for help first. Your system has most likely been configured by them, and they should have the best idea of what hardware and software your system contains. Hence, they should be of the most assistance. Furthermore, if you purchased your system from a dealer near you, you can actually bring your system to them to have it serviced, instead of attempting to do so yourself (which can have expensive consequences).

Help Resources:

1. See the FAQ and beep codes section of this manual.
2. See the Tyan website for FAQ, bulletins, driver updates, and other information: <http://www.tyan.com>
3. Contact your dealer for help **BEFORE** calling Tyan.
4. Check the Tyan user group: alt.comp.periphs.mainboard.tyan

Returning Merchandise for Service

During the warranty period, contact your distributor or system vendor **FIRST** for any product problems. This warranty only covers normal customer use and does not cover damages incurred during shipping or failure due to the alteration, misuse, abuse, or improper maintenance of products.

NOTE: A receipt or copy of your invoice marked with the date of purchase is required before any warranty service can be rendered. You may obtain service by calling the manufacturer for a Return Merchandise Authorization (RMA) number. The RMA number should be prominently displayed on the outside of the shipping carton and the package should be mailed prepaid. Tyan will pay to have the board shipped back to you.

**Notice for the USA**

Compliance Information Statement (Declaration of Conformity Procedure) DoC
FCC Part 15: This device complies with Part 15 of the FCC Rules.

Operation is subject to the following conditions:

- 1) this device may not cause harmful interference, and
- 2) this device must accept any interference received including interference that may cause undesired operation. If this equipment does cause harmful interference to radio or television reception, which can be determined by turning the equipment off and on, the user is encouraged to try one or more of the following measures:
 - Reorient or relocate the receiving antenna.
 - Increase the separation between the equipment and receiver.
 - Plug the equipment into an outlet on a circuit different from that of the receiver.
 - Consult the dealer or an experienced radio/television technician for help.

Notice for Canada

This apparatus complies with the Class B limits for radio interference as specified in the Canadian Department of Communications Radio Interference Regulations. (Cet appareil est conforme aux normes de Classe B d'interférence radio tel que spécifié par le Ministère Canadien des Communications dans les règlements d'interférence radio.)

**Notice for Europe (CE Mark)**

This product is in conformity with the Council Directive 89/336/EEC, 92/31/EEC (EMC).

CAUTION: Lithium battery included with this board. Do not puncture, mutilate, or dispose of battery in fire. Danger of explosion if battery is incorrectly replaced. Replace only with the same or equivalent type recommended by manufacturer. Dispose of used battery according to manufacturer instructions and in accordance with your local regulations.