

M-Series OTDRs

User's Guide

Limited Warranty

All NOYES test equipment products are warranted for a period of (1) one year from the date of delivery to the end user. Extended warranties start at the end of the standard (1) one year warranty period.

1 year, 2 year, and 4 year extended warranties are available for NOYES products with or without annual calibration included. Please see our website at http://www.AFLglobal.com/products/test_inspection/accessories_services/Calibration_Repair_Services.html for more information.

Any product that is found defective within the warranty period will, at the discretion of AFL, be repaired or replaced. Warranty will be voided if the product has been repaired or altered by other than an authorized NOYES product repair facility, if the void sticker has been compromised, or which have been subject to misuse, negligence, or accident. In no case shall AFL liabilities exceed the original purchase price.

CE Information



These instruments have been designed and tested to comply with the relevant sections of any applicable specifications including full compliance with all essential requirements of all applicable EU Directives.

Returning Equipment

To return equipment, please contact NOYES to obtain additional information and a Service Request (S.R.) number. To allow us to serve you more efficiently, please include a brief description specifying the reasons for the return of the equipment.

AFL

NOYES Test and Inspection

16 Eastgate Park Road

Belmont, NH 03220

Tel: 800-321-5298

603-528-7780

Fax: 603-528-2025

This is a user's guide for the M-series OTDR. It assumes basic knowledge in the use of an OTDR, OPM, and a PC.



Table of Contents

Safety Information	4
Getting Started: Front Panel Keys	5
Main Menu: Selecting the Mode	6
Menus Tip: "... " Function	6
M700 Series.	6
M200 Series.	6
Getting Started: Display Features	7
Setup: General Settings.	10
Setup: Full Auto Mode Settings	11
Setup: Expert Mode Settings	12
Setup: Real-Time Mode Settings	13
Setup: Event Settings	14
Event Settings: Pass/Fail	15
Setup: OPM Mode Settings (M700 only).	16
Setup: New Job Creation	19
Setup: New Job Creation	20
Setup: Results Manager	21
Job Creation in Results Manager	22
Job Selection from Results Manager	23
Job Selection from a Test Mode	24
Opening a Trace File for Review	25
Saving Test Results	25
Converting M200 old User Interface files into new file format	26
Running Tests & Viewing Results	31
Trace Page Features	32
M700 Series.	32
M200 Series.	32
Event Table & Summary Results	35
Fault Locating: Full Auto	36
Two Point A/B Measurement	36
Text Editor	37
Numerical Editor	37
Transferring Files	38
Recommended Accessories.	39
Cleaning Tips	40
FAQs	42
Tips: Expert OTDR Setup.	42
Recharging Batteries	43
Repair and Calibration	43
Contact Us	44

Safety Information



WARNING! Use of procedures or adjustments other than those specified herein may result in hazardous radiation exposure.

850/1300 nm multimode OTDR port	<p>This is a CLASS I LASER output</p> 
1310/1550 nm single-mode OTDR port	<p>This is a CLASS I LASER output</p> 
VFL port	<p>This is a CLASS II LASER output. Do not stare into beam</p> 



CAUTION! To avoid serious eye injury, never look directly into the optical outputs of fiber optic network equipment, test equipment, patch cords, or test jumpers. Refer to your company's safety procedures when working with optical systems.



WARNING! Use only the specified AC adapter. Use of another type of AC adapter can damage the instrument and create the danger of fire and electrical shock.



WARNING! To avoid the danger of fire and electrical shock:

- Never use a voltage that is different from that for which the AC adapter is rated.
- Do not plug the unit into a power outlet that is shared by other devices.
- Never modify the power cord or excessively bend, twist, or pull it.
- Do not allow the power cord to become damaged. Do not place heavy objects on the power cord or expose it to heat.
- Never touch the AC adapter while your hands are wet.
- Should the power cord become seriously damaged (internal wiring exposed or shorted), contact the manufacturer to request servicing.



CAUTION! Do not run any tests or perform functions that activate an OTDR laser unless fiber is attached to the corresponding OTDR port.













NOTICE! NOYES OTDR contains no user serviceable parts. Except for changing batteries and cleaning optical ports, this instrument must be returned to NOYES or authorized agents for repair and calibration.

IMPORTANT! Proper care in handling should be taken when using any precision optical test equipment. Scratched or contaminated optical connectors can impact the performance of the instrument. It is important to keep the dust caps in place when the unit is not being used.

Getting Started: Front Panel Keys

The use of each key is summarized in the table below.

KEY SYMBOL	KEY NAME	KEY FUNCTION
	Power	Press and hold (approx. 1 sec.) to turn an OTDR on or off
	VFL laser	ON 2Hz - Press and hold (approx. 2 sec.) LED will flash ON CW - Press and hold (approx. 4 sec.) LED will be solid OFF - Press and hold (approx. 1 sec.) LED should be OFF
	Menu	Press to access the Main Menu
	Left and Right Tab keys	Press to display the next/previous available Home and Settings pages or View tab
	Arrow keys	The arrow keys provide several functions: <ul style="list-style-type: none"> • In the Home and Settings pages, Main Menu and Results pages, these keys are used to navigate menus and change setup parameters • In the Trace page, these keys are used to move the cursors • In the Zoom Adjust page, these keys adjust vertical and horizontal zoom levels • In the LSA Adjust page these keys move cursors and adjust zoom levels
	Enter	This key provides several functions: <ul style="list-style-type: none"> • On the Main Menu page: press this key to open a Test Mode, Results Manager, Settings, or New Job • On Settings pages: for setting followed by “...” press this key to open a submenu • On the Trace page: press this key to toggle between [A] and [B] cursor
	Back	Press one or more times, depending on which menu or editor submenu is displayed, to return to the current mode Home page
	Test	Press to start or stop a test
	Save	Press to save the currently displayed test results
	Backlight	Press to set level of brightness
	Soft keys	The label shown on the display above each key indicates the current use of each function key

Main Menu: Selecting the Mode

Two types of modes are available from the Main Menu as follows:

TEST MODES: OTDR and OPM	
Used to perform OTDR and OPM tests	To select the desired mode <ul style="list-style-type: none"> • Tap the appropriate touch screen icon • Use ◀▶ arrows to indicate the desired mode icon, and then press ⏪/⏩ key
UTILITY MODES: Results, Settings, and New Job	
Used to select user preferences, perform general settings, create a new job (set up a file structure and define the fiber under test location), manage saved test results, and perform other non-test functions	To select the desired mode <ul style="list-style-type: none"> • Tap the appropriate touch screen icon • Press the appropriate soft key located below each touch screen icon

M700 Series

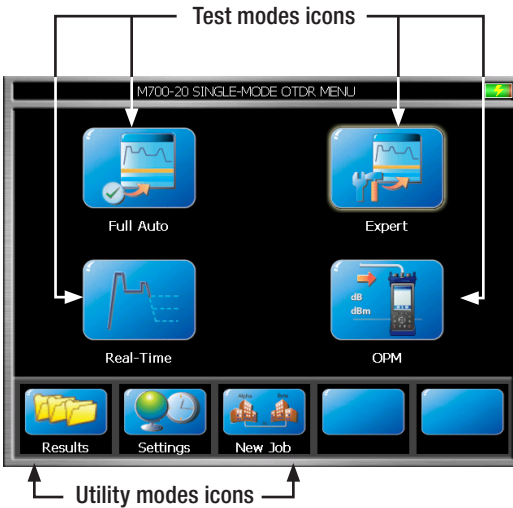

M200 Series

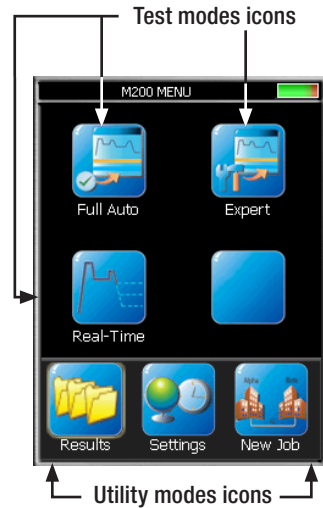

Menus Tip: “...” Function

When a menu option is followed by three dots “...”, it means that there is a submenu/ page available. Press ⏪/⏩ key to display and see additional information.

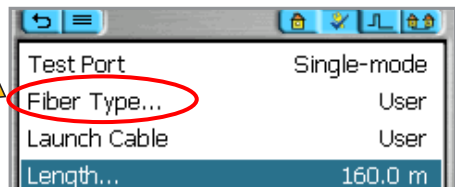

Getting Started: Display Features

Test Settings View

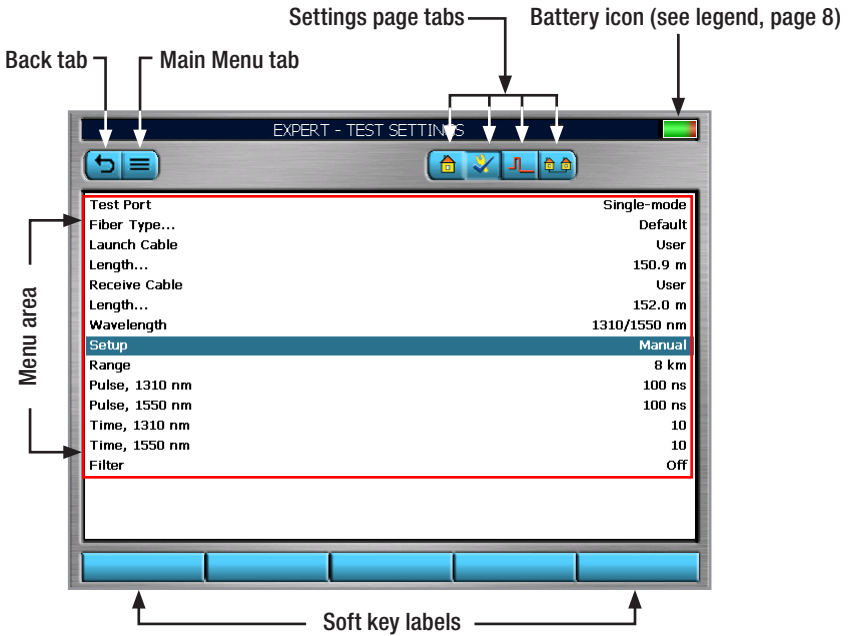

Settings Page Tabs

Full Auto/Expert OTDR mode



Real-Time OTDR mode



OPM mode

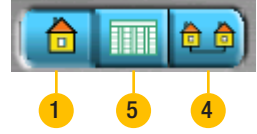

Press tabs to perform the following:

- 1 **Home mode** - display OTDR setup, change Fiber and Cable ID parameters
- 2 **Test Settings** - define OTDR test setup
- 3 **Event Settings** - define Events settings and Pass/Fail Settings
- 4 **Job Settings** - define Job, End Locations, Cable ID, and Operator parameters
- 5 **Data Table (OPM test mode only!)** - review OPM test results

Getting Started: Display Features

OTDR Trace View

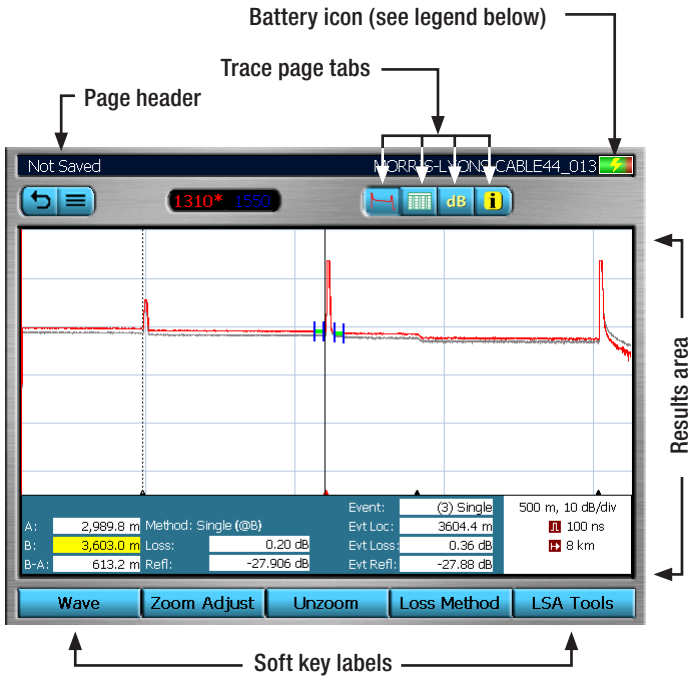

BATTERY ICON	BATTERY STATUS
	Green - fully charged
	Red - discharged

BATTERY ICON	BATTERY STATUS
	Charging - AC connected
	Fully Charged - AC connected







Trace Page Tabs



Press tabs to display test data as follows:

- 1 **Trace page** - OTDR trace, test setup, A/B cursor data, Loss Method, Loss, Reflectance
- 2 **Event Table** - OTDR trace; event Location, Type, Reflectance, Loss, event Pass/Fail (if turned On)
- 3 **Summary Table** - OTDR trace, Link Length, ORL, Loss, link Pass/Fail (if turned On)
- 4 **Job Information** - setup parameters of the currently displayed trace

Main Menu: Selecting the Mode

TEST MODES: OTDR and OPM		
Test Mode	Icon	Description
Full Auto OTDR	 Full Auto	This is the recommended mode for users who are not familiar with OTDR operation. In the Full Auto mode, OTDR parameters such as Range, Pulse Width, and Averaging Time are set automatically. Tests are done at two wavelengths and always include an Event Table and Summary page. Pass/Fail Thresholds are set to default with an option to be turned off. Note: in the Expert mode, the Events Menu contains Event Threshold and Pass/Fail Threshold Settings allowing the user to change these settings and turn them on or off.
Real-Time OTDR	 Real-Time	This is the best mode for real-time troubleshooting. Note that the Wavelength setting can only be set to individual wavelengths. The Range, Pulse Width, and Filter parameters are set by the user.
Expert OTDR	 Expert	This mode is available for experienced users. It provides the most setup flexibility. Users can set Range, Pulse Width, and Averaging Time manually (Setup = Manual) or automatically (Setup = Auto Once or Setup = Auto). Users can either enable the event table (Events = Auto) or disable the event table (Events = Off). Note: in the Expert mode, the Events Menu contains Event Threshold and Pass/Fail Threshold Settings allowing the user to change these settings and turn them on or off.
OPM M700 only!	 OPM	This mode is available to perform Optical Power Meter measurements.
UTILITY MODES: Results, Settings, and New Job		
Results	 Results	This mode provides the file manager functions to handle the results of OTDR, OPM tests and to set up Jobs.
Settings	 Settings	This mode allows the user to adjust General Settings (Language, Distance Units, Sounds, Auto Off function, Date/Time, Company Name) and displays the OTDR version information.
New Job	 New Job	This mode is available for creating new jobs (setting up a file structure and defining the fiber under test location: Drives, Folders, Jobs, Routes [End Locations], Cables, Test Equipment Location, and Operators).

Setup: General Settings

The General Settings may be completed as indicated below.

Press ⏪/⏩ key to display submenu, which allows the selection of available languages

Press ⏪/⏩ key to display submenu, which allows the selection of available date/time/numbers formatting options

Use ⏪/⏩ arrows to select units of measure

Use ⏪/⏩ arrows to toggle the Beeper function On/Off

Use ⏪/⏩ arrows to define the Auto Off (set number of minutes) function

Press ⏪/⏩ key to display submenu, which allows setting Date

Press ⏪/⏩ key to display submenu, which allows setting Time

Press ⏪/⏩ key to display submenu, which allows defining Company Name

Press ⏪/⏩ key to display Touch Panel calibration screen

Press ⏪/⏩ key to reset all Settings to the default values

Press ⏪/⏩ key to display the System Information screen
Note: This page contains all information the user would need to have available in case of returning test equipment or contacting NOYES Technical Support department for assistance.

GENERAL SETTINGS

- Language...
- Formatting...
- Distance Units Meters
- Beeper On
- Auto Off (minutes)... 0
- Date... 2010/02/26
- Time... 02:17 PM
- Company Name... Name1
- Calibrate Screen...
- Reset All Settings to Default...
- View System Information...

Edit

SYSTEM INFORMATION

- Calibration Date 2010/01/14
- Serial Number: 1X01MREXN306295
- M200 Version 1.4.48.0
- OS Version 1.1.3.21
- OS Build Date 2008/07/22
- Power Interface 1.4.0.11
- Power Controller 1.0.1
- OTDR Interface 1.0.0.1
- OTDR Version 1.0.0

OK

Setup: Full Auto Mode Settings

Core Settings

Full Auto mode settings are common for all OTDR Test modes and will be referred to as Core Settings.

PARAMETER	DEFINITION
Test Port	This parameter indicates that a multimode or single-mode laser is used to generate an OTDR trace
Fiber Type	This parameter is used to set fiber type which determines the GIR and Backscatter Coefficient
Launch Cable (Launch Cord) see page 31	A test cable used to connect the OTDR to the near end of the link under test that is long enough to allow the OTDR to measure the loss of the first connection under the test
Receive Cable (Tail Cord)	A test cable used to terminate the far end of the link under test that is long enough for the OTDR to measure the loss of the last connection

Use ◀▶ arrows to select Single-mode or Multimode Test Port (QUAD models). For the single-mode M700 OTDR, Single-mode Test Port is the default setting.

Use ◀▶ arrows to select Fiber Type. If set to [User], press ⏪/⏩ key to display submenu, which allows defining the GIR and Backscatter parameters.

Use ◀▶ arrows to select the Launch Cable option. If set to [User], set [Length] parameter.

Press ⏪/⏩ key to display editor submenu, which allows setting the Length of the Launch Cable used.

Use ◀▶ arrows to select the Receive Cable option. If set to [User], set [Length] parameter.

Press ⏪/⏩ key to display editor submenu, which allows setting the Length of the Receive Cable used.

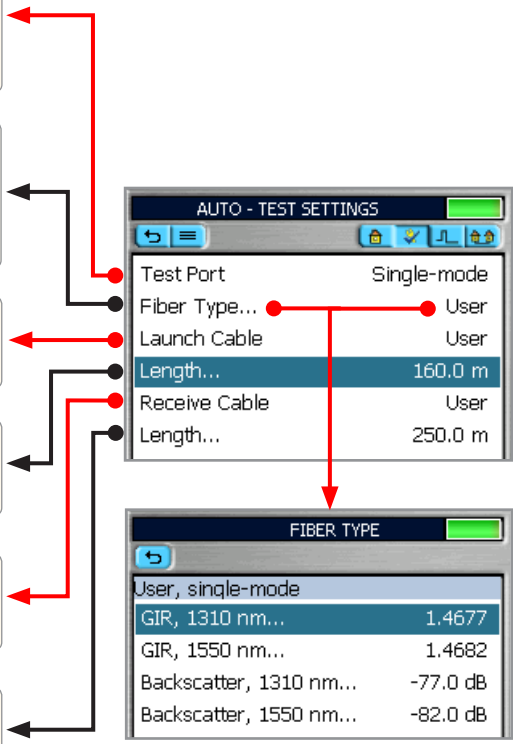

Setup: Expert Mode Settings

In addition to Core Settings (see Full Auto mode settings), the Expert test mode allows you to set the Wavelength, Range, Pulse Width, Averaging Time, and Filter parameters.

Setup - Auto

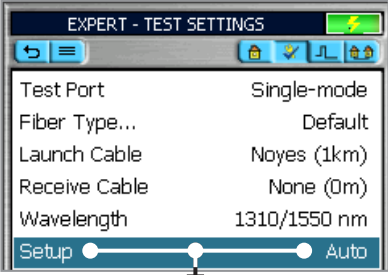

If set to [Auto], OTDR sets Range, Pulse Width, Time, and Filter for each test.

Use ◀▶ arrows to select a single wavelength or dual wavelengths for next tests.

Setup - Auto Once

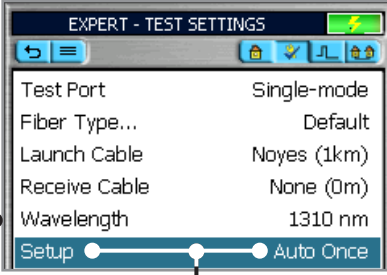

If set to [Auto Once], OTDR sets Range, Pulse Width, Time, and Filter for the first test. After test, returns user to OTDR Home page in Manual mode, where user may change any setting for next tests.

Setup - Manual

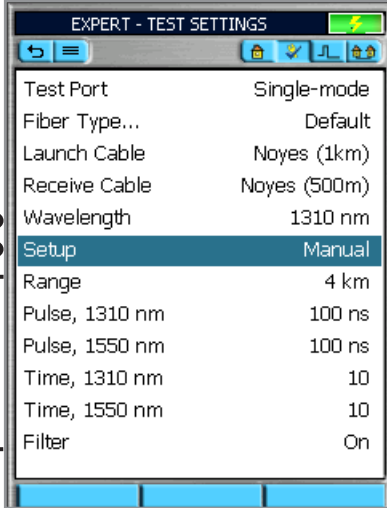

Use ◀▶ arrows to select a single wavelength or dual wavelengths

If set to [Manual], you will need to set Range, Pulse, Time, and Filter

Use ◀▶ arrows to display the desired value or option

Setup: Expert Mode Settings

Setup - Manual (continued)

Note: The Range, Pulse Width, and Averaging Time parameters are user-selectable if the [Setup] parameter is set to [Manual].

PARAMETER	DESCRIPTION															
Range	<p>The Range parameter determines the distance range of the full (unzoomed) trace. It also determines Resolution - the distance between data points in the trace: the longer the range, the wider the data point spacing. We recommend selecting the shortest distance range that is longer than the fiber under test. For example, to test a fiber that is 1.5 km long (including launch and receive cables), select the 2 km range. Available Range values:</p> <table border="1"> <thead> <tr> <th>Wavelength (nm)</th> <th>Distance Range</th> <th>Resolution (set by OTDR)</th> </tr> </thead> <tbody> <tr> <td rowspan="2">MM 850, MM 1300</td> <td>≤ 2 km (6561ft)</td> <td>0.125 m (0.41 ft)</td> </tr> <tr> <td>< 4 km (13123 ft)</td> <td>0.25 m (0.82 ft)</td> </tr> <tr> <td rowspan="3">SM 1310, SM 1550, SM 1625</td> <td>8 km (26246 ft)</td> <td>0.5 m (1.64 ft)</td> </tr> <tr> <td>16 km (52493 ft)</td> <td>1 m (3.28 ft)</td> </tr> <tr> <td>≥ 32 km (104986 ft)</td> <td>range/16 km (range/5249 ft)</td> </tr> </tbody> </table>	Wavelength (nm)	Distance Range	Resolution (set by OTDR)	MM 850, MM 1300	≤ 2 km (6561ft)	0.125 m (0.41 ft)	< 4 km (13123 ft)	0.25 m (0.82 ft)	SM 1310, SM 1550, SM 1625	8 km (26246 ft)	0.5 m (1.64 ft)	16 km (52493 ft)	1 m (3.28 ft)	≥ 32 km (104986 ft)	range/16 km (range/5249 ft)
Wavelength (nm)	Distance Range	Resolution (set by OTDR)														
MM 850, MM 1300	≤ 2 km (6561ft)	0.125 m (0.41 ft)														
	< 4 km (13123 ft)	0.25 m (0.82 ft)														
SM 1310, SM 1550, SM 1625	8 km (26246 ft)	0.5 m (1.64 ft)														
	16 km (52493 ft)	1 m (3.28 ft)														
	≥ 32 km (104986 ft)	range/16 km (range/5249 ft)														
Pulse Width	The M-series OTDR can operate using different pulse widths. Short pulse widths provide the shortest event and attenuation dead zones. Long pulse widths provide the best event detection on long fibers.															
Averaging Time	The [Time] parameter determines the duration of a timed test. Available time settings: 5 • 10 • 30 • 60 • 90 • 180 sec															

Setup: Real-Time Mode Settings

In addition to Core Settings, the Real Time mode allows you to set the Wavelength, Range, Pulse Width, and Filter parameters.

The screenshot shows the 'REAL-TIME - TEST SETTINGS' menu with the following options:

- Test Port: Single-mode
- Fiber Type...: Default
- Launch Cable: Noyes (150m)
- Receive Cable: None (0m)
- Wavelength: 1310 nm
- Range: 4 km
- Pulse, 1310 nm: 100 ns
- Filter: On

Callouts provide the following instructions:

- See Full Auto mode Settings (page 11) - points to the 'Test Port' and 'Fiber Type...' options.
- Use ◀▶ arrows to select a wavelength - points to the 'Wavelength' option.
- Use ◀▶ arrows to display the desired value or option - points to the 'Range', 'Pulse, 1310 nm', and 'Filter' options.

Setup: Event Settings

The Event Settings Menu features three parameters: Events, Event Thresholds, and Pass/Fail Thresholds.

In **Full Auto OTDR** test mode these parameters are set as follows:

- Events - set to Auto and an Event Table is calculated for every test.
- Event Thresholds - set to Default. Press \leftarrow/\rightarrow key to view the default values (see table, pg. 15).
- Pass/Fail Thresholds - set to Default. Press \leftarrow/\rightarrow key to view the default values (see table, page 15) and turn Event Pass Thresholds On/Off (Threshold set to default values).

In **Expert OTDR** test mode, these parameters may be set as indicated below:

PARAMETER	OPTION	DESCRIPTION
Events	Auto	An Event Table is calculated for every test
	Off	Event Table is not calculated
Event Thresholds	Default	Set to default values (see table, page 15)
	User	Values may be adjusted within allowed limits (see table, page 15)
Pass/Fail Thresholds	Default	View default values (see table, page 15) and turn Event Pass Thresholds On/Off (Threshold set to default values)
	User	Values may be adjusted within allowed limits (see table, page 15)

In Expert mode: [Auto] is the default setting. Use \leftarrow/\rightarrow arrows to toggle between the [Auto] or [Off] options.

Use \leftarrow/\rightarrow arrows to select the [Default] or [User] option. If set to [User], press \leftarrow/\rightarrow key to display editor submenu, which allows defining the Threshold parameters.

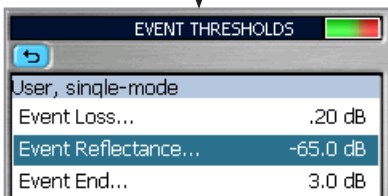

Use \leftarrow/\rightarrow arrows to select the [Default] or [User] option. If set to [User], press \leftarrow/\rightarrow key to display a submenu, which allows defining Event and Link Pass/Fail and Marginal Threshold values.

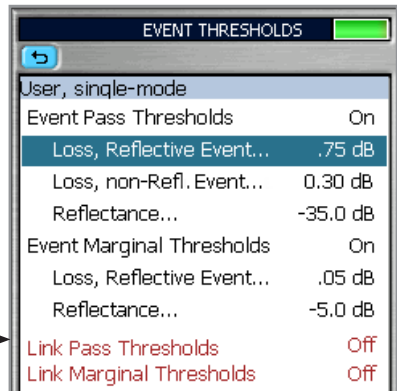
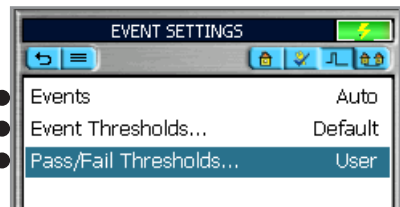

Event Settings: Pass/Fail

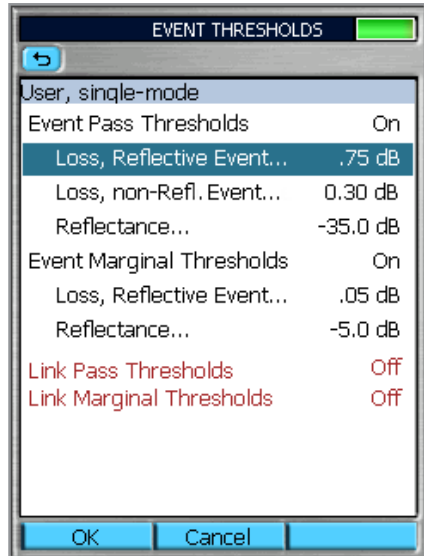
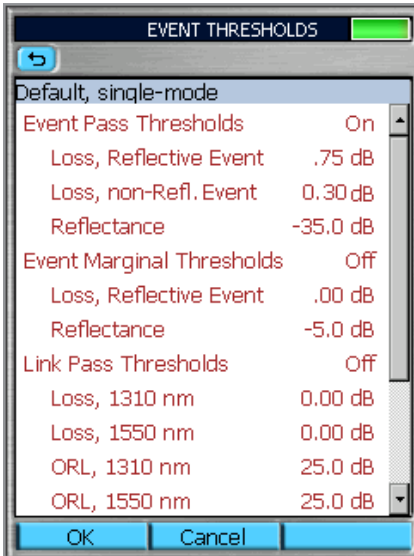

Event Thresholds Chart

Threshold	Min Value (dB)	Default Value (dB)	Max Value (dB)
Event Loss	0.05	0.10	1.0
Event Reflectance	-65.0	-65.0	-35.0
Event End	1.0	3.0	25.0

Event Pass Thresholds

Threshold	Min Value (dB)	Default Value (dB)	Max Value (dB)
Event Pass Thresholds			
Loss, Reflective Event	0.05	0.75	3.00
Loss, Non-reflective Event	0.05	0.30	3.00
Reflectance: 1310, 1550, 1625 nm	-65.0	-35.0	-20.0
Reflectance: 850, 1300 nm	-45.0	-22.0	-15.0
Event Marginal Thresholds			
Loss, Reflective Event	0.00	0.00	1.00
Reflectance	0.00	-5.00	-10.0
Link Pass Thresholds			
Loss: 850, 1300, 1310, 1550, 1625 nm	0.00	0.00	35.0
ORL: 850, 1300, 1310, 1550, 1625 nm	20.0	25.0	65.0
Link Marginal Thresholds			
Loss: 850, 1300, 1310, 1550, 1625 nm	0.00	0.00	5.00
ORL: 850, 1300, 1310, 1550, 1625 nm	0.00	0.00	10.0

Setup: OPM Mode Settings (M700 only)

OPM Page Tabs



Press tabs to perform the following:

- 1 **Home mode** - display the OPM setup, current test values, and Reference values. From the Home mode page you may change Fiber and Cable ID parameters.
- 2 **Data Table** - review OPM test results.
- 3 **Job Settings** - review/define Job, Locations, Cable ID, and Operator parameters.

Home Page Indicators

This field displays the current OPM test mode
Wave ID: receiving wavelength ID'd light
Tone in Hz: receiving tone signal in Hz

This field displays test readings:

- Measured Insertion Loss values in dB or measured Power in dBm or mW
- If the power or loss is too high/low for the OPM to measure, [High]/[Low] label is displayed in place of the Loss or Power values

Displays the currently selected or detected wavelength(s)

Location and Operator ID are user set in the Job Setting Menu

Fiber Number - user set





- Use \updownarrow arrows to select the [Fiber] parameter
- Use $\leftarrow \rightarrow$ arrows to increment/decrement the Fiber number one number at a time
- Press \leftarrow / \rightarrow key to open a numerical editor, which allows entering a fiber number from 001 to 999

Cable ID - user set

- Use \updownarrow arrows to select the [Cable ID] parameter
- Press \leftarrow / \rightarrow key to open the Results Manager, which allows the user to make changes to the Job Settings

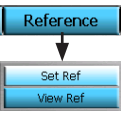
Home Page Soft Keys/Touch Screen Icons

Note: The current function of each soft key is indicated by an icon or label on the Touch Screen. If you prefer using the Touch Screen, tap the appropriate icon or label.

KEY	ICON	FUNCTION
Wavelength		In CW mode: Press this key, and then use \blacktriangle arrows to select an available wavelength. In Wave ID mode: this soft key is not available, the detected wavelength(s) will be automatically displayed.
Reference		Press the Reference key, and then use \blacktriangle arrows to select the following keys: [Set Ref] key to store the reference value(s) for the currently selected/detected wavelength(s) in Loss mode. [View Ref] key to display the saved Reference value(s).
Units		Press this key, and then use \blacktriangle arrows to select the available units of measure: dB, dBm, or μ W. Select dB to measure Loss. Select dBm or μ W to measure Power.
Save		Press to save the currently displayed value(s).
Last Result		When available, press the [Last Result] key to display the last saved value(s); the key label will turn into [Live] Press the [Live] key to display the current/Live Loss/Power value(s).

OPM Operation - Testing Multimode/Single-mode Links

Step I - Set the Reference (One Jumper Method)

- From the OTDR Main Menu, select the OPM (optical power meter) test mode. Turn on your OLS (optical light source) and allow the light source to stabilize (minimum of 15 minutes).
- If not using the [Wave ID] feature, set both instruments to the desired test wavelength.
- Select the appropriate fiber optic transmit and receive test jumpers. The fiber type of these jumpers must match the fiber type of the link to be tested.

Perform one of the following:

- For Multimode testing: wrap and secure the transmit jumper five times around the appropriate diameter mandrel.
- For Single-mode testing: make a loop in a transmit jumper and secure it with a piece of tape.
TIA testing - 30 mm loop
ISO testing - 30-50 mm loop

Note: Clean both ends of the transmit jumper.

- Connect the transmit jumper to the appropriate (MM or SM) output port of the OLS.
- Mount an adapter cap on the OPM port that matches the free connector on the transmit jumper.
- Connect the free end of the transmit jumper to the OPM port.
- If measured output power is outside of the normal range (specified by manufacturer), clean all fiber connections or replace the transmit jumper. Repeat steps 4 - 7.
- To set the reference level at the current wavelength, perform the following:

- On the equipment operating in OPM mode, press the [Reference] soft key, select [Set Ref], then press  key.
- The Reference value will be displayed briefly in dBm (μW).
- Then the screen will toggle to display Loss values of the active wavelength(s) - nominally 0.00 dB.

Step II - Verify Test Jumpers

- 9 Disconnect the transmit jumper from the OPM test port.
Note: Do not disturb the transmit jumper at the OLS end.
- 10 If necessary, change the OPM adapter cap to match the connector on the receive jumper that will be connected to the OPM test port.
Note: Clean both ends of the receive jumper.
- 11 Connect the receive jumper to the OPM test port.
- 12 Mate the free ends of the transmit and receive jumpers using an appropriate adapter.
- 13 Verify that the insertion loss of this mated connector pair is under 0.75 dB, the maximum allowed by the TIA and ISO (NOYES recommends 0.4 - 0.5 dB typical), as follows:
 - Observe the displayed loss level. This is the mated connector pair insertion loss of the test jumpers in [dB].
 - If the insertion loss is not acceptable, disconnect the transmit and receive jumpers at the adapter, clean the free ends of both test jumpers and repeat steps 12 & 13.
 - If the insertion loss is still not acceptable, replace both test jumpers and repeat steps 1-13.
- 14 If the insertion loss is acceptable, disconnect the transmit and receive jumpers at the adapter.
- 15 Move the OPM and OLS to opposite ends of the link to be tested.

Step III - Measure Link Insertion Loss

- 16 Connect the free ends of the transmit and receive jumpers to the link under test.
Note: Clean jumper end that connects to patch panel prior to every test.
- 17 The OPM will measure and display the insertion loss of the link under test.
- 18 Press the [Save] key on the OPM to save the displayed measurement.
- 19 Repeat steps 16-18 for all links to be tested at the current wavelength(s).

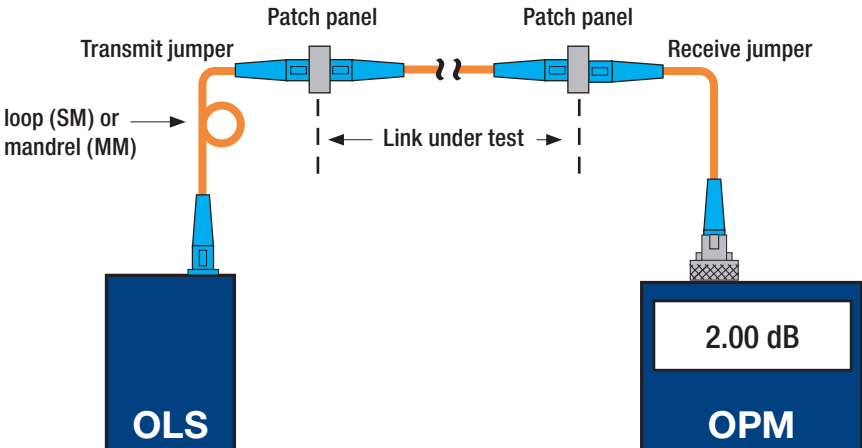

Setup: New Job Creation

The New Job utility mode is available for creating new jobs (setting up a file structure and defining the fiber under test location: Drives, Folders, Jobs, Routes [End Locations], Cables, Test Equipment Location, and Operators). The New Job utility menu is accessed from the Main Menu by tapping the New Job  touch screen icon or pressing the [New Job] soft key.



If the active job does not exist in the job hierarchy, the new job creation screen will start with all settings set to "--" as shown.

On the new job creation screen the user will be allowed to:

- Create a new job and set it as the "Active"
- Create multiple new Jobs, Routes, or Cables without closing the screen. Then select one as the "Active"
- Set global settings to a newly created job
- Add, remove, and modify static lists associated with each job setting

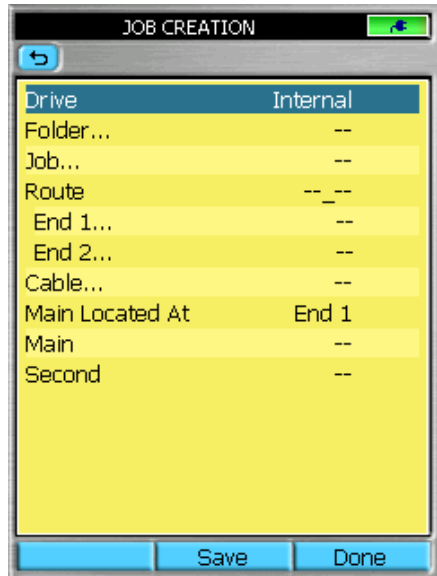

Use  arrows to navigate up/down the list of available parameters/options.

Use  arrows to scroll through the available parameters/options (if applicable).

Setup: New Job Creation

The New Job utility mode is available for creating new jobs (setting up a file structure and defining the fiber under test location: Drives, Folders, Jobs, Routes [End Locations], Cables, Test Equipment Location, and Operators).

The New Job utility menu is accessed from the Main Menu by tapping the New Job touch screen icon or pressing the [New Job] soft key. 

- Use \updownarrow arrows to navigate up/down the list of available parameters/options.
- Use $\leftarrow\rightarrow$ arrows to scroll through the available parameters/options (if applicable).
- Use \leftarrow/\rightarrow to open list of defined Folders/Jobs/Routes/Cables or create new, edit, or delete.

Press the [Select] soft key or \leftarrow/\rightarrow key to display the Job Selection screen, which allows the user to select one of the available Drive options

- Use $\leftarrow\rightarrow$ arrows to scroll through the list of existing operators
- Press the [New] soft key or \leftarrow/\rightarrow key to access a submenu, which allows the user to select one of the existing names or create a New Operator Name

Use $\leftarrow\rightarrow$ arrows to toggle between the End 1 and End 2 options

Not Saved JOB CREATION

Drive	Internal
Folder...	--
Job...	AAA
Route	MDF_IDF 204
End 1...	MDF
End 2...	IDF 204
Cable...	SM 24 FIBER
Main Located At	End 1
Main Oper...	Operator1
Second Oper...	Operator2
+ New Item	

Select Save Done

Press the [Select] soft key to access the Job Selection screen, which allows the user to select one of the available Drive/Folder/Job/Route/Cable options

Press the [Save] soft key to perform the following:

- Store the newly created Job and remain in New Job mode to add more Routes and Cables to the created Job
- Create additional new Jobs

Press the [Done] soft key to store the created new job and exit the New Job utility mode, where you can select a test mode to begin testing in the job just created

Setup: Results Manager

Note: See New Job Creation for a simplified means of creating new jobs (page 19).

The Results Manager menu is accessed from the Main Menu by tapping the Results  touch screen icon or pressing the [Results] soft key.

- Use the Results Manager to create Jobs and Review Results.
- Use the Tools menu within the Results Manager to create or delete Jobs, Files, Folders and copy test data from Internal drive to USB drive.



Results Manager “File Tree” Structure

Test results are saved as files that are stored in Cable folders. Cable folders are organized into Route, Job, and Drive folders as shown below.

OTDR test results are saved as .SOR file format and displayed on the “file tree” as  icon.

OPM power and loss readings (M700 models only) are saved as .ATD file format and displayed on the “file tree” as  icon.

DFS fiber end-faces images are saved in .JPG file format and displayed on the “file tree” as  icon.

- Use  arrows to navigate up/down the list of folders and files.
- Use  arrows to expand/contract the selected Drive/Folder/Job/Route/Cable.
- To open saved test results, navigate to the desired test file, and then press the [Open] soft key or  key.
- Use the Tools menu within the Results Manager to create or delete Jobs, Files, Folders and copy test data from Internal drive to USB drive.

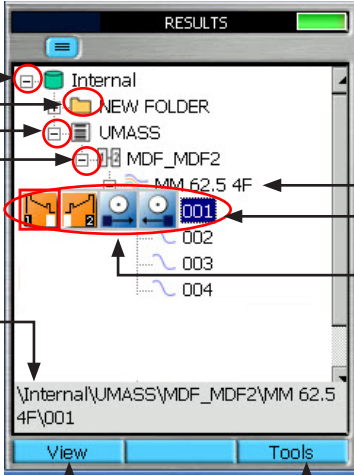

Note: Folders  are not required to store results: Job, Route, and Cables.

Note: In this example, fiber 001 contains both the OTDR results and fiber end-face images

This field displays path/ name of the selected file

Press to display selected test results

Press to display Tools menus.
Tools menus will vary depending on the selected level in the file tree structure as shown on the next page).

Job Creation in Results Manager

- 1 From the Results Manager page, use ◀▶ arrows to highlight the desired Drive where test results will be saved.
- 2 Press the [Tools] soft key to display the Tools menu (Tools menus will vary depending on the selected level in the file tree structure as shown below).
- 3 Use ⬆ arrows to highlight the [New Job] option and press ⏪/⏩ key to display the Text Editor (see page 29 for details on how to use it). Enter a name for the New Job. Press OK to return to the Results Manager page.
- 4 With the created New Job highlighted, press [Tools] > [New Route]. The Route page will be displayed.
- 5 Use ⬆ arrows to highlight [End 1...] or [End 2...]. Press [Select] or ⏪/⏩ key to display the End Locations sub-page.
- 6 To create new End Location(s), press the [New] soft key. Using the displayed Text Editor, create new End name. Press OK.
- 7 Create as many End Names as needed for a Job and press ⏪/⏩ key to return to the Route page.
- 8 From Route page, use ◀▶ arrows to select Ends for the Route. Press OK.
- 9 With the created Route highlighted, press [Tools] > [New Cable].
- 10 Using the displayed Text Editor, enter a name for the new Cable. Press OK.
If needed, create more Jobs, Routes, Cables.
- 11 With the desired Cable selected, press Main Menu ☰.
- 12 Select a Test mode to begin testing the selected Cable.
Before pressing [Test], verify test setup on the Job Settings page within the selected Test mode.

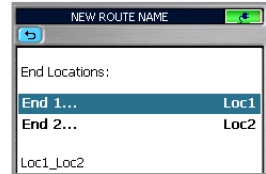

Route page

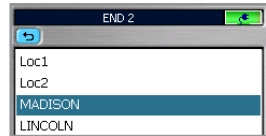

End Locations sub-page

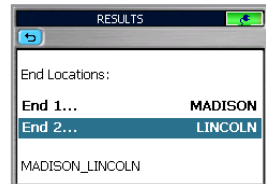

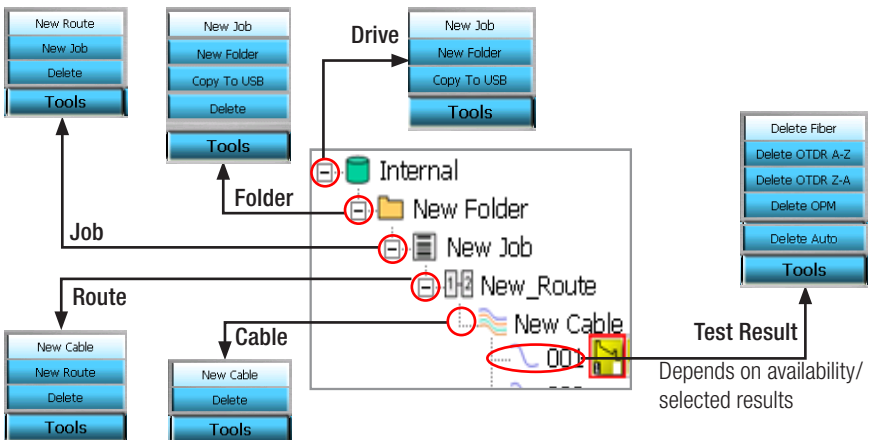

New Route selected

Tools menus in the file tree structure



Job Selection from Results Manager

To select an existing job from the Results Manager utility:

- 1 Highlight the desired cable in the Job/Route to be tested.
- 2 Press the [Open] soft key or / key to select.
- 3 The Main Menu will be displayed.
- 4 From the Main menu, select the desired test mode.
- 5 Job opens in the selected test mode with next fiber to be tested on the Home page and Job Settings page.

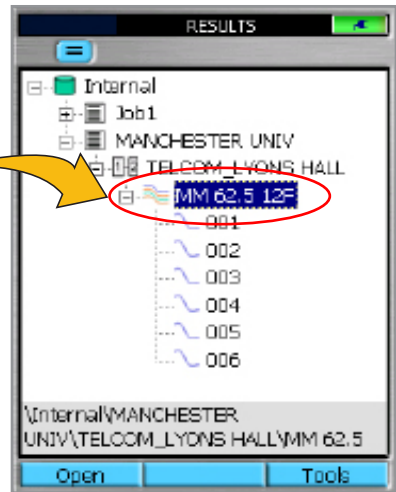

Job Selection from a Test Mode

A Job is selected from the Job Settings page, which is accessed from each test mode. Within each test mode, use tab keys to select tab and display the Job Settings page.

- 1 From the Job Settings page, use arrows to highlight Cable...
- 2 Press key to display the Results Manager page.
- 3 Use arrows to select the **Cable** within **Drive > Folder > Job > Route** you want to test and save results.
- 4 Press key to return to the Job Settings page and verify Job Parameters, equipment Location, test Operators, and starting Fiber number information.

JOB SETTINGS	
Drive...	Internal
Folder...	--
Job...	MCDOT
Cable...	MM12F62.5
End 1...	LYONS HALL
End 2...	MORRIS HALL
OTDR Located At	End 1
Fiber...	005
OTDR Operator...	SUZY
Second Operator...	PATRICK

- Use arrows to display your equipment location (End 1 or End 2)
- Use arrows to increase/decrease fiber number, or press key to display a numerical editor to set
- Press key to display submenu to define Operators' IDs using [Edit] and [New] options

Name Format (see screen above) as seen on a PC

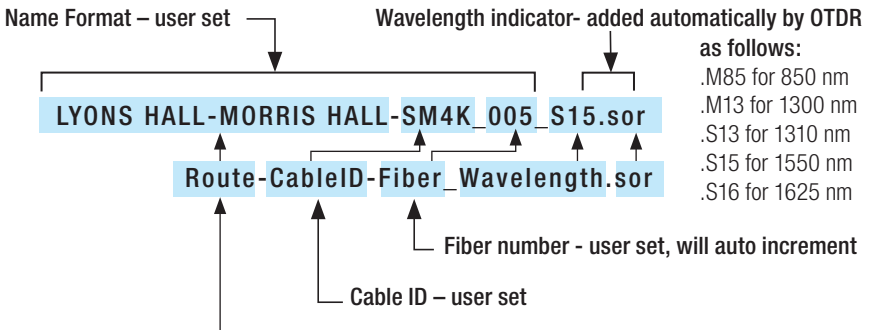

Route is made up of the two end names End 1 and End 2. They are ordered in the file name such that the first end - End 1 is where the OTDR is located or the "Near end", followed by the other end - End 2 or the "Far end".

Opening a Trace File for Review

Access Results Manager from the Main Menu by pressing the [Results] soft key.

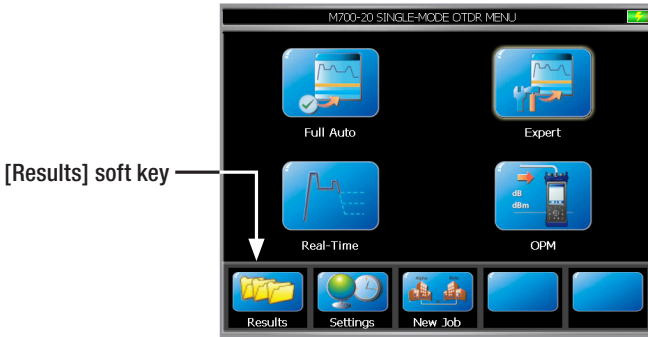

- Use the \blacktriangle arrows to navigate up/down the list of folders/files
- Use the \blacktriangleleft arrows to expand/contract the selected Drive/Folder/Job/Route/Cable
- To open saved test results, navigate to the desired file, and then press [Open]

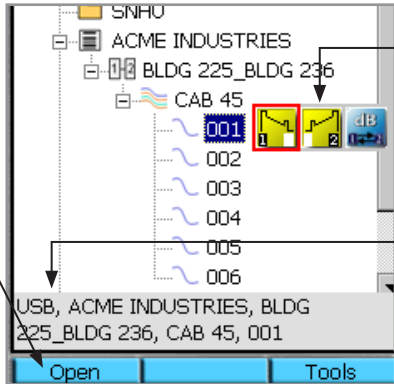

In this example, 001 is a fiber with 2 OTDR files and OPM test result in a dB file

This field displays path and name of the selected file

Saving Test Results



Save

After completing a test, press the Save key to save file in current folder with name established in the setup process.



Save-As

To change the folder, job name, or other parameter after a test has been completed, go to the Job Information tab  and make the changes.

Changes only apply to the current test!

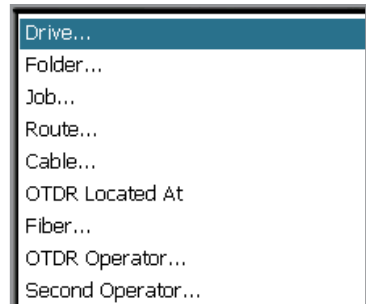

Converting M200 old User Interface files into new file format

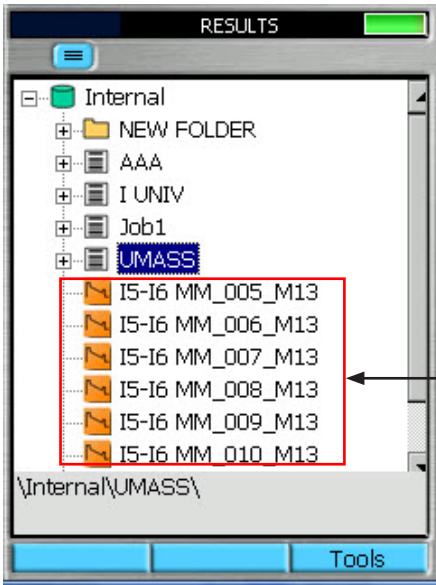

The v1.0.x (old User Interface) files are shown in the Main Menu under the last new file format Job in the Internal Drive; UMASS.

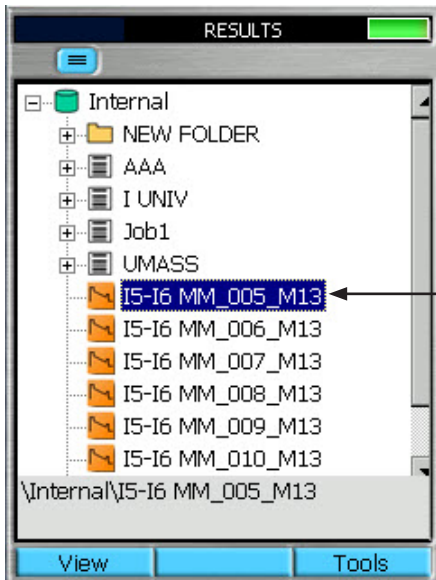

From the Results Manager:

- 1 Highlight the desired Old User Interface (UI) file.
- 2 Press [View] to open file for review or to convert to new User Interface (UI) v2.0.x file format.

Converting M200 old User Interface files into new file format

Old User Interface v1.0.x file opened for Viewing.
Trace file(s) open in Trace View with the [Read Only] label, located on top left.

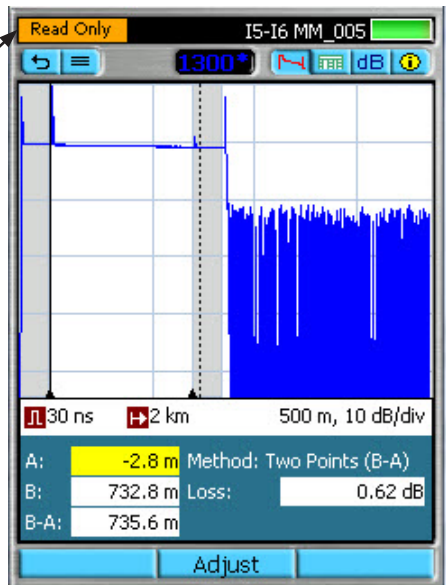

File conversion warning is generated when the user chooses to edit ('Re-Calc', 'Delete Evt' or 'Add Event') the v1.0.x Old UI Read Only file.

- Choosing 'Yes' opens a Convert window similar to the New Job Editor.
- Choosing 'No' returns the user to Read Only Trace View.

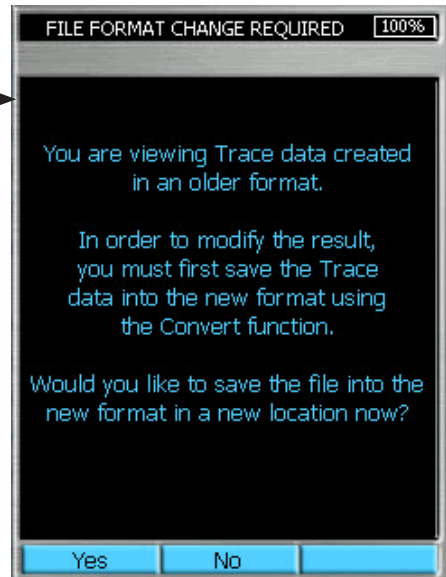

Converting M200 old User Interface files into new file format

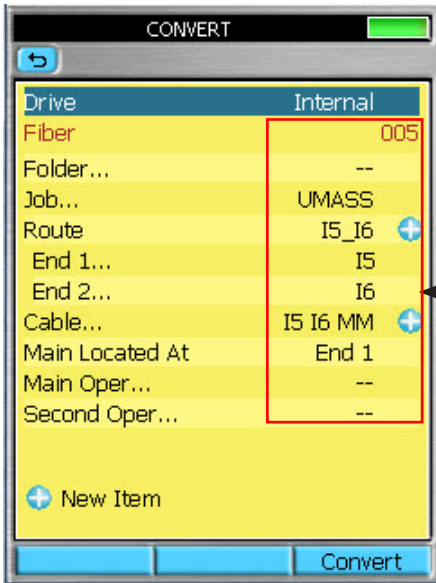

The Convert window is displayed if the user chooses to convert files.

The File fields are filled in with the information pulled from the .sor file:

- End 1 is filled in with Near Info
- End 2 is filled in with Far Info
- Cable is filled in with Cable information
- Fiber is filled in with the fiber number
- Job is filled in with the Job under which the files were dropped on the M200 which contained both v2.0.x and v1.0.x or earlier files.

Users may edit any field except the Fiber number to better identify the job using the new file format.

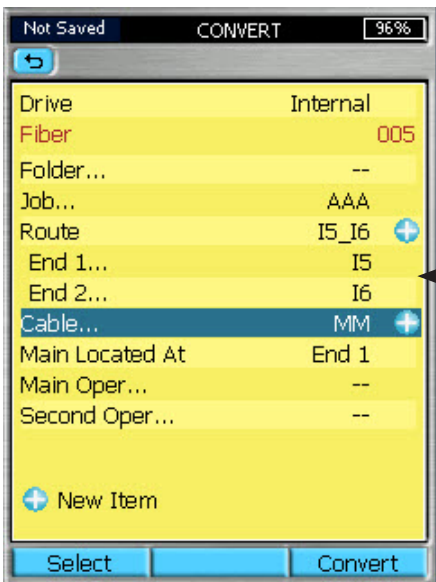

This screen shows an edit to the Cable string to reflect just the Cable Name and Job identified as AAA. Under the v1.0.x file format the file was saved as either Cable_fiber or Far_Fiber.

Press 'Convert' to change the file name and return to viewing/editing the OTDR trace file.

Note: Users frequently used the Cable field to completely identify the job, route and/or cable in v 1.0.x. In this instance I5_I6 is the route and is identified as the End 1_ End 2, Route per the new job construct.

Converting M200 old User Interface files into new file format

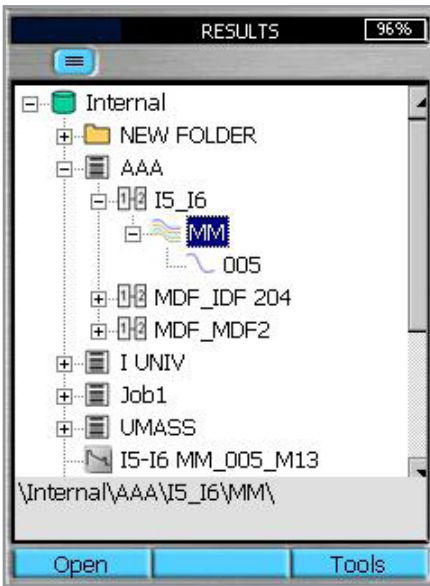

Results Manager screen image showing the Job created during the File Conversion from v1.0.x to v2.0.x.

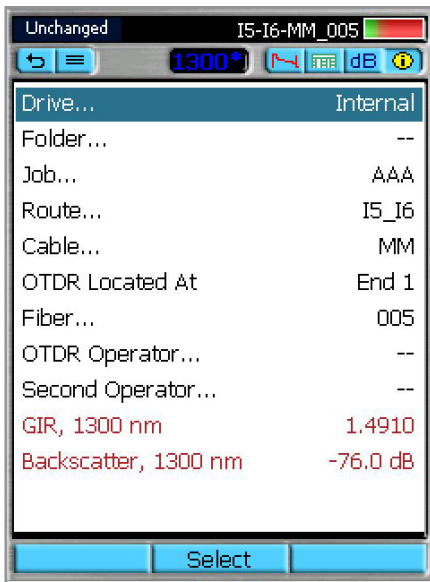

Job settings page now shows the file with the New v2.0 file format. Users may now edit ('Re-Calc', 'Delete Evt' or 'Add Event') and save changes to this file.

Converting M200 old User Interface files into new file format

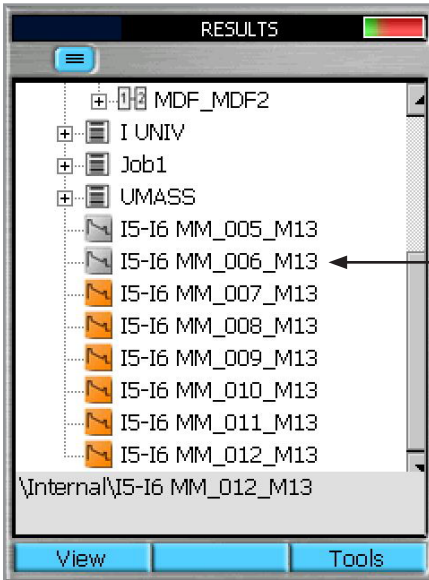

After converting a v1.0.x file, the Results Manager will show the old file greyed out in the v1.0.x file format as well as creating them in the new v2.0.x Job structure.

Running Tests & Viewing Results



Press  to start Test
OTDR header is **[Testing]**



Press  to stop Test
OTDR header is **[Stopping]** followed by **[Stopped]**



When test is done, the OTDR header is **[Not Saved]**







After test is saved, the OTDR header is **[Saved]**



Open saved trace from the Results Manager and use  keys to go between views without making changes. The OTDR header is **[Unchanged]**. If changes are made, the OTDR header is **[Not Saved]**.

Page Tabs (navigate using keys)

PAGE ICON	PAGE NAME	DESCRIPTION
	Trace page	Displays OTDR trace, setup, A/B cursor data, Loss Method, Loss, Reflectance, Test Settings (Range and Pulse Width) and graph scale
	Event Table	OTDR trace; event Location, Type, Reflectance, Loss, event Pass/Fail (if turned On)
	Summary page	Displays OTDR trace, Link Length, ORL (SM), Loss, link Pass/Fail (if turned On)
	Job Information page	Displays setup parameters of the currently displayed trace

Trace Page Features

M700 Series

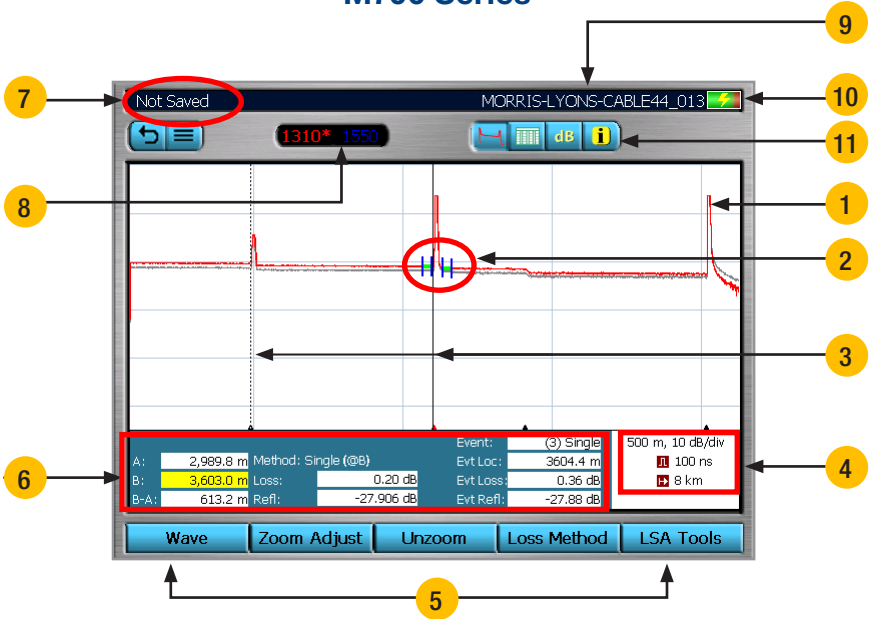



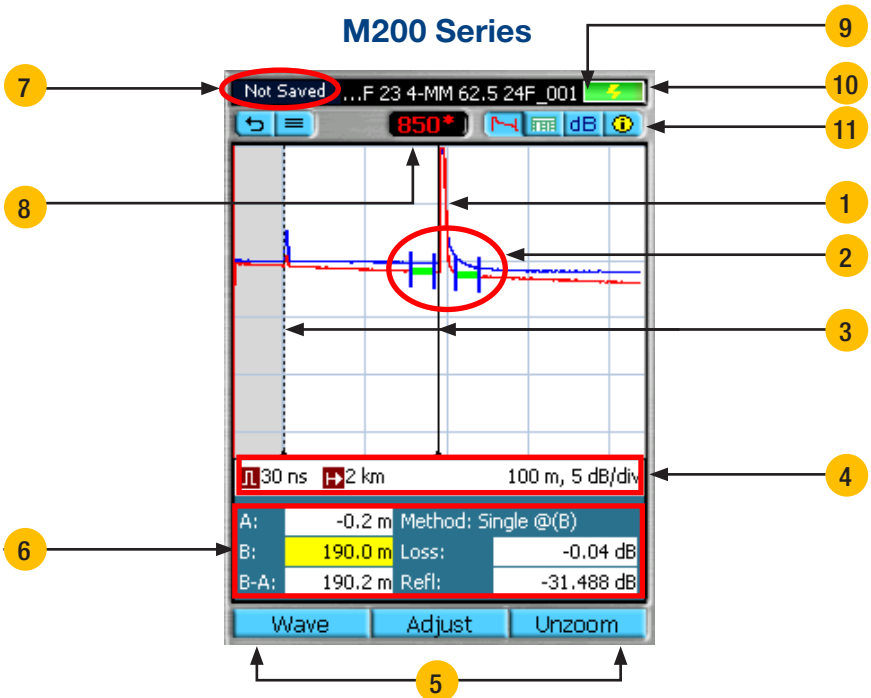



M200 Series











Trace Page Features



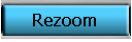









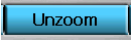
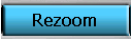

Trace Page Features

REF	FEATURE	DESCRIPTION
1	Trace	This is a graph of insertion loss vs. distance. The vertical axis shows loss in dB. The horizontal axis shows distance in user-selected distance units.
2	LSA adjust lines	Available depending on the selected Loss Method.
3	Cursors	Used to measure loss and distance. The active cursor can be moved by pressing ◀▶ arrows. Press the ⏪/⏩ key to toggle between the A and B cursors. Note: Active cursor is displayed as a bold line, inactive cursor is displayed as a dashed line.
4	Test settings data field	This field displays various test settings data as follows: distance • dB per division •  pulse width setting •  Range value
5	Soft function key labels	Soft function keys are located on the front panel. The label shown on the display above each key indicates the current use of each function key.
6	Test results field	This field displays various test results as follows: Loss Method, A and B cursor location, distance from A to B in user-selected distance units, measured loss and reflectance, and event data.
7	Test status	Displays test status labels as follows: Testing - indicates test in progress Stopped - test is interrupted Not Saved - the displayed test results are not saved Saved - the displayed test results are saved
8	Wavelength field	Displays test wavelengths of the currently displayed trace. For the dual-wavelength test, press the [Wave] soft key to toggle between test results. Note: the currently selected wavelength is marked with an [*].
9	File name field	Displays file name of the currently displayed trace.
10	Battery indicator	Displays estimated battery status as follows:  Green - fully charged  Red - discharged  Charging - AC connected  Fully Charged - AC connected
11	Trace page tabs	Select a tab to display the corresponding View (see page 25 for details)

Soft Keys - M700 Series

SOFT KEY	DESCRIPTION AND FUNCTION
	For the dual-wavelength test, press this key to toggle between the test results.
	<ul style="list-style-type: none"> Press this key to display the [Zoom Adjust] view. Use  arrows to adjust the Vertical zoom level. Use  arrows to adjust the Horizontal zoom level. When done, press OK to return to the Trace window.
 	<ul style="list-style-type: none"> Press [Unzoom] to display trace at the original magnification level. The soft key label changes to [Rezoom]. Press [Rezoom] to return to the previously set magnification level. The soft key label changes to [Unzoom].
	<ul style="list-style-type: none"> Press to display the Loss Method Menu. Use  arrows to select the desired Loss Method as follows: Two Point, Single, Multiple, Fiber Attenuation, Start, End.
	<ul style="list-style-type: none"> Press to display the LSA Tools Menu. Use  arrows to select the desired option as follows: LSA Adjust, Add Event, Reset Handles. When done, press the [OK] soft key to close the Loss Adjust Window.

Soft Keys - M200 Series

SOFT KEY	DESCRIPTION AND FUNCTION
	For the dual-wavelength test, press this key to toggle between the test results.
	Press this key to display Zoom/LSA sub-menu 
	<ul style="list-style-type: none"> Press this key to display the [Zoom Adjust] view. Use  arrows to adjust the Vertical zoom level. Use  arrows to adjust the Horizontal zoom level. When done, press OK to return to the Trace window.
 	<ul style="list-style-type: none"> Press [Unzoom] to display trace at the original magnification level. The soft key label changes to [Rezoom]. Press [Rezoom] to return to the previously set magnification level. The soft key label changes to [Unzoom].
   	<p>Press this key to display the [LSA Adjust] view. In the LSA Adjust screen</p> <ul style="list-style-type: none"> Press [Mode] to display the Loss Method Menu. Use  arrows to select the desired Loss Method as follows: Two Point, Single, Multiple, Fiber Attenuation, Start, End. Use -> keys. Press [Cursor] to toggle cursors. Press [Add Event] to add an event (not available in 'Two Point' test mode).
	<ul style="list-style-type: none"> Press to display the LSA Tools Menu. Use  arrows to select the desired option as follows: LSA Adjust, Add Event, Reset Handles. When done, press the [OK] soft key to close the Loss Adjust Window.

Event Table & Summary Results

Event Table & Summary Results are generated together

- 1 Set Mode to Full Auto or set Mode to Expert and Events (Event Settings) to Auto.
- 2 From the Event Table or Summary page, press the [Calc] soft key if no Event Table or Summary page was created. Or press the [Re-Calc] soft key to generate a new Event Table or Summary page if you desire to change GIR or BC found under [Fiber Type...] in the Re-Calc menu.

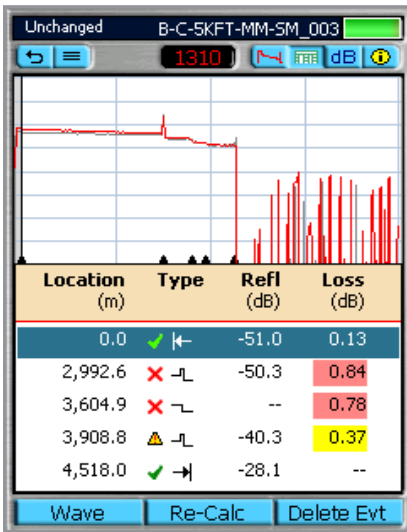

Shown with Pass/Fail Thresholds enabled

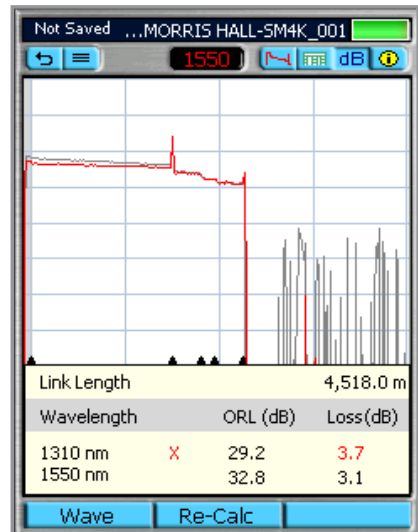

Shown with Pass/Fail Thresholds enabled

Event Icons and Types

EVENT ICON	EVENT TYPE
	Start of Fiber Under Test
	End of Fiber Under Test
	Reflective Event
	Non-Reflective Event
	Gainer
	Multiple Event

Fault Locating: Full Auto

- 1 Select Full Auto mode
- 2 Clean and Connect launch cable
- 3 Select Test Port: SM or MM
- 4 Select Fiber Type
- 5 Select Launch Cable: NOYES (1km), NOYES (500m), NOYES (150m), None, User
- 6 In General Settings: Set Distance Units: m, ft, kft, km, mi
- 7 Press Test key 

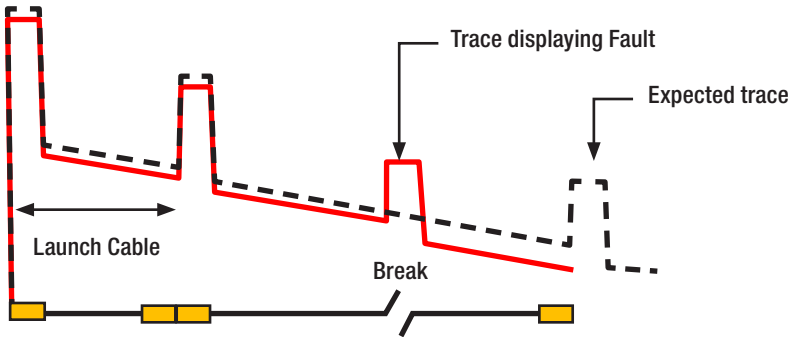

Two Point A/B Measurement

Measuring Loss on an OTDR Trace

An OTDR trace shows relative power vs. distance. The insertion loss (IL) between any two points (A to B) on the optical fiber link under test equals the trace level at A minus the trace level at B.

To measure the end-to-end loss of a link, use a launch and receive cable and put the [A] cursor before the first event in the link and the [B] cursor just after the tail of the last event.

cursor just after the tail of the last event.

- 1 Position the left cursor [A] at the start of the event
- 2 Position the right cursor [B] beyond the event where the trace returns to a constant slope
- 3 Read the insertion loss (Loss: in dB) measurement

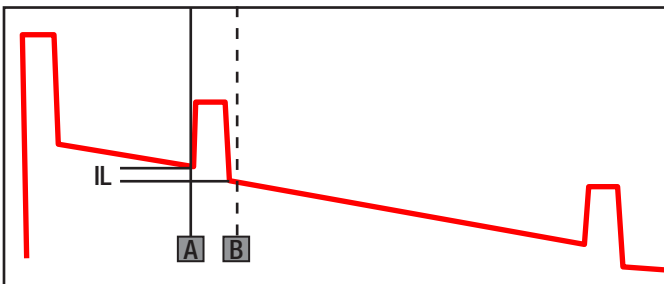

Shows IL of an event

Text Editor

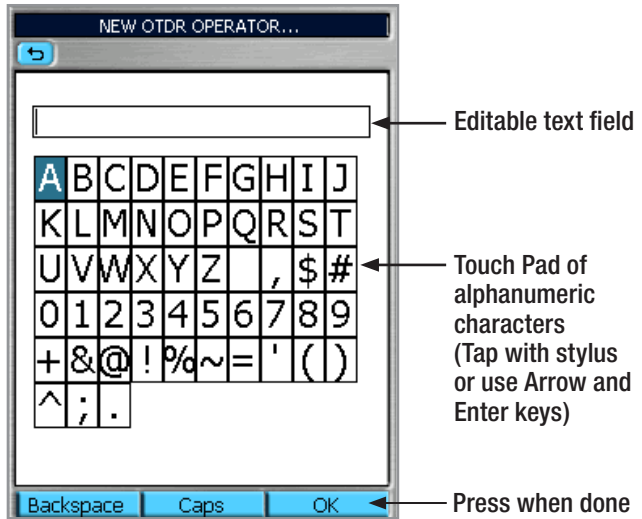

Soft key labels

Numerical Editor

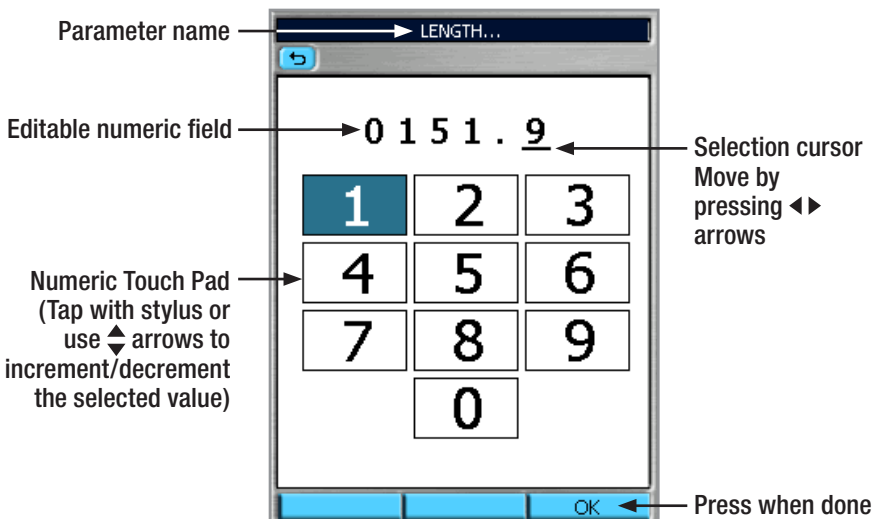

Transferring Files

From OTDR via USB Function Port to PC

To transfer files from your OTDR to a PC using a USB cable, perform the following:

- 1 Connect your OTDR to a PC using the supplied mini-USB to USB cable.
Note: If your PC requests new USB drivers, install the CD-ROM that comes with your OTDR, which contains the needed drivers. This step only needs to be performed the first time you connect your OTDR and PC together.
- 2 If your PC pops up a dialog box asking if you want to set up a new Partnership, select No (the OTDR should always be a 'guest').
 - Open My Computer > Mobile Device > File Storage > Internal folder.
or
 - Open My Computer > Mobile Device > USB folder.

Recommended Accessories

Fiber Optic Test Cables and Jumpers

Fiber optic test cables are necessary to connect an OTDR to the fiber under test (FUT). Test cables must have the same core and cladding size as the FUT. The connector at one end of the test cable must mate with the appropriate optical port on the OTDR. The connector on the other end must mate with the fiber optic link under test.

Launch and Receive cables are required to measure the insertion loss and reflectance of the near-end and far-end connectors respectively, of the fiber link being tested. NOYES Fiber Rings may be used as Launch and Receive cables. Fiber Rings with a variety of lengths and connector styles are available from AFL Telecommunications. The table on the next page will help in selecting the right test jumpers or cables for testing.

Fiber Optic Test Cables and Jumpers Selection Chart

TO DO THE FOLLOWING TEST	YOU WILL NEED THE FOLLOWING ACCESSORIES	
	To connect your OTDR to the fiber link under test	To terminate far-end of the fiber link under test
<ul style="list-style-type: none"> Fault locate - find a break Measure link length 	Test Jumper (1-2 m typical)	None
<ul style="list-style-type: none"> Measure near-end connector loss Measure near-end connector reflectance 	Launch cable (such as a NOYES 150m, 500m, 1000m Fiber Ring)	None
<ul style="list-style-type: none"> Measure near-end connector loss and reflectance Measure far-end connector loss and reflectance Measure end to end link loss and optical return loss 	Launch cable (such as a NOYES 150m, 500m, 1000m Fiber Ring)	Receive cable (such as a NOYES 150m, 500m, 1000m Fiber Ring)

Fiber Ring (FR) Selection Chart

FR LENGTH	FIBER TYPE	FIBER UNDER TEST LIMITS	COMMENTS
150m (492ft)	Multimode	All runs 30m to 3km or 2mi	Multimode runs are < 3km or 2mi
150m (492ft)	Single-mode	All P W's up to 1,000 ns or 1µs	* PW of 1µs = pulse length of 100m
500m (1,640ft)	Single-mode	All PW's up to 3,000ns or 3µs	PW of 3µs = pulse length of 300m
1km (3,281ft)	Single-mode	All PW's < 5,000ns or 5µs	PW of 5µs = pulse length of 500m
5km (16,405ft)	Single-mode	All PW's up to 20,000ns or 20µs	PW of 20µs = pulse length of 2km

* A PW of 1,000ns (1µs) requires reflective events lower than -45 dB of ORL to be used with the 150 meter fiber rings.

Cleaning Tips

Clean Test Cables and FUT

It is important to keep connector end-faces on the launch and receive cables and those on the Fiber Under Test (FUT) clean, to ensure accurate measurements and operation.

IMPORTANT! Inspect optical connectors after cleaning to ensure cleaning was successful and to verify the end-face is not damaged (cracked, pitted, etc.).

CAUTION! Never view a live fiber. Laser radiation is harmful to eyes.

Follow your company's approved cleaning procedures.

AFL recommends cleaning test cables using a Cletop cassette cleaner or a One-Click Cleaner.

Cleaning the Optical Ports

CAUTION! Before conducting the following procedures be sure to have the OTDR turned OFF.

Cleaning the OTDR and VFL optical ports without removing the adapters

AFL One-Click Cleaner method

- Remove the protective dust cover from the tip of the One-Click Cleaner.
- Insert the tip of the One-Click Cleaner into the optical port adapter and gently press the body of the One-Click Cleaner until an audible "click" is heard.
- Remove the One-Click Cleaner.

AFL FCC2 fluid and CCT stick method

- Lean a can of FCC2 back (30°), press the button on FCC2 to fill the well.
- Dip a CCT stick into the well of the FCC2 to dampen the tip with optical cleaning fluid.
- Place the damp tip over the ferrule to be cleaned.
- Rotate the tip clockwise 10 revolutions while applying varying pressure to create a gentle pumping action where the tip contacts the ferrule.
- Discard the CCT stick after using both tips.

Cleaning the optical ports with adapters removed

Removing connector adapters for cleaning and inspection

To access the OTDR Port

- Rotate the adapter base counterclockwise approximately four times.
- Pull the adapter directly out away from the universal adapter mount to expose the ferrule.

To access the VFL Port

- Unscrew the adapter counterclockwise and pull the adapter straight out to expose the ferrule.

To access the OPM Port

- Unscrew the adapter cap from the adapter cap mount.

Cleaning the Exposed Ferrule or the OPM port

Use lint-free optical cleaning wipes such as AFL FiberWipes and optical quality cleaning fluid such as AFL FCC2 connector cleaning fluid.

Note: if using isopropyl alcohol (IPA), be sure to use 99% pure IPA that has not been contaminated.

- 1 Dampen a portion of the wipe with the cleaning fluid.
- 2 Gently wipe the exposed ferrule (OPM port) starting with the wet section of the wipe and pulling it to the dry section.
 - **Note:** Starting with the wet cleaning and finishing in the dry improves cleaning action, reduces static buildup, and finishes with the end-face dry.

Cleaning the adapters

Method 1:

- 1 Insert a Cletop adapter cleaning stick into the sleeve of the adapter and rotate 10 times.
- 2 Remove.
- 3 After cleaning the adapter, replace the adapter over the ferrule; centering it onto the alignment pin.
- 4 Tighten the adapter base.

Method 2:

- 1 Use a can of filtered compressed air (held vertically), blow out any contaminants from the adapter.
- 2 After cleaning the adapter, replace the adapter over the ferrule; centering it onto the alignment pin.
- 3 Tighten the adapter base.

FAQs

Can I save traces for viewing later?

Yes. There is a dedicated **Save** key. In the Main Menu “File tab”, set up the location/folder (Internal or USB) to save the file, the file naming format, and fiber number. The fiber number will automatically increment after each trace is saved.

What is the advantage of the Expert Auto mode?

User is able to select a single λ and have the OTDR set the other test parameters.

What is the advantage of the Expert Auto Once mode?

User is able to select one or more wavelengths, let the OTDR select Pulse Width, Time, and Range for one test. Then allow the user to adjust any of these test parameters for the next test(s).

What is the purpose of the Real-Time mode?

With a launch cable, the Real-Time mode may be used to quickly view many short fiber links. It can also be used to quickly “trace” short fiber links.

Why do I need to use a launch and receive cable?

A launch cable allows the OTDR to settle down after the initial pulse and provides a reference cable for testing the first connector on the fiber under test. A receive cable provides a reference cable for testing the last connector of the fiber under test.

Tips: Expert OTDR Setup

RANGE: LENGTH

- Too Short: you will not capture the entire fiber length
- Too Long: trace will be squashed to left side of Screen
- Good Range: 1.5 to 2 times length of actual fiber

PULSE WIDTH:

- Too Narrow: trace disappears into noise floor before end of fiber is reached
- Too Wide: events can not be resolved
- Good Pulse Width: Events can be seen and trace is smooth

AVERAGES:

- Too Few: Trace is noisy, trace floor is too high
- Too Many: Trace is smooth but wastes time
- Good Number of Averages: smooth trace

Test in feet or meters?

If you know your fiber distances in feet, it may be beneficial to measure distances to events/faults in feet.

Fiber loss specifications are given in dB/km. Therefore it is often beneficial to measure fibers in meters/kilometers when loss results are required.

Recharging Batteries

The batteries may be charged while the OTDR is switched on or off by attaching an AC power adapter.

- Plug the AC adapter/charger into a standard wall outlet.
- Connect the AC adapter/charger to the Power port located on the OTDR side panel.
- The [AC/Charger] indicator on the front panel will turn on [Red].
- Charge batteries until the [AC/Charger] indicator turns [Green].

Note: an external battery charger and spare batteries are available

Repair and Calibration

AFL suggests that NOYES test equipment be calibrated every 12 months by an authorized NOYES calibration facility.

Annual calibration ensures that you are getting the most out of your equipment and that it is performing accurately. Many test standards also require annual calibration.

Authorized NOYES calibration facilities are ISO 9001 certified, traceable to the National Institute of Standards and Technology, and in compliance with ANSI/NCSL Z540-1, ISO 10012-1.

Please contact customer service for a return authorization number prior to sending your NOYES test equipment in for repair or calibration.

USA Repair and Calibration services

NOYES Test and Inspection Division

16 Eastgate Park Road

Belmont, NH 03220

603-528-7780

800-321-5298

Europe Repair and Calibration services

Fujikura Europe Ltd.

C51 Barwell Business Park

Leatherhead Road



Chessington, Surrey, KT9 2NY

+44 (0) 208 240 2020

Fujikura Europe Ltd. is an Authorized European Repair and Calibration facility for NOYES Test and Inspection products from AFL and should be contacted directly for service.

Software Information

View Version Information

- From the Settings Menu, use  arrows to highlight the [View Version Information...] parameter.
- Press  key to enter the Version Information Screen.

Note: It is helpful to have your OTDR version number if you need to contact Noyes Customer Service or Technical Support.

Software Updates

Please check our web site at www.AFLglobal.com/go/NOYES for software updates and additional application information. If you have any questions about your test equipment and recommended accessories, or if you need technical or sales support, please contact Noyes Customer Service.

Contact Us

You may call Noyes Customer Service between 8 AM and 5 PM, United States Eastern Time.

Phone 800-321-5298

603-528-7780

Fax 603-528-2025

Mail NoyesTechSupport@AFLglobal.com

Thank you for choosing NOYES Test and Inspection



www.AFLglobal.com/go/NOYES