

DOCUMENT RESUME

ED 104 674

SE 018 828

AUTHOR Daifuku, Hiroshi; And Others
 TITLE Temporary and Travelling Exhibitions. Museums and Monuments, X.
 INSTITUTION United Nations Educational, Scientific, and Cultural Organization, Paris (France).
 PUB DATE 63
 NOTE 166p.; Some photographs referenced in the text may not reproduce clearly
 AVAILABLE FROM UNIPUB, Inc., P.O. Box 443, New York, NY 10016 (no current price quoted)

EDRS PRICE MF-\$0.76 HC Not Available from EDRS.. PLUS POSTAGE
 DESCRIPTORS Arts Centers; *Educational Facilities; Environmental Education; *Exhibits; Facilities; *Guides; Manuals; *Museums; *Program Development; Program Planning; Science Education; Science Materials; Social Sciences; Social Studies

IDENTIFIERS UNESCO

ABSTRACT

The permanent exhibition, the most typical form of museum exhibition, has failed to attract repeated visitation, since visitors quickly become familiar with the objects shown. The temporary exhibition evolved as a result for the need of repeated visitation. The temporary exhibition, set up for a period of one to six months, introduces fresh material to the visitor and stimulates his interest. Moreover, it frequently causes him to revisit the permanent exhibition which contains the museum's main assets. This manual, consisting of seven chapters, deals with the temporary exhibit and traveling exhibit. Part I, the Temporary Exhibit, includes three chapters: The Temporary Exhibit in Science Museums, which deals with designing, staff planning, lighting, sound, etc.; Temporary Exhibits in Art Museums, which considers methods, visitors, catalogues, guides, and talks; and Exhibits in the Technically Underdeveloped Countries, which discusses program types. Part II, Traveling Exhibitions, contains the following four chapters: Chapter IV deals with the origin, sources, costs, supervision, assembly, display, and other topics related to traveling exhibits; Chapter V discusses principles of packing; followed by Chapter VI, transportation. Chapter VII, the final chapter, considers insurance policies. An introduction, bibliography and three appendices are also included. (Author/TK)

U.S. DEPARTMENT OF HEALTH,
EDUCATION & WELFARE
NATIONAL INSTITUTE OF
EDUCATION

THIS DOCUMENT HAS BEEN REPRO-
DUCED EXACTLY AS RECEIVED FROM
THE PERSON OR ORGANIZATION ORIGIN-
ATING IT. POINTS OF VIEW OR OPINIONS
STATED DO NOT NECESSARILY REPRE-
SENT OFFICIAL NATIONAL INSTITUTE OF
EDUCATION POSITION OR POLICY.

museums and monuments - x

temporary and travelling exhibitions

ED104674

REPRODUCTION OF THIS DOCUMENT BY
ANY OTHER MATERIAL BY MICRO-
FICHE ONLY HAS BEEN GRANTED BY

Edward Wegman

UNESCO

AND PROMOTION OF THE
INTERESTS OF THE
EDUCATIONAL
REPRODUCTION OF THIS
DOCUMENT BY ANY OTHER
MATERIAL BY MICRO-
FICHE ONLY HAS BEEN GRANTED BY

unesco

MUSEUMS AND MONUMENTS - X

F

Unesco has also published the following titles of interest to the readers of this book:

- I. *Sites and monuments: problems of today.* 100 pages, 115 illustrations, plans, index, 2nd ed., 1953 (bilingual).
- II. *The care of paintings.* 164 pages, 87 illustrations, diagrams, index, 2nd ed., 1952 (bilingual).
- III. *Cuzco: reconstruction of the town and restoration of its monuments.* 58 pages, 64 illustrations and maps, 1952 (also in French and Spanish).
- IV. *Saint Sophia of Ochrída: preservation and restoration of the building and its frescoes.* 28 pages, 37 illustrations and maps, 1953 (also in French).
- V. *Manual of travelling exhibitions.* 112 pages, 18 diagrams, 70 illustrations, 1953 (also in French).
- VI. *Lebanon: suggestions for the plan of Tripoli and for the surroundings of the Baalbek Acropolis.* 48 pages; 1 map, 7 diagrams, 44 illustrations, 1954 (also in French).
- VII. *Syria: problems of preservation and presentation of sites and monuments.* 52 pages, 61 illustrations, 3 maps, 1954 (also in French and Arabic).
- VIII. *Protection of cultural property in the event of armed conflict* (revised and enlarged from the French text). 346 pages, 124 figures, 137 illustrations, 1958 (also in French).
- IX. *The organization of museums: practical advice.* 188 pages, 18 figures, 8 tables, 91 illustrations, 1960 (also in French).

TEMPORARY AND TRAVELLING EXHIBITIONS

UNESCO

5

*Published in 1963 by the United Nations
Educational, Scientific and Cultural Organization
place de Fontenoy, Paris-7^e
Printed by Hang-Druck, Düsseldorf, Germany*

© Unesco 1963
Printed in Germany
C.U.A.62/X.10/A

CONTENTS

Foreword	9
The authors	11

PART ONE

TEMPORARY EXHIBITIONS

CHAPTER I. THE TEMPORARY EXHIBIT IN SCIENCE MUSEUMS

by Lothar P. Witteborg

Introduction	15
Designing exhibitions	15
Staff for exhibitions	16
Planning an exhibition	16
Use of a model in preparatory work	17
Label design	23
Preparation of labels	24
Lighting	25
Animation	28
Films and slides	28
Sound	28
Bibliography	29

CHAPTER II. TEMPORARY EXHIBITIONS IN ART MUSEUMS

by H. L. C. Jaffé

Introduction	30
Principles and methods	30
The visitor	31
Emphasis on original objects	31
Avoidance of distractions	32
Catalogues and brochures	33
Guides and talks	33
Assembling an exhibition	33
Themes for small or medium-sized museums	34
Local arts and crafts	34

Local history	34
Biographical exhibitions	35
Selection of material	36
Principles of display	36
Space requirements	36
Circulation of visitors	37
Accents in an exhibition,	38
The layout	38
Arranging the order of objects on display	39
Technical and practical problems	40
Wall space	40
Panels or partitions	40
Showcases	41
Lighting	41
Labels	41
Precautions to keep in mind	42
Conclusion	43

CHAPTER III. EXHIBITIONS IN THE TECHNICALLY
UNDERDEVELOPED COUNTRIES

by Hiroshi Daifuku

Introduction	44
The visiting public	44
Programmes for temporary and travelling exhibitions	45
Ethnographic and historic exhibitions	45
Exhibitions on cultural problems	46
Industrial and technological exhibitions	47
Exhibitions on health problems	47
Natural history exhibitions	47
Preparing temporary or travelling exhibitions	48
Educational programmes	49
General discussion	50
Bibliography	51

PART TWO

TRAVELLING EXHIBITIONS

Foreword to the revised edition, by Grace L. McCann Morley	55
Foreword to the first edition (1953) of the <i>Manual of Travelling Exhibitions</i> , by Grace L. McCann Morley	56

CHAPTER IV. TRAVELLING EXHIBITIONS

by E. C. Osborn (revised by Grace L. McCann Morley)

Introduction	58
The origins of travelling exhibitions	60
Sources of travelling exhibitions	60

Costs	61
Circulating an exhibition	62
Supervision of tour	62
Schedule sheet	63
Exhibition contract	64
Mailing forms and instructions	64
Supplementary information	64
Labels	64
Publicity	64
Catalogues	65
Assembly and display	65
Paintings	66
Watercolours, drawings, prints, photographs, or other works on paper	66
Unmounted material	67
Protecting matted prints	67
Mounting several prints on a mat	68
Sealed airtight mounting	68
Mounting photographs	68
Sculpture	68
Textiles and costumes	72
Three-dimensional objects	72
Wall panels	72
Demountable tables	72
Demountable cases or wall-cases	72
Demountable installation units	75
Glass cases	75
Books	75
Posters	75
Unique and valuable examples of poster art	75
Replaceable contemporary posters	75
Furniture	76
Architecture and civic planning	76
Panels and free-standing display units	76

CHAPTER V. PRINCIPLES OF PACKING

Introduction	80
General rules	80
Cases	80
Construction	80
Cover attachment	81
Waterproofing	81
Interior partitions	81
Size	81
Padding and wrapping	81
Pictures covered with glass	86
Condition of objects	86
Marking cases	87
Replacing packing materials	87

Special instructions	87
Paintings	87
Oils, temperas, etc.	87
Pads and separation sheets	89
Packages	89
Envelopes or inner cases	93
Cases with fitted grooves for pictures	93
Trays	93
Framed watercolours, drawings, prints, photographs	94
Pastels	94
Miniatures: ivories, woods, etc.	94
Small fragile objects	94
Small non-fragile objects	95
Works on paper	95
Books	96
Textiles	96
Large objects	97
Sculpture	97
Furniture	98
Architectural models, stage settings, etc.	98
Panels	98
Museum exhibitions other than art	99
CHAPTER VI. TRANSPORTATION	
Shipments by truck	100
Shipments by rail	101
Ocean transport	102
Air transport	103
CHAPTER VII. INSURANCE	
Type of policy	105
'Bailee' liability insurance	106
Establishing values and settlements	106
Declared valuations	106
Carrier insurance	107
Reports to insurers	107
Air freight insurance	107
Ocean freight insurance	107
Exclusions from general 'floater' policy	108
Bibliography	110
APPENDICES	
I. Examples of forms sent out with travelling exhibitions	111
II. General rules for handling travelling exhibitions	117
III. Sample insurance policy for fine arts coverage	121
Illustrations	125

The Organization of Museums: practical advice (Museums and Monuments Series, IX) was published in 1960, as part of a long-term programme for the preparation of technical manuals to meet the needs of smaller museums and of institutions located in areas where museums are rare.

It should not be forgotten that museums began as the collections of wealthy individuals or groups, and that they were based upon the premise that these collections were for the enjoyment and edification of a select few. This remained true even of State collections during the last century. Curators placed in charge of the collections thus began their tasks as individuals having primarily academic or scientific training.

During the past fifty years, however, increasing emphasis has been given to the doctrine that collections shown in museums could be appreciated by the general public, a phenomenon which accompanies the growth of public education programmes throughout the world. It was soon realized, however, that the simple placing of objects on exhibition was not sufficient and that explanatory devices and some coherence in presentation were necessary if the average visitor was to derive any intellectual or aesthetic benefit. Permanent exhibitions were accordingly modified over the course of years and curators became familiar with such factors as 'fatigue', traffic patterns, labels pro and con, background colours, lighting effects, etc.

However, even after the permanent exhibitions had been modified to suit the requirements of the public, and as the public in turn became familiar with the objects shown (particularly the smaller collections in r

lized and small institutions) the number of visitors to a given institution inevitably declined.

As museums depend increasingly today upon public support, including government support, it soon became evident that steps should be taken to encourage regular, repeated visits to museums. The temporary exhibition was a result of this need, and since the Second World War has become an increasingly important element in every active museum's programme. The temporary exhibition, set up for a period of one to six months, introduces fresh material to the visitor and stimulates his interest. Moreover, it frequently causes him to revisit the permanent exhibition which contains the museum's main assets. There have also resulted a number of secondary benefits: the curatorial staff has become increasingly conscious of the necessity for coherent presentation, has experimented more freely with theatrical effects, and has evolved a range of exhibition furniture. Many of the lessons learnt have had a salutary effect upon the preparation or modernization of permanent exhibitions.

Another important result has been the exchange of objects between museums for purposes of temporary exhibition; such co-operation now takes place not only on a national, but also on an international scale. In addition there also exist complete, permanent travelling exhibitions prepared by museums, institutions and agencies, and even by governments. Hence the cultural benefit is expanding steadily and communities are becoming increasingly conscious of the cultural achievements of other peoples. Lastly, packaging techniques have been developed for fragile and often irreplaceable objects

and through the publication of Unesco's *Manual of Travelling Exhibitions*¹ these techniques were widely diffused.

The present manual, entitled *Temporary and Travelling Exhibitions*, is published to meet the need for a text on these problems. In the section on temporary exhibitions, three chapters deal with science and art museums as well as with the possible utility of temporary exhibitions in countries which are undergoing rapid social and cultural change. The section on travelling exhibitions is a revision of the original 1953 manual and includes new material and techniques developed since it was issued.

Every effort has been made by the authors to emphasize general principles which are widely followed; any opinions expressed are, however, those of the authors and not necessarily those of Unesco.

The Secretariat wishes to express appreciation of the co-operation given in the preparation of this manual by the different contributors: the Unesco/ICOM Museographical Documentation Centre; the Victoria and Albert Museum, London; the National Museum of Wales, Cardiff; the American Museum of Natural History, New York; and the various institutions, too numerous to mention, which have contributed photographs and other documentary material to the Unesco/ICOM Museographical Documentation Centre.

1. Elodie C. Osborn, *Manual of Travelling Exhibitions*, Paris, Unesco, 1953. (Museums and Monuments series, V.) (Out of print.)

THE AUTHORS

DAIFUKU, Hiroshi

Ph.D. (Harvard). Instructor, Department of Anthropology, University of Wisconsin (1949-52). Curator of anthropological exhibitions, State Historical Society Museum of Wisconsin (1952-54). Programme Specialist, Museums and Monuments Division, Unesco, since 1954. Publications on anthropology and museography.

JAFFE, Hans L. C.

Ph.D. (University of Amsterdam). Assistant, Municipal Museums of Amsterdam (1935). Monuments, Fine Arts and Archives Officer, Royal Dutch Army (1944-47). Curator, Municipal Museums (1947-52). Assistant Director (1952-61). Lecturer on Modern Art, University of Amsterdam, since 1958. President of the Dutch Section of the International Association of Art Critics and International Vice-President. Publications on modern art and museography.

MORLEY, Grace McCann L.

D.-es-L., (University of Paris). LL.D., *Honoris Causa* (Mills College and University of California). Curator, Cincinnati Art Museum (1930-33). Director, San Francisco Art Museum (1935-60). Head, Museums Division, Unesco (1947-49). Director, National Museum, New Delhi, India, since 1960. Director, Unesco International Semi-

nar on Museums, Athens, Greece (1958). Publications on art and museography.

OSBORN, Elodie Courter

B.A. (Wellesley College). Graduate studies in art history, New York University (1934-36). Joined the staff of the Museum of Modern Art in 1933 and became Secretary of Travelling Exhibitions (1933) and Director of the Travelling Exhibitions Service (1939-47). Editor of *Texture and Pattern* and *Modern Sculpture* (Museum of Modern Art, 1947-49); author of *Manual of Travelling Exhibitions* (Unesco, 1953). Secretary, School Building Committee, Salisbury Central School (1950-54); Founder and President, Salisbury Film Society (1951); Vice-President, American Federation of Film Societies (1957-58); Vice-President, Salisbury Health Center (1961-62).

WITTEBORG, Lothar P.

M.A. (University of Michigan). Instructor, Department of Anthropology, Florida State University and Curator in the University Museum (1951-52). Curator, Newark Museum (1952-54). Chief, Exhibition Department, American Museum of Natural History, New York (1954-60). Free-lance consultant in museology and visual communication since 1960, advising on the design of a new State Museum in New Jersey, etc. Has undertaken missions to India (1958-59), Malaya (1960), etc. Publications on exhibit design.

PART ONE

TEMPORARY EXHIBITIONS

THE TEMPORARY EXHIBIT IN SCIENCE MUSEUMS

by Lothar P. WITTEBORG

INTRODUCTION

The vast majority of museums still believe in the primary importance of their traditional function as storehouses of objects and institutions of research, and few of them have laid stress on the interpretation of their collections through exhibitions, and specifically temporary exhibitions. One often hears the excuse that temporary exhibitions tax the budget and the permanent staff's time so severely that they interfere with permanent exhibits, maintenance, research and other normal activities of a museum.

However, some museums have learned to solve the problems of tight budgets, small staff, inadequate storage area and exhibition space by stressing temporary and changing exhibitions. Not only do they thus avoid huge expenditure on permanent installations and overcome the general problem of lack of space, but they find added zest in meeting their obligations to the public by presenting timely exhibitions installed in a flexible modular exhibit system. Thus, in rotation, the museum is able to show more of its permanent collections in a smaller space and the visitor to receive fresh stimulation from a changing series of new exhibits. This approach is finding many adherents among newly constructed museums, for maximum flexibility offers great functional advantages and in the long run saves both money and space. It may cost almost as much to design and construct good modular exhibition equipment, including cases and panels, as permanent exhibition equipment, but the flexible units can be used again and again.

Whether a museum exhibit is permanent or temporary, its main objective should be to

communicate ideas, facts or concepts by visual means, not merely to present objects in a pleasing arrangement.

DESIGNING EXHIBITIONS

The success of an exhibit depends chiefly on the quality of its design and, above all, the concept to be illustrated or the story to be told. But an exhibition does not in fact exist without its visiting public, and what really matters is how the visitors react to what they see. Whether the captive museum audience can be satisfied depends both on the visitor himself and on the techniques of presentation used. It is their dramatic quality and their difference from the everyday world that make exhibits memorable. Over the past years the trend in exhibition design towards clean and simple shapes has led to a dramatic and more direct method of presentation. In addition to architectural effects, graphic design, painting, photography, and the applied arts and crafts have had a marked influence on exhibition design. The combination of simple structure and well-thought-out colour schemes is one of the strongest response-producing techniques at the disposal of the designer. Colour, form and lighting can be used to guide the visitor along a predetermined path and empty space turned to advantage to afford a visual rest, a matter of extreme importance in larger museums. Colour and lighting can also be used to dramatize an important part of the story, and where the immediate purpose is the transmission of concepts and facts, ideas can be communicated by visual symbols, i.e., colours and forms used as substitutes for

words. No concept or theory is too difficult to interpret to an uninitiated mind of any age, provided it is elucidated in terms of the viewer's experience. Design, in its proper place, used with taste and technical skill, acts as a subtle persuader of public interest and attention.

Exhibitions on a single theme are a relatively new departure both in the long history of museums and in commercial display, and they offer great scope for experimentation and development. Enormous possibilities lie ahead in the field of visual communication, not so much in layout, structure and display arrangement as in the controlled application of techniques of sound, animation, colour and lighting. Architecture and display arrangement help to focus attention on the exhibits, but they should never be allowed to monopolize interest. Exhibition design is an empirical process, and there is no one infallible answer to any problem. Some of the problems of visual communication met by the exhibition designer could be overcome if a standardized psychological testing device could be developed to anticipate visitor response and information retention. But before such aids are available experimentation on a large scale will have to be undertaken. And, of course, successful exhibition design can never be merely a matter of applying formulae.

STAFF FOR EXHIBITIONS

Since trained museum specialists are rare among the staff of the smaller museums, where possible, advice and help should be sought from the nearest college or university. The small museum and the university can co-operate to their mutual benefit and that of the community.

Little of the available museum literature deals with the problems of visual communication, i.e., the conception, planning, design, construction and final installation of exhibits. I hope that the short bibliography given at the end of this chapter may stimulate new thought concerning this most challenging aspect of museum work.

PLANNING AN EXHIBITION

Let us assume that a set sum is available for

a new exhibition hall for temporary exhibitions where flexibility and changeability will be essential requirements. How ought we to approach the problem of designing a modular exhibit unit appropriate for the first planned exhibit assigned to the new gallery, which will also be suitable for future still unplanned exhibits? The primary considerations will be the budget, the availability of materials, i.e., metal, glass, plastic, etc., and also of competent craftsmen. Money must be set aside for the contents, preparation and installation of the first exhibition.

Let us assume that the new gallery is to be opened in a health museum that is already in operation and has a small staff and a limited budget. The contents of the first exhibit will deal with the biology of man, a general physiological survey. Future exhibits will deal with more detailed aspects of the human body, its function in health and illness, and other exhibits of special current interest. Taking into consideration the space available in the new gallery and the estimated average attendance, including guided tours, the planners must now arrange the exhibit space. If the exhibition has a particular message, the only way to make sure that the visitor sees everything and in the right order is by controlled circulation. This means quite simply that people are not offered a choice of routes round the display but are unobtrusively directed along the correct path. Baffles and screens can restrict the area seen at any one time so that the viewer is able to concentrate on independent groups of logically related objects.

After a content outline or exhibit story has been prepared and the types of exhibits to be used have been selected, i.e., specimens, models, photographs, charts and diagrams, the exhibit is laid out in a logical progression according to the outline and space is allocated on a plan drawing of the gallery. Thought must also be given to future needs which can sometimes be provided for in the design of the units. We now have, on a plan drawing, a story outline, a visitor flow pattern and a rough idea where various parts of the exhibit will appear. Many arrangements, rearrangements and drawings will undoubtedly have to be made before a clear, simple solution is reached for the final arrangement of the exhibit.

Now, with the assistance of an architect, staff designer, or exhibit consultant, flexible modular exhibition furniture and the exhibit itself can be planned. In any exhibition, of whatever nature or size, the third dimension is the essential element, and for this reason the most direct approach to the conception and planning of exhibitions is to work first with scale models, and then to experiment with the actual materials to be shown in order to find the best spatial relationships for the finished exhibition.

USE OF A MODEL IN PREPARATORY WORK

For the exhibition designer, working in three dimensions represents a method of visualization. Merely by creating an illusion of the exhibition space on a miniature scale and with a human figure in proportion, his imagination is set to work in three-dimensional terms (Plate 7). Concepts and ideas for design will occur to him which would not result from working with two-dimensional layouts on paper. Spatial relationships will suggest themselves: the placing of an object in the foreground or in the background, grouping, etc. Possibilities of using such devices as a revolving drum to carry information or a large informative photo, mural or drawing as a background for a model or specimen will come to mind. In these and in many other ways the final design is formulated in the proper medium of the exhibition space itself.

The model, then, is a medium of creative visualization for the designer, and it is an equally important tool for those planning the exhibition. The curator who has undertaken the background research and selected the material can by this means grasp the possibilities and the limitations of the facilities at his command. He will be able to check the effectiveness of his choice of material, view it from the point of view of the spectator trying to understand the sequence and development of the subject, and weigh visually the impact of the various elements almost as if he were actually confronted with them.

In the early planning stages, the usefulness of a model is in almost inverse proportion to the amount of detail included. This is a tool in the development of a plan, and as such

need not be worked out in detail. Four pieces of cardboard become a room and even the crudest stick placed inside to represent a human figure will suffice. It is advisable at this stage to work on a very small scale. This preliminary planning is essential, whether the exhibition is to occupy a large hall, a temporary, free-standing display unit, or a single wall-case. It permits the relationships between the major divisions of the subject to be seen as a whole; the constituent elements of these divisions need not be considered in detail at this stage.

When larger exhibitions are being planned it may be necessary to work on a larger scale, particularly when a great deal of information is to be transmitted and co-ordinated use of labels, diagrams, models and specimens is required. A scale of one-fourth actual size will suggest sufficient detail to provide a sound basis for planning. It is advisable to prepare complicated panels or cases in full scale.

The preliminary design model is a means of trying out ideas. Alternative positions of specimens in a case, or of cases and free-standing panels, can be tested quickly and easily. New possibilities can be examined, and the manipulation of scale exhibition furniture can lead to the discovery of new ways of exploiting the available space. Everything must be considered in relation to the eye and the position of the viewer, the distance at which the object will be seen first, and where the viewer will stand for close inspection. The designer, knowing that visitors will be standing, should design for viewing at eye level: about 5 ft. 3 in. for Europeans and Americans and 5 ft. for Asians.

To return to our design for the Biology of Man exhibition: we must decide whether the display is to be primarily two-dimensional, i.e., a panel exhibit with photographs, charts and diagrams, or a three-dimensional exhibit with many specimens, models and reconstructions in addition to the two-dimensional elements. The deciding factors will be the budget and the availability of specimens, models or a staff model-maker. Let us assume that the exhibit will be primarily two-dimensional, but will include some specimens and models. This will determine the choice of exhibit structure:

either a free-standing panel system or a wall panel system with a few cases to house the specimens and models. The possibilities of design and construction are limitless. Expensive materials like aluminium, steel and plastic can be used (Figs. 1 and 2, Plates 2a and b), but, where economy is important, plumbing pipe, wood and glass (Figs. 3 and 4, Plates 6 and 7), which are found everywhere and are usually inexpensive, are also suitable. Now, with our story outline, visitor flow pattern and scale model of the hall, as well as designs for a flexible exhibit unit of panels and cases, we can finally design the first exhibition.

The over-all design may have to be altered at various stages in the construction of the panels and cases, depending on the specific requirements for exhibition of the objects selected. In some instances, the design of certain parts of the exhibit may have to be worked out in some detail before even a rough judgement can be reached as to its general form or size in relation to the rest of the exhibit. It may be necessary to make a full scale mock-up of a panel or case in order to judge its effectiveness in illustrating the particular theme. By working with three-dimensional models, problems of how to make clear the relationship of the various parts of a complex explanation can be solved by experimenting with position, colour association, or structural connection. However, the general design is always the overriding consideration and must be constantly referred to. The location of each case or panel in the exhibition as a whole must be decided in terms of size, colour, form and material, and here again the scale model is a valuable aid.

While the design of the exhibit is being worked out the curator should keep in mind the accompanying explanatory labels.¹ If the exhibit has been well planned with a clear over-all objective and the curator has thought out his story in visual terms, the welding of all the various elements into a comprehensive whole can be effectively achieved with a minimum of captions and labels (Plate 3). Good exhibition depends on clear visualization of ideas rather than the logical structure of scripts or story outlines. When the story is submitted to the designer, it should be accompanied by rough label

copy. Too often the labels are written after the exhibit design is complete, and it is then discovered that much information will have to be added for the sake of continuity or by way of explanation. An exhibition which is no more than a textbook illustrated with a few three-dimensional objects is not attractive to the museum visitor, but the opposite extreme, the exhibition with hardly any labels, is equally unsatisfactory. All too frequently in many of our art museums, an archaeological ceramic specimen may be identified merely as 'ceramic vessel with handle'. Words should nevertheless be kept to a minimum and the best way to communicate the exhibition's message is by memorable visual images.

Successful visual communication in an exhibit demands that all the elements—design, technical preparation, labels and installation—form a unified whole. After an initial visual impression has been made by the most obvious components of the exhibit, i.e., form, colour and light, the communication of general information depends upon the integration of the various elements used to illustrate the subject—specimens, photographs, reconstructions, models, etc. The basic information is communicated through titles, sub-headings and labels, which should be designed to harmonize with the atmosphere created.

The most difficult problem is perhaps the writing of the actual text of the label; should it be addressed to a mass audience or to a public of a particular educational level? This question is partially answered in the case of specialized museums such as children's museums or university museums, but for most museums the question of label comprehension presents an extremely difficult problem to which there is no definite solution. Obviously, no single style of label can arouse interest at all educational levels. Attempts have been made to overcome this problem by completely eliminating labels, or by supplementing the detailed label by a

1. I am greatly indebted to Mr. Alex Williams who has given me permission to use much of his material on labels. See A. Williams, 'Labels. Writing, Design and Preparation,' *Curator*, New York, 1960, Vol. III, No. 1, p. 26-42.

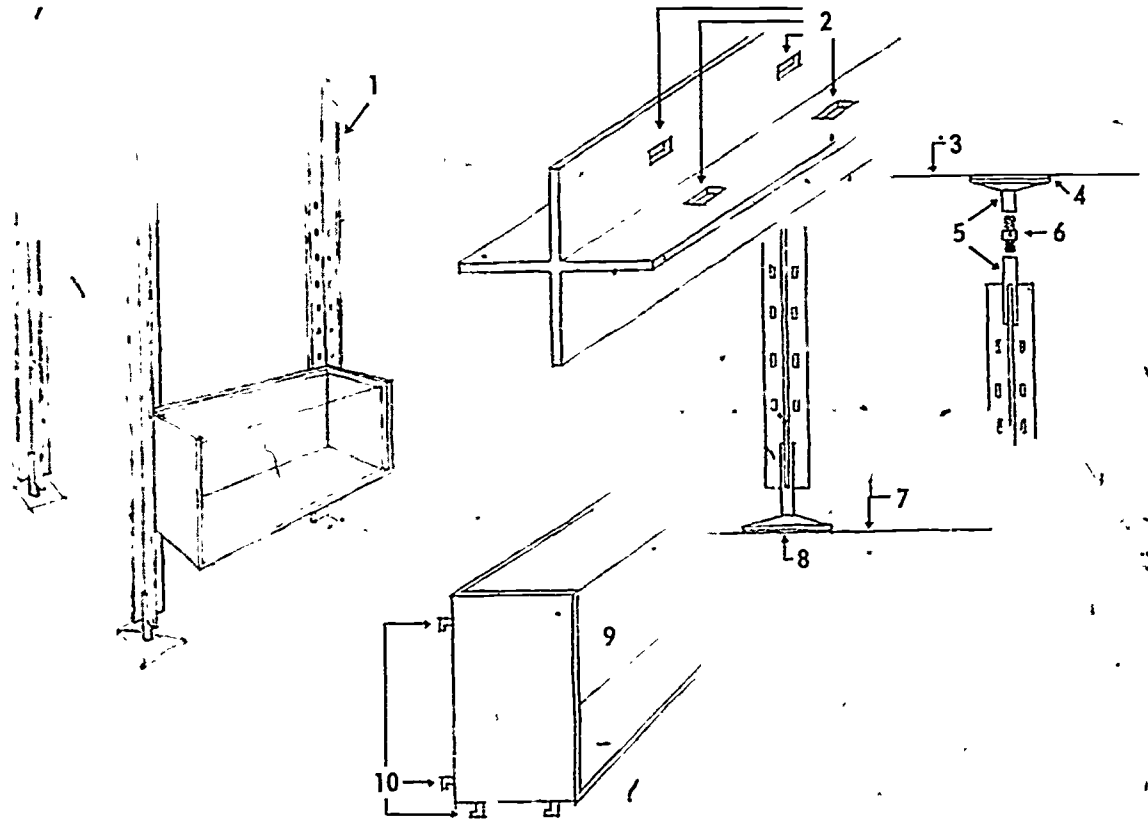

Fig. 1. Adjustable case mounting. 1, anodized aluminium poles, 2, notches to receive cases, panels and shelves; 3, ceiling; 4, foam rubber, 5, threaded aluminium pipe; 6, screw jack; 7, floor; 8, double-faced industrial tape to prevent movement, 9, case with wooden back, floor and two sides (glass slides into notched grooves), 10, hooks for attachment to vertical poles. Case can be hung horizontally or vertically.

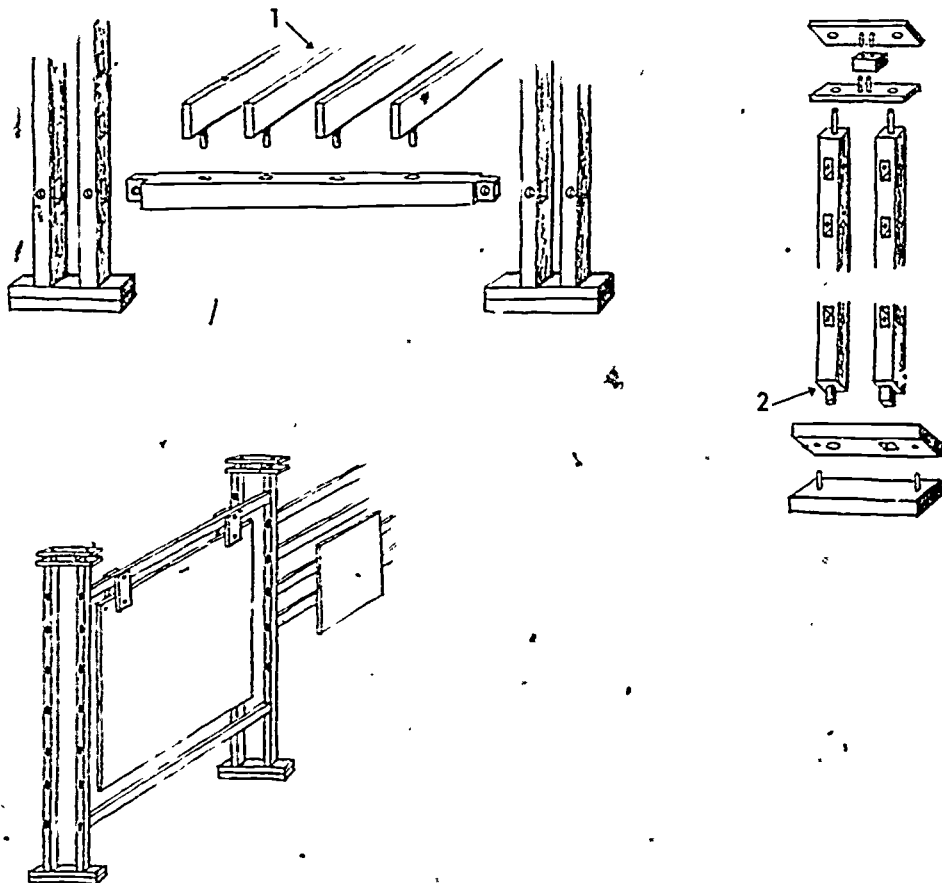

Fig. 2. Vertical H system using a wooden framework, many combinations are possible with this system. 1, platform; 2, this pole can rotate.

7

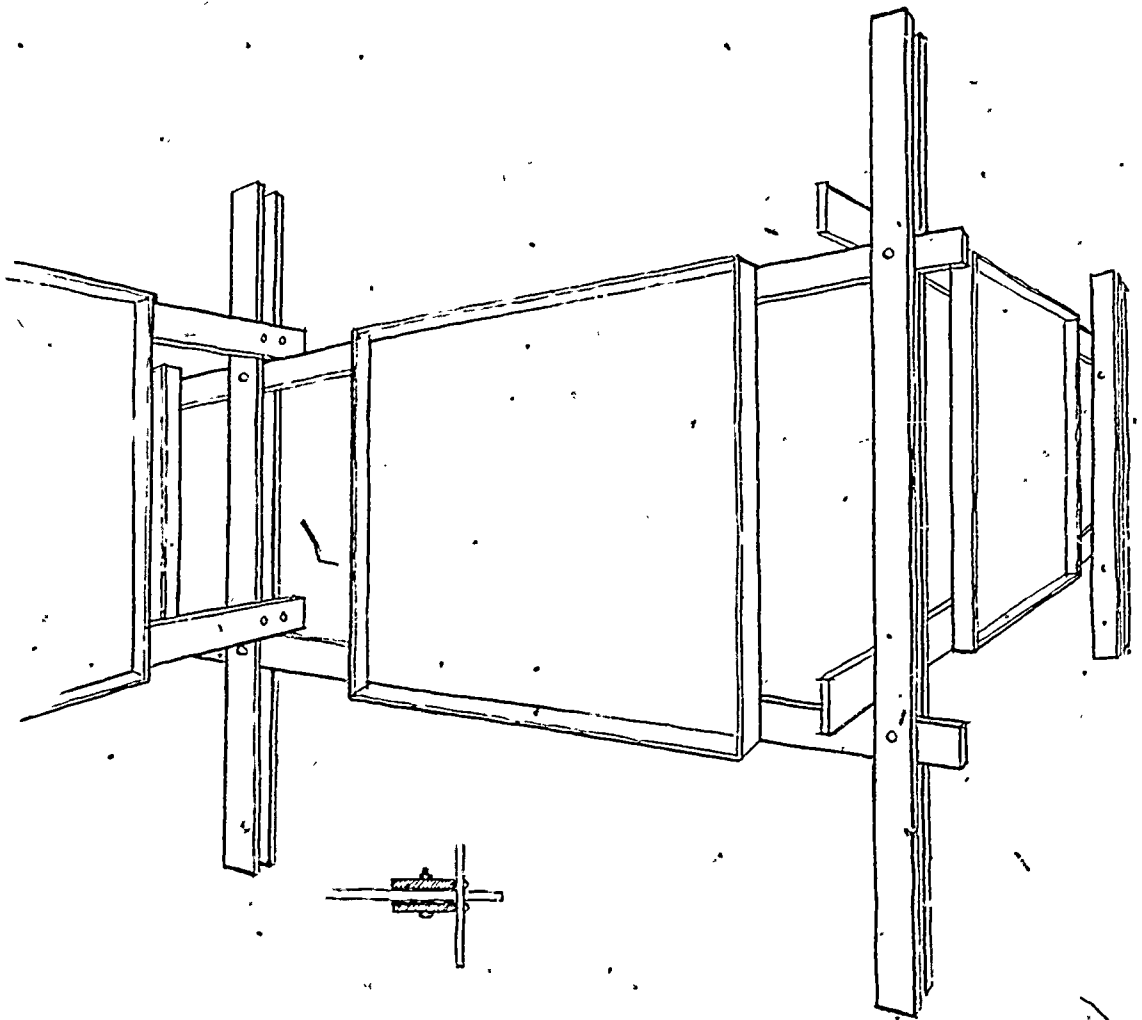

Fig. 3. Wooden exhibit 'system' using standard wooden units bolted together.

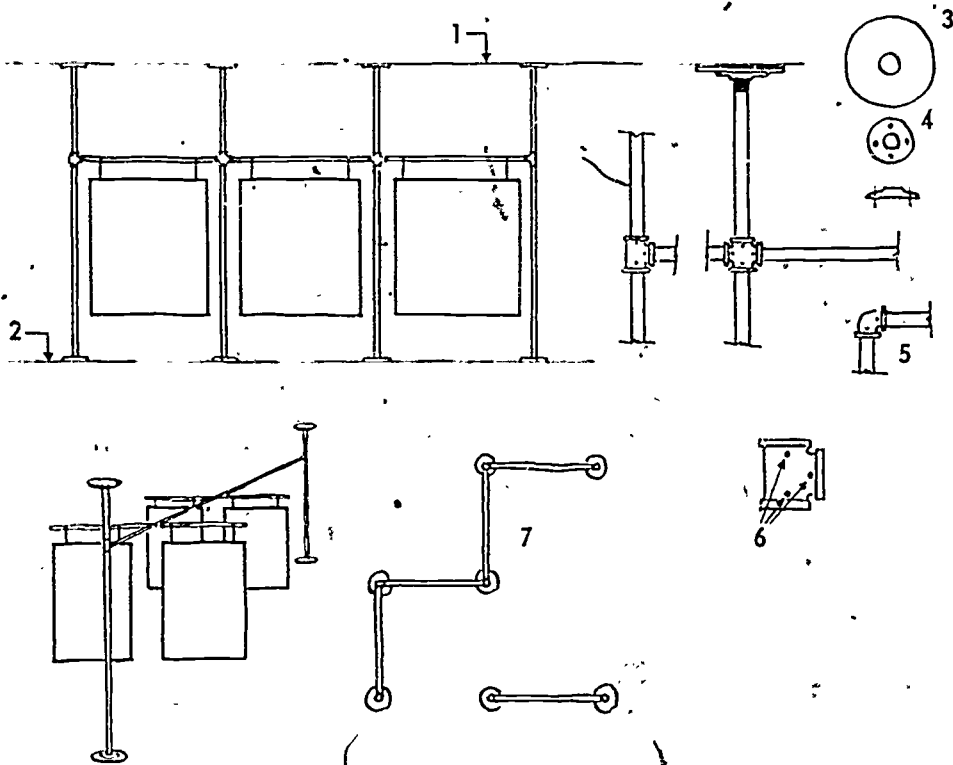

Fig. 4. Ordinary plumbers' pipe 'system'. vertical pipes are threaded at both ends so that flange plates can be extended firmly against floor and ceilings. Panels can be suspended on wires, rods or straps. Any kind of arrangement can be made, depending upon the need of the exhibit and its size. 1, ceiling; 2, floor; 3, ceiling and floor disc plus rubber disc of the same size; 4, flange plate for ceiling and floor, 5, regular pipe fittings with all threads drilled out. pipe slides through, set screws hold pipe in place, 6, holes for set screws: a bolt or a pin traverses the fitting and the pipe and the unit is thereby somewhat stronger; 7, floor plan.

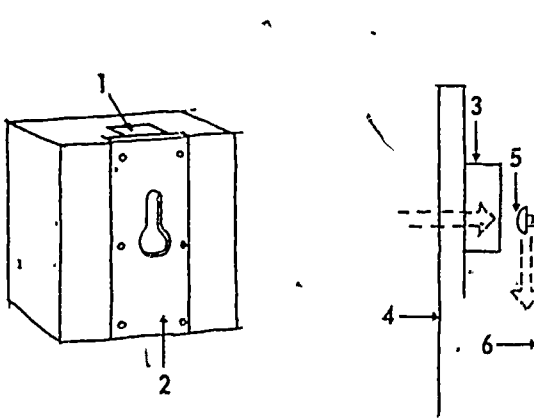

Fig. 5. Keyhole mounting system. 1, cut-out area on block to receive screw head; 2, metal plate with keyhole, nailed to block; 3, keyhole block glued to back of panel; 4, panel; 5, round head screw with head a way from wall, to receive key-hole block; 6, wall or major panel.

general guide to the exhibit in the form of an inexpensive booklet or a free mimeographed sheet (take-home label) which can be kept for future reference. Though there is strong support for this method of imparting information, it does not solve all problems. Another method of assisting the public is to provide guided lectures; this, of course, limits the museum-goer who likes to explore for himself.

Assuming that the interest of the most casual visitor has been aroused by the title and the eye-catching elements of the exhibit, a short statement should be provided in the form of a main label written in a style appropriate to all levels of the reading public. It must be simple and at the same time should so supplement the exhibit that the casual visitor learns something, even if (owing to lack of time or ability to comprehend) he does not read the more detailed labels. The main label should be cleverly written and to the point, in order to encourage the visitor to seek further information in detailed descriptive labels; but it should also be kept short so that the scholar may pass on to the more comprehensive labels. A brief bibliography of popular and scholarly publications should be given at the end of the main label for those whose interests go beyond the scope of the exhibition. The small percentage of visitors whose interests have been aroused to this extent should be able to find further information without having to inquire from the curator.

In view of the difficulties mentioned, it would be an advantage to have a label editor; but few museums have an exhibition programme which would require his services full time. Museums with small programmes and limited budgets might entrust this work to the librarian or the editor of their scholarly or popular publications. And even the smallest might take advantage of local writers, paying a small fee or recruiting them on a voluntary basis.

LABEL DESIGN

The label designer should have some knowledge of typography, printing and type faces. There are numerous books on the subject and many good typography and

commercial art journals. In the general design of typography and labels the main title should be considered first and given prominence for it carries the basic information. Emphasis can be obtained by the use of contrasting type faces and sizes and different coloured inks. Cut-out or cast letters give added impact to the main title and may also be used in a smaller size for sub-headings. The use of all capital letters is permissible in short statements or titles, but is not advisable for labels of any length.

Because our eyes have become accustomed to the lower-case letters used in books and newsprint, these should be used to guard against eye strain in fairly lengthy copy which must be read with speed and accuracy. This is one of the many requisites for legibility. Others are proper design of type face, type size, length of line and spacing of lines. Visibility refers to the capacity of being seen or distinguished against a background. Legibility is not possible without high visibility, but high visibility does not guarantee high legibility.

The main label should be designed to catch the eye at the start (Plates 3 and 14). If space permits, it should have a special position and should never be placed close enough to a specimen or model to be mistaken for an individual label. The type size need not necessarily be larger than that used for the secondary labels, provided it is in a bolder face. The format for the main label should, however, be larger, and if, owing to space limitations, the main label must be placed close to other labels, a different colour should be used. Because the nature and purposes of exhibits are so varied, the design and position of the secondary descriptive labels will also vary considerably, but the essential consideration is good readability.

Three factors determine good visibility and readability: illumination, size, and contrast. For illumination, as an absolute minimum, ten foot-candles should be used (measured on the object or label shown). Size of the type face for secondary labels should not be smaller than twenty-four point and, if space permits, a larger size should be used. Contrast between the letters and the background should be as strong as possible; black letters on a white background offer the best contrast for, although

equally strong, white letters on a black background are more tiring to the eye. If it is desired to reduce contrast, the label background should be the same colour as the wall panels or exhibit case. For the best results a sample label should be tried out for readability in the exhibit area under lighting conditions similar to those planned for the finished exhibit. But no matter what background colour is used, increasing the size of the type face will result in better legibility.

PREPARATION OF LABELS

The use of three-dimensional letters for short titles and sub-titles is quite practical and the added dimension helps to give the title the required emphasis. These letters are available today in a variety of materials—cardboard, cork, plaster, metal, plastic, and wood (Plate 4). Catalogues showing the entire range of type faces and sizes can be obtained from most art dealers and suppliers. If the ready-made letters are too expensive, letters can be cut by hand in any of the above-mentioned materials, or a master set of letters can be carved out of plaster and additional castings made using a latex mould.

Hand lettering for titles and sub-titles must be done by a skilled professional. In most countries this is very expensive, but poor hand lettering reveals the amateur and always results in bad readability. With a little practice a Leroy lettering guide will give professional results.

The amateur, with some practice and a good sense of letter spacing, can also make fairly adequate titles by pasting up commercially printed letters and enlarging them by photostat to the desired size, using either the negative or the positive. These commercially printed alphabets are available in almost all type faces and are printed on clear thin sheets of plastic with pressure sensitive adhesive on the reverse side.

Letters engraved on metal plates, engraved or routed on lucite (perspex) or varicoloured laminated plastic sheets offer further possibilities.

The typewriter should not be overlooked when it is a question of making inexpensive two-dimensional labels. An enlarged photostat of a typewritten label can be mounted on a card or, with an adhesive, directly on the

wall surface. Bulletin and electric typewriters are also useful for this purpose.

If the budget permits, the best procedure for labels is to have them set in type. A typesetter or printer will supply information on the systems that are available locally.

An exhibit with many elements of design (specimens, art-work, labels) can be made less complicated, and therefore more pleasing to the eye, by the elimination of the rectangles that are inevitable with labels printed or mounted on cards. One method that comes close to achieving the desired result is to print labels on a kraft paper (brown wrapping paper) painted, by brush, roller or spray gun, the same colour as the background. The disadvantage is that the edge of the paper is still visible and one is nevertheless conscious of the rectangle, however softened. Photo-enlargements with all the label material combined on one sheet achieve the result, but impose limitations in the use of colour.

The best results are achieved through the use of the silk screen, which offers unlimited colour possibilities (Plate 5). Silk-screen labels blend in to the background wall or panel rather than obtruding as individual elements in the design. This method is more expensive because of the equipment, training and labour entailed, but the results are more than worth the extra expense, not only for labels but in the reproduction of art-work in one or many colours on opaque, translucent or transparent surface.

The small museum which cannot afford the silk-screen process can use other methods to good effect by exercising some ingenuity in the planning and designing stages and using good methods of mounting.

Labels, graphs, charts and some kinds of art-work can be mounted with photographic dry-mounting (heat and pressure-sensitive adhesive) tissue using a heat press or an ordinary household iron. Trimming is done with a paper cutter or a circular saw. In wet mounting, glues, pastes and cements are used.

Most firms that make photo-enlargements or photostats are also prepared to mount them. Work of this type should be counter-mounted on paper of similar weight to prevent buckling. The edges can either be wrapped or trimmed flush.

Finished labels, art-work and photographs mounted on panels of masonite or fibreboard can be installed by screwing, toeing in (with nails), or glueing to keep them flat on any surface. If they are to be mounted away from the wall, blocks of wood are glued to the four corners or in the centre of the back of the label panel which is then attached to a larger exhibit panel by means of a keyhole plate (Fig. 5). These can be mounted flush with the back of thick panels or on blocks cemented to the back of the panels. The device is quite simple: the plate has a hole in the shape of an upside-down keyhole; this is slipped over a roundhead screw in the wall or in the larger exhibit panel. The panel is locked in place by moving it downwards, once the screw head has passed into the hole. Keyhole plates have several advantages: large heavy panels can be hung rather than centred on a wall and, if desirable, at some distance from it; and panels for temporary exhibits can be easily removed.

For the most effective exhibit labels three points should be emphasized: if possible, a professional label writer should be engaged; readability and visibility are the most important criteria of good design; use should be made of the best preparation techniques within the limits of the budget allotted.

LIGHTING

The importance of good lighting in museum exhibitions cannot be too strongly emphasized since, to a great extent, it determines how we see, what we see and how we feel about what we see. The common practice of designing the mounting and arrangement of exhibits before considering how they are to be lighted is an unfortunate one. A more sensible order of priorities would be to reverse the normal practice: i.e., the designer would start with the exhibits themselves, consider how to light them to the best advantage of the viewers and then proceed with the planning and designing.

Under ideal exhibition conditions every aspect of display is controllable. Artificial lighting which can be focused, moved and coloured, and which is independent of the weather, is therefore the best exhibition lighting. It is in fact a kind of artificial sun-

light that can be manipulated and projected at will, bringing with it the power to control interest, mood and attention, and stimulate pleasure. Although daylight is considered to be a constant value, it is in fact changing all the time and affecting mood and atmosphere as it does so. In northern countries, for instance, people automatically relate the glow of tungsten with warm desirable sunlight, and react against the cold glare of blue-white fluorescent lighting. In hot countries the reverse is true.

Light can attract or distract attention. Since people's eyes will always focus on a brilliant object, lighting is the simplest way of emphasizing exhibits. In the same way, lack of light can be used to conceal undesirable details and dull corners and give contrast to the bright areas. There is too much to see in any exhibition, but good lighting can at least ensure that viewing is not left entirely to chance. Anything that has shape, mass or texture can be made more interesting by careful lighting.]

Like any other medium, lighting requires to be handled with care and, above all, common sense. All exhibitions must have a fixed amount of ambient lighting in addition to the directional light illuminating the displays. There may be exceptional cases when an extremely dramatic effect is desired, but again common sense should be used. For example, a dark object, even when illuminated, can never be as bright as a light one; nor is it of any use to light an exhibit if the light source is so placed that it dazzles the observer (Fig. 6).

The two main types of artificial light source are fluorescent and filament lamps. Fluorescent lamps are extremely economical and provide a general shadowless flood of light if installed at the proper distance. They are obtainable in cool and warm colours.

Directional fluorescent tubes, a new form of fluorescent lamp, can be focused to some extent. With the standard fluorescent tubes louvres are needed to reduce glare and to help direct the light. They are most appropriate for general background or ceiling illumination, but they can be used in conjunction with filament lamps to provide directional lighting from one side. If equipped with a hood or louvres they can also be used in narrow exhibit cases.

Fig. 6. Types of illumination. 1, 2, 3, 4, types of panel illumination; 5, internal case-lighting; 6, a rule to remember: to illuminate a wall the light source should *never* be closer than the proportion of 1 to 4, otherwise 'hot spots' on the wall surface will be too noticeable, and the bottom of the panel will be in relative darkness.

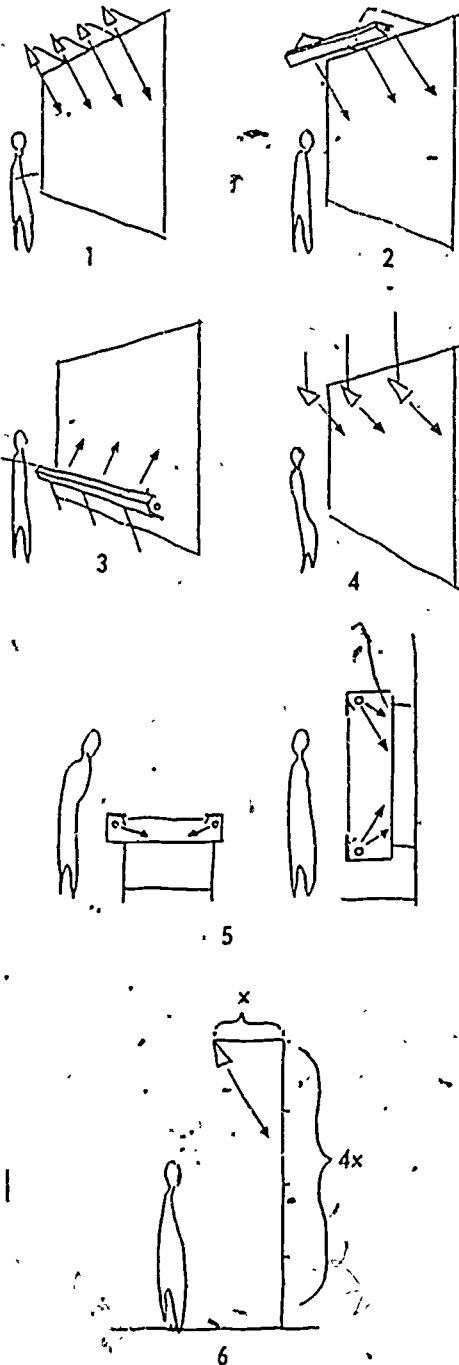

Filament lamps are less economical than fluorescent, but more adaptable for special lighting effects. For general light, frosted filament lamps arranged in lines or batteries give an effect similar to that of fluorescent lighting, but warmer and less diffused. Except when used for this purpose, they require a special fitting or reflector. Manufacturers' catalogues usually supply information on such fittings, or light hoods can be 'tailor-made' by a local tinsmith to meet almost any need.

Flood-lamps give a general light in one direction. Parallel beam reflectors cast a beam of light for a considerable distance, creating sharp shadows, like a searchlight. Focused spot lamps can also throw light a considerable distance, focusing it sharply on an object. They are quite expensive and the further the light is to carry, the higher the wattage required. Two 30-watt lamps give out as much light as a 60-watt, but the 60-watt lamp will project it further. Since filament lamps produce heat, ventilation is an important factor, particularly where the fittings are to be built into the display casing.

Wherever possible fittings for directional lighting should be concealed, especially if the exhibit is to be permanent. For temporary exhibits a flexible lighting system is most desirable, and the concealment of fixtures is not always practical. Because of the difficulty of concealment there is a tendency to use the fixtures as decorative elements; this is usually a mistake. On the other hand, the stock fittings that best suit the lighting requirements of a particular display are often awkward to assimilate as coherent elements of a design, and more elegant fittings used for effect rarely provide the best lighting for display. Like all general rules this one can occasionally be disregarded where there is taste, money, and time for experimentation (Plates 8 to 10).

Although much has been said about daylight versus artificial lighting in museums the question merits further discussion. In my view, daylight is rarely satisfactory as exhibition lighting: it varies too greatly in cold climates and is too brilliant in tropical climates; in all climates it changes direction and quality throughout the day. From a display point of view a building with no win-

dows is preferable, so that all illumination can be controlled.

However, although modern designers of museum buildings, particularly in America, are beginning to reject the architectural concept of a skeleton structure with a curtain wall of glass, most museum exhibition designers are obliged to compromise by providing for a certain amount of daylight.

Daylight can, it is true, be successful for the illumination of certain exhibits, but only in large areas where the fall of light can simulate natural exterior conditions. Natural light from side windows does not do justice to labels and display arrangements, but it can be fairly successfully used for a few selected exhibits or large pieces of sculpture (Plate 11). Natural light falling from a skylight into a cramped area may create entirely the wrong atmosphere, and even in a large area the positioning of exhibits for adequate natural lighting is difficult. In practice, therefore, if natural light cannot be eliminated it is best to use it as general light, and to supplement it by artificial light focused on the exhibits. The artificial light sources must be concealed, of course, so that the eye is not shocked by the contrast with the daylight to which it is attuned. Where the daylight enters from one side only, it may be worth while to black out the windows and rely solely on artificial light so as to avoid awkward shadows (Plates 13a, b and c and 15).

Many museologists may consider this an entirely one-sided and unacceptable assessment of the situation, presumably because we have so many sentimental notions about the efficiency and benefits of natural light. But if one considers the matter objectively and without prejudice, natural light is seen to be quite unreliable and often inefficient. On the other hand, the recognized domain of artificial lighting is expanding, for example in commercial exhibits and trade fairs where much more imagination and creativity have been shown in the display of goods; commercial exhibitions have played a more important role than museums in the evolution of present trends of exhibition technique. The problem lies not so much in creating the right atmosphere in a limited area by means of artificial light, but in making the transition from artificial light to

daylight. Once the change has been accepted, there is rarely any discomfort or even any awareness of 'unnatural' light.

ANIMATION

Movement of one kind or another is an old and reliable method of creating interest. The electric motor and flashing lights in sequence have provided exhibition organizers with an infallible technique for attracting attention to displays. The right mechanic can animate almost anything, but he must be ingenious and enthusiastic, and the maintenance must be very good. Simple, foolproof pendulum and turn-table mechanisms available on the market are recommended, for they avoid the inevitable difficulties connected with specialized machinery (Plate 20*b*). If a mechanic is available, animation is well worth the trouble involved, nothing else can so effectively focus attention on an exhibit which otherwise would be passed by as dull.

Lighting can also be used to animate models. For flow patterns and animated diagrams specially shaped vacuum discharge tubes or circuits of very small bulbs are useful. There is a danger, however, particularly with complicated technical diagrams, that people will be more interested in the animation system itself than in what it is designed to explain. Routed lucite and perspex (with edge lighting) have also been successfully used in presenting diagrams and schematic views of complicated devices. Certain other principles such as the rotation of polarized light, which can produce a whole series of interesting and seemingly complex effects by a simple rotating mechanism, have not yet been exploited and might well prove valuable.

FILMS AND SLIDES

Although temporary screens with either front or back projection are widely used in many commercial exhibitions and in a few museums, it is the back projection screen (where the projector faces the audience and a picture is projected on the back of the screen) that has really introduced the use of films in exhibitions. Compact projectors which take up little space are now available

for use with a continuous loop of film that will run automatically for long periods. Revolving disc or drum rear-projection slide projectors have also been developed for special subject matter.

Unfortunately, films and slides in exhibitions are not usually very effective. Too often they are shown under conditions of too intense light which reduce the clarity of the image. Furthermore, the public is accustomed to the technical excellence of the large movie screen and the same quality cannot be produced on a small scale. However, if the technical faults can be reduced by lighting control and good maintenance, films and slides offer enormous possibilities for exhibitions, particularly in explaining complicated or long sequences. It goes without saying that films and slides in permanent exhibits entail a tremendous maintenance problem, and unless the museum is willing to employ a full-time animation and film maintenance man, the idea should be dropped. These media of communication are only practical for temporary exhibits. A film is not a cunning technique for cramming in the scientific or scholarly data that would otherwise have to go on the exhibit labels or in a brochure. From an exhibition point of view a film or moving slides are much more important as a way of attracting attention and introducing movement, and of enlivening information that would otherwise be presented in static photographs. This means that the ideal exhibition film should be very short and trimmed down to brief, essential shots just as an exhibition story outline is pared down to brief, essential words. Unless special arrangements are made for a regular cinema audience who will stay and watch the performance through, for example for the showing of a film in conjunction with the temporary exhibit, films used in exhibitions should be short and repeated every few minutes. If the film is long, crowds will collect, block the passageways and distract attention from the other exhibits.

SOUND

Sound has been used in many exhibits, but it has been found to be a distraction rather

than an attraction, especially if a good deal of spoken text is included. The earphone type of speaker is much more effective but it is usually too expensive for temporary exhibits and should be reserved for the large permanent exhibitions. General maintenance of sound equipment is much cheaper than maintenance of animated models.

Special effects of every kind should be used with very great care and discretion. The

constant danger is that they will be so interesting in their own right that the public will not bother to look at the other displays; alternatively they may be out of key with the character of the display. It is unfortunately true that ingenuity and clever ideas can be as destructive of a good exhibition as thoughtlessness and lack of imagination. The ~~only answer~~ is vigilance and common sense in planning and designing the exhibit.

BIBLIOGRAPHY

- Art Directory*. New York, published for the Art Directors' Club of New York, Hastings House, 1957.
- BAYER, Herbert. 'A contribution to book typography', *Print*, 1959, vol. 13, no. 2, p. 58-61.
- GARDINER, Henry. 'Scale models in exhibition concepts', *Curator*, New York, 1958, vol. 1, no. 1, p. 66-73.
- GARDINER, James; HELLER, Caroline. *Exhibition and display*, New York, F. W. Dodge Corporation, 1960.
- GUTMANN, Robert, KOCH, Alexander. *Ausstellungsstände*, Stuttgart, Verlagsanstalt Alexander Koch GmbH, 1954.
- LOHSE, Richard. *Neue Ausstellungsgestaltung*, Erlen-Zurich, Verlag für Architektur, 1953.
- LUCKHURST, Kenneth W. *The story of exhibitions*, London, Studio Publications, 1951.
- LUCKIESH, M.; EASTMANN, A. A. 'Footcandles for critical seeing'. *Illuminating Engineering*, New York, 1946, vol. 41, p. 826-46.
- MOHOLY-NAGY, L. *Vision in motion*, Chicago, Paul Theobald, 1947.
- MOSS, F. K. *Reading as a visual task*, New York, D. van Nostrand Co. Inc., 1942.
- NELSON, George (ed.) *Display*, Whitney Publications, 1953. (Interiors Library, no. 3.)
- NORTH, F. J. 'Museum labels', in: *Handbook for museum curator*, Part B, 'Museum Technique', section 3, p. 10, London, British Museums Association, 1957.
- PATERSON, D. G.; TINKER, M. A. *How to make type readable*, New York, Harper Bros., 1940.
- WILLIAMS, Luther A. 'Labels. writing, design, and preparation', New York, 1960, *Curator*, vol. 3, no. 1, p. 26-42.
- WITTEBORG, Lothar, P. 'Design standards in museum exhibits', *Curator*, New York, 1958, vol. 1, no. 1, p. 29-41.
- 'Curator . . . looks at "Expo 58"', *Curator*, New York, 1958, vol. 1, no. 4, p. 41-48.
- 'The living museum', *Cultural Forum*, India, New Delhi, 1958, vol. 1, no. 2, p. 48-52.

TEMPORARY EXHIBITIONS IN ART MUSEUMS

by H. L. C. JAFFÉ

INTRODUCTION

The importance attached to temporary exhibitions in the programmes of museums today is evidenced by the discussions on this subject which take place at almost every meeting of ICOM and of many national museum organizations, some of which are also ICOM National Committees. The present practice of showing only selected items of a collection on permanent exhibition has meant that many items are placed in storage, but there is no reason to assume that these are second- or third-rate objects and therefore unsuitable for exhibition. A storeroom frequently contains a large number of variants and duplicates of objects already on permanent exhibition and the occasion may arise when it would be interesting to exhibit them with what may be described as their 'family'. Moreover, these duplicates and variants acquired in the process of accumulating a collection would be welcomed as loans for exhibitions in many other museums. This change in museum practice has been a factor in increasing museum activities, as has the fact that a growing proportion of the public is becoming accustomed to visual education and to being influenced through visual experience.

PRINCIPLES AND METHODS

The general principles for the organization of exhibitions, from large-scale travelling national exhibitions to more modest exhibitions of local antiquities in the town hall, are basically similar. They are valid for large international exhibitions of art or small ones

of historical or archaeological interest or those devoted to surviving crafts. The first principle is that exhibitions have their own idiom, a visual language with its own syntax and grammar. They differ quite fundamentally from books, both have their task to perform in promoting education throughout the world but it would be a serious mistake (and one always made in the first years of experience with a new means of communication) to try to adapt the principles of the older to the newer means. Unlike books, which are the product of logical or associative thought processes, exhibitions are based on the observation of an object or objects.

Observation is the starting point, and experience, i.e., the simultaneous emotional and intellectual perception of the objects concerned, the aim. An exhibition organizer can provide this experience either by allowing the object itself to catch the visitor's attention and then shedding further light on it by means of other related objects, or by bringing out the mutual relationship between a number of objects which have one or more features in common.

Whichever method is chosen in assembling and arranging an exhibition—and the choice is likely to depend mainly on the subject matter—the emotional or educational effect on the visitor must be the first consideration. Thus, the organizer's first duty is to present his chosen material to the best advantage by facilitating observation to the greatest possible degree. The exhibition must be honest and trustworthy (hence its importance as a means of popular education), and its reliability must begin with the way in which the object is exposed to the public. The object

must speak for itself and any supplementary effect used must serve that purpose. Respect for the object on show, for its form, colour, origin and significance is the primary requirement.

First, however, there must be a guiding principle or unifying idea so that the various objects, whether paintings, historical documents or archaeological finds, fall into place as parts of a significant whole. This unifying idea is usually reached by limiting the exhibition to a clearly defined theme. It may sometimes appear to be an arbitrary principle, for example, in exhibitions of private collections where the personal taste of the collector is the only unifying element, but it is nevertheless essential.

THE VISITOR

Every exhibition must be assembled, arranged and explained primarily for the benefit of the visitor. This, for all the brevity with which it is stated here, is a particularly difficult task. Many museum directors may have only vague knowledge of their visitors' interests and capacity of appreciation. Visitors no longer belong, as in the past, to a clearly defined social group whose interests and inclinations were familiar, in broad outline at least, to the museum curator. Today, the art gallery or historical museum may expect visitors from all walks of life. The local workers, as the source of the town's vitality, should be given particular attention. Special thought should be given to school-children, the aged, the people from the surrounding countryside, and where appropriate, to foreign tourists.

Curators should attempt to attract all these groups and should aim at a standard of exhibition which will provide an experience that will enrich their lives and broaden their outlook.

Given the varied interests of his public, the museum curator or the organizer must select as the theme of his exhibition either a subject which will have special appeal for a specific group (in which case it will be specially designed for that group) or one related to a general human problem that can be expected to arouse the interest of all groups. The problem is simpler in small

communities where the museum director lives in close touch with the population and exhibitions can cater for known interests.

This appeal to the visitor and to his receptivity to experience is the easier because there is no need to assume that he already possesses a certain body of knowledge. On the contrary, he should acquire knowledge through the exhibition, not in the same way as he would at school or from a textbook, in other words not by going through a thought process already worked out for him by others; but through direct contact with the objects themselves (works of art, items of historical interest or antiquities).

EMPHASIS ON ORIGINAL OBJECTS

The psychological impact it makes is the source of the exhibition's power of conviction. For this reason, every exhibition should be centred on at least one object, whether it be a painting, statue, historical document or archaeological find that, by virtue of its quality (which may be aesthetic, historical or even religious) appeals to and stimulates the spectator's powers of imagination. If necessary, the rest of the exhibition may consist of reproductions and explanatory material such as maps, tables and statistics, but the central object must be an original. This object is the heart and soul of the exhibition and it is precisely in this respect that an exhibition differs from a book, however well illustrated. It brings the visitor face to face with the original and results in a personal experience which cannot be gained from reproductions, representations or copies, however faithful they may be.

Emphasis on the use of originals is particularly important in art galleries and historical museums, which should give insight into the uniqueness of each work of art and each historical fact. This is the fundamental difference between art and history exhibitions and those dealing with the sciences. A chemical experiment, discovered and successfully performed by one of the great chemists of the past, can be repeated in a way which does not differ in any respect from the original, but the most skilful art reproduction can never replace the original.

However, the organizer can successfully

use many reproductions when few originals are obtainable to illustrate his theme. For example, in a small exhibition of French mediaeval stained glass which consisted mainly of reproductions, the presence of one small but uncommonly representative and beautiful original had the effect of subordinating the whole series of reproductions to the emotional experience it provided. The reproductions then served as a background and commentary intensifying and deepening the experience provided by the single original. In this case, therefore, by a brilliant stroke of psychology, the original and its uniqueness were selected as the starting point, and that uniqueness was linked with related works of art which could not be put on exhibition. This small exhibition did outstandingly well just what an exhibition should do. It provided the visitor with what he is entitled to expect: the combination of delight and amazement which results from contact with a great work of art in a well-chosen setting, which transforms the impression made by the work of art into a significant idea, and a body of facts and data that do not leave the experience of the work of art isolated and lost in the welter of data available to man today, but make it a significant part of his private cosmos. The impression made by the work of art is imprinted in his mind while, around that impression, his imagination and memory will weave other data, so that the theme of the exhibition will live on, not as an abstract idea but as a part of his personal experience.

No one can object to reproductions when they are skilfully and aesthetically incorporated in an exhibition. This means primarily that, in the interests of clarity and comprehension, an immediately perceptible distinction, even in the matter of presentation, must be drawn between the originals and the reproductions exhibited. The visitor must not for a moment be in doubt whether a work of art is an original or a reproduction or copy. For this purpose, striking and successful use has been made of photography, for example at the Holbein exhibition in the Basle Art Gallery, where the original Holbeins were interspersed with a few black-and-white photographs. These were hung unframed and, because of their different colour and presentation, the visitor was im-

mediately aware that they were not originals. At the same time they helped to enrich his mental image of Holbein's work.

Enrichment of the visitor's mental image must be the principal aim of every exhibition, and the best way to achieve it is to increase the satisfaction he can derive from looking at the works displayed.

AVOIDANCE OF DISTRACTIONS

One must take care that no accidental circumstances interfere with the visitor's pleasure. Poor ventilation, noise or bad lighting may spoil a visit, and the exhibition may be so arranged that the fullest satisfaction cannot be derived. In this respect, the most common shortcoming is overloading of exhibitions.

Many museum directors have become so accustomed in their daily work to seeing and taking in a large number of paintings and works of art of all kinds, that they forget that the average visitor, after viewing an exhibition for about an hour, begins to show signs of fatigue and even boredom.

Again, then, in putting an exhibition together the psychology of the visitor must be the decisive factor—and we discover another difference between an exhibition and a book, that boredom is synonymous with saturation. The capacity of the average visitor to register visual impressions of more or less the same type (of paintings, sculptures, etc.) is limited, and after a time he will no longer be in a fit condition to transform that impression into an inner experience. His capacity for emotional contact will be exhausted.

The maximum number of works of art of real worth that can be contemplated during one visit with pleasure, and therefore with profit, is seventy-five to a hundred. Since there are very few exhibitions which so fire the imagination that repeated visits will be made to gain a deeper impression, the organizer must work on the assumption that the exhibition will have to make the desired impact in a single visit.

CATALOGUES AND BROCHURES

One of the most important exhibition aids is the catalogue. In recent years there has been a general trend away from the conception of the catalogue as a kind of guide to the exhibition, and towards allowing the visitor to use his own initiative rather than go from room to room according to the indications in the guide. The visitor who hastily glances at his catalogue before daring to look at a picture is fortunately becoming more and more rare. The catalogue is being increasingly used, in fact, as an aid to the memory. In the past, apart from providing a guide to the exhibition, catalogues were principally a compilation of scientific data concerning the various exhibits, of value mainly to the expert—the museum curator and his professional colleagues. Catalogues are now designed for the average member of the public for whom the exhibition is intended. Scientific information which may mean little to him is thus relegated to the background and, in place of many columns of text, plentiful reproductions help, even years later, to recall impressions of the exhibition. The inclusion of reproductions in colour, when possible, undoubtedly renders catalogues more effective. Even though the colours are only approximate they do help to bring back the original impression. Catalogue introductions should describe the main features of the exhibition briefly, in clear and simple terms, rather than contain learned articles on the theme of the exhibition. Background information on the objectives of the exhibition, how the objects were chosen, the difficulties encountered, and so on, can also make the exhibition more meaningful. An introduction of this kind, which will usually be read after the visitor has seen the exhibition, will help him sort out his impressions and, later on, will refresh his memory.

GUIDES AND TALKS

There are other ways in which the purpose of an exhibition can be brought home more clearly to the visitor, the principal one being by the spoken word. There is no doubt that the opening ceremony will arouse interest

among a wider public if it is not treated merely as a formal social gathering but as an occasion also for an introductory talk on the exhibition. This duty usually falls to the organizer, but it may sometimes be more desirable to invite a leading expert, perhaps a foreigner, to give it. If the museum hall is not big enough to receive a large audience, the talk can be broadcast for the benefit of the local population. A sound, informative lecture of this type is also useful for the press and many visitors may be attracted to the exhibition through the resultant publicity.

Conducted visits are another means of strengthening contact with the public. Younger members of the museum staff should be given first consideration for this work. However, this type of conducted tour has some disadvantages as other visitors may be irritated by a group of people trooping through the galleries in the wake of a guide talking in a loud voice. Certain museums have partially solved this problem by supplying either portable tape-recorders or small transistor radios, so that visitors can follow a recorded description of the exhibition without disturbing others.

An exhibition is primarily a visual experience and the spoken or written word must remain secondary. It is therefore always advisable to set up a stand for the sale of postcards, photographs, reproductions, etc., and also exhibition posters without text which can be kept as visual reminders. The exhibition will then not make a solitary impression but will be a lasting memory, of permanent satisfaction and enduring spiritual value.

ASSEMBLING AN EXHIBITION

In general, an exhibition stands or falls by its chosen theme. It is therefore of the highest importance to consider the choice of subject well in advance and the possibilities it offers for exposition. Here we may safely leave out of account large-scale international exhibitions organized by governments. These are planned by committees of experts who usually have generous funds at their disposal for carrying out plans in a spectacular and brilliant fashion.

Themes for small or medium-sized museums

For a small or medium-sized museum the choice of a theme is a very important decision. Colleagues from other museums have often approached me with ambitious plans which were not only *a priori* impossible to execute, but were conceived on far too grandiose a scale for the setting in which the exhibition was to be held. Why should the small town where a great painter was born some centuries ago nourish the ambition of celebrating his centenary with a large exhibition of his works, most of which have to be brought from abroad, when an outstanding selection is on permanent display in the museum of the capital city? An exhibition of this kind creates only a local sensation, and the difficulties and the cost involved will never be in proportion to the intellectual and aesthetic benefits to the community. The same holds true when the municipal authorities of a small town, once the theatre of some great historical event, feel bound to collect all the documents and literature connected with that event. In itself, the organization of exhibitions dealing with a historical event or celebrating the birth of an artist is perfectly justified. But one must keep a sense of proportion and not go beyond the bounds of common sense out of local ambition and pride. An exhibition may be highly successful although it contains only a single original or very few, provided their significance is brought out by a supporting collection of well-chosen reproductions.

It is quite right, then, to start with the idea of offering the local community exhibitions on themes connected with its history and which will therefore find a sympathetic echo amongst the population. The probable reaction is likely to be very easy to gauge, particularly in smaller communities, and if the organizer is convinced in advance of the desirability and appeal of his exhibition he should not allow himself to be deterred by pessimistic forecasts. The exhibition itself will almost surely evoke a positive response.

In most historical museums and art galleries it is good practice to link exhibitions with local events and tradition. The choice of subjects should not be confined merely to such occasions as birthdays of distinguished

sons of the community, but should include, for example, a celebration of the centenary of the introduction of local street lighting, showing the completely new view of the town at night this gave to its painters; or the jubilee of a particular craft which traces its centuries-old tradition to the present.

Local arts and crafts

Exhibitions dealing with crafts such as weaving, shoemaking, bookbinding, pottery (the list could be much longer) have one particular advantage: they not only draw the attention of visitors to objects of daily use but help to maintain high standards of workmanship. Moreover (especially when accompanied by practical demonstrations of the craftsmen), they help to increase respect for the crafts which, even in the present machine age, still retain their worth and their *raison d'être*. This type of exhibition is fairly easy to arrange because examples of traditional craftwork are still to be found in almost every community, usually in the homes of private collectors. Even the organizer of the exhibition may be amazed, on seeing them together for the first time, to realize how well they complement each other and what a strong impression they make. It is usually not difficult to borrow similar items from neighbouring centres also, so as to bring out the often remarkable contrast between local styles, thereby adding to the interest of the exhibition.

Local history

It is rather more difficult to bring to life a particular historical event such as the grant of a municipal charter, the siege of a town, or the conclusion of a truce or peace. A thorough historical study should first be made to discover what problems are involved and to decide which aspects of past events will strike modern visitors most strongly. Logically the key exhibits will be those likely to have greatest emotional significance for the public. Various other points also merit full attention. In an exhibition commemorating the grant of a borough charter, for example, the following questions should

be answered. What is a borough charter? What events led up to its being granted to the town concerned? What did the town look like at the time? What effect did the charter have on the prosperity of the community? In this case, objects such as the charter itself, the town seal and a contemporary sketch of the town should be the key exhibits around which the rest of the material should be grouped, e.g., photographic enlargements, transcriptions and translations, facsimiles of any documents that are not available—all of which should help to make the purport of the exhibition clearer. In any event, the focal point of the exhibition ought to consist of a few original historical objects which, by the mere fact of their authenticity, should stimulate the visitor's imagination and powers of visualization. The physical presence of such pieces gives the exhibition its character as a visual experience, and thus differentiates it from the book on the subject which may be published on the same occasion. Apart from the few archivists who want it for their collections, most people will soon have forgotten the book, but the exhibition will have left its mark in the memory of each visitor and contributed to the development of his imagination and his community consciousness.

The commemoration of a truce or peace should be handled in much the same way. The documents and signatures should form the nucleus of an exhibition answering the following questions. Which war did the truce bring to an end? How were the countries involved affected? Why was the truce concluded at this particular place? What did the town look like at the time? What were the consequences for the town itself? An exhibition of this type (the exhibition commemorating the Peace of Münster, held in Delft and Münster in 1948, might serve as an example) also affords the opportunity to add yet another facet to the exhibition, the human touch which is imparted the moment one is confronted with portraits vividly illustrating the personalities involved, their costumes and their times.

Biographical exhibitions

A similar human relationship can be evoked through the exhibition of portraits in bio-

graphical exhibitions based, for example, on the life of a distinguished historical personality of the town. Such exhibitions enable people to visualize the man and his times more clearly than any written biography. Books can unfold the life story of a writer, a statesman or a scientist chronologically and gradually, punctuating it with references to important events, but a visual exhibition does not possess the narrative and historical means to suggest this gradual development. Its story is told not in chronological sequence but through parallel presentation of events, comparing and sometimes directly contrasting them.

For example, an exhibition devoted to a poet's life and work would provide an opportunity of comparing portraits taken at various times in his life with manuscripts of works written at the same periods. A few pieces of furniture, some contemporary drawings, paintings or photographs of the town in which he lived, or a single suit of clothes can often evoke the atmosphere in which his life was spent and his work created better than any literary portrait or many pages of description. No doubt, a poet's work cannot be fully appreciated at an exhibition, for it must be read, but an exhibition can trace. The growth of a short poem, often from the first rough draft down to the last corrected proof and its first appearance cannot give the visitor a full knowledge of the poet's work, but seeing the original manuscripts, gaining an insight into the development of the poems (the feeling that he has been able to watch the poet at work) will enable him to form an idea of the poet's work and personality. Exhibitions of this kind are thus fully worth the trouble, but one should guard against trying to make them too complete.

An exhibition cannot show everything at once, but it must be made a real experience for the visitor through one outstanding object which will bring its theme into focus. The choice of that particular object is the most difficult task which faces the organizer—another essential difference between the exhibition and the book. Books tend to be complete and to encompass all the available material. The task of an exhibition is to strike the characteristic note by means of a limited selection. The principle *pars pro toto*

applies to a very great degree to the assembling of any exhibition.

Selection of material

Remarkably enough, the question of representative selection causes the greatest difficulties in art exhibitions, in choosing, for example, from the work of a single artist, of a local school, or of a group in a particular locality. At first sight, it might be assumed that there is nothing easier than to assemble an exhibition of this type. The materials, i.e., the paintings, sculptures, pictures or pottery, are ready for show. All that has to be done is to assemble them, with due care, from the different collections in which they are to be found.

However, exhibitions that have come about in this way (and which therefore resemble the mixed bag of a day's hunting) are usually doomed to failure from the start. Only rarely, through skilful arrangement, can a convincing whole result from the chaotic jumble of works collected, for exhibitions of this kind bring into opposition two conflicting responsibilities of the museum curator. As a specialist his aim is to collect as much material as possible for a thorough study of a particular master. On the other hand, in his capacity as exhibition organizer, he must try to conjure in the visitor the clearest possible picture of the artist, using the minimum of material. The conflict between these two goals is usually resolved in favour of the former and, therefore, often to the detriment of the exhibition. Only where an exhibition organizer succeeds in subordinating his professional interest in a master or trend to his educational task, will his exhibition have a chance of success, that is to say, of leaving a lasting impression.

In the short time at his disposal, the visitor cannot be expected to sort and classify all the material exhibited and weld it into a coherent whole for himself. Therefore, the first requisite for every exhibition is a clear visual conception of the subject. Taking this as the point of departure, one can give a grasp of the underlying theme and perhaps evoke a critical attitude which may lead to new understanding. The vision of an artist's

work (which can only be arrived at through long and thorough study) must therefore be the foundation of any exhibition which seeks to offer something more than a bewildering profusion of works of art, however beautiful. It is hoped that the practice of starting such essential studies only just before the exhibition is to take place will die out. Unfortunately, this will not be possible unless the institutions responsible for the budgets of most exhibitions realize that the funds for these studies must be allotted well in advance, and that they are at least as necessary for the success of an exhibition as the money spent on insurance and transport.

The difference between exhibitions and books has been repeatedly stressed in order to bring out more clearly the essential characteristics of the former. One might also ask what the essential differences are between temporary exhibitions and more or less permanent museum collections. The permanent museum collection deals with a variety of themes and is open to the public throughout the year, whereas the temporary exhibition is confined to a single clearly defined theme and is open to the public for only a few weeks or at the most three or four months. The average visitor spends not more than an hour or two at the exhibition and only a few come a second time. The temporary exhibition, therefore, should offer a thorough treatment of the subject and at the same time should be easy to grasp. The visitor may also be given a deeper insight into fields that come to his notice only incidentally during visits to the permanent collection. Exhibits from the museum store-rooms, from other museums and from private collections will supply the additional material desired, but care should be taken to use them as a means of deepening rather than broadening the impression. It is also important to choose exhibits with sufficient individuality to make a strong impression, rather than mere parallels of material already on hand. The essential difference between temporary exhibitions and permanent collections, however, lies in the presentation and arrangement of the exhibits.

Space requirements

Anyone who has seen the same exhibition shown at two different places will appreciate the difficulty of giving advice on display techniques. The exhibition sometimes looks so different in its new setting that only someone thoroughly familiar with the material can recognize it as the same. Numerous factors such as the style of the building, the size of the gallery, the lighting will affect the display, and often the technical style developed by the staff of a particular museum gives an additional element of individuality (Plates 18a, b, c and d).

Each exhibition requires its own method of display, not as an end in itself but as a means of showing exhibits to the best advantage. Techniques, therefore, must always be subordinated to the works of art or documents on show. In the post-war years, many exhibitions have been held (and received publicity in the specialist press) in which the general reaction was more or less concentrated upon the techniques used to the neglect of the objects shown. Such exhibitions, at least in my opinion, did more harm than good to the cause of visual education because the means became an end. In spite of several successful experiments and a number of attractive interior architectural designs it has produced, this virtuoso exhibition technique is exactly the opposite of what is desirable. Of the countless ways in which to exhibit a given object or a collection, the least striking, the simplest and the least artful is always the best because it concentrates attention on the exhibits themselves.

The organizer has various means at his command, but he must also be able to deal with a number of difficulties. In the first place, he will not have unlimited space; a number of corridors or galleries which are more or less suitable for his exhibition may be available, or he may be given a large, undivided space which he can divide as he wishes by means of partitions and screens. In either event, there is the risk that his exhibition will be either too large or too small for the space available. In the first

case, he will be wise to cut out part of it resolutely so as to allow sufficient space for the rest. In the second, it is preferable to leave part of his allotted space unused, for an exhibition should display the objects according to a strict rhythm rather than spread them out merely for the sake of using the available space.

Obviously, not all rooms and galleries offer the lighting conditions and light and shade effects which the designer wants. In a large undivided space which he can partition himself he may solve the problem in several ways. And, like his colleague who has to make do with a number of set rooms, he must try to use his space to the best effect for the requirements of the traffic pattern to be followed by the visitors, and of good lighting and a harmonious relation between the size of the rooms and the contents of his exhibition. If he is fortunate enough to avoid monotony and create a sequence of spacious units integrated with the rhythm of his exhibition his arrangement will scarcely be noticed, and therefore neither mentioned nor praised by the visitors. This he may accept as the highest compliment.

Circulation of visitors

The first of the almost scientific problems an exhibition designer must solve is that of circulation, a matter in which he is largely dependent on established practices in the country concerned. The designer should be fully conversant with the habitual patterns of movement in the country, which may be influenced by whether the language is written from left to right or vice versa, and on which side of the road traffic travels, etc. The direction taken by visitors in different countries when visiting an art gallery or museum is often dictated by such customs. The planning of good circulation patterns also calls for simplicity and logic and a great deal of thought and imagination. The designer must realise that the visitor will quite justifiably be dissatisfied if his movements are too strictly controlled. The golden mean must be found between control that is too strict and such latitude that the visitor is faced with the material without being helped in any way to gain an appreciation of it. Once

the way round the exhibition has been planned so as to bring out clearly and logically the message of the exhibition it is well to provide for some short cuts. These should be unobtrusive, for example, a plan may be so placed that the visitor realizes a short cut can be made but is not strongly tempted to take it. In any event, he must feel that his tour of the exhibition—with or without short cuts—will enable him to grasp its essential message.

While the organizer should be guided by aesthetic and psychological considerations, he must also aim at avoiding congestion at the key points of the exhibition and see to it that visitors are able to examine the exhibits from the correct distance (roughly arm's length for drawings, and often from more than five yards for larger paintings). As far as possible he must also prevent visitors from hindering others while on their round through the exhibition. All these factors must be borne in mind in making the plans and this can rarely be done only on paper. A thorough knowledge of the material is necessary and the plan of the premises should be consulted constantly during the preliminary stage of organization i.e., when the exhibition is being assembled.

Accents in an exhibition

The itinerary should take into account the particular stresses the arranger desires to place in his visual narrative. It is important that the beginning and the end of the exhibition should make a special impression. In the very first room, or even in the lobby, visitors should be brought into immediate contact with the exhibition's theme (in the musical sense of the term), and the one or two leit-motifs of the exhibition should also be made clearly recognizable at the outset. At the end it is desirable to restate the theme with the greatest clarity, this time a sort of climax to the exhibition. Visitors will then feel they have grasped its meaning and will leave with the satisfaction of having recapitulated what they have observed and discovered (Plates 13a, b and c). Exhibitions which lack this closing note (which need not be accompanied by any flourish or fanfare) will leave the

visitor unsatisfied and with a feeling that the exhibition was incomplete.

The threat of monotony can be overcome by varying the arrangement in the different rooms by the use of contrast, suspense and emphasis. A great deal depends on the space available. A row of absolutely uniform galleries or a long corridor unbroken by any articulation is a threat to success. But even such premises as these can be made more attractive by lowering the ceiling in one room and varying the level of the floor in the corridor to avoid monotony.

Small alterations of the kind suggested here are usually easy to make with the assistance available on the spot and may very often work wonders.

The layout

Once the organizer has adapted the premises to suit his purpose, he will be in a position to distribute his material and to arrange the general layout of his exhibition. This he must do with due regard to the space available and the way it is proportioned, and particularly, to the placing of special emphasis. For special reasons he may sometimes show his smallest exhibits in a room other than that most appropriate to their size. On the other hand, large exhibits requiring plenty of space usually have to be accommodated in a larger gallery, although to avoid monotony exceptions may be made to this rule. For example, in a row of galleries containing only small exhibits, one at least might be reserved for a single large work which dramatically breaks the uniform rhythm of the little rooms and contributes an element of surprise. This large work should not, of course, be chosen at random and merely for the sake of variety, but should come at the right point in the development of the exhibition's theme and fit in with the exhibits in the preceding and following galleries. Otherwise, the variation in the rhythm of the exhibition will be a source of confusion to the visitor rather than an element of surprise.

The principle of variation to break monotony should also be applied in the large rooms. Nevertheless, the exhibition must have unity—too frequent changes in presen-

tation destroy the general impression and compel the visitor to switch his interest too often, with resultant fatigue and boredom. On the other hand, visitors cannot look at the same type of object for too long without becoming tired and strained. Very slight rhythmical changes can relieve such monotony. For example, if paintings of about the same size are hung at regular intervals on a wall some twenty yards in length, the visitor's eyes may be so fatigued that his attention will wander long before he has reached the end. But if the same paintings are rhythmically arranged as a group (on a chronological or any other rational basis) the effect will be less tiring.

The organizer has several difficulties to overcome in applying the principle of rhythm. In the first place, since every gallery or room is characterized for the visitor by the impression he receives on entering, he should be confronted directly with a striking exhibit which attracts his attention and sets the characteristic note for that particular room (Plates 19a and b). Once the gallery has thus been characterized, of course, the organizer's hands are somewhat tied in his subsequent arrangements. However, if he wishes full latitude in arranging a particular room to prevent the keynote of a gallery being sensed in advance, he may screen the entrance so that the visitor experiences a surprise on suddenly finding himself in a new room.

I have noticed, however (and I am not alone in this), that exhibition organizers, despite their complete freedom, often tie themselves down to an external and formalistic principle which has nothing to do with the logical and psychological arrangement of the exhibits. For example, sometimes the hanging arrangements in exhibitions of paintings are based on symmetry, with the result that two paintings which ought to have been placed next to one another, either because of their chronological relationship or their artistic affinity, are hung some dozens of yards apart. Such concessions to external and formalistic aesthetics considerably weaken the exhibition. In deciding where to hang paintings or place exhibits, the organizer should be guided only by their inherent characteristics and not by external features such as the shape or the frame. When two

exhibits 'rhyme' together by reason of their artistic affinity, the organizer is free to make use of the fact. He should not let himself be trapped into producing mere visual rhythms through fortuitous similarities in such matters as format or framing which give a false impression of relationship.

Arranging the order of objects on display

The display of the paintings of a master should be arranged in chronological order. An exhibition arranged according to this principle automatically brings out the relationship of each painting to the artist's development, for the works of an artist follow one upon the other like the links of a chain, and their order cannot be changed arbitrarily. It is the organic evolution of a master's work which gives coherence to the exhibition. However, exceptions should sometimes be made to this thoroughly sound principle so as to break the monotony with an element of surprise and give fresh stimulation to the visitors. For example, two versions of the same subject (to be found in the work of almost every painter, sometimes painted years apart) can be hung next to one another, irrespective of chronological order. This will encourage the visitor to compare the two and call to mind some of the other paintings he has already seen. There are various other means of breaking monotony, but the paintings or exhibits not included in the thematic development of an exhibition should always be made clearly recognizable as a kind of light relief. This need not be difficult: the use of a different background on the wall (or stretch of wall) on which the interloper is hung, or another method of display, e.g., on an easel instead of on the wall itself, will be sufficient to make the viewer realize that the works in question are displayed, as it were, parenthetically.

The organizer can introduce variety and differentiate between various groups of works in a number of ways. The space should not be considered only in terms of the available wall area. For example, in an exhibition of a contemporary painter whose work includes gouaches, drawings, and paintings, if the organizer wishes to do justice to all three types of work but does not wish to

mix them, he can exhibit each in a way appropriate to the technique used. The paintings can be hung on the wall, the drawings exposed on stands at an angle to the wall (so that the visitor views them from about the same angle as he would if he were holding them in his hand), while the gouaches and sketches, which are for the most part on larger sheets, may lie flat on trestle tables, the visitor examining them just as though he were leafing through them in the artist's studio (see Plate 20a). By placing accents skilfully, using his space to show off his exhibits in the best possible way, the organizer can give life to an exhibition and turn even an undistinguished series of objects into an exciting experience (Plate 20b).

TECHNICAL AND PRACTICAL PROBLEMS

A variety of practical technical aids exist such as partitions, screens, showcases (both free-standing and fitted to the wall) trestle tables, stands and the like. The larger European and American museums possess extensive stocks of technical aids of this kind and are prepared in some cases to send part of the necessary technical equipment along with any exhibition assembled by them.

Smaller museums often do not have a permanent supply, and occasionally find themselves in difficulties. However, most of these technical aids are so simple in design and construction that there should be no difficulty in finding a reasonable means of producing them with the help of local labour. The same principle applies to technical aids as to the general setting: they should be as unobtrusive as possible and not overshadow the works of art which are the *raison d'être* of the exhibition. The two most important qualities of these technical aids are maximum flexibility, i.e., suitability, for more than one purpose, and lack of any marked individuality.

Wall space

While wall space is available in every building used for exhibitions, it often presents problems when it comes to hanging pictures or other works, or it may be awkwardly

proportioned. These difficulties can both be overcome. A wall which cannot be used for hanging (either because it is made of stone or is so plastered that no nails may be hammered into it) can be adapted by fixing a wooden rail at the top against the ceiling by means of a row of Rawlplugs or screws, or else by covering the wall with a light wooden lattice and stretching jute over it (Plates 21a and b). While the former method is easy and cheap, it means that every picture has to be suspended by cord or wire. The latter, although more expensive and intricate, makes it possible to attach pictures or other exhibits to any part of the wooden lattice through the jute covering.

If the walls themselves are ill-proportioned or of proportions which are not in harmony with the works to be exhibited, the desired scale for display can be obtained by applying bands of other material. Jute, obtainable in various widths and colours, is most useful, but strong warning should be given against the use of vivid colours (at least in art exhibitions) since they usually clash with the colours of the exhibits and thus become a positive factor in an exhibition for which they are intended merely as an aid. In smaller exhibitions corrugated cardboard or grass or reed matting can serve this purpose. Indeed, the problem presents opportunities for giving free play to the imagination and for using materials (sometimes locally produced and often costing very little) which provide an excellent background for exhibits.

Panels or partitions

Where there is no wall space at all, or very little, the organizer must build walls if he intends to exhibit his material on a vertical plane. This can be done by means of partitions which can be distributed as desired over the available space, or by a system of uprights with panels set between them. All partitions of whatever type must be completely stable and adaptable to various uses, i.e., adjustable, portable, offering the possibility of fastening exhibits at any height, or of being painted in another colour without difficulty, etc. The examples described here satisfy all these requirements particularly well.

The system of uprights with vertical panels set between them lends itself well to the display of large numbers of lightweight objects, i.e., drawings, sketches, etc. In the United States, this system has been brought to a high degree of perfection at museums and trade fairs; it is known as the 'pogo-stuck' system. The uprights are held fast to the floor and ceiling by powerful springs, and panels of hardboard or a similar material are clipped to them (Fig. 4, Plates 2*a* and *b* and 22). Any museum can construct a cheaper version of this panelling by using piping of about $\frac{3}{8}$ in. diameter sawn off in the desired lengths. These can then be firmly attached to the floor by means of a rubber stop or a cork, and the stop ends attached by wires to the walls of the room. It is easier to have wooden rails running between the uprights than to clip on panels. The rails can rest on nails inserted in holes bored in the piping at the required height. Between the top and bottom rails either board or plate glass may be inserted, together with the exhibits. The principal advantage of this method is that here and there the space between the rails may be left blank to form a kind of window in which an exhibit can hang free (Plate 32).

Showcases

Lightweight shallow showcases for the display of three-dimensional objects may also be attached between the rails. Like other technical aids, showcases must be inconspicuous and adaptable to many purposes. There are two main types, each intended for a particular mode of presentation: those with only one side of glass for exhibits that can be seen fully from one side; those with all four sides of glass, for exhibits which should be seen from every angle. The first type should have a lid and shelves of various sizes for the display of objects of many different dimensions. They may be built of light wood and either stand on legs or be screwed to the wall. They may also be quite easily fixed at an angle on metal braces. Suspension rings should be fitted on some of the cases so that they can be hung vertically or horizontally (Plates 24*a* and *b*).

Most showcases constructed of glass are

easy to dismount, or to open and close, but they cannot be expected to be dustproof. The only dustproof cases are bell-glasses or cemented glass cases fitted with slotted wooden or metal frames. Recently, all-glass cases with edges permanently cemented together have been developed (see MUSEUM, 1960, Vol. XIII, No. 1). These are attractive and dustproof but, unfortunately, also expensive.

Glass showcases should always be handled with the greatest care and should not be moved unless sufficient helpers are available.

Lighting

The technical aids used for light filtration and distribution are more subtle. Generally speaking, the question whether the light needs to be subdued or intensified is a matter of geographical location. To subdue light, rice-paper or cheesecloth screens on thin wooden frames or a sheet of bunting under the skylight should suffice. Intensified lighting should not be too often used and should be reserved for special lighting effects. Spotlights of more or less standard design are obtainable everywhere nowadays and are effective and easy to use. Used skilfully—and without too much striving after effect—spotlights make an exhibition more striking and vivid and help the visitor to find the most important objects on display.

Labels

While labels should not be obtrusive, they should nonetheless be sufficiently clear to give the visitor the information he needs to guide him in his tour of the exhibition. Naturally, they cannot give full data on a subject or the entire scientific background, nor is that their function. Visitors who are particularly interested will consult the catalogue or specialized publications. The purpose of labels is rather to serve as pointers within the context of the exhibition and provide the visitor only with information which is strictly necessary. They should not be written in narrative style, but in the form of short statements similar to chapter headings or sub-titles, i.e., type of object,

date, origin, etc. The best way of preventing notices from disturbing the eye is to make them uniform. Labels may be printed on Bristol board, preferably of the same colour as the wall or background. Typewriters now exist which give almost as good results as printing and can be equipped with type of different sizes and styles. The letters should be large enough for a visitor standing in front of a painting or other exhibit to be able to read them without having to come too close or change his glasses.

Labels should be placed at a uniform height near the object they describe, thus avoiding the distraction caused by an irregular array of small cards. This has the advantage, too, that the visitor knows immediately where to look for them, e.g., to the right of the object displayed. Eye-level is the best height, for the visitor should not be obliged to bend in order to read. For larger explanatory texts serving as an introduction to the exhibition larger print may be necessary. For this purpose preformed plastic letters are practical to mount and are available in a wide variety of sizes and styles. Photographic enlargements of typed labels offer another possibility.

We cannot discuss here all the technical aids required to publicize an exhibition and attract as many people as possible, for example, posters, circulars, folders, directional arrows, etc. Every exhibition should however, receive the necessary publicity, either through technical aids or through contact with the press. The International Association of Art Critics is prepared to offer assistance in such matters.

PRECAUTIONS TO KEEP IN MIND

Any guide to the organization and arrangement of exhibitions in art galleries and historical museums ought to contain a chapter drawing attention to the danger of omissions and errors. Possibly the reader may profit more from advance warnings than from following positive instructions.

Knowledge, however, is gained by personal experience—and this often means through one's own mistakes. For the most part the mistakes made in exhibitions can be traced to a wrong attitude, that is, to lack of

respect either for the work of art or for the visitor. However unaware the organizer of an exhibition is of committing this fault, lack of respect always brings its own retribution.

Now and then at exhibitions one can see that the organizers have not shown full respect for the works they particularly wish the public to notice. This is evident, for example, from the arbitrary way in which the pictures are hung with an eye solely to effect: the paintings have been so decoratively arranged on a wall or panel that the general impression is colourful and attractive, but one hardly sees anything of the individual works of art themselves. Every work of art displayed is entitled to receive individual attention from the visitor; therefore if it is not considered good enough it should not be hung.

Another mark of lack of consideration for visitors is the organization of 'monster exhibitions' in which the individual works are inevitably swallowed up by the surrounding mass. This type of exhibition underestimates the visitor. Neither his stamina nor his feeling for nuances are properly respected. Yet, time and again the average visitor, even at overcrowded exhibitions, shows that he knows how to find those works which are worth the trouble (and, in this connexion, the word 'trouble' is particularly apt).

Monotony at an exhibition is basically nothing more than lack of consideration for the visitor, the average man whose visual education is entrusted to the exhibition organizer. The attempt to adapt various cheap tricks used in advertising in the hope of getting the visitor to 'swallow the pill' more easily is also a form of contempt. Whether he does so or not is of no importance; but it is important that he should go home with a deeper understanding and a wider outlook than he had when he came. This does not mean that the whole object is to impart a few facts, for spiritual enrichment may consist simply in learning to look at things and to ask questions and ponder about things rather than merely accepting them at face value. The average visitor will be perfectly capable of seeing through a shallow exhibition. It also shows lack of respect to treat him as though he had nothing else to do but visit exhibitions and

is prepared to wander through the galleries for hours on end without sitting down, has no need for a cup of coffee or a cigarette for the duration of his visit, and does not shrink from walking through stuffy rooms over hard floors for long hours. The warning against overlooking the physical well-being of the visitor cannot be too strong.

One of the commonest errors is to display the exhibits at the wrong height. The correct eye-level may vary from one country to the next (and even from one district to the next) but this the organizer must know, for he cannot expect the visitor to stand on tiptoe constantly or go round the entire exhibition bending down.

CONCLUSION

The effect of exhibitions is totally different from that of a book or lecture. Moreover, the purpose of an exhibition is not so much to enrich the visitor's knowledge as to enrich his spiritual experience by showing him the originals, some of the master works of the human spirit.

Whatever field of the humanities it deals with, an exhibition is not intended to increase factual knowledge but to enrich human culture, to develop what the writers of early nineteenth-century Germany liked to call *Bildung*. It is this purpose that lends such great importance to exhibitions in our day, and places such a burden of responsibility

on those entrusted with their organization. I say 'in our day', because the development and education of man (and not merely of the young and the studious) is tending to split up into a multiplicity of specialized fields. And in the process of fragmentation of knowledge, *Bildung*, the general broadening of the human mind, is tending more and more to go by the board.

The exhibition is one of the few means available to the modern educator (in the broadest and most specialized sense of the term) of drawing modern man out of his compartmentalized knowledge and confronting him with values which make demands not on his knowledge but on his gift of wonder, so that new horizons may be opened up to him which factual data alone could never offer him.

An exhibition gives the visitor an experience which will influence him longer and more profoundly than anything he has merely learned by reading. His mind can better retain the purity, sincerity and reality of something he has seen.

This, too, places an enormous responsibility on the organizer. The impression he gives the visitor will be lasting and any lack of respect for purity will emerge. If the organizer is to live up to his responsibility, he must realize that his work can never be an objective in itself but is always only a means—a means of instilling respect for art and history, and therefore for human dignity.

EXHIBITIONS IN THE TECHNICALLY UNDERDEVELOPED COUNTRIES

by Hiroshi DAIFUKU

INTRODUCTION

Temporary and travelling exhibitions have been a major factor in increasing the importance of museums as cultural and educational institutions. This is undoubtedly an improvement over the former static conditions which still prevail in some museums where exhibitions remain unchanged for decades, in open storage as it were. But although temporary and travelling exhibitions are important, museums cannot neglect their traditional responsibilities—research, the accumulation of collections, and the preservation and care of objects placed in their trust—without demoralizing the curatorial staff and weakening the institution.

If they are to play a vital role in the cultural life of peoples (and museums today are increasingly dependent upon public support) it is essential that their programmes be well rounded.

In all parts of the world the decades following the second world war have seen an unprecedented series of rapid social and cultural changes. Museums cannot fail to be affected by these changes also. The challenge is greatest in those countries which have recently acquired political independence and where educational standards have been lowest. If these countries did not have the example of museums in the technically developed countries to follow, they would probably be forced to create similar institutions as a record and a means of preserving their traditional cultures. This need is so vital that, in spite of the conflicting demands of economic development, a large number of such States are establishing national museums. In some instances existing museums

are being enlarged and in others new ones are being set up.

Most of them are faced with the urgent problem of building up representative collections of material produced by the peoples of their country before the old patterns of living, worship, etc. break down or disappear. In these countries, too, the requirements of educational programmes (in which temporary and travelling exhibitions will play the chief part) are bound to be much higher than in countries which are not undergoing such revolutionary changes. Hence temporary exhibitions dealing with a single central theme will be more necessary there than in more stable environments.

The methods developed in older museums, such as the use of more theatrical effects for temporary exhibitions, provision of more explanatory material in the form of labels or by means of diagrams without text, should prove extremely useful to museums in the technically underdeveloped countries. The public in such countries has not formed the habit of visiting museums, so that even in permanent exhibitions the techniques developed for temporary exhibitions can be used more often than is customary in Europe or North America.

THE VISITING PUBLIC

A number of analyses have been made of the background of visitors to museums in North America and Europe (Daifuku, 1960). It was found that the adult visitors were not representative of the general population, indeed, in most instances about half the visitors had college degrees. Rather naturally then, the

organizers of exhibitions, without consciously taking this factor into account, presuppose a fairly high level of knowledge among their public. Museums have not yet taken up seriously the problem of preparing exhibitions for a more heterogeneous public. The inadequacy of present programmes was shown when a major publicity campaign was launched to attract a large number of visitors to an exhibition of Japanese art. This exhibition had previously been shown in other cities, where it had been well received. But the very success of the campaign, which resulted in attracting a wide range of visitors unacquainted with art and who normally did not visit exhibitions, resulted in disappointment because there was no interpretive material designed for such groups (Bigman, 1956).

In the technically underdeveloped countries the gap between the curator's standard of education and that of the visiting public is much greater, and in many cases, for the general public, museums are merely popular places to visit. In tropical Africa, for example, a majority of museum visitors may be illiterate, possess different tribal backgrounds and speak unrelated languages. A recent study undertaken in the Uganda Museum at Kampala, revealed that the level of comprehension of most of the visitors, particularly those from the surrounding countryside, was much lower than the museum staff had expected (Vowles, 1963). The museum had used many of the exhibition techniques developed in Europe and attempted to produce exhibitions which would be of interest to the local population. The study showed, however, that much more would have to be done in order to bridge the gap in comprehension. The experience in Kampala probably holds true elsewhere, and should be borne in mind by all curators in charge of exhibitions.

It is perhaps a commonplace that visual experience can be more easily remembered than a written or verbal description. Even here, however, a word of warning is needed, for much of what we accept may depend upon the conventional forms developed in our own society and may not be understood or appreciated by someone from another culture. A visitor to a motor show in a major European city, for example, may have

a keen appreciation of the mechanical features of a car which differentiate it from others, and may admire the talent of the designer. The same visitor, on seeing a Japanese *sumi* or black ink brush painting, may be completely unappreciative of the long tradition behind the work of the artist, the relationship with calligraphy, the discipline demanded in the use of the brush, where a line once drawn cannot be modified or overpainted as is done with oils. Similarly, we have become accustomed to black-and-white photographs and are aware that they represent, in varying shades of grey, different colour tones. Someone from a tropical region may, however, completely misinterpret a black-and-white photograph of a scene from a temperate area or of rug designs which he is accustomed to seeing in colour.

Museum staffs from industrialized countries have a difficult problem of communication in preparing programmes for a public with a non-industrial background. Furthermore, even in the countries in process of development, there may be a very wide cultural gap between the urban population, which is familiar with industrial products and has been educated in leading schools, and the rural population which has not been affected by industrialization. Hence, in preparing a temporary exhibition, it is valuable to hold a preview or trial view for a sample of the public who can be questioned on their reactions. Before opening the exhibition to the public explanatory material can then be prepared for exhibits which were not understood.

PROGRAMMES FOR TEMPORARY AND TRAVELLING EXHIBITIONS

Ethnographic and historic exhibitions

These have the advantage of dealing with material which is already more or less familiar to the visitors of the region (Plate 26). Nevertheless it should be kept in mind that the average visitor may have a somewhat ambivalent attitude towards the objects on display, considering them 'primitive' relics of the past. He may also feel that ex-

hibitions showing such material will not help him either to understand the present or to acquire information which would be useful to him in adapting himself to future requirements, particularly the acquisition of new techniques based on contemporary industrial technology. On the other hand his interest in the achievements of the past and their relationship to the present may, at times, lead him to make naive claims of great originality for the local crafts. The museum can do a real service by showing both their distinctive characteristics and features they possess in common with the products of other cultural areas.

A most successful programme of this kind has been carried out by the open-air museum in Niamey (Niger), showing the types of houses and the characteristic furniture used by the different peoples of the Republic. The total number of visitors per annum exceeded the population of the city, an indication that many returned for a second visit, and in addition many came from the surrounding countryside. The exhibition is semi-permanent, many of the houses being built of earth or straw, and the exhibits also include tents of nomadic peoples.

A conscious effort is also being made, in special programmes, to show schoolchildren the different cultural traditions and ways of life which are fast disappearing. Temporary exhibitions in this field, lasting from one to four or five months, attract large numbers of visitors. The presentation of an artifact in such a way that its aesthetic and even its technical value can be appreciated, gives those who may be familiar with an object in ordinary use an opportunity to see it in a new perspective. Often, indeed, the neglect caused by over-familiarity can be overcome by the appreciation of 'foreigners'. Curators may work towards the same effect.

Exhibitions on cultural problems

The preparation of exhibitions dealing with cultural problems offers possibly the greatest challenge to museums. The behaviour of all peoples, what they desire and expect in life, are based upon cultural patterns. To a considerable degree the systems of values which motivate an indi-

vidual within a given society are held unconsciously, i.e., they are unreasoned and are absorbed as a result of various influences such as traditional beliefs, goals acquired as a child, scenes from the cinema, publications of various kinds, etc. A considerable number of these beliefs will be shared in common by a given group of people. If the curator is a member of the same group he has the advantage of sharing these assumptions, but at the same time it is difficult for him to see them in their proper perspective. On the other hand, a curator having a different cultural background may prepare exhibitions which completely miss their point because he is ignorant of the values held by the local people. In the former case the curator must, because of his opportunity for gaining specialized knowledge, attempt to set aside his own prejudices; in the latter, he must acquire understanding of the local system of values, if he is to prepare exhibitions which will enable the visitor to see things in their proper perspective.

For example, among peoples in the industrialized societies of the West, many would refuse to be seated at a table with thirteen people present or accept a room in a hotel on the thirteenth floor, etc. This, in spite of long exposure to conditions where material progress has been effected through the development of modern technology, in which numerology plays no part. Beliefs which are non-logical and not based upon known scientific principles are much more widely held in environments where the effects of scientific development are less evident. A great deal of practical work, in agriculture, for example, is based upon the pragmatic experience of generations. Nevertheless, should a crop fail, or should there be increasing desiccation of pastures owing to population increase and consequent deforestation, over-utilization of the grasslands, etc., the difficulties are frequently ascribed to witchcraft, improper observation of religious rituals, etc., rather than to their true cause.

Such analogous problems as the causes of illness and malnutrition due to improper diet (which may also be ascribed to supernatural causes) are also proper subjects for exhibitions. By bringing to visual focus the real causes of problems and ways of meeting

them, the visitor will be encouraged to work towards realistic solutions and helped to understand the relationship between cause and effect. All types of exhibition, whatever their subject, can broaden the mental horizons of the visitor, help him to overcome an ethnocentric attitude, and gain an appreciation of the cultural and scientific achievements of all mankind.

Industrial and technological exhibitions

Industrial fairs at which manufacturers from several different countries show their wares are becoming increasingly common. They have a legitimate place in view of the programmes of industrialization now being carried on throughout Africa, Asia, Latin America, and other areas. Nevertheless, the articles shown are the end products of a pyramidal system behind which lie research laboratories, mines, processing plants, perhaps the assembled products of a dozen different manufacturers, etc. In an industrialized society, the man who uses a tractor is more or less consciously aware of the complex which lies behind his machine and knows something of the historical transition from the simple hand- or animal-powered implement to the highly efficient machine of today (Plates 27a, b and c). He is also aware of the great social problems and conflicts occasioned by society's adaptation to mass production and consumption and which continue today, though in less acute form. But in many countries where an abrupt change is taking place from a Neolithic peasant economy to the use of the finished product of the latter part of the twentieth century this is by no means true. The museum exhibition can help the visitor to bridge this gap and to understand the background of contemporary industrialized societies. Too often expectations are pitched too high and the stresses experienced by industrialized countries during the nineteenth and early twentieth centuries are not understood. While there is no need for the countries now acquiring industry to repeat either the social conflicts or the scientific studies of the past, an understanding of this background could ease transition from the present to the foreseeable future.

Exhibitions on health problems

Exhibitions on health problems for a largely non-literate public which is not accustomed to using the findings of modern science require special preparation. The stresses imposed by acculturation have often led to an increase in tensions, with resultant fear of witchcraft, and an increase in psychosomatic illnesses, such as hysterical seizures, unexplained aches and pains, etc. Rational explanation through exhibitions is not the complete answer, for in industrialized societies where knowledge of science is much more widespread, psychosomatic illnesses are still common. Nevertheless, a significant percentage remains unaffected and the percentage will increase if people learn to understand the forces at work.

Museum exhibitions dealing with diseases caused by micro-organisms can give a much more straightforward message, and are used to supplement school and public health programmes (Plates 28a, b, c and d). (Biological supply houses make available material suitable for exhibition purposes which can be adapted for local use.) A compulsory vaccination programme may, for example, arrest the spread of a given disease, but unless an exhibition is prepared to explain how the vaccine functions, its effect will be accepted as 'miraculous' and the local population will gain no new knowledge or understanding.

Natural history exhibitions

Almost all species of farm animal used today were originally domesticated during the Neolithic period. With the exception of these few species which man adapted to suit his economic needs and which have thus survived, man has been responsible for the extinction rather than the survival of the different species. The record has been particularly black during the past century among the industrialized peoples and unfortunately the same error is being repeated by the peoples who are now becoming industrialized (Plates 29a, b and c).

The animals domesticated by man have shown, under his husbandry, amazing adaptability to a wide range of ecological

conditions. Nevertheless they are not always the best suited to a particular environment and, as in the African grasslands, they may be a major factor in upsetting ecological balance with ultimate loss of productivity. A bare beginning is now being made in the taming, and perhaps ultimately the domestication, of some of the herd animals of Africa which are better suited to the maintenance of pasture lands in that region. The control of game as an economic resource is also of growing importance.

These programmes have frequently encountered deep-seated prejudices. The science of ecology is itself relatively new and understanding of the intricate checks and balances found in nature is not easy to impart. Conservation programmes may, after all, meet considerable resistance even among people in the highly industrialized countries, the more so among peoples having entirely different cultural values.

To help root out such prejudices the American Museum of Natural History has prepared a series of instructive exhibits on the despoliation of land in New York State, contrasting the sylvan conditions of the sixteenth century with the agricultural exploitation of the nineteenth century and the eventual progress to modern farming methods (Plates 30*a* and *b*). Exhibitions of this type which can encompass several centuries would undoubtedly be most useful in countries faced with the problem of introducing modern agricultural methods. The work of field agents from government services who give instruction by direct demonstration or on pilot farms can also be furthered through the use of such visual aids (Plates 31*a* and *b*).

It would seem, for example, that a 'logical' explanation should be sufficient to persuade a people to co-operate in reducing stock when pasture lands are being overgrazed. However, a number of well-documented cases demonstrate that such programmes, when imposed by fiat, frequently meet strong resistance. The people concerned may believe that this is a means of impoverishing them, or, rather than valuing livestock as a source of meat, they may attach greater importance to length or shape of horns, size of herds, etc. The didactic exhibition demonstrating cause and-effect

correlations may supplement a programme designed to change the value system and bring about the adoption of a system under which greater prestige and profits result from efficient use of the land and stock.

PREPARING TEMPORARY OR TRAVELLING EXHIBITIONS

The preparation of modest temporary or travelling exhibitions need not take a great deal of time but great care must be taken that the information on which it is based is correct. Many museums devote one or two cases, sometimes in the lobby, to a small exhibition on a specific topic, perhaps showing the latest gift received, the museum's most recent acquisition or certain aspects of research in progress. These tend to focus interest and to encourage repeated visits. Similarly, small travelling exhibitions, such as those prepared in self-contained portable units such as the 'suitcase' exhibit (Plates 32*a*, *b* and *c*) require little time to set up.

More important temporary exhibitions do require a good deal of preparatory work and research, and if the collection shown is to be representative it may be necessary to arrange for loans. If material is to be obtained from institutions in other countries such problems as shipping, insurance, clearance through customs, will require long and careful negotiations and a series of precautions.

Many types of exhibition furniture such as panels, stands and cases can be used over and over again, but for important or unusually shaped objects special cases may have to be designed. In some countries, such as the United States, prefabricated units are manufactured which can be assembled and dismantled easily (Plates 2*a* and *b*, 33*a* and *b*). Quick-drying, water-soluble paints, such as the latex emulsion paints, are widely available and have proved a boon in the preparation of temporary exhibitions. A new coat can simply be rolled on panels and case interiors to suit the requirements of a new exhibition or to freshen the background.

In a number of countries (Poland, France and the United States) mobile units have been

constructed using either a modified bus or a truck or tractor-drawn trailer. Mobile museums (Plates *A, b* and *c*) or similar units, will probably be constructed in the underdeveloped countries as highways improve and the need for didactic exhibitions in rural areas becomes more evident. The mobile unit has the advantage over the ordinary travelling exhibition of being self-contained, thus eliminating the problem of adapting an exhibition to fit into rooms of a different size and presenting different lighting problems. The risk of theft, fire or vandalism is also less.

EDUCATIONAL PROGRAMMES

If a museum is called upon to produce a series of temporary exhibitions, particularly if they are to be carried out systematically in co-operation with schools or community programmes, it is advisable to employ a full-time education specialist. The specialist works in co-operation with the curator and the exhibition specialist in preparing exhibitions, and particularly in advising on the preparation of labels and other information media. He also provides the chief liaison between the museum and the other institutions and takes charge of the circulation of travelling exhibitions.

In some countries, e.g., Latin America, the curator may speak only one language (Spanish or Portuguese) and may not know any of the languages of the original inhabitants which are still used in the country districts. The problem of communication and of using guides conversant with two or more languages will have to be dealt with. In West Africa several unrelated languages may be spoken within a single country and, more frequently than not, the only common means of communication is the European language introduced by the former colonial administrators. There are a number of possible alternatives, all requiring budgets: (a) printing labels in two or more languages; (b) arranging guided tours in several languages; (c) supplying recordings in several languages.

If illiteracy is a problem, some form of guided tour is indispensable and visitors should be allowed to ask questions and be

encouraged to seek more information. For this reason the most successful programmes of this kind use specially trained guides. (In some American museums, university students who have specialized in the museum's field of study are engaged as guides or 'docents'. They thus gain experience and earn a small stipend.) Teachers in school systems which make regular use of the collections of a particular museum may also be given some special instruction by the museum staff concerning the contents of the collections and the background of the material shown (ICOM, 1956). In some countries a week of instruction in the use of museums is given in teachers' colleges.

Interested local people and museum guards sometimes make quite successful guides, particularly for folk or ethnographical material. At the Uganda Museum in Kampala, for example, the guards are skilled musicians and each day give ethno-music concerts playing the instruments shown in the museum. Similarly, local farmers may be able to give demonstrations and discuss the use of outmoded implements or show urban visitors the typical ways of doing things in the country. It is obvious, however, that for exhibitions on the fine arts, cultural values, science, etc., there are limits to the usefulness of persons who lack specialized academic training. They can be given information and helped in preparing talks covering the exhibition in sufficient detail for the average visitor, but the curator should always exercise caution in selecting such people as guides (including those who are better educated but lack the necessary specialized background). No misinformation which would weaken the exhibition must be allowed to creep in.

Recorded talks by a curator or specialist in the field offer other possibilities. The least expensive method is to record them on disc or tape to be played at fifteen-minute intervals, and if necessary in several languages consecutively. More expensive alternatives would include: (a) short-range broadcasts on three or four different channels to which the visitor can listen in the language of his choice by means of small transistor radios equipped with earphones; (b) portable tape-recorders equipped with earphones. These alternatives entail fairly

high maintenance costs and replacement of parts may be difficult.

Push-button-operated daylight 16 mm. ciné or 35 mm. slide projectors with sound are another device for giving background information on the exhibit in one or more languages. Such units may be placed in the lobby or at the entrance so that the visitor is introduced to the subject before seeing the exhibition. Here again problems of maintenance may arise but they are less difficult than the maintenance of radios and tape recorders.

Few museums are able to consider the use of such elaborate systems for they require a fair-sized technical staff and an active programme of exhibitions. Nevertheless, some of the larger museums in the countries now in the process of development will be able to use such equipment in the near future.

GENERAL DISCUSSION

An active museum programme should include, in addition to its traditional tasks of collection and study, an exhibition programme designed to encourage regular visits. This means showing the 'permanent' collection, which usually includes the most important or significant items, and arranging also a series of temporary exhibitions on different subjects or themes.

The word 'education' (Latin *educere*, 'to lead forth') means to draw forth, to train or to cultivate. Museum exhibitions, at their best, attempt to live up to this definition. And since an exhibition shows things, museums can be classified as institutions which, as part of their activities, carry on specialized programmes of visual education (perhaps also audio-visual, if talks, lectures, guided visits, etc., are taken into account). Nevertheless the museum exhibition should not be confused with other types of audio-visual aids, each one of which has a particular contribution to make. The distinguishing

feature of the museum exhibition is its emphasis on original objects, or the re-enactment of an original experience (or, in the case of technology museums, experiment) and the re-creation of the past using original historical and prehistoric material.

The preparation of any good museum exhibition demands a staff which includes specialists in its particular field. It is this emphasis on research and the need to be as exact as possible which accounts for the length of time required for the preparation of museum exhibitions. It is this quality which has won for museums a hard-earned reputation for reliability which should not be sacrificed by shallow or repetitive temporary exhibitions. Nor should museums undertake over-ambitious exhibition programmes which demand so much from the curatorial staff that their basic work of research suffers in consequence.

The curatorial staff will nevertheless be called upon to devote an increased share of their time to 'applied museography'. The need for exhibitions which can enlighten and educate and at the same time offer the visitor an enjoyable experience is becoming increasingly urgent, particularly in museums of countries undergoing rapid cultural, economic and social changes — in some cases an almost abrupt transition from mediaeval or even Neolithic conditions to those of the modern state.

On the whole exhibitions on subjects about which the public has some background knowledge are relatively simple to prepare. However, even on familiar subjects a number of misconceptions may be held which exhibitions can help to correct. For example, overgrazing and resultant erosion may be blamed on causes other than the true ones, conservation of wild life may be opposed although it would mean economic gain. Exhibitions using actual material can clearly demonstrate the beneficial effects of reducing herds and planting cover. Social problems may be similarly treated.

BIBLIOGRAPHY

- BIGMAN, S. K. 'Art exhibit audiences', *The Museologist*, Rochester, N.Y. (U.S.A.), June and September 1956, nos. 59-60.
- DAIFUKU, H. 'The museum and the visitor', in: *The organization of museums: practical advice*, Paris, Unesco, 1960.
- ; BOWERS, J. 'Museum techniques in fundamental education', in: *Educational studies and documents*, no. 17, Paris, Unesco, 1960.
- VOWLES, V. 'An African museum and its public', *Museum*, Paris, Unesco, 1963, vol. XVI, no. 3.
- ICOM Education Committee. *Museums and teachers*, Paris, International Council of Museums, 1956.

PART TWO

TRAVELLING EXHIBITIONS

FOREWORD TO THE REVISED EDITION

by Grace L. McCann MORLEY

The *Manual of Travelling Exhibitions*, published by Unesco in English and French in 1953, proved so useful that it was out of print a few years after its appearance. It is now reissued in a revised version as one section of this book. Its guidance on organizing, packing and handling travelling exhibitions is thus supplemented by advice and information on the installation of temporary exhibitions.

The original text emphasized care, safety and accepted procedures for handling exhibitions of art, with the notation that the same techniques were applicable to all museum objects of whatever character—for example, in the fields of history, anthropology, archaeology and the natural and exact sciences, when their fragility and value place them in the same category as art. Travelling art exhibitions have a longer history and pose more complex problems of packing and care than any other type of material. In the United States, the experience acquired in this field has been particularly comprehensive and valuable. This is largely due to the work done by the Museum of Modern Art in spreading knowledge of modern art, in the varied forms of fine arts, architecture and applied and industrial arts, across a very large country from the early 1930s, and the later development of circulating exhibition services (notably those of the American Federation of Arts of New York and of the Smithsonian Institution of Washington). Mrs. Osborn's text of 1953 summarized this experience and based on it recommendations for those interested in undertaking similar programmes. She drew on museum leaders

and museums in many parts of the world for examples, suggestions, information concerning specific conditions and illustrations of outstanding exhibitions as shown by the list she gives in her acknowledgements section. This revised edition modifies and completes her text by reference to developments of recent years, thus giving a degree of fulfilment to her expressed hope that the *Manual* would become a rallying point for additional information and recommendations based on the experience and suggestions of others already actively associated with circulating exhibitions or undertaking them and using the *Manual* as a guide.

Her text is brought up to date in this revision, and some additions have been made to it. The illustrations accompanying it have been reviewed; those which continue to furnish useful examples of techniques have been retained, and new examples have been added, in the form of drawings and diagrams as well as photographic views. It should be noted that the fashion of design and of presentation of material tends to change from year to year, often influenced by fashion trends developed in commercial display. Thus, while basic principles of exhibition remain constant, appearance in colour, design, detail and proportion vary. Purely technical matters of packing and handling are fundamental and, except as new products become available and prove useful, they change only as refinements and variations are introduced. This distinction between the basic principles of handling museum objects and trends of fashion in presenting such objects in exhibitions should be kept clearly in mind.

MANUAL OF TRAVELLING EXHIBITIONS

FOREWORD TO THE FIRST EDITION (1953)

by Grace L. McCann MORLEY

Travelling exhibitions have already demonstrated their usefulness in many parts of the world. They bring to remote places the possibility of knowledge and enjoyment of the arts, sciences and history provided for large centres of population by great museums and exhibiting organizations. Going from country to country, they furnish an intellectual and cultural interchange of great value and broad influence. They can be used very profitably to enrich education at all levels and in all fields, and can be adapted as needed to impart information, to give instruction and to offer pleasure.

It is not surprising therefore that Unesco's advisers for museums and exhibitions, from the early history of the Organization, urged international exchange of exhibitions as one effective way of contributing toward its general purposes. They were not unaware of the frequent international exchanges of exhibitions, especially of art, already taking place. However, they noted that this exchange operated primarily for very large, very important exhibitions, among a fairly limited number of the great cities of the world. They advocated increasing this activity so as to establish a network of international exchanges of additional exhibitions—not necessarily large, but representative and diversified—which would serve in interpreting one people to another and would go to the more remote regions of a country as well as to its great centres. Delegates to General Conferences have repeatedly agreed with their recommendations, and an international exchange of exhibitions programme has finally been launched under Unesco's direction.

The general recognition of the merit of a

project is, however, far from sufficient to assure its successful development. As soon as ways to effect international exchange of exhibitions were considered it became evident that practical technical guidance was greatly needed. Some countries had long and varied experience in organizing, preparing and packing exhibitions of different kinds for travel and for the repeated showings in different places under varying conditions that the Unesco programme sought to bring about. Many countries had very little experience or none at all. No general guide on the subject existed. In this manual Unesco provides such a guide, as the indispensable first step in helping all its Member States to participate in its exchange of exhibitions programme if they desire to do so.

The vast distances of the United States, the extremely varied conditions for exhibition there, as well as its extensive use of the travelling exhibition in all fields, prompted seeking one of its experts in the subject as author of the guide. On the advice of the American Federation of Arts—at that time the leading agency of the country for circulating exhibitions—Elodie Courter Osborn was invited to undertake the task of writing the manual. It was to be based on experience and practice in the United States, augmented by information from other sources.

The choice of Mrs. Osborn was fortunate. For many years she was head of the circulating exhibition department of New York's Museum of Modern Art, at the time of its greatest activity in circulating exhibitions. Under her direction, exhibitions of every type, size and complexity were assembled, boxed skilfully for ease and safety of frequent unpacking and repacking, circulated back

and forth across the continent for one or several years at a time, and even sent outside the country.

The museum's techniques for handling travelling exhibitions are generally recognized in the United States as outstanding in their care for the safety of the objects and in their regard for the convenience of the exhibitor. As these exhibitions included, in addition to painting, sculpture and the graphic arts, industrial and applied arts and architectural models, Mrs. Osborn met and solved in her work almost every conceivable problem of assuring safety and ease of handling for material in travelling exhibitions.

She has added to her personal knowledge and experience and to the advice of American colleagues as much information on the subject as she and the officials of Unesco's Division of Museums and Historic Monuments could gather from other sources throughout the world. This manual is, therefore, the most complete survey of all aspects of travelling exhibitions yet made, though Mrs. Osborn has emphasized that it is to be considered only a first statement which should be augmented and supplemented as others provide additional information,

comment and suggestions. It supplies, however, a thoroughly practical guide for travelling exhibitions in general, with the special attention to their international movement that Unesco's concern with the problems of crossing frontiers prompts. Though the majority of examples used are drawn from the field of the arts, the principles, as Mrs. Osborn herself states, are applicable to all objects that can be used in exhibitions. Their success for the safe and efficient handling of art objects, generally likely to be fragile and of great value, assures their usefulness for other fields where loss or damage is perhaps not as tragic but is equally to be avoided. This manual, therefore, will greatly help all those who organize exhibitions of any kind. Museum experts who already are familiar with most or all of the techniques described have reason to rejoice that the benefits of travelling exhibitions, within frontiers as well as across them, will become more accessible to their colleagues everywhere under this practical guidance. Everyone, indeed, concerned with exhibitions will be grateful to Unesco for making generally available the best information on the subject by producing this publication.

TRAVELLING EXHIBITIONS

by E. C. OSBORN; revised by Grace L. McCann MORLEY

INTRODUCTION

We tend to think of museums solely as repositories for objects, principally those of the past, and yet today many of these institutions, both large and small, share their collections with other museums, art galleries, public libraries, universities and schools. Nor do they rest on their laurels by displaying permanent collections alone, but often introduce into their galleries travelling exhibitions which bring their own activities into closer contact with their communities. Exhibitions which travel have become more and more popular, particularly since the close of the war. For some time now the arts, especially, have provided material for travelling exhibitions of great variety in all countries. Travelling exhibitions in the fields of science and history, generally of more recent origin, are less numerous, though as means of general information and education they are receiving increasing attention. Unesco, in particular, has made great use of exhibitions of informative panels, supplemented in some cases by three-dimensional material (objects, models, scientific apparatus) to spread knowledge of scientific problems and of its programmes and projects in the sciences.

While the great development of travelling art exhibitions is recent, the idea is over a century old, its originator being one of the leading museums of England, the Victoria and Albert Museum in London. Similar activity dates in Canada from the early 1920s, travelling exhibitions have been employed in the United States for the past thirty years and they have become generally adopted in South Africa and Australia within the last

twenty-five years. Museums in the following countries all make use of travelling exhibitions and the majority can report some exchange of material as well. Australia, Austria, Brazil, Canada, Czechoslovakia, Denmark, France, India, Israel, Italy, Japan, Lebanon, Mexico, the Netherlands, Norway, Pakistan, Poland, the Republic of South Africa, Sweden, Switzerland, the United Kingdom and the United States of America.

The prototype in England was launched in 1850 with loans of works of art from the original Victoria and Albert Museum to the Central School of Design at Somerset House, and during the following two years the exhibition was successively shown at various provincial schools. From 1852 onwards these loan activities were directed by a separate circulation department. Its first efforts were concerned with the preparation of a comprehensive circulating museum comprising nearly 600 objects which toured for more than four years and was seen by no fewer than 307,000 people. After a second similar circulating museum was started on an even larger scale, the work of the department was concentrated on serving the needs of art students rather than the general public. Loans were made primarily to provincial art schools but the general demand for expansion of this service soon led the department to undertake again loans to museums and art galleries. The principle of lending a part of its treasures to the provinces has persisted ever since and today the Victoria and Albert Museum boasts the most comprehensive facilities for this purpose. Moreover, no limitation of value, fragility or rarity is placed upon the objects which are circulated, only those items which are defined as 'strictly

unique and of international importance' are excluded from the loan collections. Such an example on the part of one of the principal museums of the world is an inspiration to other institutions to create educational programmes of similar merit.

It is somewhat ironic that the war years produced the most vigorous exchange of cultural materials between countries. Surely a deeper understanding between peoples should assist in lessening tensions which ultimately flare into international conflicts. Presentation of the visual arts, the handicrafts, architecture, civic planning, scientific discoveries and achievements and the history of different countries offers a means of understanding more fully the aspirations, customs and character of different peoples. Moreover, the diffusion of knowledge for educational purposes in all fields (natural science, history, health, science, art, etc.) can be accomplished effectively through exhibitions. Visual presentation offers an international means of communication in which language barriers begin to disappear. Information can be exchanged, problems and subjects common to several nations can be studied and through such exhibitions can gain wide public attention.

One important development which has taken place since the museum loan service was introduced a hundred years ago is the completely 'packaged' travelling exhibition. This type of exhibition arrives with its own installation units ready to set up, its labels properly attached and its component parts so arranged as to be easily removable from their packing cases by the host museum staff. The sudden expansion of this type of service during the war, particularly through government agencies, and, since the war, to an increasing extent through cultural agencies operated abroad by many governments (United States Information Service, British Council, etc.) points to sincere interest in exchange programmes, and many methods of achieving first-rate exhibitions without the use of valuable, rare or fragile articles have been devised. Such shows now originate in museums, in art galleries, art schools, universities, clubs, and in industrial organizations and government agencies. They are often assembled by offices whose sole purpose is to collect material, prepare

it for display and pack it for safe shipment. A large number of commercial firms have recently come into existence in many countries, which specialize in the preparation of exhibitions for museums, for educational institutions and for their national governments. These exhibitions are used in the country itself, or are sent abroad to fairs and exhibitions and to organizations representing governments abroad, or to museums and galleries in other countries.

Since the war there has been an increased awareness of the necessity and the moral obligation to extend educational opportunities and to make cultural values more readily accessible to all, without regard to social distinction or geographic isolation. There have been efforts to provide in newer countries which lack great accumulations of art and other cultural treasures, even for their outlying areas, the advantages which centres of older civilizations enjoy.

One example of the value of travelling exhibitions to countries lacking large art collections is supplied by the report of the director of the National Art Gallery of New South Wales, Sydney, who writes that since 1944 pioneer efforts in Australia have been made with government support to bring exhibitions to remote country centres, 'to diffuse a knowledge of, and an interest in, the visual arts, and more particularly the Australian arts as they affect our people'. During the first three years, exhibitions had to be accommodated in town halls, school assembly rooms, churches, stores, barber's shops, restaurants and other available spaces. After five years of this service, however, a number of the centres now plan to build art galleries to accommodate travelling exhibitions. The government plans also to provide railway carriages, stripped of their furnishings, to be used as travelling galleries to serve centres economically.

The possibility of even more widespread use of the travelling exhibition as a medium for the dissemination of information has prompted the publication of this book. While it is confined to methods of displaying objects safely and effectively in travelling exhibitions, and to the systems which have proved successful to date of packing works of art or other material held by art museums, the principles may nevertheless apply to

institutions and organizations whose collections cover other fields such as history, science or natural science.

The material contained in the following pages is perhaps not representative of practices in use in all museums or circulating agencies, for it was necessary to rely upon the information which could be assembled from sources which commented upon the *Manual* when it first appeared in 1953 and additional information that has been supplied since that time by various experts and from exhibitions exemplifying new techniques. It is to be hoped that publication of this material will encourage others whose experience has revealed equally effective and satisfactory methods to send information to Unesco Headquarters in Paris as a basis for further, more complete and more inclusive studies in the same field.

THE ORIGINS OF TRAVELLING EXHIBITIONS

The circulating exhibition has come into being for two principal reasons: the usefulness of temporary exhibitions to museums, and the educational opportunities offered by a concentrated collection of material on one or more related subjects. The value of loan collections for smaller museums has been widely proclaimed. They overcome the problems of limited space, funds and staff which make it difficult for such institutions to prepare a series of temporary exhibitions. The continuous flow of first-rate material (whether of history, science or art) through their galleries provides a far richer and more varied programme than any that could be drawn from their own collections. Even the larger museums with access to almost unlimited sources have difficulties in presenting temporary exhibitions. Their staffs, concentrating principally on research and on the work of preservation, may lack the time or interest required to prepare a series of temporary exhibitions, which demand considerable research, documentation and publicity in addition to the physical work of setting up the objects for display. Further, museums have various specialities and one museum cannot cover all subjects. Consequently the travelling exhibition organized

by a number of participating museums, according to their individual specializations, permits the more efficient use of scholarship and skills for the benefit of all. The introduction of temporary exhibitions into the programmes of museums may also create, among the staff as well as the public, a more lively interest in the relationship between various cultures both past and present.

SOURCES OF TRAVELLING EXHIBITIONS

1. The richly endowed museum, overflowing with material, may wish to send out a series of travelling exhibitions which utilize a larger proportion of its permanent collections than can be displayed in its own galleries. Such exhibitions thus provide an active educational programme for the museum's own staff and at the same time enrich the provincial museum or other organization to which they are dispatched. In other words, both institutions offer a community service which is also to their mutual advantage.
2. A group of museums may co-operate in organizing an exhibition to be circulated to each in turn. Often this type of co-operation is prompted by the difficulty of financing a large loan collection assembled from many distant points.

The participating museums share the benefits of assembling a unique collection and divide the costs of travel, research, transport, packing, insurance, catalogues or other incidental expenses between them. The economy in costs can lead to higher quality, wider scope and more thorough documentation in the exhibitions themselves. These co-operative exhibitions are usually undertaken by fairly large museums which normally have adequate staff capable of handling installations individually adapted to their own galleries, and therefore no packing or installation of the easily re-usable kind is employed. This kind of co-operative planning allows the smaller museums both to extend their services and to organize more important exhibitions.

3. Sometimes the interest aroused in a large and important collection prompts a museum to prepare for circulation a similar

exhibition composed of reproductions of the original material. Such exhibitions make fuller use of the research required for the original collections and are often rented by institutions other than museums. Schools and colleges in particular can thus supplement their courses, or tie the exhibitions in with special lectures or other events, without incurring the risks involved in exhibiting and handling valuable objects and works of art; for the stimulating experience of seeing first-rate works, even in reproduction, is always educationally worth while.

4. Travelling exhibitions may be organized and circulated by an agency or museum specializing in this service. There are several such agencies in the United States of America: the American Federation of Arts, the Western Association of Art Museum Directors and the Museum of Modern Art, among others. In England, the Arts Council and the British Council, which receive government support, carry out a similar service abroad. Many museums in various countries including Australia, Brazil, Canada, France, Israel, Mexico, Pakistan, Poland, Sweden, the United Kingdom and the United States prepare exhibitions for national or regional circulation.

The provision of travelling exhibitions which maintain the standards set by museums and allow of installation with the least effort on the part of the subscribing institution demands careful preparation on the part of the agency. Such agencies, which are usually not able to call upon the services of a curatorial staff, or to take advantage of the research done for a museum exhibition, often employ experts to assemble, document and design their travelling exhibitions. In such cases, costs may run higher than for a similar show prepared by a museum whose staff can contribute time which would otherwise be costly. To avoid the costs thus incurred, agencies often take over an exhibition assembled by a museum, reorganize it and circulate it. Or, an agency may commission a museum to prepare an exhibition which it thinks would be widely used by other museums and like organizations.

5. Certain museums maintain a department of education whose staff is employed to assemble all types of materials for use by schools, clubs or other organizations. Interpretative exhibitions, often based upon objects in the museum collection may be shown in the museum itself. Travelling exhibitions, lectures, publications, slide-talks, filmstrips, motion pictures, radio and television programmes are prepared to permit the widest possible use of the educational material (Plate 35).

COSTS

The costs of preparing and circulating travelling exhibitions may be divided among participating exhibitors in different ways. The most frequent methods are:

1. If an institution has developed a programme of circulating exhibitions as a part of its educational activities, the costs of curatorial and administrative time are not usually reflected in the rental fees charged to subscribers. Sometimes museums are even able to absorb costs of preparation as well. In such instances, costs of transport and insurance are usually the only expenses assumed by the borrowing institutions. In order to keep these down to a minimum, the exhibition must be efficiently routed between exhibitors. Exhibitors may sometimes have to accept second or third choice of exhibition dates in order to enable the most economical tour to be arranged.
2. If an institution or agency's service of travelling exhibitions is organized on a self-supporting basis, all costs must be lumped together and a rental fee arrived at by dividing the number of possible showings into the total sum. An exhibition composed of photographs or other reproductions which have been purchased, rather than of originals on loan, can be extended over a longer period than is possible in the case of borrowed works, or advisable in the case of originals which might suffer from the hazards of travel. Thus costs to subscribers may be substantially reduced.

CIRCULATING AN EXHIBITION

In addition to finding a basis for loan fees, it is necessary to establish a schedule of exhibition dates well in advance of a tour in order to offer exhibitors maximum service. Announcement by letter to probable exhibitors is the most frequent method of arranging a series of successive showings. It is well to have in mind approximate dates and to ask exhibitors to make several choices in order to arrange an efficient schedule. Generally speaking, it is unwise to send a collection of valuable works of art or of historic objects or even of scientific specimens on tour for more than six successive showings without having the exhibition returned to its source for thorough checking of the contents and, if necessary, for repairs and repacking. This applies, of course, only to fragile or valuable materials. The period of the tour can be extended when materials can withstand continual shipping, or when arrangements can be made for thorough checking and reconditioning at a reliable institution on the schedule.

Normally, museums wish to schedule exhibitions for one month. But the period of time required to serve the public adequately depends on the size of the city and on the kind of public which the museum habitually attracts, as well as on what the borrowing institution can afford to pay for an exhibition. Each institution and each country must therefore expect to work out the best exhibition period according to local conditions and needs. Sufficient time should be allowed between scheduled showings for packing, transport, unpacking and reinstallation of collections. Factors which should be taken into account in determining the interval between showings are: size of the collection, complexities of installation, staff available for handling, unpacking and installation and geographical location of showings scheduled.

Organizations offering numerous collections for tour usually issue an annual catalogue describing the exhibitions. Subjects are discussed, contents outlined, space and installation requirements listed, weight of packed show given, terms of rental and costs stated, etc. From this descriptive material an exhibitor can usually judge the

value of a collection for his own use. Fuller information, including photographs, is often available from the circulating agency. Some museums are able to exhibit their circulating collections during the summer months, allowing subscribers to register their choice of exhibitions and dates at that time.

SUPERVISION OF TOUR

Since the principal problems in connexion with circulating exhibitions are packing, safe transport, the guarantee of arrival dates and assurance of practical and attractive installation under diverse conditions, constant assistance and supervision on the part of the circulating agency is required. The extent of this depends upon several factors: the staff available for this supervision, the value and rarity of the works of art on tour, the type of material to be displayed and the means of installation employed.

If the sponsoring institution has no staff member available to supervise the collection on tour, the exhibition may be turned over to an agency specializing in circulation problems.

Most subscribing institutions would prefer to have someone arrive with a loan collection, unpack and install it with a minimum of disturbance to their own routine. Such service is, however, not always feasible, although it is general practice among many museums in Europe and in Great Britain. Where distances between cities and towns are great, as in the United States, few museums can afford this procedure. In some countries government support supplies this service by paying the salaries and costs of travel for museum staff to accompany exhibitions on tour. Certain art museums are not only able to send a member of their staff with a collection, but also maintain trucks which carry the collection from place to place on the circuit. Large vans have been equipped also with lighting and permanent display cases so that the means of transport becomes the exhibition hall itself (Plates 34a and b). The advantages are numerous. The tour can go to any area without fear of encountering staffs inexperienced in handling valuable works of art, the material itself has to be installed only once, the organizing institution is able to maintain a constant check on

the condition of the material. The show is necessarily limited in scope, for the space inside a van is less than that offered by most galleries and the cost of equipping several such mobile galleries is considerable.

When it is impossible to send someone with the exhibition, the circulating agency should furnish the exhibition with detailed instructions, forms, and other information, so that a minimum of work is required of the host museum staff. This is necessary not only to allow the tour to run smoothly but also to provide the circulating agency with a complete record of the location, the condition and the use to which the material is being put. At each unpacking or repacking of the material a thorough check of the condition of each object should be made and a report made to the agency, advising it that the schedule is being either adhered to or modified.

Each new date on the tour approaches, the circulating agency may inform the gallery in which the collection is to be shown

of the number of boxes to expect, the approximate date of arrival, the method of shipment. A thoroughly detailed list of contents as well as full instructions for hanging or other installation should be given well in advance of a scheduled date in order to prepare the participating institution for specific or unusual requirements. Photographs of the exhibition installed in other galleries are often helpful to exhibitors in planning spaces and methods of display for the travelling collection in their own institution. Suggestions given should be sufficiently flexible to allow the host museum staff to exercise its own judgement in arranging the display.

Schedule sheet

To keep all such details in order a schedule sheet for each exhibition may be found valuable and could be used for any type of exhibition. A sample form is given below.

NAME OF EXHIBITION

Total value for insurance	\$50,000
Valuation per box for shipping purposes	\$50
Number of boxes in shipment	8
Weight of exhibition	1,200 lb.
Fee for exhibition	\$150
Period of rental	4 weeks
Number of items included	35 pictures
Space required	200 linear feet

Showing scheduled	Contract signed	Form I sent	Receipt received	Publicity sent	Form II sent	Shipment made
Museum of Fine Arts, Virginia 10 Dec. to 12 Jan. 1953	2 Oct. 1952	22 Nov.	5 Dec.	8 photos 30 catalogues 7 Dec.	4 Jan.	14 Jan.

With this information at hand, the circulating agency can keep a record of each step of the work as it comes up. When an exhibition is dismantled, such a sheet offers a

permanent file or index of the exhibition, number of catalogues sold, etc., for future reference.

Exhibition contract

A contract is useful to bind agreements between the sponsoring institution or circulating agency and the exhibitor and to discourage last-minute cancellation of schedule dates. Exhibitors will not alter plans without consulting the agency if they are bound to pay for an exhibition whether or not it is shown. The contract protects the circulating agency from loss of funds; fees are calculated to pay the cost of assembling and circulating an exhibition. It is sometimes difficult or impossible to fill a cancelled engagement for an exhibition if the cancellation is not well in advance of the scheduled showing.

Mailing forms and instructions

The mailing form reproduced in Appendix I represents a basic formula for travelling exhibitions as used, with individual variations, by museums and by organizations which circulate exhibitions. It obviates the necessity for a long letter describing the contents in detail and gives the exhibitor a ready comprehension of the various lists enclosed.

A similar form should be sent prior to shipment of the exhibition to the next exhibitor and gives the institution which will ship the exhibition advance information about packing, addressing the boxes and arrangements to be made for transport.

Samples of other types of enclosures are also reproduced in Appendix I, and their uses described.

Supplementary information

Labels. Various types of label available for travelling shows can be used to replace expensive catalogues. Picture labels or labels for small objects are usually merely identification tags. They may be quite concise, giving only indispensable data, for example for an art exhibition: artist, dates, country of origin, title of work, medium and lender, or, for an exhibition of natural science specimens, scientific (and possibly popular) name, provenance and lender.

Longer labels are needed to explain the meaning or educational intention of an ex-

hibition, and may contain biographical information, historical data or explanatory descriptions of material. For exhibitions of art, natural science, applied science, etc., consisting of separate works, specimens or pieces of scientific apparatus, to be shown either individually or in various groups, the labels are mounted ready to be placed on the wall in the proper sequence. If the exhibition is composed of photographic or other flat material mounted on large panels, the labels may be incorporated in the panels along with the items to which they refer.

Primary considerations are *clarity of presentation* (typewritten labels can be photographed and enlarged or typed on poster-size typewriters with large characters); *accuracy of information*; and *sufficient explanatory data* to supplement the visual material in the exhibition. Sponsoring institutions should realize that exhibitors who may be unfamiliar with the subjects treated in the travelling exhibition will appreciate the fullest information for use in publicity, for gallery lectures and for student visitors. Most circulating agencies request that their labels be hung with the exhibits as specified.

If labels are mounted on lightweight cardboard and provided with metal rings in the mounts for hanging, they can be used by each exhibitor throughout the tour without having to be replaced.

Publicity. In addition to sending exhibitors suggested forms for newspaper release it is often helpful to have other material on hand. Photographs of items included in an exhibition add interest to stories issued to newspapers and periodicals. Photographs can be taken by the circulating agency at the time the collection is assembled, the cost being included in the rental fee as an exhibition expense. If an exhibitor wishes a particular object to be photographed, however, such pictures are usually taken during his own showing. The usefulness of the particular picture may offset the additional expense involved. Many circulating agencies require that permission be requested before any object is photographed by exhibitors.

To make the greatest possible use of an exhibition, other means of publicity can be devised. The exhibitor may arrange a formal opening event for his own showing, plan-

ning it as a social occasion to bring in members of his own organization, or to increase the attendance at his museum by extending the invitation to other groups. He may plan a lecture related to the exhibition with slides which explain more fully the value of the material on exhibition. Many circulating agencies keep a file of slides to rent to subscribers, and often the agency can supply or suggest to lecturers motion pictures for special occasions.

Large posters or placards specially designed for the travelling exhibition may be placed outside the museum or gallery where the exhibition is to be held. If funds permit, smaller posters or handbills advertising the exhibition can be printed and distributed in the locality before the opening date.

Catalogues. If catalogues have been published for the original showing, at least one copy should be mailed to each subscribing institution to help the exhibitor with his publicity or his labels. Some agencies send more than one copy.

In countries where printing costs are high, the practice of preparing special catalogues for travelling exhibitions is less common. When a large loan collection is brought together, catalogues are usually published and the museum sending the exhibition on tour may offer the book to subscribing institutions on a consignment basis, the subscribing institution paying only for the copies sold. Any unsold copies that remain at the close of the exhibition can be returned for credit to the originating institution.

If the exhibition is not large, it is often preferable to document it sufficiently with wall labels so that the visitor need not buy a catalogue in order to identify objects or understand the message of the exhibition.

When an exhibition is prepared jointly by several institutions and then circulated among them, catalogues may be imprinted in advance with the names of the sponsors. If the order can be placed in advance of publication, each subscribing institution may have its own edition printed.

ASSEMBLY AND DISPLAY

There are more steps in preparing an exhibition which will tour several cities than there are in assembling a collection for a single showing. Furthermore, the circulating agency is held responsible not only for the character of the collection on tour, but for the clarity of presentation and the safety of the contents. Individual subscribers may augment the original collection for aesthetic or educational reasons, or to relate the exhibition to their own or local collections, but the basic quality is established by the original institution. This institution has a responsibility to itself and also to those lending material for the travelling exhibition. It is also responsible for quality and presentation to those who subscribe to the exhibition without first examining its contents. As an expression of this sense of responsibility, the Victoria and Albert Museum, the first institution to provide travelling exhibitions, states that its circulation collection in no way represents 'throw-outs, discarded as being unworthy of exhibition in London, or even second-class examples of lesser monetary value'.¹

The collections from the Victoria and Albert Museum are normally circulated only in England and installed by their own staff in the provinces (Plates 44a to e). Limitations may be imposed on material which is to be shipped overseas, or which has to be entrusted to less experienced hands. In such cases the principle is maintained that it is better to substitute a photographic reproduction of a first-rate work of art than to assemble collections of second-class material for tour. Many exhibitions of unusual merit and interest have been presented in photographic reproductions so that they could be shipped to institutions where expert and experienced staff were lacking.

Most agencies circulating art exhibitions divide their collections for tour into several groups. Exhibitors must comply with certain regulations to obtain collections in each class. One group may contain works of art of special value, for which exhibitors

1. Peter Floud, 'The Circulation Department of the Victoria and Albert Museum', *Museum*, 1950, Vol. III, No. 4, p. 300.

must guarantee particular care in handling. A second group, containing less valuable original works, may be made available to schools, universities, libraries, etc., where in the absence of trained personnel, responsible supervision will ensure the necessary care in handling. Other groups will probably contain prints, photographs or other reproductions—replaceable materials—which may be offered to institutions with less experience in handling works of art. In other museum fields than art there are few specialized circulating agencies and such differentiation of exhibitions would hardly be found. However, in all types of museums, small exhibitions of less valuable material available for educational loans can often be found.

Travelling exhibitions generally have to be unpacked and installed within a few days by persons unfamiliar with the contents, and then repacked and made ready for shipment in the same time at the close of a showing. Methods of presentation may vary considerably according to the contents of the exhibition and according to the circumstances in which it is to be shown. The most useful kind of installation for travelling exhibitions is therefore the prefabricated type, adaptable to different spaces and lighting conditions. Weight, which adds to shipping costs, places a limitation on the amount of supplementary material to accompany the exhibits themselves. Also, not all background features can be planned in advance. Lighting fixtures, for instance, are difficult to provide because of the variety of conditions (type of current, voltage, amperage, outlets, fittings, etc.) likely to be encountered in the areas where an exhibition may be scheduled. It is often necessary, therefore, to omit such fixtures and trust that the subscribing exhibitor will see that proper illumination is provided. If the type of electrical service available for an entire tour can be ascertained in advance, however, it is more effective when designing the exhibition to incorporate fixtures in the units where they are needed (Fig. 6).

Numerous solutions have been found for problems connected with the assembly and display of travelling exhibitions. Some of these, classified according to the type of exhibit, will be referred to in the following pages.

Extremely fragile glass, porcelain, pottery, old paintings (especially those on wood panels), old textiles, antique plaster and gilt picture frames, delicate biological specimens and scientific apparatus, fragile and irreplaceable historical objects and such comparable items, whatever the field represented, are usually excluded from travelling exhibitions because of the risk of damage from repeated handling or shipment.

Paintings

Paintings are usually framed for exhibition, and it has been found that they are safest in shipment when some type of frame is provided. The frames must have simple mouldings and be made of wood. The frame must project out from the surface of the canvas on all sides, and on the back as well if no stretcher is provided.

It is never advisable to send any type of moulded plaster frame on tour. Such frames are too easily broken and may endanger the canvases if pieces become loosened in transit. If a valuable frame must accompany a picture, it should be packed separately or be double-boxed (see packing instructions for paintings, Appendix II, and Fig. 18c).

Frequently, special frames are substituted for the permanent frames during the tour. These should be of simple but good design, strongly made, and should fit easily into slots built into the packing cases. They often add greatly to the appearance of the exhibition as a whole and because of their uniformity do not distract attention from the pictures themselves.

Watercolours, drawings, print., photographs or other works on paper

If such works are framed, the simplest narrow mouldings ($\frac{1}{2}$ in. to 1 in.) round or flat wood, strong enough to withstand repeated packing and shipping, should be used. Packing is greatly facilitated if uniform sizes of mats and frames are used. Oversize pictures should be framed in heavier mouldings. When exhibited, framed works are usually hung on walls or screens as in exhibitions of painting. Screens are necessary in many

museums where plaster walls, not equipped with picture rails, do not permit the direct application of picture hooks or nails to walls or mouldings.

Matting can be used to save the expense of wooden frames and transport costs. Items may be matted individually or in groups, depending on their size and the character of the exhibition. Even fragile and rare items may be treated in this way and, in fact, are often safer than when framed with breakable glass.

Unmounted material. If the work is unmounted, place the watercolour, print or drawing on a large sheet of cardboard. The cardboard mount should extend at least 4 in. beyond the edge of the work on paper (Fig. 7). Fasten the watercolour to the cardboard backing by attaching a fibrous paper such as Chinese rice paper to the top corners of the back of the watercolour. The rice paper tabs should be affixed with an adhesive which will not stain through; library flour-paste appears to be the most satisfactory. Fasten the rice paper tabs to the backing mount with the paste. This is done so that the watercolour or drawings will not slip away from the backing mount. (If such materials cannot be used, this step may be omitted altogether because the covering mat tends to hold the work in place sufficiently.) Then cut a transparent sheet of clear cellulose acetate or a plastic such as polyethylene, slightly larger (not more than 1 in.) than the drawing and attach this protective covering to the cardboard mount by means of cellulose masking tape (this is a tape, manufactured in various widths, covered with a non-water soluble adhesive of great strength). A paper tape is cheaper, although adhesive tape used in medical dressings will also serve the purpose. Cut a mat with a window in it the size of the watercolour and large enough to extend to the edges of the cardboard backing mount. Affix the window mat to the backing mount with paste so that the edges of the watercolour will be 'sandwiched' in between the covering mat and the cardboard backing, and the surface covered with the transparent sheet.

The transparent sheet must be rigid (thick) enough not to tear easily. The only disadvantage of this type of material is that some

kinds are not absolutely clear and a slight discoloration toward yellow or grey is noticeable against the work of art. Better quality materials will not noticeably affect the colour of the paper and the advantage of having the work 'sealed' into place for the duration of the tour may offset any slight discoloration.

When the work returns from the tour, the mat can be cut apart and the drawing removed without injuring or soiling its surface. The use of thin rice paper tabs to affix the drawings to the backing mount makes it possible to lift the watercolour or drawing from the mount without tearing the paper on which it is painted. Tiny fibres of the rice paper may adhere to the back of the watercolour paper, but no harm is done to the work itself. This type of mounting, recommended by museum print departments, requires skilled technicians to cut the mats cleanly and to mount the work of art carefully. It is not advisable to entrust this work to inexperienced hands.

Labels can often be incorporated at the lower left-hand corner or along the bottom of these mats, giving the show a neat appearance and avoiding the necessity of matching and hanging separate labels.

Protecting matted prints. A similar method has been devised for mats which are white or light in colour and which might be soiled by handling. The transparent sheet is placed over the entire surface, covering mat as well as the watercolour, the latter being mounted on a backing sheet and covered with a window mat as described above. The sheet is fixed to the covering mat by means of a linen, plastic or other adhesive tape which binds all three surfaces together around the edges. The work of art is again sealed in a dust-proof 'sandwich'.

If a clear plastic is not available glass may be used, but great care must be taken to fasten it into place thoroughly around the edges with the binding tape. Otherwise it is safer to return to the conventional method of framing with narrow wooden mouldings. If bindings are used around the edges, some means of hanging the mounted works must be provided. Metal 'grommets' (small metal eyelets or rings) can be punched through the surface of the mats. Tacks, nails, picture wire or cord can then be passed through the

holes without damage to the mats. If such fasteners are not available, linen tabs may be made by gluing together several sheets of linen (or any closely woven fabric) and cutting them into strips. The strips are then glued to the upper corners of the mats, preferably so that they do not show above the corners. These strips may be flat for use as a tacking surface, or looped for hanging with picture wire or cord. They are less durable than metal grommets and may pull loose from the back of the mat if they are not handled with care. But they serve the purpose if no better means is available and they can be replaced easily.

Mounting several prints on a mat. If several works of art of different sizes are to be mounted together, the method described above for unmounted material can also be used effectively (Plates 17, 28a, b and c). Labels can be mounted directly upon the mat surface. The use of painted paper or cloth letters for titles adds to the clarity of the presentation. Numerous small items can thus be grouped together for more effective display and more efficient packing.

Sealed airtight mounting. A variation of this last method is to use sheets of heavy transparent plastic (which is sold under varying trade names, lucite, perspex, plexiglass, etc., in different countries). The watercolour in its mat is placed between two rigid clear plastic sheets which project beyond the outside edge of the mat on all sides. A plastic filler strip $\frac{3}{4}$ in. wide and the exact thickness of the mat, watercolour and backboard is inserted on all four sides. This assembly must be carried out in a room in which the relative humidity is not less than 20 and not more than 68 per cent. The filler strip is then cemented to the front and back plastic sheets making a completely sealed plastic casing impervious to dust, water and humidity (Plate 36), which is almost indestructible even when subjected to exceptionally violent handling.

Mounting photographs. Enlarged photographs, made from negatives which are still available, need less protection. Photographs may be mounted directly, either individually or in groups, on heavy cardboard, wood, compo-

sition board or other rigid panels. If an enlargement is to be mounted individually, it is often advisable to extend the photographic paper on which it is printed beyond the edge of the mount, wrapping it around the edges and fastening it to the back of the mount. This will prevent the edges of the photograph from lifting or tearing loose from the backing mount. Rounding the corners of mounts or panels to which photographs are fixed will reduce the risk of damage in handling and packing.

Sculpture

The travelling exhibition of sculpture always presents problems of display because the exhibitor must have on hand enough pedestals the right size and height to show the pieces to advantage; if not, the circulating agency must provide them. The latter alternative is not always practicable and may be expensive unless means can be found to transport the exhibition by van. Collapsible pedestals made of plywood have been designed but even these are expensive to construct and ship (Fig. 8). Lighter weight materials are unsatisfactory as they are apt to bend or buckle with successive handling and packing. Exhibitors themselves have built simple pedestals made of inexpensive light-weight wood frames to which cardboard can be nailed, but they must be made sturdily to support the sculptures. These, however, are not suitable for travelling exhibitions unless the sculpture included is limited to very light-weight materials such as hollow clay, plaster casts, *papier-maché* or some of the less dense woods.

Easily-packed collapsible metal stands, such as the tripods used by photographers, might be experimented with for touring collections such as educational exhibits in which only replaceable items of no great value are used. They are not to be recommended, however, for sculpture of any great weight, rarity or fragility, because of the risk of their tipping over or being knocked into by visitors.

Very small sculptures may be mounted upon small blocks of wood which are then fastened to a wall panel, but such installations involve risks to which the owners must

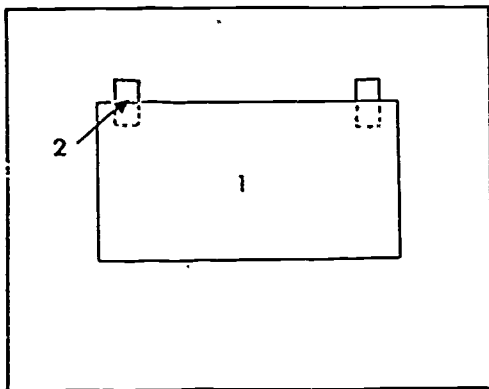

A

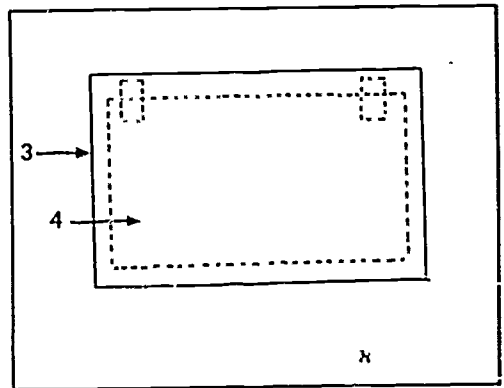

B

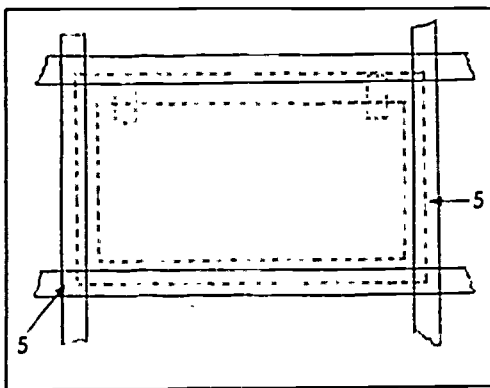

C

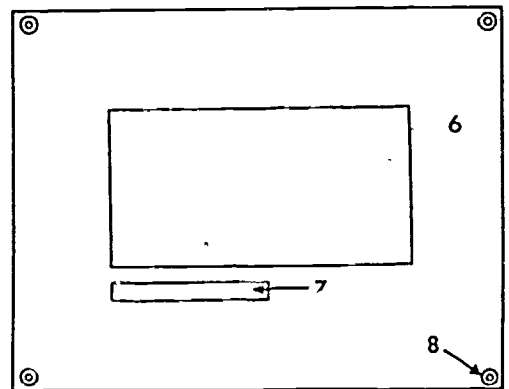

D

Fig. 7. Matting a watercolour with cellulose acetate or plastic covering sheet.

- A. Fasten the watercolour (1) to the backing mount with tabs made from rice paper (2).
- B. Cut cellulose acetate or plastic sheet (3) slightly larger than watercolour (4).
- C. Attach transparent sheet to mount with masking tape (5).
- D. Cut covering mat (6) the size of the watercolour and paste to backing mount, add label (7) and metal rings or grommets (8).

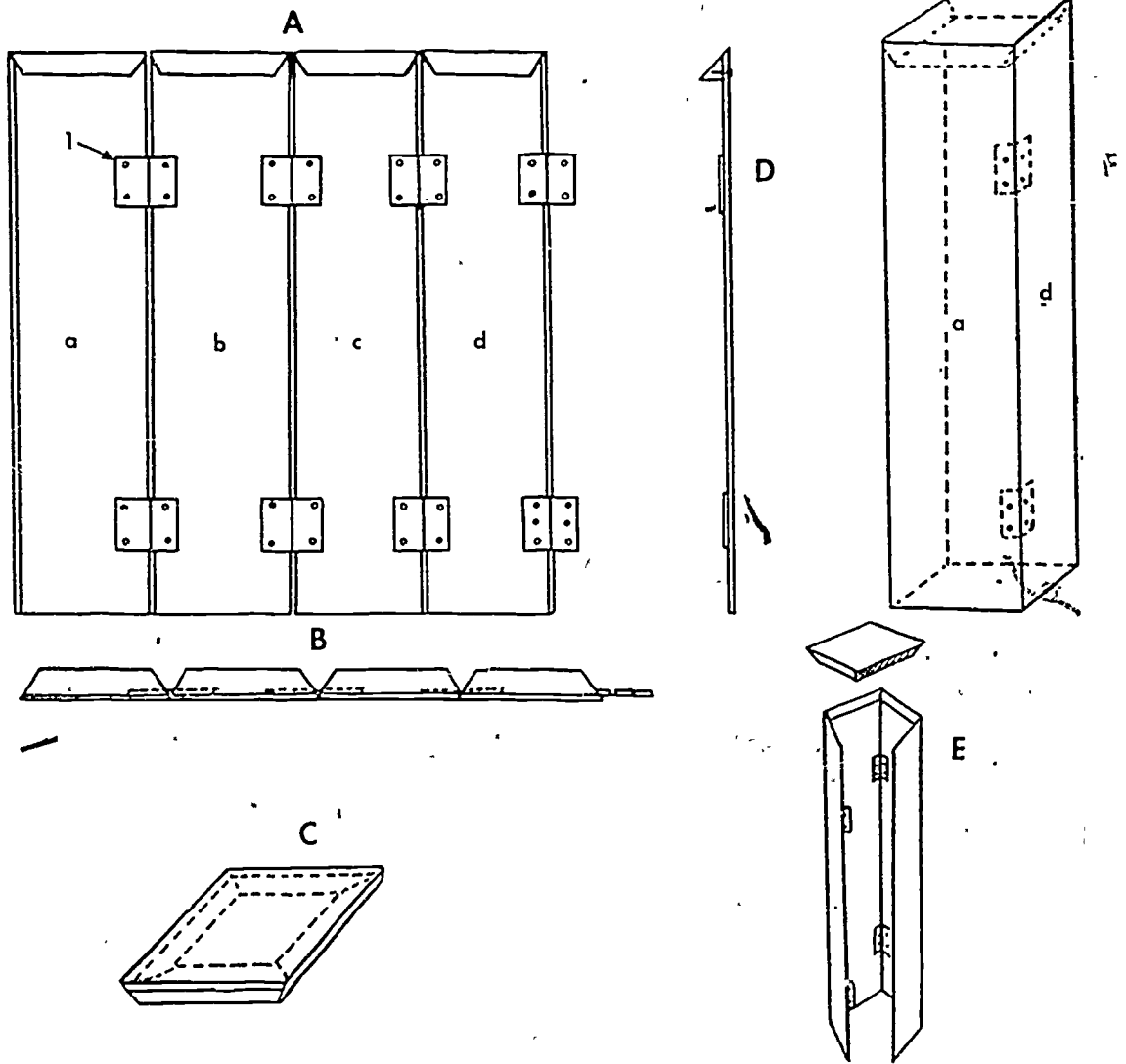

Fig. 8. Demountable pedestal made of plywood for sculpture.

- A. Four panels a, b, c, d, laid out flat, and metal hinges (1) screwed into place.
- B. Top view of the four panels showing the bevelled block of wood to hold the top piece in place (see also D, which shows the method of mounting).
- C. Top piece to be set over the four panels when assembled (the piece is made of $\frac{3}{8}$ inch plywood mounted on bevelled wooden blocks so that it fits securely in place when the panels are tightly hinged).
- D. End view of one panel made of $\frac{3}{8}$ inch plywood.
- E. View of pedestal showing final assembly with the hinges to be screwed into place.
- F. Assembled pedestal showing the final screws in place.

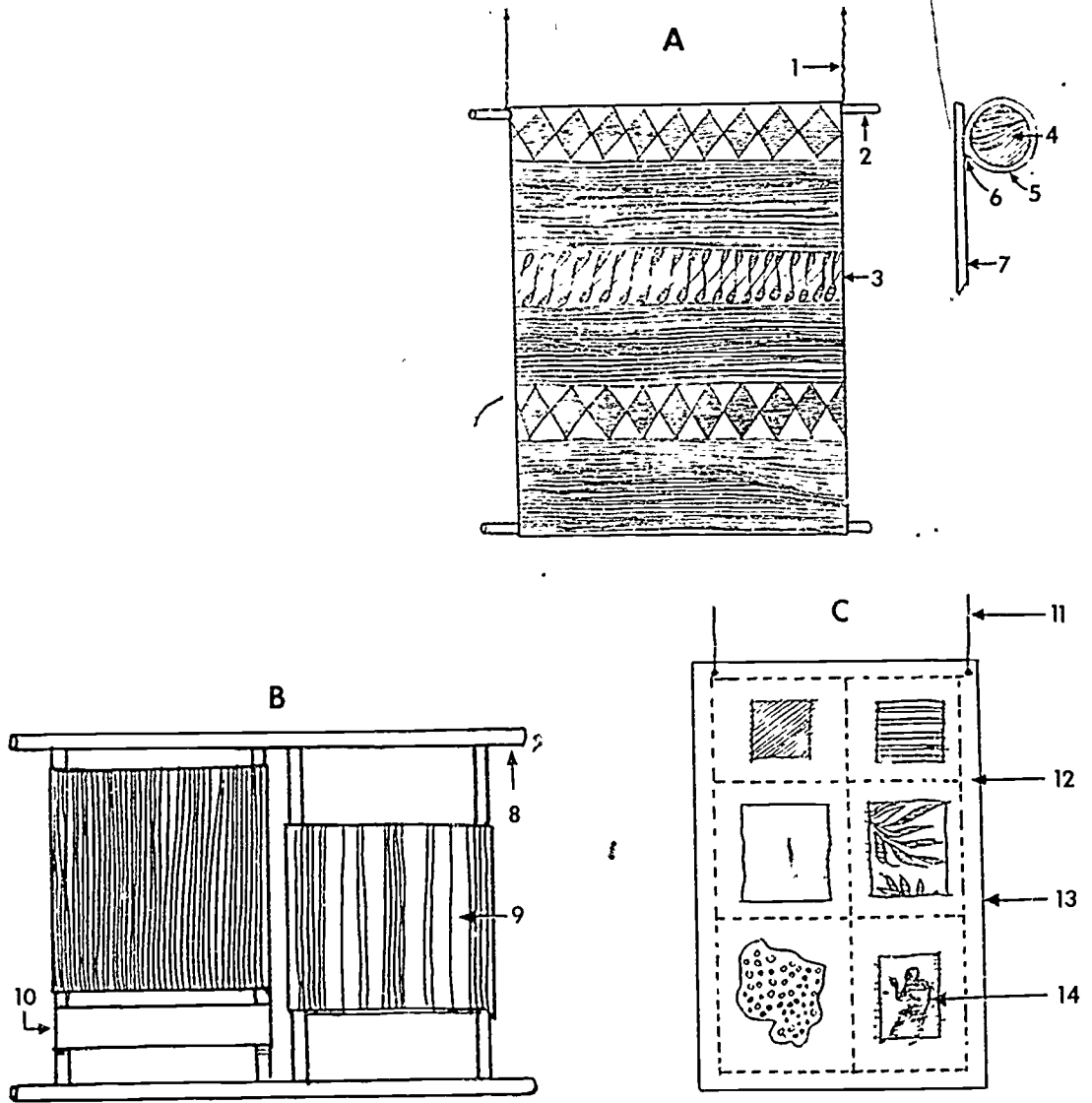

Fig. 9. Suggested methods of displaying textiles.

- A. 1, wire; 2, pole or dowel; 3, textile; 4, dowel; 5, tape loop; 6, sewing; 7, textile.
 B. 8, dowel or strip of wood; 9, textile looped on to dowels or strips; 10, label.
 C. 11, thin wire through celluloid; 12, sewing; 13, two sheets of celluloid; 14, textile.

agree before lending. The sculpture should be packed separately, the block installed on a wall panel or screen by screws attached through the back of the panel. The sculpture should be wired to the block so that there is no danger of its being removed during exhibition.

Small pieces of sculpture can be further protected in this manner by attaching a heavy plastic 'vitrine' (a transparent case) to the surface of the panel. Alternatively, the panel can be converted into a wall-case, with a plastic or glass face, the sculptures being attached to the back of the case.

Textiles and costumes

Many means have been devised for exhibiting textiles, but it is always difficult to show such exhibits to real advantage. Fortunately fabrics are fairly adaptable to different forms of presentation and they can also be shipped easily if they are not in any way fragile.

Large pieces—rugs, bed coverings, table linens or wall hangings—may be mounted on long wooden poles or boards which can then be hung from ceilings or walls by means of picture wire. An important point to note is that such textiles should always be mounted on the poles or wooden strips by sewing loops or tape at close intervals on the back of the textile through which the wood piece may be slipped. Smaller pieces may be similarly fixed to dowels or sticks attached to both top and bottom edges to hold the fabric flat (Fig. 2). If both sides of a fabric are to be shown, the piece may be mounted between two narrow wood frames and the frames hung from the ceiling or placed on simple wood stands like screens.

Costumes are usually best displayed to show the way in which they are worn. Simple outline figures may be made of demountable pieces so that they can be packed flat. Often, however, to facilitate packing, costumes are simply displayed on walls or attached to panels (Plates 37a and b).

Fragile, rare or unique items should be treated like paintings or drawings, mounted under glass, rigid plastic sheets or heavy cellulose acetate in frames or mats. An attractive method of mounting very small

and rare or fragile items, such as examples of ancient weaving from Egypt or Peru, is to place them between two transparent sheets which are stitched together at intervals around the textile samples (Fig. 9c).

Three-dimensional objects

This category includes small items such as tableware, silver, pottery, small carvings, decorative objects, toys, jewellery, ivories, industrial design, scientific specimens and apparatus, etc.

Such items can be well displayed in many ways, depending upon their size, value and fragility.

Wall panels. Some items can be mounted directly on panels which are hung like pictures from a wall (Fig. 10a and Plate 24b). If valuable items are mounted on the panel, they may be wired to the surface, and protected by attaching a sheet of heavy plastic (plexiglass or lucite) of equal size two or three inches away from the surface of the panel. The protective sheet is bolted to the four corners of the panel with metal posts. The panel affords the protection of a wall-case, is simpler to construct and is lighter in weight.

To accommodate three-dimensional objects, hinged shelves can be attached to panel so that they fold flat for shipping.

Another variation is a panel which has a protecting frame fastened on a slant so that at the top it is perhaps 1 in. deep and at the bottom 7 or 8 in. deep, forming space above for flat material and, below, a shelf for objects in the round. Such frames can be planned so that they fit one against the other to make a rectangular box which fits snugly into a shipping case (Figs. 10b, c, and d).

Demountable tables. Objects may be affixed to the table tops or packed separately and placed thereon by each exhibitor. The method depends upon the size and nature of the objects (Plate 38a).

Demountable cases or wall-cases. This method is best for objects which must be protected by glass or heavy plastic covering. Such cases are usually small for ease of handling

A

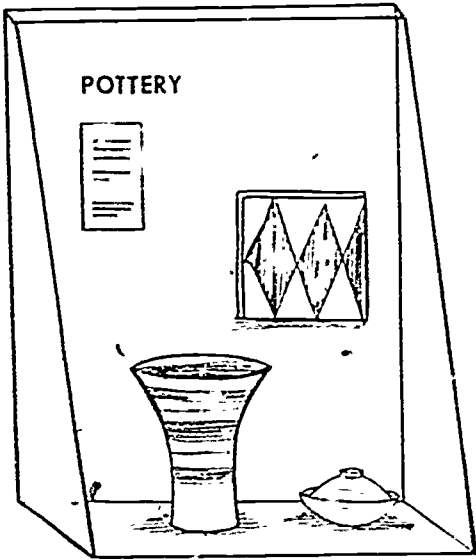

Fig. 10. Wall-case for displaying three-dimensional objects.

A. Frame showing objects on base; label, letters and flat objects on back of case.

B. Similar type of case of different proportions.

C. Such cases may also be placed on a table or a stand.

D. Two cases placed together for packing.

B

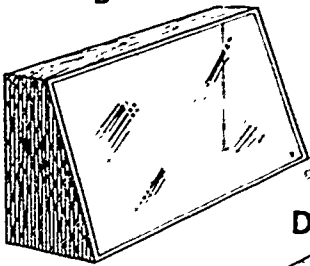

C

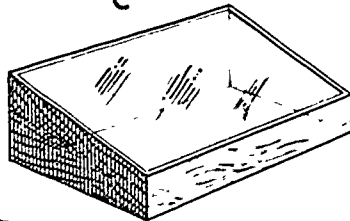

D

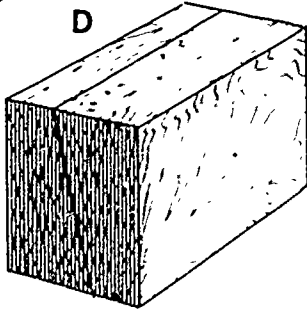

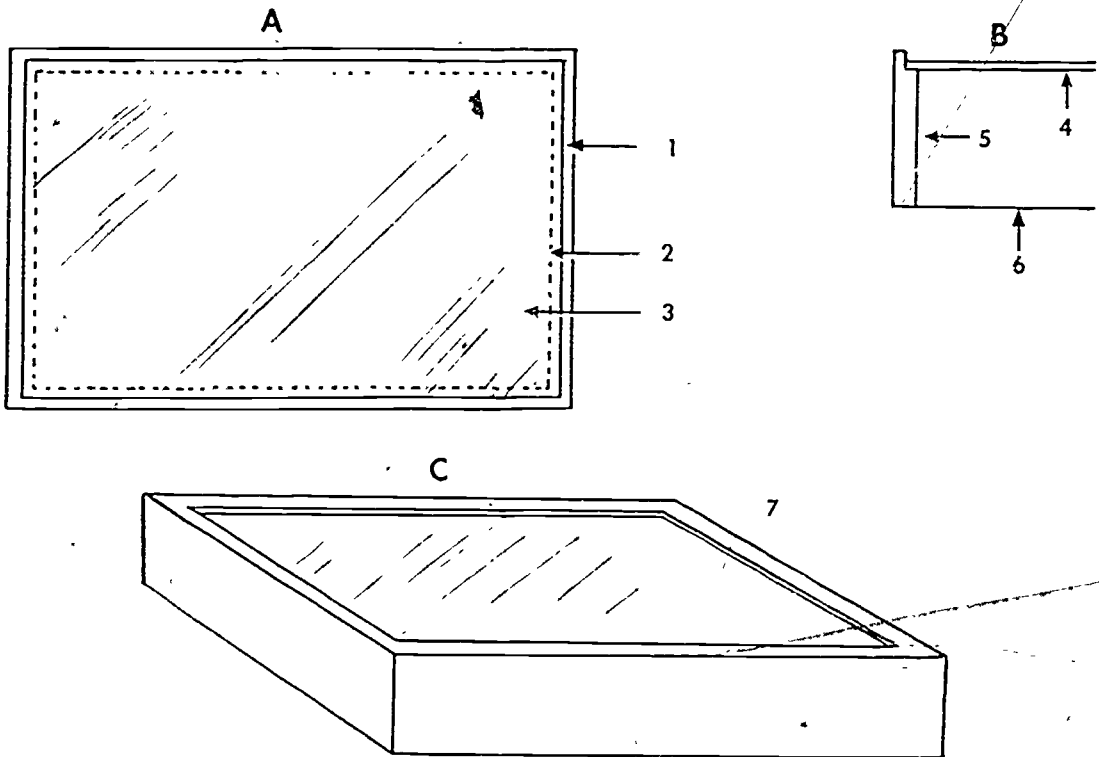

Fig. 11. Table-case with removable glass cover.

A. 1, top of frame; 2, projecting edge of frame to hold glass; 3, glass.

B. 4, glass; 5, profile of side of case; 6, bottom panel.

C. 7, three-quarter view of table-case.

and for safety in shipment. The table-cases are usually made of light-weight woods, the surface on which the objects are displayed being polished, covered with a fabric or painted—whatever best sets off the items exhibited. If the specimens need to be protected by glass covering during exhibition only, a sheet of glass, shipped separately, can be set into a recessed edge formed by the sides of the case (Fig. 11).

Demountable installation units. The manufacture of unit systems of posts, shelves, panels or table surfaces which can be assembled by each exhibitor into a completely free-standing structure will be more fully discussed under 'Panels and free-standing display units' (page 76). Excellent organization of an exhibition can be effected by means of such units, lighting incorporated, so that an entire room seems to be created quite independently of the space in which it exists.

Attention is called to this type of display for small objects because it permits maximum flexibility and combines the advantages of tables and wall panels (Plate 38*b*).

Glass cases. When trucking is available for transport, glass cases or 'vitrines' may be safely used for travelling collections. Hand-some cases, easy to install, have been developed for small objects by numerous agencies, especially in Europe and in Great Britain where motor transport is widely used.

Books

Depending upon their rarity value, books may be treated like small objects—mounted upon rigid panels, placed on demountable table or in wall-cases, or framed like pictures under glass.

If it is possible to display unbound pages of a book, these pages may be treated like watercolours or other works on paper, and framed with glass or mounted with celluloid coverings in mats. An effective method of displaying a series of pages from a single book is to mount each page against a cardboard background, cover it with a transparent sheet and bind the edges together with adhesive tape. Correlative mounts can then be glued together at one edge with

heavy canvas tape hinges and displayed like an accordion folder on a shelf.

Bindings should be exhibited in table-cases. Small containers of water should be placed inside each case to ensure sufficient moisture content so that bindings will not crack or flake from drying out.

Posters

Four methods have been found equally satisfactory for displaying posters. The choice is again made according to the value of the work. Means of exhibiting and weight of shipment are also factors to be considered.

Unique and valuable examples of poster art. A poster may be framed under glass as if it were a painting. A smaller size of glass is required if the poster is mounted without a mat, as is usually the case.

To decrease the weight of a shipment and avoid the hazard of using glass, the poster may be covered with a sheet of clear cellulose acetate or plastic. The poster is placed on a sheet of cardboard of equal size and the entire surface covered with the transparent sheet, the edges being bound with strong adhesive tape. Linen tabs or metal rings may be affixed to the back of the mounted poster for hanging. This method is not suitable for mounting very large posters because the sheet is apt to buckle and pull away from the binding tape around the edges. Posters more than 3 ft. × 4 ft. in dimensions are better mounted by one of the methods mentioned below.

Replaceable contemporary posters. A simple and economical method is to mount the poster on heavy cardboard or composition board. Metal grommets or rings placed in the corners enable exhibitors to hang them easily from picture mouldings or tack them to the walls. Sometimes collapsible framing systems are sent with posters in order to display them independently of wall surfaces.

In order to decrease the weight and bulk of a shipment of posters, they may be mounted on heavy linen or canvas. The edge of the cloth should project an inch or more at top and bottom to permit insertion of the hangers without damaging the poster itself.

The use of cloth backing permits the poster to be rolled for shipment so that only a small packing case is required. The posters can be tacked to walls, hung from picture wire or attached to free-standing framing systems with cord looped through the metal rings and pulled taut so that the poster remains flat (Fig. 12).

Furniture

In general, furniture has to be treated like sculpture, mounted by each successive exhibitor on platforms, pedestals or directly on the floor. Light-weight modern chairs of a durable character can sometimes be mounted directly on wall panels to call attention to some special construction feature.

More often, exhibitions of furniture design are composed of enlarged photographs, supplemented by only one or a few small pieces of furniture neither too fragile nor too bulky for easy shipping. When motor transport is used, large pieces which do not require boxing can be included, but for shipments by rail, boat or air such pieces are usually eliminated.

Model rooms have been devised with miniature pieces of furniture exemplifying the character of a given period of design. Such collections are often fragile and someone is needed to accompany the exhibition to make repairs, to supervise all packing and handling and to install the model rooms. These exhibitions have been remarkably successful, however, and the additional cost of preparation and maintenance can be at least partly offset by entrance fees paid by visitors.

Architecture and civic planning

Careful reproductions of buildings on a small scale are often used for exhibition purposes in the same way that model rooms are used to give an idea of the architectural style of a period. As such models are usually fragile and difficult to repair, their use in travelling exhibitions is restricted.

Pedestals on which models can be shown must be devised by each exhibitor. Scaffold frames may be constructed and covered with

cardboard, paper or cloth. Some circulating agencies suggest the use of packing-cases and include a cloth covering for use when the models are displayed. The disadvantage of this method is that the model rarely stands at the proper eye level from which a building should be seen.

Small, light-weight models can be shown on shelves fixed by braces to a wall. Shelves and braces may be shipped in the case with the model. Free-standing display methods are usually preferable, however, because many museums cannot nail braces against their walls (Plates 39a, b, c, d, e).

Sometimes it is necessary to protect the model from curious fingers by covering it with a glass or heavy plastic 'vitrine' or box. Again, it is difficult to ship such items by rail and they are not usually included unless shipment can be made by van.

Architectural exhibitions may also be composed of enlarged photographs, labels, maps, etc. Small sections of buildings, structural features or samples of materials can be mounted directly on wall panels. Civic planning can be demonstrated with small block units resembling various types of buildings. Educational displays of this kind containing photographs and diagrams as well can be conveniently packed in boxes with shelves, which open like closets (Plate 39f).

Large models used to represent whole areas, such as civic planning exhibitions, are often made in sections for ease in shipping. They can be assembled as a mural display, the sections being hung against or mounted on a wall panel, or shown flat on a table base or on the floor.

Panels and free-standing display units

Like architecture, many subjects for display can be treated in photographs, colour reproductions or small three-dimensional objects mounted directly on panels. Because so many museums were built to house only permanent collections, little thought being given by their builders to providing continuous wall space for the temporary presentation of two-dimensional material on loan, they find it difficult to take advantage of travelling exhibitions. The general need for

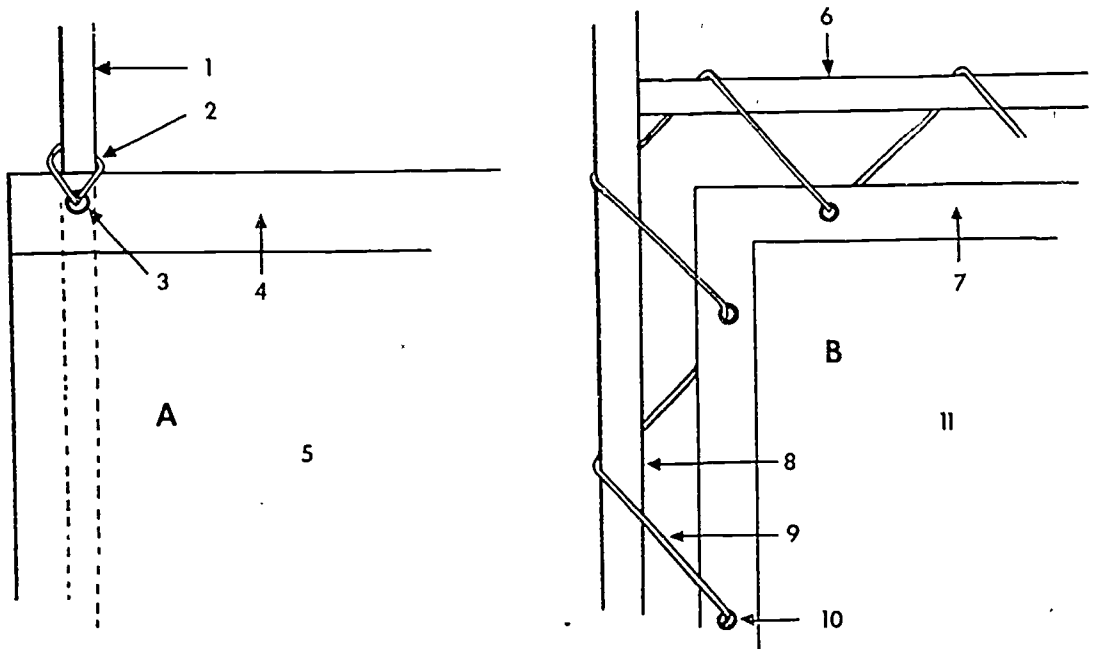
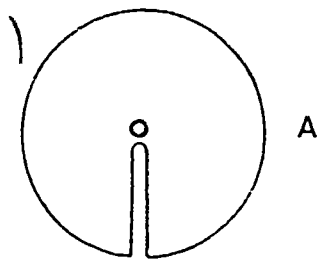
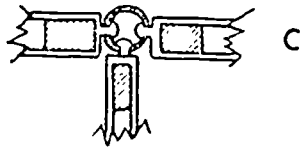

Fig. 12. Methods of attaching linen-backed posters to frame.

- A. Detail showing poster attached to support at top: 1, vertical support; 2, cord; 3, metal ring or grommet; 4, linen mount; 5, poster.
- B. Detail showing poster attached to support at side and top of free-standing frame; linen mount projects at side and top of poster: 6, horizontal support; 7, linen mount; 8, vertical support; 9, cord; 10, metal ring or grommet; 11, poster.



A



C

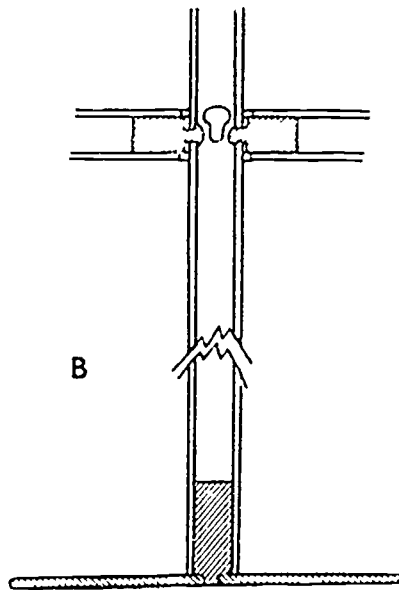

B

Fig. 13. 'Struc-Tube', a demountable framework designed by George Nelson and manufactured by Affiliated Machine and Tool Company, New York.

- A. Plan of base.
- B. Vertical section. Hollow tube fits over centre post attached to base.
- C. Section of centre post showing how horizontal tubes are joined to post.

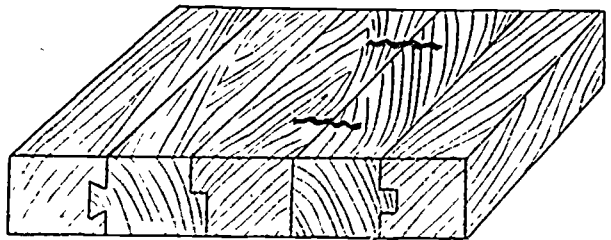

Fig. 14. Joints used in box construction. From left to right. Linderman joint, ship lap joint, butt joint, tongue and groove joint.

systems of displaying material which are independent of the spaces available has prompted a series of ingenious solutions, primarily designed by architects. All are based upon methods of creating free-standing walls, cases, pedestals, panels, shelves or tables on which exhibitions may be presented.

While panels can, of course, be hung like pictures against a wall, it is often difficult for an institution to provide sufficient unbroken wall space to allow for the proper circulation of visitors from the beginning to the end of an exhibition, especially when a particular sequence of panels must be maintained. For such exhibitions, panels mounted on vertical supports which can be set up in open spaces are more useful. The exhibitor can place the exhibition so that some flexibility is allowed in the sequence of panels to accommodate entrances, exits, patrols of guards and to create open spaces in which groups may gather for talks or lectures on the materials displayed (Plates 3, 23, 28a, b and c, and 39a).

Important considerations in the design of portable installation units are ease of packing and lightness for shipping, speed of assembling and dismantling, and ease of maintenance. But as an architect has pointed out, most exhibition units are 'designed primarily from the standpoint of the materials to be exhibited and not from the conditions under which they are to be shown' (Joseph Carreiro, William Daley, Charles Quillan on 'Flexible Display'). Architects have therefore given particular thought to designing unit structures which will be capable of presenting a variety of exhibitions under a

variable number of physical conditions. A number of these solutions are discussed below. Some of these systems are now being manufactured in the United States so that units can be purchased by an exhibitor or circulating agency and put together in whatever groupings the exhibitor needs to accommodate his display. Moreover they can be used in different combinations for various exhibitions so that a set of units may serve for successive exhibitions sent out over a period of years (Fig. 13 and Plates 2a and b, 12, 24b and 33b).

Panels are usually made of plywood, pressed wood, composition board or other light-weight material painted in attractive colours, perforated or covered with cloth. Exhibitors can display pictures, photographs, posters or other flat materials on the panels. Architectural models, sculpture, books or other three-dimensional objects of various kinds can be packed separately and hooked on to panels, or they may be shipped as an integral part of the panel if their nature and condition permit.

Certain imaginative designers have combined units manufactured for entirely different purposes into display systems for exhibitions at very moderate cost. The success of such efforts and the fact that structural units for display purposes are now being manufactured marks a step in advance toward ease in assembling and packing both travelling installation and the objects themselves. It is possible that in the future many more exhibitions will be organized by museums for circulation if such materials can be made available at reasonable cost (Plates 16a and b, 33a and b, 39a, b and d).

PRINCIPLES OF PACKING

INTRODUCTION

Because the protection of each work of art presents a different problem, it is impossible to set out rules which can be followed with complete success in every instance. There are, however, certain general principles which apply to packing all materials for travel and which experienced packers have agreed are essential. But only experience and knowledge of good packing can guarantee results. Thus, a general programme of training for museum personnel in the problems of packing, handling and transporting works of art can accomplish far more than any manual of instruction, however detailed and complete. The printed word cannot take the place of experience.

Since the objects will be unpacked, handled, and repacked by persons not familiar with them, it is best to use standard methods where possible. The outline of packing procedures given here is based on an article entitled 'Packing Problems and Procedures' by Robert G. Rosegrant, which appeared in the January 1942 issue of *Technical Studies in the Field of the Fine Arts*, now no longer issued, but formerly published by the Fogg Art Museum, Harvard University, Cambridge (Mass.), United States of America. Another excellent work on the subject is entitled *Safeguarding Works of Art* by Robert P. Sugden of the Metropolitan Museum of Art, New York (see also Appendix II).

So as to classify packing procedures according to practices already in use in a number of museums, the seven classifications set out in the two publications mentioned are being followed. The procedures have, however, been modified to apply more

specifically to travelling exhibitions than to shipments of single works of art on loan, going to and from a single destination. Objects in each classification require a somewhat different packing procedure, but the following general rules apply.

GENERAL RULES

The form for the outline of general rules has been taken from a report prepared by a committee of the American Association of Museums on the packing and handling of objects. Technical information on construction of containers has been further amplified by data supplied by the United States Department of Commerce in their publication *Modern Export Packing*.

Cases

Construction. Seasoned (air-dried) wood, aged to a state of maximum stability, $\frac{7}{8}$ in. to 1 in. in thickness, free of bad cross-grain or knots, is recommended for the construction of shipping containers, to travel by rail or boat. Open crates are never used for shipping works of art. Containers must be solidly constructed, lumber should be tongued and grooved or otherwise matched (Fig. 14).

Interior dimensions should be from 4 in. to 6 in. larger than packaged contents to provide space for resilient padding. The exterior of the case should be reinforced by cleats and riding battens (Fig. 15). Cement-coated nails should be used since they have a greater resistance to withdrawal from wood than untreated nails. Wood may be

coated with paraffin to prevent moisture escaping when humidity changes take place.

Small cases for lightweight objects may be made of $\frac{1}{4}$ in. to $\frac{1}{2}$ in. plywood reinforced with heavier lumber, particularly on the ends (Fig. 16). Unless exhibits are heavy, such boxes are usually used for transport by air.

Cover attachment. Screws should be used for cover attachment where cases are constructed for only a few trips; bolts are preferable when successive shipments are foreseen. *Nails must never be used to attach covers of cases for travelling exhibitions.* Successive nailings tend to split the wood and weaken the construction of the packing case. For shipment overseas, some type of lock may be used, and metal strap sealing is advisable in order to hold the case firmly together and help to distribute shock which would otherwise be absorbed at the point of impact (Fig. 17).

Waterproofing. Containers should be lined with waterproof paper, tacked or stapled down, and with overlaps sealed into place with gummed tape. Side and end papers should be long enough to fold over to form a cover for contents.

Interior partitions. Separation battens should be used when more than one object is packed in a single box. They may be made of corrugated board or heavy lumber, depending upon the weight and shape of the objects. These battens provide interior reinforcement and a partial floor or wall for the different objects so that they cannot shift when the container is moved (Fig. 18a).

Board battens should have cleats attached to them at each end. The cleat furnishes a means of attaching the batten to the outer container without nailing it directly to the wall of the packing case, thus distributing any shock (Fig. 18b).

If used to hold paintings in place, battens should be padded with excelsior pads and not nailed or otherwise directly attached to the picture frames. When board battens are used to support paintings, heavy corrugated board of the same dimensions as the interior of the case should be placed either over or under the battens. A separator sheet should also be placed beneath the first object packed and over the last one in the case.

(Figs. 18a and c). When used to support heavy objects (sculpture, furniture, etc.) the batten should be padded with excelsior padding, foam rubber or felt, wherever it comes in contact with the object.

Size. Risks increase in proportion to the number of objects in each case. Boxes should not be heavier than one man can lift, unless the circulating agency knows that each exhibitor has sufficient staff or equipment to handle heavier cases. Cases must be strong enough, however, to carry the loads intended for them. It is better to make additional cases than to overload those available. For safety and convenience, handles should be of metal or strong rope.

Padding and wrapping

A rule of first importance, and one to which all museums and packing experts agree, is that objects must 'float' in the packing case and be free of contact with the walls or with other objects in the case. This is to prevent the transmission of vibration or shock from the outside container to the packed object. For this reason, battens or braces to hold objects in place must not be directly attached to any item, but separated from it by some shock-absorbent such as excelsior padding, foam rubber, felt or other resilient lining such as some of the new plastic foams. The padding should always be firmly affixed. If tacks are used, they must be long enough so that they will not work loose during shipment. It is better to attach pads with adhesive tape or to staple them, than to risk using tacks that might become loosened. In cases constructed for repeated shipment of a specific object, the padding can usually be securely built in; it should be from 4 to 6 in. thick between the objects and the wall of the packing case and packed in tightly enough to prevent settling toward one side of the case.

All padding material should be wrapped and sealed in self-contained units. The use of loose excelsior, cotton or other padding is permissible only when objects are already boxed or wrapped in heavy paper or cloth.

The padding material must be resilient. For single shipments shredded newsprint or

Fig. 15. Typical box construction.

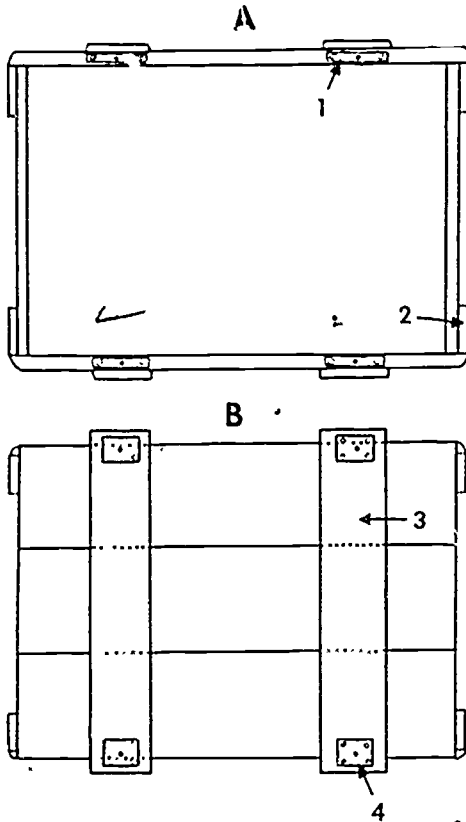

- A. Top view, case open. Metal plate (1) screwed into side. Hole in centre to receive bolt attached through the cover plate. Batten (2).
- B. Top view, cover in place. Batten (3). Metal plates (4) to fasten cover.
- C. Three-quarter view of case showing siding battens and reinforcing battens.

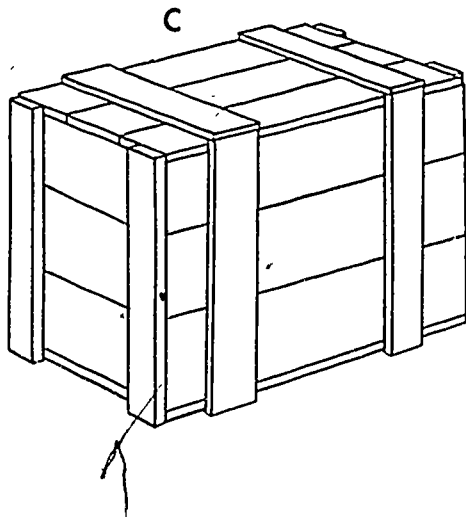

Fig. 17. Methods of applying metal straps.

- A. One strap: place at centre of length.
- B. Two straps: place one-sixth of length from each end.
- C. Three straps: place centre strap equal distance from two end straps, latter placed one-sixth of length from ends.
- D. Metal straps placed over battens.

Metal bindings act perpendicularly to the grain in the sides, top and bottom of a case. They should be placed tightly enough to cut into the wood so they will not loosen if the box shrinks.

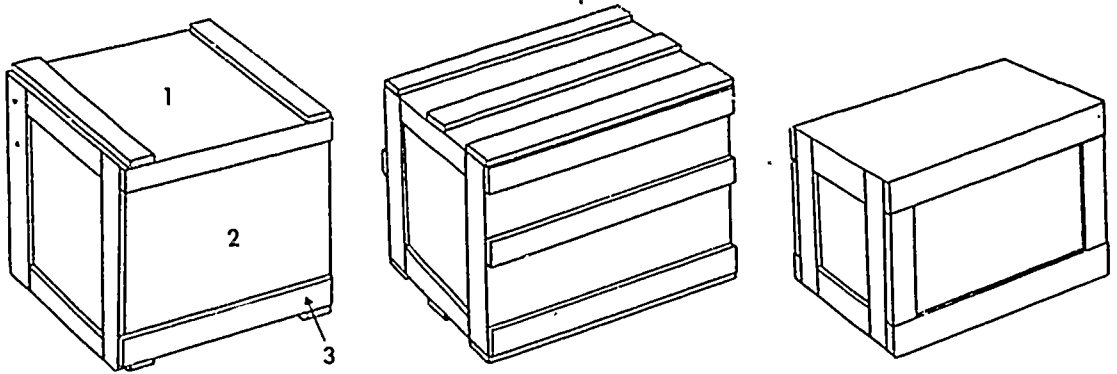
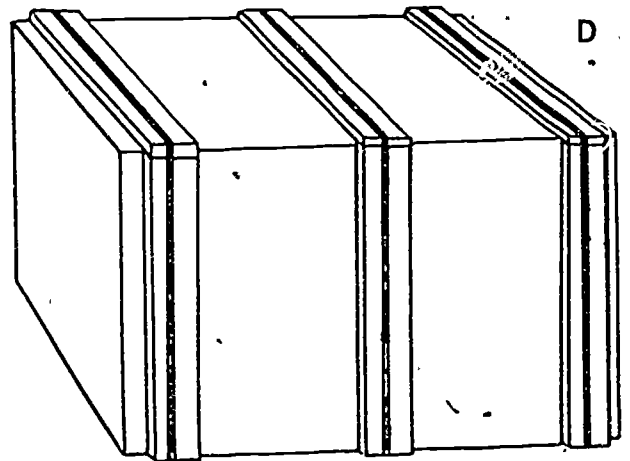
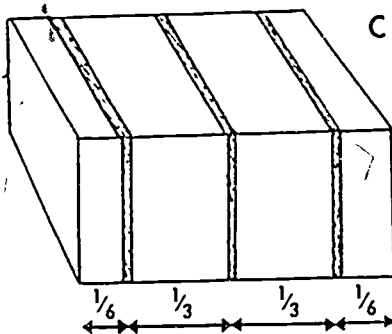
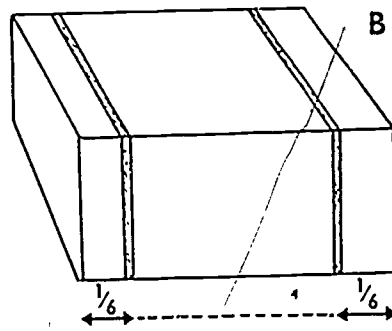
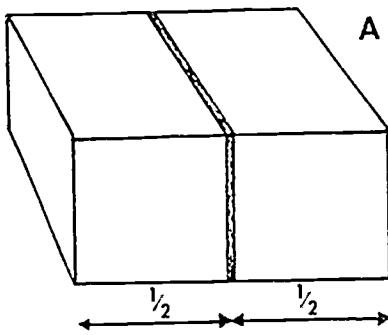

Fig. 16. Three types of plywood cases with reinforcing battens of heavier lumber. 1, 2, plywood; 3, heavy lumber batten.



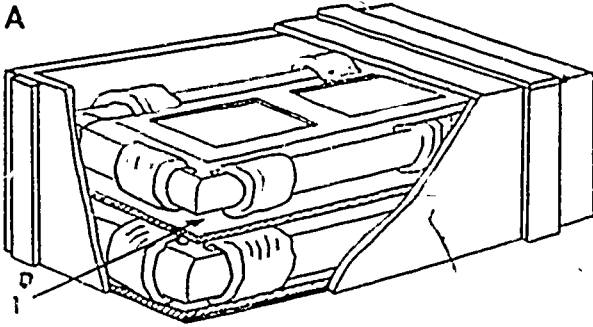
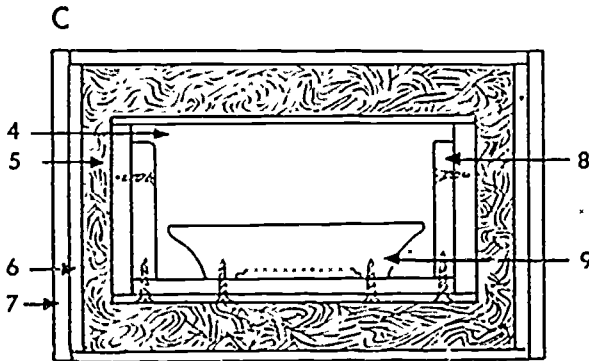
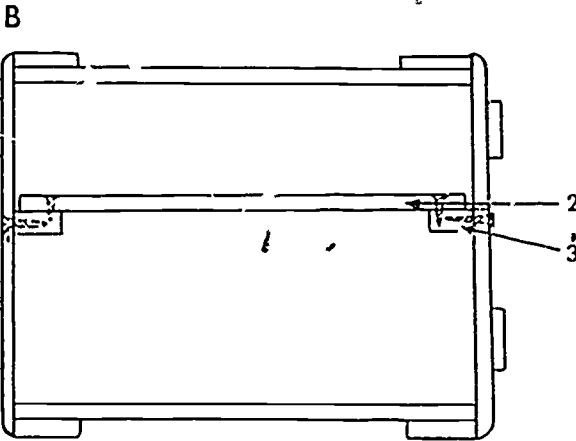

Fig. 18. Interior partitions.

A. Corrugated board batten. Box cut away to show corrugated board battens (1) between pictures.

B. Top view, box open. Lumber batten or brace (2) screwed to cleat (3). Cleat screwed to wall of box.

C. Side view showing fragile frame and painting in inner box (4) 'floated' in excelsior (5). Outer box (6). Batten (7). Cleat screwed to box (8). Frame screwed to cleat (9).



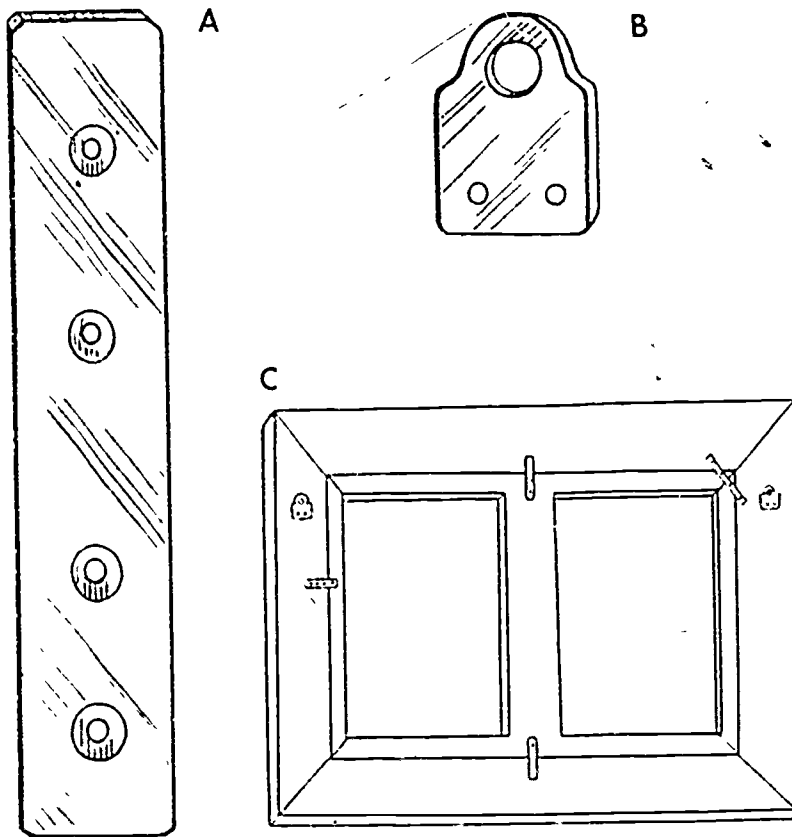

Fig. 19. Metal straps and plates.
 A. Metal strap, actual size.
 B. Picture wire plate, actual size.
 C. Straps and plates in place.

waxed paper may be used, but these materials are not recommended for travelling exhibitions because they tend to absorb moisture and to mat, losing their resiliency after several trips. Straw and sawdust also absorb moisture easily, indeed their presence in packing containers is forbidden at ports of entry to many countries. Excelsior seems to be the most satisfactory for general use, it is the least expensive, stands up to continued use over a long period and retains its resiliency. It should be fresh, however, at the start of a tour so that its resilience is at a maximum and care should always be taken to seal it off from contact with objects packed, for fragments tend to work their way under the frames and glass of prints and into crevices of other objects.

Artificial foam made of cellulose or rubber has been effectively used for padding but often needs a protective covering of muslin or some other inexpensive cloth. If foam rubber is allowed to come into direct contact with certain polished metals its sulphur content may cause stains which are difficult to remove. Foam rubber may sometimes stick to a delicately encrusted surface, for example, old glass, removing small particles and causing injury to the surface. Unless used in great quantity, synthetic foams are not satisfactory for heavy items for a shock against the outside container will be transmitted directly to a heavy object. Their use without excelsior should therefore be carefully considered in relation to the weight of the objects packed. They also cost more than excelsior, although the expense may be justified by repeated use, chiefly as padding on braces for paintings, sculpture or other heavy objects. The brace functions as the support, and the foam holds in suspension the objects packed within the container.

All fragile surfaces, such as varnish, paint, etc., should be protected against contact with any loose-padding material and paper-wrapped pads are equally injurious to such surfaces. An interior package, dust-tight, moisture-resistant, rigid and free of fragile surfaces should be made for any object of this kind.

Only tissue paper, waxed paper, mulberry paper or soft cloth should be used to wrap delicate objects such as jewellery, old glass,

ivories, painted potteries, etc. Cotton batting is apt to adhere to a delicate surface and may damage the object when it is removed. Once protected with one of the smooth papers, such objects may be wrapped in cotton batting for further protection before being placed in the packing container.

Mineral wool, a non-combustible material made of asbestos or gypsum, though less frequently used, is also entirely satisfactory for this purpose.

Pictures covered with glass. If glass must be left on pastels, drawings, prints, watercolours or other works on paper, it should be protected by affixing strips of masking tape to the surface in a criss-cross pattern or, better, in horizontal strips $\frac{1}{4}$ in. apart. The strips are applied to hold small fragments of glass together should any breakage occur in transit. Paper or cloth glued to the glass has proved unsatisfactory because many packers are careless in removing it with water. Moisture penetrating under the glass can cause serious and sometimes irreparable damage to a drawing or watercolour. The advantage of the masking tape is that it can be removed easily by merely pulling one end away from the surface to which it is attached, and it can be used over again. Fresh masking tape leaves no mark on a glass surface, nor does it dry out or come loose from the glass.

Glass measuring more than 24 x 30 in. should always be removed and packed separately in a compartment at the bottom or side of the container; or alternatively, the picture can be removed and packed separately, the glass being taped and packed within the picture frame. For travelling exhibitions it is always preferable to ship pictures without glass covering.

Condition of objects

Paintings and other highly valuable works of art in poor condition should not be subjected to the hazards of shipment. All works should be carefully examined prior to shipment and a record made of their condition. If possible, photographs should be taken for 'before and after' comparison should any question of damage arise. Such photographs are invaluable when a claim for insurance is necessary.

Marking cases

All shipping cases should be clearly marked in stencilled letters at least 2 in. high in black indelible ink to assure careful handling and indicate shipping destinations during a tour. Words such as *Fragile, Handle with Care*, should be painted on the outside of the box in bold letters. An international symbol for a work of art (e.g., an artist's palette) might be agreed upon to be stencilled on every case containing a valuable work of art. Shippers remark that the goblet, used to signify fragile materials such as glass or china, is now recognizable to all who handle packing cases. The symbol for a work of art would also in time become universally recognized and would ensure more than the customary caution in the handling of large boxes. Often language difficulties make the printed words useless, but until an international symbol is adopted, it is wise to print on the box in large letters *Works of Art*, or *Painting* or *Sculpture*, in whatever languages may be necessary.

A meeting of governmental experts from fifty-two Member States was held in Geneva in 1957 concerning the Unesco Agreement on the Importation of Educational, Scientific and Cultural Materials. The meeting decided that: 'Every possible facility is to be given to the importation of educational, scientific and cultural materials for showing at an approved public exhibition and for subsequent re-exportation. These facilities include exemption from customs duties and certain other charges and the granting of the necessary import licences. In addition, it is recommended that, both upon exportation and importation, the customs inspection should occur at the museum or place of exhibition, in the presence of a museum curator and his specialized staff.

'The 1957 meeting, noting that most exhibitions entitled to these facilities have been held under the sponsorship of the International Council of Museums, recommended that exhibitions certified by that organization should be granted the privileges of Article III. The International Council of Museums, with the approval of the 1957 meeting, has established a label for that purpose.'

The label, reproduced overleaf, calls attention to art shipments and ensures proper

care and, under Unesco's general programme for facilitating passage of educational and cultural materials across frontiers, it is designed to expedite and simplify customs procedures.

The screws or bolts which should be removed to open the case and saved for use in reshipment should be clearly so marked on the box, together with the indication *Open Here*. To facilitate better handling of material which should remain in one position, the box should also bear the message *This Side Up*. Sometimes exhibitors place 'fins' on all sides except the bottom, so that the case will remain stable only in the correct position (Plate 40).

Replacing packing materials

The general rule that loose packing material should be avoided in packing travelling exhibitions deserves to be stressed. If excelsior or cotton padding is absolutely necessary, as in the case of some sculptures or small fragile objects, the packing and unpacking instructions should indicate in bold painted letters on the inside of the packing case that these materials are to be saved for use in repacking, and that any damage to this padding during the tour must, at once, be reported to the circulating agency. The padding should then be replaced either by the agency or the exhibitor.

SPECIAL INSTRUCTIONS

Paintings

Oils, temperas, etc. The weight of the pictures to be placed in one packing case should not exceed the weight one man can handle. This stipulation is repeated because most damage to pictures occurs when cases are too heavy to be easily managed by those who must move them in and out of galleries, storage rooms, off-railway platforms or wagons. Sometimes several large pictures must be packed together to save costs of labour and materials in boxing; exhibitors should then be warned in advance that two or more men will be needed to move the boxes. The use of 'dollies' (flat platforms on casters) also enables one man to move large cases more easily and safely.

AGREEMENT ON THE IMPORTATION OF EDUCATIONAL, SCIENTIFIC
AND CULTURAL MATERIALS - UNESCO
ACCORD POUR L'IMPORTATION D'OBJETS DE CARACTÈRE ÉDUCATIF,
SCIENTIFIQUE OU CULTUREL - UNESCO



For customs use - Réserve à la douane	
CONTENTS VERIFIED AT EXHIBITION CENTRE VÉRIFIÉ AU CENTRE DE L'EXPOSITION	
PACKAGE (MARK AND NUMBER) COLIS (MARQUE ET NUMÉRO) :	
WIRED AND SEALED COLIS PLOMBÉ :	
DATE :	CUSTOMS OFFICE STAMP
	CACHET DU BUREAU

TITLE OF EXHIBITION	DÉNOMINATION DE L'EXPOSITION
---------------------	------------------------------

THIS PACKAGE TO BE PRODUCED AT CUSTOMS OFFICE AT ... CE COLIS DOIT ÊTRE PRÉSENTÉ AU SERVICE DES DOUANES DE	
I REQUEST THAT THIS PACKAGE BE CLEARED UNOPENED UNDER THE AGREEMENT FOR DELIVERY TO (3) JE SOUSSIGNÉ PRIE LES AUTORITÉS DE BIEN VOULOIR AUTORISER CONFORMÉMENT A L'ACCORD LE DÉDOUANEMENT DE CE COLIS ADRESSÉ A (3)	
SENDER : Mr EXPÉDITEUR : Mr	
SIGNATURE	DATE

(1) PORT OR PLACE OF EXPORTATION (2) PORT OR PLACE OF IMPORTATION (3) NAME OF EXHIBITION CENTRE	PORT OU BUREAU D'EXPORTATION PORT OU BUREAU D'IMPORTATION NOM DU CENTRE DE L'EXPOSITION
---	---

Label adopted by the International Council of Museums

The size of pictures included in travelling exhibitions should be limited to what one man can carry safely. If larger paintings are included, exhibitors should be informed in advance so that two men will be available for unpacking.

Paintings protected by glass present a special problem which we have dealt with above. Arrangements for their shipment should be made only with the consent of the owner. (For ocean voyages, it is not wise to remove glass from a canvas; the change in humidity may cause damage to the paint surface.) The substitution of heavy, rigid plastic for the breakable glass may reduce the risk of damage in transit.

Shadow boxes should be eliminated, if possible, from travelling exhibitions. Glass placed away from a backing, as it is in a shadow box, is more easily broken than glass backed against a rigid support. If shadow boxes must be included, they should be packed separately from other pictures in a special case.

Screw eyes should not be left on frames while in transit for they are apt to come loose and the pointed end may damage frames or pictures. Instead, small metal plates can be fastened tightly into picture frames with small screws (Fig. 19). There is little risk of such plates coming loose because the stress from the picture wire is on the opening in the metal plate, not on the screws.

Canvases mounted on stretchers, and panel paintings, should be firmly fixed in their frames before packing. Nails are not satisfactory for this purpose. The stretchers should be attached to the frames by means of metal plates or straps screwed into place (Fig. 19).

There are several satisfactory methods of packing paintings. The choice of method depends upon the material available, the cost and the risk involved.

Pads and separation sheets. The simplest method of packing pictures is one which has been accepted as standard for single shipments for some time. It is *not* recommended, however, for travelling exhibitions unless an exhibitor cannot arrange for packing in any other way. It is comparatively safe for single shipments and return from one museum to another. For successive shipments, however, the risk of damage caused by pads

breaking open after they have been used several times, or coming loose from the corners of the frames, is too great.

1. Group together pictures of equal size and place them face to face and back to back.
2. Tack, staple or fasten with adhesive, excelsior pads on to the corners of each frame. (Excelsior pads are made by taking strong, heavy wrapping paper, placing excelsior across the centre of the sheet and rolling the sheet of paper to enclose the excelsior. The open ends should be folded back and fastened together with gummed paper so that no excelsior will escape during transit.) These rolls act as cushions on the corners of the frames against shocks to the outer container (Fig. 20a).
3. Place between each picture separation sheets of corrugated board or heavy cardboard, cut to the dimensions of the inside of the packing case.
4. Place padded braces where needed to separate paintings of different sizes so that they will ride firmly in the box during transit (Plate 41).
5. Line up pictures based on pads set at one side of the case, filling in spaces left at the opposite side and at the top with 4 in. excelsior pads (Fig. 20b).

Packages. This method is suitable for packing small pictures, either unframed or framed, and also for panels or works on paper.

1. Wrap the picture in waxed or tissue paper.
2. Protect both the back and the front of the wrapped picture with corrugated or composition board of slightly larger dimensions, so that the corners of the picture will be fully protected. Fasten the boards in place with twine not pulled tight enough to come in contact with the picture, or with gummed paper strips, likewise avoiding contact with the tissue paper (Fig. 21).
3. Several small pictures can be packed together in this manner, each being wrapped first and protected as above with corrugated or composition board (or any rigid material which will not puncture or bend easily). The pictures are packed face to face and then bound together with heavy wrapping paper. Unframed pictures may also be packed together if the

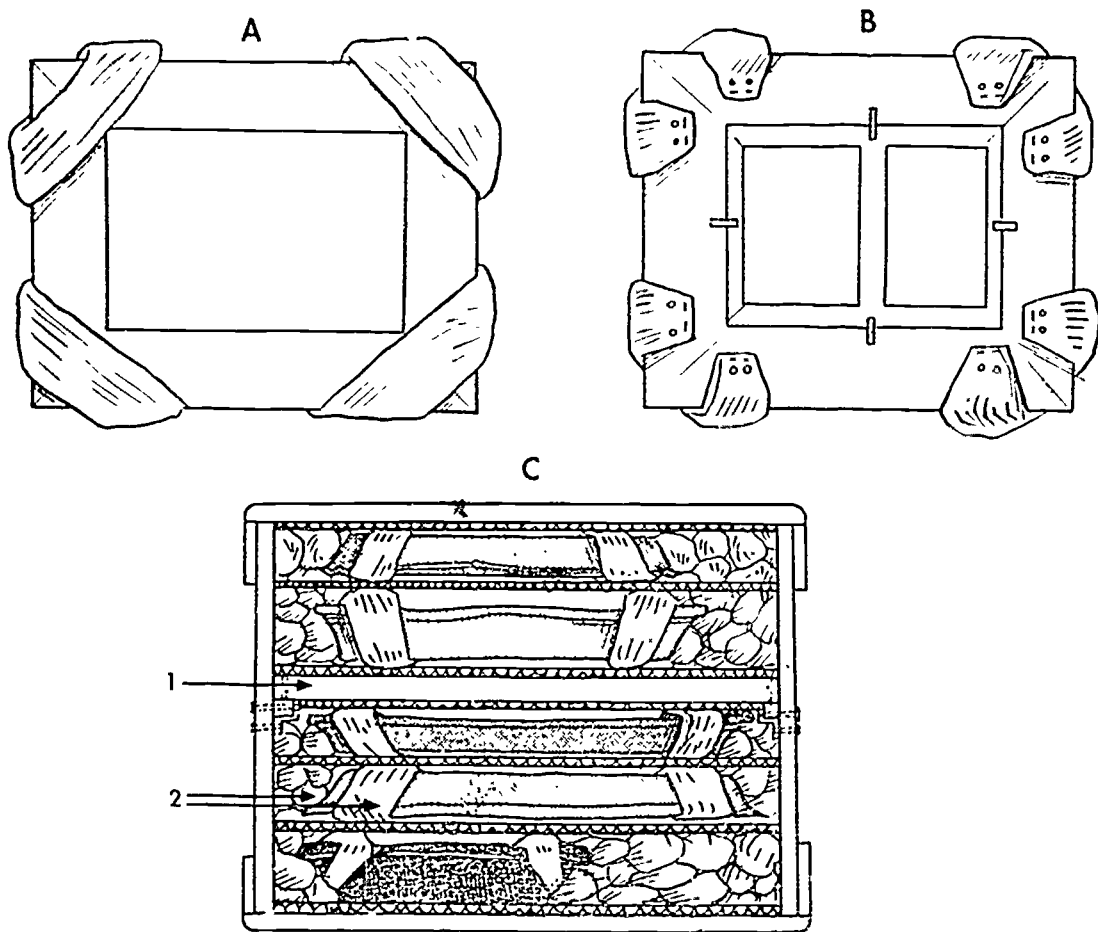

Fig. 20. Excelsior pads.

A. Front of picture, excelsior pads in place.

B. Back of picture, excelsior pads in place.

C. Box showing pictures packed with excelsior pads (2) and corrugated board separation sheets. Batten or brace (1).

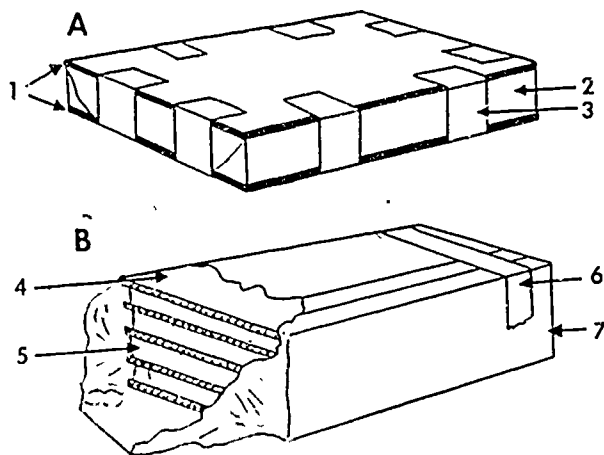

Fig. 21. Paintings wrapped for shipment.

- A. 1, heavy composition boards, 2, wrapping paper, 3, gummed tape. Heavy composition board prevents punctures in transit. The painting is wrapped first in tissue. The boards are held in place with tape or twine.
- B. 4, corrugated board, 5, tissue-wrapped pictures, 6, gummed tape, 7, wrapping paper. Framed or unframed pictures of the same size wrapped together for shipment. Each picture is wrapped first with tissue or waxed paper, then separated from the others with sheets of corrugated board. The packages are then 'floated' in excelsior in the packing case.

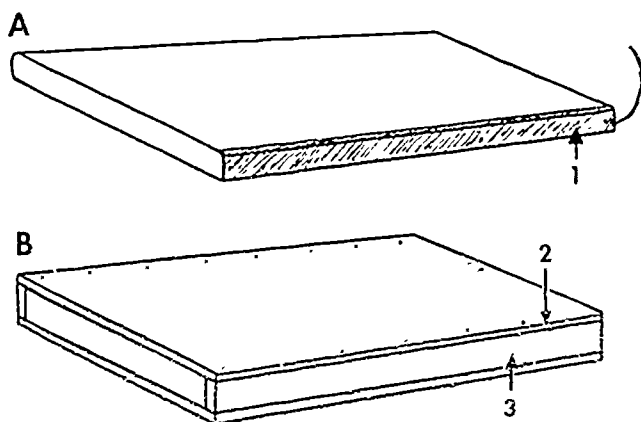

Fig. 22. Envelopes or inner cases.

- A. Cardboard envelope for framed picture. Canvas tape on cardboard (1).
- B. Plywood envelope for unframed pictures. The picture must be wrapped before placing in envelope. Plywood (2); $\frac{7}{8}$ inch lumber (3).

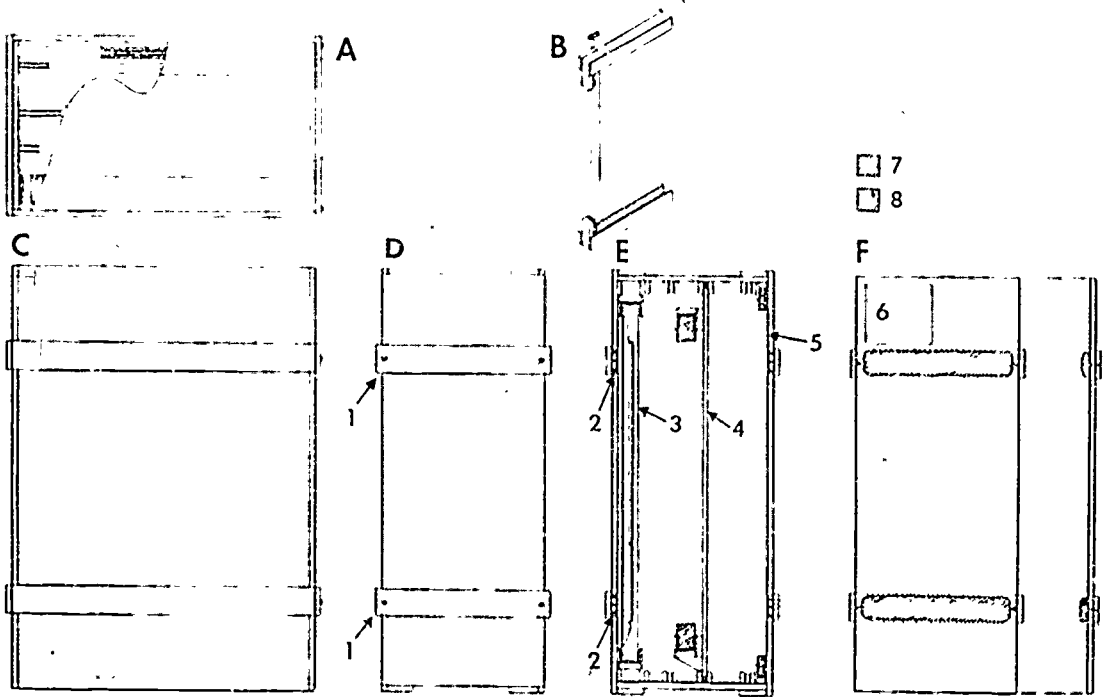

Fig. 23. Packing case with fitted grooves for paintings.

- A. Top exterior, cut away to show rack adjustment.
- B. Section of separate rack (half-scale).
- C. Side exterior.
- D. Front exterior (removable). Standard bolt and washers hardware (1).
- E. Interior with front removed. Standard metal plates (2). Packing shown in place (3). One rack shown in place (4). Waterproof paper covering entire inside of box (5).
- F. Inside of front panel. Instruction label (packing and unpacking) (6). (See Appendix I) Felt cushion (7). Foam rubber cushion (8).

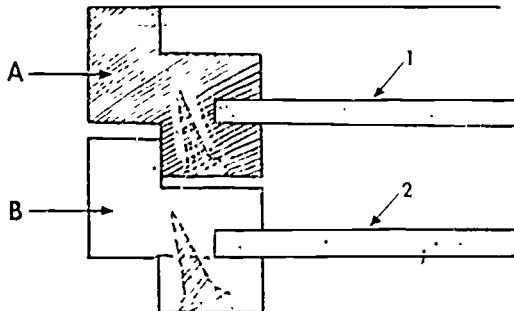

Fig. 24. Cross-section of interlocking frames.

- A. First frame.
- B. Second frame.
- 1, 2. Panel.

painted surfaces are smooth and in good condition.

Envelopes or inner cases. Used for small pictures, framed or unframed, but of approximately the same size. (If they differ greatly in size, the package method described above is preferable.)

1. A small box or 'envelope' of cardboard or composition board, cut to the dimensions of the picture, is constructed with one end left open, and the edges taped together with heavy canvas. The picture is first wrapped in tissue or waxed paper and then slipped into this envelope. Framed watercolours, drawings or prints do not need to be wrapped in tissue (Fig. 22).
2. The shipping box to contain the envelopes should be lined with thick pads of foam to prevent shocks sustained during travels being transmitted to the inner cases and thus to glass or paint surfaces. Envelopes can be held in place by a sheet of heavy composition board placed over the sponge pads so that the envelopes ride together on one cushioned surface, thus distributing their total weight. If different-sized envelopes are shipped in the same case, spaces at the sides and top should be filled in with thick excelsior pads, pieces of artificial sponge or several sheets of corrugated board taped together (Plate 42).

Cases with fitted grooves for pictures. This method has proved successful in the United States where it has been widely used over the past thirty years. It was arrived at after several related experiments to avoid sending any loose packing material with travelling exhibitions. The problem was to construct a shipping box which would fully protect the pictures from shock and yet enable exhibitors to remove and replace the pictures in their shipping containers with a minimum of effort. Furthermore, there was an evident need for a foolproof method—a way of packing which would permit no alterations in the box or packing method during a tour. If a case could be designed which would hold various pictures in only one way, inexperienced packers could not repack the box incorrectly.

The solution found was to construct cases with individual grooves so that each picture slides into its own compartment, clearly marked for it at the open end. This method is expensive because it involves a great deal of labour to fit the pictures carefully into their grooves. It has proved its worth, however, for pictures seem to be able to travel indefinitely in this manner without sustaining damage, and many steps in packing and handling are eliminated. It requires less well-trained labour since there is little risk in sliding pictures in and out of padded grooves.

1. Construct a wooden rack slightly larger than the framed picture (Fig. 23 and Plate 43). Line the rack with felt at the sides which will cover the edges of the frame. At the bottom, place a piece of thick plastic, cellulose or foam rubber so that the picture will be properly cushioned in transit.
2. Place the rack, padded with foam at all critical points of contact, into a groove made of boards nailed into the side of the packing case.
3. Add pads of foam across the lid of the case so that the frames will touch the pads here or at the bottom of the rack while in transit.
4. Fasten cover in place by sinking 3 inch bolts into holes provided in square metal plates, which are in turn screwed into the sides of the box with 4 inch screws (Plate 40).

The principle of this method is again to 'float' the picture in the packing cases so that wherever either picture or brace come in contact with the walls of the case, they are cushioned against shock with foam.

Trays

A similar arrangement has been worked out with a series of trays. The packing box is built to contain the largest picture, which is fitted with padding on all four sides. Smaller pictures are held in a series of trays or racks which are designed to rest in the box. The bed of each tray is padded with felt to avoid the necessity of wrapping (Plate 47).

Although the photograph does not show this, sheets of corrugated board are placed in

the tray and, once the picture is in place, over the back of the canvas, adding fuller protection should any object, such as a wood splinter, become detached during transit.

Framed watercolours, drawings, prints, photographs

In general, works in these media are treated in the same way as paintings and packed according to one of the methods described above, the choice being based upon the size of the picture and the cost involved.

1. All pictures covered with glass must be protected against breakage of glass in transit (see 'General Rules', p. 83). The best method, as already described, is to strip gummed tape which is not water-soluble at intervals of $\frac{1}{4}$ inch horizontally across the entire surface of glass.

Heavy wrapping paper or inexpensive cloth can be pasted on glass, if possible with a rubber-based adhesive, but this method is not recommended unless no other can be found. Paste or other water-soluble adhesives involve the risk of water running to the edge of the glass and penetrating beneath, causing serious damage to the picture surface. If their use is unavoidable, the paste should be applied leaving at least an inch of glass free of paste at the edges and the paper or cloth should be cut larger than the picture frame. This provides loose edges which can be grasped easily for pulling away from the glass. The glued portion must first be dampened with a wet cloth or sponge but exhibitors should be clearly warned never to *soak* the paper or allow water to run across the surface of the glass.

2. Pack the picture by one of the methods described under the heading of oils. For travelling exhibitions the most efficient method is to use envelopes or inner cases (Plate 42) which protect each individual picture.

If none of the methods described can be used, it is advisable to remove frames and glass before the exhibition is sent on tour. The pictures can be matted, the surfaces covered with heavy, clear plastic sheets (see mounting methods for watercolours, Fig. 7,

and Plates 36). They can then be shipped in inner cases, wrapped packages or 'solander' boxes. The latter are the stiff-sided boxes in which standard-sized matted prints are generally stored. The cover is hinged into place and drops over all four sides of the container. Solander boxes should be wrapped in paper before being placed in packing cases.

Oriental scroll watercolours should be rolled in tissue or waxed paper. Traditionally such rolls are kept in squares of fine silk in which they are placed diagonally and then rolled before being placed in metal tubes or wooden boxes. Metal tubes are, of course, a modern device. If scrolls are to remain packed for any length of time, airtight enclosure should be avoided.

Pastels

1. Do not remove glass or frame from pastels.
2. Protect the picture by affixing strips of gummed tape to the glass. Follow packing instructions under 'Oils' above for pictures covered with glass.
3. As pastels are particularly subject to damage in transit because the surface is so delicate, they are generally eliminated from travelling exhibitions.

Miniatures: ivories, woods, etc.

1. Do not remove from frame or mount.
2. Cover with tissue, then wrap in cotton.
3. Double box, first in cardboard container, then in outer wooden case. Use generous amounts of dry excelsior padding between inner and outer boxes to absorb shock.

Outer packing cases for all pictures should be constructed of strong matched lumber according to specifications given under 'General Rules'. All boxes should be lined with waterproof paper.

Small fragile objects

This classification includes ceramics, terracotta, glass, ivory, jewellery and small sculp-

tures of wood, metal or stone (Plates 44 a to e).

Protect the surfaces:

1. In preparation for packing, completely cover the surface of the delicate object with tissue, muslin or cheesecloth.
2. Wrap any projecting part such as a handle, arm, etc., carefully and independently of the body of the piece so that it is protected from shock, then wrap the entire object so that the projecting part becomes an integral part of the whole. Tissue or shredded waxed paper are acceptable materials for wrapping projecting parts.

Protect the entire object:

1. Place wrapped objects in small cardboard boxes. Surround object with sufficient tissue, cotton, or shredded paper so that no part of an object is without shock-absorbent support.
2. When placed in packing boxes, the inner boxes of cardboard should also be 'floated' in packing material such as excelsior, but packed firmly enough so that they cannot shift position in transit.

Small non-fragile objects

Objects in this class include small sculptures in marble, stone or bronze, silverware, coins, gems, etc. (Plates 44 a to e).

Packing:

1. Treat such works as if they were small fragile objects. In general, however, less surface protection will be required. The same amount of 'floating' material will be needed to prevent shock within the shipping container. Heavy pieces should be packed in plywood, rather than cardboard inner boxes (Plate 45). Certain objects normally classed as non-fragile have to be packed as fragile objects if they have been restored or if their surface conditions have deteriorated or there is any structural weakness.
2. Objects in this classification can be packed in separate cardboard or plywood containers or in compartments constructed inside the packing case. Each compartment is built to fit the individual

object, then filled with excelsior or lined with plastic foam or like padding sufficiently thick to cushion the object against shock (Plate 39 e). Plate 46 shows a combination of these methods. The interior boxes are lined with cloth-covered artificial sponge or foam fitted to the objects; the boxes are fixed in excelsior within the shipping container. Exhibitors have also recommended the use of bed ticking (heavy canvas) to line packing cases containing such objects. The canvas is nailed over excelsior padding to line the compartments inside the case. Instead of wrapping individual objects, small drawstring bags of quilted cotton-filled cloth are made for each object. This arrangement is useful for travelling exhibitions because it eliminates loose packing material which may not be repacked with objects each time they are shipped. Marked individual containers are always safer; the packer learns to look for a particular compartment or case for each object before packing it.

Works on paper

Objects in this category include prints, drawings, posters, manuscripts, pages from books, photographs, etc.

Surface protection:

1. Place such works in window mats with clear cellulose acetate or plastic covers if they are to be shipped unframed (see 'Watercolours, drawings, prints...', p. 66).
2. Works of art not so protected can be shipped with glassine or pure mulberry paper covering the decorated surface. Sized paper should not be used and printed matter or poor-quality papers should not be placed in direct contact with works in this group. This method is not suitable for travelling exhibitions because the surface of the work is not fully protected at all times, the work will be subject to continued handling, and there is risk of successive exhibitors losing protective papers and mats becoming soiled and damaged by constant handling. It is mentioned here only for those who must avoid the added expense

of encasing works in transparent covers and who are willing to risk this method for several shipments. Valuable works on paper should never be sent on tour unless they can be adequately protected.

Outer protection:

1. Solander boxes—made for storage of standard-size mats—are recommended as the best type of inner packing box, especially when works are matted without a protective plastic sheet covering the surface. (If exhibitors adopted the use of standard-size mats and solander boxes for storage of prints and drawings, both shipping and display would be greatly facilitated. Museums could stock standard-size frames so that unframed works could be easily framed on arrival for exhibition.)
2. Six to twelve items may be wrapped together with corrugated board, cut to size, placed at top and bottom of the group to prevent bending. Use strong wrapping paper to bind the group together.
3. Sometimes these works are covered with glass, backed with heavy cardboard and sealed into place with adhesive tape around the edges. Works mounted in this manner may be slipped into narrow cardboard envelopes, or wrapped together (not more than six at a time) with corrugated board sheets between each item. If bound in this manner, it is not usually necessary to tape the glasses before packing (Fig. 27).
4. Posters can be rolled and shipped in a cardboard or lightweight metal tube, or wooden box. They should be protected with sheets of tissue between each poster.
5. The outer box should be constructed of wood, either plywood or $\frac{7}{8}$ inch boards, depending on the weight of the items. It should be lined with waterproof paper, sealed into place. Foam or excelsior-filled pads should be used to line outer cases to protect the solander boxes or wrapped packages from shock in transit.

Books

Valuable bindings:

1. Books for which individual cover boxes are available should be placed in their

boxes, then wrapped with brown paper.

2. Books without cover boxes should be wrapped in tissue, then in corrugated board. Inlaid or jewelled bindings should be treated as small fragiles.
3. For travelling exhibitions of valuable bindings, exhibitors may provide glass or plastic cases. For transit the bindings and cases should always be packed separately.

Other:

1. Books of the same size may be wrapped together in tissue, then in heavy brown paper, and finally in corrugated cardboard. Books wrapped in paper only must not be tied tightly with twine, which will mar the bindings; gummed tape is preferable for sealing wrapped books.
2. Double packing ensures greater protection for all bindings and helps to prevent shifting in the outer packing boxes. The packages of books should be 'floated' in excelsior to prevent damage in transit and then outer boxes should be waterproofed.

Textiles

The fragility of textiles is not apparent on casual examination; accordingly, damage from creasing is a constant hazard. The entire thread structure may be endangered by improper folding.

Surface protection:

1. Clean hands are essential when working with textiles. It has been found practical to send along with a textile exhibition at least two pairs of white cotton gloves, requesting those who will handle the textiles to wear them.

Fabric must be so wrapped that dust is excluded. Lay pieces of tissue on the surface of the cloth and roll the textile on to a drum, cardboard tube or round wooden pole. This method prevents creasing.

2. If textiles must be folded to fit a package or container (costumes, bags, etc.) several layers of tissue should be placed in the folds to reduce creasing.

Outer protection. For textiles mounted in frames, or fixed on stretcher, or on wall panels:

1. Use corrugated or composition board, cut to size, at front and back of each frame to stiffen the backing cloth to which the textile is attached in order to reduce vibration. Several framed textiles of the same size can be wrapped together in a single package. If the textile is framed with glass, treat as a picture, stripping the glass with masking tape at intervals of $\frac{1}{4}$ inch. If it is matted only, treat as a print or drawing, wrapping several together in a package.

If textiles are mounted on frames, uncovered, wrap the surface of the textile in tissue, affixing the paper to the backing board with masking tape before packing the frames in the outer case. Be careful not to allow the masking tape to touch the surface of the textile itself.

2. Place wrapped packages in wooden boxes large enough to allow for resilient padding between inner and outer containers. Cases should be lined with waterproof paper.

For unmounted textiles:

1. After placing tissue in the folds, wrap the textile in tissue, then in brown paper (or, as above, place the tissue on the surface and roll the textile on to a round support). Wrap the exposed outer surface, first in tissue, then in brown paper.
2. If folded flat, pack with tissue in a cardboard carton just tight enough to prevent movement in transit. The packed cartons are then placed in wooden shipping boxes.
3. Wrapped packages or cardboard boxes should be cushioned with excelsior pads between each package when placed in the outer packing case.

Moths and other insects should be guarded against at all times. If textiles show evidence of insect attack, they should be fumigated before packing.

Large objects

This classification includes heavy sculpture, furniture, woodwork, etc. The danger in moving and packing any valuable object is increased by unusual size or weight. Each large object is a special problem in itself,

requiring extra care in handling and packing. Exhibitors should be so warned prior to arrival of an exhibition so that sufficient staff is in attendance to assist in unpacking and handling.

Sculpture. Each piece of sculpture must be carefully studied and the method of packing chosen will depend upon the medium, weight, fragility and the way the object is put together. Braces should not be attached, for instance, if there is danger of placing stress on a joint. Three methods have been worked out for safe shipment:

1. The first step is to protect the surface of the object. Wrap it in flannel or other soft cloth. The simplest method, used for non-fragile pieces which are not heavy, is to place the wrapped sculpture in a bedding of excelsior so that it will 'float' in its container. Sufficient excelsior must be used to prevent any possibility of the sculpture coming in contact with the walls of the packing case. It is advisable to place pads at all projecting points, and to wrap pads at points of stress before placing the object in excelsior. For further protection use double boxing, placing excelsior again between inner and outer containers. Curators or conservators must take the decisions with regard to boxing, and responsibility for handling and packing this type of material should never be delegated to packers alone.
2. If there is any question about the condition of a piece of sculpture, or if it is very fragile or extremely heavy, it should be fitted with padded braces to reduce shock in transit (Plates 47 a, b). If it is not heavy, but is fragile, it is wise to use double boxing. Braces should be padded with firmly attached heavy excelsior pads, or better, with heavy felt or foam rubber pads covered with muslin or some other inexpensive cloth. This prevents the foam rubber from tearing apart, and eliminates any risk of staining the polished metal surface.
3. If the piece is large and heavy, a special case should be constructed. Again the surface is usually protected by a cloth wrapping, and padded braces should be fitted to hold the sculpture in place in the

packing container (Plates 48a to c). The container may be built in pyramid form to ensure that it will be placed in the correct position during transit, or fins may be fitted on the outside of the case for the same purpose. The fins are large bars of wood, rounded at the ends, fixed at the centre of each side of the box and on the top. The box will not ride steadily unless it is correctly placed on its flat base. It should, of course, be marked *Top*, *Bottom*, *This Side Up*, *Fragile*, etc. A rectangular box is more convenient for shippers, although in certain instances a pyramid may be necessary, for example, when a sculpture must always be held in a certain position.

Furniture :

1. For small tables, benches, chairs, desks and similar items which have been weakened by age, hard wear, dry rot or insects, it is essential to 'float' the object in its container. As for sculpture, large heavy pieces of furniture must be braced in their shipping containers to prevent damage to lightly attached or weakened parts.
2. Braces must be placed so as to bear the main weight of the piece without endangering its weak parts or decorative elements. Both the piece of furniture and the braces should be heavily padded and the wider the brace, the less shock will be transmitted directly to any one part.
3. As a general rule, objects for which bracing is required should be double-boxed. In this way the 'floatation' material packed between inner and outer containers will reduce bracing shock to a minimum.
4. The fabric covering on upholstery is frequently old and worn; it must be covered with muslin or wrapping paper. Arms and legs of chairs should be padded with packing cotton, fabric-covered foam rubber, felt or shredded paper. Kraft-type wrapping paper should not be used, especially on curved parts, for when creased it is sharp enough to scratch varnish.

Architectural models, stage settings, etc. No surface protection should be provided for models. Many parts are extremely fragile,

and it is usually advisable to allow the model to ride without any packing material touching its surface. It should, however, be protected from shock by thick pieces of foam or large excelsior pads placed around the base, against the sides of the packing box and beneath the model. Models are often fitted into foam-lined grooves, leaving air space above and below.

Unless models are very sturdily constructed, they do not travel well. They should be made of wood, not cardboard, and should be in good condition before shipment. Usually only expert model-makers can make repairs, and these take considerable time and are costly.

Panels

The least expensive method of packing panels is to place them face to face and back to back with sheets of corrugated board between, then wrap in heavy paper and seal. This method can be used successfully provided there are no projecting items mounted on the panels. Panels containing photographs and labels only can be packed in this manner, but there should be a frame which projects slightly all around the edge of the panel to protect the surface of the mounts from being rubbed in transit. Foam rubber or other synthetic foam or excelsior pads should be placed between the wrapped panels and the walls of the packing case to cushion the edges in transit (Plate 43).

The slotted box offers a better method of shipping panels whereby they are slipped into felt or rubber-lined grooves built on the sides of the packing case. Enough space is left between grooves to ensure that no object mounted on a panel will touch another object or panel during transit.

If fragile items are displayed on panels, it is wise to remove these and pack them separately in another container for shipment.

As an aid to packing, frames of panels are sometimes moulded so as to nest one within the other, in this way protecting shallow objects fixed to the surface of the panels and forming a solid mass of six to eight framed panels which cannot shift (Fig. 24). The group of panels is then slipped as a single unit into a packing case. This method elimi-

nates the need for slots and grooves for individual panels and requires only the simplest kind of padding in the cases. Excelsior or foam pads cushion the group of panels in transit.

Museum exhibitions other than art

The general instructions for packing cases, padding and wrapping apply to museum objects of all kinds to be prepared for repeated unpacking and repacking and shipment. Fragile specimens and objects of all kinds should be treated like comparable items of art. Large natural history specimens may be packed in the same way as large sculptures, particular attention being

given to appropriate measures of protection for fur and other surfaces. (See sections on 'Textiles' and 'Large Objects', p. 96-98 for some suggestions.) Glass used in scientific instruments must also be properly protected. Heavy items and machinery should be packed according to current industrial and commercial methods. Packing instructions are not, of course, a substitute for experience in the actual handling and protection of objects. However, care in studying instructions and an effort to understand the nature of a given object and the dangers to which transport will expose it, and ingenuity in finding methods to guard against these dangers can lead to the discovery of sound packing techniques, and these can be perfected by experience.

TRANSPORTATION

SHIPMENTS BY TRUCK

Some museums and circulating agencies have their own truck or lorry for the transport of their travelling exhibitions, for example in the United Kingdom, the Victoria and Albert Museum and the Arts Council. This system is practical, especially in countries where points of exhibition are apt to be no great distance apart, and it has the advantage that staff members can accompany shipments so that packing for transit is reduced to a minimum (Plates 44 a to e).

Generally speaking, however, museums do not find it economically sound to operate their own truck unless this offers a far more efficient means of transport than any other system available or unless the volume of loans to be transported is particularly heavy and justifies the cost of maintenance. In addition to the original cost of equipment, upkeep, allowance for depreciation, insurance, the operator's and other staff salaries must be taken into account in comparing the cost with other means of transport. In order to fix transport rates to be charged to borrowing institutions, accurate records must be kept of all expenses incurred, including man-hour charges. Sometimes, of course, transport costs are borne by the museum which offers the lending service.

More often, museums employ trucking firms whose business is the transport of all types of objects. In shipment by truck it is usually necessary to box works of art, fragile historical and scientific specimens, and apparatus and machinery designed for exhibitions with the same care as for shipment by rail. Truck operators are usually co-

operative in carrying out instructions for the protection of the exhibition material, but they cannot be expected to exercise the same care as well-trained museum staff. They must be given specific rules to make certain that safety precautions are taken, and if the exhibition is to be shipped to more than one destination, full protection must be provided for the objects by the organizing institution and the packing instructions which apply to shipment by rail or boat should be followed. The only exception to this rule is the case where a museum can spare one or more trained staff to accompany the exhibition and to supervise all handling operations. Under these circumstances, provided the truck carries exhibition material only, crates may provide sufficient protection and it may not be necessary to double-box fragile items or to enclose paintings or sculptures in heavy wooden cases.

Weight is an important factor also, since loading limits must be observed, and for very heavy cases additional workers will be needed. Consideration should also be given to convenience of handling and the physical safety of the workers; size and weight per unit must be limited and hand grips should be provided wherever possible. Such warnings as *This Side Up, Fragile, Handle with Care*, etc., should be clearly marked and boxes which must travel in one position should not only be so marked but constructed so that the correct position is assured.

Some trucking firms pack an entire shipment in a single large unit, which can be transferred for further shipment by rail or boat, then delivered to the final destination by truck. The advantage of this method is that the large single units are moved by

machine and there is little risk of their being roughly handled or dropped. All the museums on the circuit must, of course, have space enough to receive a unit of this size so that unpacking can be done on the premises; inquiries concerning this should be made in advance.

Because it is not general practice to use trucks for shipping exhibitions intended to cover a lengthy circuit, detailed instructions for handling unboxed museum objects have not been given here. However, museum practice should be followed for the shipment of unboxed material by truck, preferably under the supervision of a member of the museum staff (for general handling instructions, see Appendix II). The Victoria and Albert Museum in the United Kingdom, and the American Federation of Arts in the United States of America, have great experience in such matters and might be consulted for advice.

SHIPMENTS BY RAIL

In many countries there are two methods of shipment by rail: by express or fast freight agencies which have members of their own staff stationed at all leading and many minor points of embarkation; and by ordinary rail freight which is carried by the railway and handled by its staff only. If the shipment is made by rail freight, museums must normally arrange to pick it up at the railway's freight office and transport it by truck to the destination. Express companies, however, often provide trucking services from rail station to point of destination in addition to handling the shipment by rail.

It is generally agreed that far greater risks are involved in the handling of rail freight shipments than shipments by express, and that although rail freight is slower and the rates much lower, express is preferable for shipping works of art or other fragile or valuable materials. Furthermore, speed is an advantage for travelling exhibitions which must meet specific dates.

On the North American continent, the Railway Express Company offers a Fine Arts Bill of Lading which implies a measure of special handling for the consignment. Goods thus consigned are shipped under the com-

pany's Uniform Special Contract for the transportation of paintings, carvings, glassware, sculpture, etc., of a value over \$550. For shipments of ten or more cases on special contract the company usually provides direct transit from museum door to freight car, thereby eliminating unnecessary handling at intermediate collection depots. Arrangements for this service should be made in advance with the local express office.

The Railway Express Agency's basic shipping rate (during 1950) included a minimum insurance of \$50 per box or 50 cents per pound for shipments weighing more than 100 pounds, without additional charge. Above this minimum, charges for additional coverage were computed according to a sliding scale on a weight-plus-valuation basis. If the exhibition was already insured in transit as well as on exhibition, the use of the Uniform Special Contract involved paying further insurance based on a valuation of \$550 per case. This was not warranted except for extremely valuable material when it was considered that the special handling guaranteed by the Railway Express Contract might minimize damages in transit. In recent years it has become standard practice in the United States for art museums to declare the \$550 valuation per case for all shipments. Many art museums demand declaration in excess of this amount for all loans made by them; some also make other protective services offered by the carrier obligatory.

The Railway Express Agency operates services within the United States and to and from Alaska, Canada, and Hawaii, and a similar company offers the same services in Canada. Elsewhere, shipping services, rules and documents vary considerably and museums in each country will naturally use the transport services available to them according to their requirements. International shipment, however, should usually be planned with the advice of the museum authorities in the countries to which the shipment is to be sent. The American Express Company, which has offices in some 150 cities in thirty-three countries, offers international service and provides information about rail service and rules in many countries; it will also act as an agent for the shipper, co-

ordinating arrangements with the various carriers which will transport the exhibition to its ultimate destination. Most countries have one or more packing and shipping organizations experienced in international shipping. Museums should investigate all the services available and make their decision according to convenience, rates and local conditions. Consulates are usually able to provide additional information.

OCEAN TRAN. PORT

Since shipment by port involves greater hazards than shipment by rail, cases must be strongly constructed to withstand repeated handling at points of embarkation and arrival, the pressures to which they are subject during loading from dock to ship, and the rolling and pitching of the ship when storms are encountered. The interior packing must hold the contents firmly in place and unless proper precautions are taken to eliminate salt air and resist temperature changes, the contents may suffer serious damage. *Safe shipment overseas requires very special attention to packing procedures. The circulating agency should also make special arrangements for customs examination at the place of destination; boxes will otherwise be opened on the docks and repacked for delivery to the museum with less care than is customary in a museum.*

Import and export regulations frequently tend to obstruct rather than encourage the movement of cultural material from one country to another. At present difficulties arise not only from tariff barriers and restrictive interpretations of these laws but also from a general lack of information about customs regulations on the part of institutions and their agents. Under the leadership of Unesco, some progress is being made toward breaking down trade barriers and fostering the exchange of educational, scientific and cultural materials. In November 1948 the Agreement for Facilitating the International Circulation of Visual and Auditory Materials of an Educational, Scientific and Cultural Character, designed to remove duties, quotas, licences and other obstacles to exchange, was introduced at the General Conference and is open for acceptance by all Member States of Unesco or the United

Nations. A second Agreement on the Importation of Educational, Scientific and Cultural Materials¹ has been ratified by a considerable number of Member States. This agreement will grant duty-free entry to a wide range of commodities including works of art, visual and auditory materials crossing their borders. (For the present rules governing import and export regulations in different countries, see the index by countries provided in *Trade Barriers to Knowledge*, Unesco, Paris, 1951, revised 1955.)

Institutions shipping exhibitions for international tours must be familiar with import and export regulations in order to issue proper instructions to their agents. Such documents as consular invoices, certificates of originality, proofs of antiquity and other essentials are required by many countries for certain kinds of shipment. The circulating agency should include in shipping instructions a list of the documents required by foreign countries of exit and entry well in advance of shipping dates so that the exhibitor will have time to obtain import and export licences if required. Shipments will not be accepted at certain ports if contents are packed with hay or straw instead of excelsior or shredded paper (see 'General Handling Rules', Appendix II).

Customs brokers or forwarding agents are usually familiar with the procedures necessary for clearing imports and exports through customs, and generally speaking the charge for their service is reasonable, if account is taken of the time it would take for importers and exporters to clear shipments through customs without professional help. These agents can work much more efficiently, however, if they receive specific instructions from importers as to how they wish to have their shipments handled and are authorized to sign bills of lading, affidavits, bonds and other customs documents. By issuing proper instructions to foreign and domestic agents, museums also facilitate the work of the customs officials.

Documents required for ocean voyages usually include some or all of the following:

1. Copies of these Agreements may be obtained from the United Nations' Headquarters in New York, or from Unesco, Paris.

Bills of lading. Showing names and addresses of shippers and consignees, marks and/or numbers of cases being shipped, weights, size and general description of contents. Unless the carrier requires a full value declaration, a nominal value, or the value for which no additional charge is made (usually \$500), is shown on the bill of lading.

Export licence. Declarations or licences as required by various countries for exports.

Dock receipt. For carrier employed to deliver shipment to pier,

Delivery order. For carrier employed to collect shipment from pier.

Import licences. As required by countries of destination.

Other documents. Consular or commercial invoices listing each item with its value and showing names and addresses of consignors and consignees, certificates of originality, authenticity, antiquity, etc., as required by countries of destination.

The shipper or circulating agency should always request the latest regulations from the proper consulate or other informed authority. Shipments sent without proper papers often wait months for clearance at docks or other storage houses with the consequent risks of handling and exposure.

Many of the large steamships are equipped with strong-rooms for storing valuable merchandise; this special storage should always be requested for shipments of works of art. Though certain steamship companies require a declaration of a value over \$500, and charge an increased freight rate for this preferred placement, this is not general practice.

AIR TRANSPORT

The most rapid method of transporting works of art often requires the least effort. It is reputed to be smoother than any surface shipping and therefore requires no additional precautions. Because the shipments are handled a number of times after arrival at points of destination, however, it is wise to pack materials according to the standards set for rail shipment. If it is known that a cargo will be carried directly from airport to museum by truck, lighter packing

cases may be used, built of plywood or rigid tough composition board reinforced by heavy lumber cleats. Cardboard or corrugated board cartons are not safe because there is considerable risk of puncture during loading and unloading operations. In the new pressurized cabins, boxes are subject to little or no change of humidity or air pressure and therefore travel in relative safety while in the air. For long hauls overland, since air transport involves less handling, the risk of damage by shock is reduced.

For individual objects of great value and fragility and of moderate weight, air transport, which is quicker and safer, is preferred by many museums. Insurance rates are often lower, and some art museums in the United States insist on shipment by air express or by air freight for all loans made even to other museums in the country.

Exhibitors should check on whether delivery service is provided by the airline; if not, arrangements should be made in advance with a private trucking company to collect the shipment at the airport and deliver it.

The principal disadvantage of air shipment is that exhibitions are exposed to risk of total loss should an air accident occur, whereas with surface shipment some salvage is usually effected.

Although little has yet been done to develop new containers for the air transport of works of art, light strong containers made of metal, fibre or plastic and scientifically designed for this purpose will eventually be produced with built-in shock absorption so that double-boxing would be necessary only for the most fragile, delicate and valuable items. New methods will also be required for the protection of objects against rapidly changing relative humidity. Boxes removed from pressurized cabins may be exposed to extreme changes in temperature and humidity and means must be found of slowing down the penetration of heat and humidity to the packed object. Precise control may eventually be achieved by the use of chemical compounds to produce the desired conditions, and, in such cases, exhibits which are not normally made airtight will be carefully sealed.

Silica gel, a chemical which absorbs and holds moisture, is used by many companies

which export materials overseas; it dehydrates the air inside moisture-proof or reasonably moisture-proof containers and thus maintains air humidity below the point at which corrosive action or mildew can take place. The application of such methods to shipments of works of art and other valuable and fragile museum objects will require further testing.

New materials for the prevention of rust, corrosion and mildew have recently been made available and may prove to be of great value for ocean and air transport. Transparent plastic sheets such as those made from polyvinyl chloride are impervious to water and moisture vapour which can penetrate ordinary waterproof papers. Liquid

plastic sprays (copolymers of vinyl chloride and vinyl acetate and copolymers of vinylidene chloride and acrylonitrile) have been employed to seal containers for transit or for storage ("cocooning") for scientific equipment, motors, etc., and might also be used for works of art.

Most commercial airlines issue booklets containing rates, documentary requirements, rules and regulations applicable for shipments between international airports. As documentary requirements for various countries are subject to change, it is necessary to check all such information with the proper consular offices, the appropriate national government department or the Office of International Trade.

INSURANCE

The preparation of travelling exhibitions, whether of original works of art, reproductions or other materials, involves a number of risks which can usually be covered by insurance. The principal risk of damage to art objects is in moving them. As one curator puts it, 'Insurance policies are taken out to cover every stage in the operations, an indication that accidents may occur from the moment a picture is taken down'. For this reason, most insurance policies for exhibitions on tour cover all items against all risks from 'wall to wall' (an object is thus insured from the moment it leaves its owner until it is returned). Arrangements for insurance depend of course upon the nature of the material to be insured, the reputation of the institution or museum and the extent of responsibility it assumes. The method of shipment and, finally, the underwriters.

Consequently, no set rules or other instructions can be given. Certain facts relating to all shipments may be mentioned, however, to assist those who must take the necessary decisions. Although procedures differ slightly from country to country, the basic provisions for protection are the same everywhere. Specific clauses applying to one type of material and to special conditions can be added.

The description of insurance provisions given below is based on policies commonly written for fine arts insurance in European countries and in the United States. Fine arts insurance is taken as the example, as, generally speaking, it is the most complicated form of insurance coverage owing to the high values involved, measured in irredeemability as well as money, and the fra-

gility of the objects which it must cover (see Appendix III).

TYPE OF POLICY

Most museums carry insurance covering property on loan to them in the same way as they insure their own collections against loss or damage by theft, vandalism, carelessness in handling, accidents, etc., with certain exceptions listed by the insurers. When borrowing an object for tour, it is advisable to inquire from the owner what coverage is to be carried, the valuations listed and the method of shipping to be employed. If an owner prefers to extend his own policy to cover the object during the tour, the borrowing museum usually pays the premium for the period of the loan. For a large collection, however, it is preferable to include all items under one 'all-risk' policy; values are then listed and reports of damages made monthly, and at the same time items returned to owners may be cancelled from the policy. Some policies automatically cover all shipments involving the responsibility of the museum whether or not the insurance company has been notified. This type of policy, called a 'Fine Arts Floater', is written under the so-called inland marine policy form which was devised to provide coverage for transport risks, not principally water-borne; it has been expanded over the years to cover numerous types of exposure. Policies insuring a collection during ocean transit are usually drawn up separately, or coverage is added to the 'floater' policy in an endorsement made at the time of shipment by boat.

Exhibitors of travelling exhibitions usually have little to do with insurance arrangements, since it is more efficient for the sponsoring institution or circulating agency to handle all arrangements and make all claims rather than divide these responsibilities. The rental fee paid by each exhibitor covers his share in the cost of the insurance, but his responsibility to the circulating institution and ultimately to the original lenders is none the less real. The acceptance of the exhibition for showing in his galleries carries with it an obligation to both sponsoring institution and lenders to exercise the greatest possible care in handling the material on loan. Because this responsibility is not always automatically assumed, clauses protecting the sponsoring institution or circulating agency are often written into exhibition contracts, to the effect that 'exhibitors will be held responsible for losses or damages due to carelessness'.

A similar responsibility must be assumed by organizations which borrow works of art for circulation; They must guarantee the lender adequate protection for his loan, by ensuring safe packing and issuing instructions to those who will handle the objects; they must request that exhibitions be guarded at all times; that no repairs be made by exhibitors; that all damages or losses are reported at once. A reduction in insurance premiums for travelling exhibitions is sometimes granted if these measures are taken and few losses or damages occur. Conversely, insurance may be cancelled if the institution circulating the collection is guilty of misrepresentation, negligence or carelessness, or if the borrowing institution fails to carry out instructions issued to exhibitors.

BAILEE' LIABILITY INSURANCE

If an owner maintains his own insurance on a loan, the museum organizing the exhibition often takes out 'bailee' liability insurance to cover itself should the owner's insurers make a claim against it. This type of coverage may be added to a 'floater' policy in the form of an annual endorsement; single claims are usually limited to a specified maximum, for example, by a clause stating that the company is 'not liable for more than \$100,000 for any one casualty'.

ESTABLISHING VALUES AND SETTLEMENTS

When an object is borrowed for a travelling exhibition, the owner is usually asked to sign a form of agreement stating the type of coverage provided by his insurance policy and giving his valuation in case of total loss. The insurance company holds the museum responsible for the fairness of such valuations. Since it is extremely difficult to determine the market value of a work of art except by sale or auction, the means of arriving at the figure for insurance should first be agreed upon by the insurers, the borrowing institution and the lender. Such agreements avoid difficulty in settling claims should loss or damage occur. If disagreements take place, settlement is usually made by calling for the decision of a third party, usually a recognized expert in the marketing of works of art.

Similar difficulties may arise in settling the cost of repairs or depreciation to an object damaged on tour. Again, the insurers depend largely upon the museum staff to judge the fairness of the owner's claim. The cost of minor repairs, sometimes made by a museum staff, are often assumed by the borrowing institution, so that 'nuisance' claims need not be reported to insurers. If no claims of this kind are made, lower premium rates are often granted. Extreme caution must, however, be exercised in making repairs, and no repairs whatsoever should be undertaken without the written permission of the lender. Any repair involving technical skill should be undertaken only by experienced technicians. In fact, most standard 'floater' policies specifically state: 'Does not insure against loss or damage occasioned by: wear and tear, gradual deterioration, moths, vermin, inherent vice or damage sustained due to and resulting from any repairing, restoration or retouching process'.

DECLARED VALUATIONS

In general practice, a collection is fully insured during a tour by a 'floater' policy. During transit, the exhibitor must declare a nominal valuation on each case and the carrier is then liable up to this amount. The

declared valuation is usually carried free of charge. Higher valuations are sometimes permitted with the result that greater care is taken in handling.

CARRIER INSURANCE

The carrier assumes a certain amount of responsibility for the safety of exhibitions in transit. His own insurance rarely covers the full value of the exhibition and is usually limited to the declared value of each case, the bill of lading or the amount of coverage under the conditions laid down by his company, which usually limit his liability to a fraction of the value of works of art, even though additional charges may have been paid for a higher valuation.

Consequently, the owner, or the organization responsible for the safety of the objects on tour, rarely relies upon the carrier's insurance to cover the shipment in transit. To recover a loss in full, exhibitors must make specific arrangements with the carrier at the time shipment is made to provide full insurance during transit.

Additional difficulties are encountered in using carrier insurance exclusively. The settlement of claims made against a carrier usually requires more time than similar claims against a shipper's own insurers. Moreover, such claims are unusual and if he is not familiar with the kind of article insured, the carrier may require more detailed proof of the cause and extent of the loss. Settlements of this kind often take more time than they are worth.

In general, the standard 'floater' policy relieves the shipper of certain responsibilities in dealing with carriers. Provided the exhibitor declares a proper valuation so as to ensure careful handling, the insurers assume responsibility for collecting claims against the carrier for damage during transit. Furthermore, most 'floater' policies automatically cover shipments regardless of means of transport. The fullest protection is thus afforded by a single policy covering all risks of inland transport, whether by rail, truck or air.

REPORTS TO INSURERS

Most policies require that a report of loss or damage be made within a limited period in

order to place a claim. If a collection is on tour, the claim may be postponed until an item has been returned to its owner at the end of the tour, but the cause and extent of damage must be established when it occurs; circulating agencies depend upon exhibitors to report such conditions immediately. Exhibitors often provide 'condition' sheets on which such reports can be made easily; the sponsoring institution uses this sheet to record the condition of the object at the time of departure, and exhibitors are asked to check questionable items against this record and to make additional reports as necessary. The sheets are not only a convenience to exhibitors but a forceful reminder that reports must be made. As a file on damages they are an important record for the circulating agency (see sample sheet, Appendix I).

AIR FREIGHT INSURANCE

The standard 'floater' policy usually covers air shipment, unless specifically excluded by the contract. In view of the growing importance of air freight transport, any standard policy held to cover loans or shipments should include air coverage. Some contracts, while they do not entirely eliminate air coverage, limit it to 50 per cent of the top valuation insured for rail or truck shipments. Valuations, to the limits specified in the policy, can be covered by endorsement. Moreover, the usual breakage clause in insurance contracts remains valid for air transport.

OCEAN FREIGHT INSURANCE

Standard 'floater' policies do not afford coverage during ocean transit unless this is specifically provided for. As in inland insurance, the 'open cargo' or 'floater' policy form is the most satisfactory because it automatically covers shipments, whether or not the shipping date is known to the exhibitor. Details must be reported as soon as they are known, but the insurance is valid during the interim. Coverage usually goes into force from the time the property leaves the point of shipment and remains in force until

its delivery at the final point of destination. This is called 'warehouse to warehouse' coverage.

Valuations must be declared prior to shipment, and both shipper and insurer must agree to third party arbitration should any dispute arise over them. The valuation declared to the shipper and the type of stowage provided aboard have considerable bearing on the rate of premium charged. Most ocean bills of lading limit the carrier's liability to \$500 per packing case unless a higher value is declared, for which an increased freight charge is made. Preferred stowage can usually be obtained for shipments of works of art without any increase in freight rate and many insurers insist that shippers request this preferred stowage and handling for such shipments. Shippers should ascertain in advance whether or not the steamship company will issue preferred stowage without the declaration of excess value. The saving in insurance premiums effected by obtaining this special handling and stowage may in any case offset the extra freight charges so incurred.

The insurance contract should not contain clauses specifying special stowage, special handling or the packing and unpacking of goods by competent packers. All shippers should be able to guarantee such conditions, otherwise their insurance is not valid.

Because the first insurance on property in transit was written to protect against loss through 'perils of the sea', marine insurance has acquired considerable weight of precedent. Thus we find that ocean marine contracts are more restrictive as to assumption of risk and less amenable to change. It is wise, therefore, to consider carefully all clauses in a marine insurance contract to make certain that all coverage necessary is included and that no responsibilities are placed upon the policy-holder that he cannot fulfil. These policies may include coverage against many kinds of damage; the more hazards covered, the higher the premium rate. Commodities of low value and those less susceptible to damage may be insured with limited coverage; works of art, however, require the maximum protection of an 'All-Risk' insurance. Because particular conditions pertain to each collection shipped overseas, many museums write

specific policies for each exhibition rather than covering these risks in endorsements to their regular 'floater' policy.

EXCLUSIONS FROM GENERAL 'FLOATER' POLICY

The normal all-risk fine arts 'floater' policy does not cover objects loaned to exhibitions on fairgrounds or expositions. Arrangements for insurance under these conditions must be made separately because the legal complications of suit against a government, State or municipality are such that special clauses must be inserted in standard policies.

Similar special arrangements must be made to cover objects against risk of 'war, invasion, hostilities, rebellion, insurrection, seizure or destruction under quarantine or customs regulations, confiscation by order of any government or public authority, or risks of contraband or illegal transportation and/or trade'. This clause forms part of standard inland marine policy forms. Insurance against strikes, riots and civil commotions can be effected under a separate endorsement or rider, but actual war risk can be obtained only during the time a shipment is waterborne. Such coverage is primarily against risks resulting from the presence of mines or submarines. War risk coverage on land cannot be obtained unless a government makes provision for it.

Since there is relatively little fine arts insurance, many agents, brokers, claim adjusters and insurance companies are not fully familiar with the subject, and it is therefore wise to select an agent or broker who is experienced in handling and placing fine arts coverage. In most countries with active art museums certain firms or brokers specialize in fine arts insurance (see sample insurance policy for fine arts coverage, Appendix III).

Museum material other than works of art rarely has such high intrinsic and monetary values. When it is comparably valuable, coverage equivalent to that of fine arts policies is recommended. Otherwise ordinary insurance coverage, commercially available according to local conditions, should suffice. However, exceptions normally made should be noted. They include those mentioned above for the fine arts 'floater' policy, and

others, such as 'damages resulting from use of objects or apparatus', 'damages and losses resulting from or during experiments and demonstrations', and 'glass scientific instruments'. For this reason it is recommended that all details of the standard policy form in each country, as well as the provision for special protective coverage of any kind, be examined with great care to ensure that all risks under the specific conditions prevailing are covered.

Some museums do not insure their collections when on permanent exhibition in their own galleries. This is true particularly of large valuable collections which, once installed, are rarely changed, and of many museums owned by governments. Museums with less rich collections, and especially privately-owned museums and those which change even their permanent collections from time to time, or hold loan and temporary

exhibitions, combine with their 'floater' policy for temporary exhibitions, a provision for coverage of at least a part of their permanent collection, even when it is installed in their own galleries or stored in their own storage areas.

The extent and kind of insurance coverage must always be determined in relation to local conditions and needs, as well as costs. It should not be overlooked that for travelling exhibitions the most generous coverage must always be foreseen because of the increased hazards, not only of shipment, packing and unpacking, but of handling by persons unfamiliar with the specific objects. The cost of the insurance premium is a legitimate exhibition charge and should be provided for in the budget of every travelling exhibition, no matter what precautions for safety have been taken.

BIBLIOGRAPHY.

- AMERICAN ASSOCIATION OF MUSEUMS. *Packing and handling of objects*, Committee report, Washington, D.C., 1948.
- ARTS COUNCIL OF GREAT BRITAIN. *Exhibition regulations*, 1950.
- DUDLEY, Dorothy H. 'Problems of importing and exporting works of art', *The museum news*, Washington, D.C., The American Association of Museums, 15 October 1949.
- ; BEZOLD, Irma, *et al. Museum registration methods*, Washington, D.C., The American Association of Museums, 1958.
- HUYGHE, R. *Co-ordination of international art exhibitions*, Paris, International Council of Museums, 30 June 1950.
- 'A collection of modular framing systems for interior designers', *Interiors*, New York, December 1950.
- LEEMING, Joseph. *Modern export packing*, Washington, D.C., United States Department of Commerce, 1940.
- MISSINGHAM, Hal. Travelling art exhibitions to country centres in New South Wales', *The Museum's Journal*, April 1949, vol. 49, p. 12-14.
- *Art for the nation*, New York, Museum of Modern Art, September 1940, vol. VII, Bulletin 5.
- *Museum*, Paris, Unesco, 1950, vol. III, no. 4; *ibid.*, 1951, vol. IV, no. 1.
- SUGDIN, Robert F. 'Routine Museum Packing', *The Museum News*, Washington, D.C., The American Association of Museums, 1 September 1947.
- *Safeguarding works of art*, New York, Metropolitan Museum of Art, 1948.
- UNITED NATIONS. *Agreement on the importation of educational, scientific and cultural materials*, Lake Success, 1950.
- UNESCO. 'Explanatory note on preparation and circulation of exhibitions by Member States', annex, circular letter 589, Paris, January 1952.
- *Museum*, 1950, vol. III, no. 4, *ibid.*, 1951, vol. IV, no. 1.
- *Report of the rapporteur*, Joint Unesco-ICOM Meeting of Experts on Museums and Education, Paris, February 1952.
- *Trade barriers to knowledge*, Paris, 1951 (revised and enlarged, 1955).
- *The organization of museums: practical advice*, Paris, 1960. (Museums and Monuments series, IX.)
- *Protection of cultural property in the event of armed conflict* (revised and enlarged from the original French text of A. Noblecourt, August 1956), Paris, 1958. (Museums and Monuments series, VIII.)

I. EXAMPLES OF FORMS SENT OUT WITH TRAVELLING EXHIBITIONS

Typical examples of forms usually sent out with travelling exhibitions are shown on the following pages.

1. NOTIFICATION FORM

2. PACKING AND UNPACKING INSTRUCTIONS

- (a) Printed card enclosed with the instructions for unpacking. This is also printed on a gummed label in red ink and appears on the cover of each packing case to call attention to the packing and unpacking instructions.
- (b) Special instructions regarding gummed tape are enclosed with all exhibitions including pictures with glass.
- (c) Unpacking instructions also appear on the cover of each case but a copy is sent to each exhibition with the first form letter so that any unusual caution will be understood by the person in charge of the exhibition and directions to those who will handle unpacking can be issued in advance.

Packing instructions are incorporated on the same page with unpacking instructions so that exhibitors will note how the material removed is to be replaced in the case. These instructions are also attached to the cover of each case.

3. CHECK LIST

An itemized list of the contents of an exhibition gives the exhibitor a guide by which he can easily and swiftly assemble the collection in the order of presentation.

4. RECEIPT CARD

The prompt return of this card to the circulating agency informs it of the safe arrival of the exhibition at its intended destination. It is issued to allow the exhibitor a quick reply without the necessity of full correspondence.

5. CONDITION REPORT

This form was arrived at after considerable experience. It was found that exhibitors, because of the pressure of their other duties, often delayed writing in detail about damages until it was too late to make repairs or claims to insurers before the next shipment had to be made. Such practice leads to further damage and an inability to trace conditions which have caused damage to occur. The exhibition contract specifies that this form be filled out promptly and returned to the circulating agency. When this agency carries insurance on all items contained in an exhibition, this form permits an instant report to the insurers. Having one policy and a record of conditions when the exhibition starts on tour, it is a simple matter to check the condition of the material against this record at each stop and to ascertain when and how damage may have occurred.

1. NOTIFICATION FORM

THE MUSEUM OF MODERN ART

11 West 53rd Street, New York 19, N.Y.
Department of Circulating Exhibitions

Form 1

EXHIBITION:

ENGAGED FOR:

WILL BE SHIPPED TO YOU FROM:

ON:

BY:

WEIGHT:

APPROXIMATE TRANSPORTATION CHARGE:

ENCLOSED ARE ITEMS CHECKED:

Unpacking Instructions. Please follow with care.

Packing Instructions. Please follow with care.

Check List. Check each item against this when unpacking.

Installation List. Follow this order as closely as feasible in your space.

Publicity Release. A suggested form. Please note contract conditions for publicity.

Receipt Card. To be filled out and returned promptly to the Museum of Modern Art.

Condition Sheet. To be filled out and returned promptly to the Museum of Modern Art.

PUBLICITY PHOTOGRAPHS:

Available on request for items checked in red on Check or Installation List. (Any returned in good condition will be credited.)

Price:

INSTALLATION PHOTOGRAPHS:

Available on request.

CATALOG:

Available on request.

Price:-

SPECIAL INSTRUCTIONS:

1. If you do not receive this shipment within . . . of your opening, please wire us.
2. Shipping address will be sent shortly before your closing date; please hold exhibition for notification from us.

2(a). PACKING AND UNPACKING INSTRUCTIONS

IMPORTANT—NOTE CAREFULLY

Before you take out the contents of this case please take a good look at the way it is packed. Observe especially the exact position of any battens and/or protective pads. This packing has been carefully designed to give the greatest possible protection to the contents of the case.

When you re-pack the material to return it to us, please do it in exactly the same way.

If a work of art returned to us is received in damaged condition, but is found to have been packed as it was when sent out, the responsibility will rest with the transportation company. *If, however, it was not so packed the granting of future loans by us will be jeopardized.*

CITY ART MUSEUM OF ST. LOUIS

2(b). PACKING AND UNPACKING INSTRUCTIONS

PLEASE NOTE

IMPORTANT INSTRUCTIONS REGARDING GUMMED
TAPE ON PICTURES COVERED WITH GLASS

1. Every picture covered with glass should be taped with strips of gummed tape *not more than 1/2 in. apart.*

When pictures start on tour from the Museum of Modern Art they are so taped—with the particular kind of tape that does not require water.

The co-operation of all exhibitors is requested in seeing to it that *tape requiring water is never used as a substitute.* This is to guard against any possible water damage to a picture.

2. In order to preserve tape for use in repacking—*using a sheet of glass, or other slick surface* (any other surface will adhere to the tape and make it unusable), pile strips of tape belonging to each picture on top of each other *smoothly with the numbered piece on top.*

Wrap in paper so that tape will be kept clean and not dry out during the showing of the exhibition.

3. If tape is *too dry* for re-use, *please request a fresh supply well in advance of packing date from:*

Department of Circulating Exhibitions,
Museum of Modern Art,
11 West 53rd Street,
New York 19, N.Y.

DO NOT PUT TAPE OVER LABEL OR FRAME

2(e) PACKING AND UNPACKING INSTRUCTIONS

CARVERS, MODELERS AND WELDERS, 1950-52

*An exhibition circulated by
the Museum of Modern Art, New York, N.Y.*

UNPACKING INSTRUCTIONS:

*Box No. 1. 1 stone sculpture 50.921 Salerno: Horse & Clown.
Wood base for 50.921*

1. Lift out package containing wood block base for sculpture.
2. Unbolt Brace No. 1 and Brace No. 2 from outside of box. Lift out braces. Replace short bolts in braces.
3. Lift wrapped sculpture from box. *Caution: sculpture weighs 124 pounds. Two men should handle the piece.*
4. Replace 2 corrugated boards and wrapping paper from package, 2 braces with bolts in ends, cloth, in box and put on lid making sure all bolts are saved.

PACKING INSTRUCTIONS:

*Box No. 1. 1 stone sculpture 50.921 Salerno: Horse & Clown.
Wood base for 50.921*

Caution: Sculpture weighs 124 pounds. Handle with care. Two men should handle piece.

1. Wrap sculpture in cloth marked with same number. Tie securely.
2. Place curved short side of sculpture against wide pads at right side of box.
3. Set Brace No. 1 pad against sculpture in marked spot in box. Bolt in place from outside of box.
4. Set Brace No. 2 pad against sculpture in marked spot in box. Bolt in place from outside of box.
5. Wrap wood base for 50.921 between 2 sheets of corrugated board. Wrap in heavy paper and seal. Slide package into marked space at top of box.
6. Bolt lid on box *securely*.

3. CHECK LIST

CHAIM SOUTINE 1951-52

An exhibition circulated by
the Museum of Modern Art, New York, N. Y.

CHECK LIST:

- 1 title poster 18x25
 - 19 identification labels
 - 19 paintings
- } Box No. 3

Museum number	Title and medium	Framed size	Box No.
51.628	<i>Still Life with Soup Tureen</i> , c.1916. Oil on canvas	30½×35¾×1	2
51.629	<i>Village Square</i> , c.1920. Oil on canvas	36½×40½×1	1

4. RECEIPT CARD

THE MUSEUM OF MODERN ART

11 West 53rd Street, New York 19, N. Y.

EXHIBITION:

NO. OF BOXES RECEIVED.....ON.....

If unpacked and in good condition, check here.....

If damaged, please fill out detailed report on Condition Form provided for the purpose.

If to be unpacked later, give approximate date we may expect your report on condition

RECEIPT

.....
(Signature)

5. CONDITION REPORT

THE MUSEUM OF MODERN ART

11 West 53rd Street, New York 19, N.Y.

REPORT ON THE CONDITION OF THE CIRCULATING EXHIBITION
UPON ITS RECEIPT IN..... FOR BOOKING

Please check the material in the exhibition against the check list provided and list below all damages and omissions from the list.

Please note whether in your opinion damage occurred in transit or while in your possession. Describe condition of item in detail.

Museum number	Artist	Title and medium	Description of damage
---------------	--------	------------------	-----------------------

Box condition. If necessary, please request new bolts and washers from the Museum of Modern Art.

.....
(Signature of person in charge)

.....
(Institution)

.....
(Date received)

II. GENERAL RULES FOR HANDLING TRAVELLING EXHIBITIONS

These instructions were prepared by Robert P. Sugden, General Services Manager, Metropolitan Museum of Art, for their publication *Care and Handling of Art Objects*. Permission has been granted by the author to reprint these instructions from the guide-book.

1. No one shall handle, move or carry more than one painting at a time. Carry it with one hand beneath and the other at the side of the picture, both at points where the frame is solid. Never carry a painting by the top of the frame or by the stretcher.
2. Large paintings must be moved by no fewer than two men, one of whom is experienced in correct handling of paintings. (By 'large' is meant large enough to be awkward for one man. It does not mean that it is all right for one man to move anything he happens to be strong enough to lift.)
3. Do not stack paintings—one leaning against another—unless it is absolutely unavoidable, and then only with permission of the curator or other responsible person in charge.
4. Separate paintings with composition sheets (corrugated cardboard, composition board, etc.), if stacking is absolutely necessary. Stack the largest painting first, followed by smaller ones in order, with no more than five paintings in any one stack. Each composition sheet must completely cover the larger of the two paintings it separates.
5. Paintings standing on the floor must rest on pads or padded wooden strips.
6. Separate paintings on side trucks with composition sheets. There must never be so many paintings on a truck that the outside painting or its frame extends beyond the edge of the truck. Pad the floor of the truck to prevent damage to frames.
7. Do not move large heavy paintings on side trucks unless the truck's supporting framework is high enough, that is, at least two-thirds of the height of the picture. The weight must be borne by the frame resting against the truck support; it should never be borne by the stretcher alone.
8. Lash the painting in place before the truck is moved. Two men must accompany each loaded moving truck. At least one of them must be an experienced man.

ADDED PROTECTION FOR CANVASES AND FRAMES

9. When dismantling an exhibition, remove screw eyes, wires, hooks, etc., from the frames as soon as they come from the walls so that neither pictures nor frames will be harmed in transit or in storage.
10. Avoid direct contact with painted surfaces at all times. Do not attempt to remove slight scratches, rubbed spots, or dirt marks with your hand, a cloth, or by any other means. Where varnish is in poor condition, even gentle pressure will leave a mark which may call for treatment of the entire surface.
11. Wear white cotton gloves to avoid damaging fingermarks when working

with light-coloured, matt finish or gilded frames. Clean hands are not enough in this case, as perspiration spots so easily spoil the frames' appearance.

REPORT ALL DAMAGE

12. Report any damage which appears to be of recent origin, no matter how slight it seems to be. Get in the habit of examining paintings to determine condition.
13. If paint flakes or frame parts become detached, save all the pieces. Repairs are much easier if all the parts are available.

CARE AND HANDLING OF SMALL OBJECTS

Ceramics, enamels, glass, etc.

1. Never handle any object unnecessarily. Work with proper supervision.
2. Move only one object at a time and carry it with one hand underneath. Unpack trays over padded tables so that detached parts will not be lost or damaged.
3. Do not lift small, fragile objects by handles, rims, or other projections, for these parts may have been broken and repaired. Hold the body of the piece gently but firmly. Check each object in and out of the tray when it is composed of more than one part. Pack each part separately within the tray.
4. Always use padded trays for moving small objects. Do not move them by hand except for placement in trays. Use sufficient cotton or padding within the tray to prevent contact with other objects. Whenever possible, objects should be so placed that they do not project above the top of the tray.
5. Make sure that hands are clean. Use gloves or tissue when handling objects with glazed, polished metal, or other highly finished surfaces. (All such material shows fingermarks, which are difficult to remove.) Apply this rule to matt finishes and painted decorations as well. Smooth-surfaced objects are hard to handle with gloves or tissue; with them, extra care is necessary.

6. Do not move trays by hand from one part of the building to another. Use the trucks provided for the purpose. Speed and jarring in motion should be strictly avoided. Take time to do the job properly.

Small sculptures

7. To avoid chipping and scratching in transit, small, heavy objects should always be set on pads and carefully supported so that the weight is evenly distributed.

Ivories and wood carvings

8. Ivories and small wood carvings are affected by sudden changes of atmosphere. Do not leave such pieces near open windows or doors particularly during the winter months.

Arms and armour

9. Arms and elements of armour are subject to damage in many ways. Such material should not be handled by the inexperienced except under competent direction. Always handle with gloves as fingermarks cause rust. Any exposure to dampness should be avoided.

Jewellery

10. Never place cotton in direct contact with jewellery. It will catch on delicate parts, may loosen settings, and thus cause loss of stones. Wrap jewellery in tissue first and then in cotton if added protection is needed. (Ivories, enamels, and old glass should be treated in the same way, that is, wrapped in tissue first, then in cotton.) Staff supervision is necessary when working with jewelled objects.

Examine objects to determine condition, then handle accordingly. Report every damage no matter how slight. Save all parts which become detached. Avoid haste in handling objects. Avoid speed with loaded trucks.

CARE AND HANDLING OF LARGE OBJECTS

Sculpture

1. Moving large sculpture is a technical problem. Do not attempt it with too little help or without competent direction. Haste in handling may result in injury to the handlers or damage to the objects.
2. Do not carry heavy sculpture by hand, even if you are able to lift it. It should always be moved on padded trucks, supported and, if necessary, tied to prevent harmful movement while the truck is in motion.
3. Examination of the object before handling is particularly recommended for sculptural material. Knowing the points of weakness in advance is important to the safe movement of the piece. When there is any doubt about whether or not it is strong enough to withstand the strain of transit, get the advice of the person in charge.

Woodwork and furniture

4. Always move woodwork or furniture on trucks or trolleys (dollies). Never slide or push such objects along the floor, for legs and bases are usually in a weakened condition owing to age or previous damage.
5. Always lift chairs under the seat rail, never by the backs or arms. Carry tables and other furniture by the solid parts of their framework, not the ornamentation.
6. Cover upholstered furniture in transit, as delicate fabrics are difficult to clean. Do not touch the upholstery on the arms, seats, or backs of chairs or sofas.
7. Do not overload flat-bed trucks. Placing chairs, etc., on top of tables or other objects is a dangerous practice. Separate pieces of furniture with pads to prevent contact if more than one is placed on the truck at the same time. Do not allow objects to extend beyond the edge of the truck. Unlocked drawers and cabinet doors as well as folding table tops, movable parts, etc., must be held in place

(tied if necessary) to prevent damage in transit.

8. Remove marble tops for transit and transport them in a vertical position on side trucks. Do not carry them horizontally as they may break of their own weight.
9. Wood panelling is seldom as strong as it looks. Movement of it should never be undertaken without sufficient help and proper supervision. As moulding and trim are lightly attached, do not try to lift or move woodwork by projecting parts.

Report every damage which appears to be new. Preserve all fragments which may become detached.

CARE AND HANDLING OF TEXTILES

Tapestries and rugs

1. Never lift mounted textiles so that all the weight is borne by the fabric alone. Use the supporting bar, roller or stretcher for lifting and handling textiles.
2. Avoid stretching, tugging, and pulling. Textiles which seem to be sturdy are frequently old, worn or repaired. They tear easily.
3. Remove screw eyes, wires, or other projections before rolling textiles on supporting bars. In storage such projections wear through and injure fabrics permanently. Roll tapestries and rugs evenly, avoiding wrinkling and creasing. Roll lined material face out.
4. Rugs and tapestries on rollers should not be picked up by one man or grasped at the middle of the bar. Use two men, one supporting each end, for greater protection of this type of material in transit.
5. Do not pile rolled or folded textiles one on top of another unless it is absolutely necessary. This practice results in broken threads which are virtually impossible to repair.
6. Observe safety rules when removing rugs and tapestries from exhibition. There should be a man at the foot of each ladder in use to steady it.

Costumes and small textiles

7. Handle mounted textiles by the stretcher or frame. Even slight pressure on tightly stretched fabrics causes serious damage.
8. Avoid folding textiles, laces, costumes, etc., wherever possible. If it is necessary to fold them, tissue paper should be placed in the folds to prevent creasing.
9. Clean hands are essential in working with textiles. Many fabrics are so fragile that cleaning is impossible.
10. Cover costumed manikins in transit and in temporary storage. They should be lifted by the framework when moved, to avoid soiling or tearing the costumes.
11. After removing textiles, costumes, etc., from exhibition, be sure that all pins are removed to prevent rust stains and blood stains from scratched fingers.

Work on textiles should be done under staff supervision. Report any damage which appears to be new.

CARE AND HANDLING OF WORKS ON PAPER.

Works in this group are among the most fragile and easily damaged in the museum. Treat them with the consideration they deserve. They are not to be handled unless it is your job to do so and then only under proper supervision.

Drawings, watercolours, prints, miniatures, etc.

1. Handle as little as possible and only with clean hands. Never touch material of this kind with wet, sticky or dirty hands.
2. When moving unmounted material, lift each sheet by the upper corners so that it hangs free without buckling. Use great

- care to avoid bending, cracking and tearing. Support such works on clean cardboard when carrying them by hand.
3. Never stack prints, drawings, etc., one on top of another unless they are matted or are separated by cellophane, glassine or tissue paper. Do not allow newsprint, printed matter or other paper of poor quality to come into direct contact with the objects. Cover works awaiting installation or transportation with tissue paper to exclude dust and dirt.
4. Do not permit works on paper to be shuffled or rubbed against each other. Difficult and expensive retouching is the only way in which damage done in this manner can be repaired.
5. Do not expose prints, drawings, watercolours, and illuminated manuscripts to direct sunlight whether on exhibition, awaiting installation, or in storage.

Rare books

6. Many bindings which appear to be in good condition are extremely fragile. Leather bindings are easily stained. Do not handle rare books unless it is necessary for you to do so.
 7. Turn the pages from the upper, outer corners when it is necessary to open books. Moistened fingers are extremely harmful to paper.
 8. Open books gently so as not to crack the bindings—that is, never try to make an open book lie flat. Never stack open books one on top of another. Do not place open books face down. Do not stand books on their front edges, whether on tables, trucks or shelves.
- Report every new damage no matter how slight. Save all fragments which become detached.

III. SAMPLE INSURANCE POLICY FOR FINE ARTS COVERAGE

1. This Policy attaches on the 1st Day of November 1951, at noon Standard Time at place of issuance and is deemed to be continuous and expires when cancelled.
2. To cover on Paintings, Books, Manuscripts, Pictures, Prints, Etchings, Drawings (including frames and glass and brackets), Tapestries, Bronzes, Statuary, Potteries, Porcelains, Glassware, Marble and similar objects of Art held by the Assured in trust or for which they may have assumed liability or which they may be instructed to insure, to attach at the time the property becomes at the risk of the Assured.
3. This Policy is to cover the property insured hereunder against all risks of loss or damage to such property (except hereinafter excluded):
 - (a) while on *exhibition* by members of the Western Association of Art Museum Directors or other exhibiting galleries while under the sponsorship of the Western Association of Art Museum Directors;
 - (b) while in *transit* by railroad, express and/or Motor Truck and/or other form of *land* conveyance within the limits of the United States or Canada;
 - (c) while in *transit* by *air service* of the *Railway Express Agency Inc.* and/or by *approved aircraft*; meaning any Civil Aircraft of the United States (excluding Alaska) operated by any American Flag Scheduled Air Carrier holding a Certificate of Public Convenience and Necessity issued by the Civil Aeronautics Board, or Scheduled Air Carriers (civilian) bearing a valid airworthiness certificate issued by the Department of Transportation of Canada.
4. It is understood and agreed that the same coverage as granted to shows sponsored by the Western Association of Art Museum Directors is available to active members and to associate members of the Association, to cover fine arts or other similar materials they own, loan or rent to others, or which they may borrow from others. To avail themselves of this coverage, active members or associate members must notify the Executive Secretary of the Association or the J. Glen Liston Insurance Agency; the Company's agent at Seattle, Washington, on or before the attachment of risk. The policy does not provide automatic coverage on permanent material owned by members, but coverage on such permanent material owned by members may be granted at rates to be arranged for each individual gallery or museum.
5. The amount of insurance provided for hereunder is provisional; it being the intent of this insurance to insure hereunder the value of the property described herein at the agreed net value between the owner and the Assured.
6. It is understood and agreed that the limits of liability of this Company shall be as follows:

Location

Any Museum, Art Gallery or other location 100 000

Motor vehicle

On any one motor vehicle or trailer on shipments of 150 miles or less 50 000

On any one motor vehicle or trailer on shipments of over 150 miles 25 000

Aircraft

On any one aircraft at any one time 25,000

Other carriers

150 000

It is further understood and agreed that the limits of liability of this Company in any one loss, disaster or casualty, whether for partial or total loss or salvage charges or expenses or all combined shall not exceed *Six Hundred Thousand and No/100 dollars* (\$600,000).

7. The Assured hereby agrees to report to this Company through its agent, not later than twenty days (20) after the first day of each month following the date of inception of this policy the total daily average of such property insured hereunder during the preceding month.

8. The Assured agrees to pay premiums monthly at rate of per \$100 based on the monthly report as required hereunder. Shipments by aircraft are to be reported at the following rate:

At and From Points and/or Places within the Continental United States to Points and/or Places within the Continental United States 10 cents per \$100.

9. The named Assured will make every effort to see that:

(a) On shipments via railroad freight a valuation of not less than 50 cents (fifty cents) per pound shall be declared to the carrier.

(b) On shipments via Railway Express Agency Inc. a lot value of \$550 or a value of \$550 per box shall be declared to the carrier on all express shipments.

(c) Due diligence is used in packing and unpacking the property insured under this policy.

10. In the event of the discovery of concealed loss or damage following a transit risk of property insured hereunder, the time and place of said loss or damage not being determined whether it be prior or subsequent to the inception date or subsequent to cancellation date of this Policy, the liability of this Company shall be limited to that proportion of any such loss or damage that the number of days of this Company's coverage of the risk in transit prior to the discovery of said loss or damage shall bear to the total number of days elapsed in transit.

11. This Policy is extended to cover property on exhibition at fairgrounds up to an amount not exceeding Twenty-Five Thousand and No/100 dollars (\$25,000).

The Assured agrees to report such values separately and to pay an additional premium of $\frac{4}{1000}$ dollars (\$.004) per \$100 per day in addition to usual premium required by paragraph eight of this rider form.

12. It is understood and agreed that in the event of the total loss of any article or articles which are a part of a set, this Company agrees to pay the Assured the full amount of the value of such set and the Assured agrees to surrender the remaining article or articles of the set to this Company.

13. This Policy does not insure against:

(a) Loss or damage occasioned by wear and tear, gradual deterioration, moth, vermin, inherent vice or damage sustained due to and resulting

120

from any repairing, restoration or retouching process;

(b) Loss or damage caused by or resulting from:

- (1) Hostile or warlike action in time of peace or war; including action in hindering, combating or defending against an actual, impending or expected attack;
 - (a) by any government or sovereign power (*de jure* or *de facto*), or by any authority maintaining or using military, naval or air forces; or
 - (b) by military, naval or air forces; or
 - (c) by an agent of any such government, power, authority or forces;
- (2) Any weapon of war, employing atomic fission or radioactive force whether in time of peace or war;
- (3) Insurrection, rebellion, revolution, civil war, usurped power, or action taken by governmental authority in hindering, combating or defending against such an occurrence, seizure or destruction under quarantine or customs regulations, confiscation by order of any government or public authority, or risks of contraband or illegal transportation or trade.

14. Other terms and conditions remaining unchanged. Attached to and forming part of Policy No. of the

. Company of
.

Insured:

Agent

NOTE

Clause in basic policy reading:

'It is agreed by the Assured that the property insured hereunder will be packed and unpacked by competent packers.'

has been deleted as superseded.

Clause in basic policy reading:

'In consideration of the agreement by the Assured to report additional items of a nature usually covered under a Fine Arts policy, acquired subsequent to attachment date of this policy, within ninety (90) days from the date acquired and to pay full premium thereon from the date acquired at *pro rata* of the policy rate, this policy also covers such additional items but shall cease to cover such additional items if they are not reported to this Company within the said ninety (90) day period. This Company shall be liable under this provision in respect to any one loss, disaster or casualty, for not exceeding the actual cash value of such additional items, but in no event for more than 25 per cent of the total amount of the Policy exclusive of this provision.'

has been deleted as superseded.

Clause in basic policy reading:

'If the Assured cancels, earned premiums shall be computed in accordance with the customary short rate table and procedure. If the Company cancels, earned premiums shall be computed *pro rata*. Premium adjustment may be made at the time cancellation is effected and, if not then made, shall be made as soon as practicable after cancellation becomes effective. The Company's check or the check of its representative mailed or delivered as aforesaid shall be a sufficient tender of any refund of premium due to the Assured.'

has been deleted as superseded.

Clause (c) in basic policy reading:

'Loss or damage occasioned by breakage of statuary, marbles, glassware, bric-a-brac porcelains, and similar fragile articles, unless caused by fire, lightning, aircraft, theft and/or attempted theft, cyclone, tornado, windstorm, earthquake, flood, explosion, malicious damage or collision, derailment or overturn, of conveyance, unless endorsed hereon.'

has been deleted.

ILLUSTRATIONS

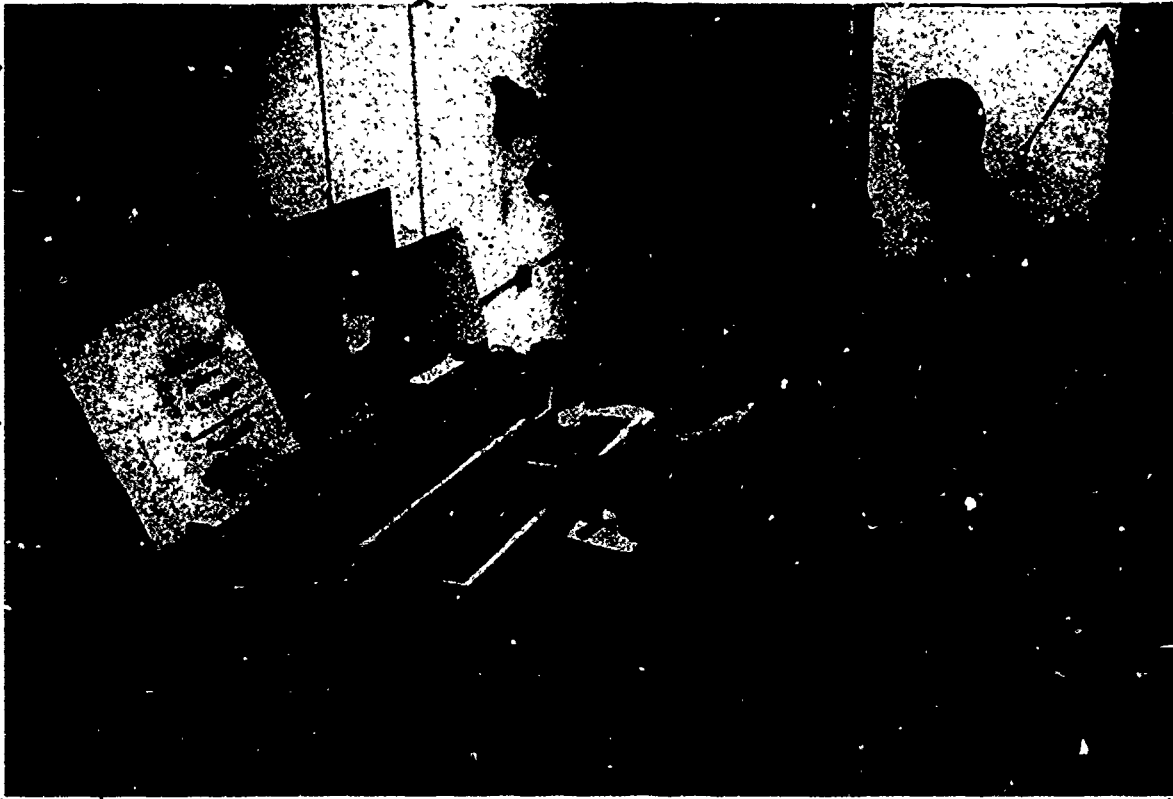

1. Scale models used in the planning of the Hall of Oil Geology, a semi-permanent exhibit, at the American Museum of Natural History, 1954. (Photo: Standard Oil Company of New Jersey)

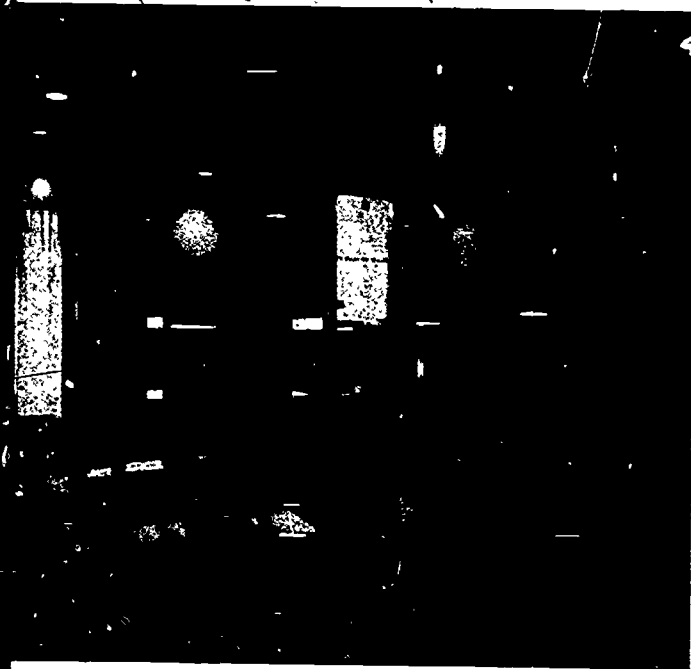

2a, 2b. The Manuscript Room at the Interchurch Center, New York, uses a compression pole system. The flexibility of cases, which can be attached in either horizontal or vertical positions, is one of the system's greatest merits. The poles have an equal-armed cross-section, permitting attachment of cases on all faces. The flexible grid pattern of poles makes various combinations of layout possible.

The lighting arrangement is also extremely flexible. Individual light units can be moved by sliding them to any position on the track, or they can be removed altogether (See also Fig. 7).

'Exhibit system' designed by Witteborg and Gardiner, 1960. (Photos: Lee Boltin).

2a

2b





3. Bower Birds of New Guinea, a temporary exhibit at the American Museum of Natural History, 1957. An intimate exhibit was created for the cases inside by the use of flat 'wallboard' construction on wooden uprights integrated with dramatic colour and lighting. (Photo: American Museum of Natural History, New York)

4. Part of an exhibit on birds at the American Museum of Natural History installed in 1959. Labels, art-work and photographs reproduced on photographic paper, then mounted on masonite. The eggs, bird study skins, and accessories are mounted on the photographic panels. Large letters are die-cut cork, which can be obtained commercially. The small panels are held away from the large background panel by keyhole blocks. (Photo: American Museum of Natural History, New York)

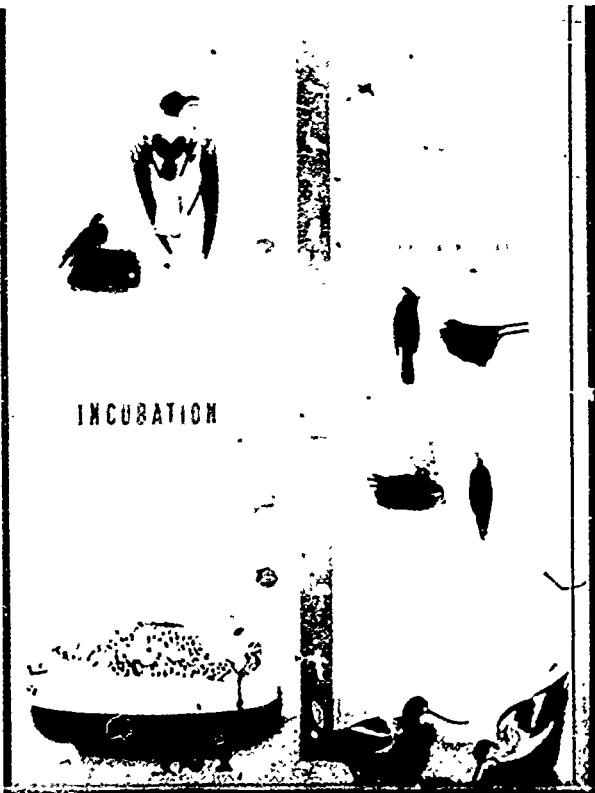

5. Part of an exhibit on birds at the American Museum of Natural History installed in 1959. Silk-screen labels and art-work on large panel. Birds and their nests were wired to the background panel. (Photo: American Museum of Natural History, New York)



7. Japanese exhibit at the World Trade Fair held in New York in 1957. Here again, simple wood construction plus panels (to hide the light source) is used most effectively. (Photo: Lothar P. Witteborg)

8. German pavilion at the Brussels World Fair 1958. A square tubular exhibit system, bolted together, served as the major panel-holding unit in the pavilion. The system also contained light units which were quite unobtrusive. Plants were added as a foil to the rigid structural system. (Photo: Lothar P. Witteborg)

6. Irish exhibit at the World Trade Fair held in New York in 1957. This exhibit illustrates the effective use of raw wood as an exhibit structure. (Photo: Lothar P. Witteborg)

7

8







9. Swiss pavilion at the Brussels World Fair 1958. In one area of the Swiss pavilion enlarged photographs were used to convey many of the cultural activities of the country. The stark simplicity of this setting helped to convey the message and labels were kept at a minimum. The structural system is quite simple, using standard plumbing pipe, braced internally to the photographic panels. (Photo: Lothar P. Witteborg)



10

11. An exhibition of sculpture, some of which were shown in the open air and others sheltered within the gallery. (Photo: Rhodes National Gallery, Salisbury, Southern Rhodesia)

12. A simple wooden panel system designed at the American Museum of Natural History, New York, was used for many temporary exhibits, e.g., 'A Fossil Comes to Life'. (Photo: Lothar P. Witteborg)

10. Italian pavilion at the Brussels World Fair 1958. A rather bold mounting technique of panels, exhibit cases, etc., was used in this exhibit. In this illustration black strap iron was used to good effect in showing an enlarged photo-mural of an antique map. Wrought iron, welded together and mounted in front and away from the map surface clearly pointed out how the shape of Italy had changed with the use of modern surveying methods. (Photo: Lothar P. Witteborg)

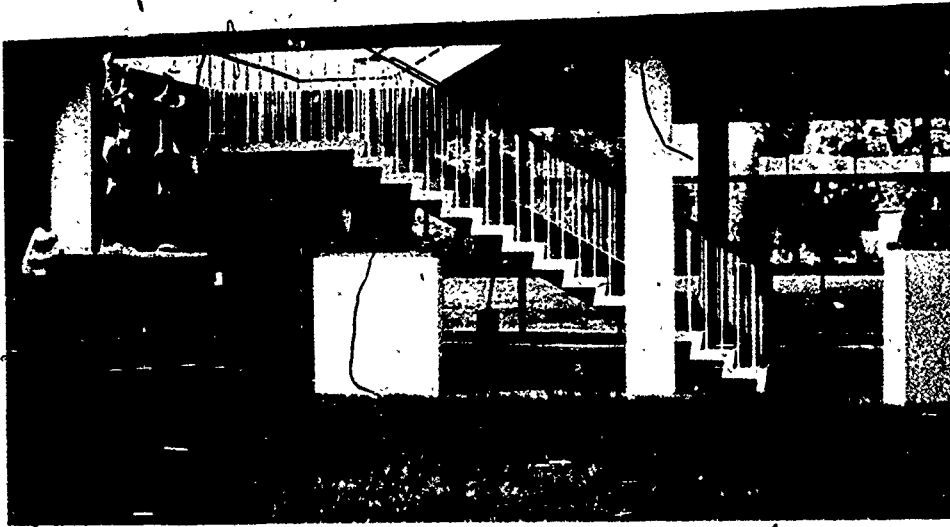
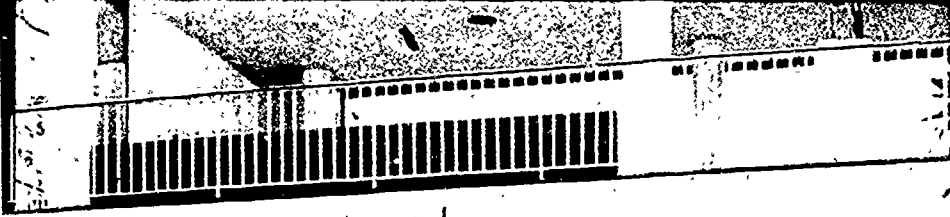

11



12

13a

13a, 13b, 13c. Haniwa, Japanese Burial Mound Figures. An exhibition shown in the National Gallery of Art, Smithsonian Institution, in 1960. (a) The canted black partitions lead the eye towards a single Haniwa figure mounted on a pedestal protected with glass. (b) Haniwa figures were mounted on circular platforms of varying height set on an island, 16×40 ft., containing egg-sized river pebbles. Note the concealed spotlights focused on the platforms. Mahogany pedestals were set along the wall containing ceramic figures and examples of *Jomon* and *Dogū* pottery. (c) The end of the exhibition was marked by two large pedestals showing examples of *Jomon* earthenware vessels and figurines with a hedge of live bamboo set behind them. (Designers: R. B. Widder and B. W. Lawless, Smithsonian Institution, Washington, D.C.; photos: Smithsonian Exhibits Laboratory)

13b

13c

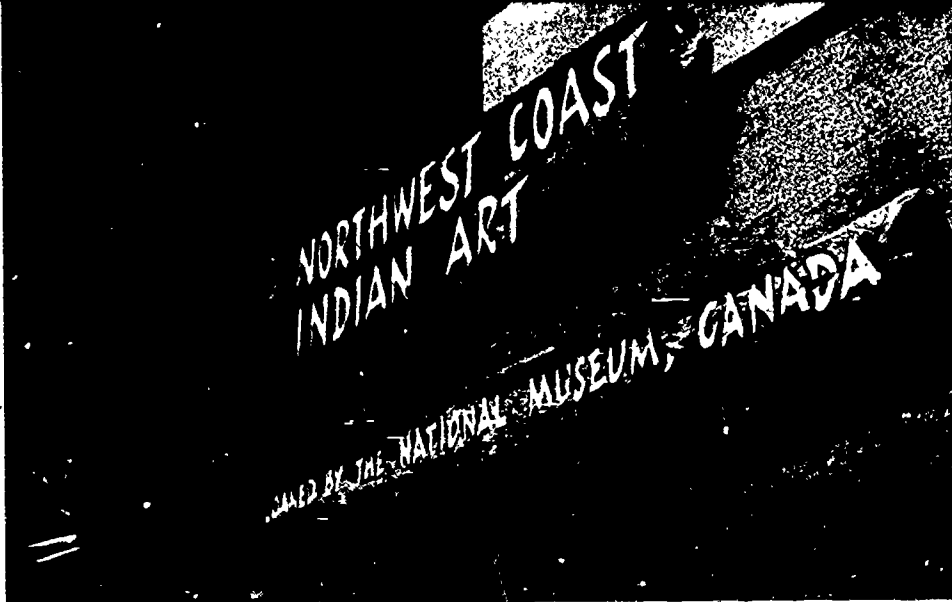

14

14. North-West Coast Indian Art, a loan exhibit at the University Museum, Florida State University, 1951. Natural weathered planks provided the entrance and title panels for this exhibit. (Photo: Lothar P. Witteborg)

15. Pittsburgh Portrait, a temporary exhibition at the Carnegie Museum, Pittsburgh, 1959. A flat panel arrangement was used with 'gooseneck' lighting. Effective enlargements of photographs accompanied by simple charts and graphs make a straightforward exhibition of the beautification process taking place in Pittsburgh. (Photo: Carnegie Museum, Pittsburgh)

15



16a

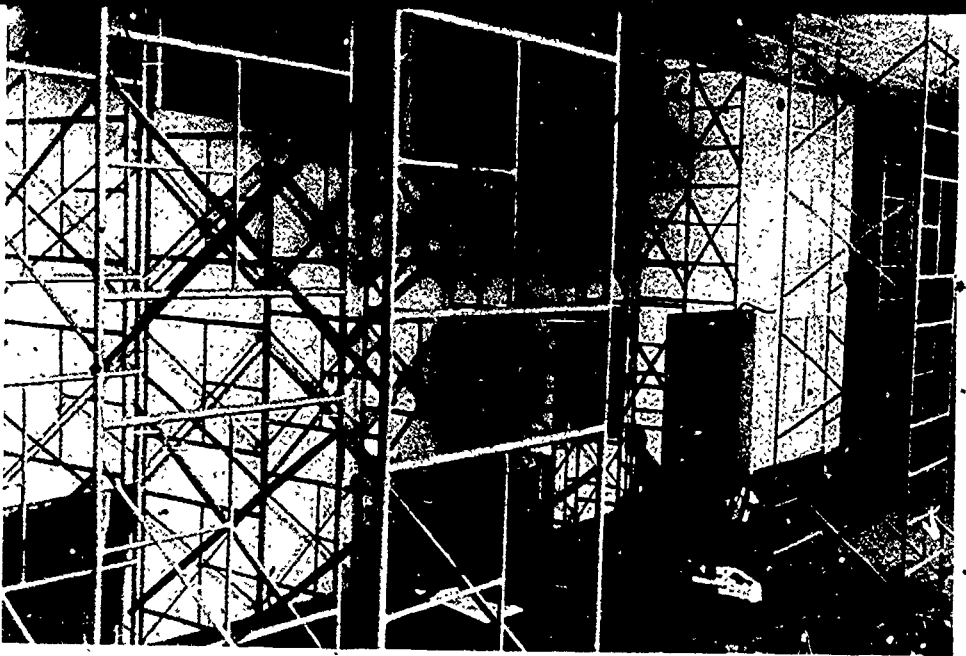

16b

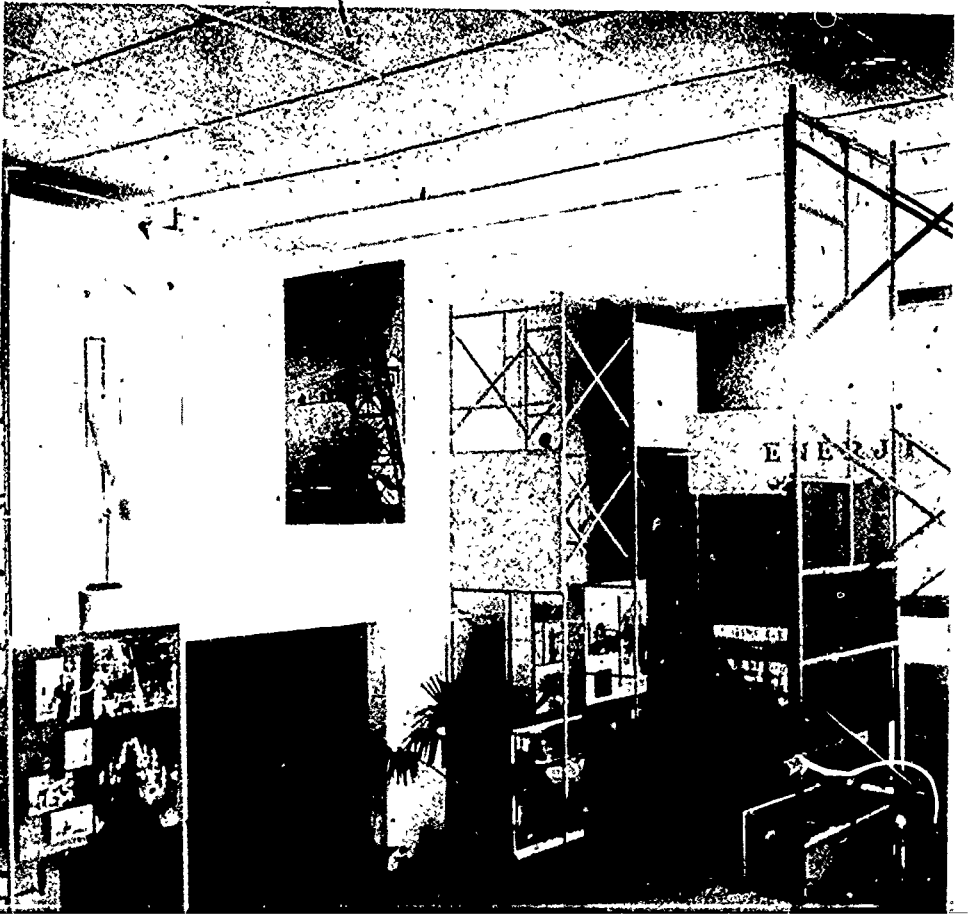

◀ *Fig. 15* A United States cultural historical exhibit in Izmir, Turkey, 1956, designed by E. Otto Wittborg and Henry Gardner. The main structural system used in this exhibit was a structural steel 'mason's' scaffolding. Exhibit panels of braced masonite were hung on the scaffolding by strap iron hooks. Most of the

lighting was concealed behind the panels for downward illumination. Platforms were made by placing horizontal panels to the horizontal members of the scaffolding structure; three-dimensional materials could then be effectively exhibited. (Photos: Henry Gardner).

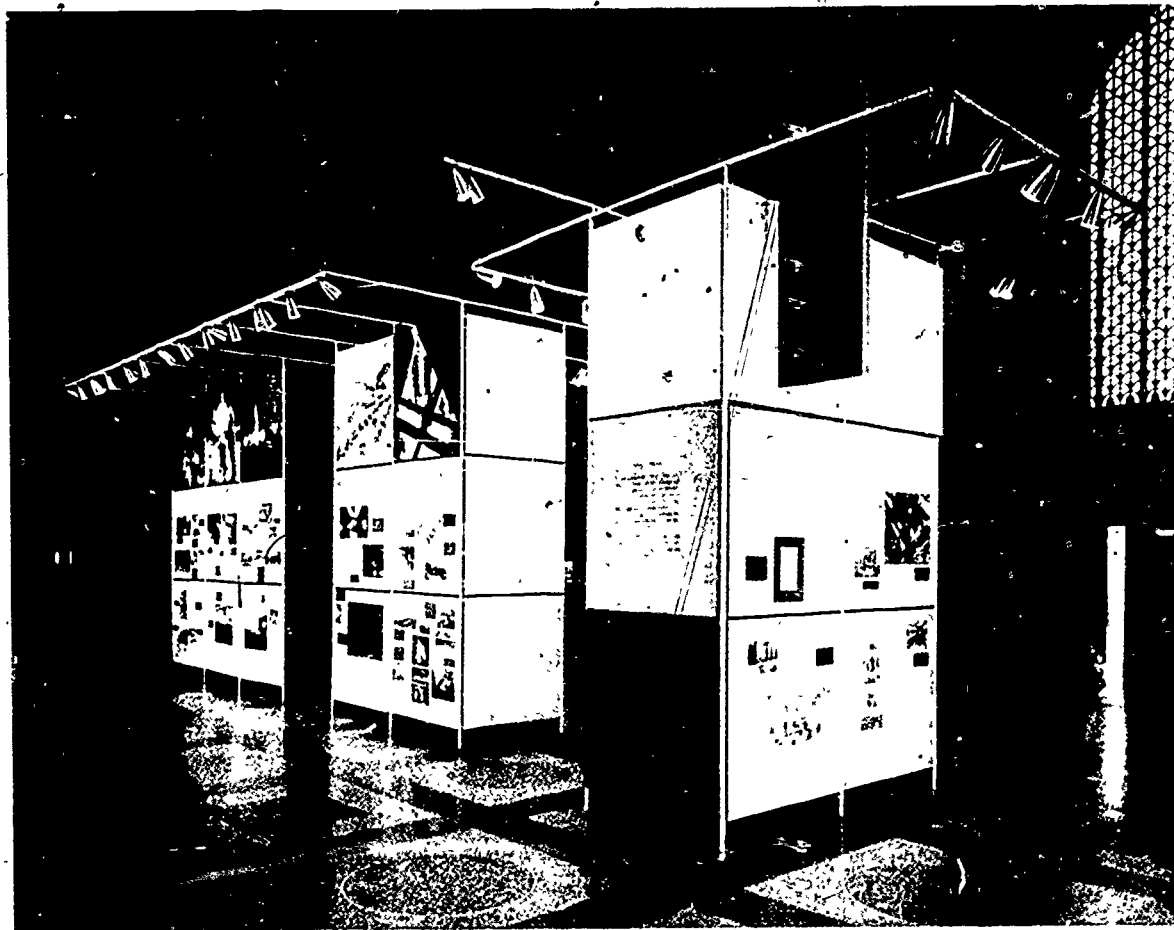
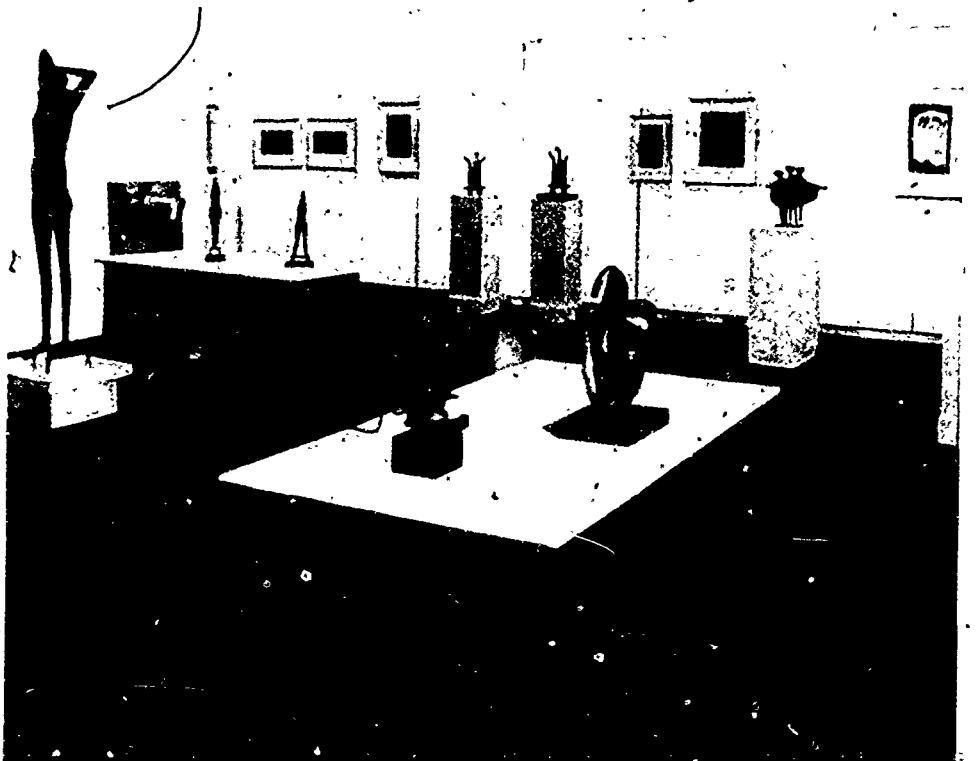

Fig. 17 'To Make to Know How', a temporary exhibit at the American Museum of Natural History, 1957. The same structural mason's scaffolding was used here as in the Izmir exhibit (Plates 16*a* and *b*), with long panels hung directly on the scaffolding. The lighting system was hung on standard plumber's pipe and conduit channel. (Photo: American Museum of Natural History, New York)



18a

18b





18

19



18, 19, 18, 19. An exhibition of the works of young British sculptors shown in four different cities demonstrating the differences which result from the buildings, shape of the galleries, available lighting conditions, etc. (a) Art Gallery of Toronto, 1956. (b) Arts Club, Chicago, 1955. (c) Chadwick-Hitchens Exhibition in the Wigner Secession, 1956-57. (d) Venice Biennale 1956, British Pavilion. (Photos: The British Council)

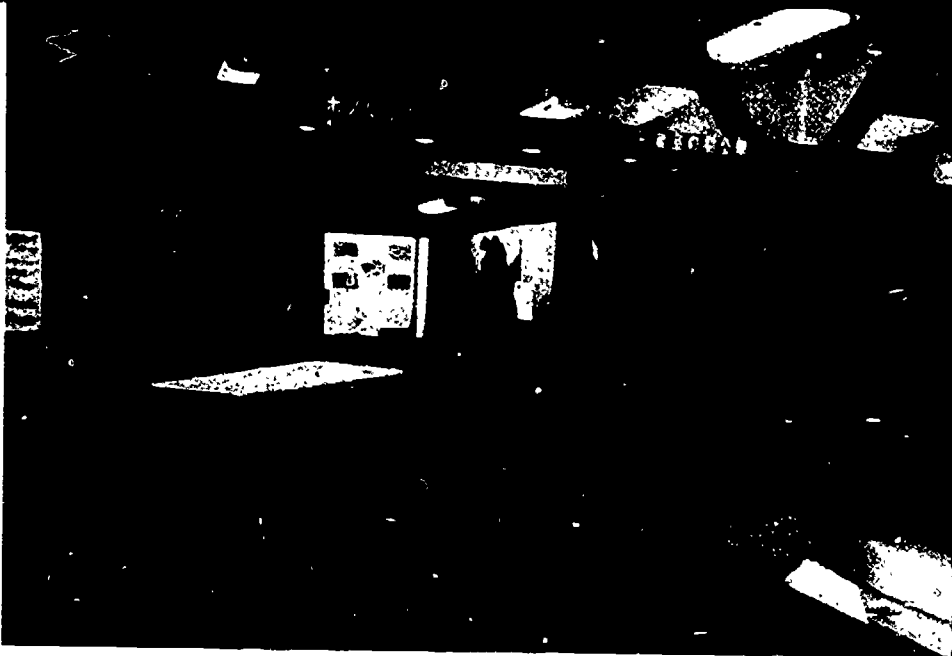

19a

19a, 19b. The Honolulu Academy of Arts and the Bishop Museum of Honolulu co-operated in preparing this exhibition which shows the indigenous art of Hawaii, supplemented by paintings and photographs, and illustrates life under the Kamehameha dynasty. The exhibition was circulated in several cities in Japan during the autumn of 1959 under the sponsorship of the Tokyo National Museum, the Yomiuri newspaper companies and the United States Embassy. (a) Entrance to the exhibition shown

in the Shirokiya department store of Tokyo (as a public service many large department stores show important exhibitions which are organized by museums in Japan). The objects shown near the entry and in the introductory hall set the theme of the exhibition. (b) A central island showing examples of ancient religious sculpture with a wall-case and a free-standing case in the background which illustrate the theme of the exhibition. (Photos: Yomiuri Shimbun)

19b

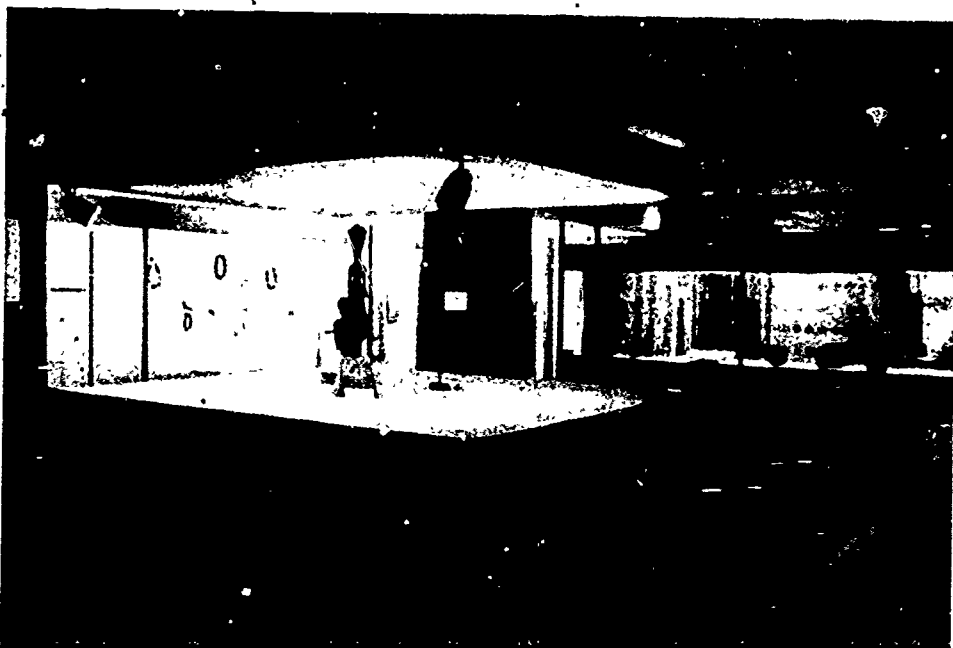

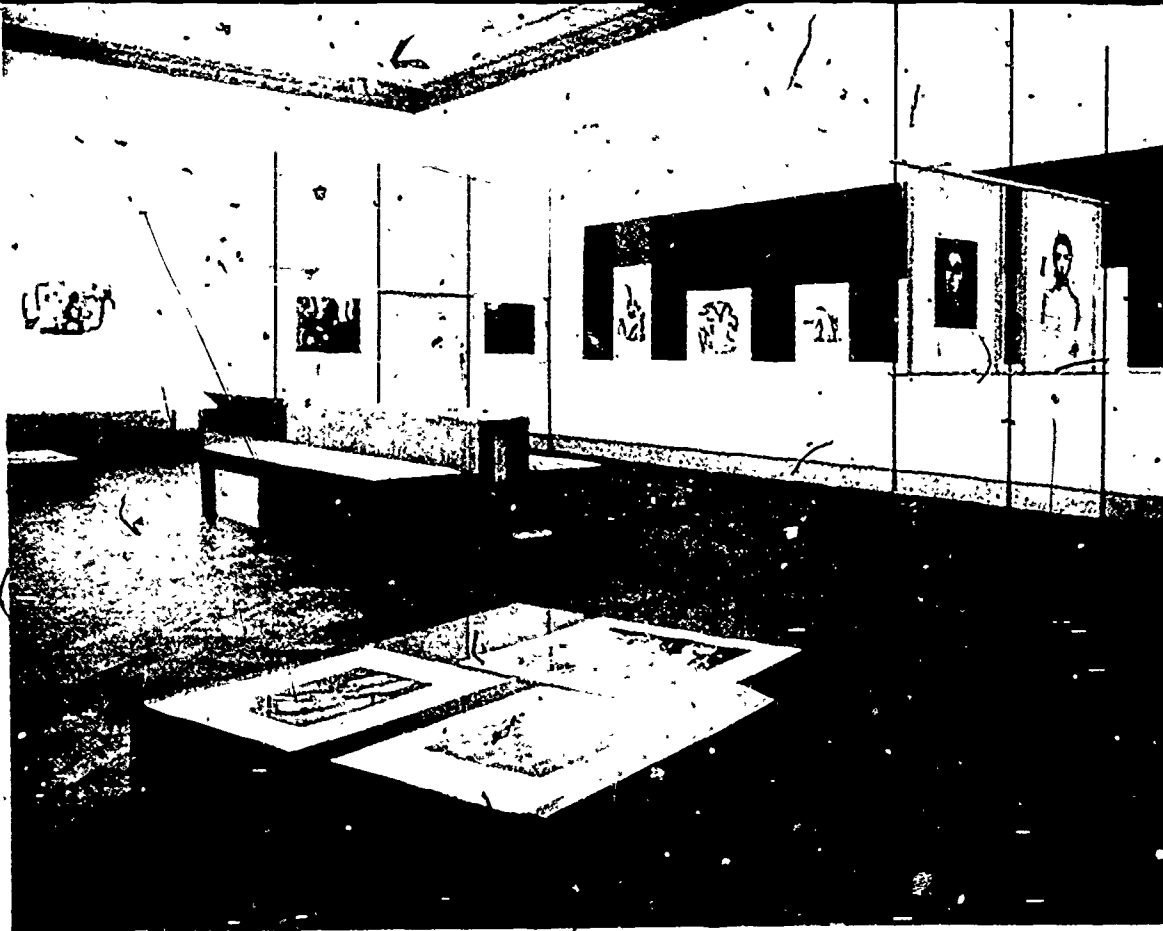

20a

20b

20a, 20b. Illustrating the use of varying means of presentation to accentuate or differentiate between different objects on display. (a) Graphic material has been mounted on vertical panels supported by poles hung from wires strung from wall to wall, on platforms and on panels set at an angle against the wall. (Photo: The Municipal Museums of Amsterdam) (b) African beadwork mounted horizontally on a table and at an angle on the pyramidal centerpiece. The entire unit revolves slowly to attract interest and vary lighting. (Photo: Rhodes National Gallery, Salisbury, Southern Rhodesia)

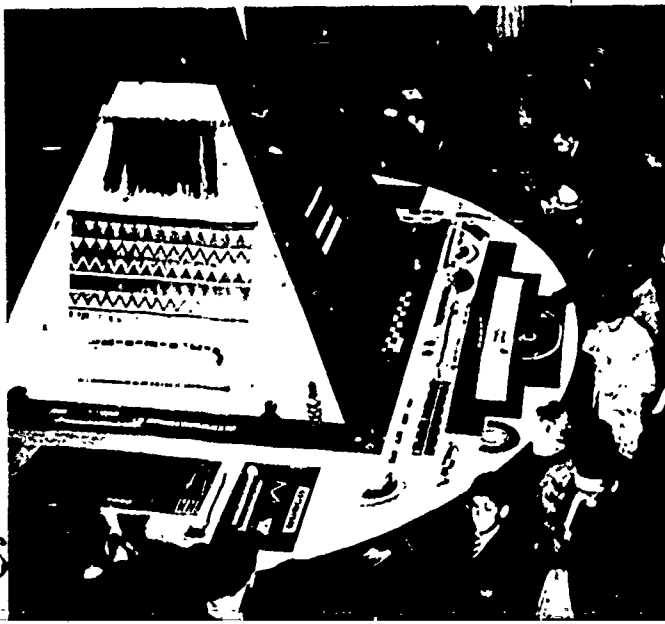



21a

21a, 21b. (a) An exhibition of prints of flowering plants. They are mounted on black flock-covered paper which simulates a background of black velvet. The old-fashioned walls and ceilings of the hall have been masked with bleached jute so that they do not conflict with the exhibition. These temporary coverings are inexpensive and simple to install or dismount,

(b) The Evolution of Vertebrates and the Origin of Man exhibition, May 1958, at the Muséum d'Histoire Naturelle, Paris. Schematic drawings and black-and-white photographs are used to explain the fossils on exhibition while the actual fossils are shown in cases in the foreground. Similar use is made of bleached jute to cover the walls of the hall. (Photos: Muséum d'Histoire Naturelle, Paris)

21b



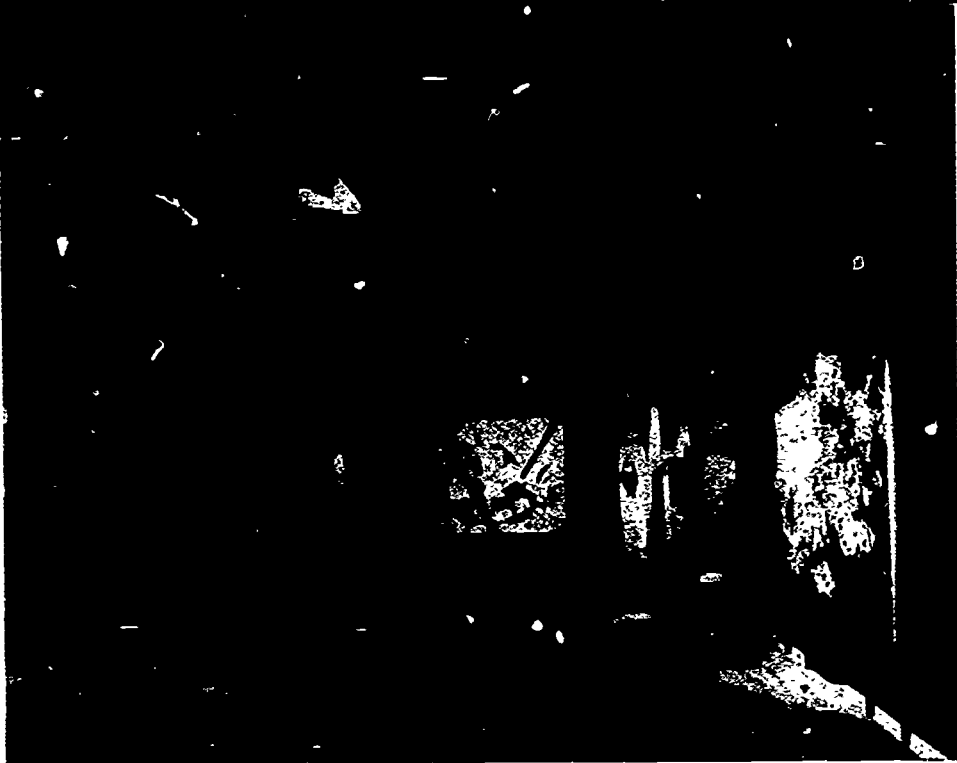

22

22. 'Pogo-stick' panels developed by the Yale Art Gallery. The panels have spring-supported posts, so that they are held in place by tension between the floor and ceiling. They can be readily dismantled and moved for new exhibitions. (*Museum*, Unesco, 1956, Vol. IX, No. 2)

23. An inexpensive system for setting up vertical panels. The upright rods or piping are held in place by a wire strung across the ceiling and the bases may be set in rubber or cork. Lateral rigidity is assured by horizontal bars. (Photo: The Municipal Museums of Amsterdam)

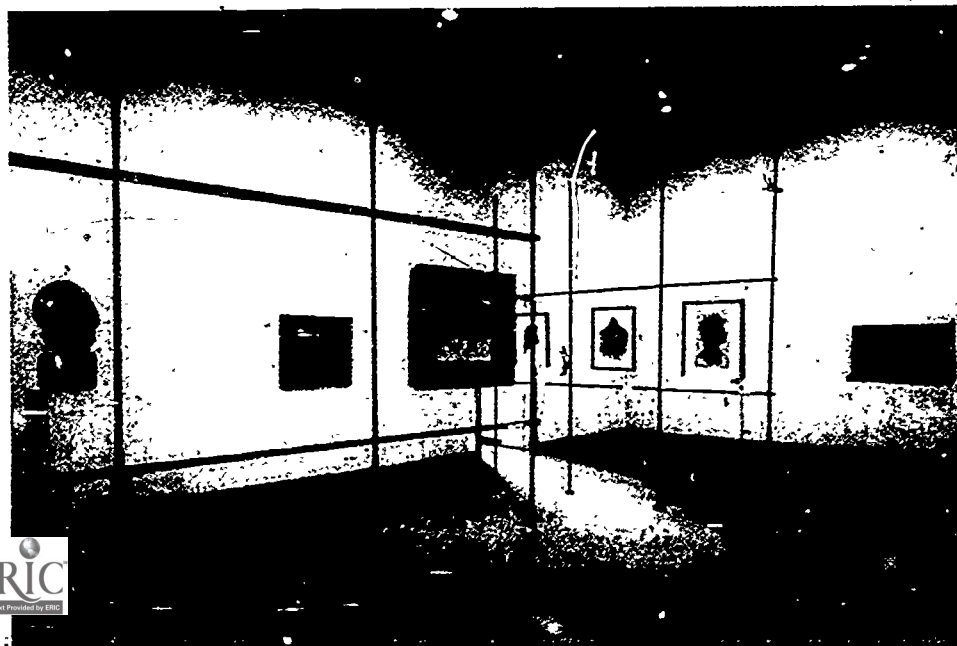

23

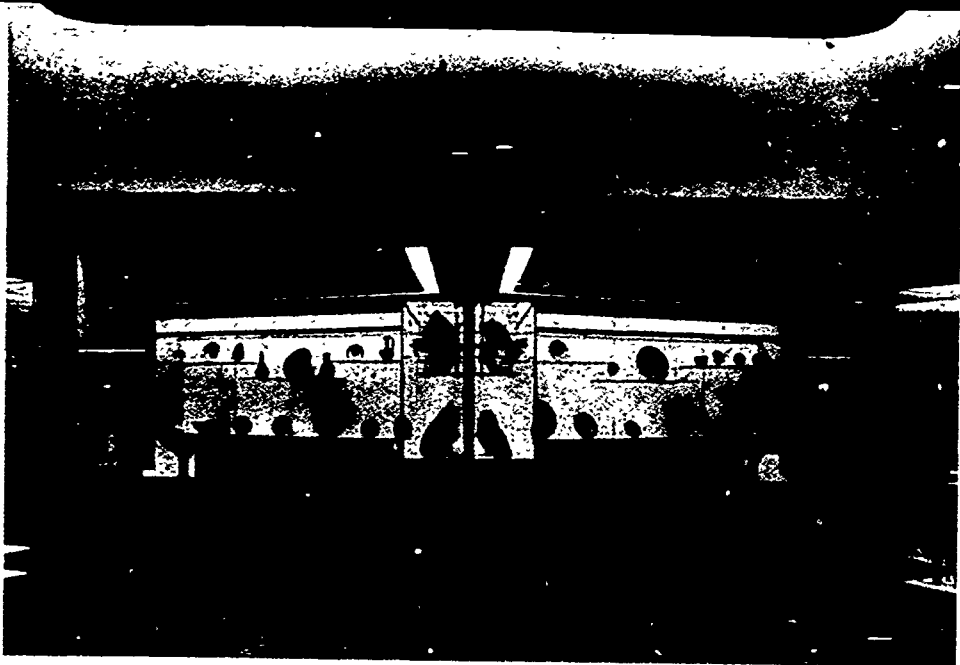

24a

24a, 24b. A temporary exhibition on Iranian art shown in Rome by ISMEO (Istituto Medio Estremo Oriente) in the Palazzo Branceto, 1957. (a) A Y-shaped case. (b) A series of panels and showcases. The framework consists of channel iron and angle iron, mounting wire, screen panels. Analogous systems could be prepared using wood or other inexpensive material. (Designer: F. Minissi; Photos: Vasari, Rome)

24b

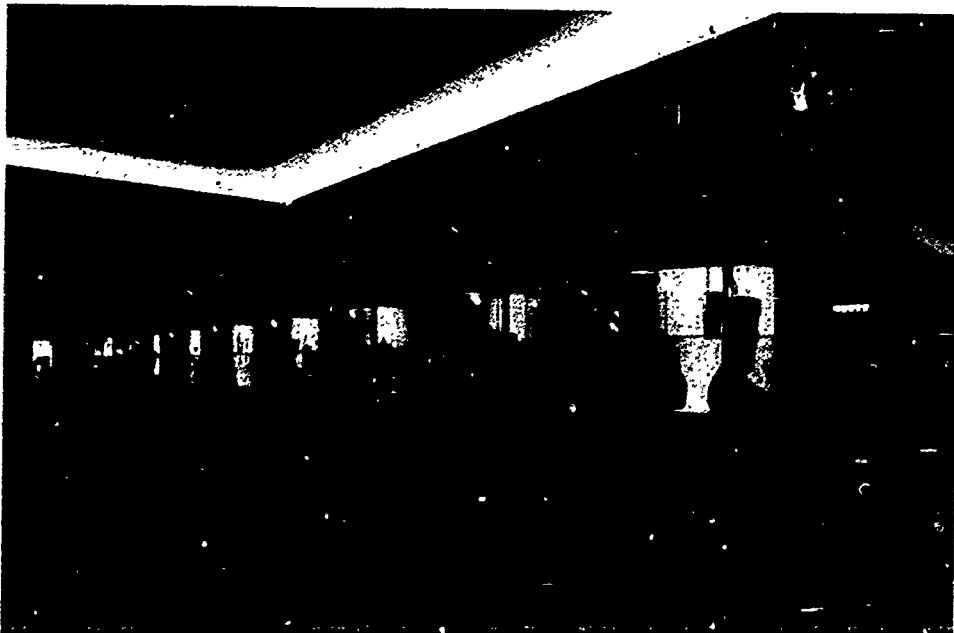

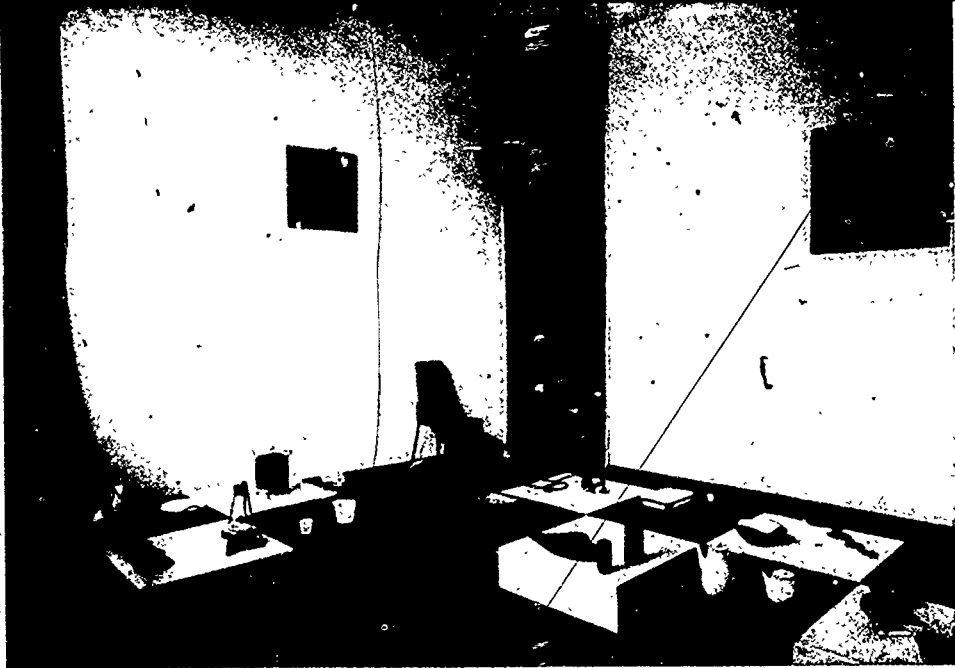

25

25. Low stands showing an exhibition of contemporary household wares. They are simple to build, can be easily arranged in different combinations, and repainted in varying colours for new exhibitions using modern latex paints applied with rollers. (Photo: The Municipal Museums of Amsterdam)

26. An exhibition of the nomadic peoples found in the Sahara. Exhibitions of this type can be used to show the people of a country the manner of dress, habitation, and material technology of other peoples who may live within the same political boundaries, but who may have a different economy, language or tradition. (Photo: Ethnographic Museum of Neuchâtel, Switzerland, 1957)



26



27a

27a, 27b, 27c. (a) An exhibition on the evolution of agricultural machinery and techniques. The 'island' in the foreground shows simple hand tools and animal-drawn implements. In the background, above the dioramas, wrought-iron figures show techniques used in Ancient Egypt as depicted in tomb paintings. The dioramas demonstrate the evolution of implements and techniques. While this is a permanent exhibition, similar ones could be prepared for temporary exhibitions. (b) A diorama showing ploughing techniques current in Western Europe during the Middle Ages (fourteenth century). (c) A diorama showing contemporary machinery using scale models, many of which can be purchased from specialized manufacturers. (Photos: The Science Museum, South Kensington, London)

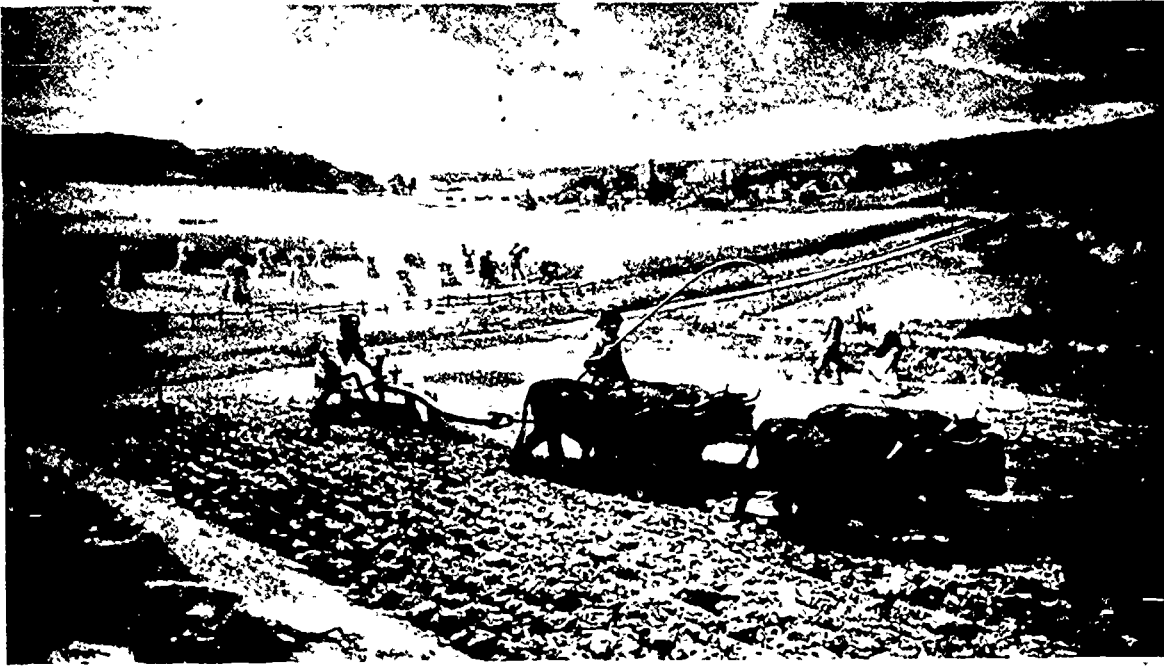

27b



142

27c

28a, 28b, 28c, 28d. (a) (b) (c) A travelling exhibition prepared by the German Health Museum of Cologne. All the units were designed to fit into a small van and to be set up in schoolrooms, gymnasiums, and similar locations. The basic unit is a simple metal tubular system which is clamped and screwed together.



28a

28b

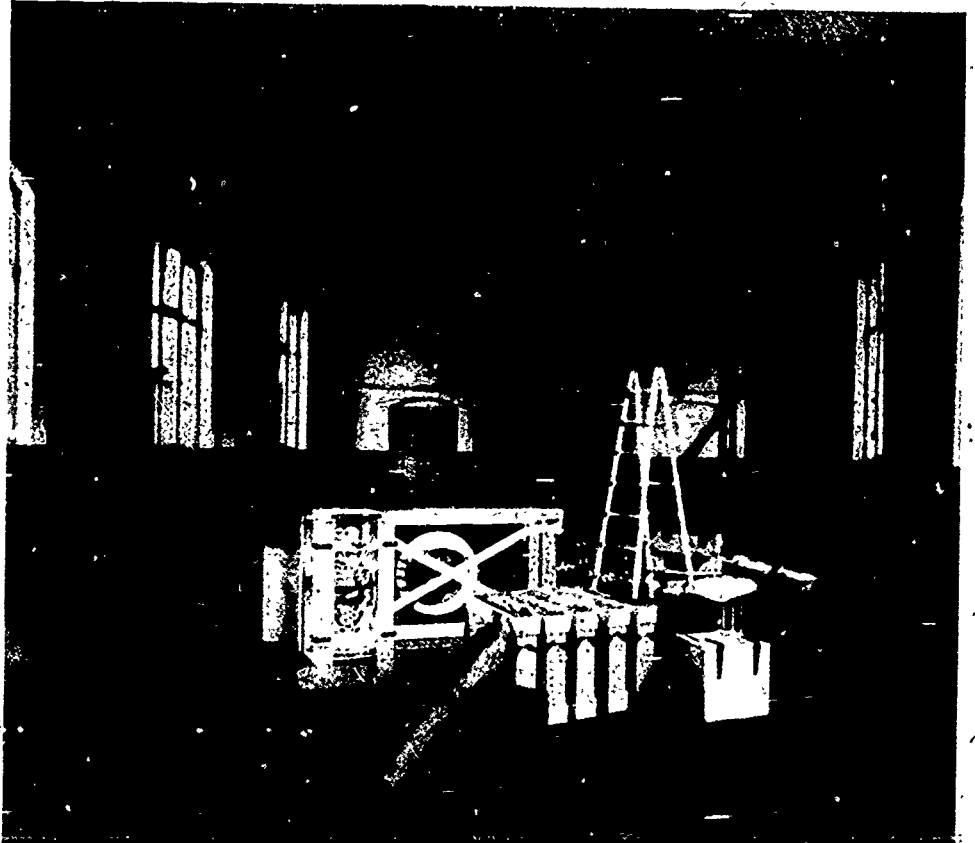



28c

28d

(d) A section of a large exhibition on the theme 'The mystery of arthritis and rheumatism'. Edge-lighted plastic carvings illustrate and interpret X-ray photographs shown below. The stands may be used for other exhibitions as the panels can be changed easily. (Photo. Cleveland Health Museum, Cleveland, Ohio)

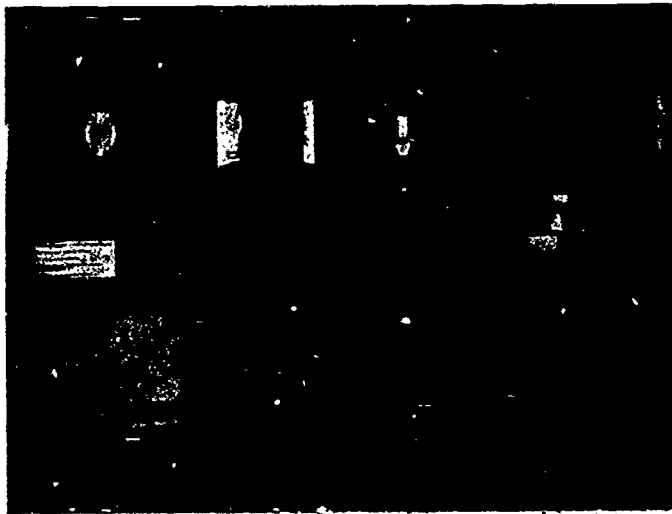



29. A temporary exhibition on the theme Man against Nature. (a) The result of improper agricultural practice and overpopulation. (b) Efforts at conservation through the establishment of national parks and reserves. (c) Species of animals which have become extinct during the historic period. (Photos: Muséum d'Histoire Naturelle, Paris)

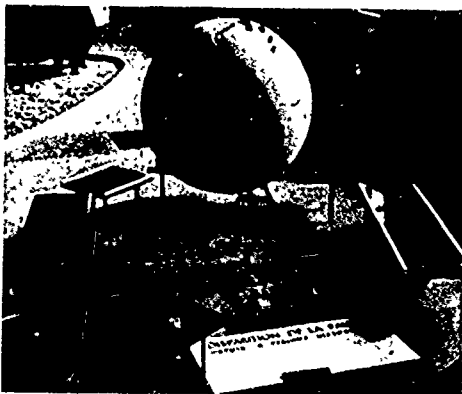

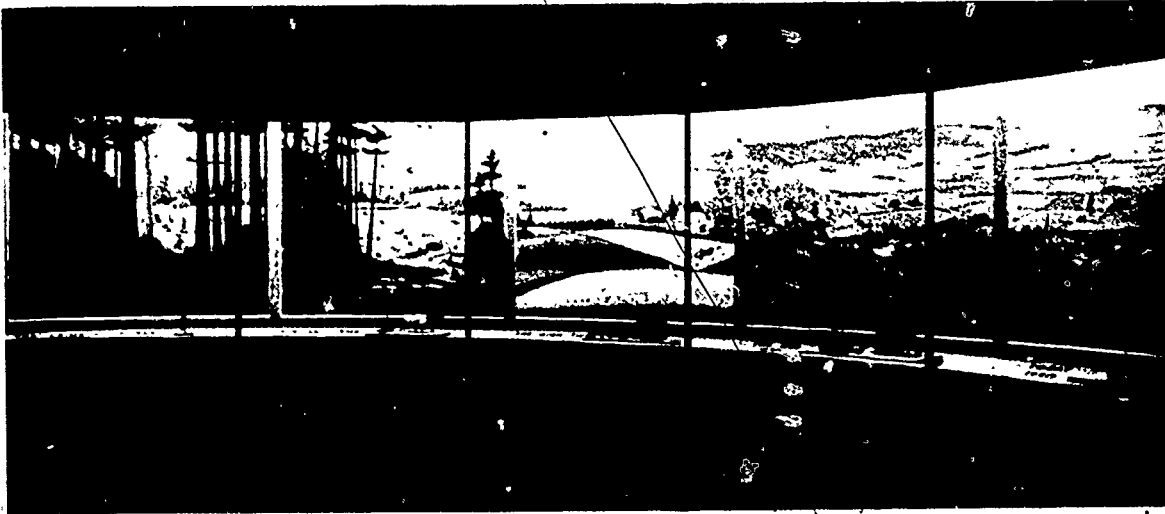

304

304, 306. A series of miniature dioramas showing the sequence of events which affected the ecology of a valley in New York State. The first shows the primeval forest with just a few clearings opened by the Indians, the second, the coming of the European settlers, then the gradual over exploitation of the land, and the eventual recovery following modern conservation methods. (c) Detail showing the 'ebb' in settlement where much of the land was eroded, top soil lost, and the abandonment of marginal lands by settlers moving to the West. (Man and the Land, American Museum of Natural History, New York. See *Museum*, 1952, Vol. V, No. 2)

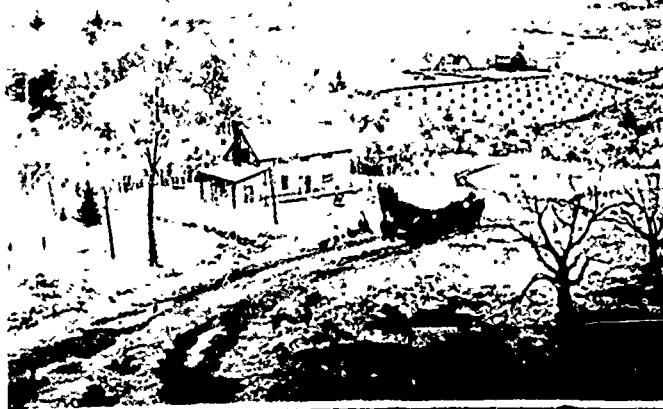

THE EBB
1870



306

316

31a

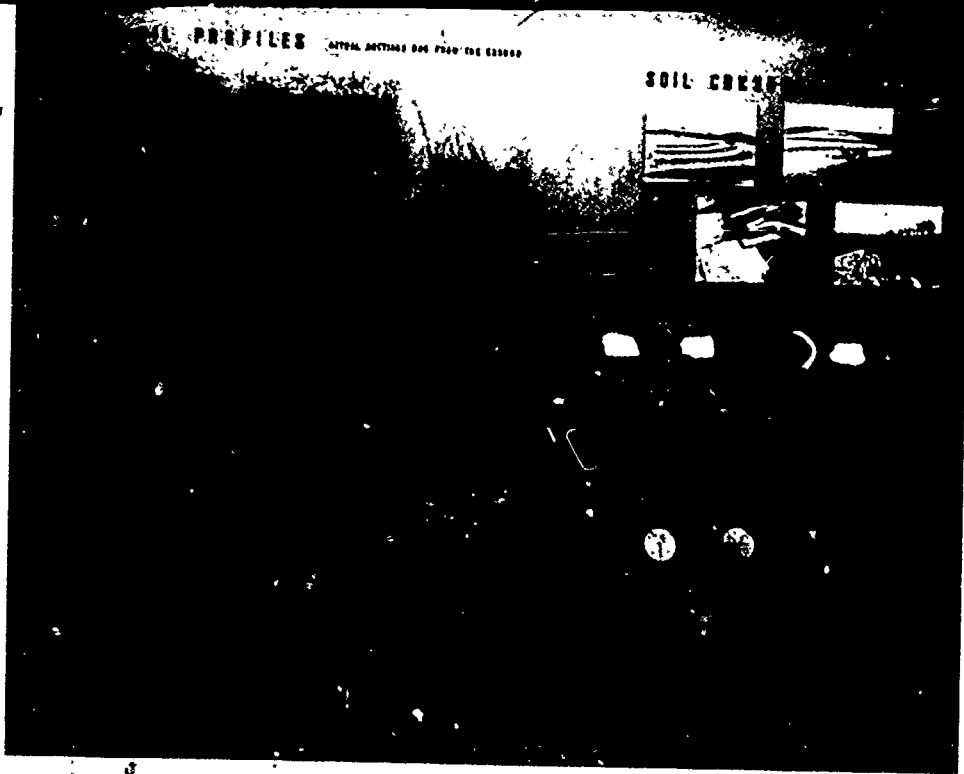

31b

Fertilizers in the Soil

NITROGEN-FIXING BACTERIA

ERIC
Full Text Provided by ERIC

31a, 31b. (a) An exhibition showing soil profiles found in different sections of New York State. Left: stratified sands and clays deposited by water; centre: glacial till; right: alluvial soil. Photographs show soil conservation practices such as strip cropping and contour ploughing. Samples of rocks which form the soil are shown together with different types of soil. (b) An exhibition demonstrating the use of different types of fertilizer. The red clover plant is taken as an example of the use of plants which harbour nitrogen-fixing bacteria, photographs explain the sequence of events. In the foreground the difference between untreated plants and plants which received fertilizer is clearly demonstrated. (Photos: American Museum of Natural History, New York)

32a, 32b, 32c. Three examples of 'suitcase' exhibits. (a) Palaeolithic and Neolithic cultural periods in Wales. The hinged covers protect the glass front of the case and have been used to mount illustrations showing the use of the flint and stone implements. (b) The manufacture of pottery using the wheel. Note a model of the wheel (lower left) and a full-size glazed pitcher (right). (c) The parts of the wheat grain, common uses of wheat and a model of an enlarged grain. In the foreground, the sequence in the preparation of the model. (Photos, Museums Schools Service of the National Museum of Wales, Cardiff)

32a

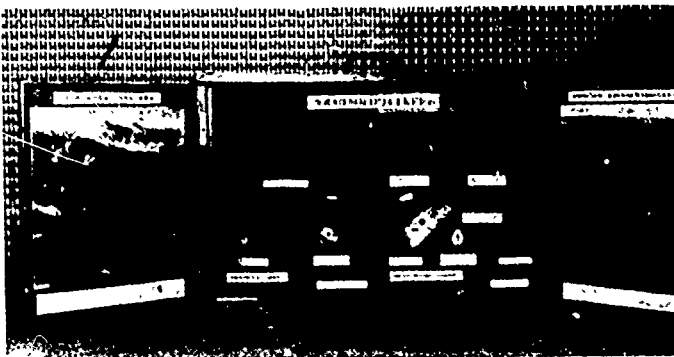

32b



32c

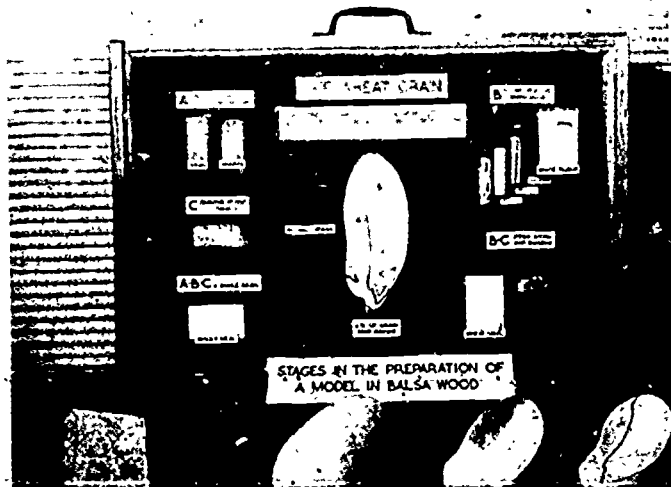

33a

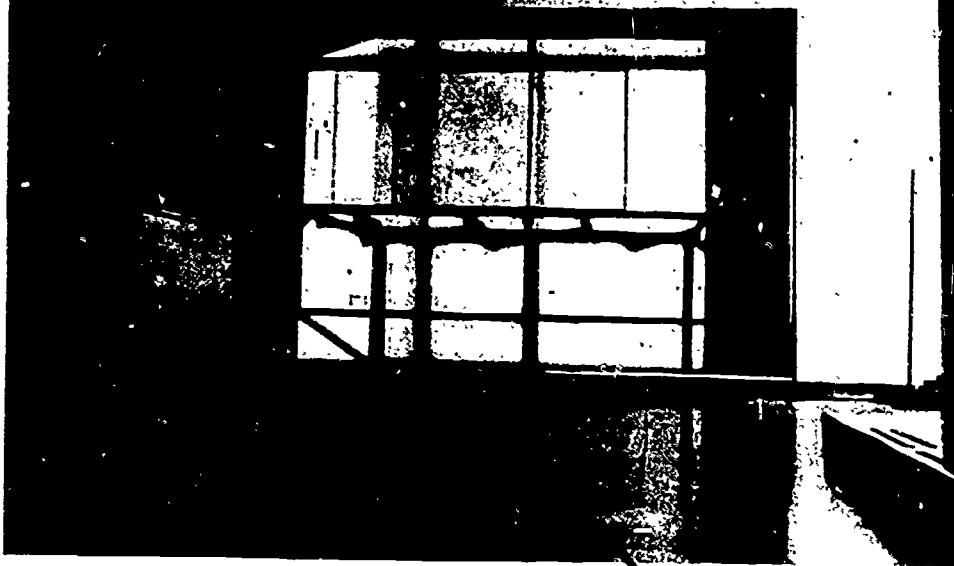

33a, 33b. (a) Framework of a wall-case made of prefabricated parts. The frame is easily assembled and dismantled; it is equipped with patented nuts which are held in place with springs so that the bolts can be easily inserted and tightened. (Photo: Unistrut Products, Wayne, Michigan) (b) Light industrial scaf-

folding was used to prepare this exhibition. Panels are set in place for the exhibition of photographs of African fauna. The scaffolding and panels can be used again for other exhibitions. (Photo: Muséum d'Histoire Naturelle, Paris)

33b



34a



34a, 34b, 34c. Trailer-type mobile museums.
(a) Mobile unit developed for the National Museum in Warsaw. This circulated the exhibition of Mickiewicz-Pushkin, 1949. The top of the trailer is designed to admit natural light.
(b) Trailer unit of the Virginia Museum of Fine Arts, Richmond, Virginia. Note the use of vertical panels set alongside the trailer with explanatory material, sheltered by a plastic awning.
(c) Interior view of the Richmond trailer unit. Exhibition of paintings in which only artificial light from ceiling fixtures is used.

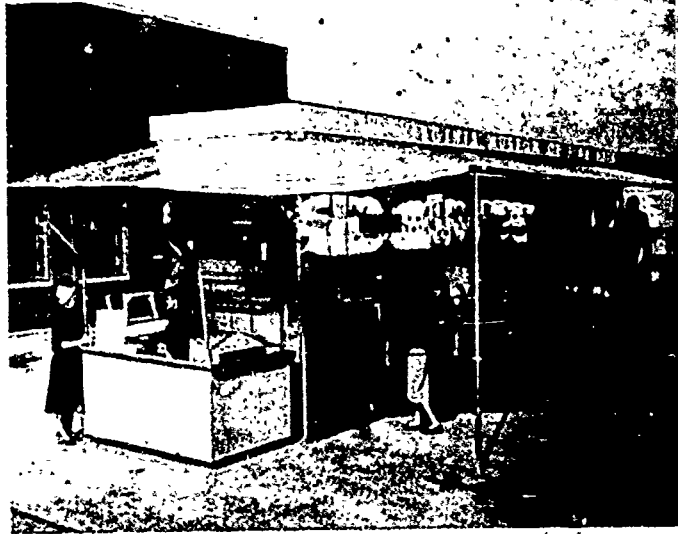

34b

34c



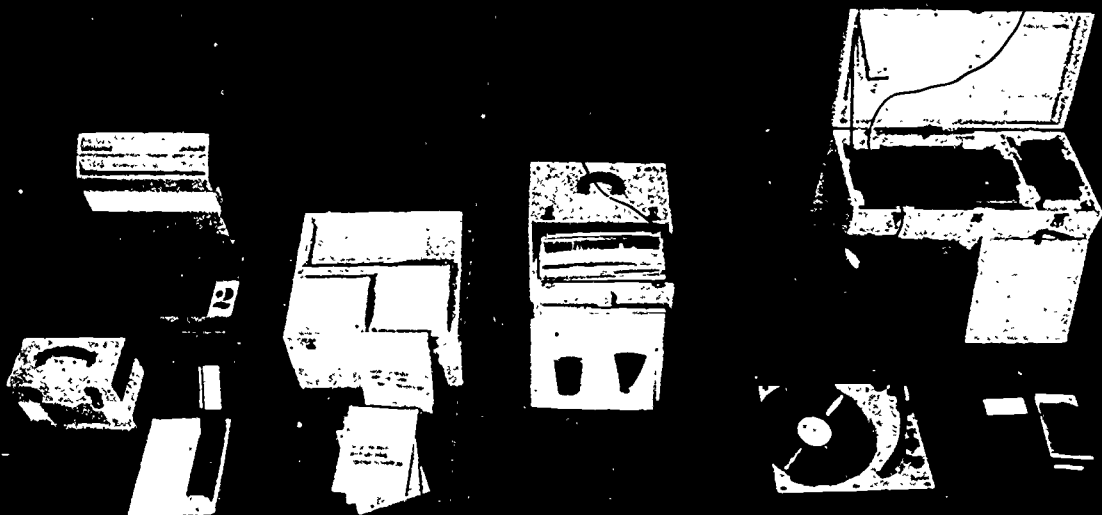

35. Types of educational material prepared and circulated by the Museum of Modern Art, New York. Slide projector; set of slides and printed talks, portfolio of photographic enlargements; classroom booklet of instruction, *How to Make Pottery and Ceramic Sculpture*, exhibition of enlarged photographs of pottery forms, set containing slides, lecture on a record with player and loudspeaker.

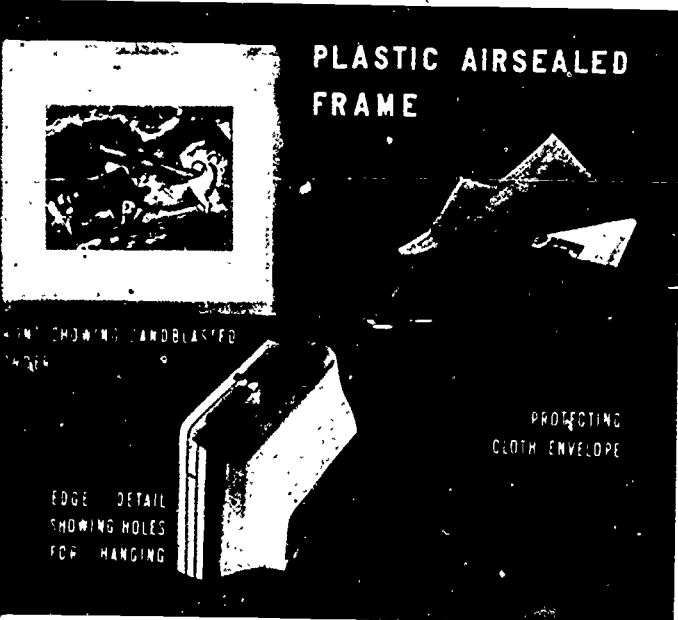

36. A moulded plastic frame designed at the Walker Art Centre, Minneapolis, to enclose watercolours in air-sealed 'envelopes' for a travelling exhibition sent to South America.



37a

37a, 37b. (a) Small cut-out forms simulate figures and show how the material was worn. Panels help to unify the display of a variety of small objects. (Photo: Museum of Modern Art, New York) (b) Display cases and stands for the Sophie Fedorovitch Memorial Exhibition, 1955. (Photo: Victoria and Albert Museum, London)

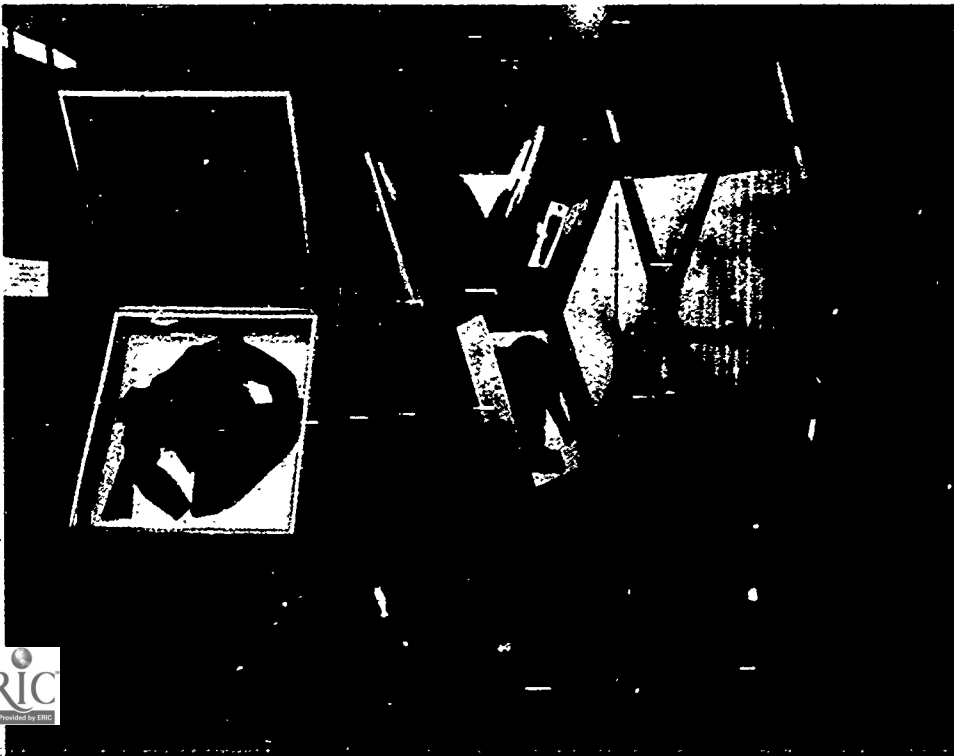

37b

38a



38b



38a, 38b. (a) A traveling exhibition of household objects ("Useful Objects") prepared by the Museum of Modern Art, New York. The tables and supporting frames are standardized to facilitate packing, assembly and disassembly, (b) An exhibition for schools, Machine Art, prepared by the Educational Program of the Museum of Modern Art, New York. Some objects are fixed to the background panel, others may be removed for shipping. The transparent covering is made of plastic (plexiglass) which can be easily inserted or removed through grooves at the sides of the case.

39a, 39b, 39c, 39d, 39e, 39f. Self-contained travelling exhibitions. (a) An exhibition organized for the symposium on arid zones field at Unesco during May 1960. The light angled tubes forming the support are inexpensive to manufacture and can be easily stored or shipped. (Photo: Unesco) (b) Man Measuring the World, a science exhibition prepared by Unesco and circulated among a number of countries. The bent tube framework supports vertical explanatory panels, instruments are shown on a bench. (Photo: Unesco)



39a

39b

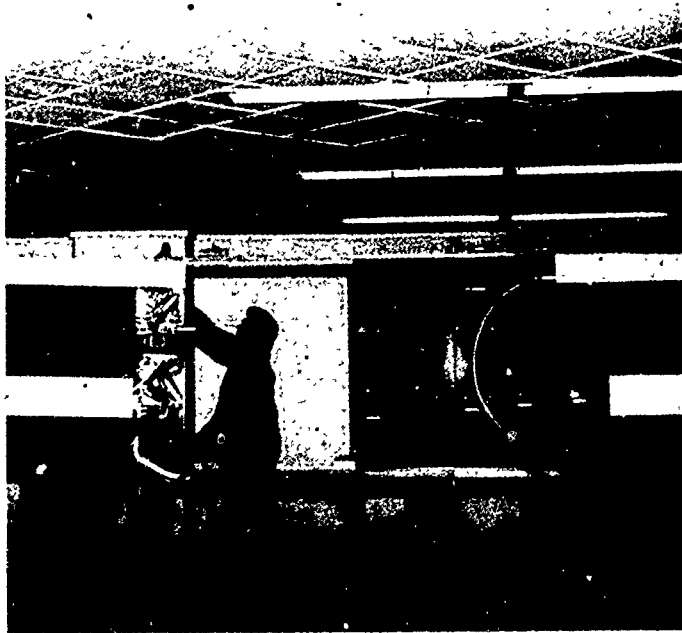

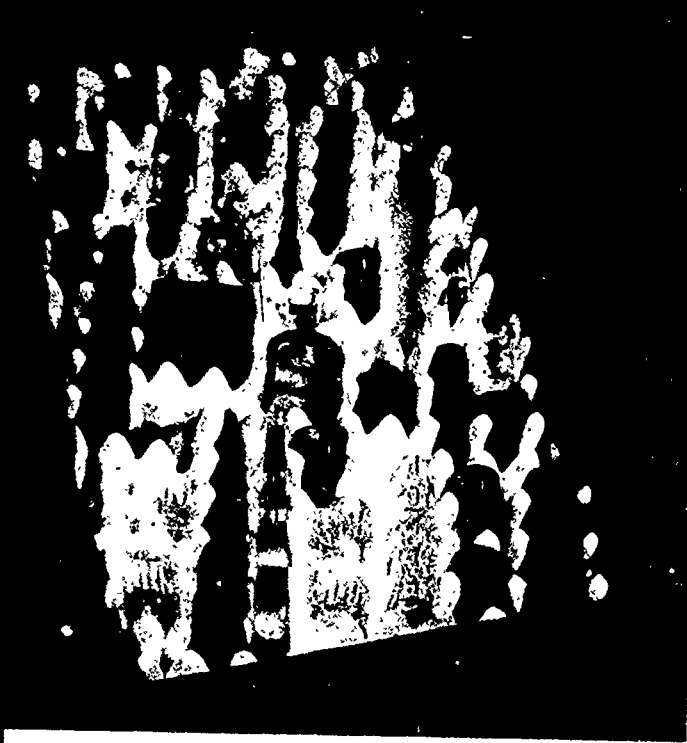

(c) A cardboard carton lined with plastic foam in which glass articles can be nested. Several cartons are then placed in shelved packing cases made of wood. (Photo. Corning Museum of Glass, Corning Glass Center, Corning, New York) (d) Pyramidal cases made of plastic can be joined together in a series of different combinations. A rear view of an assembled unit being loaded on a truck. (Photo. Corning Museum of Glass)

39c

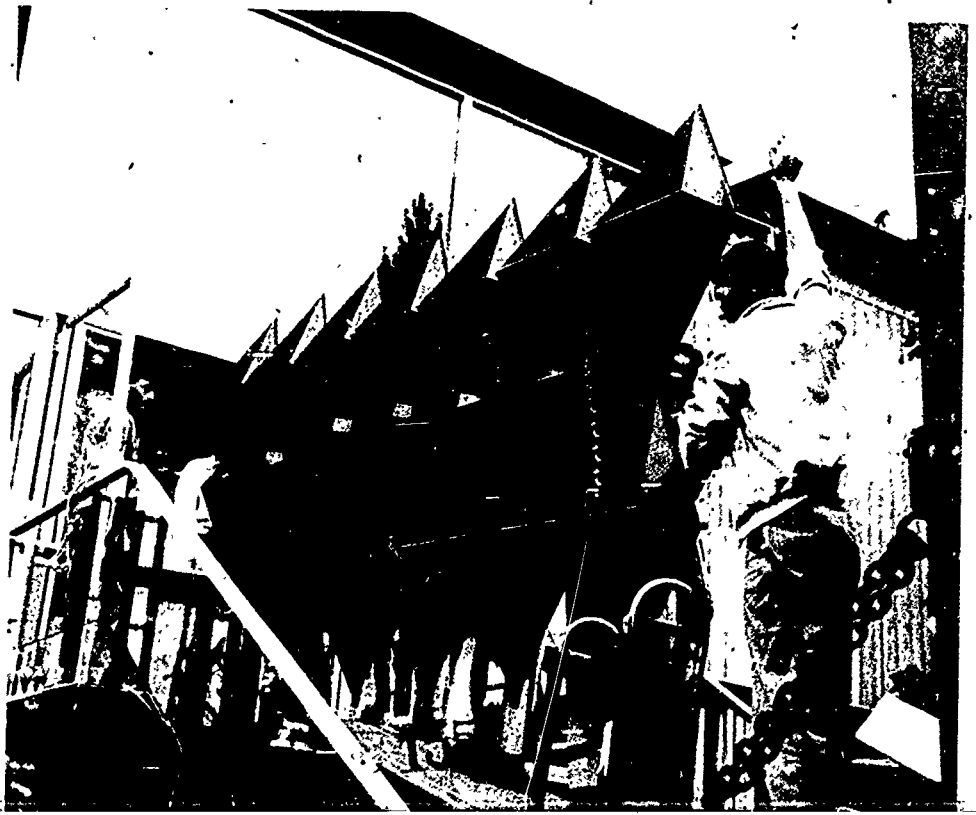

39d



(e). A fully installed display. Each pyramidal unit is independent and has its own fluorescent lighting system and a label printed in white letters on a black background. (Photo: Corning Museum of Glass)

(f) A Neighbourhood Planning Teaching Model. The case contains a number of units for working out problems and solutions as well as texts and other illustrative material. (Photo: Museum of Modern Art, New York)

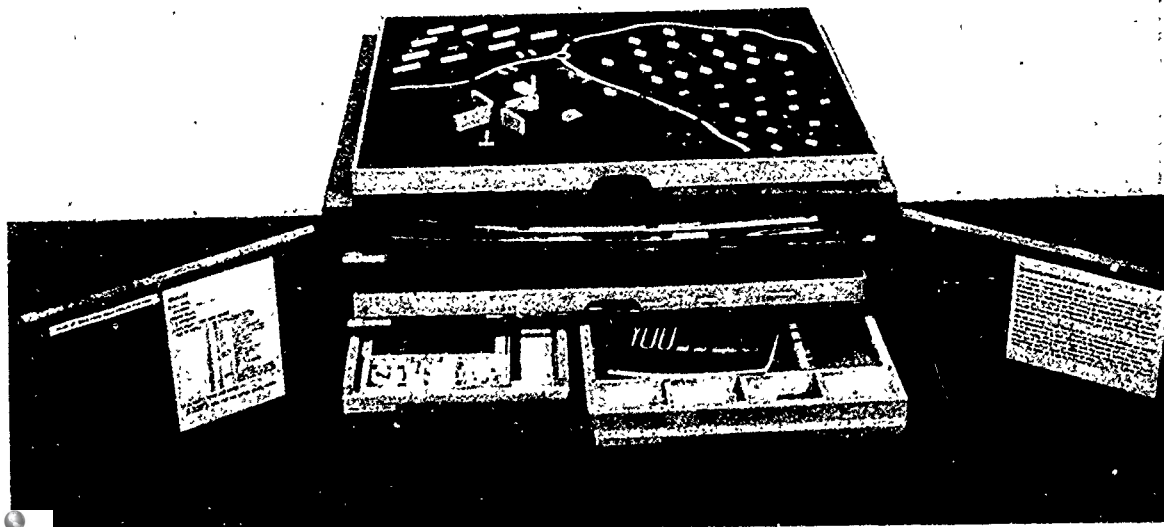

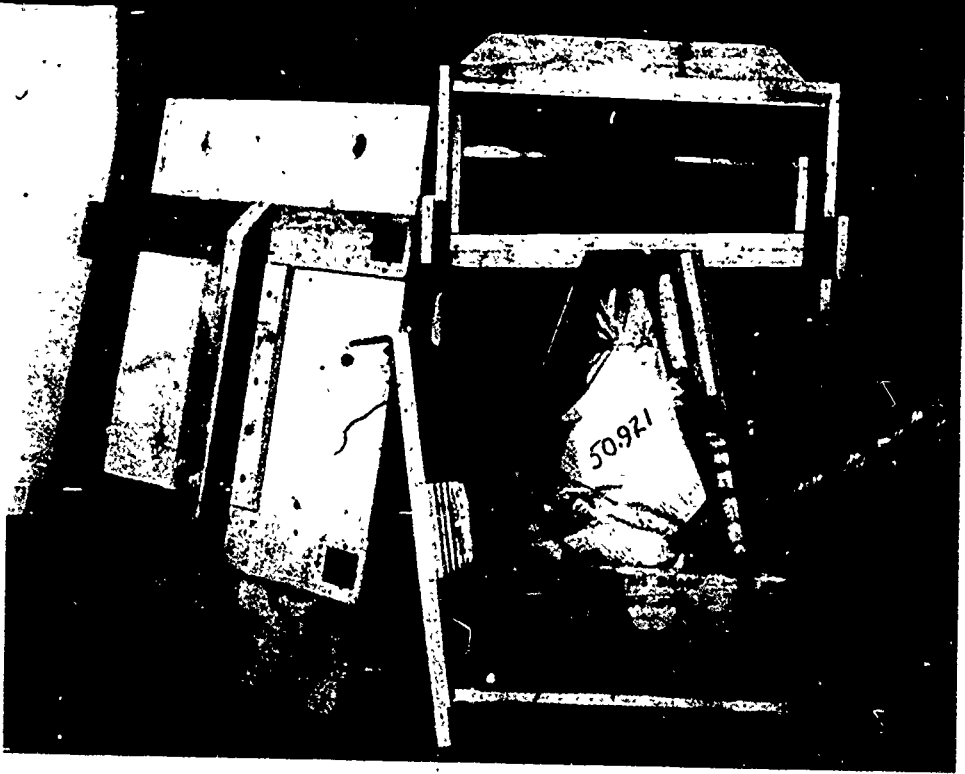

40. Case containing sculpture. Note 'fins' placed on the top and the sides of the case so that packers have to place it upright. The photograph also shows the metal plates to receive bolts when the case is closed for shipping. (Photo: Museum of Modern Art, New York)

41. Packing box designed by the Addison Gallery of American Art, Andover, Massachusetts. Paintings fit into individual trays or racks which have been padded with felt. This eliminates the need for removable packing material.

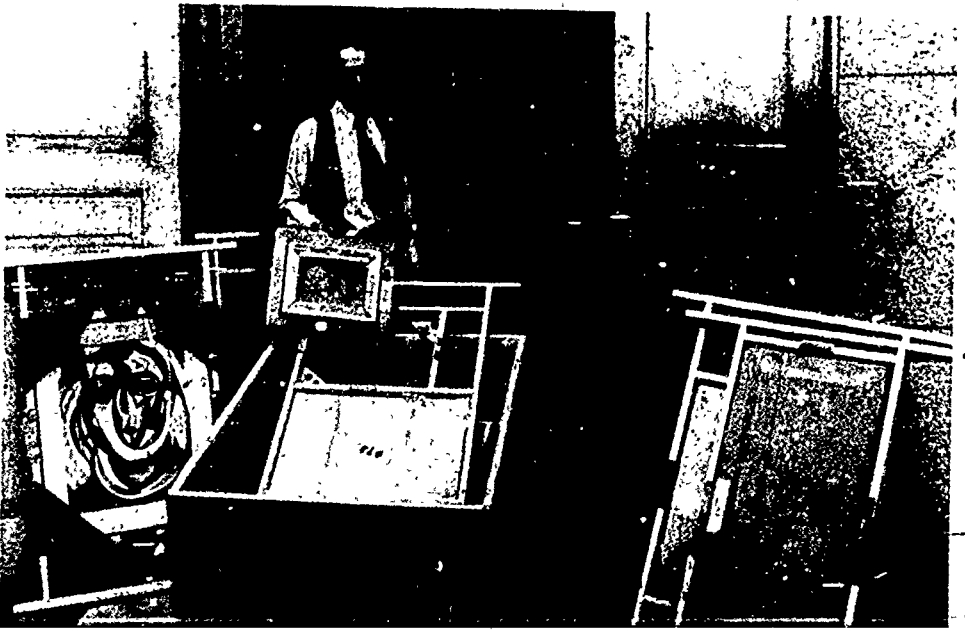

42. Case for uniformly framed and matted watercolours which have been placed in envelopes or inner cases (see Fig. 22). Frames, cases and boxes can often be re-used for other similar exhibitions prepared for tours. Smaller pictures are fitted into the case by filling in open spaces with excelsior pads wrapped with paper. Large pads, shown on the bottom, are placed on top of the open-ended inner case to prevent them from slipping during transit. (Museum of Modern Art, New York)



43. A shipping case designed to carry paintings which could be fitted in only one way, by sliding them into appropriate grooves padded with foam rubber (see also Fig. 23). (Museum of Modern Art, New York)

42

43

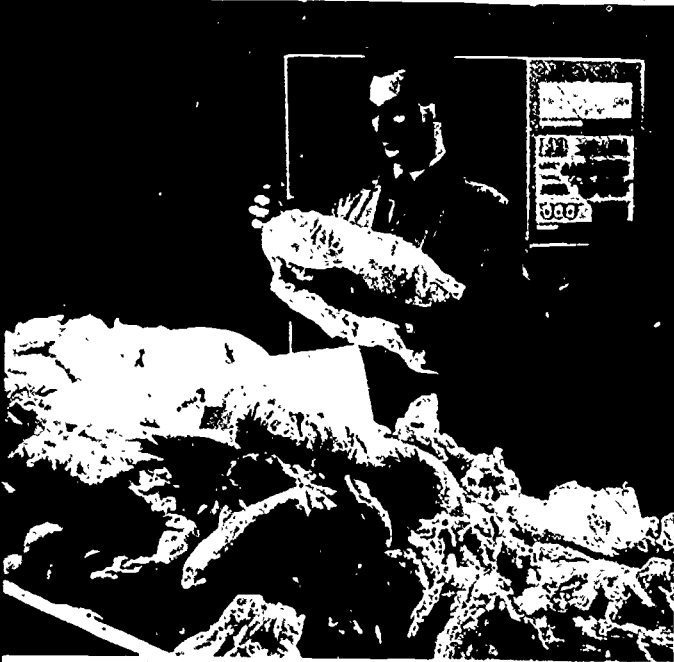

44a



44b

44a, 44b, 44c, 44d, 44e. Preparations for a travelling exhibition, English Silver 1660-1910, at the Victoria and Albert Museum, London. (a) Packing material is being rolled into wads made of sheets of small hand paper faced with tissue. (b) The larger pieces have been placed in the bottom of the case and smaller objects are now being nested in the larger ones. Note also the padded waxed paper lining the container.

6
(c) Dismantling one of the cases used for travelling exhibitions. This case packs into eight separate flat pieces. (d) Loading the packing cases into one of the two vans of the museum. (e) Assembling the exhibition. The case shown is complete except for the final side-panel of glass. Within the case a separate compartment has been set into place to show off the pieces effectively. The entire exhibition included six of these units. (Photos: Crown Copyright, 1961)

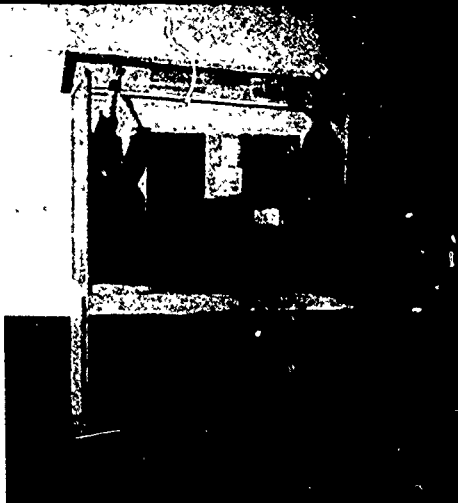

44c



44d

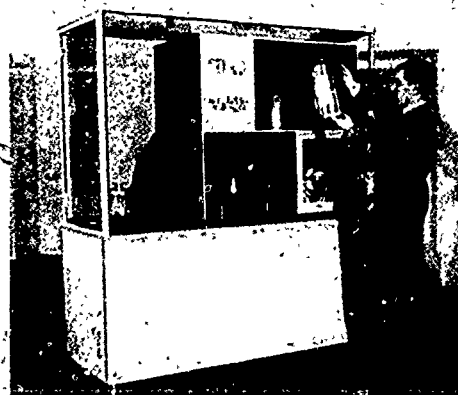

44e

45. The small piece of sculpture shown on the left is to be put in the inner wooden box and held in place by two padded braces. It will then be placed in its own excelsior padded compartment. The sculpture at the right is shown in its bed of excelsior. When packed for shipment it would be wrapped in the cloth case prior to being placed in the excelsior. (Photo. Museum of Modern Art, New York)

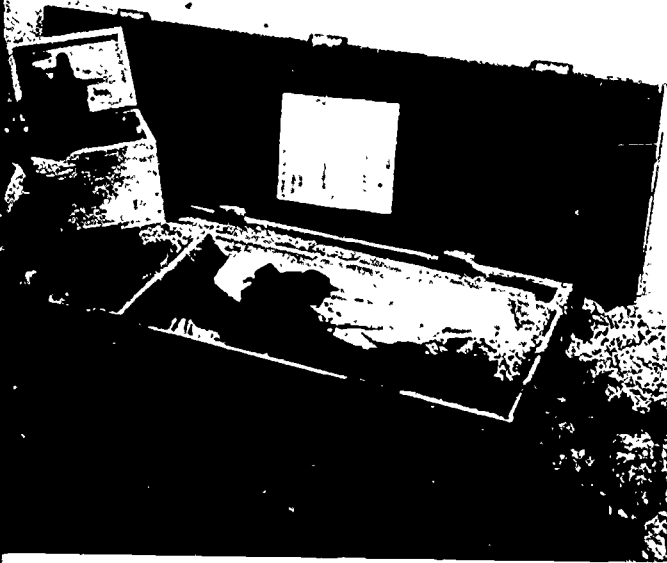

45



46

46. A large crate containing several inner boxes of wood. The small boxes are lined with foam rubber pads and braces have been fitted to hold the sculpture in place. The inner boxes are then "floated" in tightly packed excelsior. Exhibitors are requested not to remove the inner cases from the packing box. (Photo. Museum of Modern Art, New York)

47a, 47b. (a) Note how the wooden braces fit around the object. The braces are attached to the walls of the packing case by screws through right-angle metal plates. Directions to packers are written on the braces with indelible ink. (b) Container for a large bronze figure: Felt pads line all braces wherever they come into contact with the sculpture and are also placed at the top and the base. Note markings on box to guide shippers and packers and the fins placed on the sides and cover. The bolts encircled in ink at the sides are those which fasten the braces holding the figure to the sides of the case. (Photos: Museum of Modern Art, New York)

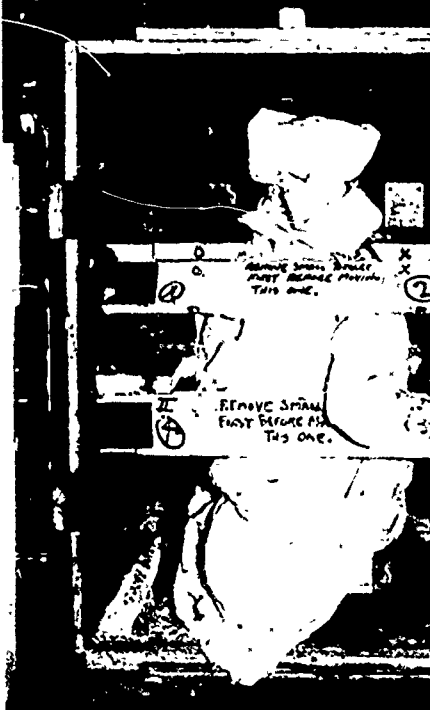

47a

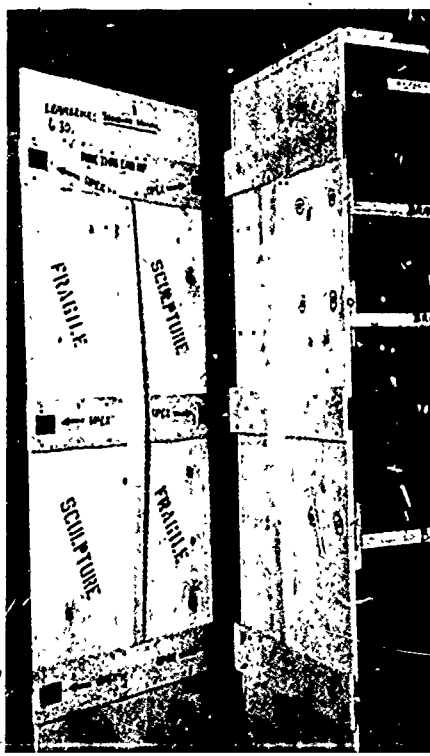

47b

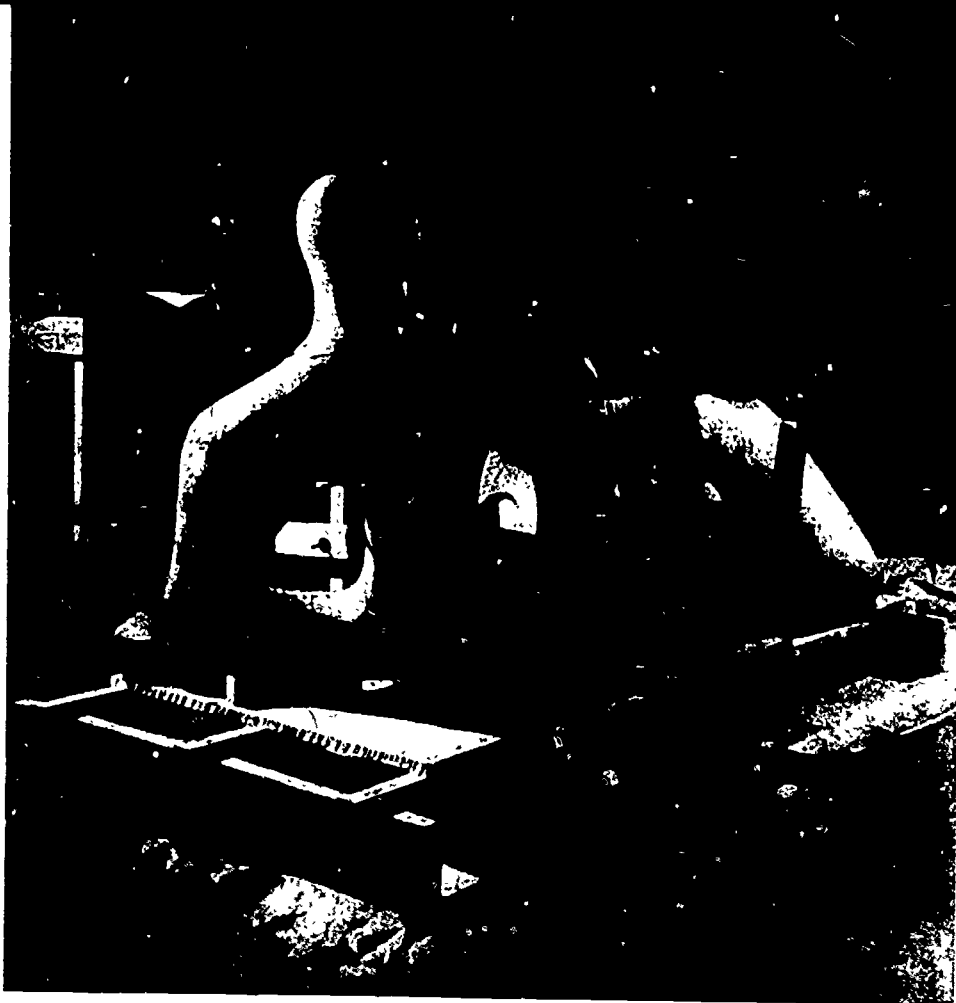

48a

48a, 48b, 48c. A large sculpture by Henry Moore being packed for overseas shipment. (a) Padded cross-bars hold the figure firmly in place; note that all braces are bolted, not nailed, into place. (b) Detail showing padding on the blocks which have been bolted into place to brace the elbow of the reclining figure. (c) Method of framing and bracing for the entire case. The waterproof lining has been torn away to show the details of the cross-bracing used in the case. (Photos: San Francisco Museum of Art, San Francisco)

48b



48c

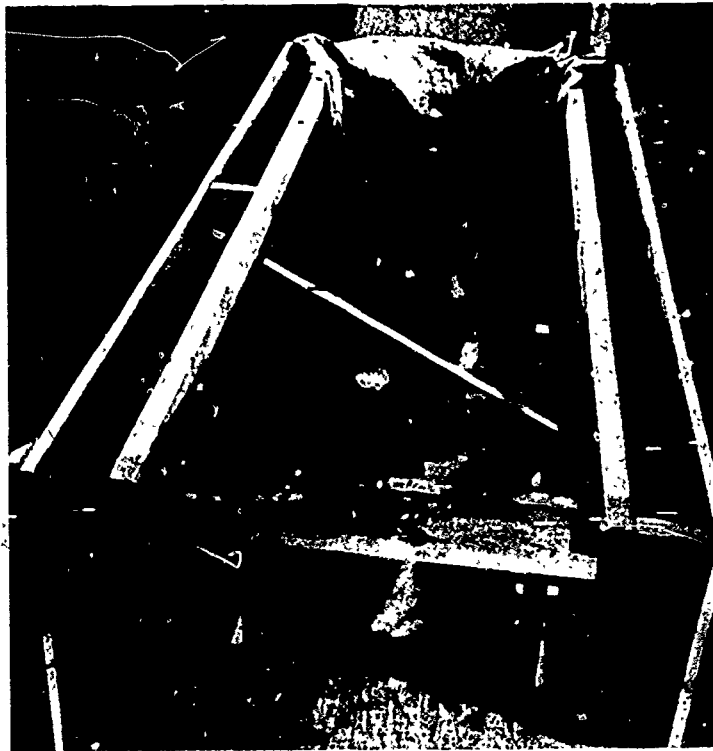

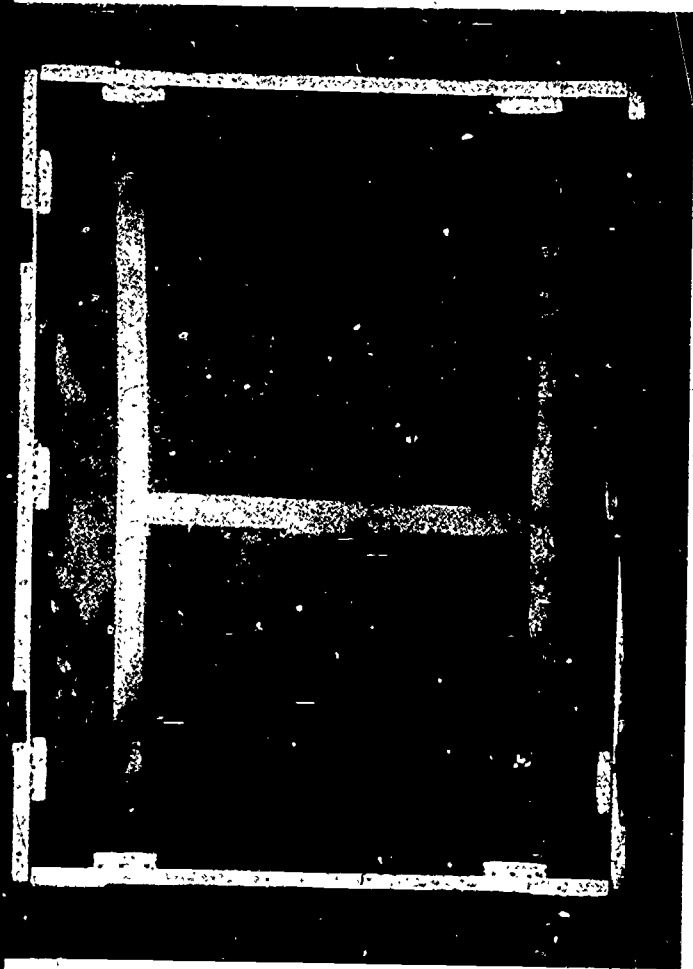

49

49. Package of panels of enlarged photographs which have been wrapped together and sealed with gummed tape. The blocks placed at intervals around the package are cloth-wrapped pads of foam to cushion the package while it is in transit. (Photo: Museum of Modern Art, New York)

[A. 1828] \$ (1828) (1828); 16F