

CYCLOSIZER

MODEL M16



Operation and Maintenance Manual

Manufactured by MARC Technologies Pty Ltd

CYCLOSIZER CALIBRATION CERTIFICATE

Client:			
Model:	M16		
Serial Number:	MARC0xx	Year of Manufacture	
MARC Ref #:		Date:	

The Cyclosizer MARC 0XX was calibrated on _____, 2015 and found to have the following separation sizes under the standard conditions set out in Section 2.3 of the manual.

Water flowrate: 11.6 L/min

Water temperature: °C

Particle density: 2.65

Elutriation time: infinite

Cyclone 1 = microns

Cyclone 2 = microns

Cyclone 3 = microns

Cyclone 4 = microns

Cyclone 5 = microns

Corrections to these separation sizes can be made by applying the factors set out in Figures 8 to 11 in the manual.

This Cyclosizer machine was manufactured by MARC Technologies. Sales and parts enquiries can be made directly through MARC Technologies or their appointed agent. Please contact MARC for a list of appointed agents. Resellers are not appointed agents.

Not many changes have been made to the Cyclosizer design over the years although model numbers have changed to reflect minor changes.

The latest revision of the Cyclosizer is to an M16 model, which reflects changes such as the knob re-design and electrical component improvements.

Request Spare Parts or Technical Assistance at:

Email: info@marctech.com.au

Phone: +61 (0)8 9232 0430

CYCLOSIZER INSTRUCTION MANUAL

PARTICLE SIZE ANALYSIS IN THE SUB-SIEVE RANGE

Preliminary Printing – September 1964

First Revision – June 1965

Second Revision – August 1981

Third Revision – October 1997

Fourth Revision – August 2012

Fifth Revision – July 2014

MARC Technologies Pty Ltd

109 Bannister Road

Canning Vale WA 6155

Australia



Credit is given to Warman International Ltd for the original contents of this manual.

Preface to Fifth Revision

At the time of revising this manual, the 16th model of the Cyclosizer M16 is in production. Since 1964 there have been a number of minor component changes brought about by various suppliers revising production items. These component changes have periodically necessitated the designation of a new model type in order that the instrument can be identified for spare parts replacement. The principle of operation of the Cyclosizer remains unchanged.

In the period since the first revision of the instruction manual in 1965 Australia has officially changed to metric units of measurement and this along with the component variation constitute the major changes to the manual. Owners with models prior to M16 can still use the current manual for operating instructions but should take care to quote their model number when ordering spare parts.

Contents

CYCLOSIZER CALIBRATION CERTIFICATE	3
Preface to Fifth Revision	9
Preliminary Note	13
Section 1: Introduction to Sub-Sieve Sizing	15
1.1 Sedimentation and Elutriation	15
1.2 Concept of Stokes' Equivalent Diameter	15
Section 2: Principle of the Cyclosizer	17
2.1 Limiting Particle Separation Size and Effective Particle Separation Size	17
2.2 Design of the Cyclones	21
2.3 Operating Variables and Correction Factors	23
2.4 Calibration and Accuracy of Sizing	27
Section 3: General Description and Method of Operation	31
Section 4: Sample Preparation	33
4.1 Sub-Division of the Gross Sample	33
4.2 Preparation of the Test Sample	34
Section 5: Particle Size Analysis	35
5.1 Installation Instructions	35
5.2 Commissioning Instructions	35
5.3 Test Procedure	36
5.4 Calculations	39
Cyclosizer Results Sheet	42
Sample of Completed Cyclosizer Results Sheet	43
Figure 8: Temperature Correction Factor f_1 Chart	44
Figure 9: Specific Gravity Correction Factor f_2 Chart	46
Figure 10: Flowrate Correction Factor f_3 Chart	47
Figure 11: Time Correction Factor f_4 Chart	48
Section 6: Mechanical Features, Care and Maintenance	49
6.1 Water Tank and Pump	49
6.2 Rotameter	49
6.3 Pressure Gauge	49
6.4 Control Valve and Sample Container Assembly	50
6.5 Cyclone Assembly	50
6.6 Control Panel and Electrical Features	50
6.7 Drainage System	51
6.8 Dial Thermometer	51
Drawing: Figure 12 - Control Valve and Sample Container Assemblies	52
Drawing: Figure 13 - Cyclone Assembly Details	53
Recommended Spare Parts	54

Preliminary Note

The subject matter of this Instruction Manual is presented in six sections: Sections 1 and 2 are a theoretical introduction to sub-sieve sizing and the principle of the Cyclosizer whilst Sections 3 to 6 presents the practical approach to the operation of the apparatus.

For your initial work with the Cyclosizer a study of the material presented in Sections 1 and 2 is not necessary and you may therefore find it convenient to commence your detailed reading at Section 3. After you have obtained some experience with the apparatus and are familiar with the operating and calculating procedures you may then return and study the first two sections in detail.

For those to whom sub-sieve sizing is a new topic, we point out that this manual is but a brief introduction and we therefore recommend that you study some of the literature available on this subject.

If, in using the Cyclosizer, you have any queries or points for discussion, then we invite you to email the following address and we will be pleased to discuss the matter: **info@marctech.com.au**

The design and operating characteristics of the hydraulic cyclone elutriator were first described by D F Kelsall and J C H McAdam for the Commonwealth Scientific and Industrial Research Organisation. [Trans Inst Chem Eng 41,84 (1663)]. In preparing this manual, we have drawn on our own experience and also that of Kelsall and McAdam. Grateful acknowledgment is made for this assistance.

Section 1: Introduction to Sub-Sieve Sizing

1.1 Sedimentation and Elutriation

For particle size analysis, elutriation and sedimentation techniques are well-known procedures designed to give a sizing distribution on the basis of hydrodynamic similarity. This means simply that all particles which the same specific gravity and the same free-falling velocity in a given fluid are considered as being the same *size*, irrespective of variations in physical dimensions.

In sedimentation techniques, the material to be sized is dispersed in a fluid and allowed to settle under carefully controlled conditions. The weight of sediment or the specific gravity of the suspension is measured by various means as a function of time, and the two variables are then calculated to give a particle size distribution curve. In particle size analysis by sedimentation, separation into sized fractions is not practical.

In elutriation techniques, samples are sized by allowing the dispersed material to settle against a rising fluid velocity. By varying the rising velocity, fractions may be collected within certain size ranges, and different forms of elutriation apparatus are designed for this purpose. The principle of elutriation depends on a balance between the gravitational forces on the particles and the drag forces due to the differential velocity between particle and fluid. Since the particles are in the sub-sieve range and under the influence of one *g* only, the forces are very small and difficult to control for reproducible results.

The Cyclosizer is an elutriator in so far as it separates a sample into specific size fractions by a technique which depends on the forces produced by the relative velocities of the particle and the elutriating fluid. It differs from conventional elutriation, however, in that the elutriating action takes place in a hydraulic cyclone where the fluid is spinning and centrifugal forces many times those due to gravity are acting on the particles. In addition, the flow patterns within the cyclone are very stable and changes in ambient conditions are not nearly as critical as in the conventional procedure for elutriation. Also the high shearing forces which are developed in a cyclone overcome any natural tendency for the fine material to flocculate and excellent dispersion of the particles is ensured.

The net result is that for a comparatively short elutriating time, the Cyclosizer is capable of yielding highly reproducible sizing analyses within the sub-sieve range.

1.2 Concept of Stokes' Equivalent Diameter

There are many concepts in use for designating particle size within the sub-sieve range and it is important to be aware of these different concepts when considering one's own work and the results of others. Different methods of particle size analysis assess different size-dependent properties such as physical dimensions, volume, surface area or resistance to motion in a fluid. Invariably the results of these assessments are expressed as a single dimension, the *particle size*, which is usually designated by the symbol *d*. Depending on the shape characteristics and the particle density, the particle size *d* as determined from different size-dependent properties can vary between wide limits. It is only when particles approach spherical proportions and accurate corrections can be made for particle density that the different concepts have a definite relationship.

The Cyclosizer, being an elutriator, separates on the basis of resistance to motion in a fluid. This resistance to motion is characterised by the free falling velocity which the particle attains as it is allowed to fall in a fluid under the influence of gravity. For particles within the sub-sieve range, this velocity is described by the well-known Stokes' Equation which states the relationship between the free falling velocity and the diameter of a spherical particle falling under the influence of gravity.

	v	=	$\frac{d^2 g(\sigma - \rho)}{18\eta}$
where	v	=	free falling velocity (cm/sec)
	d	=	particle diameter (cm)
	g	=	acceleration due to gravity (m/s ²)
	σ	=	particle density (g/cm ³)
	ρ	=	fluid density (g/cm ³)
	η	=	fluid viscosity (cp)

Similarly, non-spherical particles will attain an equilibrium free falling velocity, but the attained velocity is dependent on particle shape. Nevertheless, this velocity can be substituted in the Stokes' Equation and the value of d so determined can subsequently be used to characterise the particle. This value of d is referred to as the *Stokes' equivalent spherical diameter*. It is also known as the *Stokes' diameter* or sometimes as the *sedimentation diameter*.

The Cyclosizer collects into a single faction all particles which have a settling rate within a specified range. Therefore, the Stokes' equivalent diameter of all such particles will similarly be within a certain range, providing all have same density. If the density varies between particles, then, to maintain the validity of Stokes' Law, each fraction will have a different size range for each particle density.

The concept of Stokes' equivalent diameter is used exclusively in this manual for describing particle size.

Section 2: Principle of the Cyclosizer

2.1 Limiting Particle Separation Size and Effective Particle Separation Size

The Cyclosizer collects particles into accurately defined size ranges within the bodies and the apex chambers of the five cyclones which form the basis of the Cyclosizer. In order to understand precisely why this occurs and to understand the effect of the operating variables on the sizing analysis, it is necessary to discuss firstly the principle of the hydraulic cyclone as a separate unit.

A typical hydraulic cyclone, illustrated in Figure 1, consists of a short, cylindrical section (the vortex chamber) closed at one end and fitted with an axially mounted overflow pipe (the vortex outlet) protruding into the body of the cyclone. There is a tangential feed opening as shown. A conical section is connected at the other end of the cylinder and terminates in a circular opening at its apex.

Figure 1 Basic Features of the Hydraulic cyclone

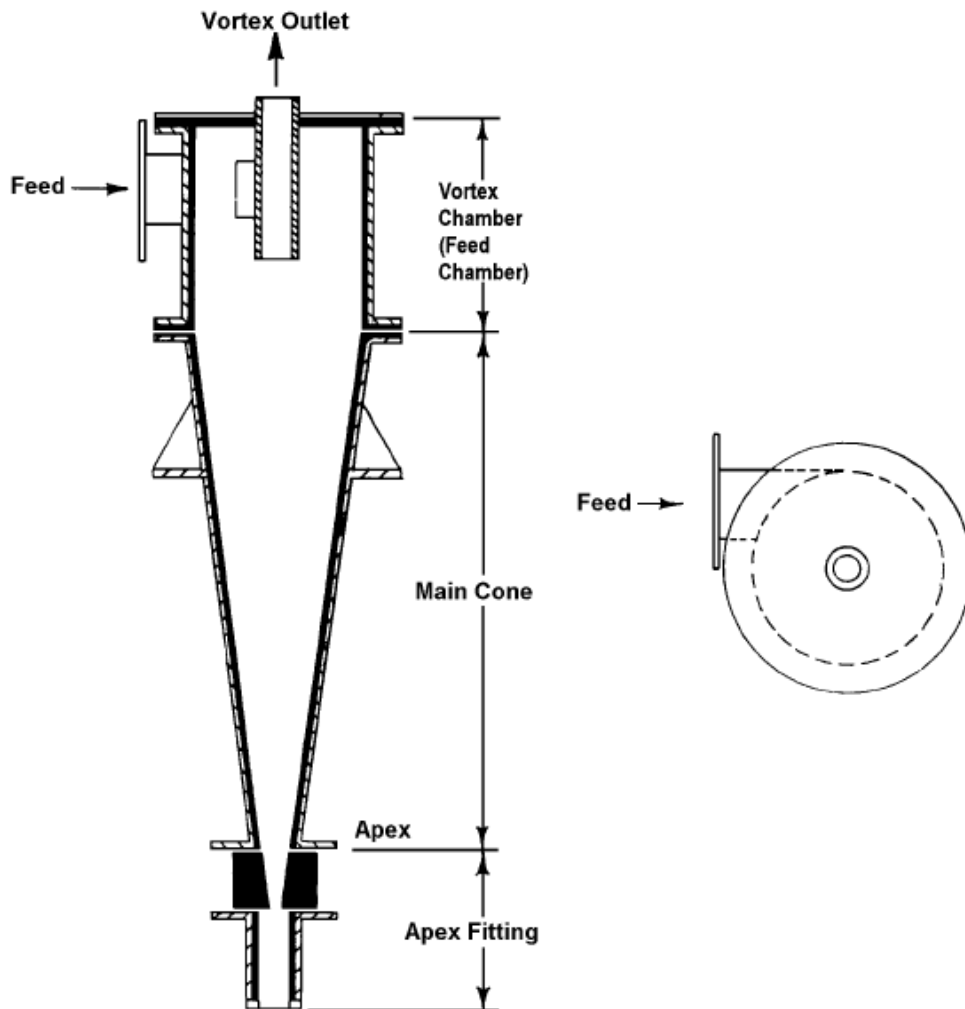

For operation, a suspension of solid particles in a liquid is introduced under pressure through the feed opening. The tangential entry induces the liquid to spin within the cyclone and the design of the apparatus results in a portion of the liquid, together with the faster-settling particles, being discharged through the apex opening. The remainder of the liquid, together with the slower settling particles, is discharged through the vortex outlet.

If a feed material having a normal size distribution and a uniform particle specific gravity is cyclone at low feed density in the manner described above and the results plotted against the axes show in Figure 2, the typical performance curve obtained is shown by Curve 1 of this figure. This curve shows for any particle size, the percentage of that size which reports to the apex opening. Thus, considering the specific points designated by sizes A B C and D there is in the apex product:

100% of the size A solids
80% of the size B solids
40% of the size C solids
30% of the size D solids

If now the apex product is recycled with clean liquid at the same flowrate in a second cycle, the percentage of the various sizes reporting to the apex will be the same in respect to the feed to the second cycle (ie 100, 80, 40 and 30), but in the respect to the original feed, the percentage reporting to the apex will be the second power of the original fraction. That is, in the second cycle, the percentage of the original feed in the apex product is:

100% of size A
64% of size B
16% of size C
9% of size D

The curve for these figures is as shown in curve 2, Figure 2.

Figure 2 – Cyclone Performance Showing the elimination of Undersize with Repeated Cycloning of the Apex Product

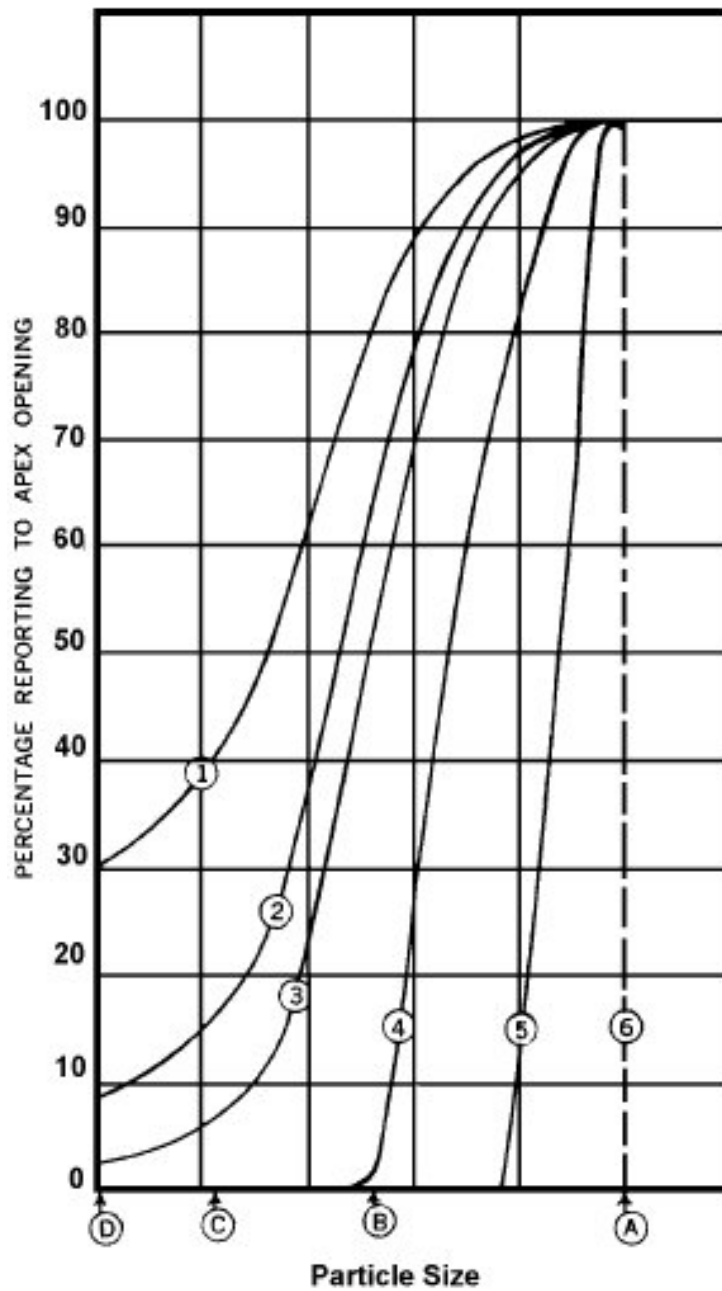

- CURVE ① NUMBER OF CYCLES = 1
- CURVE ② NUMBER OF CYCLES = 2
- CURVE ③ NUMBER OF CYCLES = 3
- CURVE ④ NUMBER OF CYCLES = 10
- CURVE ⑤ NUMBER OF CYCLES = 100
- CURVE ⑥ NUMBER OF CYCLES = ∞

Similarly, if a third cycle is taken, the apex product will then theoretically contain in respect to the original feed:

100% of size A
51.2% of size B
6.4% of size C
2.7% of size D

These figures show that with increase in that number of cycles all solids less than size A are being eliminated from the apex product; and if the number of cycles were continued to infinity, only material greater than size A would remain. For constant conditions of flowrate and particle density, particle size A is characteristic of the cyclone dimensions and is termed the *limiting particle separation size* for the cyclone system. This is a concept which is analogous to *sieve aperture* as applied to screening operations.

Definition: the limiting particle separation size of a cyclone system (as described in the foregoing) is the smallest particle that the system will retain after an infinite number of recycle passes of the apex product. In this manual it is designated by "d_i".

If one considers the example quoted in the foregoing, then the figures clearly show that there is a preferential elimination of fine particles in the early cycles. As the number of cycles increase and approach infinity, the sizes retained for the longest time are closest to the limiting separation size. Therefore, providing a certain number of basic cycles are exceeded, the cyclone system can be considered as effectively separating at a size smaller than the limiting separation size and to describe this condition the term *effective particle separation size* is used.

The relationship between these concepts is that the effective particle separation size approaches the limiting particle separation size as the number of cycles approaches infinity.

The above principle has obvious application in the field of size analysis when:

- (i) The geometry of the cyclone is fixed to give a limited particle separation size in a useful range;
- (ii) The cyclone is arranged to give continuous recycle of the apex product;
- (iii) The relationship between the limiting and effective particle separation sizes can be accurately defined in terms of the number of cycles or the time of operation under constant conditions;
- (iv) Water is used as the liquid medium.

These conditions are met in the design of the cyclosizer.

2.2 Design of the Cyclones

In the cyclosizer, conditions for continuous recycle of the apex solids without recourse to external equipment are achieved by the manner of mounting the cyclones (apex vertically up) in conjunction with the closed apex chambers, which give the units a capacity for retained solids.

Figure 3 shows diagrammatically the flow patterns which exist within the cyclosizer cyclones and which are responsible for the continuous recycle effect. The particles to be sized are fed as a water suspension into the cyclones and are centrifuged in the usual manner with the larger moving toward to conical wall upwards, with a portion of the water, to the apex chamber. By suitable choice of apex diameter and chamber dimensions, the particles discharge to the chamber are subjected to vigorous agitation and tend to be carried back into the conical portion of the cyclone where they are re-centrifuged. Particles less than the limiting size for the cyclone have insufficient mass to be influenced by the centrifugal forces present and tend to remain with the water flow leaving the cyclone through the vortex outlet. Particles larger than the limiting size are centrifuged out of the water flow and remain in the body of the cyclone and in the apex chamber. The approach to an infinite number of recycle stages and ideal separation is a function of time.

The geometry of the cyclones defines the limiting particle separation sizes that they will show for a certain flowrate. More specifically, it is the inlet area and the vortex outlet diameter which are the principal controlling factor. For a fixed flowrate, a decrease in the area of the cyclone inlet produces a corresponding increase in inlet velocity and an increase in the centrifugal forces within the cyclone which then retains a smaller particle. Also a decrease in vortex outlet diameter means a cut closer to the axis of the cyclone, an effect which also contributes to the retention of smaller particles.

In the Cyclosizer the cyclones are arranged in series such that the vortex outlet of each unit is the feed for the next in line. There is a successive decrease in the inlet area and vortex outlet diameter of each cyclone in the direction of the flow and, consequently, there is a successive decrease in the limiting particle separation sizes of the cyclones. In a sizing determination, therefore, the coarsest fraction is collected in the No 1 cyclone and the finest fraction in the No 5 cyclone.

Figure 3 – Diagrammatic illustration of the Flow Pattern inside the Cyclosizer Cyclones.

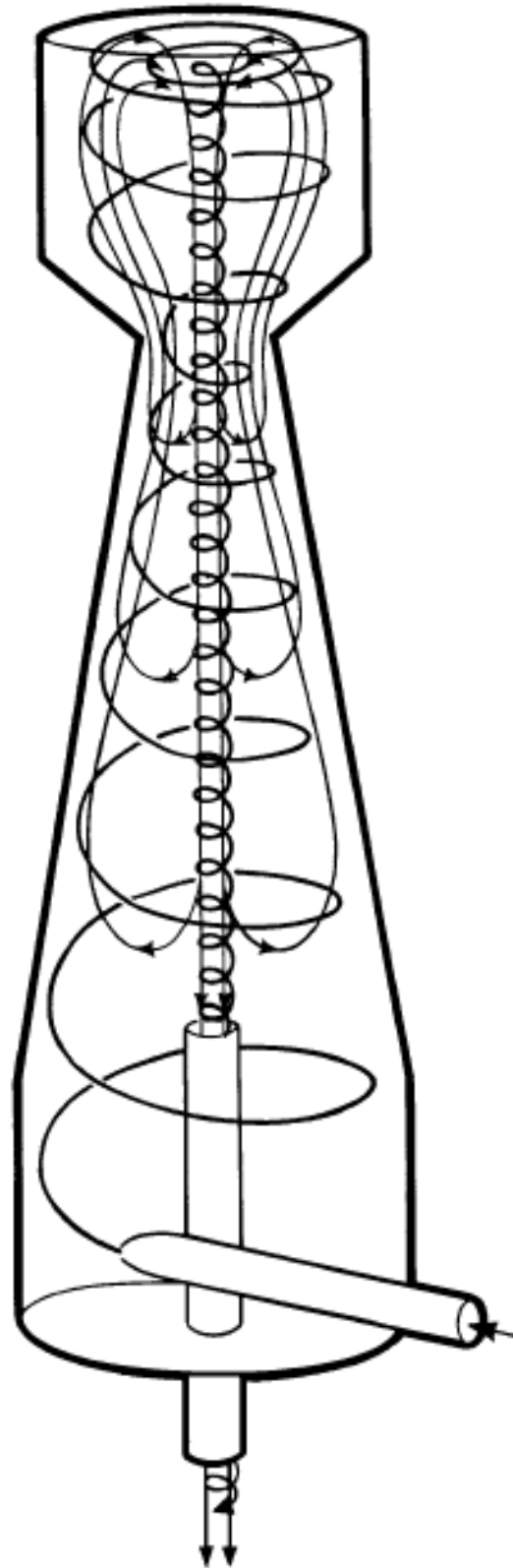

2.3 Operating Variables and Correction Factors

There are four important operating variables which determine the effective particles separation sizes for the five cyclones:

- (i) Water flowrate
- (ii) Water temperature
- (iii) Particle density
- (iv) Time of elutriation

For practical operation, the effect of these variables is well known and the unit may be operated at any combination of the variables within the specified ranges. If the effective separation size of the cyclones at one level of the variables is known, the separation sizes at other levels can be readily calculated.

The cyclosizer is manufactured to have limiting separation sizes similar to those given in Table 1 at the standard values of the operating variables. Before leaving the factory, however, it is tested, calibrated and shown to separate at the sizes quoted on the calibration certificate.

TABLE 1	
Limiting Particle Separation Size at the Standard Conditions.	
Cyclone No	L.P.S.S.
1	44 microns ±2
2	33 microns ±1
3	23 microns ±1
4	15 microns ±1
5	11 microns ±1

The standard values of the variables are:

- (i) Water flowrate: 11.6 litres per minute
- (ii) Water temperature: 20°C
- (iii) Particle density: 2.65 g/cm³
- (iv) Time of elutriation: infinite

To correct for practical operation at other levels of these variables, a set of correction graphs is provided. These graphs give a correction factor for each variable within the specified operating range and for any cyclone the relationship between the specified *limiting* particle separation size and the *effective* separation size is given by:

$$d_e = d_i \cdot f_1 \cdot f_2 \cdot f_3 \cdot f_4$$

Where: d_e = effective particle separation size of a cyclone.

d_i = limiting particle separation size of the same cyclone.

And f_1, f_2, f_3, f_4 are the separate correction factors for temperature, particle density, flowrate and time, respectively.

Refer to Section 5.4 for instructions in applying these correction factors.

2.3.1. Water Temperature

The temperature correction factor is primarily a viscosity correction factor required to account for the comparatively large variation in the viscosity of water over the operating temperature range of the Cyclosizer. Knowing the effective or the limiting particle separation size at one temperature level, the corresponding value at a second level can be calculated from the Stokes' Law relationship. In terms of the symbols given on page 2, the relationship between particle separation size and viscosity at two temperature levels, when other variables are constant, is:

$$\frac{d_1^2}{\eta_1} = \frac{d_2^2}{\eta_2}$$

$$\text{or } d_2 = d_1 \cdot \left| \frac{\eta_2}{\eta_1} \right|^{\frac{1}{2}}$$

Thus, if level 1 is the standard conditions (temperature 20°C),

$$\text{then } d_2 = d_1 \cdot f_2$$

$$\text{where } f_1 = \text{temperature correction factor}$$

Table 2 shows the viscosity of water at different temperatures and the correction factors calculated there from. This table is the basis of the correction factor graph, Figure 8.

2.3.2 Particle Density

The effect of variations in particle density similarly follows the Stokes' Law prediction and the particle separation sizes are readily calculated for those cases in which the particle density is at a value other than the stated standard. In terms of the symbols given on page 2, the relationship between particle separation size and particle density at two levels of the latter variable is:

$$d_1^2 (\sigma_1 - \rho) = d_2^2 (\sigma_2 - \rho)$$

and where the medium is water

$$d_1^2 (\sigma_1 - 1) = d_2^2 (\sigma_2 - 1)$$

hence, if d_1 and σ_1 represent the standard conditions (particle density 2.65 g/cm³),

$$\begin{aligned} \text{then } d_2 &= d_1 \left[\frac{1.65}{\sigma_2 - 1} \right]^{\frac{1}{2}} \\ &= d_1 \cdot f_2 \end{aligned}$$

where f_2 = particle density correction factor.

The correction factor graph, Figure 9, gives the numerical values of f_2 for a range of particle specific gravities.

Note that for the practical application of this correction factor, as in the calculating procedures and in figure 9, we have used the relative terminology of particle specific gravity rather than the absolute terminology of particle density.

2.3.3. Elutriation Flowrate

The relationship between flowrate and the limiting particle separation size of the cyclone is given by Kelsall and McAdam¹.

$$d_i = K [\text{flowrate}]^{-\frac{1}{2}}$$

Hence, for two different flowrates, the ratio of the limiting particle separation size is equal to the square root of the inverse flowrate ratio,

$$\text{and } d_2 = d_1 \left| \frac{\text{flowrate } 1}{\text{flowrate } 2} \right|^{\frac{1}{2}}$$

and if d_1 and *flowrate 1* represent the standard conditions,

$$\text{then } d_2 = d_1 \cdot f_3$$

where f_3 = flowrate correction factor

¹ D F Kelsall & J C H McAdam, Trans Ins of Chem Eng 41.84, 1963

Taking the standard flowrate of 11.6 litres per minute as the basis, correction factors have been determined for other flowrates and presented as a correction graph, Figure 10. In determining the flowrate correction factors, the actual quantity flowrate must be used, not the millimetre reading of the rotameter. The conversion between the volumetric flowrate and the rotameter reading is given by the lower scale of Figure 10.

The general effect of flowrate variations on the limiting particle separation size of the cyclones is a decrease with increasing flowrate. It is important that the flowrate be held constant within the accuracy of the rotameter during the timed elutriation period, and it is particularly important that it should not drop below the specified figure for this will result in the coarser particles moving downstream and reporting in other cyclones or being lost from the system.

The operating procedure described in Section 5.3 has been designed to prevent losses from flowrate alterations. Note that the sample is introduced into the water stream and a preliminary distribution is made at a flowrate higher than that used for the timed elutriation period. This ensures that during this period when there is a possibility of small flowrate fluctuations due to sample introduction, the cyclones are separating at a size smaller than the d_e for the operating conditions and there is no loss of coarser material.

After the introduction of the sample, the flowrate is lowered to the elutriating figure. This is equivalent to “opening up” the aperture and allowing the particles closer to the limiting size to be passed on to the next cyclone during the elutriation period at a controlled flowrate. At the completion of elutriation, the flowrate is increased again and the separation aperture “closes up” while the separate fractions are collected. This effectively prevents further elutriation for, after running at the lower flowrate, there would be no particles, marginal in respect to the higher flowrate, left in the cyclones.

The procedure for the removal of the final samples from the cyclones is also designed to prevent a lowering of the flowrate. Note that the solids are withdrawn starting from the downstream end of the unit, so that there is no decrease in the flow to those cyclones still containing solids.

Although the operating instructions are based on a “standard” flowrate, there is no reason why other flowrates should not be used, providing the corresponding flowrate correction factors are used to determine the effective particle separation sizes of the cyclones. In fact, if it is required to check the distribution at other separation sizes, the determination can be made at several flowrates within the range of 8 to 13 litres per minute.

2.3.4 Elutriation Time

The time correction factor which must be applied to the limiting particle separation sizes to determine their effective values is established by the calibration. For any fixed elutriation time the ratio between the limiting and effective separation sizes is constant for each cyclone and approximately constant for all cyclones.

Thus at time t :

$$f_4 = \frac{d_e}{d_i}$$

where f_4 = time correction factor

The numerical values of this factor are given in Figure 11.

The Cyclosizer characteristics in respect to the time variable follow the straight line relationships shown in Figure 4 when the elutriation time exceeds ten to fifteen minutes. For routine testing, ten minutes elutriation may be adequate. For more precise work, however, thirty minutes may be used and the effective separation sizes calculated with improved precision. Longer elutriation times do not materially improve the precision of the determination.

The slope of the calibration lines on Figure 4 are averaged to give the correction factor graph for the time variable, Figure 11. For maximum accuracy, the calibration procedure should be used to determine a time correction factor for each cyclone.

2.4 Calibration and Accuracy of Sizing

While the separation characteristics of the Cyclosizer obey Stokes' Law, with a high degree of reproducibility, there is no direct method of calculation of the limiting or the effective separation sizes for the cyclones. The unit is, therefore, calibrated against standards having a known sizing distribution by determining the limiting particle separation sizes for the cyclones at known levels of flowrate, particle density and temperature, and then correcting back to the standard conditions by the application of the correction factors.

The method for this determination is based on a study of the time variable. Samples of a standard sizing are run at the standard flowrate at several values of elutriating time and the percentage passing each cyclone is graphed against the reciprocal of time as shown in Figure 4. For each cyclone these values lie on straight lines which, when extrapolated to the ordinate (the reciprocal of infinite time), give the theoretical weight percent passing after infinite time. By referring these percentages to the known size distribution, the limiting separation sizes of the cyclones for the conditions of the test are obtained.

These limiting sizes are corrected back to the standard conditions of temperature and particle density by applying the correction factors obtained from Figure 8 and 9.

such that	d_i	=	$d_i \cdot f_1 \cdot f_2$
where	d_i	=	limiting particle separation size at the calibration conditions
and	d_i	=	limiting particle separation size at the standard conditions

Repeated testing with a calibrated Cyclosizer has indicated that sizing determinations on materials in which more than 50% is retained in the five cyclones and which are very carefully sampled, can be duplicated to the extent that the retained percentages in each cyclone will be all within ½% at a 95% confidence level. In most cases this corresponds to a repeated sizing split within 1 micron.

The figures of the calibration certificate and the associated tolerances show the range of the limiting particle separation sizes for the manufactured unit. These values to the nearest micron should be used for comparative and routine sizing where an accuracy of ±1 micron is satisfactory. For improved accuracy, however, the actual limiting particle separation sizes shown in the calibration certificate may be used. These values are quoted to the near 0.1 microns and can be considered accurate ±0.5 microns when used for very carefully conducted tests with a separately determined time correction factor.

If the cyclone assemblies are taken down and re-assembled for any reason, then this calibration is not necessarily valid and the unit should be checked against a standard for determinations requiring maximum accuracy.

It is emphasised that the limiting particle separation size quoted for a cyclone is not a finite measurement, but rather a parameter of the cyclone determined by experimental techniques and the above accuracy statement must be interpreted accordingly. In effect, the statement means that when a sizing distribution is determined as the percentage passing a certain cyclone having a stated effective separating size, there accuracy limited can be applied to the calculated d_e .

TABLE 2: Viscosity Correction for Temperatures

Temperature °C	Viscosity (Centipoises)	Correction Factor $f_1 = \left \frac{\eta_t}{\eta_{20}} \right ^{\frac{1}{2}}$
5	1.5188	1.229
10	1.3077	1.141
11	1.2713	1.125
12	1.2363	1.109
13	1.2028	1.094
14	1.1709	1.079
15	1.1404	1.065
16	1.1111	1.051
17	1.0828	1.038
18	1.0559	1.025
19	1.0299	1.012
20	1.0050	1.000
21	.9810	.988
22	.9579	.976
23	.9358	.965
24	.9141	.954
25	.8937	.943
26	.8737	.932
27	.8545	.922
28	.8360	.912
29	.8180	.902
30	.8007	.893
40	.6560	.808
50	.5494	.739

Figure 4

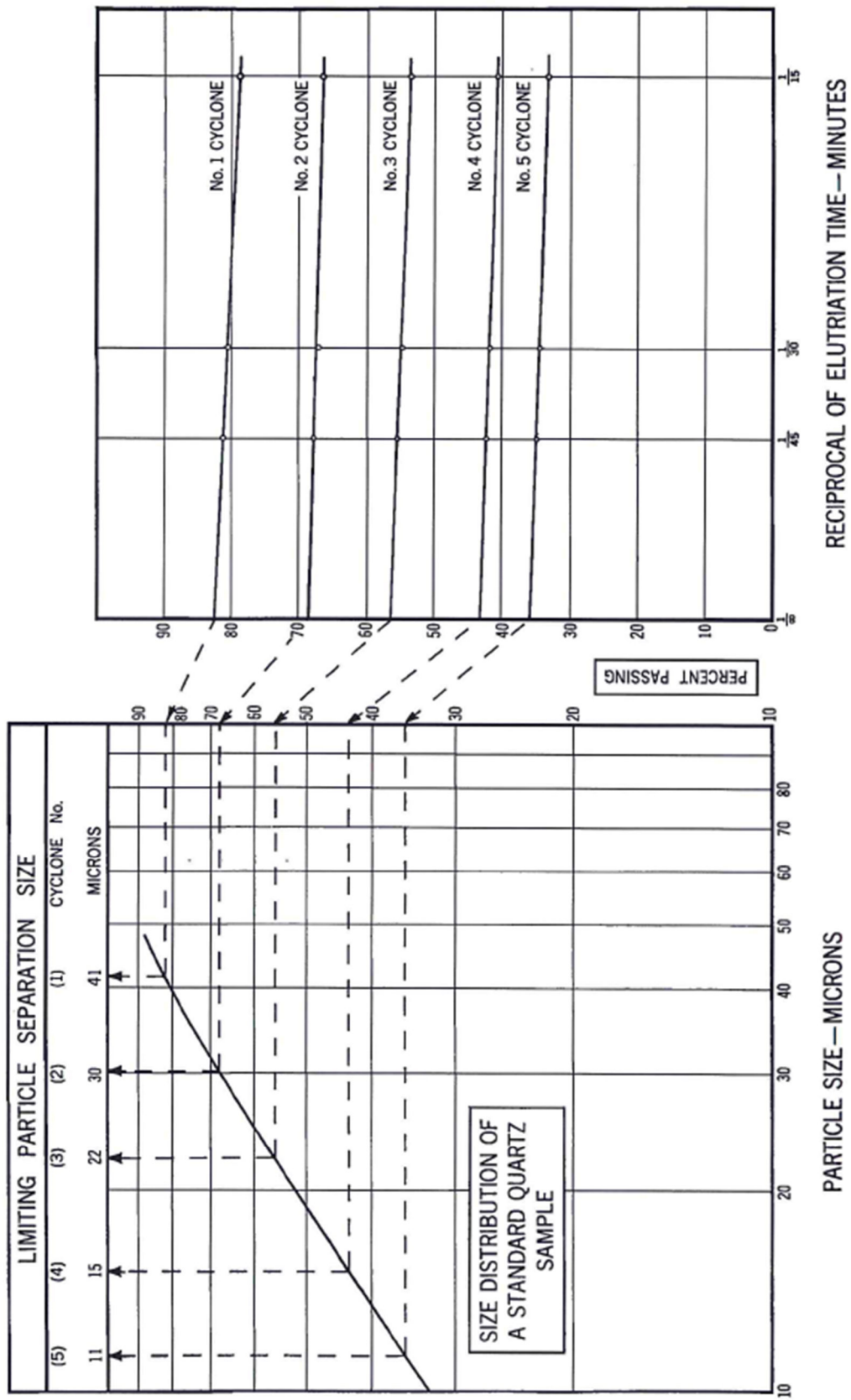

Section 3: General Description and Method of Operation

The Cyclosizer consists basically of a console cabinet on which the five cyclones are mounted together with a sample container assembly, rotameter, pressure gauge, thermometer and electrical control panel, as shown in Figure 5. In the lower portion of the cabinet there is a pump and water tank which is connected to the mains supply. Figure 6 shows the diagrammatic arrangement of these units.

The cyclones are mounted with the apex “vertically up” and are arranged in series such that the vortex outlet of each cyclone is the feed for the next in line. The vortex outlet from the final cyclone discharges to the drain manifold. The apex of each cyclone opens out into a small cylindrical chamber which is provided with a discharge valve. This valve is kept closed during the test and therefore the apex discharge of the cyclone is, in effect, closed. A flow control valve is provided as an integral part of the sample container assembly and water pumped from the tank through the five cyclones is manually controlled at a specified flowrate as indicated on the rotameter.

To determine the size distribution of a sample, a known weight is slurried with water and transferred to the sample container which is removed from the holder for this purpose. After charging, the sample container valve is closed, effectively sealing the sample within the container, which is then returned to the holder. Water is pumped through the circuit and the sample is bled into the water stream by slowly opening the sample container valve. This valve is adjusted so that the whole of the sample is released over a period of approximately five minutes, during which time the flowrate is maintained at maximum and there is a preliminary distribution of solids to the cyclones.

The initial distribution of the sample is an approximate size separation with each cyclone and apex chamber containing an excess of under size material. Controlled elutriation is then effected by reducing the water flow to a pre-determined figure and holding it constant for a specified time while particles smaller than the limiting particle separation size of each cyclone are gradually elutriated to the vortex outlet. Solids smaller than the limiting size of the final cyclone pass out with the waste water.

After the elutriation time has elapsed, the water flow is increased again and, as soon as practical thereafter, the solids which have collected in the five cyclones are discharged into separate beakers by opening the cyclone apex valves. The solids are settled, the water is decanted and the solids dried and weighed. The weight passing the final cyclone is determined by difference and the effective separating sizes of the five cyclones are calculated from the specified limiting sizes and the correction factors for the actual levels of the operating variables.

Figure 5 - General Arrangement.

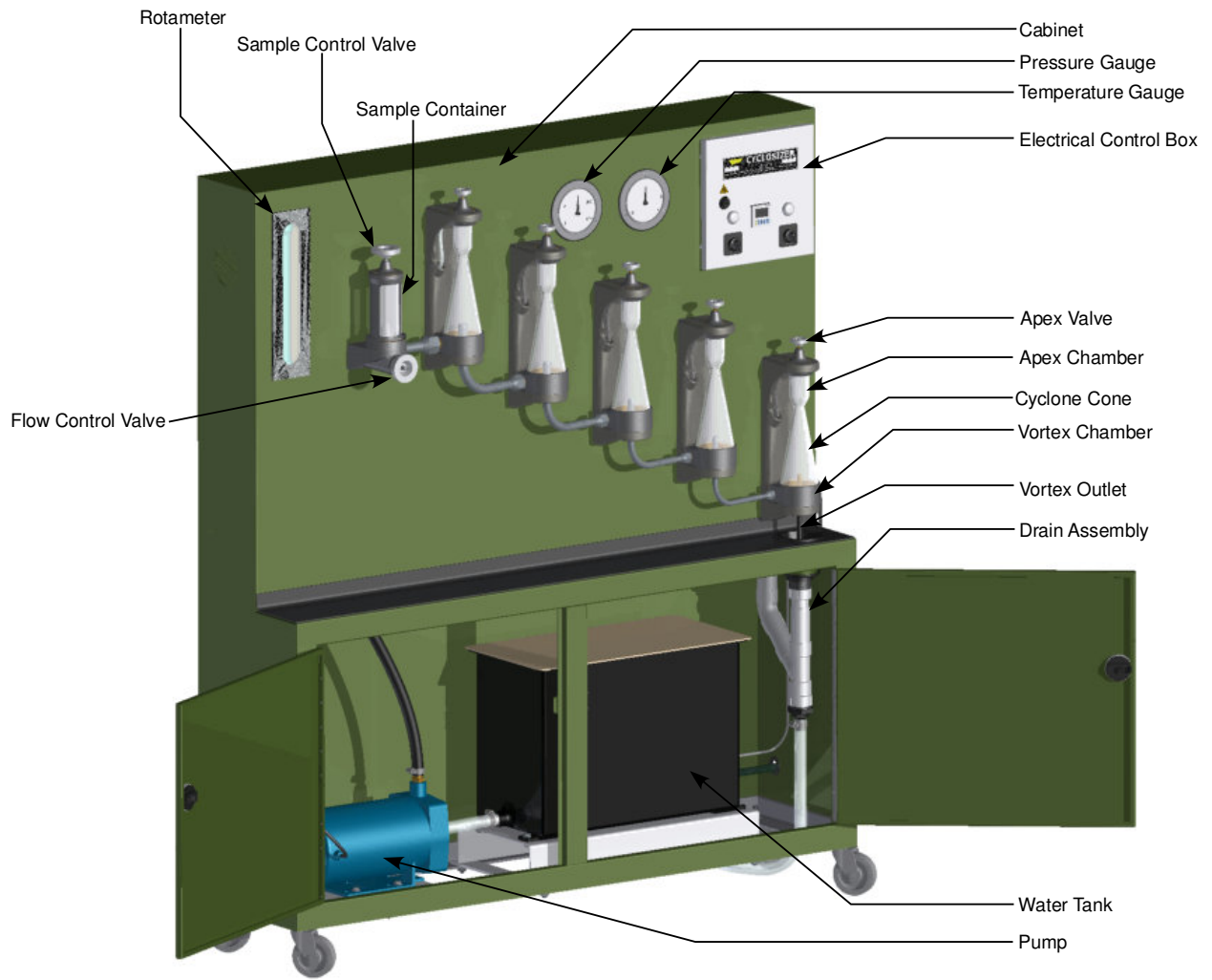
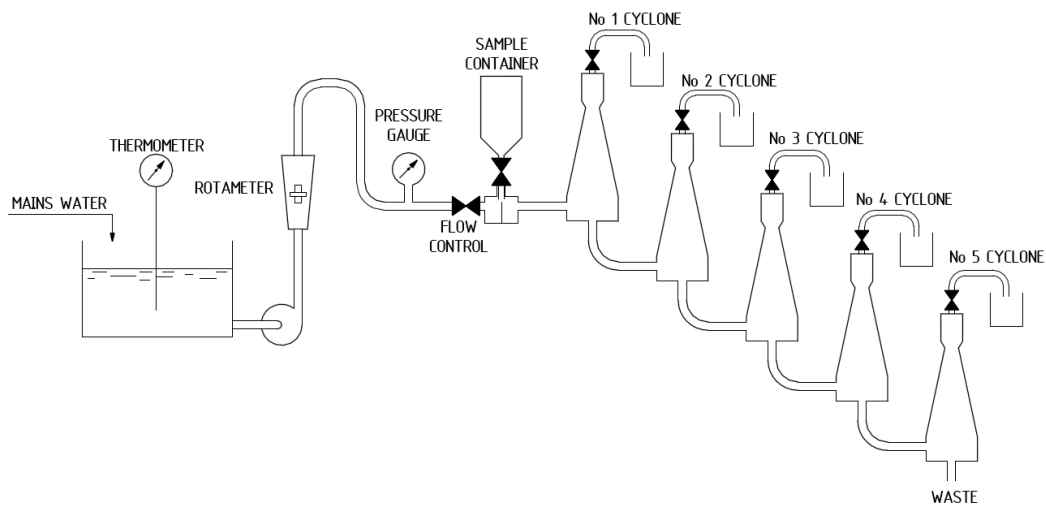

Figure 6 - Diagrammatic Arrangement.



Section 4: Sample Preparation

The range of materials for sub-sieve sizing is very wide and methods of sampling, sample sub-division and sample preparation become specific for the materials and circumstances involved. For this reason a general approach is given in the following as an introduction and guide in those instances where no procedure already exists.

4.1 Sub-Division of the Gross Sample

The degree of reproducibility of any apparatus designed to give a sizing distribution for a single batch of particulate material is dependent on the accuracy with which the original gross sample is reduced to a test sample. Very strict attention must be paid to this aspect of the determination, or the results which show a scatter which may not be representative of the gross sample.

For a sizing analysis using the Cyclosizer, the amount of sub-division required depends on the size distribution of the sample. The weight of the test sample used for the determination should be such that not more than 10 grams collect in any one cyclone. To determine an accurate maximum weight for a certain sample, a preliminary sizing may be run using approximately 20 grams and a maximum weight calculated from the results obtained. In every case, the final sample should be a true "split" weight and not a weight adjusted to a set figure by adding or removing small portions.

In the normal course of sizing determinations, one must deal with gross samples in both the wet and dry states. Where samples are received wet, it is strongly advised that they be reduced to the test sample and size without being dried, with the dry weight of the test sample being calculated by determining the moisture content of a duplicated sample. Fine samples which are first wet and then dried are inherently difficult to size, for, during the drying process, the fines form aggregates which are difficult, if not impossible, to re-disperse to the original particle size.

For the reduction of a gross sample of dry powdered material to a test sample of suitable size, a cone-and-quartering procedure followed by riffle splitting is usually satisfactory. If this is done carefully with due regard to the nature of the material, the results will be reproducible to the extent that the retained fractions will duplicate to $\pm \frac{1}{2}$ %.

A number of methods for the sub-division of gross samples of powders are given in British Standard 3406: Part 1: 1961. It is recommended that this publication be studied.

Techniques for the sub-division of gross samples of slurry are not so well developed as for dry powders. There are three methods in general use:

- I) Wet riffing
- II) Filtration followed by mixing and splitting the filter cake
- III) Withdrawing samples from the slurry while it is being agitated.

All methods, when carefully applied, will give satisfactory results.

4.2 Preparation of the Test Sample

The preparation of dry test samples is conveniently handled in a 250 ml beaker. The samples are pulped with 50 to 150 ml of water to which a little wetting agent may be added. The choice of wetting agent may vary with the type of material, but the usual commercial detergents have been found satisfactory. The pulped sample should be agitated to ensure thorough wetting of the particles. A laboratory stirrer may be used for this operation, but, if there is any tendency for the particles to break easily, then hand stirring should be used.

Dispersants, as distinct from wetting agents, are not required because the shear forces in the cyclones readily break up loosely held flocs and agglomerated material.

Wet samples in the form of filter cake, as distinct from slurry, are pulped as described for the dry samples. Slurries need no preparation unless they contain oversize material. Slurries that have been heavily dosed with polymer flocculants should be avoided. It is necessary to establish a dry weight of the material to be sized. For wet samples this can be achieved by drying a duplicate *moisture* sample.

The Cyclosizer is designed to operate on material in the sub-sieve range and all samples should be screened at 75 microns for materials up to a specific gravity of 4.0 and at 53 microns for materials with a specific gravity higher than 4.0. After pulping as described above, the test sample is wet screened, all under size being washed through in the conventional manner. A 3 litre beaker is used to retain the washings which are allowed to settle for one hour, the sides being occasionally tapped during this time. After settling, the liquor is carefully syphoned or decanted to waste until the volume remaining is approximately 200 ml. (Any solids still in suspension after one hour would be less than 10 microns and can be safely discarded.) The settled solids can then be transferred to the sample container for the sizing analysis.

Section 5: Particle Size Analysis

5.1 Installation Instructions

The Cyclosizer is shipped completely assembled, but requires attention in several aspects to make it operational:

- i) The cyclosizer should be set level
- ii) The hose from the water tank should be connected to the mains supply through an isolating valve. A minimum operating mains pressure of 70 kilopascal is required to obtain the necessary flowrate through the float valve in the tank.
- iii) The drainage hose must be run to a suitable floor drain.
- iv) Check to see that the pump switch is “off”. Connect the power cable through an isolating switch to your 220/240 volt, 10 amp power supply. Note that when the power is turned on to the unit, the alarm buzzer will sound. Simply press the alarm cancel button and it will be set for operation.

As the pump is fitted with a mechanical seal, it must not be switched on until the water tank is charged.

- v) **Remove the two shipping screws in the pump base plate.**

5.2 Commissioning Instructions

Before attempting any sizing analyses, operate the unit on water to check for transit damage and to familiarise yourself with the control procedures.

- i) Take the sample container and lubricate the O-ring seal by wetting it with a dilute soap solution.
- ii) Fit the sample container into the sample container holder on the Cyclosizer. Ensure that it is locked in position by making a 90 degree turn, so that one of the glass sides is facing you.
- iii) Turn on the mains water and charge the water tank.
- iv) Close all apex valves and the control valve. Turn the pump switch to “on”.
- v) Slowly open the control valve so that water flows through the cyclones and check for satisfactory operation.
- vi) When the Cyclosizer is used for the first time or when it is re-started after the water tank has been drained, it may be necessary to stop and start the pump several times to expel air trapped in the pump casing. The presence of air in the pump will be evidenced by the pressure gauge reading less than 260 kilopascals.

DO NOT UNDER ANY CIRCUMSTANCES ALLOW THE PUMP TO RUN DRY

5.3 Test Procedure

When the sample has been prepared as described in Section 4, select an elutriating flowrate (normally 11.6 L/min) and, by referring to Figure 10, determine the millimetre reading of the rotameter which corresponds to this selected valve. Then proceed as follows:

- i) With the pump “off”, remove the sample container from its holder by turning the container until one of the metal sides is facing you and pull straight upwards.
- ii) Open fully the valve on the sample container and empty out any water. Stand it inverted on the hand wheel of the valve.
- iii) Pour the test sample into the container and, using a wash bottle, wash the remaining solids out of the beaker into the container (figure 7a).
- iv) Continue to fill the sample container with clean water until the level is about halfway up the outside taper. Screw up the valve of the sample container until it is closed. At this stage the sample should be sealed within the container and all air eliminated.
- v) With the sample container valve closed, return it to the holder on the cyclosizer by a reversal of step (i) (figure 7b).
NOTE: It is imperative that you ensure that the sample container is correctly fitted in the holder and that a glass side is facing you before proceeding further.
- vi) Turn on the water supply to the constant head tank and wait until tank is full (ie until the float valve has closed).
- vii) Ensure that the control valve is *closed* and switch the pump on at the control panel.
- viii) Open the control valve slowly and allow the air to be expelled from the pipe work.
- ix) Open the control valve fully (figure 7c).
- x) Starting from No 1 cyclone, bleed the air from the cyclones by opening the apex valves one at a time. The last traces of air are sometimes difficult to remove from the No. 3 cyclone and, in such cases an alternative procedure can be used. Close both the apex valve and the control valve and allow the residual air to collect in the apex chamber, then open both valves fully and the air will be expelled. Since the vortex outlet of the No 5 cyclone is open to the atmosphere, it is not possible to remove the central air column and a “flash air column” will always be present.
- xi) With the control valve fully open, set the timer to 5 minutes and **open the sample container valve slowly** (figure 7d).
- xii) Manually regulate the container valve, so that by the time the alarm sounds, the sample has been completely discharged into the stream. Avoid sudden surges from the sample container.
- xiii) After the 5 minutes have elapsed, close the control valve until the flowmeter indicates the required elutriating flow. Set the time to the required elutriating time.
- xiv) When the alarm indicates the elutriation time has elapsed, cancel the alarm and turn the control valve to full flow.
- xv) *Starting with No 5 cyclone*, pull the plastic tube from the drain manifold, open the apex valve and discharge the solids from the apex chamber into a 1000ml beaker (figure 7e).
- xvi) Close No 5 discharge valve and proceed to No 4 cyclone and so on in turn to the other cyclones. Note the water temperature.
- xvii) Allow the beakers to stand for at least 20 minutes and decant the excess water.

- xviii) For final recovery and weighing, the sized fractions may be filtered on a tared paper and dried, or simply transferred to evaporating or petri dishes for drying without filtering. See Note 2.
- xix) Calculate the percentage passing No 5 cyclone as the difference between the initial weight and the sum of the weights of the separate fractions.

NOTES:

- 1) For continuous routine analyses two sample containers may be used to advantage.**
- 2) Please note that Whatman Filter Paper Grade 1 has an 11 μm pore size. As a result a portion of the C5 sample may be lost through the filter paper. The recommended filter paper is Whatman Grade 3 as this has a 6 μm pore size.**
- 3) If desired, a sample of fine solids passing the last cyclone can be recovered by collecting the waste water and settling. It has been found convenient to do this in plastic drums. Some 80% to 90% of the fine material is recovered by collecting the water over the first ten minutes of operation following the opening of the sample container valve.**
- 4) Do not allow the pump to run for any length of time with the control valve fully shut off. It could cause heat to build up in the pump.**
- 5) Water Temperature has a dramatic effect on the performance of the Cyclosizer. It is our recommendation that you run the Cyclosizer for at least 15 to 30 Mins to flush out the water in the Cyclosizer tank that may differ from the mains water temperature. If this is not done then the water temperature will most likely change through a run which will impact results.**

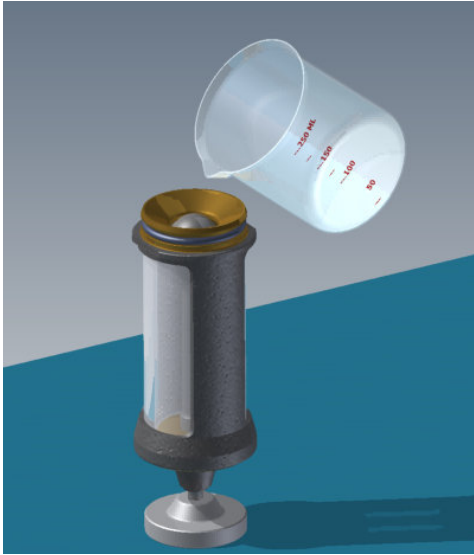

Figure 7a



Figure 7b

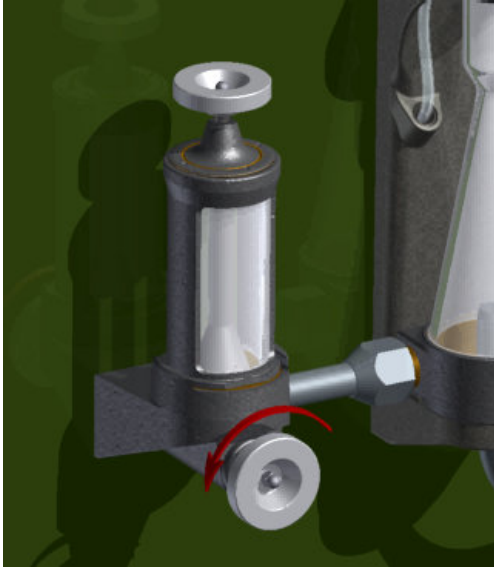

Figure 7c

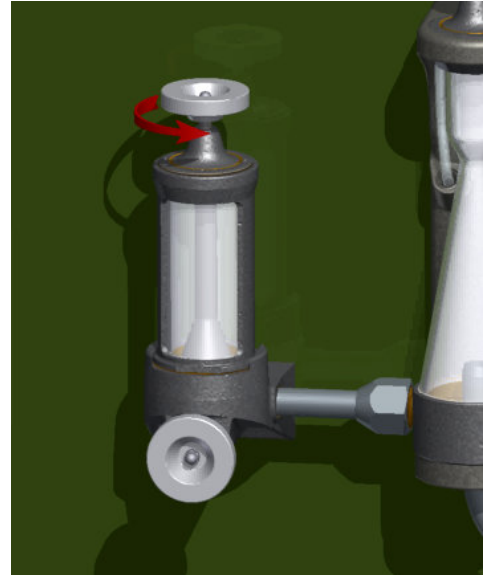

Figure 7d



Figure 7e

5.4 Calculations

After the weight percentages retained in the five cyclones have been determined, it is necessary to calculate the effective particle separation sizes under the conditions of the test.

To do this, a correction factor must be determined for each of the four variables and multiplied with the limiting particle separation size for each cyclone.

Thus for each cyclone:

$$d_e = d_i \cdot f_1 \cdot f_2 \cdot f_3 \cdot f_4$$

Where:

d_e = effective particle separation size

d_i = limiting particle separation size

f_1 = temperature correction factor for the water temperature of the test and is read off Figure 8.

f_2 = specific gravity correction factor for the particle specific gravity and is read off Figure 9.

f_3 = flowrate correction factor for the actual flowrate used and is read off figure 10

f_4 = time correction factor corresponding to the time of elutriation and is read off Figure 11.

In actual calculations, it is generally convenient to determine firstly an overall correction factor by multiplying the four separate factors together and using this figure to correct the limiting particle separation sizes.

In those cases where the sample consists of a mixture of several specific gravities, it may be convenient to report the results as percentage passing each cyclone and quote the effective separation sizes of the cyclones relative to the specific gravity of quartz.

Example of calculation procedure:

Assume that under the "standard" conditions, the cyclones are specified to separate as follows:

Cyclone	No 1	44 microns
	No 2	33 microns
	No 3	23 microns
	No 4	15 microns
	No 5	11 microns

These sizes are the limiting particle separation for a water flowrate of 11.6 litres/min, a water temperature of 20° and a particle specific gravity of 2.65.

Consider a test sizing of silicon carbide under the following conditions:

Flowrate 11.6 litres/min; water temperature 17°C; particle specific gravity 3.17; elutriation time 30 minutes.

Then from the graphs, the correction factors are:

Temperature	$f_1 =$	1.04
Particle sp. Gr.	$f_2 =$	0.88
Flowrate	$f_3 =$	1.00
Time	$f_4 =$	0.97

And the overall correction factor is $1.04 \times 0.88 \times 1.00 \times 0.97 = 0.89$, therefore, the effective separation sizes to the nearest micron are:

Cyclone	No 1	$44 \times 0.89=39$
	No 2	$33 \times 0.89=29$
	No 3	$23 \times 0.89=20$
	No 4	$15 \times 0.89=13$
	No 5	$11 \times 0.89=10$

For improved accuracy, the calculations may be based on the calibration certificate supplied with the equipment. This procedure is demonstrated in the illustration of the Warman Cyclosizer Result Sheet, on which calculations have been made on the basis of the calibration data shown in the lower left-hand corner of the sheet.

As an alternative to calculating the effective particle separation size, it is sometimes convenient to determine at the commencement of a test the operating flowrate required to give a specified effective separation size in one of the cyclones.

Example:

Referring to the standard conditions listed in the previous example, find the flowrate at which the No 1 cyclone would separate at 44 microns (relative to a particle sp. Gr. of 2.65) when the water temperature is 14°C and the intended elutriation time is 20 minutes.

In this case the basic equation is used again and the correction factors obtained from the graphs for particle specific gravity, temperature and time are substituted, together with the known limiting and effective particle separation sizes.

Thus:

$$\begin{aligned}d_e &= d_i \cdot f_1 \cdot f_2 \cdot f_3 \cdot f_4 \\44 &= 44 \times 1.075 \times 1.00 \times f_3 \times 0.95 \\f_3 &= 0.98\end{aligned}$$

From the flowrate correction graph, this corresponds to a flowrate of 12.0 litres/min.

The effective particle separation sizes of the other cyclones have the same $d_e : d_i$ ratio as the No 1 cyclone.

This later procedure has convenient application in routine sizings where it is often desirable to operate at equivalent hydrodynamic conditions and establish a standard procedure such that in all tests the Cyclosizer fractions have the same Stokes' settling velocities. For constant particle specific gravity values, the results can then be reported a constant particle sizes.

Cyclosizer Results Sheet

Sample No							
Sample wt	gross						
	tare						
	net (g)						
Temperature	oC						
Particle SP.GR							
Flowrate	L/Min						
Elutriation Time	min						
Correction Factor	(temp)						
" "	(sp.gr.)						
" "	(flow)						
" "	(time)						
N ^o 1 Sample wt	gross						
	tare						
	net						
N ^o 2 Sample wt	gross						
	tare						
	net						
N ^o 3 Sample wt	gross						
	tare						
	net						
N ^o 4 Sample wt	gross						
	tare						
	net						
N ^o 5 Sample wt	gross						
	tare						
	net						
% Retained	N ^o 1 Cycl						
	N ^o 2 Cycl						
	N ^o 3 Cycl						
	N ^o 4 Cycl						
	N ^o 5 Cycl						
% Passing	N ^o 1 Cycl						
	N ^o 2 Cycl						
	N ^o 3 Cycl						
	N ^o 4 Cycl						
	N ^o 5 Cycl						
Overall Correction Fact							
d _e N ^o 1 Cyclone							
d _e N ^o 2 Cyclone							
d _e N ^o 3 Cyclone							
d _e N ^o 4 Cyclone							
d _e N ^o 5 Cyclone							
Calibration Data		Remarks					
d ₁ N ^o 1 Cyclone =							
d ₂ N ^o 2 Cyclone =							
d ₃ N ^o 3 Cyclone =							
d ₄ N ^o 4 Cyclone =							
d ₅ N ^o 5 Cyclone =							

Sample of Completed Cyclosizer Results Sheet

WARMAN CYCLOSIZER RESULTS SHEET						
SAMPLE No.						
SAMPLE WT	gross	40.10	40.49	39.75	42.95	
	tare	10.36	12.53	11.60	14.03	
	net	29.74	27.96	28.15	28.92	
TEMPERATURE	°C	17.0	17.0	17.1	17.2	
PARTICLE SP.GR		3.17	3.17	3.17	3.17	
FLOWRATE	mm	180	180	180	180	
ELUTRIATION TIME	min	30	30	20	20	
CORRECTION FACTOR	(temp)	1.04	1.04	1.04	1.04	
"	" (sp.gr.)	0.88	0.88	0.88	0.88	
"	" (flow)	1.00	1.00	1.00	1.00	
"	" (time)	0.97	0.97	0.95	0.95	
No. 1 SAMPLE WT	gross	50.82	47.70	50.49	48.22	
	tare	39.90	37.39	39.92	37.39	
	net	10.92	10.31	10.57	10.83	
No. 2 SAMPLE WT	gross	52.27	45.09	51.97	45.15	
	tare	47.90	41.00	47.91	41.00	
	net	4.37	4.09	4.06	4.15	
No. 3 SAMPLE WT	gross	44.54	44.97	44.29	45.09	
	tare	40.37	41.08	40.38	41.07	
	net	4.17	3.89	3.91	4.02	
No. 4 SAMPLE WT	gross	47.36	41.38	47.18	41.51	
	tare	44.08	38.22	44.09	38.32	
	net	3.28	3.06	3.09	3.19	
No. 5 SAMPLE WT	gross	41.69	40.57	41.61	40.66	
	tare	39.90	38.90	39.91	38.90	
	net	1.79	1.67	1.70	1.76	
% RETAINED	No. 1 CYCLONE	36.7	36.9	37.5	37.4	
"	No. 2 "	14.7	14.6	14.4	14.4	
"	No. 3 "	14.0	13.9	13.9	13.9	
"	No. 4 "	11.0	11.0	11.0	11.0	
"	No. 5 "	6.0	6.0	6.0	6.1	
% PASSING	No. 1 CYCLONE	63.3	63.1	62.5	62.6	
"	No. 2 "	48.6	48.5	48.1	48.2	
"	No. 3 "	34.6	34.6	34.2	34.3	
"	No. 4 "	23.6	23.6	23.2	23.3	
"	No. 5 "	17.6	17.6	17.2	17.2	
OVERALL CORRECTION FACT		0.89	0.89	0.87	0.87	
d_e No. 1 CYCLONE	μm	37.4	37.4	36.5	36.5	
d_e No. 2	"	28.8	28.8	28.2	28.2	
d_e No. 3	"	20.4	20.4	19.9	19.9	
d_e No. 4	"	13.9	13.9	13.6	13.6	
d_e No. 5	"	10.5	10.5	10.3	10.3	
CALIBRATION DATA		REMARKS				
d_i No. 1 CYCLONE	= 42.0 μm	Standard silicon carbide samples (-75 μm) Duplicate tests at 20 and 30 minutes				
d_i No. 2	" = 32.4					
d_i No. 3	" = 22.9					
d_i No. 4	" = 15.6					
d_i No. 5	" = 11.8					

Figure 8: Temperature Correction Factor f_1 Chart

Table 3: Quick-Selection Table of Temperature Correction Factors

Temp (°C)	Correction Factor	Temp (°C)	Correction Factor	Temp (°C)	Correction Factor	Temp (°C)	Correction Factor	Temp (°C)	Correction Factor
5.0	1.230	11.1	1.125	17.2	1.037	23.3	0.962	29.4	0.897
5.1	1.228	11.2	1.123	17.3	1.036	23.4	0.960	29.5	0.896
5.2	1.226	11.3	1.121	17.4	1.035	23.5	0.959	29.6	0.895
5.3	1.224	11.4	1.120	17.5	1.033	23.6	0.958	29.7	0.895
5.4	1.223	11.5	1.118	17.6	1.032	23.7	0.957	29.8	0.894
5.5	1.221	11.6	1.117	17.7	1.031	23.8	0.956	29.9	0.893
5.6	1.219	11.7	1.115	17.8	1.030	23.9	0.955	30	0.892
5.7	1.217	11.8	1.114	17.9	1.028	24	0.954	30.1	0.891
5.8	1.215	11.9	1.112	18	1.027	24.1	0.952	30.2	0.890
5.9	1.213	12	1.111	18.1	1.026	24.2	0.951	30.3	0.889
6.0	1.212	12.1	1.109	18.2	1.024	24.3	0.950	30.4	0.888
6.1	1.210	12.2	1.108	18.3	1.023	24.4	0.949	30.5	0.887
6.2	1.208	12.3	1.106	18.4	1.022	24.5	0.948	30.6	0.886
6.3	1.206	12.4	1.105	18.5	1.020	24.6	0.947	30.7	0.886
6.4	1.204	12.5	1.103	18.6	1.019	24.7	0.946	30.8	0.885
6.5	1.203	12.6	1.102	18.7	1.018	24.8	0.944	30.9	0.884
6.6	1.201	12.7	1.100	18.8	1.017	24.9	0.943	31	0.883
6.7	1.199	12.8	1.099	18.9	1.015	25	0.942	31.1	0.882
6.8	1.197	12.9	1.097	19	1.014	25.1	0.941	31.2	0.881
6.9	1.195	13	1.096	19.1	1.013	25.2	0.940	31.3	0.880
7.0	1.194	13.1	1.094	19.2	1.012	25.3	0.939	31.4	0.880
7.1	1.192	13.2	1.093	19.3	1.010	25.4	0.938	31.5	0.879
7.2	1.190	13.3	1.091	19.4	1.009	25.5	0.937	31.6	0.878
7.3	1.188	13.4	1.090	19.5	1.008	25.6	0.936	31.7	0.877
7.4	1.187	13.5	1.088	19.6	1.006	25.7	0.935	31.8	0.876
7.5	1.185	13.6	1.087	19.7	1.005	25.8	0.933	31.9	0.875
7.6	1.183	13.7	1.086	19.8	1.004	25.9	0.932	32	0.875
7.7	1.181	13.8	1.084	19.9	1.003	26	0.931	32.1	0.874
7.8	1.179	13.9	1.083	20	1.001	26.1	0.930	32.2	0.873
7.9	1.178	14	1.081	20.1	1.000	26.2	0.929	32.3	0.872
8.0	1.176	14.1	1.080	20.2	0.999	26.3	0.928	32.4	0.871
8.1	1.174	14.2	1.078	20.3	0.998	26.4	0.927	32.5	0.870
8.2	1.173	14.3	1.077	20.4	0.996	26.5	0.926	32.6	0.870
8.3	1.171	14.4	1.076	20.5	0.995	26.6	0.925	32.7	0.869
8.4	1.169	14.5	1.074	20.6	0.994	26.7	0.924	32.8	0.868
8.5	1.167	14.6	1.073	20.7	0.993	26.8	0.923	32.9	0.867
8.6	1.166	14.7	1.071	20.8	0.992	26.9	0.922	33	0.866
8.7	1.164	14.8	1.070	20.9	0.990	27	0.921	33.1	0.866
8.8	1.162	14.9	1.069	21	0.989	27.1	0.920	33.2	0.865
8.9	1.161	15	1.067	21.1	0.988	27.2	0.919	33.3	0.864
9.0	1.159	15.1	1.066	21.2	0.987	27.3	0.918	33.4	0.863
9.1	1.157	15.2	1.064	21.3	0.985	27.4	0.917	33.5	0.862
9.2	1.155	15.3	1.063	21.4	0.984	27.5	0.916	33.6	0.861
9.3	1.154	15.4	1.062	21.5	0.983	27.6	0.915	33.7	0.861
9.4	1.152	15.5	1.060	21.6	0.982	27.7	0.914	33.8	0.860
9.5	1.150	15.6	1.059	21.7	0.981	27.8	0.913	33.9	0.859
9.6	1.149	15.7	1.057	21.8	0.979	27.9	0.912	34	0.858
9.7	1.147	15.8	1.056	21.9	0.978	28	0.911	34.1	0.857
9.8	1.146	15.9	1.055	22	0.977	28.1	0.910	34.2	0.857
9.9	1.144	16	1.053	22.1	0.976	28.2	0.909	34.3	0.856
10.0	1.142	16.1	1.052	22.2	0.975	28.3	0.908	34.4	0.855
10.1	1.141	16.2	1.051	22.3	0.973	28.4	0.907	34.5	0.854
10.2	1.139	16.3	1.049	22.4	0.972	28.5	0.906	34.6	0.853
10.3	1.137	16.4	1.048	22.5	0.971	28.6	0.905	34.7	0.852
10.4	1.136	16.5	1.047	22.6	0.970	28.7	0.904	34.8	0.852
10.5	1.134	16.6	1.045	22.7	0.969	28.8	0.903	34.9	0.851
10.6	1.133	16.7	1.044	22.8	0.967	28.9	0.902	35	0.850
10.7	1.131	16.8	1.043	22.9	0.966	29	0.901		
10.8	1.129	16.9	1.041	23	0.965	29.1	0.900		
10.9	1.128	17	1.040	23.1	0.964	29.2	0.899		
11.0	1.126	17.1	1.039	23.2	0.963	29.3	0.898		

Figure 9: Specific Gravity Correction Factor f_2 Chart

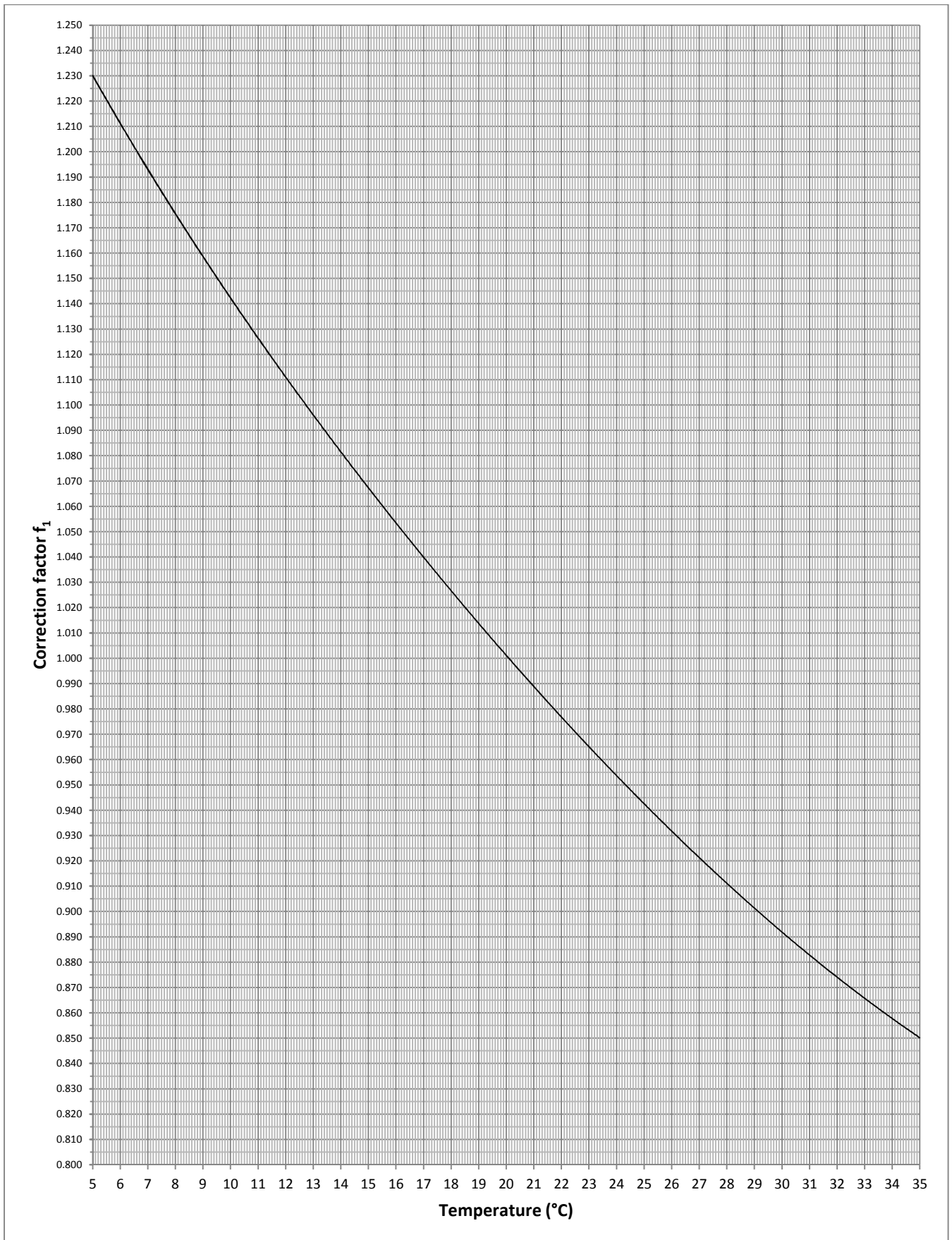
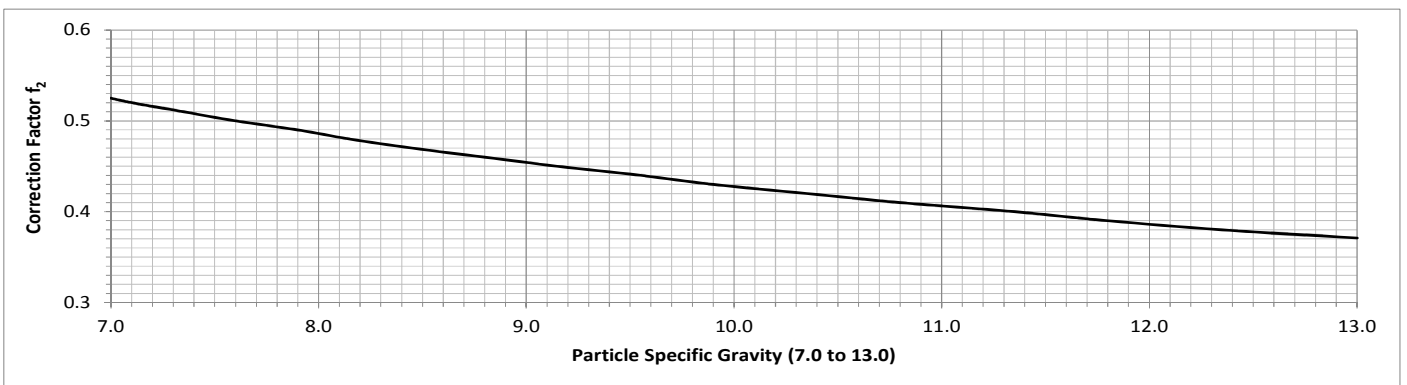
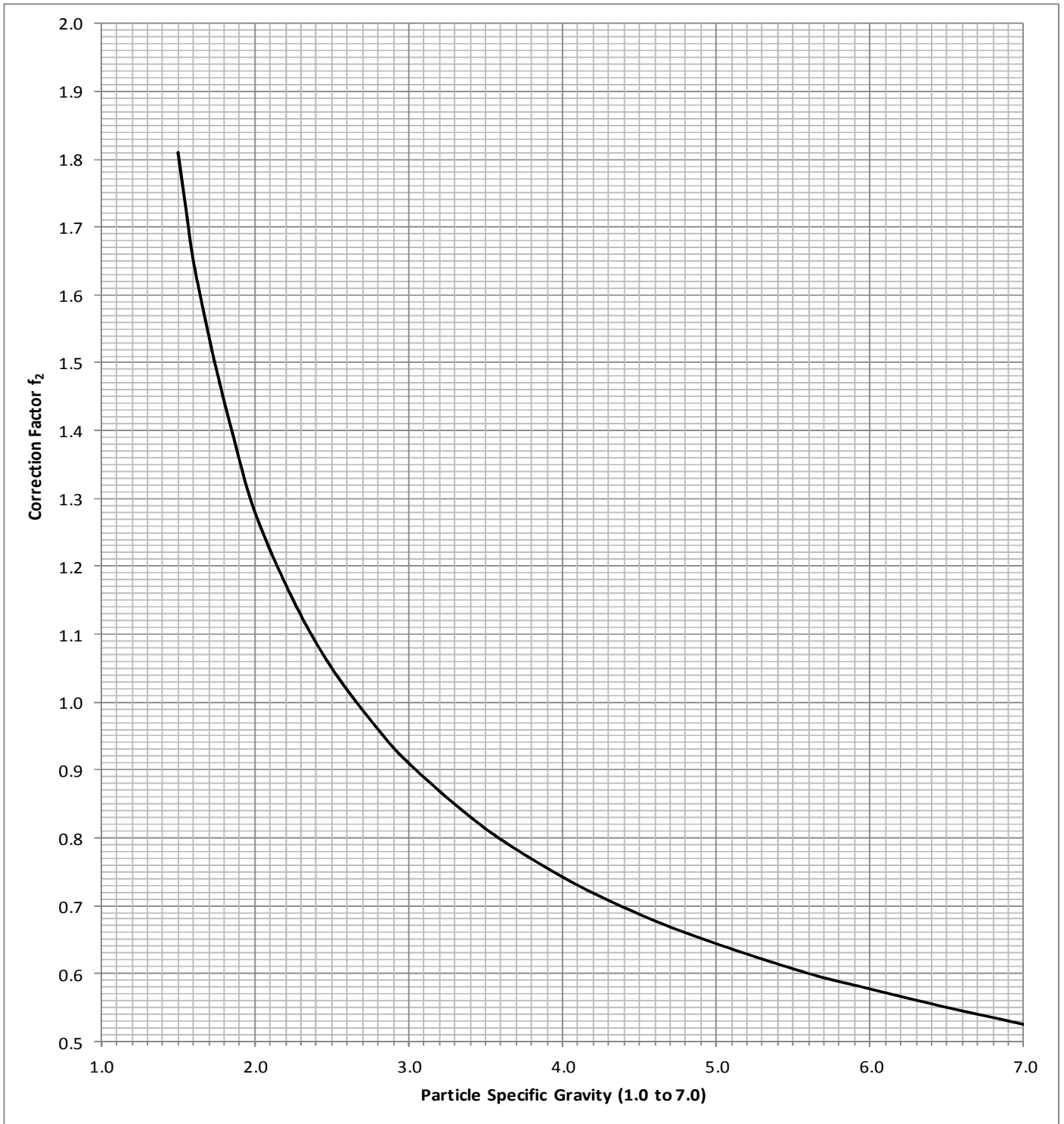

Figure 10: Flowrate Correction Factor f_3 Chart

Figure 11: Time Correction Factor f_4 Chart



Section 6: Mechanical Features, Care and Maintenance

6.1 Water Tank and Pump

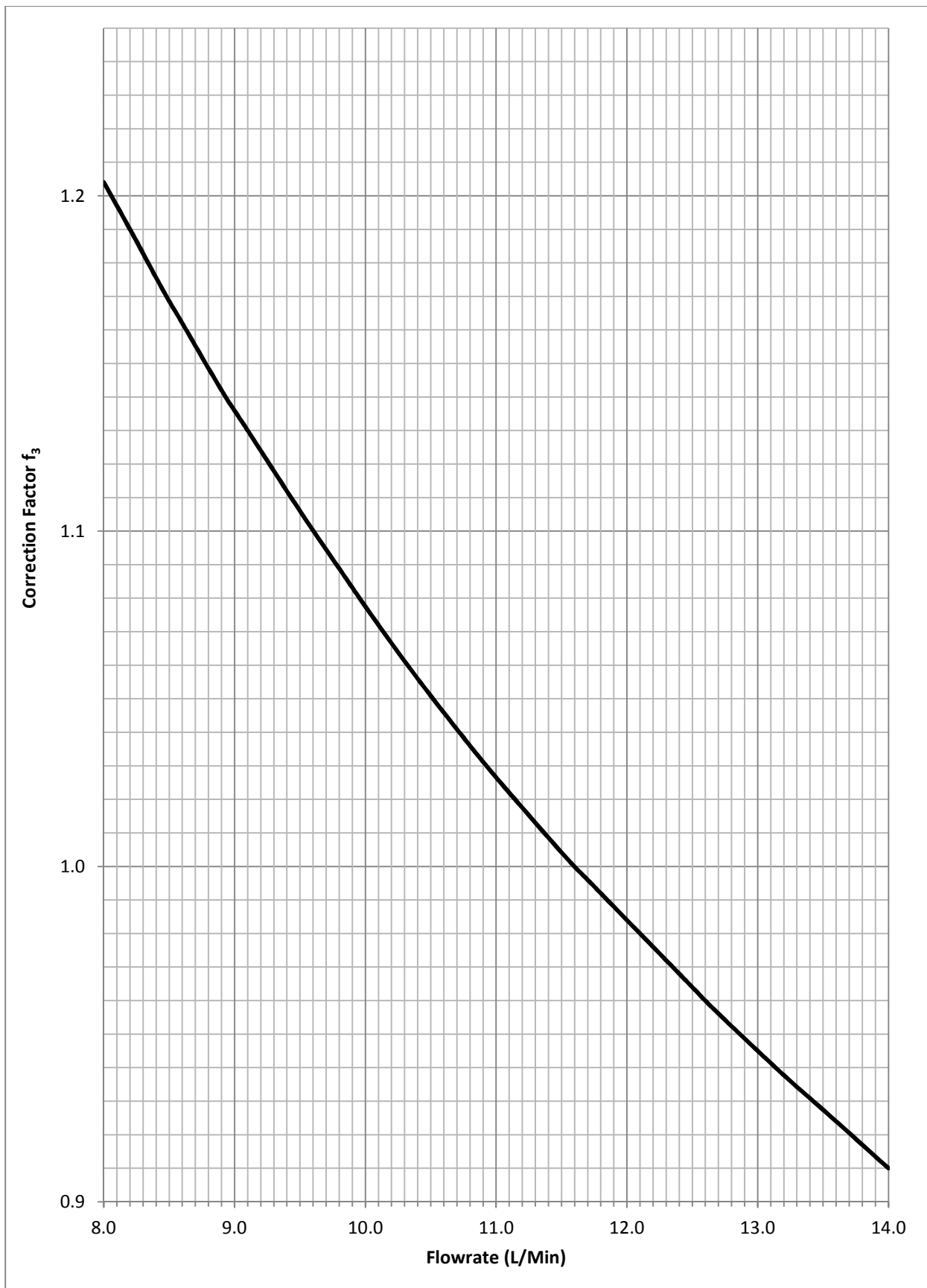
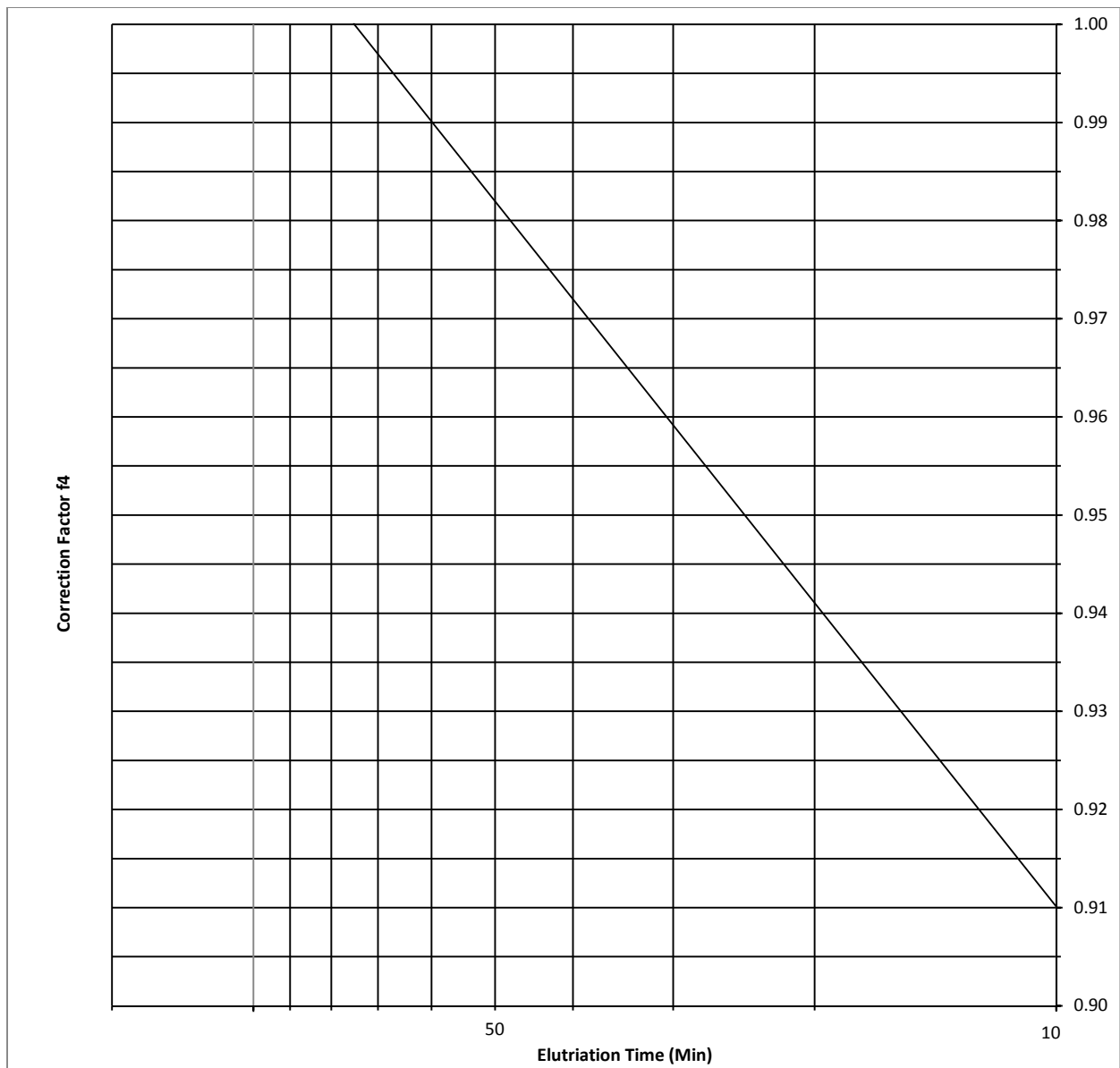
Elutriation water is drawn from the mains supply into the water tank through a float valve. The system is designed to maintain approximately constant head on the pump. The water pump is a single impeller centrifugal pump which is directly coupled to a motor, and has a mechanical seal. The pump units can be supplied to suit both 50 cycle and 60 cycle power supply. For further information on the use and maintenance of the pump see manufacturer's instruction manual.

During operation it may be found that sediment collects in the water tank and it is advisable to inspect the tank at regular intervals and clean out as required.

Important Note:

Never run the pump without water, lack of water may cause severe damage to the internal components.

Should the motor be replaced or revised in any way, it is essential that, the user reads the manufacturers use and maintenance instruction manual.

6.2 Rotameter

An inline analog flowmeter is used. This has a factory calibrated scale with a marking at 11.6L/Min. This is the designed flowrate of the Cyclosizer. The float within the flowmeter is prone to wear with prolonged use - if this occurs the complete flowmeter will need to be replaced.

It is due to the float's movement within the cylinder that the Cyclosizer - although possible when care is taken - should ideally not be transported on its side.

In older versions of the Cyclosizer a rotameter with a graduated scale was read in millimetres and this was converted to flowrate via a calibration curve.

6.3 Pressure Gauge

The pressure gauge is located in the water line after the rotameter on the upstream side of the control valve. In this position it should always read more or equal to 260 kilopascals when the pump is running. The main function of the pressure gauge is to indicate to the operator that the pump is developing its maximum head.

If the pressure gauge shows large fluctuations in water pressure or is indicating less than 255 kPa, check the following points:

- i) Stop and start the pump several times to check for air locked in the pump casing.

- ii) Check that the water mains pressure is sufficient to maintain a high level in the water supply tank.

6.4 Control Valve and Sample Container Assembly

The sample container assembly is designed so that a sample can conveniently be introduced into the water stream. The unit consists of a base casting, the sample container holder which carries the integral control valve, and removable sample container. The sample container is fitted to the holder by a spigot and socket joint, sealed with an O-ring and is locked in position by a 90° turn.

The opening in the low end of the container is closed by the spindle through the centre of the container and, with this opening closed; the contents of the container are isolated from the water flow through the Cyclosizer itself. As a routine measure or when any water leaks show in the assembly, the various rubber O-rings and rubber gaskets should be inspected and replaced if required. A pin spanner is provided for the control valve bonnet and clamp ring.

Figure 12 shows the parts comprising these assemblies.

6.5 Cyclone Assembly

The cyclone assemblies are clamped together and held in position on the panel by a specially designed bracket. The separate items of the assembly are designated as show in **Figure 13**.

The vortex chamber carries the tangential feed port and the vortex outlet tube. The apex valve at the top of the assembly discharges through a flexible plastic tube into the drain manifold. The metal parts in the cyclone assembly are brass, which the main body of the cyclone is clear moulded polycarbonate. Rubber gaskets between the separate parts seal the joints under pressure.

As far as possible the cyclone units should not be disturbed, but if a leak develops, the various seals may be inspected by unscrewing the clamp ring at the top of each assembly, using the larger end of the pin spanner, and dismantling. In re-assembling, care must be taken to ensure that all seals are in their proper place and correctly aligned. **DO NOT** tighten the clamp ring too tightly or the bracket will be distorted and the seals will not function. The vortex chambers, their connecting tubes and the cyclone assembly frames have been aligned and adjusted prior to despatch and should not be disturbed unless absolutely necessary. Should it be necessary to dismantle any of the cyclone assemblies the calibration should be checked using standard samples (CZ229). When the Cyclosizer is **NOT** in regular use, ensure that the apex valve is turned to the open position. This will reduce the risk of the apex valve washer sticking.

6.6 Control Panel and Electrical Features

The control panel (Electrical Control Box in Figure 5) includes an interval timer, a pump switch and a timer switch.

The timer is connected to the alarm buzzer to provide an audible alarm of lapsed time and is not in circuit with the pump.

The control panel is wired to the specifications of the Standards Association of Australia. Normal operating current is 5.5 amps for a 220/240 volt supply.

6.7 Drainage System

The discharge tubes from the apex valves and the vortex outlet from the final cyclone feed into a common drain manifold constructed from PVC fittings. A length of flexible tube is supplied for connection to the drain manifold. This tube should discharge at floor level or as close as practical thereto.

6.8 Dial Thermometer

The water temperature is measured by an analog thermometer with the primary element fitted in the water tank. The units are calibrated to the reading of this thermometer.

Drawing: Figure 12 - Control Valve and Sample Container Assemblies.

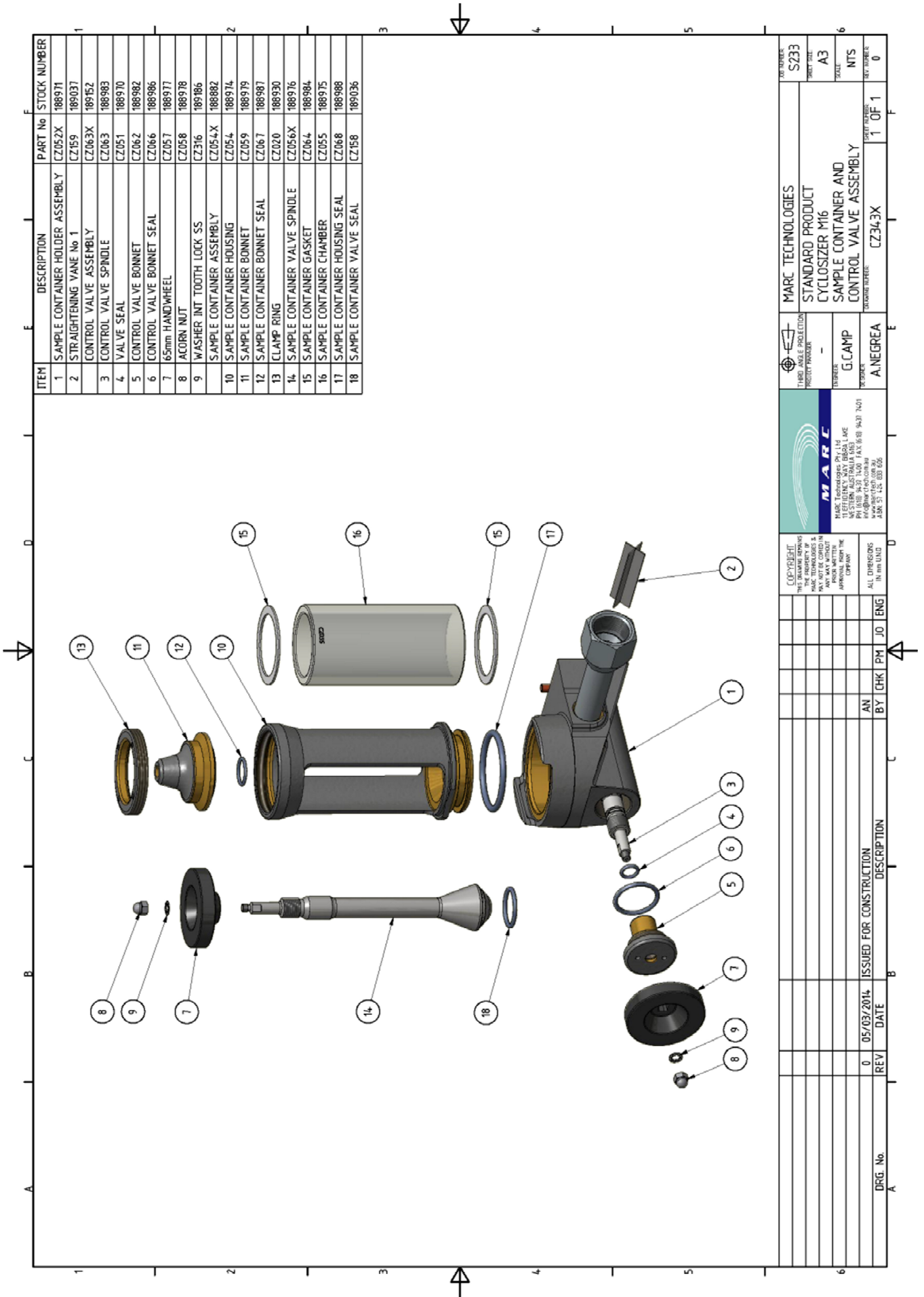

<p>MARC Technologies Pty Ltd 11 EFFENEY WAY BRISBANE LAKE QLD 4059 AUSTRALIA PH: (08) 432 1200 FAX: (08) 9420 7421 E: info@marctech.com.au A 504 ST. L.S. 533 026</p>		<p>THIRD ANGLE PROJECTION PRODUCT PRODUCED</p>	<p>REV. NO. S233 SHEET SIZE A3 SCALE NTS REV. NO. 0</p>
<p>COPYRIGHT THE DRAWING SHOWS MARC TECHNOLOGIES & MARC TECH CONSULTING PVT LTD. ALL RIGHTS RESERVED. APPROVED FOR THE COMPANY</p>		<p>TRADING NAME: CZ343X</p>	<p>REV. NO. 1 OF 1</p>
<p>ISSUED FOR CONSTRUCTION</p>		<p>DATE 05/03/2014</p>	
<p>DESCRIPTION</p>		<p>BY: AN</p>	
<p>DRG. No.</p>		<p>CHK: PM</p>	
<p>REV</p>		<p>ENG</p>	

Drawing: Figure 13 - Cyclone Assembly Details

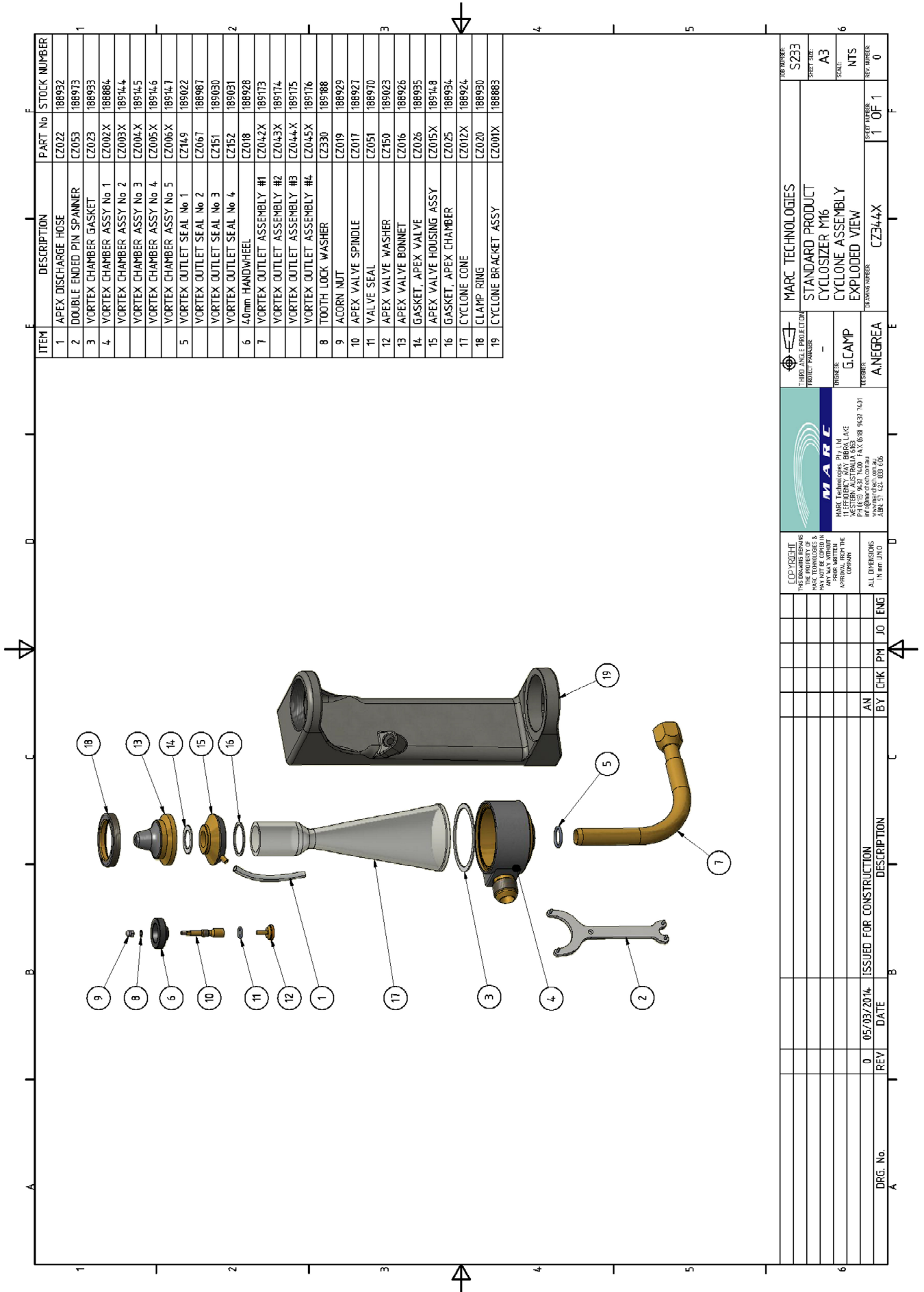

Recommended Spare Parts

Cyclone Gasket Kit (for 5 Cyclones) Part # CZ256 (Use this number if ordering in kit form)

Part #	Qty
CZ023	5
CZ025	5
CZ026	5
CZ051	5
CZ150	5

Sample Container Gasket Kit Part # CZ257 (Use this number if ordering in kit form)

Part	Qty
CZ064	2
CZ158	1
CZ067	1
CZ068	1

FOR INFORMATION AND SPARE PARTS

PLEASE REFER YOUR ENQUIRY TO:

EMAIL: INFO@MARCTECH.COM.AU

MARC TECHNOLOGIES PTY LTD

109 BANNISTER ROAD

CANNING VALE WA 6155

WESTERN AUSTRALIA