

**Deflection of Flexural Members -  
Macaulay's Method  
*3rd Year*  
*Structural Engineering***

**2010/11**

**Dr. Colin Caprani**

## Contents

<b>1. Introduction .....</b>	<b>4</b>
1.1 General.....	4
1.2 Background.....	5
1.3 Discontinuity Functions.....	16
1.4 Modelling of Load Types .....	21
1.5 Analysis Procedure .....	25
<b>2. Determinate Beams .....</b>	<b>28</b>
2.1 Example 1 – Point Load .....	28
2.2 Example 2 – Patch Load.....	36
2.3 Example 3 – Moment Load .....	41
2.4 Example 4 – Beam with Overhangs and Multiple Loads.....	45
2.5 Example 5 – Beam with Hinge.....	54
2.6 Problems .....	65
<b>3. Indeterminate Beams .....</b>	<b>68</b>
3.1 Basis.....	68
3.2 Example 6 – Propped Cantilever with Overhang .....	69
3.3 Example 7 – Indeterminate Beam with Hinge.....	75
3.4 Problems .....	88
<b>4. Indeterminate Frames.....</b>	<b>90</b>
4.1 Introduction.....	90
4.2 Example 8 – Simple Frame.....	91
4.3 Problems .....	100
<b>5. Past Exam Questions.....</b>	<b>101</b>
5.1 Summer 2003.....	101
5.2 Summer 2004.....	102
5.3 Summer 2007 .....	103
5.4 Autumn 2007 .....	104

5.5 Semester 2, 2007/8.....	105
5.6 Semester 2, 2008/9.....	106
5.7 Semester 2, 2009/10.....	107
<b>6. Appendix .....</b>	<b>108</b>
6.1 References.....	108

# 1. Introduction

## 1.1 General

Macaulay's Method is a means to find the equation that describes the deflected shape of a beam. From this equation, any deflection of interest can be found.

Before Macaulay's paper of 1919, the equation for the deflection of beams could not be found in closed form. Different equations for bending moment were used at different locations in the beam.

Macaulay's Method enables us to write a single equation for bending moment for the full length of the beam. When coupled with the Euler-Bernoulli theory, we can then integrate the expression for bending moment to find the equation for deflection.

Before looking at the deflection of beams, there are some preliminary results needed and these are introduced here.

Some spreadsheet results are presented in these notes; the relevant spreadsheets are available from [www.colincaprani.com](http://www.colincaprani.com).

## 1.2 Background

### Euler-Bernoulli Bending Theory

#### Basic Behaviour

Consider a portion of a bending member before and after the application of load:

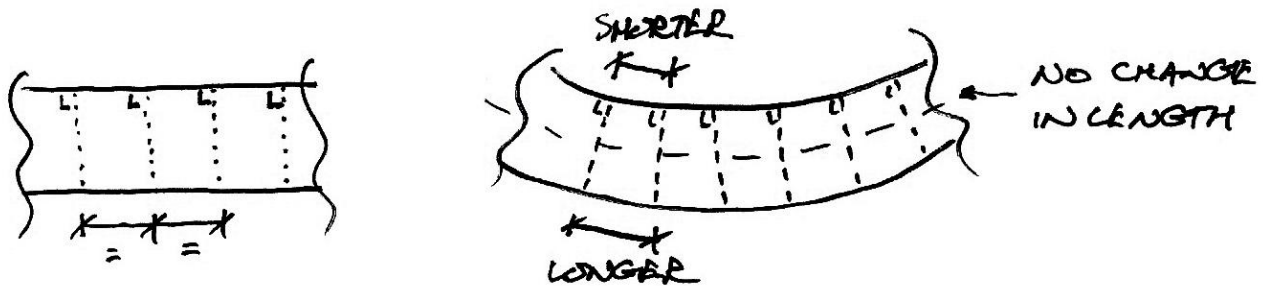

We can see that the fibres of the material contract on the upper face, and so they must be in compression. Since they lengthen on the lower face they must then be in tension. Thus the stresses vary from compression to tension over the depth of the beam and so at some point through the cross section, there must therefore be material which is neither shortening nor lengthening, and is thus unstressed. This is the neutral axis of the section.

#### Geometry of Deformation

Next we consider the above phenomenon in more detail. Consider a portion of the beam of length  $dx$  between planes  $AG$  and  $BH$ . We are particularly interest in the arbitrary fibre  $EF$  a distance  $y$  below the neutral axis,  $CD$ . Before loading,  $EF$  is the same distance as  $CD$ . After loading,  $C'D'$  remains the same length as  $CD$ , since it is the neutral axis to give:

$$dx = R d\theta$$

However, after loading,  $E'F'$  is no longer the same length as  $EF$ , but has increased in length. We have:

$$E'F' = (R + y)d\theta$$

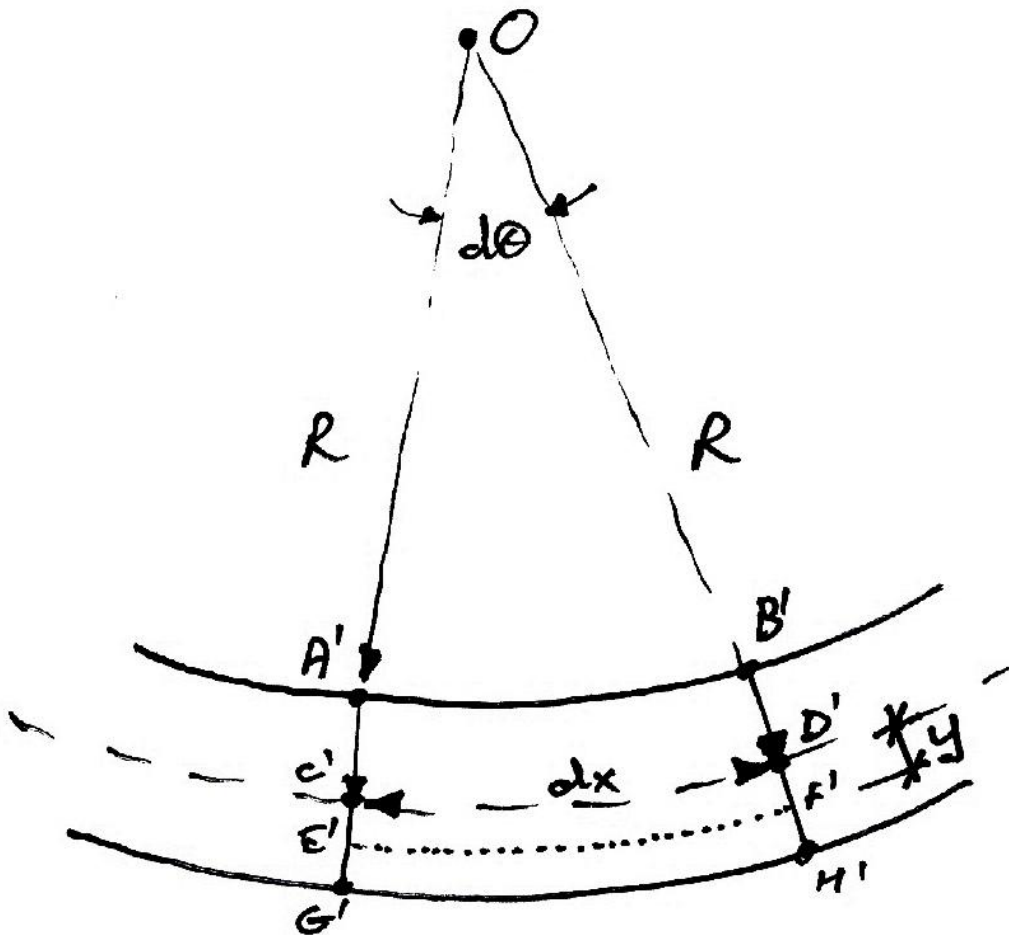
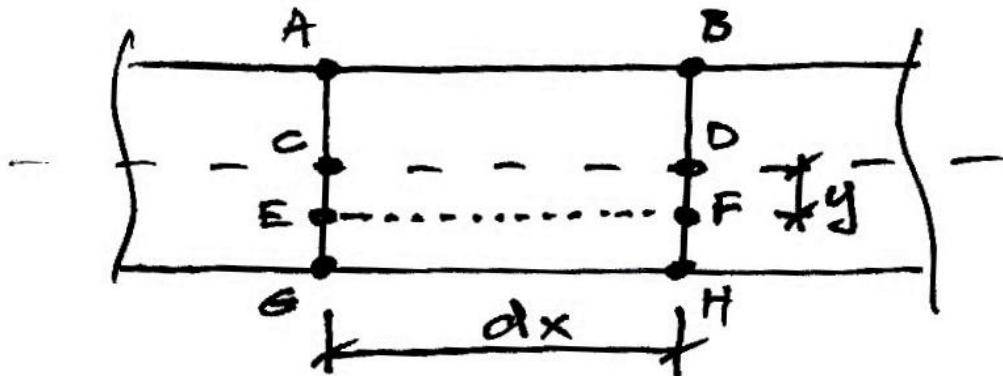

And so the strain in fibre  $EF$  is:

$$\varepsilon = \frac{\text{Change in length}}{\text{Original length}} = \frac{E'F' - EF}{EF}$$

But since  $EF = CD = dx = R d\theta$  we have:

$$\varepsilon = \frac{(R + y)d\theta - R d\theta}{R d\theta} = \frac{y}{R}$$

Thus:

$$\varepsilon = \frac{y}{R}$$

And so strain is distributed linearly across the section. Note that since no constitutive law was used in this derivation, this relationship holds for any form of material behaviour (linearly elastic, plastic etc.).

### **Linear Elastic Behaviour**

Next we will consider a specific case of material behaviour linear elasticity for which we know:

$$\varepsilon = \frac{\sigma}{E}$$

And so we have:

$$\varepsilon = \frac{\sigma}{E} = \frac{y}{R}$$

And this gives:

$$\sigma = \frac{E}{R} y$$

This is the equation of a straight line, and so the stress is linearly distributed across the cross section for a linear elastic material subject to bending.

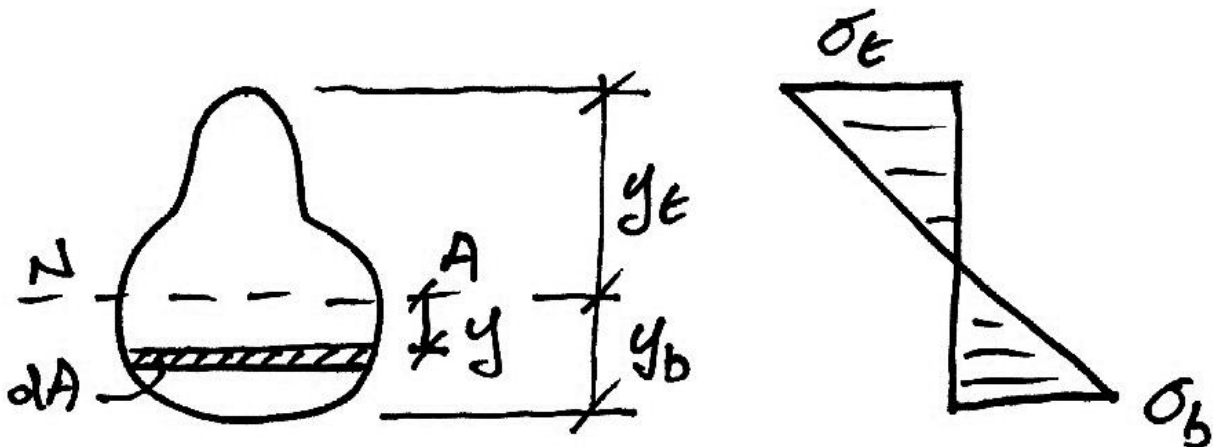

### Equilibrium with Applied Moment

Lastly, we will consider how these stresses provide resistance to the applied moment and force. Consider the elemental area  $dA$ , a distance  $y$  from the neutral axis, as shown in the diagram. The force that this area offers is:

$$dF = \sigma dA$$

And the total longitudinal force on the cross section is:



$$F = \int_A dF = \int_A \sigma dA$$

Since there is no applied axial force, only moment, this force must be zero:

$$F = \int_A \sigma dA = 0$$

Using the relationship we have for stress, we have:

$$\frac{E}{R} \int_A y dA = 0$$

Since  $E/R$  is not zero, the integral must be zero. This is the first moment of area about the neutral axis (where the integral must be zero. This is the first moment of area about the neutral axis (where  $y$  is measured from), and this is in turn the definition of the neutral axis: it passes through the centroidal axis of the cross section.

The total internal resisting moment offered by the stresses on the cross section is given by summing up the forces by distances from the neutral axis:

$$M = \int_A y dF = \int_A y \sigma dA = \frac{E}{R} \int_A y^2 dA$$

The last integral here is the *second moment of area* and is denoted  $I$ , to give:

$$M = \frac{EI}{R}$$

Thus:

$$\frac{M}{EI} = \frac{1}{R}$$

### Summary

Combining the relationships found gives the fundamental expression, sometimes called the *Engineers Theory of Bending*:

$$\frac{M}{I} = \frac{\sigma}{y} = \frac{E}{R}$$

This expression links stress, moment and geometry of deformation and is thus extremely important.

### General Deflection Equation

From the Euler-Bernoulli Theory of Bending, at a point along a beam, we know:

$$\frac{1}{R} = \frac{M}{EI}$$

where:

- $R$  is the radius of curvature of the point, and  $1/R$  is the curvature;
- $M$  is the bending moment at the point;
- $E$  is the elastic modulus;
- $I$  is the second moment of area at the point.

We also know that  $dx = R d\theta$  and so  $1/R = d\theta/dx$ . Further, for small displacements,  $\theta \approx \tan \theta \approx dy/dx$  and so:

$$\frac{1}{R} = \frac{d^2 y}{dx^2}$$

Where  $y$  is the deflection at the point, and  $x$  is the distance of the point along the beam. Hence, the fundamental equation in finding deflections is:

$$\frac{d^2 y}{dx^2} = \frac{M_x}{EI_x}$$

In which the subscripts show that both  $M$  and  $EI$  are functions of  $x$  and so may change along the length of the beam.

**Illustrative Example**

Consider the following beam with material property  $E = 30 \text{ kN/mm}^2$ :

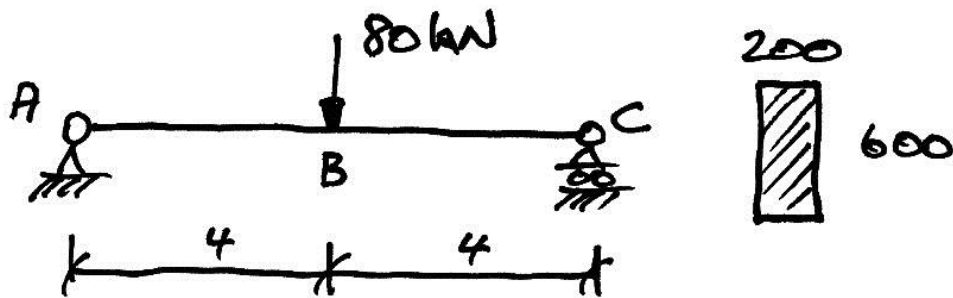

For this and subsequent problems, we need to know how to determine the flexural rigidity,  $EI$ , whilst being aware of the unit conversions required:

$$I = \frac{bd^3}{12} = \frac{200 \cdot 600^3}{12} = 36 \times 10^8 \text{ mm}^4$$

$$EI = \frac{(30)(36 \times 10^8)}{10^6} = 108 \times 10^3 \text{ kNm}^2$$

In which the unit conversions for this are:

$$EI = \frac{\left(\frac{\text{kN}}{\text{mm}^2}\right) \cdot (\text{mm}^4)}{(10^6 \text{ mm}^2 \text{ per m}^2)} = \text{kNm}^2$$

To find the deflection, we need to begin by getting an equation for the bending moments in the beam by taking free body diagrams:

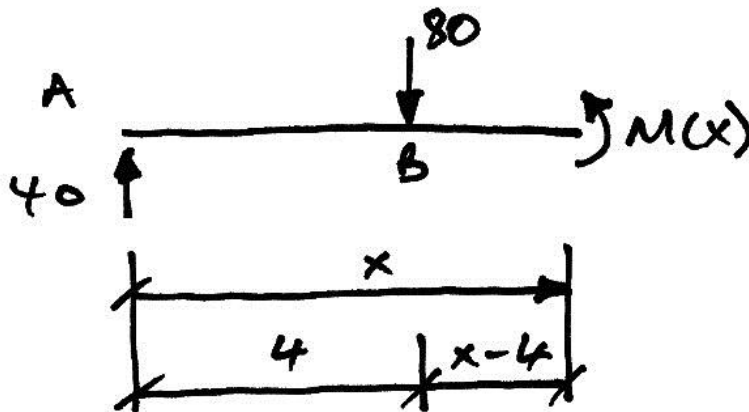
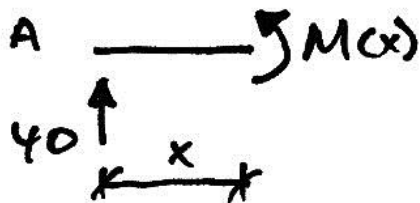
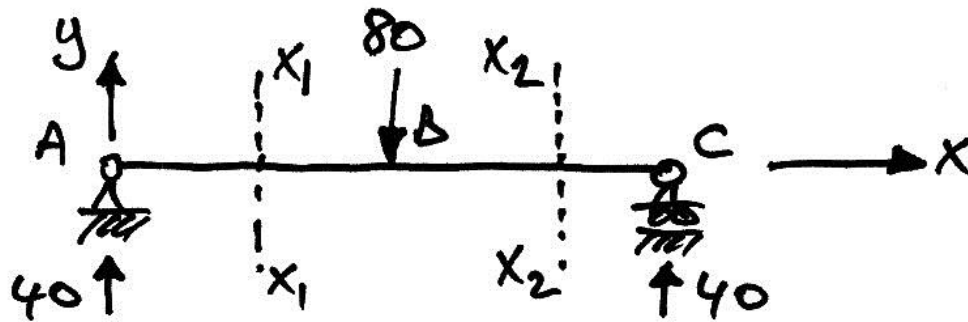

For the free-body diagram A to the cut  $X_1 - X_1$ ,  $\sum M$  about  $X_1 - X_1 = 0$  gives:

$$M(x) - 40x = 0$$

$$M(x) = 40x$$

For the second cut  $\sum M$  about  $X_2 - X_2 = 0$  gives:

$$M(x) - 40x + 80(x - 4) = 0$$

$$M(x) = 40x - 80(x - 4)$$

So the final equation for the bending moment is:

$$M(x) = \begin{cases} 40x & 0 \leq x \leq 4 \text{ (portion AB)} \\ 40x - 80(x-4) & 4 \leq x \leq 8 \text{ (portion BC)} \end{cases}$$

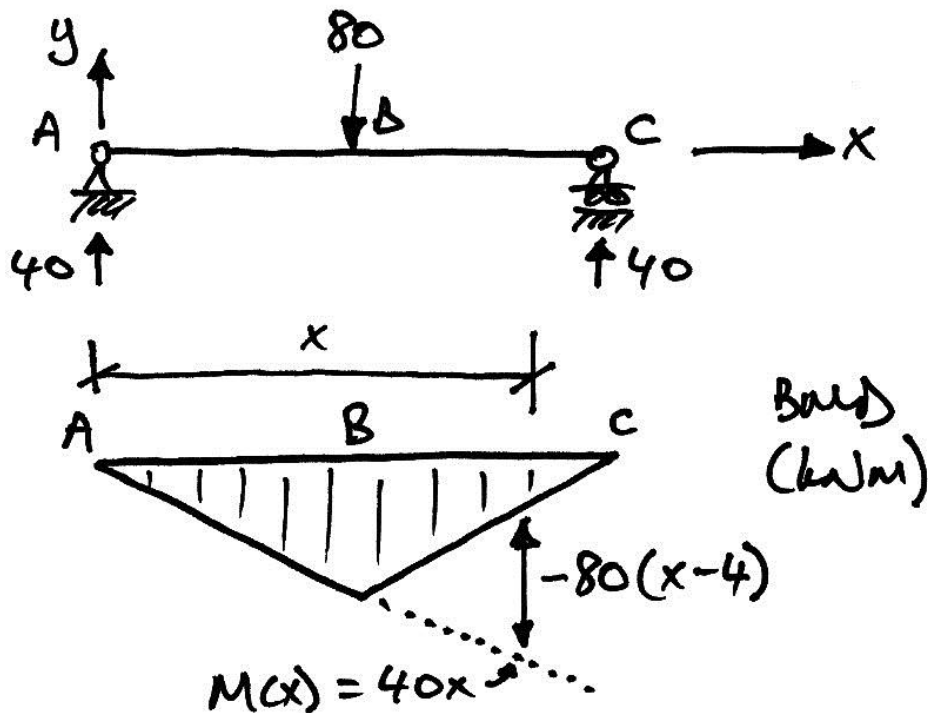

The equations differ by the  $-80(x-4)$  term, which only comes into play once we are beyond B where the point load of 80 kN is.

Going back to our basic formula, to find the deflection we use:

$$\frac{d^2y}{dx^2} = \frac{M(x)}{EI} \quad \Rightarrow \quad y = \iint \frac{M(x)}{EI} dx$$

But since we have two equations for the bending moment, we will have two different integrations and four constants of integration.

Though it is solvable, every extra load would cause two more constants of integration. Therefore for even ordinary forms of loading, the integrations could be quite involved.

The solution is to have some means of ‘turning off’ the  $-80(x-4)$  term when  $x \leq 4$  and turning it on when  $x > 4$ . This is what Macaulay’s Method allows us to do. It recognizes that when  $x \leq 4$  the value in the brackets,  $(x-4)$ , is negative, and when  $x > 4$  the value in the brackets is positive. So a Macaulay bracket,  $[\cdot]$ , is defined to be zero when the term inside it is negative, and takes its value when the term inside it is positive:

$$[x-4] = \begin{cases} 0 & x \leq 4 \\ x-4 & x > 4 \end{cases}$$

Another way to think of the Macaulay bracket is:

$$[x-4] = \max(x-4, 0)$$

The above is the essence of Macaulay’s Method. The idea of the special brackets is rooted in a strong mathematical background which is required for more advanced understanding and applications. So we next examine this background, whilst trying not to lose sight of its essence, explained above.

**Note:** when implementing a Macaulay analysis in MS Excel or Matlab, it is easier to use the `max` function, as above, rather than lots of `if` statements.

### 1.3 Discontinuity Functions

#### Background

This section looks at the mathematics that lies behind Macaulay's Method. The method relies upon special functions which are quite unlike usual mathematical functions. Whereas usual functions of variables are continuous, these functions have discontinuities. But it is these discontinuities that make them so useful for our purpose. However, because of the discontinuities these functions have to be treated carefully, and we will clearly define how we will use them. There are two types.

#### Notation

In mathematics, discontinuity functions are usually represented with angled brackets to distinguish them from other types of brackets:

- Usual ordinary brackets:  $(\cdot)$   $[\cdot]$   $\{\cdot\}$
- Usual discontinuity brackets:  $\langle \cdot \rangle$

However (and this is a big one), we will use square brackets to represent our discontinuity functions. This is because in handwriting they are more easily distinguishable than the angled brackets which can look similar to numbers.

Therefore, we adopt the following convention here:

- Ordinary functions:  $(\cdot)$   $\{\cdot\}$
- Discontinuity functions:  $[\cdot]$



### Macaulay Functions

Macaulay functions represent quantities that begin at a point  $a$ . Before point  $a$  the function has zero value, after point  $a$  the function has a defined value. So, for example, point  $a$  might be the time at which a light was turned on, and the function then represents the brightness in the room: zero before  $a$  and bright after  $a$ .

Mathematically:

$$F_n(x) = [x-a]^n = \begin{cases} 0 & \text{when } x \leq a \\ (x-a)^n & \text{when } x > a \end{cases}$$

where  $n = 0, 1, 2, \dots$

When the exponent  $n = 0$ , we have:

$$F_0(x) = [x-a]^0 = \begin{cases} 0 & \text{when } x \leq a \\ 1 & \text{when } x > a \end{cases}$$

This is called the step function, because when it is plotted we have:

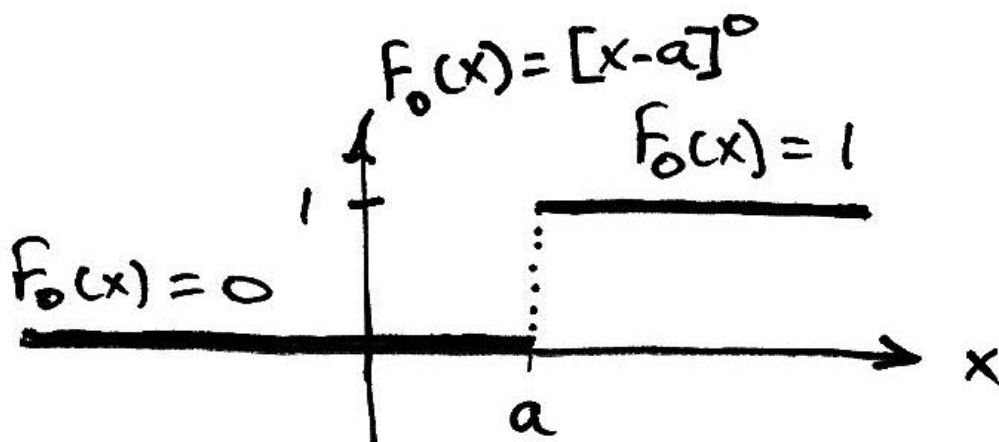

For  $n = 1$ , we have:

$$F_1(x) = [x-a]^1 = \begin{cases} 0 & \text{when } x \leq a \\ x-a & \text{when } x > a \end{cases}$$

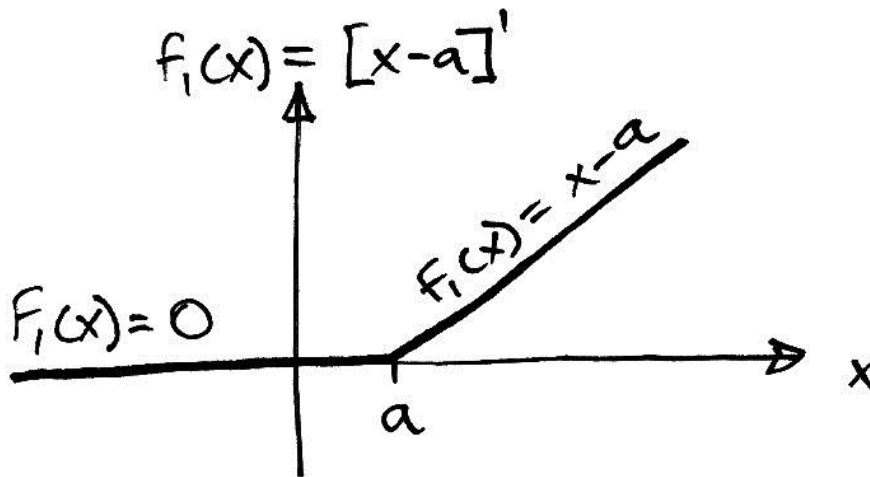

For  $n = 2$ , we have:

$$F_1(x) = [x-a]^2 = \begin{cases} 0 & \text{when } x \leq a \\ (x-a)^2 & \text{when } x > a \end{cases}$$

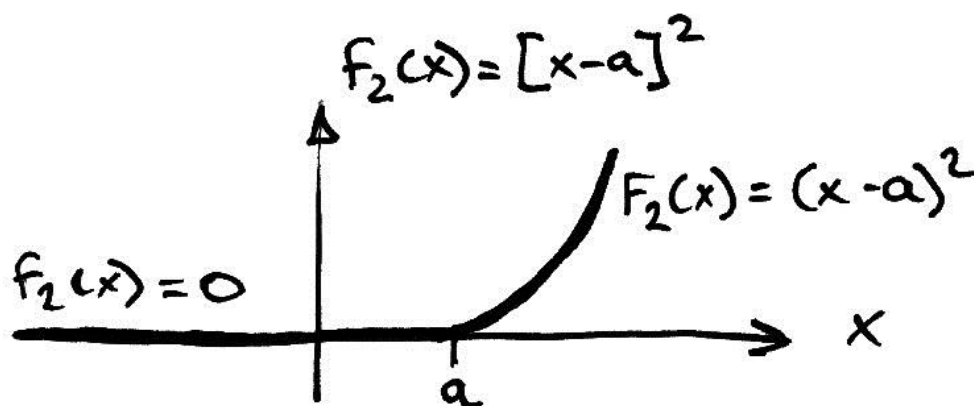

And so on for any value of  $n$ .

### Singularity Functions

Singularity functions behave differently to Macaulay functions. They are defined to be zero everywhere except point  $a$ . So in the light switch example the singularity function could represent the action of switching on the light.

Mathematically:

$$F_n(x) = [x-a]^n = \begin{cases} 0 & \text{when } x \neq a \\ \infty & \text{when } x = a \end{cases}$$

where  $n = -1, -2, -3, \dots$

The singularity arises since when  $n = -1$ , for example, we have:

$$F_{-1}(x) = \left[ \frac{1}{x-a} \right] = \begin{cases} 0 & \text{when } x \neq a \\ \infty & \text{when } x = a \end{cases}$$

Two singularity functions, very important for us, are:

1. When  $n = -1$ , the function represents a unit force at point  $a$ :

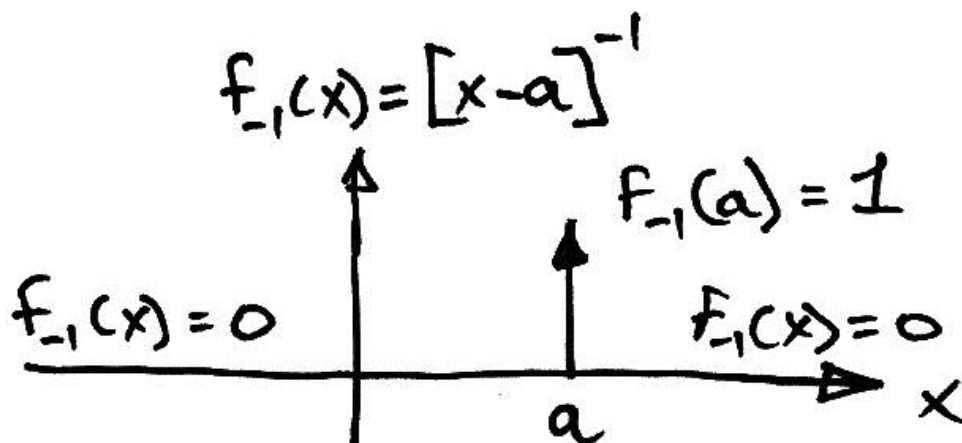

2. When  $n = -2$ , the function represents a unit moment located at point  $a$ :

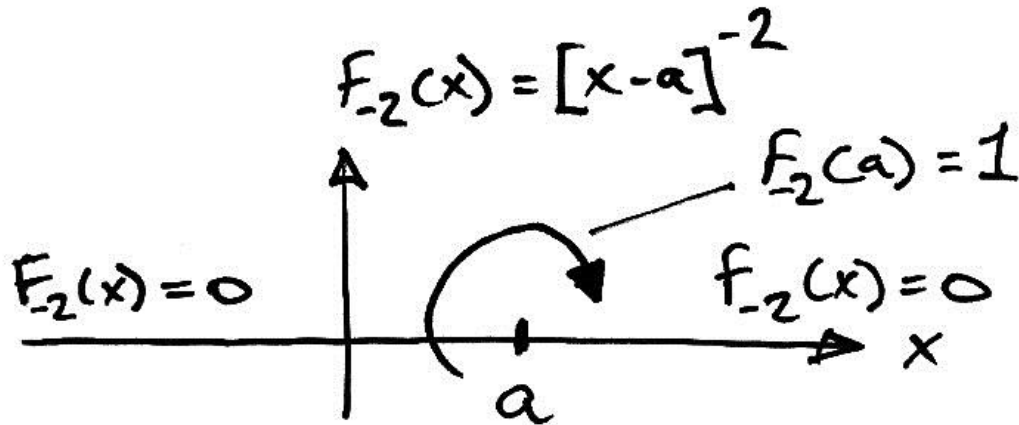

### Integration of Discontinuity Functions

These functions can be integrated almost like ordinary functions:

Macaulay functions ( $n \geq 0$ ):

$$\int_0^x F_n(x) = \frac{F_{n+1}(x)}{n+1} \quad \text{i.e.} \quad \int_0^x [x-a]^n = \frac{[x-a]^{n+1}}{n+1}$$

Singularity functions ( $n < 0$ ):

$$\int_0^x F_n(x) = F_{n+1}(x) \quad \text{i.e.} \quad \int_0^x [x-a]^n = [x-a]^{n+1}$$

## 1.4 Modelling of Load Types

### Basis

Since our aim is to find a single equation for the bending moments along the beam, we will use discontinuity functions to represent the loads. However, since we will be taking moments, we need to know how different load types will relate to the bending moments. The relationship between moment and load is:

$$w(x) = \frac{dV(x)}{dx} \quad \text{and} \quad V(x) = \frac{dM(x)}{dx}$$

Thus:

$$w(x) = \frac{d^2M(x)}{dx^2}$$
$$M(x) = \iint w(x) dx$$

So we will take the double integral of the discontinuity representation of a load to find its representation in bending moment.

### **Moment Load**

A moment load of value  $M$ , located at point  $a$ , is represented by  $M[x-a]^{-2}$  and so appears in the bending moment equation as:

$$M(x) = \iint M[x-a]^{-2} dx = M[x-a]^0$$

### **Point Load**

A point load of value  $P$ , located at point  $a$ , is represented by  $P[x-a]^{-1}$  and so appears in the bending moment equation as:

$$M(x) = \iint P[x-a]^{-1} dx = P[x-a]^1$$

### **Uniformly Distributed Load**

A UDL of value  $w$ , beginning at point  $a$  and carrying on to the end of the beam, is represented by the step function  $w[x-a]^0$  and so appears in the bending moment equation as:

$$M(x) = \iint w[x-a]^0 dx = \frac{w}{2}[x-a]^2$$

**Patch Load**

If the UDL finishes before the end of the beam – sometimes called a patch load – we have a difficulty. This is because a Macaulay function ‘turns on’ at point  $a$  and never turns off again. Therefore, to cancel its effect beyond its finish point (point  $b$  say), we turn on a new load that cancels out the original load, giving a net load of zero, as shown:

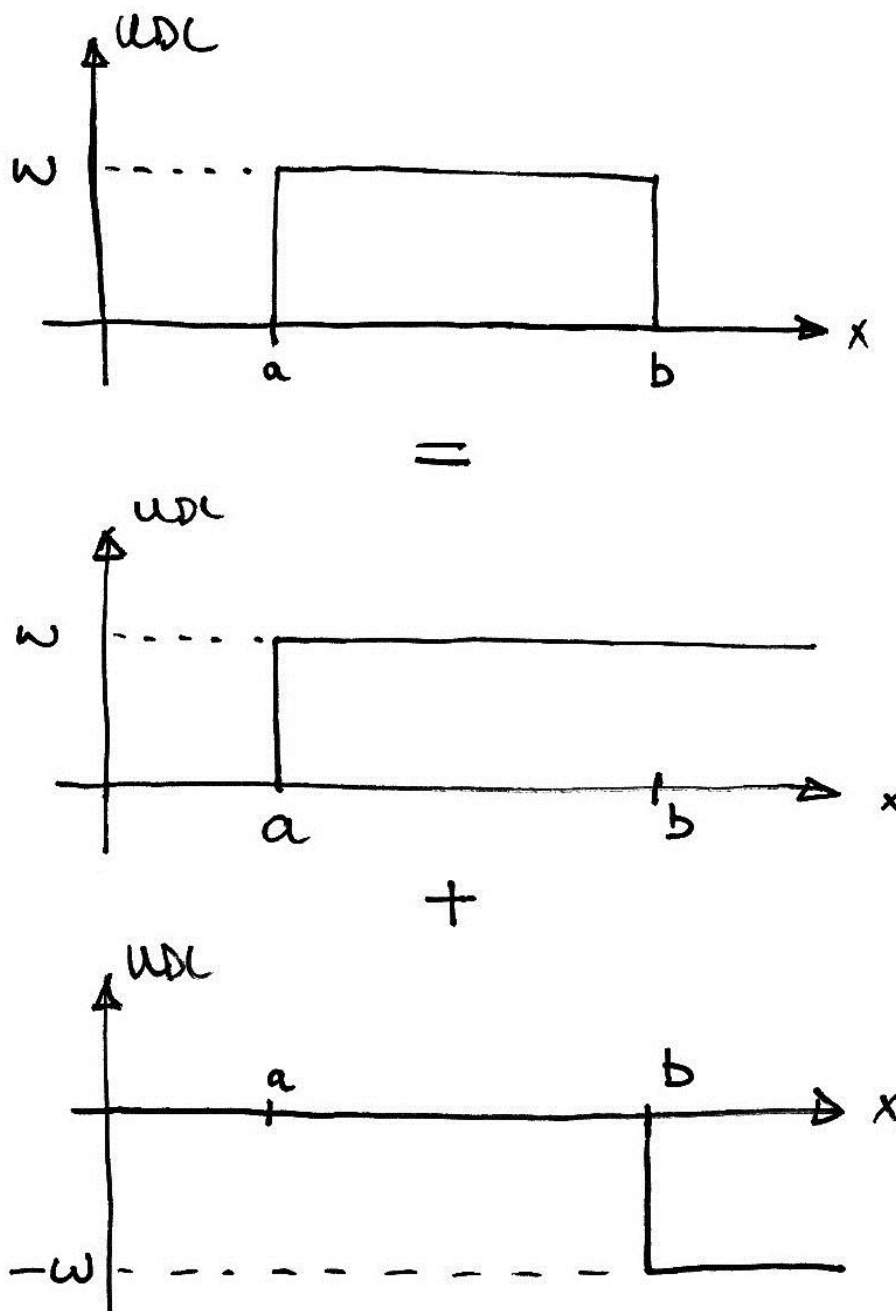

Structurally this is the same as doing the following superposition:

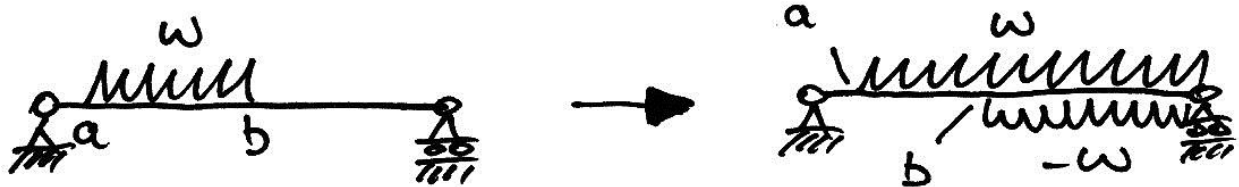

And finally mathematically we represent the patch load that starts at point  $a$  and finishes at point  $b$  as:

$$w[x-a]^0 - w[x-b]^0$$

Giving the resulting bending moment equation as:

$$M(x) = \iint \{ w[x-a]^0 - w[x-b]^0 \} dx = \frac{w}{2}[x-a]^2 - \frac{w}{2}[x-b]^2$$



## 1.5 Analysis Procedure

### Steps in Analysis

1. Draw a free body diagram of the member and take moments about the cut to obtain an equation for  $M(x)$ .
2. Equate  $M(x)$  to  $EI \frac{d^2y}{dx^2}$  - this is **Equation 1**.
3. Integrate Equation 1 to obtain an expression for the rotations along the beam,  $EI \frac{dy}{dx}$  - this is **Equation 2**, and has rotation constant of integration  $C_\theta$ .
4. Integrate Equation 2 to obtain an expression for the deflections along the beam,  $EIy$  - this is **Equation 3**, and has deflection constant of integration  $C_\delta$ .
5. Use known displacements at support points to calculate the unknown constants of integration, and any unknown reactions.
6. Substitute the calculated values into the previous equations:
  - a. Substitute for any unknown reactions;
  - b. Substitute the value for  $C_\theta$  into Equation 2, to give **Equation 4**;
  - c. Substitute the value for  $C_\delta$  into Equation 3, giving **Equation 5**.
7. Solve for required displacements by substituting the location into Equation 4 or 5 as appropriate.

Note that the constant of integration notation reflects the following:

- $C_\theta$  is the rotation where  $x = 0$ , i.e. the start of the beam;
- $C_\delta$  is the deflection where  $x = 0$ .

The constants of integration will always be in units of kN and m since we will keep our loads and distances in these units. Thus our final deflections will be in units of m, and our rotations in units of rads.

### Finding the Maximum Deflection

A usual problem is to find the maximum deflection. Given any curve  $y = f(x)$ , we know from calculus that  $y$  reaches a maximum at the location where  $\frac{dy}{dx} = 0$ . This is no different in our case where  $y$  is now deflection and  $\frac{dy}{dx}$  is the rotation. Therefore:

*A local maximum displacement occurs at a point of zero rotation*

The term local maximum indicates that there may be a few points on the deflected shape where there is zero rotation, or local maximum deflections. The overall biggest deflection will be the biggest of these local maxima. For example:

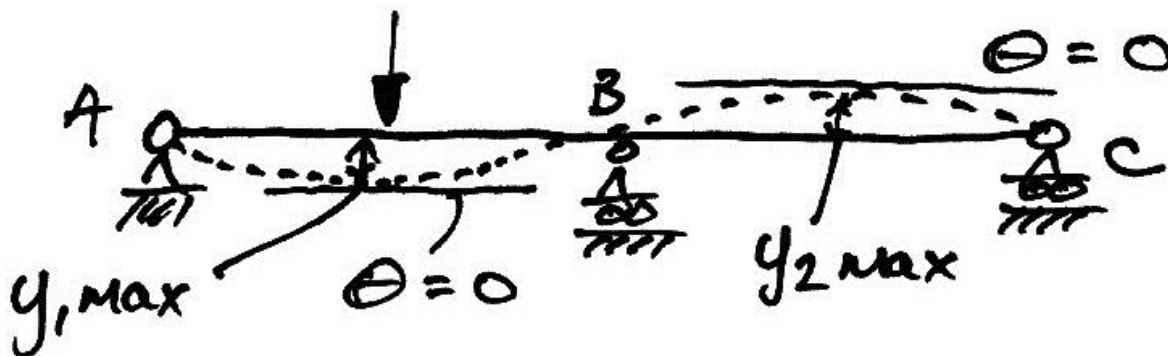

So in this beam we have  $\theta = 0$  at two locations, giving two local maximum deflections,  $y_{1,max}$  and  $y_{2,max}$ . The overall largest deflection is  $y_{max} = \max(y_{1,max}, y_{2,max})$ .

Lastly, to find the location of the maximum deflection we need to find where  $\theta = 0$ . Thus we need to solve the problem's Equation 4 to find an  $x$  that gives  $\theta = 0$ . Sometimes this can be done algebraically, but often it is done using trial and error. Once the  $x$  is found that gives  $\theta = 0$ , we know that this is also a local maximum deflection and so use this  $x$  in Equation 5 to find the local maximum deflection.

## Sign Convention

In Macaulay's Method, we will assume there to be tension on the bottom of the member by drawing our  $M(x)$  arrow coming from the bottom of the member. By doing this, we orient the  $x$ - $y$  axis system as normal: positive  $y$  upwards; positive  $x$  to the right; anti-clockwise rotations are positive – all as shown below. We do this even (e.g. a cantilever) where it is apparent that tension is on top of the beam. In this way, we know that downward deflections will always be algebraically negative.

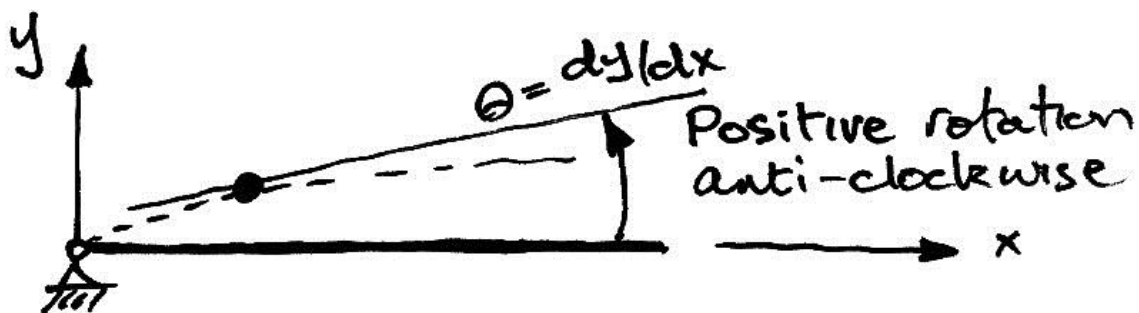
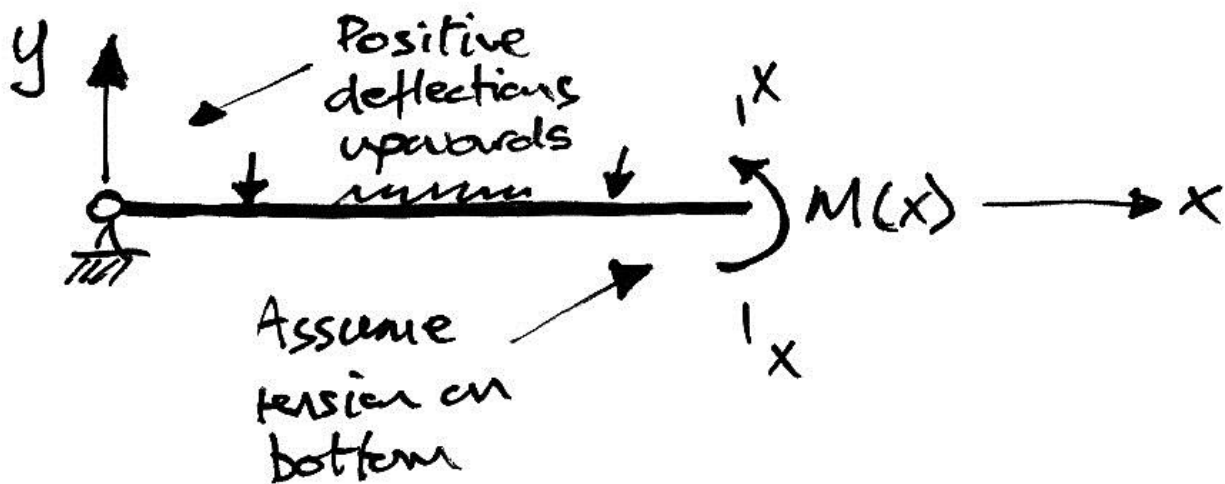

When it comes to frame members at an angle, we just imagine the above diagrams rotated to the angle of the member.

## 2. Determinate Beams

### 2.1 Example 1 – Point Load

#### Problem

For the beam looked at previously, calculate the rotations at the supports, show the maximum deflection is at midspan, and calculate the maximum deflection.

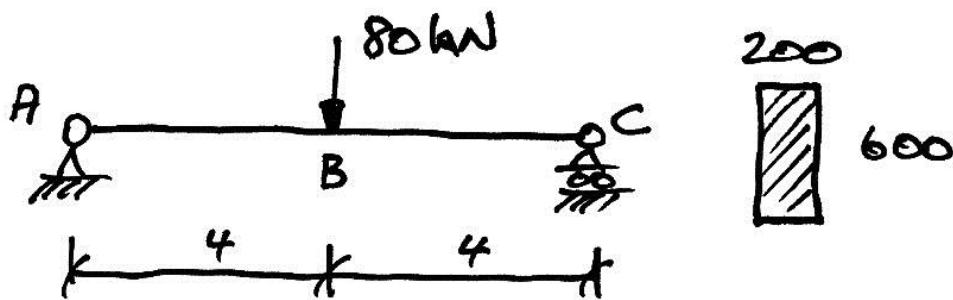

**Solution**

**Step 1**

The appropriate free-body diagram is:

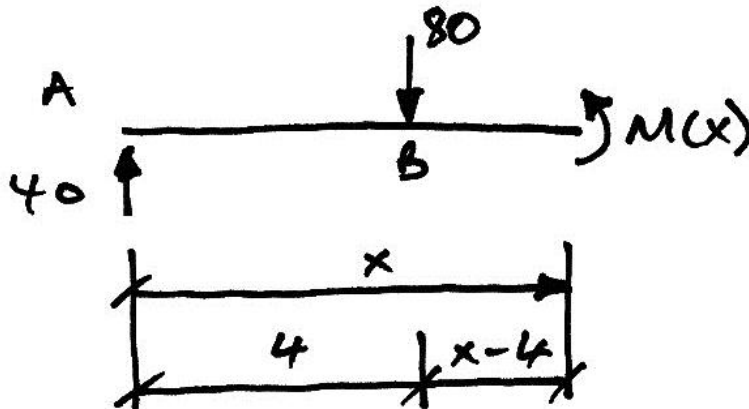

Note that in this diagram we have taken the cut so that all loading is accounted for.

Taking moments about the cut, we have:

$$M(x) - 40x + 80[x - 4] = 0$$

In which the Macaulay brackets have been used to indicate that when  $x \leq 4$  the term involving the 80 kN point load should become zero. Hence:

$$M(x) = 40x - 80[x - 4]$$

**Step 2**

Thus we write:

$$M(x) = EI \frac{d^2y}{dx^2} = 40x - 80[x - 4] \qquad \text{Equation 1}$$

### Step 3

Integrate Equation 1 to get:

$$EI \frac{dy}{dx} = \frac{40}{2}x^2 - \frac{80}{2}[x-4]^2 + C_\theta \quad \text{Equation 2}$$

### Step 4

Integrate Equation 2 to get:

$$EIy = \frac{40}{6}x^3 - \frac{80}{6}[x-4]^3 + C_\theta x + C_\delta \quad \text{Equation 3}$$

Notice that we haven't divided in by the denominators. This makes it easier to check for errors since, for example, we can follow the 40 kN reaction at A all the way through the calculation.

### Step 5

To determine the constants of integration we use the known displacements at the supports. That is:

- Support A: located at  $x = 0$ , deflection is zero, i.e.  $y = 0$ ;
- Support C: located at  $x = 8$ , deflection is zero, i.e.  $y = 0$ .

So, using Equation 3, for the first boundary condition,  $y = 0$  at  $x = 0$  gives:

$$EI(0) = \frac{40}{6}(0)^3 - \frac{80}{6}[0-4]^3 + C_\theta(0) + C_\delta$$

Impose the Macaulay bracket to get:

$$EI(0) = \frac{40}{6}(0)^3 - \frac{80}{6}[0-4]^3 + C_\theta(0) + C_\delta$$

$$0 = 0 - 0 + 0 + C_\delta$$

Therefore:

$$C_\delta = 0$$

Again using Equation 3 for the second boundary condition of  $y = 0$  at  $x = 8$  gives:

$$EI(0) = \frac{40}{6}(8)^3 - \frac{80}{6}[8-4]^3 + C_\theta(8) + 0$$

Since the term in the Macaulay brackets is positive, we keep its value. Note also that we have used the fact that we know  $C_\delta = 0$ . Thus:

$$0 = \frac{20480}{6} - \frac{5120}{6} + 8C_\theta$$

$$48C_\theta = -15360$$

$$C_\theta = -320$$

Which is in units of kN and m, as discussed previously.

### Step 6

Now with the constants known, we re-write Equations 2 & 3 to get Equations 4 & 5:

$$EI \frac{dy}{dx} = \frac{40}{2}x^2 - \frac{80}{2}[x-4]^2 - 320 \quad \text{Equation 4}$$

$$EIy = \frac{40}{6}x^3 - \frac{80}{6}[x-4]^3 - 320x \quad \text{Equation 5}$$

With Equations 4 & 5 found, we can now calculate any deformation of interest.

### Rotation at A

We are interested in  $\theta_A \equiv \frac{dy}{dx}$  at  $x=0$ . Thus, using Equation 4:

$$\begin{aligned} EI\theta_A &= \frac{40}{2}(0)^2 - \frac{80}{2}[0-4]^2 - 320 \\ EI\theta_A &= -320 \\ \theta_A &= \frac{-320}{EI} \end{aligned}$$

From before we have  $EI = 108 \times 10^3 \text{ kNm}^2$ , hence:

$$\theta_A = \frac{-320}{108 \times 10^3} = -0.003 \text{ rads}$$

The negative sign indicates a clockwise rotation at A as shown:



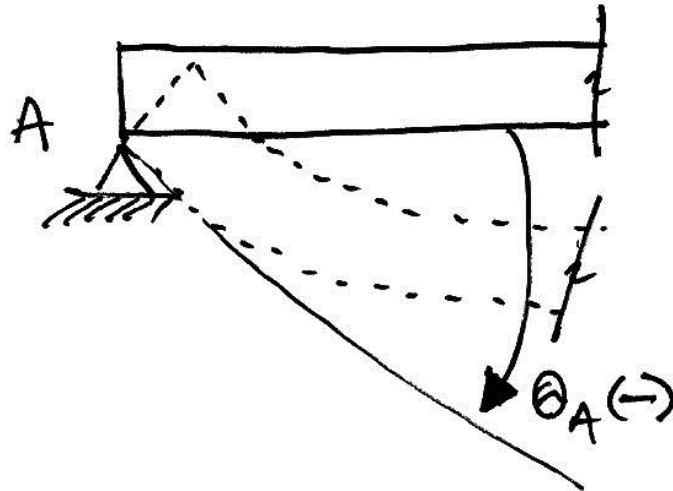

**Rotation at C**

We are interested in  $\theta_c \equiv \frac{dy}{dx}$  at  $x=8$ . Again, using Equation 4:

$$EI\theta_c = \frac{40}{2}(8)^2 - \frac{80}{2}[8-4]^2 - 320$$

$$EI\theta_c = 1280 - 640 - 320$$

$$\theta_c = \frac{+320}{EI}$$

$$= +0.003 \text{ rads}$$

So this rotation is equal, but opposite in sign, to the rotation at A, as shown:

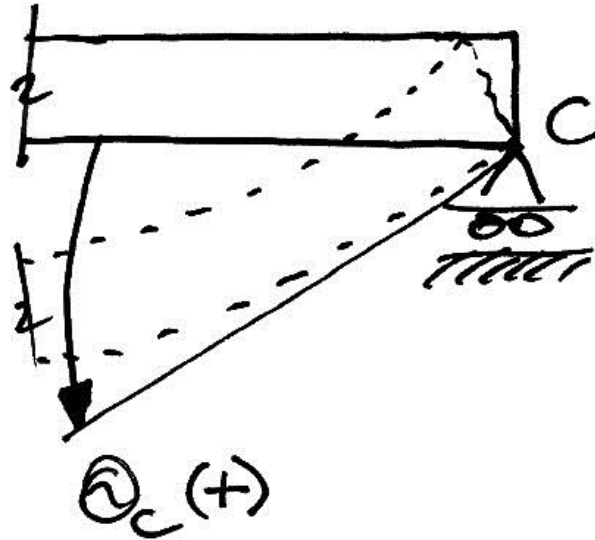

The rotations are thus symmetrical as is expected of a symmetrical beam symmetrically loaded.

### Location of Maximum Deflection

Since the rotations are symmetrical, we suspect that the maximum deflection is at the centre of the beam, but we will check this and not assume it. Thus we seek to confirm that the rotation at  $B$  (i.e.  $x = 4$ ) is zero. Using Equation 4:

$$EI\theta_B = \frac{40}{2}(4)^2 - \frac{80}{2}[4-4]^2 - 320$$

$$EI\theta_B = 320 - 0 - 320$$

$$\theta_B = 0$$

Therefore the maximum deflection does occur at midspan.

### Maximum Deflection

Substituting  $x = 4$ , the location of the zero rotation, into Equation 5:

$$EI\delta_B = \frac{40}{6}(4)^3 - \frac{80}{6}[4-4]^3 - 320(4)$$

$$EI\delta_B = \frac{2560}{6} - 0 - 1280$$

$$\delta_B = \frac{-853.33}{EI}$$

In which we have once again used the Macaulay bracket. Thus:

$$\delta_B = \frac{-853.33}{108 \times 10^3} = -7.9 \times 10^{-3} \text{ m}$$

$$= -7.9 \text{ mm}$$

Since the deflection is negative we know it to be downward as expected.

In summary then, the final displacements are:

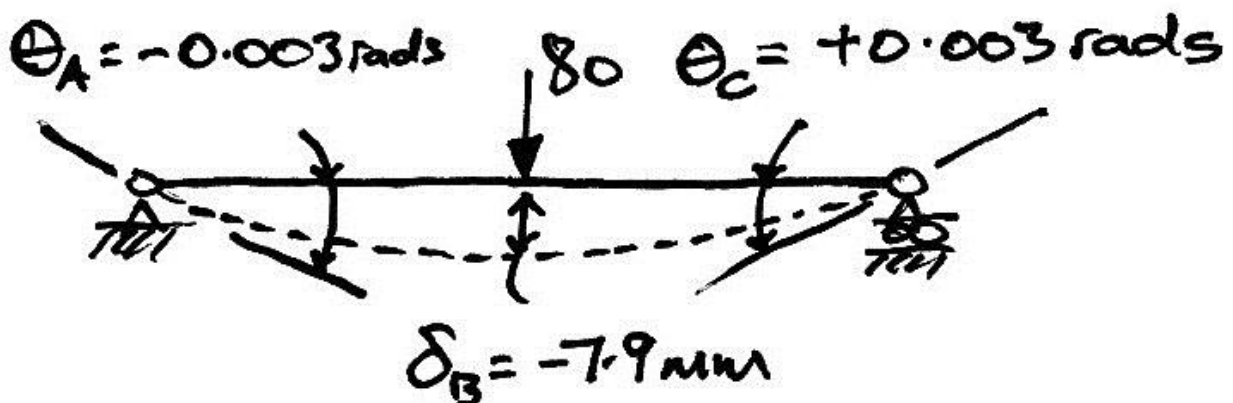

## 2.2 Example 2 – Patch Load

### Problem

In this example we take the same beam as before with the same load as before, except this time the 80 kN load will be spread over 4 m to give a UDL of 20 kN/m applied to the centre of the beam as shown:

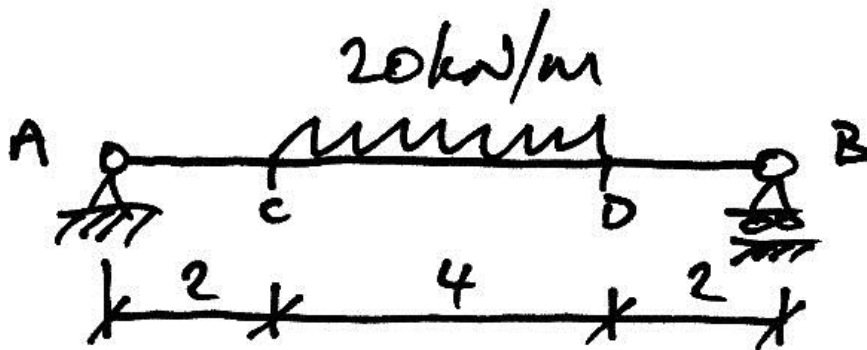



**Step 2**

Thus we write:

$$M(x) = EI \frac{d^2 y}{dx^2} = 40x - \frac{20}{2}[x-2]^2 + \frac{20}{2}[x-6]^2 \quad \text{Equation 1}$$

**Step 3**

Integrate Equation 1 to get:

$$EI \frac{dy}{dx} = \frac{40}{2}x^2 - \frac{20}{6}[x-2]^3 + \frac{20}{6}[x-6]^3 + C_\theta \quad \text{Equation 2}$$

**Step 4**

Integrate Equation 2 to get:

$$EIy = \frac{40}{6}x^3 - \frac{20}{24}[x-2]^4 + \frac{20}{24}[x-6]^4 + C_\theta x + C_\delta \quad \text{Equation 3}$$

As before, notice that we haven't divided in by the denominators.

**Step 5**

The boundary conditions are:

- Support A:  $y = 0$  at  $x = 0$ ;
- Support B:  $y = 0$  at  $x = 8$ .

So for the first boundary condition:

$$EI(0) = \frac{40}{6}(0)^3 - \frac{20}{24}[0-2]^4 + \frac{20}{24}[0-6]^4 + C_\theta(0) + C_\delta$$

$$C_\delta = 0$$

For the second boundary condition:

$$EI(0) = \frac{40}{6}(8)^3 - \frac{20}{24}(6)^4 + \frac{20}{24}(2)^4 + 8C_\theta$$

$$C_\theta = -293.33$$

### Step 6

Insert constants into Equations 2 & 3:

$$EI \frac{dy}{dx} = \frac{40}{2}x^2 - \frac{20}{6}[x-2]^3 + \frac{20}{6}[x-6]^3 - 293.33 \quad \text{Equation 4}$$

$$EIy = \frac{40}{6}x^3 - \frac{20}{24}[x-2]^4 + \frac{20}{24}[x-6]^4 - 293.33x \quad \text{Equation 5}$$

To compare the effect of smearing the 80 kN load over 4 m rather than having it concentrated at midspan, we calculate the midspan deflection:

$$EI\delta_{\max} = \frac{40}{6}(4)^3 - \frac{20}{24}(2)^4 + \frac{20}{24}[4-6]^4 - 293.33(4)$$

$$= -760$$

Therefore:

$$\delta_{\max} = \frac{-760}{EI} = \frac{-760}{108 \times 20^3} = -0.00704 \text{ m}$$

$$\delta_{\max} = -7.04 \text{ mm}$$

This is therefore a downward deflection as expected. Comparing it to the 7.9 mm deflection for the 80 kN point load, we see that smearing the load has reduced deflection, as may be expected.

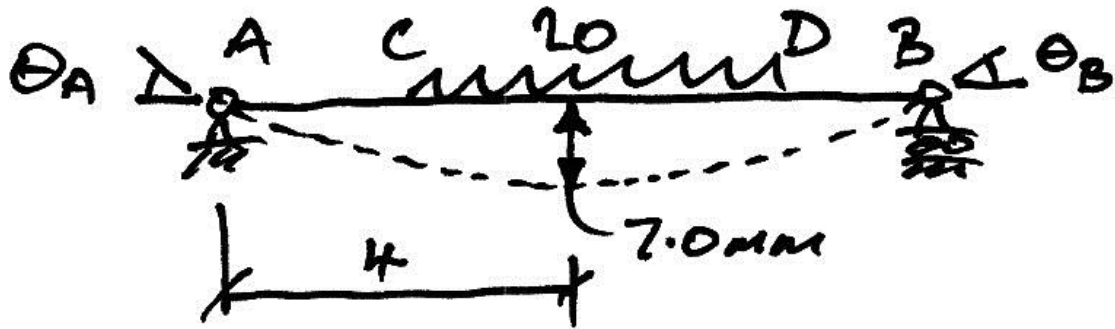

**Problem:**

- Verify that the maximum deflection occurs at the centre of the beam;
- Calculate the end rotations.



### 2.3 Example 3 – Moment Load

#### Problem

For this example we take the same beam again, except this time it is loaded by a moment load at midspan, as shown:

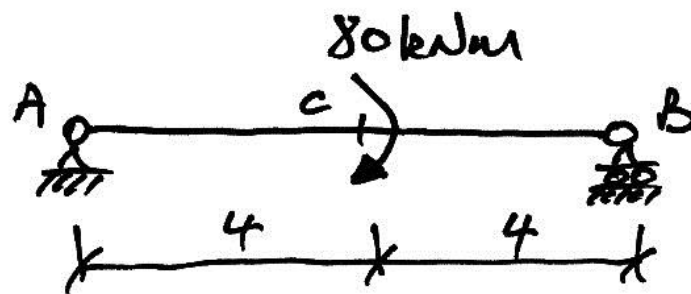

**Solution**

Before beginning Macaulay's Method, we need to calculate the reactions:

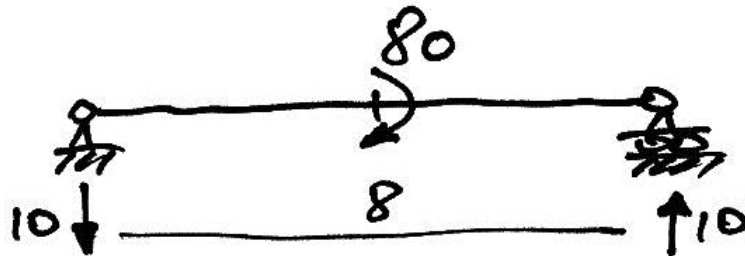

**Step 1**

The free-body diagram is:

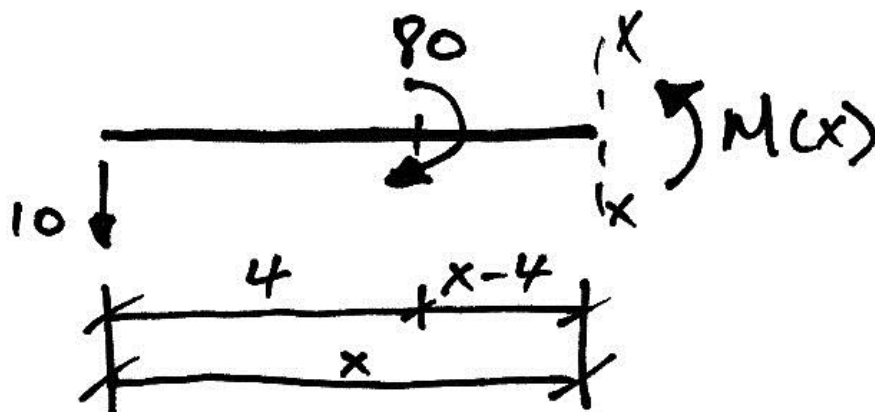

Taking moments about the cut, we have:

$$M(x) + 10x - 80[x - 4]^0 = 0$$

Notice a special point here. We have used our knowledge of the singularity function representation of a moment load to essentially locate the moment load at  $x = 4$  in the equations above. Refer back to page 22 to see why this is done. Continuing:

$$M(x) = -10x + 80[x - 4]^0$$

**Step 2**

$$M(x) = EI \frac{d^2 y}{dx^2} = -10x + 80[x - 4]^0 \quad \text{Equation 1}$$

**Step 3**

$$EI \frac{dy}{dx} = -\frac{10}{2}x^2 + 80[x - 4]^1 + C_\theta \quad \text{Equation 2}$$

**Step 4**

$$EI y = -\frac{10}{6}x^3 + \frac{80}{2}[x - 4]^2 + C_\theta x + C_\delta \quad \text{Equation 3}$$

**Step 5**

We know  $y = 0$  at  $x = 0$ , thus:

$$EI(0) = -\frac{10}{6}(0)^3 + \frac{80}{2}[0 - 4]^2 + C_\theta(0) + C_\delta$$

$$C_\delta = 0$$

$y = 0$  at  $x = 8$ , thus:

$$EI(0) = -\frac{10}{6}(8)^3 + \frac{80}{2}(4)^2 + 8C_\theta$$

$$C_\theta = +\frac{80}{3}$$

**Step 6**

$$EI \frac{dy}{dx} = -\frac{10}{2}x^2 + 80[x - 4]^1 + \frac{80}{3} \quad \text{Equation 4}$$

$$EIy = -\frac{10}{6}x^3 + \frac{80}{2}[x-4]^2 + \frac{80}{3}x$$

Equation 5

So for the deflection at C:

$$EI\delta_c = -\frac{10}{6}(4)^3 + \frac{80}{2}[4-4]^2 + \frac{80}{3}(4)$$

$$EI\delta_c = 0$$

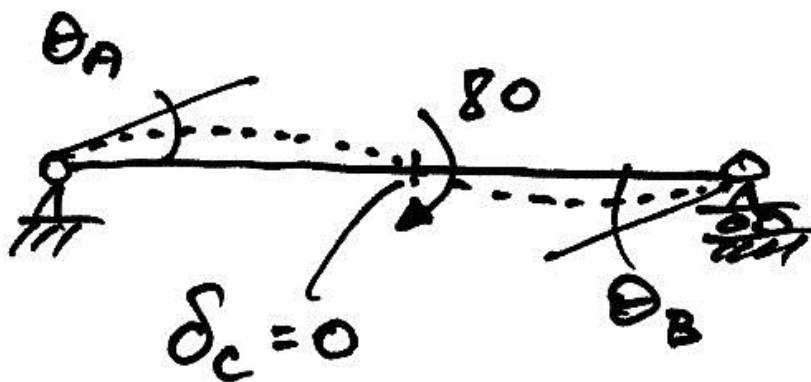

**Problem:**

- Verify that the rotation at A and B are equal in magnitude and sense;
- Find the location and value of the maximum deflection.

**2.4 Example 4 – Beam with Overhangs and Multiple Loads**

**Problem**

For the following beam, determine the maximum deflection, taking  $EI = 20 \times 10^3 \text{ kNm}^2$ :

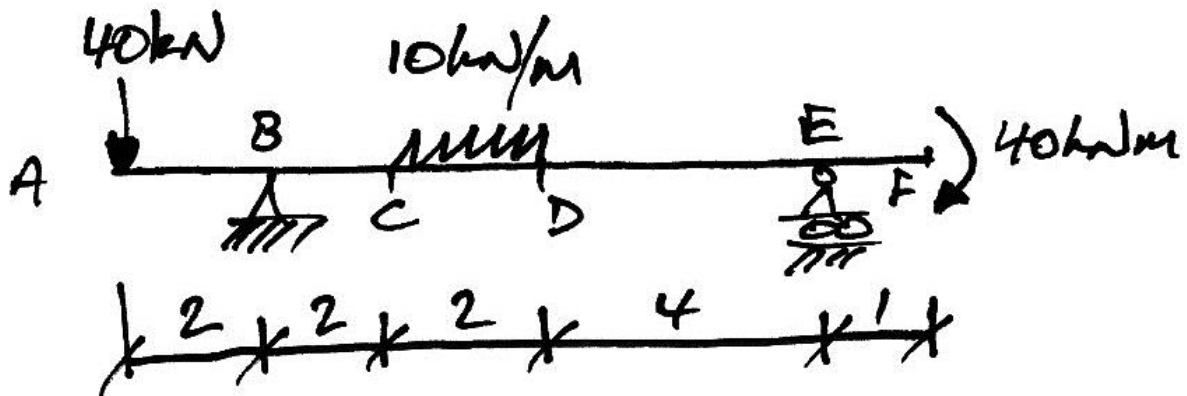

**Solution**

As always, before beginning Macaulay's Method, we need to calculate the reactions:

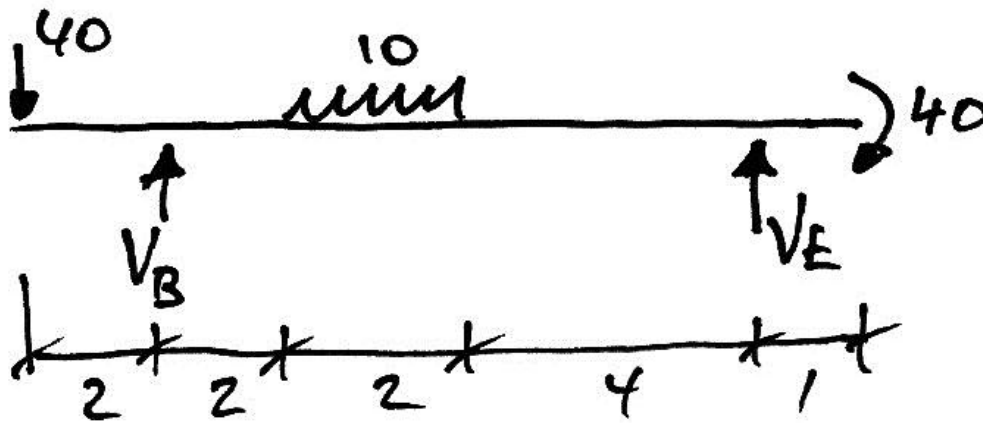

Taking moments about  $B$ :

$$-(40 \cdot 2) + \left\{ (10 \cdot 2) \cdot \left( \frac{2}{2} + 2 \right) \right\} - 8V_E + 40 = 0$$

$$V_E = +2.5 \text{ kN i.e. } \uparrow$$

Summing vertical forces:

$$V_B + 2.5 - 40 - (2 \cdot 10) = 0$$

$$V_B = +57.5 \text{ kN, i.e. } \uparrow$$

With the reactions calculated, we begin by drawing the free body diagram for Macaulay's Method:

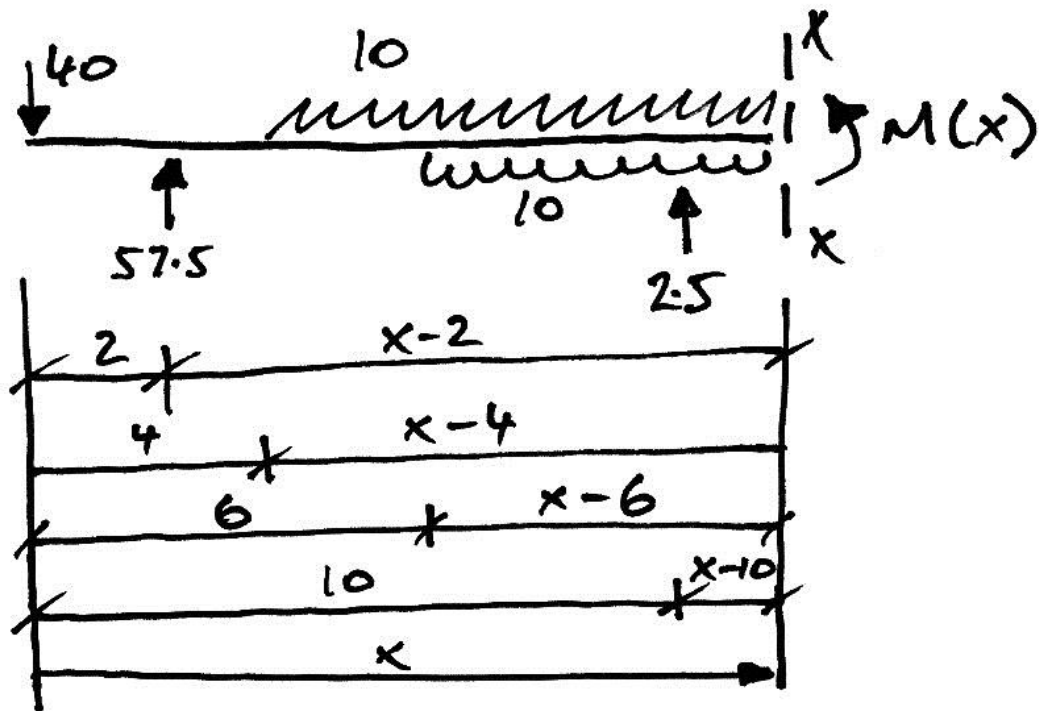

Note the following points:

- The patch load has been extended all the way to the end of the beam and a cancelling load has been applied from  $D$  onwards;
- The cut has been taken so that all forces applied to the beam are to the left of the cut. Though the 40 kNm moment is to the right of the cut, and so not in the diagram, its effect is accounted for in the reactions which are included.

Taking moments about the cut:

$$M(x) + 40x - 57.5[x - 2] + \frac{10}{2}[x - 4]^2 - \frac{10}{2}[x - 6]^2 - 2.5[x - 10] = 0$$

So we have **Equation 1**:

$$M(x) = EI \frac{d^2 y}{dx^2} = -40x + 57.5[x - 2] - \frac{10}{2}[x - 4]^2 + \frac{10}{2}[x - 6]^2 + 2.5[x - 10]$$

Integrate for **Equation 2**:

$$EI \frac{dy}{dx} = -\frac{40}{2}x^2 + \frac{57.5}{2}[x-2]^2 - \frac{10}{6}[x-4]^3 + \frac{10}{6}[x-6]^3 + \frac{2.5}{2}[x-10]^2 + C_\theta$$

And again for **Equation 3**:

$$EIy = -\frac{40}{6}x^3 + \frac{57.5}{6}[x-2]^3 - \frac{10}{24}[x-4]^4 + \frac{10}{24}[x-6]^4 + \frac{2.5}{6}[x-10]^3 + C_\theta x + C_\delta$$

Using the boundary condition at support *B* where  $y=0$  at  $x=2$ :

$$EI(0) = -\frac{40}{6}(2)^3 + \frac{57.5}{6}[2-2]^3 - \frac{10}{24}[2-4]^4 + \frac{10}{24}[2-6]^4 + \frac{2.5}{6}[2-10]^3 + 2C_\theta + C_\delta$$

Thus:

$$2C_\theta + C_\delta = \frac{160}{3} \quad \text{(a)}$$

The second boundary condition is  $y=0$  at  $x=10$ :

$$EI(0) = -\frac{40}{6}(10)^3 + \frac{57.5}{6}(8)^3 - \frac{10}{24}(6)^4 + \frac{10}{24}(4)^4 + \frac{2.5}{6}[10-10]^3 + 10C_\theta + C_\delta$$

Hence:



$$10C_{\theta} + C_{\delta} = \frac{6580}{3} \quad (\text{b})$$

Subtracting (a) from (b) gives:

$$8C_{\theta} = \frac{6420}{3} \quad \Rightarrow C_{\theta} = +267.5$$

And:

$$2(267.5) + C_{\delta} = \frac{160}{3} \quad \Rightarrow C_{\delta} = -481.7$$

Thus we have **Equation 4**:

$$EI \frac{dy}{dx} = -\frac{40}{2}x^2 + \frac{57.5}{2}[x-2]^2 - \frac{10}{6}[x-4]^3 + \frac{10}{6}[x-6]^3 + \frac{2.5}{2}[x-10]^2 + 267.5$$

And **Equation 5**:

$$EIy = -\frac{40}{6}x^3 + \frac{57.5}{6}[x-2]^3 - \frac{10}{24}[x-4]^4 + \frac{10}{24}[x-6]^4 + \frac{2.5}{6}[x-10]^3 + 267.5x - 481.7$$

Since we are interested in finding the maximum deflection, we solve for the shear, bending moment, and deflected shape diagrams, in order to better visualize the beam's behaviour:

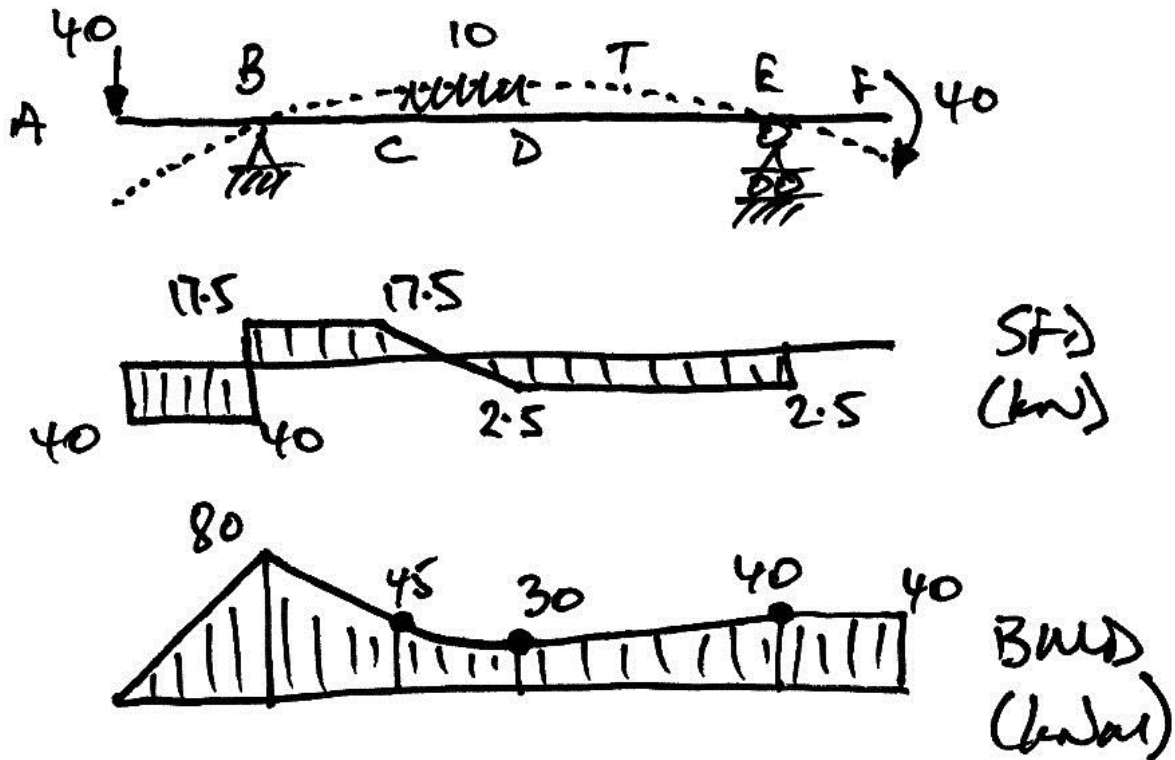

So examining the above, the overall maximum deflection will be the biggest of:

1.  $\delta_A$  - the deflection of the tip of the cantilever at A – found from Equation 5 using  $x=0$ ;
2.  $\delta_F$  - the deflection of the tip of the cantilever at F – again got from Equation 5 using  $x=11$ ;
3.  $\delta_{\max}|BE|$  - the largest upward deflection somewhere between the supports – its location is found solving Equation 4 to find the  $x$  where  $\theta=0$ , and then substituting this value into Equation 5.

**Maximum Deflection Between  $B$  and  $E$**

Since Equation 4 cannot be solved algebraically for  $x$ , we will use trial and error.

Initially choose the midspan, where  $x = 6$ :

$$EI \frac{dy}{dx} \Big|_{x=6} = -\frac{40}{2}(6)^2 + \frac{57.5}{2}(4)^2 - \frac{10}{6}(2)^3 + \frac{10}{6}[6-6]^3 + \frac{2.5}{2}[6-10]^2 + 267.5$$

$$= -5.83$$

Try reducing  $x$  to get closer to zero, say  $x = 5.8$ :

$$EI \frac{dy}{dx} \Big|_{x=5.8} = -\frac{40}{2}(5.8)^2 + \frac{57.5}{2}(3.8)^2 - \frac{10}{6}(1.8)^3 + \frac{10}{6}[5.8-6]^3 + \frac{2.5}{2}[5.8-10]^2 + 267.5$$

$$= +0.13$$

Since the sign of the rotation has changed, zero rotation occurs between  $x = 5.8$  and  $x = 6$ . But it is apparent that zero rotation occurs close to  $x = 5.8$ . Therefore, we will use  $x = 5.8$  since it is close enough (you can check this by linearly interpolating between the values).

So, using  $x = 5.8$ , from Equation 5 we have:

$$EI \delta_{\max} |BE| = -\frac{40}{6}(5.8)^3 + \frac{57.5}{6}(3.8)^3 - \frac{10}{24}(1.8)^4 + \frac{10}{24}[5.8-6]^4 + \frac{2.5}{6}[5.8-10]^3$$

$$+ 267.5(5.8) - 481.7$$

$$EI \delta_{\max} |BE| = +290.5$$

Thus we have:

$$\begin{aligned}\delta_{\max} |BE| &= +\frac{290.5}{EI} = +\frac{290.5}{20 \times 10^3} = +0.01453 \text{ m} \\ &= +14.53 \text{ mm}\end{aligned}$$

Since the result is positive it represents an upward deflection.

### Deflection at A

Substituting  $x=0$  into Equation 5 gives:

$$\begin{aligned}EI\delta_A &= -\frac{40}{6}(0)^3 + \frac{57.5}{6}[0-2]^3 - \frac{10}{24}[0-4]^4 + \frac{10}{24}[0-6]^4 + \frac{2.5}{6}[0-10]^3 \\ &\quad + 267.5(0) - 481.7 \\ EI\delta_A &= -481.7\end{aligned}$$

Hence

$$\begin{aligned}\delta_A &= -\frac{481.7}{EI} = -\frac{481.7}{20 \times 10^3} = -0.02409 \text{ m} \\ &= -24.09 \text{ mm}\end{aligned}$$

Since the result is negative the deflection is downward. Note also that the deflection at A is the same as the deflection constant of integration,  $C_s$ . This is as mentioned previously on page 25.

### Deflection at F

Substituting  $x=11$  into Equation 5 gives:

$$\begin{aligned}EI\delta_F &= -\frac{40}{6}(11)^3 + \frac{57.5}{6}(9)^3 - \frac{10}{24}(7)^4 + \frac{10}{24}(5)^4 + \frac{2.5}{6}(1)^3 \\ &\quad + 267.5(11) - 481.7 \\ EI\delta_F &= -165.9\end{aligned}$$

Giving:

$$\begin{aligned}\delta_F &= -\frac{165.9}{EI} = -\frac{165.9}{20 \times 10^3} = -0.00830 \text{ m} \\ &= -8.30 \text{ mm}\end{aligned}$$

Again the negative result indicates the deflection is downward.

### Maximum Overall Deflection

The largest deviation from zero anywhere in the beam is thus at A, and so the maximum deflection is 24.09 mm, as shown:

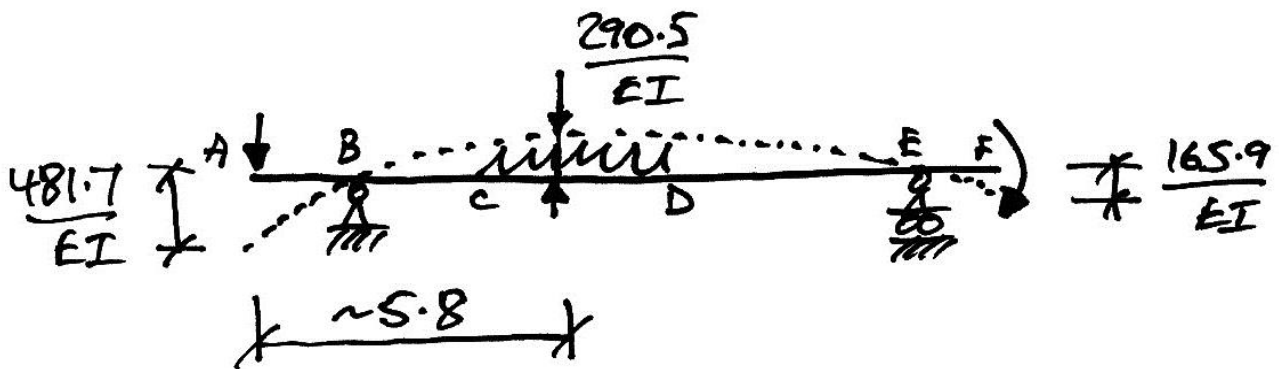

### 2.5 Example 5 – Beam with Hinge

#### Problem

For the following prismatic beam, find the following:

- The rotations at the hinge;
- The deflection of the hinge;
- The maximum deflection in span  $BE$ .

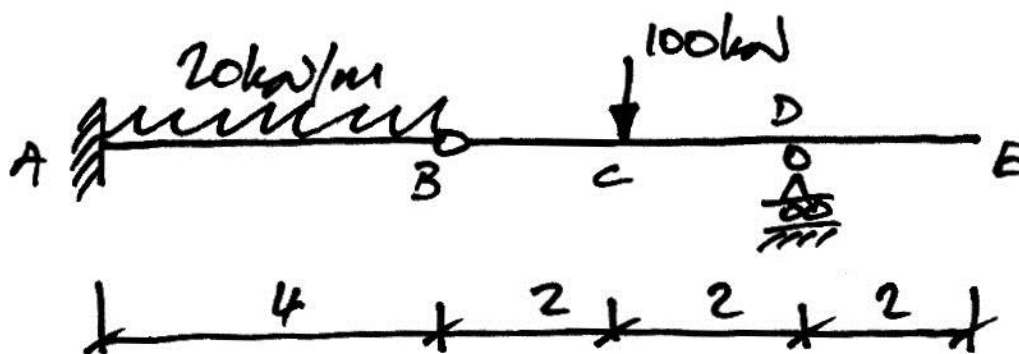

**Solution**

Calculate the reactions first:

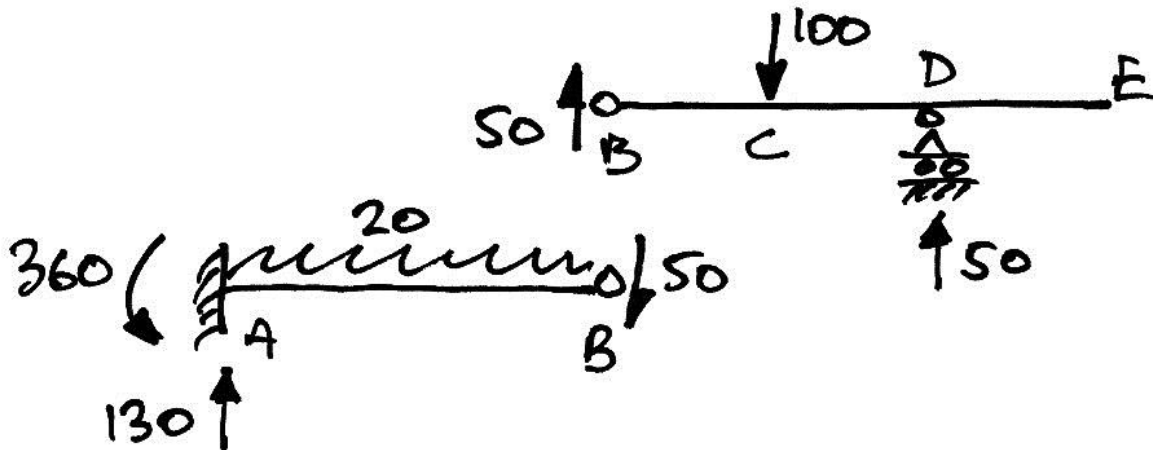

This beam is made of two members:  $AB$  and  $BE$ . The Euler-Bernoulli deflection equation only applies to individual members, and does not apply to the full beam  $AB$  since there is a discontinuity at the hinge,  $B$ . The discontinuity occurs in the rotations at  $B$ , since the ends of members  $AB$  and  $BE$  have different slopes as they connect to the hinge. However, there is also compatibility of displacement at the hinge in that the deflection of members  $AB$  and  $BE$  must be the same at  $B$  – there is only one vertical deflection at the hinge. From the previous examples we know that each member will have two constants of integration, and thus, for this problem, there will be four constants in total. However, we have the following knowns:

- Deflection at  $A$  is zero;
- Rotation at  $A$  is zero;
- Deflection at  $D$  is zero;
- Deflection at  $B$  is the same for members  $AB$  and  $BE$ ;

Thus we can solve for the four constants and the problem as a whole. To proceed we consider each span separately initially.

**Span AB**

The free-body diagram for the deflection equation is:

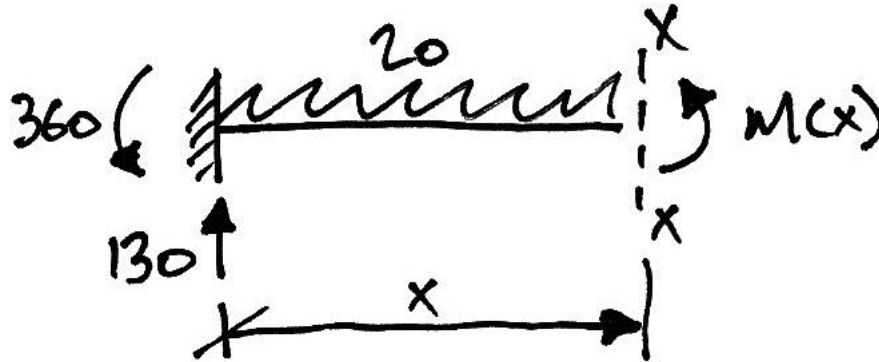

Note that even though it is apparent that there will be tension on the top of the cantilever, we have retained our sign convention by taking  $M(x)$  as tension on the bottom. Taking moments about the cut:

$$M(x) + 360 - 130x + \frac{20}{2}x^2 = 0$$

Hence, the calculations proceed as:

$$M(x) = EI \frac{d^2 y}{dx^2} = 130x - 360 - \frac{20}{2}x^2 \quad \text{Equation (AB)1}$$

$$EI \frac{dy}{dx} = \frac{130}{2}x^2 - 360x - \frac{20}{6}x^3 + C_\theta \quad \text{Equation (AB)2}$$

$$EIy = \frac{130}{6}x^3 - \frac{360}{2}x^2 - \frac{20}{24}x^4 + C_\theta x + C_\delta \quad \text{Equation (AB)3}$$

At  $x=0$ ,  $y=0$ :



$$EI(0) = \frac{130}{6}(0)^3 - \frac{360}{2}(0)^2 - \frac{20}{24}(0)^4 + C_\theta(0) + C_\delta \Rightarrow C_\delta = 0$$

At  $x=0$ ,  $\theta_A = \frac{dy}{dx} = 0$ :

$$EI(0) = \frac{130}{2}(0)^2 - 360(0) - \frac{20}{6}(0)^3 + C_\theta \Rightarrow C_\theta = 0$$

Thus the final equations are:

$$EI \frac{dy}{dx} = \frac{130}{2}x^2 - 360x - \frac{20}{6}x^3 \quad \text{Equation (AB)4}$$

$$EIy = \frac{130}{6}x^3 - \frac{360}{2}x^2 - \frac{20}{24}x^4 \quad \text{Equation (AB)5}$$

### Span BE

The relevant free-body diagram is:

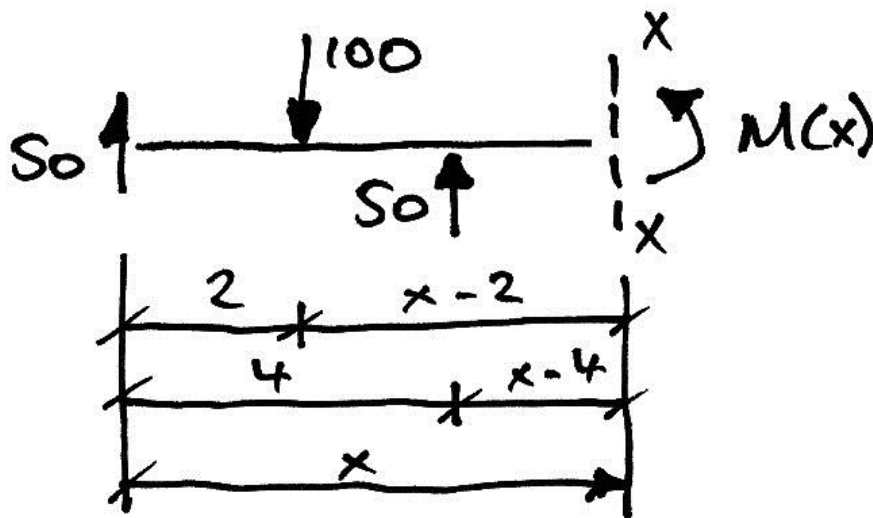

Thus:

$$M(x) + 100[x - 2] - 50x - 50[x - 4] = 0$$

$$M(x) = EI \frac{d^2 y}{dx^2} = 50x + 50[x - 4] - 100[x - 2] \quad \text{Equation (BE)1}$$

$$EI \frac{dy}{dx} = \frac{50}{2}x^2 + \frac{50}{2}[x - 4]^2 - \frac{100}{2}[x - 2]^2 + C_\theta \quad \text{Equation (BE)2}$$

$$EIy = \frac{50}{6}x^3 + \frac{50}{6}[x - 4]^3 - \frac{100}{6}[x - 2]^3 + C_\theta x + C_\delta \quad \text{Equation (BE)3}$$

At this point in a more typical analysis we would calculate the constants of integration. However, since we know the constants to be the starting deflection and rotation (at  $x = 0$ ), or since we know we have only one known for member BE (the deflection at D), and since we do not yet have these for point B (the hinge), we cannot yet determine these constants. We must first determine the deflection at B from member AB's Equation (AB)5. Thus:

$$EI\delta_B = \frac{130}{6}(4)^3 - \frac{360}{2}(4)^2 - \frac{20}{24}(4)^4$$

$$\delta_B = \frac{-1707}{EI}$$

This is a downward deflection and must also be the deflection at B for member BE, so from Equation (BE)3:

$$EI \left( \frac{-1707}{EI} \right) = \frac{50}{6}(0)^3 + \frac{50}{6}[0-4]^3 - \frac{100}{6}[0-2]^3 + C_\theta(0) + C_\delta$$

$$C_\delta = -1707$$

Notice that again we find the deflection constant of integration to be the value of deflection at the start of the member.

Representing the deflection at support  $D$ , we know that at  $x=4$ ,  $y=0$  for member  $BE$ . Thus using Equation (BE)3 again:

$$EI(0) = \frac{50}{6}(4)^3 + \frac{50}{6}[4-4]^3 - \frac{100}{6}(2)^3 + C_\theta(4) - 1707$$

$$C_\theta = +327$$

Giving **Equation (BE)4** and **Equation (BE)5** respectively as:

$$EI \frac{dy}{dx} = \frac{50}{2}x^2 + \frac{50}{2}[x-4]^2 - \frac{100}{2}[x-2]^2 + 327$$

$$EIy = \frac{50}{6}x^3 + \frac{50}{6}[x-4]^3 - \frac{100}{6}[x-2]^3 + 327x - 1707$$

### Rotation at $B$ for Member $AB$

Using Equation (AB)4:

$$EI\theta_{BA} = \frac{130}{2}(4)^2 - 360(4) - \frac{20}{6}(4)^3$$

$$\theta_{BA} = \frac{-613}{EI}$$

The negative sign indicates an anticlockwise movement from the  $x$ -axis:

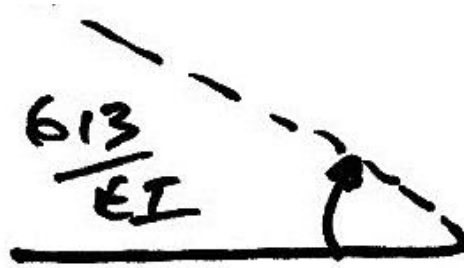

**Rotation at  $B$  for Member  $BE$**

Using Equation (BE)4:

$$EI\theta_{BE} = \frac{50}{2}(0)^2 + \frac{50}{2}[0-4]^2 - \frac{100}{2}[0-2]^2 + 327$$

$$\theta_{BE} = \frac{+327}{EI}$$

Again the constant of integration is the starting displacement of the member. The positive sign indicates clockwise movement from the  $x$ -axis:



Thus at  $B$  the deflected shape is:

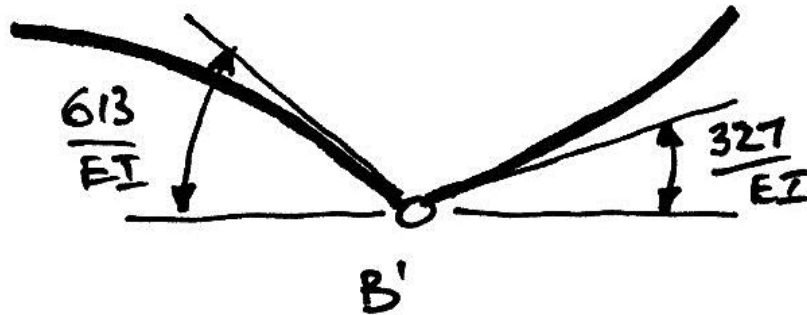

### Deflection at $B$

Calculated previously to be  $\delta_B = -1707/EI$ .

### Maximum Deflection in Member $BE$

There are three possibilities:

- The maximum deflection is at  $B$  – already known;
- The maximum deflection is at  $E$  – to be found;
- The maximum deflection is between  $B$  and  $D$  – to be found.

The deflection at  $E$  is got from Equation (BE)5:

$$EI\delta_E = \frac{50}{6}(6)^3 + \frac{50}{6}(2)^3 - \frac{100}{6}(4)^3 + 327(6) - 1707$$

$$\delta_E = \frac{+1055}{EI}$$

And this is an upwards displacement which is smaller than that of the movement at  $B$ .

To find the maximum deflection between  $B$  and  $D$ , we must identify the position of zero rotation. Since at the start of the member (i.e. at  $B$ ) we know the rotation is positive ( $\theta_{BE} = +327/EI$ ), zero rotation can only occur in between if the rotation at the other end of the member (rotation at  $E$ ) is negative. However, we know the rotation at  $E$  is the same as that at  $D$  since  $DE$  is straight because there is no bending

in it. Hence we can find the rotation at  $D$  or  $E$  to see if it is negative. We choose  $D$ , since there will be fewer terms due to the Macaulay bracket; from Equation (BE)4:

$$EI\theta_D = \frac{50}{2}(4)^2 + \frac{50}{2}[4-4]^2 - \frac{100}{2}(2)^2 + 327$$

$$\theta_D = \frac{+527}{EI}$$

Since this is positive, there is no point at which zero rotation occurs between  $B$  and  $D$  and thus there is no position of maximum deflection. Therefore the largest deflections occur at the ends of the member, and are as calculated previously:

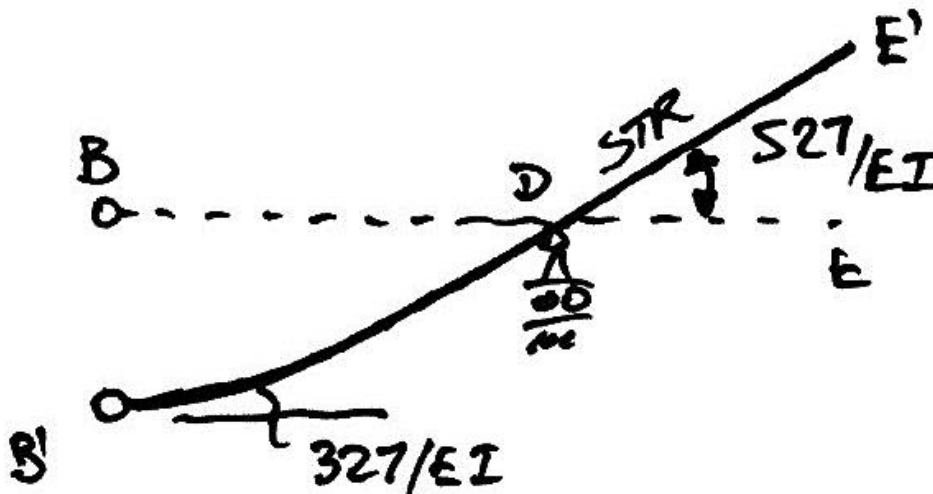

As a mathematical check on our structural reasoning above, we attempt to solve

Equation (BE)4 for  $x$  when  $\frac{dy}{dx} = 0$ :

$$EI(0) = \frac{50}{2}x^2 + \frac{50}{2}[x-4]^2 - \frac{100}{2}[x-2]^2 + 327$$

$$0 = \frac{50}{2}x^2 + \frac{50}{2}[x^2 - 8x + 16] - \frac{100}{2}[x^2 - 4x + 4] + 327$$

Collecting terms, we have:

$$0 = \left( \frac{50}{2} + \frac{50}{2} - \frac{100}{2} \right) x^2 + \left( \frac{-400}{2} + \frac{400}{2} \right) x + \left( \frac{800}{2} - \frac{400}{2} + 327 \right)$$

$$0 = (0)x^2 + (0)x + 527$$

$$0 = 527$$

Since this is not possible, there is no solution to the above problem. That is, there is no position  $x$  at which  $\frac{dy}{dx} = 0$ , and thus there is no maximum deflection between  $B$  and  $D$ . Thus the largest movement of member  $BE$  is the deflection at  $B$ ,  $-1707/EI$ :

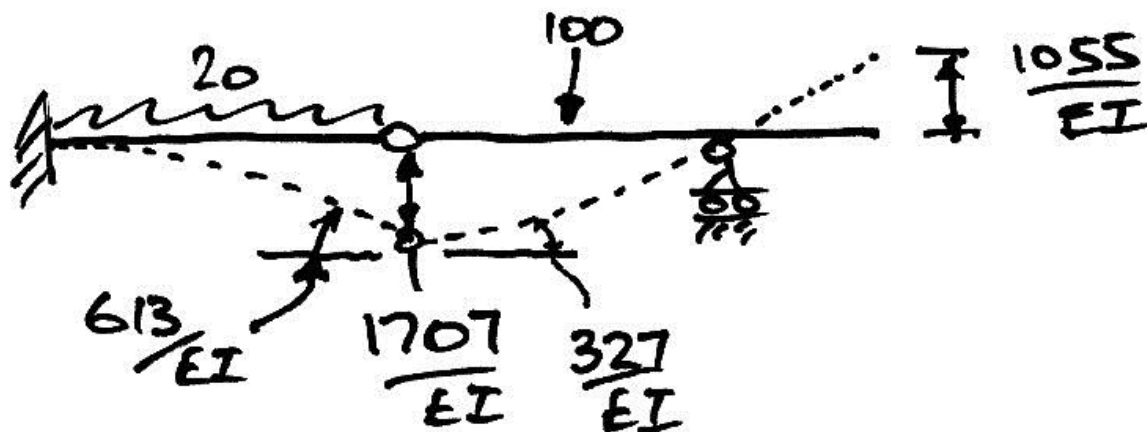

As an aside, we can check our calculation for the deflection at  $E$  using the  $S = R\theta$  rule for small displacements. Thus:

$$\delta_E = 2 \cdot \frac{527}{EI} = \frac{1054}{EI}$$

Which is very close to the previous result of  $1055/EI$ .

This solution has been put into Excel to give plots of the deflected shape, as follows:

**Macaulay's Method - Determinate Beam with Hinge**

X global	X for AB	X for BE	dy/dx AB	y AB	dy/dx BE	y BE
0.00	0.00	-4.00	0.0	0.0	727.0	-3548.3
0.25	0.25	-3.75	-86.0	-10.9	678.6	-3372.7
0.50	0.50	-3.50	-164.2	-42.3	633.3	-3208.8
0.75	0.75	-3.25	-234.8	-92.4	591.1	-3055.8
1.00	1.00	-3.00	-298.3	-159.2	552.0	-2913.0
1.25	1.25	-2.75	-354.9	-241.0	516.1	-2779.6
1.50	1.50	-2.50	-405.0	-336.1	483.3	-2654.7
1.75	1.75	-2.25	-448.8	-442.9	453.6	-2537.7
2.00	2.00	-2.00	-486.7	-560.0	427.0	-2427.7
2.25	2.25	-1.75	-518.9	-685.8	403.6	-2323.9
2.50	2.50	-1.50	-545.8	-819.0	383.3	-2225.6
2.75	2.75	-1.25	-567.8	-958.3	366.1	-2132.0
3.00	3.00	-1.00	-585.0	-1102.5	352.0	-2042.3
3.25	3.25	-0.75	-597.9	-1250.4	341.1	-1955.8
3.50	3.50	-0.50	-606.7	-1401.1	333.3	-1871.5
3.75	3.75	-0.25	-611.7	-1553.5	328.6	-1788.9
4.00	4.00	0.00	-613.3	-1706.7	327.0	-1707.0
4.25		0.25			328.6	-1625.1
4.50		0.50			333.3	-1542.5
4.75		0.75			341.1	-1458.2
5.00		1.00			352.0	-1371.7
5.25		1.25			366.1	-1282.0
5.50		1.50			383.3	-1188.4
5.75		1.75			403.6	-1090.1
6.00		2.00			427.0	-986.3
6.25		2.25			450.4	-876.6
6.50		2.50			470.8	-761.4
6.75		2.75			487.9	-641.5
7.00		3.00			502.0	-517.7
7.25		3.25			512.9	-390.7
7.50		3.50			520.8	-261.5
7.75		3.75			525.4	-130.6
8.00		4.00			527.0	1.0
8.25		4.25			527.0	132.8
8.50		4.50			527.0	264.5
8.75		4.75			527.0	396.3
9.00		5.00			527.0	528.0
9.25		5.25			527.0	659.8
9.50		5.50			527.0	791.5
9.75		5.75			527.0	923.3
10.00		6.00			527.0	1055.0

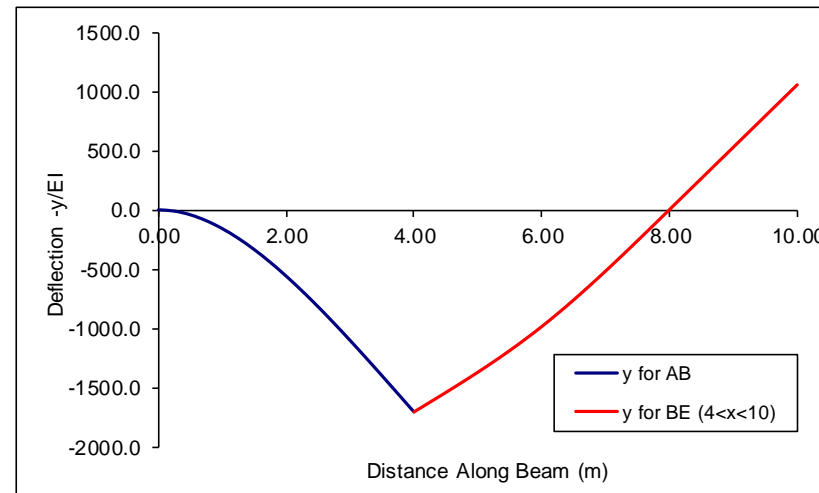
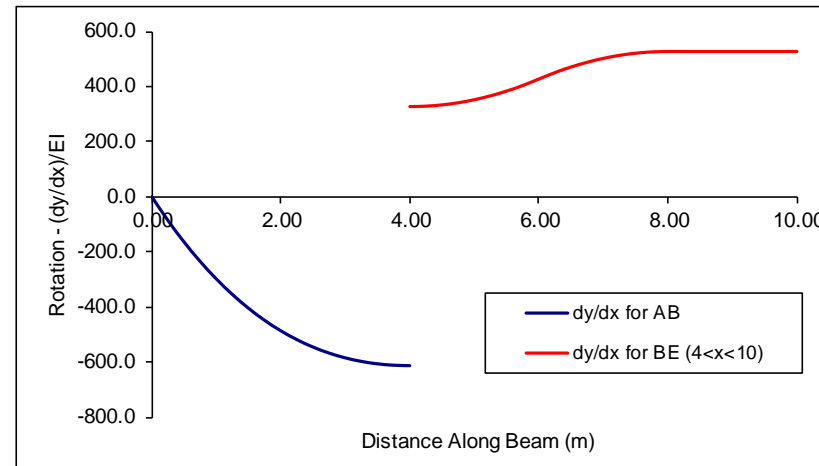

**Equation used in the Cells**

$$dy/dx \text{ AB} = 130 \cdot x^2/2 - 360 \cdot x - 20 \cdot x^3/6$$

$$y \text{ AB} = 130 \cdot x^3/6 - 360 \cdot x^2/2 - 20 \cdot x^4/24$$

$$dy/dx \text{ BE} = 50 \cdot x^2/2 + 50 \cdot \text{MAX}(x-4, 0)^2/2 - 100 \cdot \text{MAX}(x-2, 0)^2/2 + 327$$

$$y \text{ BE} = 50 \cdot x^3/6 + 50 \cdot \text{MAX}(x-4, 0)^3/6 - 100 \cdot \text{MAX}(x-2, 0)^3/6 + 327 \cdot x - 1707$$



**2.6 Problems**

1. (DT004/3 A'03) Determine the rotation and the deflection at  $C$  for the following beam. Take  $E = 200 \text{ kN/mm}^2$  and  $I = 8 \times 10^8 \text{ mm}^4$ . (Ans. 0.98 mm, 0.66 rads).

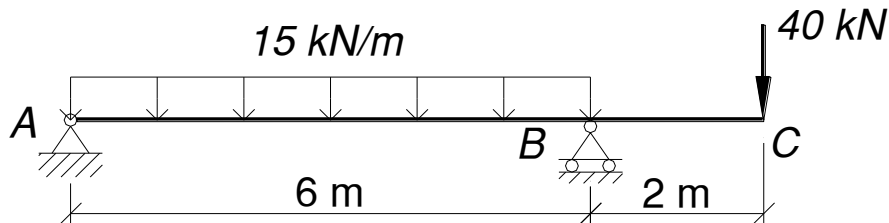

2. (DT004/3 S'04) Determine the rotation at A, the rotation at B, and the deflection at C, for the following beam. Take  $E = 200 \text{ kN/mm}^2$  and  $I = 8 \times 10^8 \text{ mm}^4$ . (Ans.  $\theta_A = 365/EI$ ;  $\theta_B = 361.67/EI$ ;  $\delta_C = 900/EI$ ).

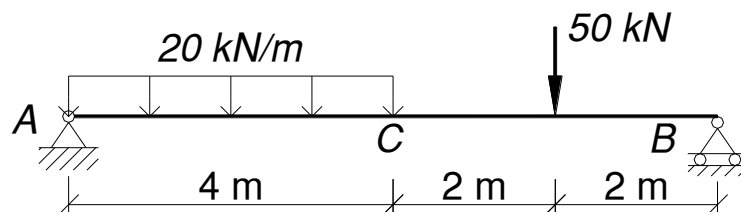

3. (DT004/3 A'04) Determine the deflection at C, for the following beam. Check your answer using  $\delta_C = 5wL^4/384EI + PL^3/48EI$ . Take  $E = 200 \text{ kN/mm}^2$  and  $I = 8 \times 10^8 \text{ mm}^4$ . The symbols  $w$ ,  $L$  and  $P$  have their usual meanings. (Ans. 2.67 mm).

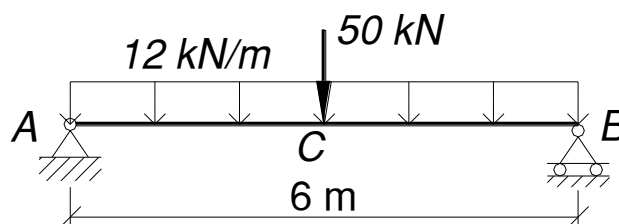

4. (DT004/3 S'05) Determine the deflection at  $B$  and  $D$  for the following beam. Take  $E = 200 \text{ kN/mm}^2$  and  $I = 8 \times 10^8 \text{ mm}^4$ . (Ans.  $1.48 \text{ mm} \uparrow$ ,  $7.55 \text{ mm} \downarrow$ ).

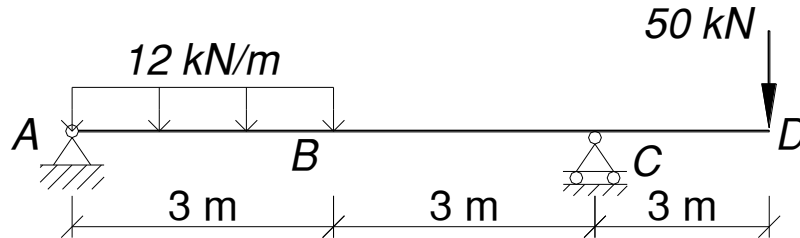

5. (DT004/3 A'05) Verify that the rotation at  $A$  is smaller than that at  $B$  for the following beam. Take  $E = 200 \text{ kN/mm}^2$  and  $I = 8 \times 10^8 \text{ mm}^4$ . (Ans.  $\theta_A = -186.67/EI$ ;  $\theta_B = -240/EI$ ;  $\delta_C = -533.35/EI$ ).

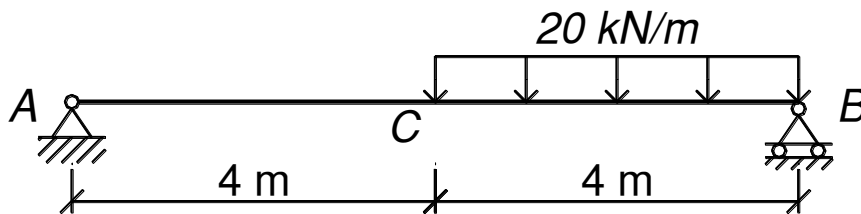

6. (DT004/3 S'06) Determine the location of the maximum deflection between  $A$  and  $B$ , accurate to the nearest 0.01 m and find the value of the maximum deflection between  $A$  and  $B$ , for the following beam. Take  $E = 200 \text{ kN/mm}^2$  and  $I = 8 \times 10^8 \text{ mm}^4$ . (Ans. 2.35 m; -0.5 mm)

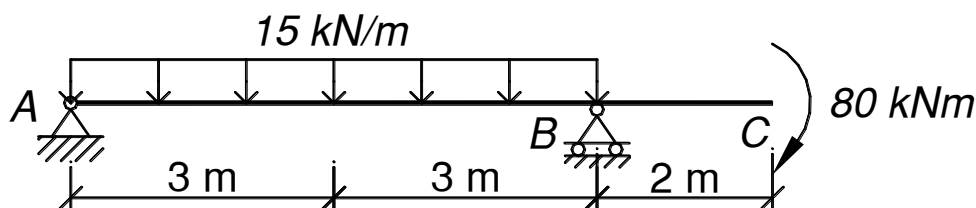

7. (DT004/3 A'06) Determine the location of the maximum deflection between  $A$  and  $B$ , accurate to the nearest 0.01 m and find the value of the maximum deflection between  $A$  and  $B$ , for the following beam. Take  $E = 200 \text{ kN/mm}^2$  and  $I = 8 \times 10^8 \text{ mm}^4$ . (Ans. 2.40 m;  $80/EI$ ).

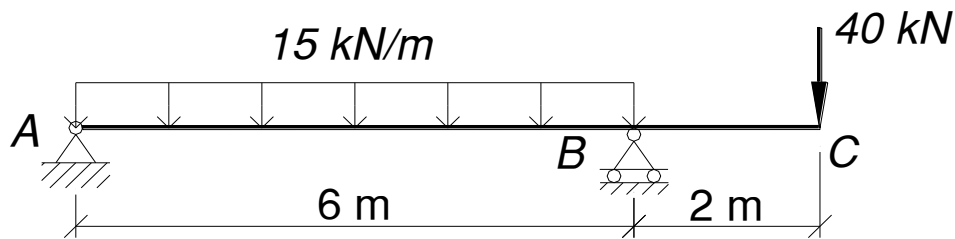

8. (DT004/3 S2R'07) Determine the rotation at  $A$ , the rotation at  $B$ , and the deflection at  $C$ , for the following beam. Check your answer using  $\delta_c = 5wL^4/384EI + PL^3/48EI$ . Take  $E = 200 \text{ kN/mm}^2$  and  $I = 8 \times 10^8 \text{ mm}^4$ . The symbols  $w$ ,  $L$  and  $P$  have their usual meanings. (Ans.  $-360/EI$ ,  $+360/EI$ ,  $-697.5/EI$ )

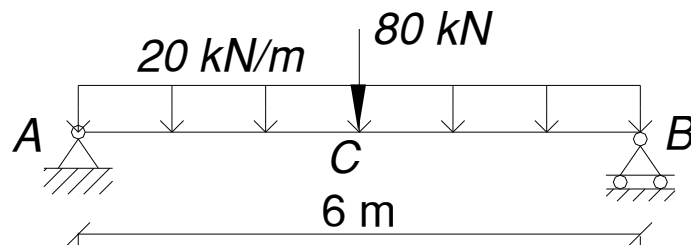

## 3. Indeterminate Beams

### 3.1 Basis

In solving statically determinate structures, we have seen that application of Macaulay's Method gives two unknowns:

1. Rotation constant of integration;
2. Deflection constant of integration.

These unknowns are found using the known geometrical constraints (or boundary conditions) of the member. For example, at a pin or roller support we know the deflection is zero, whilst at a fixed support we know that both deflection and rotation are zero. From what we have seen we can conclude that in any stable statically determinate structure there will always be enough geometrical constraints to find the two unknowns – if there isn't, the structure simply is not stable, and is a mechanism.

Considering indeterminate structures, we will again have the same two unknown constants of integration, in addition to the extra unknown support reactions. However, for each extra support introduced, we have an associated geometric constraint, or known displacement. Therefore, we will always have enough information to solve any structure. It simply falls to us to express our equations in terms of our unknowns (constants of integration and redundant reactions) and apply our known displacements to solve for these unknowns, thus solving the structure as a whole.

This is best explained by example, but keep in mind the general approach we are using.

### 3.2 Example 6 – Propped Cantilever with Overhang

#### Problem

Determine the maximum deflection for the following prismatic beam, and solve for the bending moment, shear force and deflected shape diagrams.

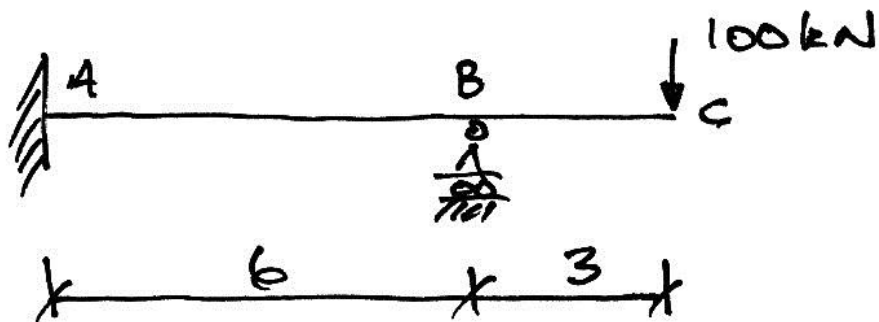

**Solution**

Before starting the problem, consider the qualitative behaviour of the structure so that we have an idea of the reactions' directions and the deflected shape:

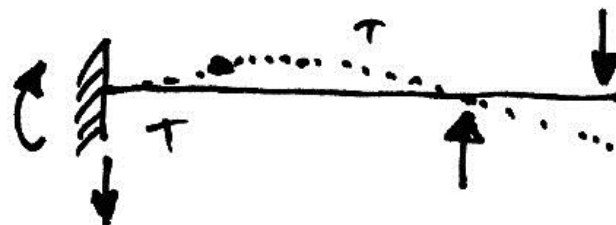

Since this is a 1° indeterminate structure we must choose a redundant and use the principle of superposition:

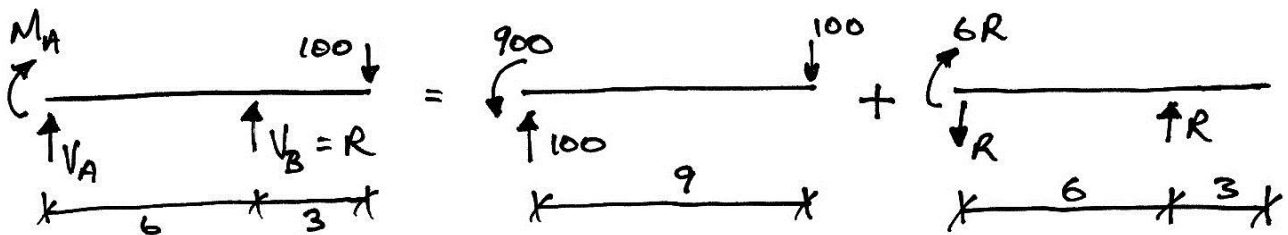

Next, we express all other reactions in terms of the redundant, and draw the free-body diagram for Macaulay's Method:

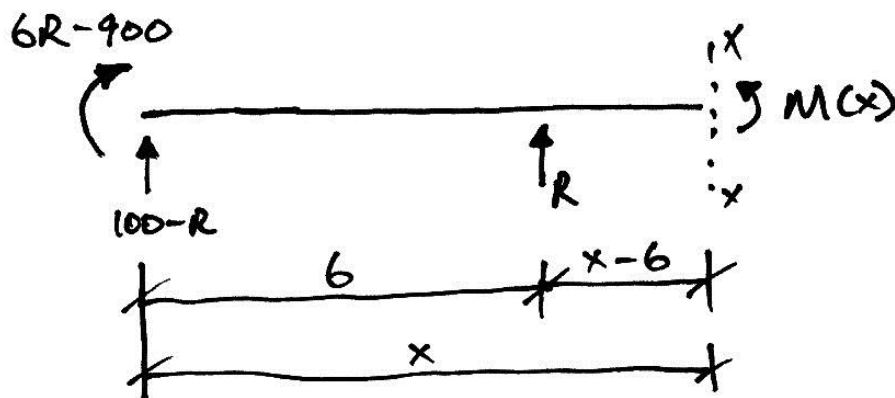

Proceeding as usual, we take moments about the cut, being careful to properly locate the moment reaction at  $A$  using the correct discontinuity function format:

$$M(x) - (6R - 900)[x]^0 - (100 - R)x - R[x - 6] = 0$$

Since  $x$  will always be positive we can remove the Macaulay brackets for the moment reaction at  $A$ , and we then have:

$$M(x) = EI \frac{d^2 y}{dx^2} = (6R - 900)x^0 + (100 - R)x + R[x - 6] \quad \text{Equation 1}$$

From which:

$$EI \frac{dy}{dx} = (6R - 900)x + \frac{(100 - R)}{2}x^2 + \frac{R}{2}[x - 6]^2 + C_\theta \quad \text{Equation 2}$$

And:

$$EIy = \frac{(6R - 900)}{2}x^2 + \frac{(100 - R)}{6}x^3 + \frac{R}{6}[x - 6]^3 + C_\theta x + C_\delta \quad \text{Equation 3}$$

Thus we have three unknowns to solve for, and we have three knowns we can use:

1. no deflection at  $A$  – fixed support;
2. no rotation at  $A$  – fixed support;
3. no deflection at  $B$  – roller support.

As can be seen the added redundant support both provides an extra unknown reaction, as well as an extra known geometric condition.

Applying the first boundary condition, we know that at  $x=0$ ,  $y=0$ :

$$EI(0) = \frac{(6R-900)}{2}(0)^2 + \frac{(100-R)}{6}(0)^3 + \frac{R}{6}[0-6]^3 + C_\theta(0) + C_\delta$$

$$C_\delta = 0$$

Applying the second boundary condition, at  $x=0$ ,  $\frac{dy}{dx} = 0$ :

$$EI(0) = (6R-900)(0) + \frac{(100-R)}{2}(0)^2 + \frac{R}{2}[0-6]^2 + C_\theta$$

$$C_\theta = 0$$

Applying the final boundary condition, at  $x=6$ ,  $y=0$ :

$$EI(0) = \frac{(6R-900)}{2}(6)^2 + \frac{(100-R)}{6}(6)^3 + \frac{R}{6}[6-6]^3$$

$$0 = (108R - 16200) + (3600 - 36R)$$

Thus we have an equation in  $R$  and we solve as:

$$0 = 72R - 12600$$

$$R = 175 \text{ kN } \uparrow$$

The positive answer means the direction we assumed initially was correct. We can now solve for the other reactions:

$$M_A = 6R - 900 = 6(175) - 900 = +150 \text{ kNm}$$

$$V_A = 100 - R = 100 - 175 = -75 \text{ kN i.e. } \downarrow$$



We now write **Equations 4 and 5**:

$$EI \frac{dy}{dx} = 150x + \frac{-75}{2}x^2 + \frac{175}{2}[x-6]^2$$

$$EIy = \frac{150}{2}x^2 + \frac{-75}{6}x^3 + \frac{175}{6}[x-6]^3$$

Finally to find the maximum deflection, we see from the qualitative behaviour of the structure that it will either be at the tip of the overhang, *C*, or between *A* and *B*. For the deflection at *C*, where  $x=9$ , we have, from Equation 5:

$$EI\delta_c = \frac{150}{2}(9)^2 + \frac{-75}{6}(9)^3 + \frac{175}{6}(3)^3$$

$$\delta_c = \frac{-2250}{EI}$$

This is downwards as expected. To find the local maximum deflection in Span *AB*, we solve for its location using Equation 4:

$$EI(0) = 150x + \frac{-75}{2}x^2 + \frac{175}{2}[x-6]^2 \text{ since } x \leq 6$$

$$0 = 150 - 37.5x$$

$$x = \frac{150}{37.5} = 4 \text{ m}$$

Therefore from Equation 5:

$$EI\delta_{\max}|_{AB} = \frac{150}{2}(4)^2 + \frac{-75}{6}(4)^3 + \frac{175}{6}[4-6]^3$$

$$\delta_{\max}|_{AB} = \frac{+400}{EI}$$

The positive result indicates an upward displacement, as expected. Therefore the maximum deflection is at C, and the overall solution is:

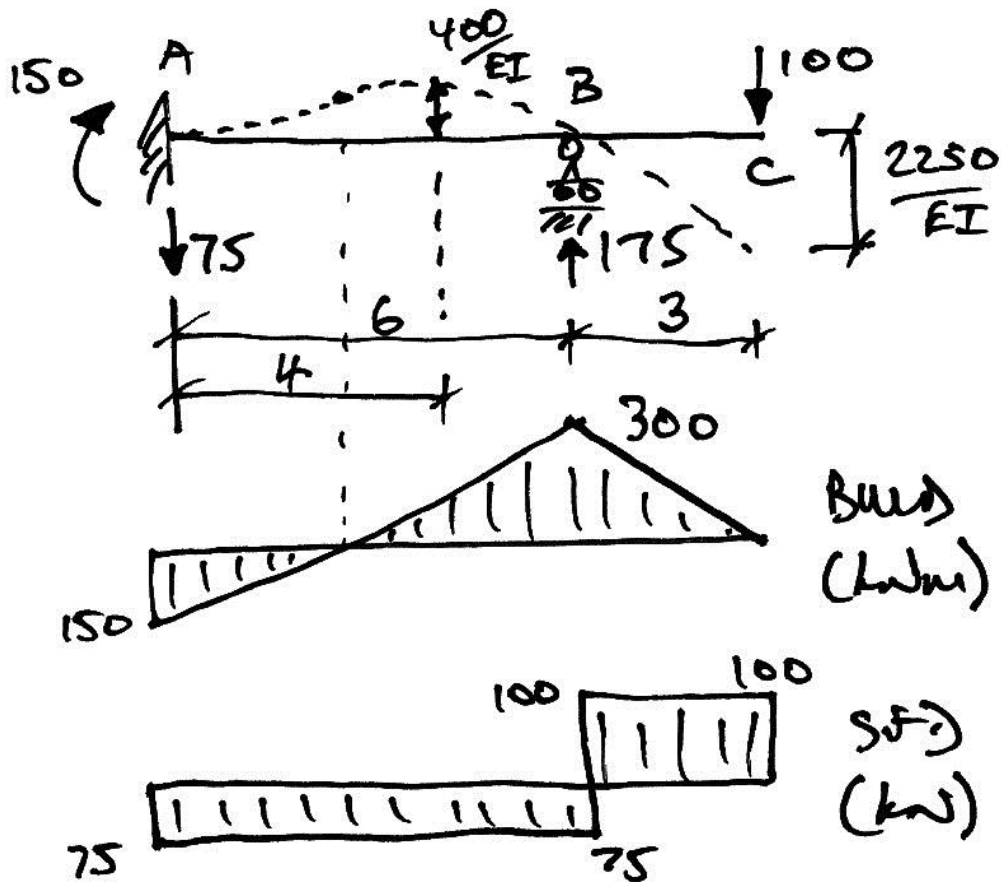

### 3.3 Example 7 – Indeterminate Beam with Hinge

#### Problem

For the following prismatic beam, find the rotations at the hinge, the deflection of the hinge, and the maximum deflection in member  $BE$ .

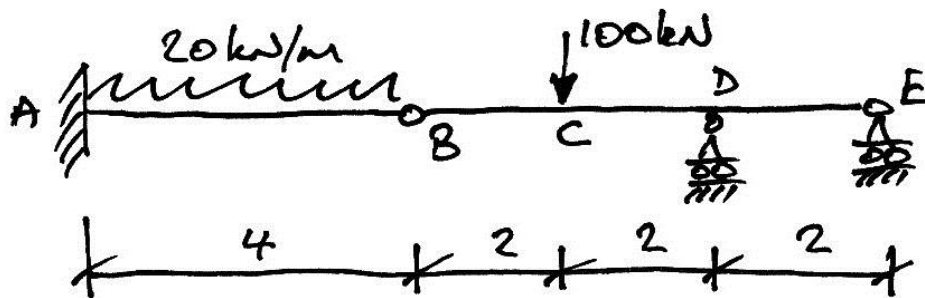

**Solution**

This is a 1 degree indeterminate beam. Once again we must choose a redundant and express all other reactions (and hence displacements) in terms of it. Considering first the expected behaviour of the beam:

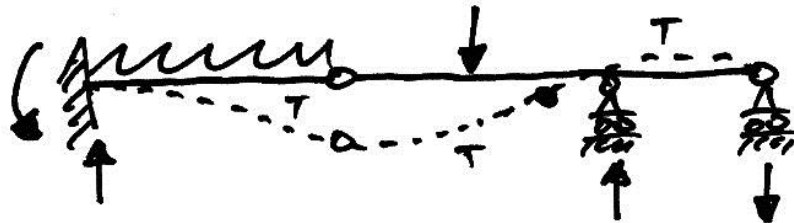

The shear in the hinge,  $V$ , is the ideal redundant, since it provides the obvious link between the two members:

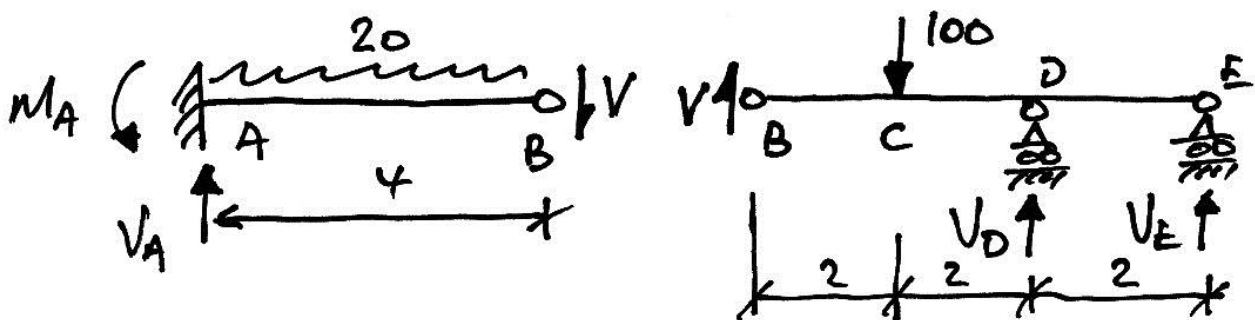

For member  $AB$ :

$$\sum M \text{ about } A = 0 \quad M_A - 20 \cdot \frac{4^2}{2} - 4V = 0 \quad \therefore M_A = 160 + 4V$$

$$\sum F_y = 0 \quad V_A - 20 \cdot 4 - V = 0 \quad \therefore V_A = 80 + V$$

And for member  $BE$ :

$$\begin{aligned} \sum M \text{ about } E = 0 & \quad 6V - 4 \cdot 100 + 2V_D = 0 & \quad \therefore V_D = 200 - 3V \\ \sum F_y = 0 & \quad V + V_D - V_E = 0 & \quad \therefore V_E = 100 - 2V \end{aligned}$$

Thus all reactions are known in terms of our chosen redundant. Next we calculate the deflection curves for each member, again in terms of the redundant.

**Member AB**

The relevant free-body diagram is:

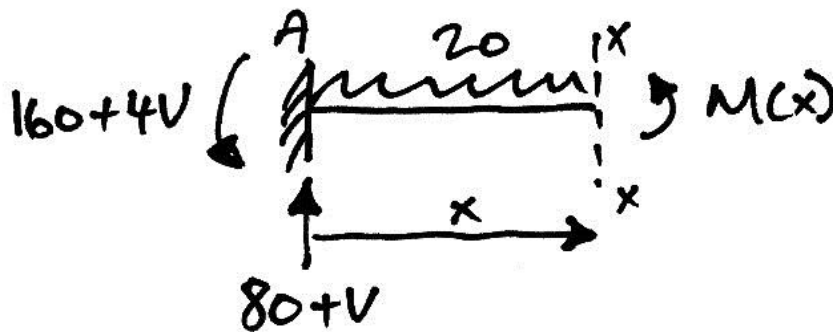

Taking moments about the cut gives:

$$M(x) + (160 + 4V)x^0 - (80 + V)x + \frac{20}{2}x^2 = 0$$

Thus, **Equation (AB)1** is:

$$M(x) = EI \frac{d^2y}{dx^2} = (80 + V)x - (160 + 4V)x^0 - \frac{20}{2}x^2$$

And **Equations (AB)2** and **3** are:

$$EI \frac{dy}{dx} = \frac{(80+V)}{2}x^2 - (160+4V)x^1 - \frac{20}{6}x^3 + C_\theta$$

$$EIy = \frac{(80+V)}{6}x^3 - \frac{(160+4V)}{2}x^2 - \frac{20}{24}x^4 + C_\theta x + C_\delta$$

Using the boundary conditions,  $x=0$ , we know that  $\frac{dy}{dx} = 0$ . Therefore we know  $C_\theta = 0$ . Also, since at  $x=0$ ,  $y=0$  we know  $C_\delta = 0$ . These may be verified by substitution into Equations 2 and 3. Hence we have:

$$EI \frac{dy}{dx} = \frac{(80+V)}{2}x^2 - (160+4V)x^1 - \frac{20}{6}x^3 \quad \text{Equation (AB)4}$$

$$EIy = \frac{(80+V)}{6}x^3 - \frac{(160+4V)}{2}x^2 - \frac{20}{24}x^4 \quad \text{Equation (AB)5}$$

**Member BE**

Drawing the free-body diagram, as shown, and taking moments about the cut gives:

$$M(x) + 100[x-2] - Vx - (200-3V)[x-4] = 0$$

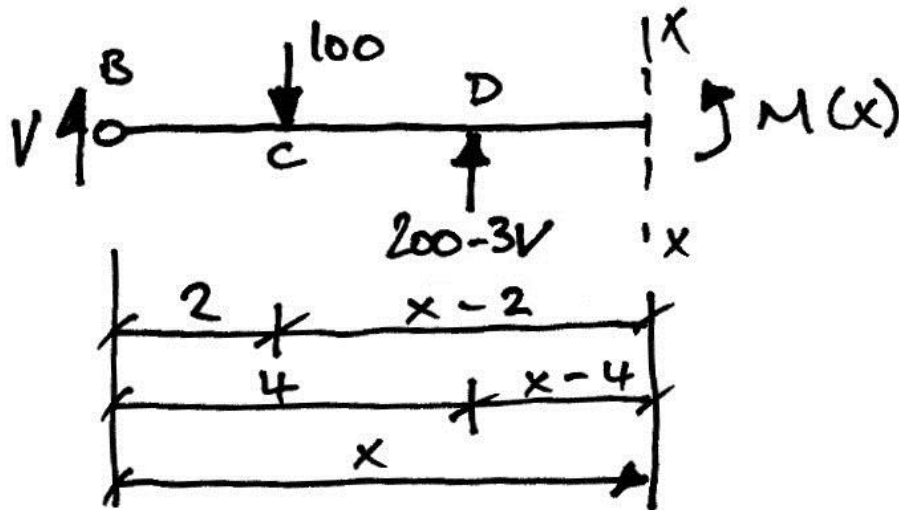

Thus Equation (BE)1 is:

$$M(x) = EI \frac{d^2 y}{dx^2} = Vx + (200 - 3V)[x - 4] - 100[x - 2]$$

Giving Equations (BE)2 and 3 as:

$$EI \frac{dy}{dx} = \frac{V}{2}x^2 + \frac{(200 - 3V)}{2}[x - 4]^2 - \frac{100}{2}[x - 2]^2 + C_\theta$$

$$EIy = \frac{V}{6}x^3 + \frac{(200 - 3V)}{6}[x - 4]^3 - \frac{100}{6}[x - 2]^3 + C_\theta x + C_\delta$$

The boundary conditions for this member give us  $y=0$  at  $x=4$ , for support D.

Hence:

$$EI(0) = \frac{V}{6}(4)^3 + \frac{(200 - 3V)}{6}[4 - 4]^3 - \frac{100}{6}(2)^3 + 4C_\theta + C_\delta$$

Which gives:

$$4C_{\theta} + C_{\delta} + \frac{32}{3}V - \frac{400}{3} = 0 \quad \text{(a)}$$

For support  $E$ , we have  $y = 0$  at  $x = 6$ , giving:

$$EI(0) = \frac{V}{6}(6)^3 + \frac{(200 - 3V)}{6}(2)^3 - \frac{100}{6}(4)^3 + 6C_{\theta} + C_{\delta}$$

Thus:

$$6C_{\theta} + C_{\delta} + 32V - 800 = 0 \quad \text{(b)}$$

Subtracting (a) from (b) gives:

$$2C_{\theta} + 0 + \frac{64}{3}V - \frac{2000}{3} = 0$$
$$C_{\theta} = -\frac{32}{3}V + \frac{1000}{3}$$

And thus from (b):

$$6\left(-\frac{32}{3}V + \frac{1000}{3}\right) + C_{\delta} + 32V - 800 = 0$$
$$C_{\delta} = 32V - 1200$$

Thus we write **Equations (BE)4** and **5** respectively as:



$$EI \frac{dy}{dx} = \frac{V}{2}x^2 + \frac{(200-3V)}{2}[x-4]^2 - \frac{100}{2}[x-2]^2 + \left(-\frac{32}{3}V + \frac{1000}{3}\right)$$

$$EIy = \frac{V}{6}x^3 + \frac{(200-3V)}{6}[x-4]^3 - \frac{100}{6}[x-2]^3 + \left(-\frac{32}{3}V + \frac{1000}{3}\right)x + (32V - 1200)$$

Thus both sets of equations for members  $AB$  and  $BE$  are ion terms of  $V$  – the shear force at the hinge. Now we enforce compatibility of displacement at the hinge, in order to solve for  $V$ .

For member  $AB$ , the deflection at  $B$  is got from Equation (AB)5 for  $x = 4$ :

$$\begin{aligned} EI\delta_{BA} &= \frac{(80+V)}{6}(4)^3 - \frac{(160+4V)}{2}(4)^2 - \frac{20}{24}(4)^4 \\ &= \frac{2560}{3} + \frac{32}{3}V - 1280 - 32V - \frac{640}{3} \\ &= -\frac{64}{3}V - 640 \end{aligned}$$

And for member  $BE$ , the deflection at  $B$  is got from Equation (BE)5 for  $x = 0$ :

$$\begin{aligned} EI\delta_{BE} &= \frac{V}{6}(0)^3 + \frac{(200-3V)}{6}[0-4]^3 - \frac{100}{6}[0-2]^3 + C_\theta(0) + C_\delta \\ &= C_\delta \\ &= 32V - 1200 \end{aligned}$$

Since  $\delta_{BA} \equiv \delta_{BE} \equiv \delta_B$ , we have:

$$-\frac{64}{3}V - 640 = 32V - 1200$$

$$-\frac{160}{3}V = -560$$

$$V = +10.5 \text{ kN}$$

The positive answer indicates we have chosen the correct direction for  $V$ . Thus we can work out the relevant quantities, recalling the previous free-body diagrams:

- $M_A = 160 + 4(10.5) = 202 \text{ kNm}$
- $V_A = 80 + 10.5 = 90.5 \text{ kN} \uparrow$
- $V_D = 200 - 3(10.5) = 168.5 \text{ kN} \uparrow$
- $V_E = 100 - 2(10.5) = 79 \text{ kN} \downarrow$

### Deformations at the Hinge

For member  $BE$  we now know:

$$C_\delta = 32(10.5) - 1200 = -864$$

And since this constant is the initial deflection of member  $BE$ :

$$EI\delta_B = -864$$

$$\delta_B = \frac{-864}{EI}$$

Which is a downwards deflection as expected. The rotation at the hinge for member  $AB$  is got from Equation (AB)4

$$EI\theta_{BA} = \frac{90.5}{2}(4)^2 - 202(4) - \frac{20}{6}(4)^3$$

$$\theta_{BA} = \frac{-297.3}{EI}$$

The sign indicates movement in the direction shown:

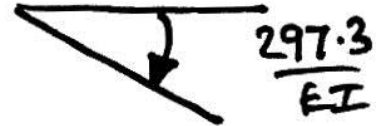

Also, for member *BE*, knowing *V* gives:

$$C_{\theta} = -\frac{32}{3}(10.5) + \frac{1000}{3} = +221.3$$

And so the rotation at the hinge for member *BE* is:

$$EI\theta_{BE} = \frac{10.5}{2}(0)^2 + \frac{168.5}{2}[0-4]^2 - \frac{100}{2}[0-2]^2 + 221.3$$

$$\theta_{BE} = \frac{+221.3}{EI}$$

The movement is therefore in the direction shown:



The deformation at the hinge is thus summarized as:

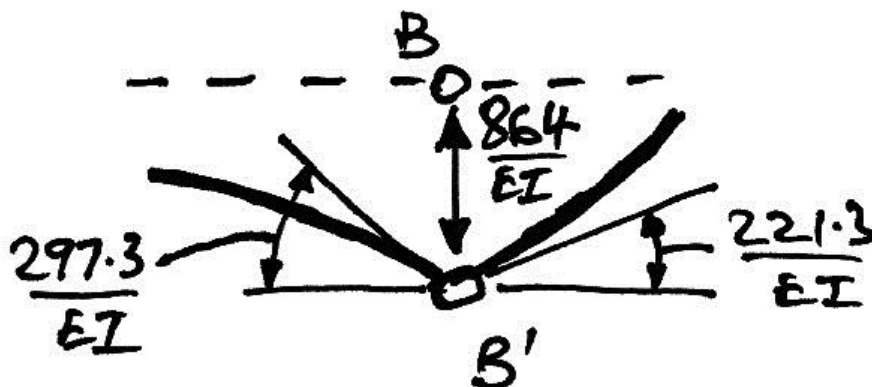

**Maximum Deflection in Member BE**

There are three possibilities:

- The deflection at *B*;
- A deflection in *B* to *D*;
- A deflection in *D* to *E*.

We check the rotation at *D* to see if there is a point of zero rotation between *B* and *D*. If there is then we have a local maximum deflection between *B* and *D*. If there isn't such a point, then there is no local maximum deflection. From Equation (BE)4:

$$EI\theta_D = \frac{10.5}{2}(4)^2 + \frac{168.5}{2}[4-4] - \frac{100}{2}(2)^2 + 221.3$$

$$\theta_D = \frac{+105.3}{EI}$$



Therefore since the deflection at both *B* and *D* are positive there is no point of zero rotation between *B* and *D*, and thus no local maximum deflection. Examining the deflected shape, we see that we must have a point of zero rotation between *D* and *E* since the rotation at *E* must be negative:

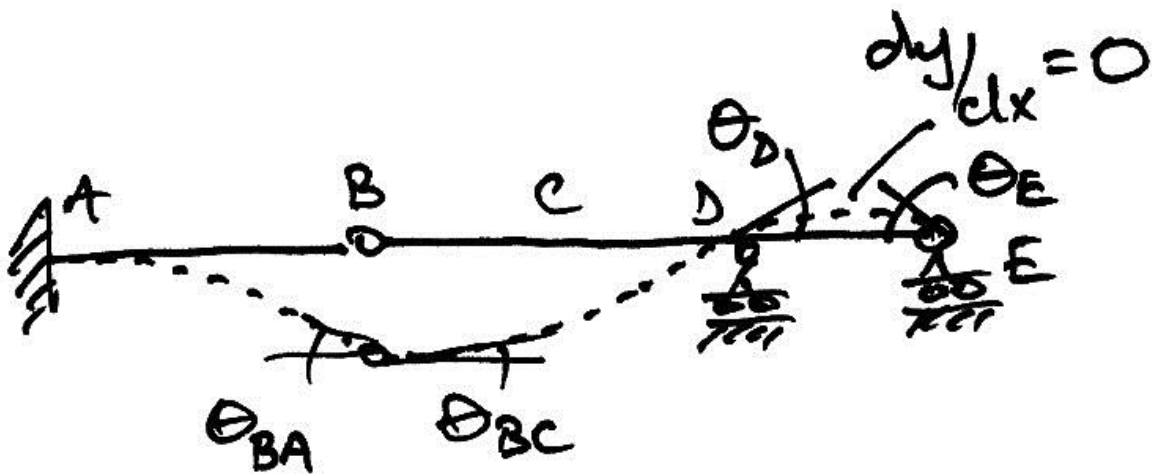

We are interested in the location  $x$  where we have zero rotation between  $D$  and  $E$ . Therefore we use Equation (BE)4, with the knowledge that  $4 \leq x \leq 6$ :

$$\begin{aligned}
 EI(0) &= \frac{10.5}{2}x^2 + \frac{168.5}{2}(x-4)^2 - \frac{100}{2}(x-2)^2 + 221.3 \\
 0 &= \frac{10.5}{2}x^2 + \frac{168.5}{2}(x^2 - 8x + 16) - \frac{100}{2}(x^2 - 4x + 4) + 221.3 \\
 0 &= \left(\frac{10.5}{2} + \frac{168.5}{2} - \frac{100}{2}\right)x^2 + \left(\frac{168.5}{2}(-8) + \frac{100}{2} \cdot 4\right)x \\
 &\quad + \left(\frac{168.5}{2}(16) - \frac{100}{2} \cdot 4 + 221.3\right) \\
 0 &= 39.5x^2 - 474x + 1369.3
 \end{aligned}$$

Thus we solve for  $x$  as:

$$\begin{aligned}
 x &= \frac{474 \pm \sqrt{474^2 - 4 \cdot 39.5 \cdot 1369.3}}{2 \cdot 39.5} \\
 &= 7.155 \text{ m or } 4.845 \text{ m}
 \end{aligned}$$

Since 7.155 m is outside the length of the beam, we know that the zero rotation, and hence maximum deflection occurs at  $x = 4.845$  m. Using Equation (BE)5:

$$\begin{aligned}
 EI\delta_{\max}|_{DE} &= \frac{10.5}{6}x^3 + \frac{168.5}{6}(0.845)^3 - \frac{100}{6}(2.845)^3 + 221.3(4.845) - 864 \\
 \delta_{\max}|_{DE} &= \frac{+40.5}{EI}
 \end{aligned}$$

Which is an upwards displacement, as expected, since it is positive. Since the deflection at  $B$  is greater in magnitude, the maximum deflection in member  $BE$  is the deflection at  $B$ ,  $864/EI$ .

The final solution for the problem is summarized as:

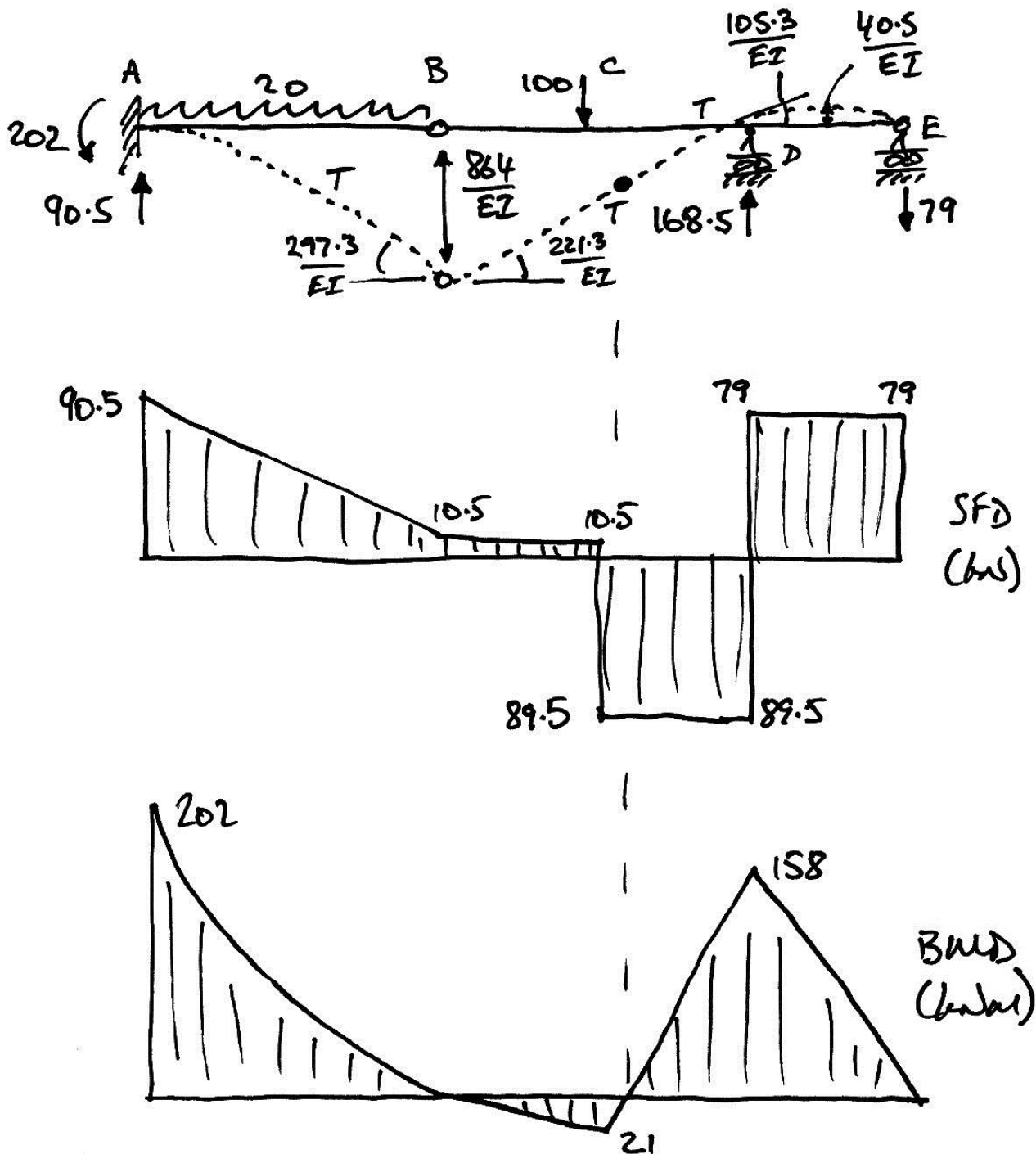

This solution has been put into Excel to give plots of the deflected shape, as follows:

**Macaulay's Method - Indeterminate Beam with Hinge**

X global	X for AB	X for BE	dy/dx AB	y AB	dy/dx BE	y BE
0.00	0.00	-4.00	0.0	0.0	305.3	-1861.3
0.25	0.25	-3.75	-47.7	-6.1	295.2	-1786.3
0.50	0.50	-3.50	-90.1	-23.4	285.6	-1713.7
0.75	0.75	-3.25	-127.5	-50.7	276.8	-1643.4
1.00	1.00	-3.00	-160.1	-86.8	268.6	-1575.2
1.25	1.25	-2.75	-188.3	-130.4	261.0	-1509.1
1.50	1.50	-2.50	-212.4	-180.6	254.1	-1444.7
1.75	1.75	-2.25	-232.8	-236.3	247.9	-1381.9
2.00	2.00	-2.00	-249.7	-296.7	242.3	-1320.7
2.25	2.25	-1.75	-263.4	-360.9	237.4	-1260.7
2.50	2.50	-1.50	-274.3	-428.1	233.1	-1201.9
2.75	2.75	-1.25	-282.6	-497.8	229.5	-1144.1
3.00	3.00	-1.00	-288.8	-569.3	226.6	-1087.1
3.25	3.25	-0.75	-293.0	-642.0	224.3	-1030.7
3.50	3.50	-0.50	-295.6	-715.6	222.6	-974.9
3.75	3.75	-0.25	-297.0	-789.7	221.7	-919.4
4.00	4.00	0.00	-297.3	-864.0	221.3	-864.0
4.25		0.25	0.0	0.0	221.7	-808.6
4.50		0.50	0.0	0.0	222.6	-753.1
4.75		0.75	0.0	0.0	224.3	-697.3
5.00		1.00	0.0	0.0	226.6	-640.9
5.25		1.25	0.0	0.0	229.5	-583.9
5.50		1.50	0.0	0.0	233.1	-526.1
5.75		1.75	0.0	0.0	237.4	-467.3
6.00		2.00	0.0	0.0	242.3	-407.3
6.25		2.25	0.0	0.0	244.8	-346.3
6.50		2.50	0.0	0.0	241.6	-285.4
6.75		2.75	0.0	0.0	232.9	-226.0
7.00		3.00	0.0	0.0	218.6	-169.4
7.25		3.25	0.0	0.0	198.7	-117.2
7.50		3.50	0.0	0.0	173.1	-70.6
7.75		3.75	0.0	0.0	142.0	-31.1
8.00		4.00	0.0	0.0	105.3	0.0
8.25		4.25	0.0	0.0	68.3	21.6
8.50		4.50	0.0	0.0	36.2	34.5
8.75		4.75	0.0	0.0	9.0	40.1
9.00		5.00	0.0	0.0	-13.2	39.5
9.25		5.25	0.0	0.0	-30.5	33.9
9.50		5.50	0.0	0.0	-42.8	24.7
9.75		5.75	0.0	0.0	-50.2	12.9
10.00		6.00	0.0	0.0	-52.7	0.0

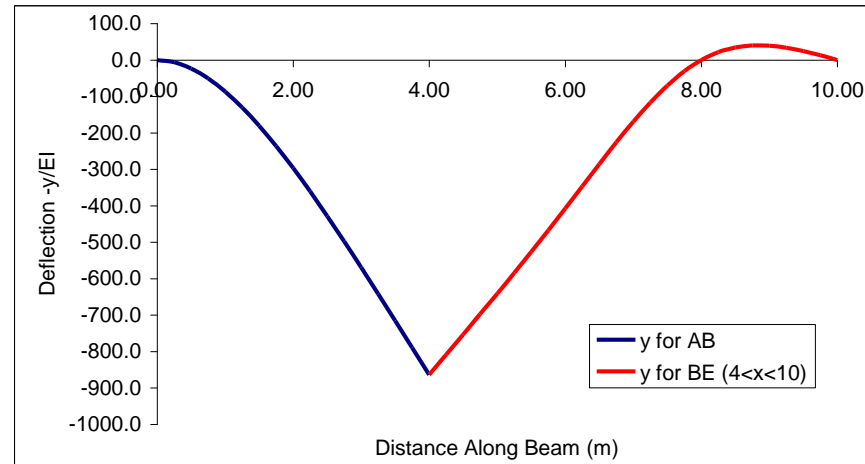
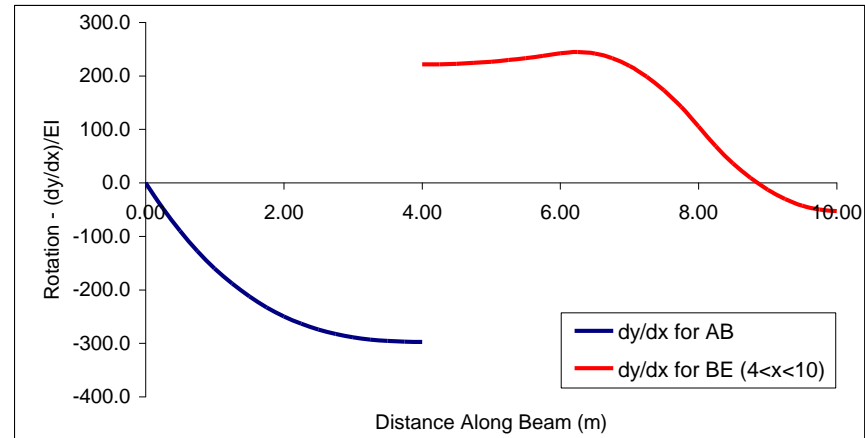

**Equation used in the Cells**

$$dy/dx \text{ AB} = (80+V)*x^2/2 - (160+4*V)*x - 20*x^3/6$$

$$y \text{ AB} = (80+V)*x^3/6 - (160+4*V)*x^2/2 - 20*x^4/24$$

$$dy/dx \text{ BE} = V*x^2/2 + (200-3*V)*MAX(x-4,0)^2/2 - 100*MAX(x-2,0)^2/2 + const1$$

$$y \text{ BE} = V*x^3/6 + (200-3*V)*MAX(x-4,0)^3/6 - 100*MAX(x-2,0)^3/6 + const1*x + const2$$

### 3.4 Problems

- For the beam shown, find the reactions and draw the bending moment, shear force, and deflected shape diagrams. Determine the maximum deflection and rotation at  $B$  in terms of  $EI$ .

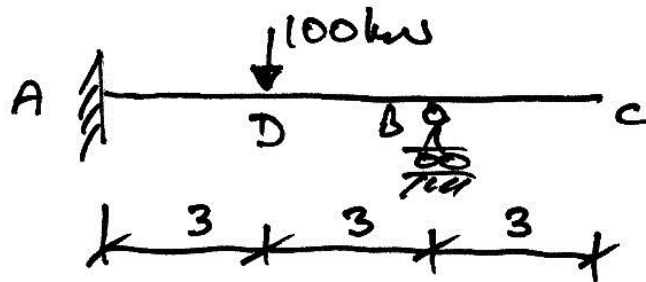

- For the beam shown, find the reactions and draw the bending moment, shear force, and deflected shape diagrams. Determine the maximum deflection and rotation at  $B$  in terms of  $EI$ .

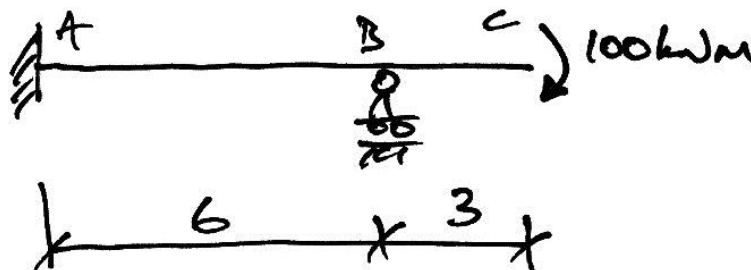

- For the beam shown, find the reactions and draw the bending moment, shear force, and deflected shape diagrams. Determine the maximum deflection and rotation at  $B$  in terms of  $EI$ .



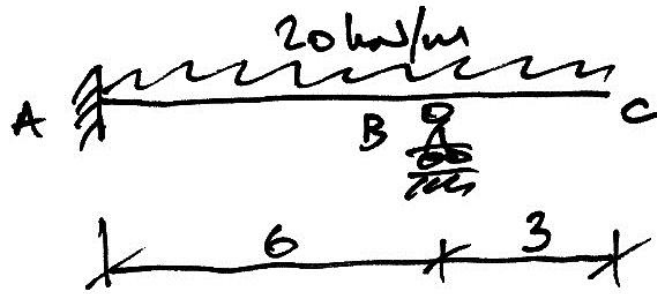

4. For the beam shown, find the reactions and draw the bending moment, shear force, and deflected shape diagrams. Determine the maximum deflection and the rotations at A, B, and C in terms of  $EI$ .

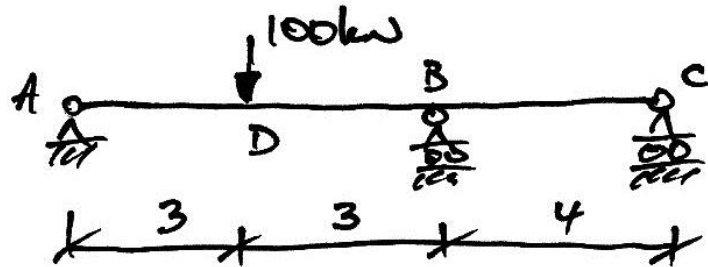

5. For the beam shown, find the reactions and draw the bending moment, shear force, and deflected shape diagrams. Determine the maximum deflection and the rotations at A, B, and C in terms of  $EI$ .

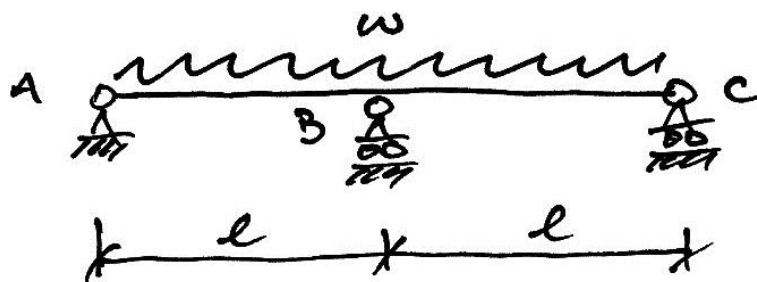

## 4. Indeterminate Frames

### 4.1 Introduction

Macaulay's method is readily applicable to frames, just as it is to beams. Both statically indeterminate and determinate frames can be solved. The method is applied as usual, but there is one extra factor:

*Compatibility of displacement must be maintained at joints.*

This means that:

- At rigid joints, this means that the rotations of members meeting at the joint must be the same.
- At hinge joints we can have different rotations for each member, but the members must remain connected.
- We must (obviously) still impose the boundary conditions that the supports offer the frame.

In practice, Macaulay's Method is only applied to basic frames because the number of equations gets large otherwise. For more complex frames other forms of analysis can be used (such as moment distribution, virtual work, Mohr's theorems, etc.) to determine the bending moments. Once these are known, the deflections along individual members can then be found using Macaulay's method applied to the member itself.

### 4.2 Example 8 – Simple Frame

#### Problem

For the following prismatic frame, find the horizontal deflection at  $C$  and draw the bending moment diagram:

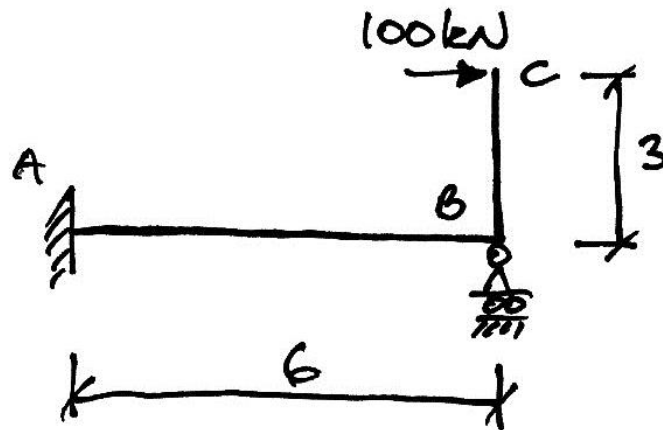

**Solution**

Before starting, assess the behaviour of the frame:

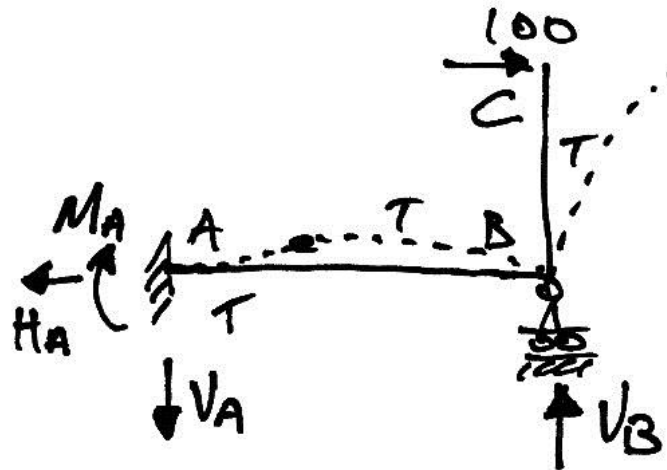

The structure is 1 degree indeterminate. Therefore we need to choose a redundant. Choosing  $V_B$ , we can now calculate the reactions in terms of the redundant by taking moments about A:

$$M_A + 100 \cdot 3 - 6R = 0$$

$$M_A = 6R - 300$$

Thus the reactions are:

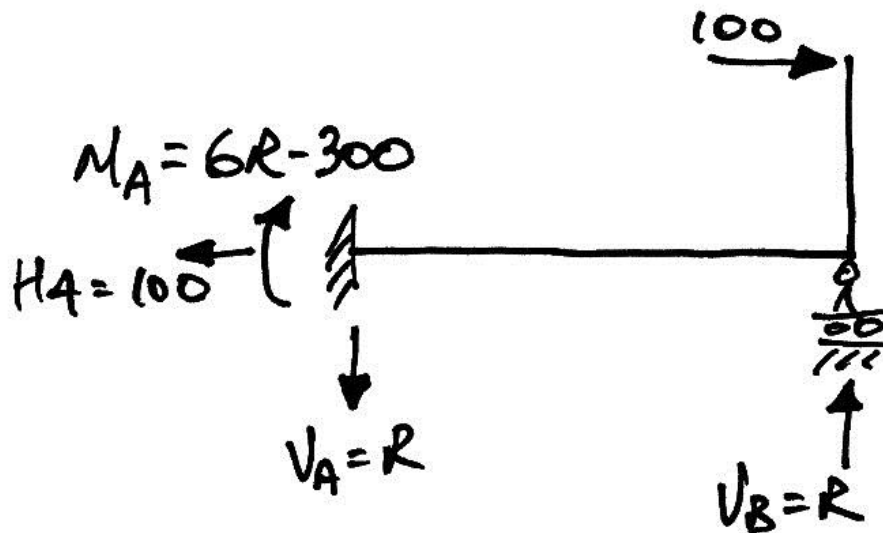

And we can now draw a free-body diagram for member AB, in order to apply Macaulay's Method to AB:

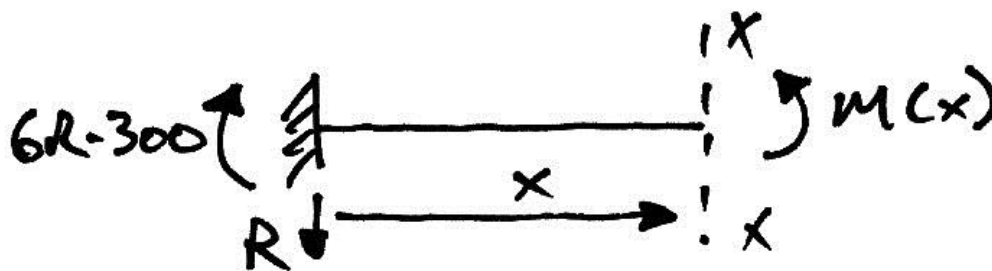

Taking moments about the cut, we have:

$$M(x) - (6R - 300)[x]^0 + Rx = 0$$

Thus:

$$M(x) = EI \frac{d^2 y}{dx^2} = (6R - 300)[x]^0 - Rx \quad \text{Equation 1}$$

Giving:

$$EI \frac{dy}{dx} = (6R - 300)[x]^1 - \frac{R}{2}x^2 + C_\theta \quad \text{Equation 2}$$

$$EIy = \frac{(6R - 300)}{2}[x]^2 - \frac{R}{6}x^3 + C_\theta x + C_\delta \quad \text{Equation 3}$$

Applying  $y = 0$  and  $\frac{dy}{dx} = 0$  at  $x = 0$  gives us  $C_\theta = 0$  and  $C_\delta = 0$ . Therefore:

$$EI \frac{dy}{dx} = (6R - 300)[x]^1 - \frac{R}{2}x^2 \quad \text{Equation 4}$$

$$EIy = \frac{(6R - 300)}{2}[x]^2 - \frac{R}{6}x^3 \quad \text{Equation 5}$$

Further, we know that at  $x = 6$ ,  $y = 0$  because of support  $B$ . Therefore:

$$EI(0) = \frac{(6R - 300)}{2}(6)^2 - \frac{R}{6}(6)^3$$

$$0 = 3R - 150 - R$$

$$R = +75 \text{ kN i.e. } \uparrow$$

Thus we now have:

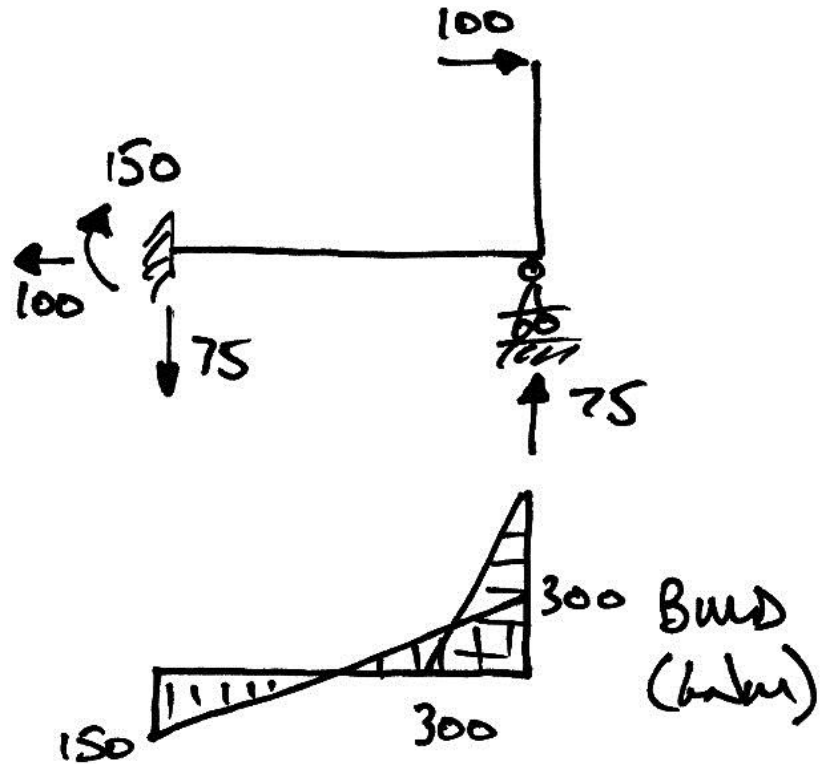

And the deflected shape is:

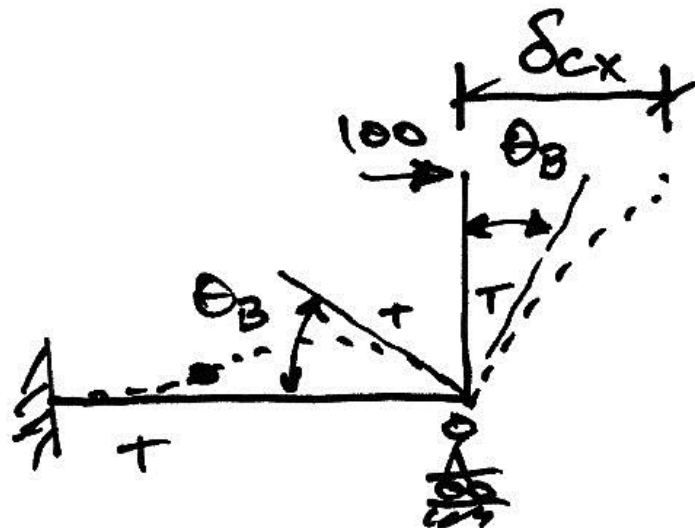

In order to calculate  $\delta_{Cx}$ , we need to look at the deflections at C more closely:

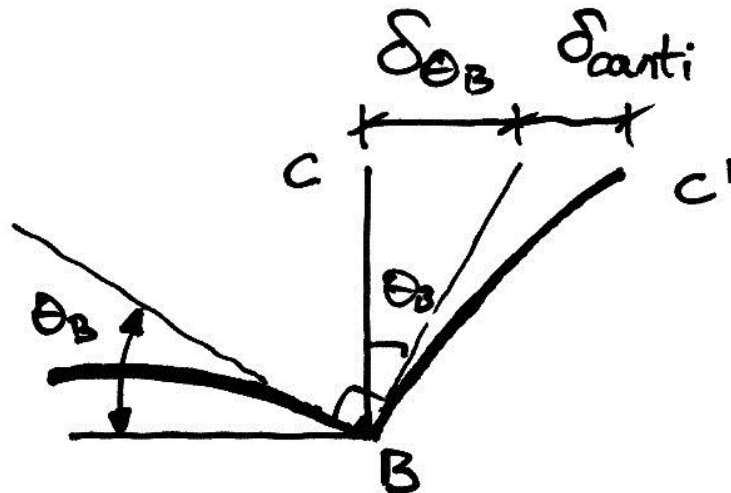

From this diagram, it is apparent that the deflection at  $C$  is made up of:

- A deflection due to the rotation of joint  $B$ , denoted  $\delta_{\theta_B}$  ;
- A deflection caused by bending of the cantilever member  $BC$ ,  $\delta_{canti}$  .

From  $S = R\theta$  , we know that:

$$\delta_{\theta_B} = 3\theta_B$$

So to find  $\theta_B$  we use Equation 4 with  $x = 6$ :

$$EI\theta_B = 150(6) - \frac{75}{2}(6)^2$$

$$\theta_B = \frac{-450}{EI}$$

The sense of the rotation is thus as shown:

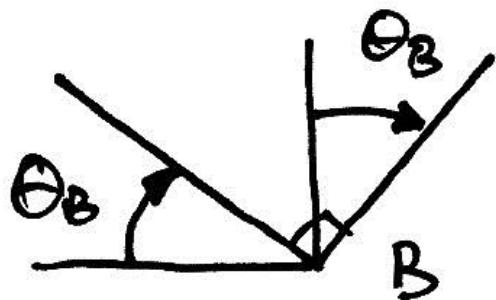



The deflection at  $C$  due to the rotation of joint  $B$  is:

$$\begin{aligned}\delta_{\theta_B} &= 3 \left( \frac{450}{EI} \right) \\ &= \frac{1350}{EI}\end{aligned}$$

Note that we don't need to worry about the sign of the rotation, since we know that  $C$  is moving to the right, and that the rotation at  $B$  is aiding this movement.

The cantilever deflection of member  $BC$  can be got from standard tables as:

$$\delta_{\text{canti}} = \frac{PL^3}{3EI} = \frac{100 \cdot 3^3}{3EI} = \frac{900}{EI}$$

We can also get this using Macaulay's Method applied to member  $BC$ :

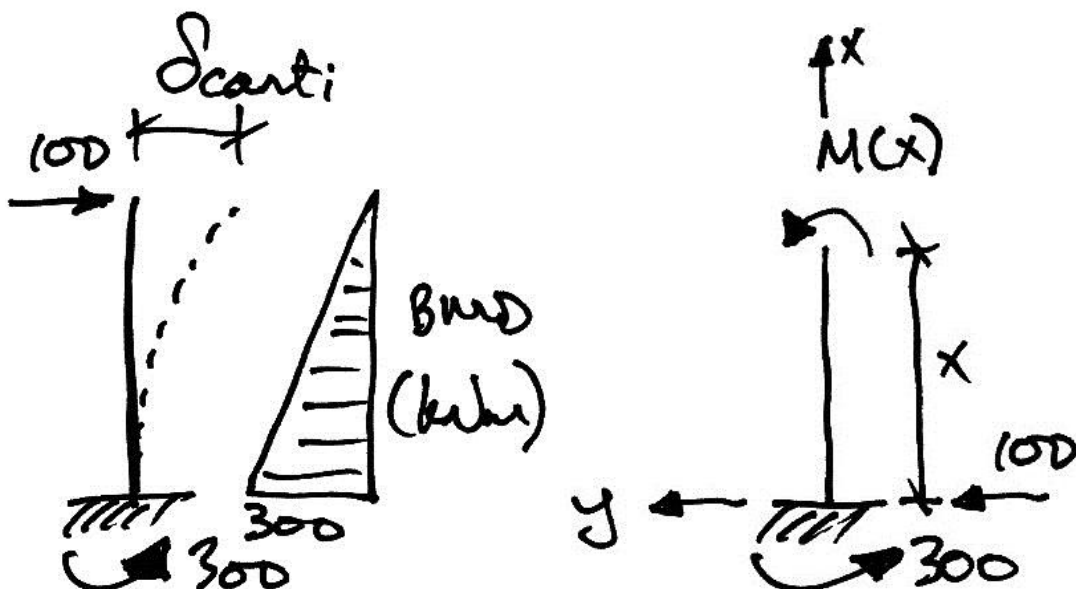

Note the following:

- Applying Macaulay's method to member  $BC$  will not give the deflection at  $C$  – it will only give the deflection at  $C$  due to bending of member  $BC$ . Account must be made of the rotation of joint  $B$ .
- The axis system for Macaulay's method is as previously used, only turned through 90 degrees. Thus negative deflections are to the right, as shown.

Taking moments about the cut:

$$M(x) + 300[x]^0 - 100x = 0$$

$$M(x) = EI \frac{d^2 y}{dx^2} = 100x - 300[x]^0$$

$$EI \frac{dy}{dx} = \frac{100}{2} x^2 - 300[x]^1 + C_\theta$$

$$EIy = \frac{100}{6} x^3 - \frac{300}{2} [x]^2 + C_\theta x + C_\delta$$

But we know that  $y = 0$  and  $\frac{dy}{dx} = 0$  at  $x = 0$  so  $C_\theta = 0$  and  $C_\delta = 0$ . Therefore:

$$EIy = \frac{100}{6} x^3 - \frac{300}{2} [x]^2$$

And for the cantilever deflection at  $C$ :

$$EI\delta_{\text{canti}} = \frac{100}{6}(3)^3 - \frac{300}{2}(3)^2$$
$$\delta_{\text{canti}} = \frac{-900}{EI}$$

This is the same as the standard table result, as expected. Further, since a negative answer here means a deflection to the right, the total deflection to the right at  $C$  is:

$$\begin{aligned}\delta_{Cx} &= \delta_{\theta B} + \delta_{\text{canti}} \\ &= \frac{1350}{EI} + \frac{900}{EI} \\ &= \frac{2250}{EI}\end{aligned}$$

### 4.3 Problems

1. For the prismatic frame shown, find the reactions and draw the bending moment, shear force, and deflected shape diagrams. Verify the following displacements:  $\theta_B = 80/EI$ ;  $\delta_{Dy} = 766.67/EI \downarrow$ ;  $\delta_{Bx} = 200/EI$  (direction not given because to do so would influence answer).

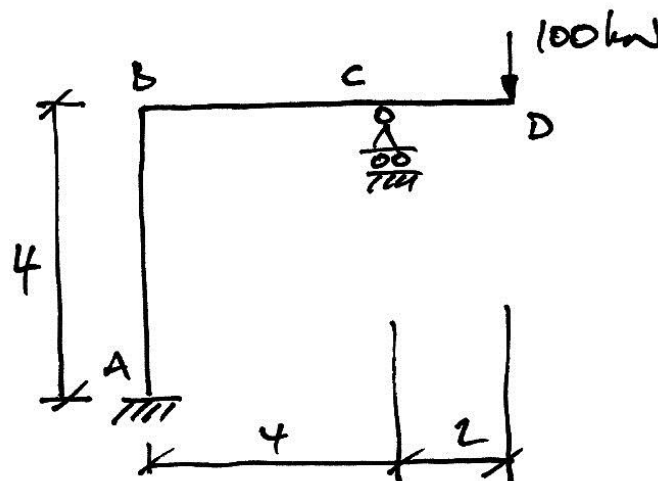

2. For the prismatic frame shown, find the reactions and draw the bending moment, shear force, and deflected shape diagrams. Verify the following displacements:  $\theta_C = 200/EI$ ;  $\delta_{By} = 666.67/EI \downarrow$ ;  $\delta_{Dx} = 400/EI$  (again direction not given because to do so would influence answer).

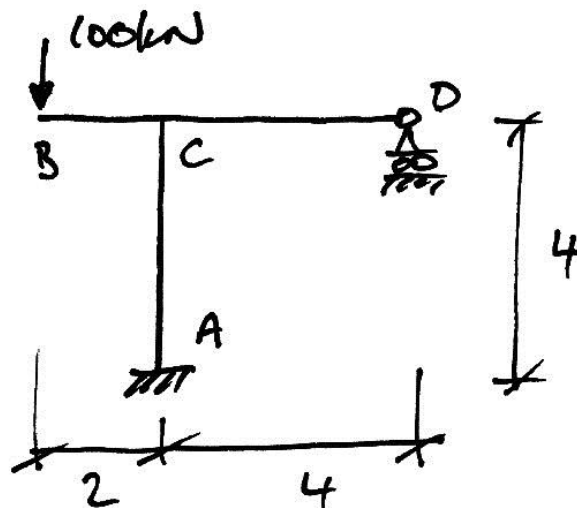

## 5. Past Exam Questions

### 5.1 Summer 2003

- (b) (i) Classify the structure shown in Fig. Q2(b), indicating whether the structure is unstable, stable and statically determinate, or stable and statically indeterminate, (giving the degree of indeterminacy). (2 marks)
- (ii) Using Macaulay's Method, determine the deflection at C. Assume  $E = 200 \text{ kN/mm}^2$  and  $I = 15 \times 10^7 \text{ mm}^4$ . (18 marks)

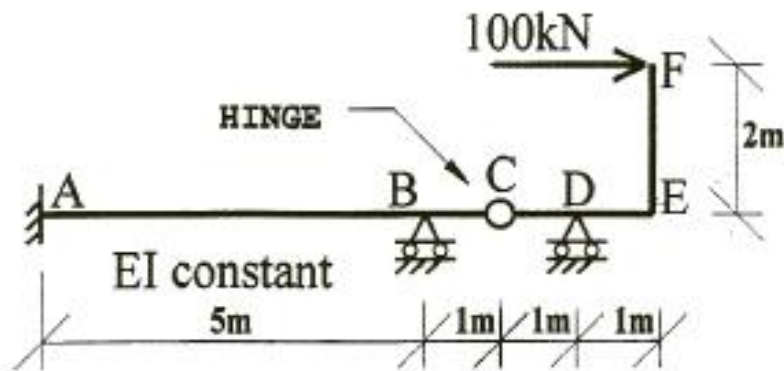

FIG. Q2(b)

(Ans. 10.56 mm upwards)

5.2 Summer 2004

30/3/62

(4)

4. (a) Use the Moment-area Method (Mohr's Theorems) to determine, for the beam shown in Fig. Q4, the bending moment at all salient points. (12 marks)

Hence sketch the bending moment diagram. (3 marks)

- (b) Using Macaulay's Method, and the information determined in (a) above, calculate the maximum deflection in span AB and the deflection at C. (10 marks)

Assume  $EI = 200 \times 10^3 \text{ kNm}^2$ .

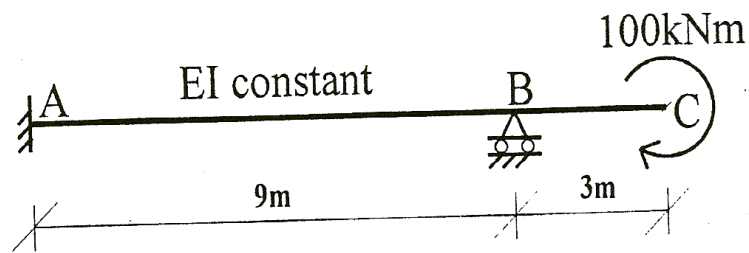

FIG. Q4

(Ans. 1.5 mm up; 5.63 mm down.)

**Note:** In the present course, the part (a) of this problem would also be solved using Macaulay's Method.

**5.3 Summer 2007**

4. (a)

**Part (a) not relevant**

(b) For the beam shown in Fig. Q4(b), using *Macaulay's Method*:

- (i) Determine the vertical reaction at joint *B*;
- (ii) Show that the moment reaction at joint *A* is  $wL^2/8$ .

(10 marks)

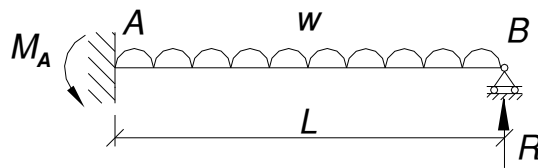

**FIG. Q4(b)**

(Ans.  $R = 3wL/8$ )

5.4 Autumn 2007

4. (a)

**Part (a) not relevant**

(b) For the beam shown in Fig. Q4, using *Macaulay's Method* and the results from part (a):

- (i) Determine the deflection at C;
- (ii) Determine the maximum deflection in span AB.

(10 marks)

**Note:**

Take  $EI = 200 \times 10^3 \text{ kNm}^2$  for all members.

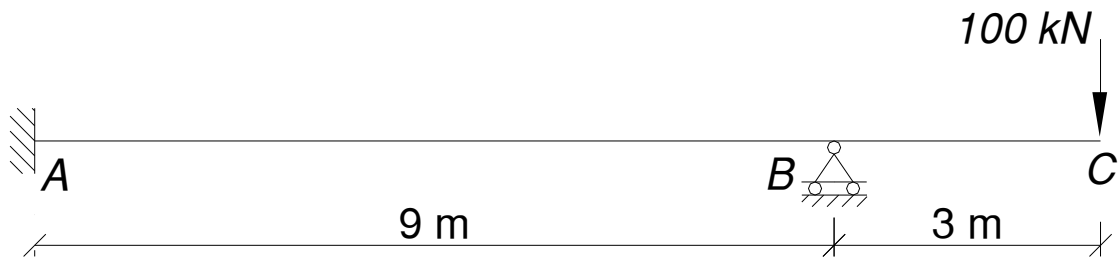

**FIG. Q4**

(Ans. 14.6 mm ↓, 4.5 mm ↑)



**5.5 Semester 2, 2007/8**

4. (a)

**Part (a) not relevant**

(b) For the prismatic beam of Fig. Q3(b), using *Macaulay's Method*, find the vertical deflection at *C* in terms of *EI*.

(10 marks)

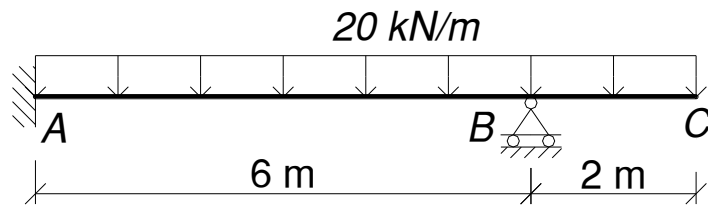

**FIG. Q3(b)**

(Ans.  $20/EI$ )

**5.6 Semester 2, 2008/9**

**QUESTION 1**

Using *Macaulay's Method*, for the beam shown in Fig. Q1:

- (i) Determine the reactions;
- (ii) Draw the bending moment diagram;
- (iii) Draw the deflected shape of the structure;
- (iv) Determine the deflection of joint *D*.

(25 marks)

**Note:**

- Take  $E = 200 \text{ kN/mm}^2$  and  $I = 15 \times 10^7 \text{ mm}^4$  for all members.

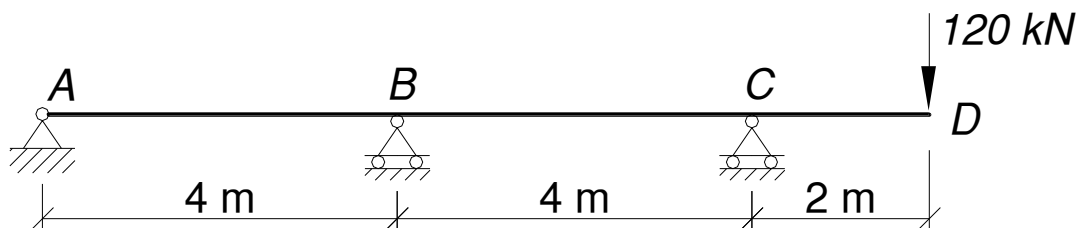

**FIG. Q1**

(Ans.  $V_B = 90 \text{ kN} \downarrow$ ,  $\delta_D = 44 \text{ mm} \downarrow$ )

**5.7 Semester 2, 2009/10**

**QUESTION 1**

Using *Macaulay's Method*, for the beam shown in Fig. Q1:

- (i) Determine the reactions;
- (ii) Draw the bending moment diagram;
- (iii) Draw the deflected shape of the structure;
- (iv) Determine the deflection at C;
- (v) Determine the maximum deflection in span AB.

(25 marks)

**Note:**

- Take  $E = 200 \text{ kN/mm}^2$  and  $I = 10 \times 10^7 \text{ mm}^4$  for all members.

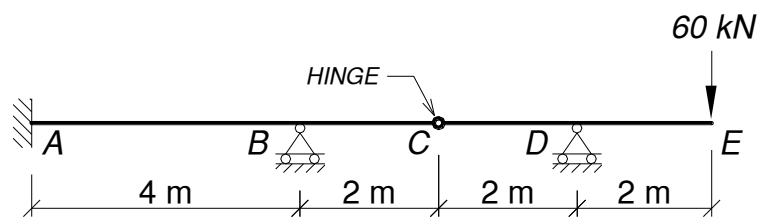

**FIG. Q1**

(Ans.  $V_B = 105 \text{ kN} \downarrow$ ,  $\delta_C = 3.55 \text{ mm} \downarrow$ )

## 6. Appendix

### 6.1 References

The basic reference is the two-page paper which started it all:

- Macaulay, W. H. (1919), 'Note on the deflection of the beams', *Messenger of Mathematics*, 48, pp. 129-130.

Most textbooks cover the application of the method, for example:

- Gere, J.M and Goodno, B.J. (2008), *Mechanics of Materials*, 7th Edn., Cengage Engineering.
- McKenzie, W.M.C. (2006), *Examples in Structural Analysis*, Taylor and Francis, Abington.
- Benham, P.P., Crawford, R.J. and Armstrong, C.G. (1996), *Mechanics of Engineering Materials*, 2nd Edn., Pearson Education.

Some interesting developments and uses of the step-functions method are:

- Biondi, B. and Caddemi, S. (2007), 'Euler–Bernoulli beams with multiple singularities in the flexural stiffness', *European Journal of Mechanics A/Solids*, 26 pp. 789–809.
- Falsone, G. (2002), 'The use of generalised functions in the discontinuous beam bending differential equations', *International Journal of Engineering Education*, Vol. 18, No. 3, pp. 337-343.

See [www.colincaprani.com](http://www.colincaprani.com) for notes on the use of Macaulay's Method in the development of a general beam analysis program, based upon the following work:

- Wilson, H.B., Turcotte, L.H., and Halpern, D. (2003), *Advanced Mathematics and Mechanics Applications Using MATLAB*, 3rd Edn., Chapman and Hall/CRC, Boca Raton, Florida.