



Magnitude[®] magnetic bearing centrifugal chillers



100-1500 tons

Manufactured in an ISO 9001 & ISO 14001 certified facility



People and ideas you can trust.™

Daikin Magnitude chillers, peak efficiency year after year



To instill productivity and promote efficiency, commercial buildings today must feel as comfortable as they look. That's where Magnitude counts most. Magnitude magnetic bearing water cooled chillers are designed to create the ultimate in climate-controlled environments for offices, K-12 schools, colleges, hospitals and healthcare facilities for the people who work, study, teach, heal and recover within their walls. Building owners and property managers realize the benefits, too, in terms of reliability and performance. And when it comes to saving energy, Magnitude is up to 40% more efficient than standard centrifugal chillers and offers substantially improved savings over the life of the unit.

Quiet operation



The Magnitude chiller is quiet with sound pressure ratings as low as 76 dBA, tested according to AHRI Standard 575. Sound levels will be even lower at reduced loads and non-standard design conditions.

This quiet operation makes Magnitude ideal for sound sensitive environments such as schools, performance halls, museums, and condominiums.

Magnetic bearing compressors

As reliable as they are efficient

- Magnetic bearings eliminate mechanical seals and wear surfaces for longer machine life.
- The simplicity of a direct-drive motor and shaft eliminates gears, slide valves and extra parts to increase reliability.
- VFD designed as an integrated component with the compressor and optimized by digital controls to reduce power consumption while maximizing chiller performance.
- Reduced in-rush current by utilizing a VFD; a gradual soft start that lessens mechanical and thermal stresses leading to increased motor life.
- Onboard digital controls to continuously monitor operating status and provide fault protections.
- Oil-free design eliminates oil management systems for improved compressor and system reliability. The oil-free design also eliminates the possibility of efficiency-robbing oil contamination of heat-transfer surfaces.

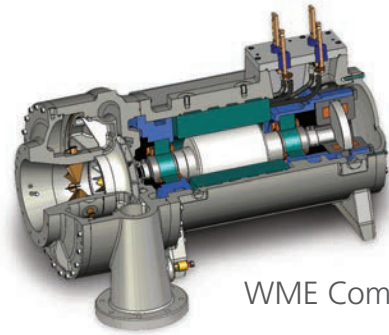

WME Compressor

Why magnetic bearing compressors are the right technology for today

The frictionless magnetic bearing compressor was developed to improve performance, reliability and reduce service requirements as compared with conventional centrifugal compressor designs.

The magnetic bearing compressor has a single rotating component – the compressor shaft – levitated on a magnetic field. This cushion results in the shaft not being in contact with any other part of the compressor while operating. The compressor shaft is kept perfectly aligned in all directions by sensors at each magnetic bearing providing real-time feedback to the digital bearing control system. This cutting edge magnetic bearing technology enables outstanding energy efficiency and reliable, long-life operation.

The industry leader in environmental solutions

Daikin is committed to sustainable practices as part of our corporate culture. We believe it is the right thing to do for our customers, our community, the environment and ourselves. As the global HVAC leader, Daikin has a unique opportunity to make a difference in sustainable initiatives and continue to lead the industry in environmental solutions.

Chiller protection for long-term viability

The compressor's ability to protect itself from low power quality, and to have controlled response in power loss situations, is a feature that enhances long-term compressor viability and reduces downtime. Magnitude chillers with RideThrough can often remain on-line through minor power disturbances. In extreme or extended power disruptions, Magnitude compressors are designed to regenerate power from the spinning motor and feed that power back to the bearings and control system. This regenerative power mode allows the compressor shaft to coast down and gently reseat onto touchdown bearings.

Performance to save you millions of dollars over the life of the chiller

The Daikin Magnitude magnetic bearing centrifugal chiller is the most energy efficient chiller in its size range with part load performance as low as 0.29 kW/ton IPLV.

This amazing chiller technology has been proven effective in thousands of installations around the world. And it's up to 40% more energy efficient than standard centrifugal chillers and can **save more than \$4 million over the life of the machine.**



Flexibility to design...

What the owners of Daikin Magnitude chillers say about their units

Johnson County office building in Olathe, Kansas

We **save 57% on energy costs** compared to a similar county office building down the road. And with the high performance magnetic bearing chiller as part of our system, we earned **LEED® Gold certification** from the U.S. Green Building Council.

Neil Angrisano, AIA, Deputy Facility Manager for Johnson County



© Photography by Brad Feinkopf

Sarasota Bradenton International Airport Sarasota, Florida

The 500-ton variable speed magnetic bearing chillers will provide the airport with an electrical consumption savings estimated to be 30%. The new chiller technology also extends the chiller life, reduces annual maintenance costs, improves controls of the chiller tower operation, and is LEED® qualified.

Robert Mattingly, Vice President of Operations and Maintenance





Northbrook Junior High School in Northbrook, Illinois

We were sold on the **quiet operation** of the chillers because the plant is located next to three classrooms. The 18% reduction in energy costs with the magnetic bearing chillers helped us earn an **Energy Star® School** rating from the U. S. EPA after our mechanical system modernization.

Russ Jensen, Director of Buildings and Grounds for Northbrook School District 28



McNamara Alumni Center at the University of Minnesota in Minneapolis

The **compact design** of the chiller worked in our very tight design. Because the unit is so **quiet** we could avoid installing a housekeeping pad typically used to isolate sound, thus greatly reducing the weight and physical footprint.

Jon McCombs, Operations Manager,
McNamara Alumni Center

Flexibility to design...

Ideal for retrofit and replacement

The compact size of the Magnitude chiller makes it ideal for retrofit and replacement installations. In addition, the space that would have been used for equipment can now be put to more productive use in the facility. Most models can easily fit through double width doors without any disassembly. Even the most challenging access projects can be accommodated using our factory disassembly option.

Typical 290-ton unit

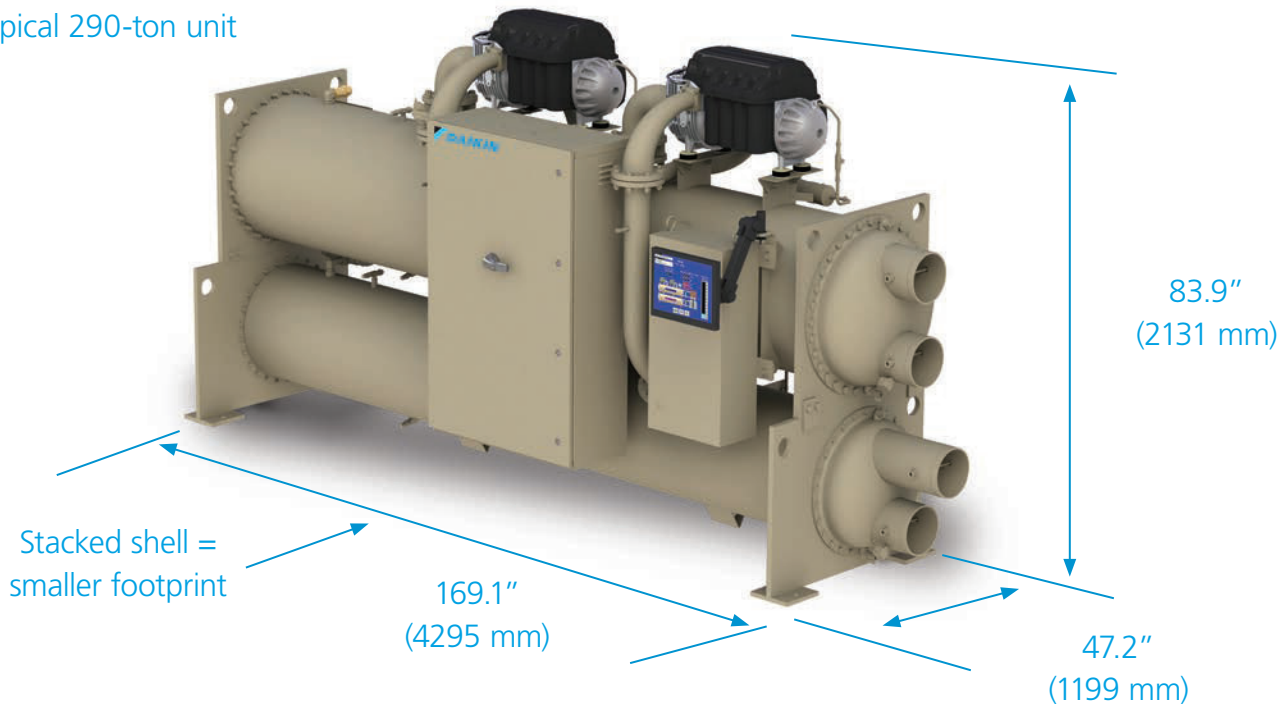

Service and maintenance savings

Because the Magnitude magnetic bearing chiller has fewer moving parts, requires no oil, nor oil-circulation equipment, it therefore requires less maintenance and service. With oil removed from the system, maintenance tasks such as oil samples, oil changes, oil filter changes, oil disposal and leaks from shaft seals are eliminated. The results are reduced operational costs and maintenance savings each and every year!

Over the life of the equipment - approximately 20 to 25 years - the total maintenance savings could be significant. Savings an owner would realize depend on maintenance practices, age and efficiency of other equipment, energy prices, etc.

Operator training for maintenance and operation of Magnitude chillers is available from the Daikin Learning Institute. Visit the Training page at www.DaikinApplied.com for details.



Our bottom line for your bottom line

Lowest total cost of ownership

Magnetic bearing centrifugal compressor eliminates the efficiency-robbing friction inherent in traditional centrifugal chiller bearings.

Integrated VFD optimizes part load efficiency, a key performance feature since most chillers operate at part load 99% of their life.

Sustainable performance assured for the operating life of the chiller. The positive pressure, oil-free design eliminates performance degradation due to non-condensables and oil contamination of the refrigerant.

Easy integration with our Open Choices™ feature using BACnet®, LonWorks® or Modbus® communications without an expensive gateway panel.

R-134a refrigerant has no ozone depletion potential and no phase-out schedule.

Reduced maintenance costs due to elimination of the oil, oil system, purge system, and shaft seals found in older technology chillers.

Small unit footprint helps the Magnitude chiller fit in buildings where space is limited, making it ideal for retrofit projects.

Unmatched unloading and efficiency is obtained through the on-board digital control system which modulates compressor speed and guide vane position for optimum performance.

Low inrush current at startup is ideal for operation with backup or emergency power systems.

Touch screen operator panel is graphically intuitive and easy to use for enhanced operator productivity. Important status and control information is available at a glance or a touch.

Seismic compliance with both IBC seismic certification standards and OSHPD pre-approval.

LEED® points can be earned from the Magnitude chiller's performance in two categories: EAc1, up to 19 points possible, and EAc4, 2 points.

Dual Compressors for redundancy and industry leading part load efficiency available in 100-400 ton and 800-1500 ton capacity.



100 to 400 ton



400 to 1500 ton



RapidRestore™ and RideThrough™ Technology

Peace of mind for mission critical applications.

A power loss could turn into a critical loss of cooling in mission critical facilities such as data centers, health care buildings or manufacturing processes. A short-term power loss can happen during power interruptions, brown-outs or utility switching operations.

With RapidRestore™ and RideThrough™ technology your Magnitude™ chiller can restart as fast as 43 seconds after power is restored. For chillers with Daikin's unique RideThrough technology, the compressor shaft may never even come to a complete stop before re-synchronizing with the VFD when power is restored. In addition, the Fast Loading option can restore 80% load cooling capacity in less than 75 seconds. So your critical cooling is restored before it's missed.

Make it a complete system for optimum system performance and reliability

1

Choose a Daikin Magnitude chiller



Magnitude magnetic bearing chiller

100 to 400 ton



Magnitude magnetic bearing chiller

400 to 1500 ton

2

Choose a Daikin air handler or terminal unit



Vision™ indoor air handler

900 to 100,000 cfm



Skyline™ outdoor air handler

900 to 65,000 cfm



Destiny™ indoor air handler

600 to 15,000 cfm



RoofPak™ outdoor air handler

4000 to 50,000 cfm



Unit ventilators

750 to 2,000 cfm



Fan coil units

200 to 3,000 cfm

DAIKIN MIDDLE EAST & AFRICA FZE

P.O. Box 18674, Jebel Ali Free Zone, Dubai, UAE

Tel: +971 (0) 4 815 9300, Fax: +971 (0) 4 815 9311

Email: info@daikinmea.com Web: www.daikinmea.com



Daikin Middle East and Africa

The present publication is drawn up by way of information only and does not constitute an offer binding upon Daikin Middle East and Africa FZE. Daikin Middle East and Africa FZE has compiled the content of this publication to the best of its knowledge. No express or implied warranty is given for the completeness, accuracy, reliability or fitness for particular purpose of its content and the products and services presented therein. Specifications are subject to change without prior notice. Daikin Middle East and Africa FZE explicitly rejects any liability for any direct or indirect damage, in the broadest sense, arising from or related to the use and/or interpretation of this publication. All content is copyrighted by Daikin Middle East and Africa FZE.