



PERFORMANCE IS
A STATE OF MIND



ABARTH 695 *biposto*

The perfect blend of maximum on-road performance and pure racing emotions. This is the Abarth 695 Biposto in a nutshell. More room for power, to emphasise its racing tradition in the best possible way. And to portray Abarth more than ever, to the nth power.

1.4 TURBO T-JET 190 HP

- T-JET 4-cylinder in-line engine, 1368 cm³
- Power 139 kW @ 5 500 rpm
- Maximum torque: 250 Nm @ 3 000 rpm (sport mode)
- Acceleration: 5.9 sec. (0-100 km/h)
- Top speed 230 km/h
- 997 kg unladen weight
- Weight to power ratio 5.2 kg/HP

MAIN STANDARD EQUIPMENT

- Front suspension with hydraulic height-adjustment with racing springs by Extreme Shox
- Rear suspension with hydraulic adjustment with racing springs by Extreme Shox
- Four-piston aluminium fixed brake callipers by Brembo
- Self-ventilated oversized 305x28 mm perforated front brake discs
- Self-ventilated 240x11 mm perforated rear brake discs
- High performance front brake pads
- Racing-derived front intercooler
- Oversized high-permeability intake kit with carbon trim by BMC
- Abarth exhaust by Akrapovic with active valve and Titanium tip
- 18" Abarth "Ultraleggera" by O.Z. alloy rims with 215/35 R18 tyres
- Abarth Corsa composite racing seats by Sabelt in leather and Alcantara
- Aluminium racing pedal board with titanium finish
- Rear bumper with aerodynamic carbon extractor
- Front bumper with carbon air conveyor
- Side skirts with carbon flap
- Oversized rear spoiler
- 7" TFT colour display instrument panel with 695 Biposto animation
- Leather-trimmed steering wheel
- Internal titanium roll-bar by Poggipolini
- Light-weight racing front and rear door panels
- Matt grey performance colour

KIT CARBONIO

- + Carbon dashboard fascia
- + Carbon front and rear door panels
- + Carbon mirror fairings and pillar trim
- + Luggage compartment with carbon trim
- + Carbon side pillars

KIT INNESTI FRONTALI

- + Dog ring gearbox
- + Mechanical self-locking differential
- + Ergal gear lever
- + Racing-derived clutch
- + Central tunnel with carbon trim
- + Carbon handbrake with titanium knob

KIT PISTA

- + MXL2 digital data logger by Aim
- + 4-point seat belts by Sabelt
- + Abarth Corsa racing seats by Sabelt in leather and Alcantara with carbon shell
- + Racing helmet





ABARTH 595 *Turismo*

With your Abarth 595 Turismo, getting noticed and making yourself heard will be an exciting experience. You'll be able to quench your thirst for speed thanks to the 160 HP engine with BMC filter, for even more power. Your desire for details that make the difference will also be satisfied to the full. This is because the Abarth 595 represents a small scale version of the greatest expression of "Granturismo Made in Italy". This is also because it offers the perfect compromise between performance and style, teaming an astounding power with stylistic set-up that will win you over at first glance.

HATCHBACK

1.4 TURBO T JET 160 HP

- T-JET 4-cylinder in-line engine, 1368 cm³
- Power 118 kW @ 5500 rpm
- Maximum torque: 230 Nm @ 3000 rpm (sport mode)
- Acceleration 7.4 sec. (0-100 km/h) (7.6 sec. with sequential robotized gearbox)
- Top speed 210 km/h (manual gearbox)
- Available with sequential robotized gearbox and steering wheel with shift paddle
- Weight to power ratio 6.5 kg/HP

MAIN STANDARD EQUIPMENT

- Abarth chromed steel rear twin exhaust in sight
- TTC (Torque Transfer Control)
- Koni rear suspension with FSD (Frequency Selective Damping) technology
- Abarth braking system with self-ventilated perforated front brake discs
- High performance front brake pads
- 17" Touring alloy rims with 205/40 R17 tyres
- Abarth leather racing seats
- Racing pedal board with Alutex footrest and kick plate
- 7" TFT colour display instrument panel
- Leather steering wheel with integrated controls
- Blue&Me™ hands-free system with USB port, Bluetooth and MP3 radio
- Fog lights
- Chromed exterior trim and dashboard fascia in body colour



CONVERTIBLE

1.4 TURBO T JET 160 HP

- T-JET 4-cylinder in-line engine, 1368 cm³
- Power 160 HP 118 kW @ 5500 rpm
- Maximum torque: 230 Nm @ 3000 rpm (sport mode)
- Acceleration 7.4 sec. (0-100 km/h) (7.6 sec. with sequential robotized gearbox)
- Top speed 210 km/h (manual gearbox)
- Available with sequential robotized gearbox and steering wheel with shift paddle
- Weight to power ratio 6.5 kg/HP

MAIN STANDARD EQUIPMENT

- Abarth chromed steel rear twin exhaust in sight
- TTC (Torque Transfer Control)
- Koni rear suspension with FSD (Frequency Selective Damping) technology
- Abarth braking system with self-ventilated perforated front brake discs
- High performance front brake pads
- 17" Touring alloy rims with 205/40 R17 tyres
- Abarth leather racing seats
- Racing pedal board with Alutex footrest and kick plate
- 7" TFT colour display instrument panel
- Leather steering wheel with integrated controls
- Blue&Me™ hands-free system with USB port, Bluetooth and MP3 radio
- Fog lights
- Chromed exterior trim and dashboard fascia in body colour
- Electrically operated soft top



TECHNICAL SPECIFICATIONS

	695 BIPOSTO 190 HP		595 TURISMO 160 HP	
	MANUAL/DOG RING		MANUAL	SEQUENTIAL ROBOTIZED
ENGINE				
ENGINE TYPE, DISPLACEMENT, CYLINDERS, VALVES	T-JET, 1368 CM³, 4-CYLINDER IN-LINE, 4 VALVES PER CYLINDER		T-JET, 1368 CM³, 4-CYLINDER IN-LINE, 4 VALVES PER CYLINDER	
MAXIMUM POWER	190 HP (140 KW) A 5500 G/M		160 HP (118 KW) A 5500 G/M	
MAXIMUM TORQUE	250 NM A 3000 G/M		206 NM A 2000 G/M (SPORT MODE)	230 NM A 2000 G/M (SPORT MODE)
TURBOCHARGER	GARRETT GT 1446		IHI RHF3-P	
TRANSMISSION				
5-SPEED GEARBOX	MANUAL/DOG RING		MANUAL	SEQUENTIAL ROBOTIZED
EXHAUST AND AIR FILTER				
EXHAUST PIPE	ABARTH EXHAUST BY AKRAPOVIC WITH ACTIVE VALVE		ABARTH CHROMED TWIN EXHAUST	
FILTER	HIGH PERFORMANCE BMC FILTER WITH CARBON TRIM		HIGH PERFORMANCE BMC FILTER	
ELECTRICAL SYSTEM				
BATTERY	250 A / 50 AH		250 A / 50 AH	
PERFORMANCE				
TOP SPEED (KM/H)	230		210	209
ACCELERATION 0 - 100 KM/H	5,9		7,4	7,6
FUEL CONSUMPTION EMISSIONS LEVEL				
URBAN CONSUMPTION (L/100 KM)	8,2		7,9	7,6
EXTRA-URBAN CONSUMPTION (L/100 KM)	5,1		4,9	4,7
COMBINED CONSUMPTION (L/100 KM)	6,2		6,0	5,8
CO ₂ EMISSIONS (G/KM)	145		139	134
EMISSIONS STANDARD	EURO 6		EURO 6	
FRONT				
SUSPENSION	MACPHERSON WITH ANTI ROLL-BAR		MACPHERSON WITH ANTI ROLL-BAR	
REAR	TORSION BEAM WITH ANTI ROLL-BAR		TORSION BEAM WITH ANTI ROLL-BAR	
RIDE	LOWERED RACING		LOWERED RACING	
SHOCK ABSORBERS				
FRONT	HEIGHT-ADJUSTABLE EXTREME SHOX WITH RACING SPRINGS		ADAPTIVE WITH FSB VALVE (FREQUENCY SELECTIVE DAMPING)	
REAR	HEIGHT-ADJUSTABLE EXTREME SHOX WITH RACING SPRINGS		KONI WITH FREQUENCY SELECTIVE DAMPING (FSD)	
BRAKES				
FRONT (MM)	SELF-VENTILATED 305X28 MM PERFORATED FRONT BRAKE DISCS, BREMBO ALUMINIUM FIXED BRAKE CALLIPERS		SELF-VENTILATED AND PERFORATED Ø 284X22 MM FRONT BRAKE DISCS	
REAR (MM)	PERFORATED Ø 240X11 REAR BRAKE DISCS		Ø 240X11 REAR BRAKE DISCS	
ALLOY				
WHEEL RIMS	18" WITH 215/35 TYRES		17" WITH 205/40 TYRES	

DIMENSIONS

695 BIPOSTO

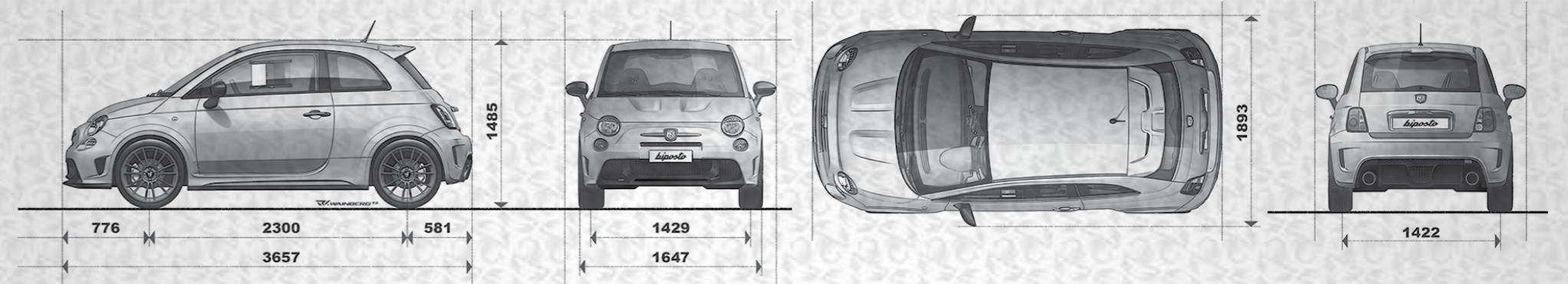

595 HATCHBACK

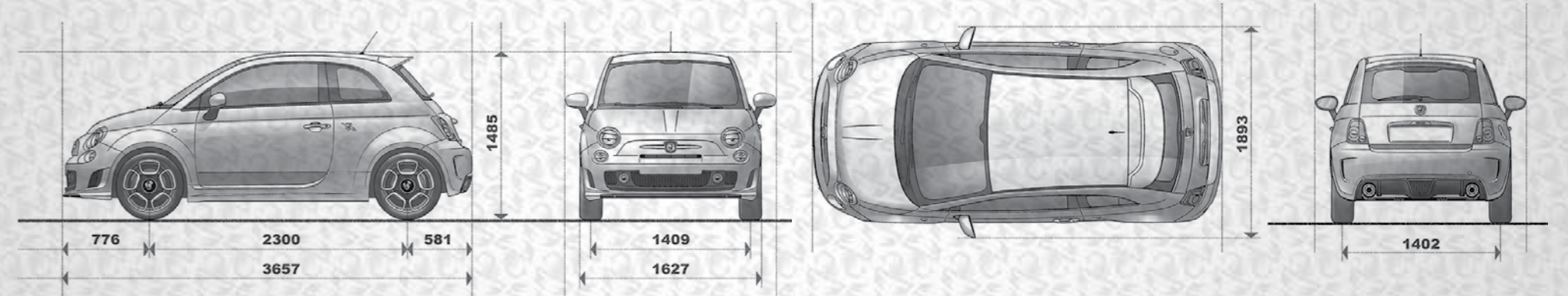

595 CONVERTIBLE



695 BIPOSTO EQUIPMENT

EXTERIOR	695 BIPOSTO
TINTED REAR AND REAR DOOR WINDOWS	S
OVERSIZED REAR SPOILER	S
18" ABARTH "ULTRALEGGERA" BY O.Z. ALLOY RIMS WITH 215/35 R18 TYRES	S
TITANIUM EXTERIOR TRIM	S
MATT PERFORMANCE GREY	S
REAR BUMPER WITH AERODYNAMIC CARBON EXTRACTOR	S
FRONT BUMPER WITH CARBON AIR CONVEYOR	S
SIDE SKIRTS WITH CARBON FLAP	S
ELECTRIC DOOR MIRRORS IN MATCHING BODY COLOUR	S
MATT GREY PAINT	S
CUSTOMISABLE BIPOSTO PLATE	S
REAR 695 BIPOSTO LOGO	S

INTERIOR

HEIGHT-ADJUSTABLE STEERING WHEEL	S
ALUMINIUM RACING PEDAL BOARD WITH TITANIUM FINISH	S
ALUMINIUM FOOTREST ON PASSENGER'S SIDE	S
FOOTREST ON DRIVER'S SIDE	S
FOOTREST ON PASSENGER'S SIDE	S
MATT PERFORMANCE GREY DASHBOARD FASCIA	S
LUGGAGE COMPARTMENT FLOOR COVER	S
TITANIUM PAINTED INTERIOR HANDLE	S
KICK PLATES	S
ABARTH CORSA COMPOSITE RACING SEATS BY SABELT IN LEATHER AND ALCANTARA	S
RADIO COMPARTMENT TRIM	S
MESH TRIM FOR UPPER VENTS	S
LIGHT-WEIGHT RACING FRONT AND REAR DOOR PANELS	S
INDIRECT TPMS WITH SELECTIVE INDICATION OF THE TYRE WITH LOWER THAN NORMAL PRESSURE	S
7" TFT COLOUR DISPLAY INSTRUMENT PANEL WITH 695 BIPOSTO ANIMATION	S

PERFORMANCE

RACING-DERIVED FRONT INTERCOOLER	S
HIGH-PERMEABILITY DYNAMIC INTAKE KIT WITH CARBON TRIM BY BMC	S

PERFORMANCE

695 BIPOSTO	695 BIPOSTO
FRONT AND REAR SUSPENSION WITH HYDRAULIC HEIGHT-ADJUSTMENT WITH RACING SPRINGS BY EXTREME SHOX	S
RACING SPRINGS BY EXTREME SHOX	S
ABARTH EXHAUST BY AKRAPOVIC WITH ACTIVE VALVE AND TITANIUM TIP	S
FOUR-PISTON ALUMINIUM FIXED BRAKE CALLIPERS BY BREMBO	S
SELF-VENTILATED OVERSIZED 305X28 MM PERFORATED FRONT BRAKE DISCS	S
SELF-VENTILATED 240X11 MM PERFORATED REAR BRAKE DISCS	S
HIGH PERFORMANCE FRONT BRAKE PADS	S

COMFORT AND FUNCTIONALITY

REMOTE CONTROL FOR DOOR OPENING/LOCKING	S
HEATED REAR WINDOW	S
HEAT-REFLECTING WINDOWS	S
FUEL FILLER CAP WITH KEY	S
ELECTRIC FRONT WINDOWS	S
5-SPEED MANUAL GEARBOX	S
ELECTRONIC EXHAUST VALVE CONTROL MODULE	S

SAFETY

KNEE BAG ON DRIVER'S SIDE	S
TYRE INFLATION/REPAIR KIT	S
DRIVER AIRBAG	S
PASSENGER AIRBAG WITH PASSENGER AIRBAG DEACTIVATION SUB MENU AND INDICATION ON INSTRUMENT PANEL	S
HEAD PROTECTION SIDE WINDOW BAGS	S
ELECTRONIC STABILITY PROGRAMME INCLUDING: ASR, HILL HOLDER, MSR, HBA	S
ROLL BAR - ANTI-INTRUSION NET FOR LUGGAGE	S
ELECTRIC POWER STEERING WITH "DUAL DRIVE" SYSTEM COMPLETE WITH CONTROL (SPORT BUTTON)	S

KITS

KIT 124 SPECIALE	O
KIT CARBONIO	O
RACING WINDOWS	O
KIT PISTA	O
KIT INNESTI FRONTALI	O

595 RANGE EQUIPMENT

EXTERIOR

	HATCHBACK	CONVERTIBLE
	595 TURISMO	595 TURISMO
BODY-COLOURED WHEEL ARCH SIDE STRIPS	S	S
ABARTH CHROMED TWIN EXHAUST	S	S
ABARTH EXHAUST WITH 'RECORD MONZA' FOUR-OUTLET VALVE	O	O
ABARTH EXHAUST WITH 'RECORD MODENA' TWO-OUTLET VALVE	O	O
UNPAINTED BRAKE CALLIPERS	-	-
RED BRAKE CALLIPERS	S	S
YELLOW BRAKE CALLIPERS	O	O
BLACK BRAKE CALLIPERS *	O	O
FOUR-PISTON GREY ALUMINIUM FIXED BRAKE CALLIPERS BY BREMBO	-	-
FOUR-PISTON RED ALUMINIUM FIXED BRAKE CALLIPERS BY BREMBO	-	-
FOUR-PISTON YELLOW ALUMINIUM FIXED BRAKE CALLIPERS BY BREMBO	-	-
FOUR-PISTON BLACK ALUMINIUM FIXED BRAKE CALLIPERS BY BREMBO *	-	-
SIDE SKIRTS	S	S
TINTED REAR WINDOWS	S	S
REAR SPOILER	S	S
HIDDEN AERIAL WITH 595 CAP ON ROOF	O	-
"SKY DOME" GLAZED SUNROOF	O	-
"OFFICINA RED" PASTEL COLOUR	S	S
"CAMPOVOLO GREY" PASTEL COLOUR	O	O
"GARA WHITE" PASTEL COLOUR	O	O
"LEGGENDA LIGHT BLUE" PASTEL COLOUR	O	O
"PISTA GREY" PASTEL COLOUR	O	O
"RALLY BEIGE" PASTEL COLOUR	O	O
"SCORPIONE BLACK" METALLIC COLOUR	O	O
"RECORD GREY" METALLIC COLOUR	O	O
"PODIO BLUE" METALLIC COLOUR*	O	O
"TROFEO GREY" METALLIC COLOUR	O	O
"CORDOLO RED" THREE-LAYER COLOUR	O	O
"PISTA GREY/CAMPOVOLO GREY" BI-COLOUR	O	O
"SCORPIONE BLACK/GARA WHITE" BI-COLOUR	O	O
"PISTA GREY/OFFICINA RED" BI-COLOUR	O	O
"RALLY BEIGE/TROFEO GREY" BI-COLOUR	O	O
"RALLY BEIGE/OFFICINA RED" BI-COLOUR	O	O
"PISTA GREY/LEGGENDA LIGHT BLUE" BI-COLOUR	O	O
EXTERIOR TRIM AND DASHBOARD FASCIA IN TAR COLD GREY	-	-
CHROMED EXTERIOR TRIM AND DASHBOARD FASCIA IN BODY COLOUR	S	S
CHROME MIRROR FAIRINGS	O	O

S STANDARD / O OPTIONAL / - NOT AVAILABLE

595 RANGE EQUIPMENT

	HATCHBACK	CONVERTIBLE
INTERIOR	595 TURISMO	595 TURISMO
ABARTH LEATHER STEERING WHEEL	S	S
HEIGHT-ADJUSTABLE STEERING WHEEL	S	S
ABARTH LEATHER STEERING WHEEL WITH ITALIAN FLAG TARGET	-	-
50/50 SPLIT REAR SEAT BACKREST	S	S
HEIGHT-ADJUSTABLE DRIVER'S SEAT	S	S
PASSENGER SEAT WITH MECHANICAL MEMORY	S	S
RACING PEDAL UNIT AND FOOTREST	S	S
HEIGHT-ADJUSTABLE REAR HEADRESTS	S	S
ABARTH FABRIC RACING SEATS	-	-
ABARTH LEATHER RACING SEATS	S	S
ABARTH CORSA BY SABELT SEATS IN BLACK FABRIC	-	-
ABARTH CORSA BY SABELT SEATS IN LEATHER AND ALCANTARA	O	O
COMFORT AND FUNCTIONALITY		
MANUAL CLIMATE CONTROL WITH POLLEN FILTER	S	S
AUTOMATIC CLIMATE CONTROL	O	O
FOG LIGHTS	S	S
DUALDRIVE ELECTRIC POWER STEERING WITH SPORT FUNCTION	S	S
ELECTRIC WINDOWS AND ELECTRIC DOOR LOCKING	S	S
DOOR MIRRORS WITH DEFROSTING	S	S
DOOR OPENING/CLOSING AND TAILGATE LOCKING/UNLOCKING REMOTE CONTROL	S	S
FUEL FILLER CAP WITH KEY	S	S
FIX&GO	S	S
SMOKERS' KIT	S	S
DAY/NIGHT ELECTROCHROMIC INTERIOR REAR-VIEW MIRROR	O	O
ABARTH SEQUENTIAL ROBOTIZED GEARBOX	O	O
WIND STOP	-	O
REAR PARKING SENSORS	O	S
AUDIO AND INFOTAINMENT		
RADIO/CD/MP3-PLAYER WITH STEERING WHEEL CONTROLS, 4 X 40 W SPEAKERS, 2 X 30 W TWEETERS	S	S
BLUE&ME™ HANDS-FREE SYSTEM WITH USB PORT, BLUETOOTH AND STEERING WHEEL CONTROLS	S	S
"INTERSCOPE" HI-FI AUDIO SYSTEM WITH 4 SPEAKERS, 2 TWEETERS	O	O
SET-UP FOR SATNAV	O	O

S STANDARD / O OPTIONAL / - NOT AVAILABLE

	HATCHBACK	CONVERTIBLE
SAFETY	595 TURISMO	595 TURISMO
FRONT AIRBAGS, DRIVER AND PASSENGER SIDE	S	S
DRIVER KNEE BAG	S	S
SIDE AIRBAGS	S	S
WINDOW BAGS	S	S
ABS + EBD	S	S
ESP, ASR, MSR, HBA AND HILL HOLDER	S	S
TTC (TORQUE TRANSFER CONTROL)	S	S
XENON HEADLIGHTS	S	S
EXTERIOR CUSTOMISATION		
ABARTH STYLING KIT (SIDE STICKERS AND MIRROR FAIRINGS) RED, WHITE OR BLACK	O	O
MATT GREY ABARTH STYLING KIT (SIDE)	O	O
MATT RED ABARTH STYLING KIT (SIDE)	O	O
MATT WHITE ABARTH STYLING KIT (SIDE)	O	O
MATT BLACK ABARTH STYLING KIT (SIDE)	O	O
RED ABARTH CHEQUERED ROOF STICKER	O	-
WHITE ABARTH CHEQUERED ROOF STICKER	O	-
BLACK ABARTH CHEQUERED ROOF STICKER	O	-
RED ABARTH SCORPION STICKER	O	O
WHITE ABARTH SCORPION STICKER	O	O
BLACK ABARTH SCORPION STICKER	O	O
CHROME KIT (CHROME HANDLES, BONNET TRIM, DOOR FRAME, TAILGATE HANDLE AND MIRROR FAIRINGS)	-	-

* ONLY WHEN FITTED WITH ABARTH LEATHER SEATS

ABARTH SEATS

ABARTH SEATS



Black fabric
grey stitching
(standard on the 595)



Black leather
(standard on the Turismo)



Red leather



Natural leather



Grey leather

RIMS



17" alloy rims
Sport



17" alloy rims
Touring



18" alloy rims
Ultraleggera
(Biposto)

PASTEL



Gara White



Rally Beige



Leggenda Light Blue

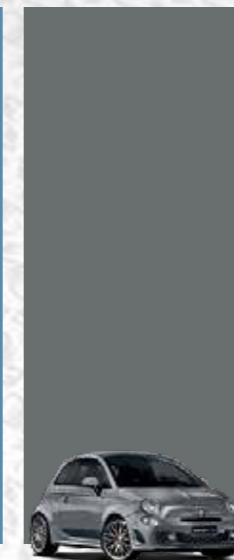

Campovolo Grey



Pista Grey



Officina Red

METALLIC



Record Grey



Trofeo Grey



Scorpione Black

THREE-LAYER



Cordolo Red

MATT



Performance Grey
Only available on the 695



**A WORLD OF PERFORMANCE
SINCE 1949**

DISCLAIMER:

The information contained in this brochure is provided as is and without any warranties of any kind, whether expressed or implied, including but not limited to, implied warranties of satisfactory quality, fitness for a particular purpose and/or correctness. The contents of this brochure is for general information purposes only and does not constitute advice. Fiat Chrysler Automobiles US LLC does not represent or warrant that the information and/or specifications contained in this brochure are accurate, complete or current and specifically stipulate that certain vehicle details and specifications contained in this brochure may differ in available models. Therefore, Fiat Chrysler Automobiles US LLC makes no warranties or representations regarding the use of the content, details, specifications or information contained in this brochure in terms of their correctness, accuracy, adequacy, usefulness, timeliness, reliability or otherwise, in each case to the fullest extent permitted by law.

May 2016 (OB 04 16458) • Part number: xxxxxxxx