

\$2.50



**MERITOR**<sup>™</sup>

A Heritage of Rockwell Technology

# Lubrication

---

**Maintenance Manual No. 1**  
**Revised 3-99**

# Service Notes



This manual contains Meritor's grease and oil lubricant specifications, lubrication procedures and intervals, and product capacities. The information contained in this manual was current at the time of publication and is subject to change without notice or liability.

You must follow company procedures and understand all procedures and instructions before you begin to service or repair a unit. Some procedures require the use of special tools for safe and correct service. Failure to use special tools when required can cause serious personal injury to service personnel, as well as damage equipment and components.

Meritor uses the following notations to warn the user of possible safety issues and to provide information that will prevent damage to equipment and components.



## **WARNING**

*A **WARNING** indicates that you must follow a procedure exactly. Otherwise, serious personal injury can occur.*



## **CAUTION**

*A **CAUTION** indicates that you must follow a procedure exactly. Otherwise, damage to equipment or components can occur. Serious personal injury can also result, in addition to damaged or malfunctioning equipment or components.*

**NOTE:** A NOTE indicates an operation, procedure or instruction that is important for proper service. A NOTE can also supply information that can help to make service quicker and easier.



*This symbol indicates that you must tighten fasteners to a specific torque value.*

## Visit Our Web Site

Visit the Technical Library section of [www.meritorauto.com](http://www.meritorauto.com) for additional product and service information on Meritor's Heavy Vehicle Systems component lineup.

## Drivetrain Plus™ Technical Electronic Library (TEL) on CD

The CD includes product and service information on Meritor's Drivetrain Plus™ component lineup. \$20. Order TP-9853.

## Video

*Lubrication*  
T-99398V. \$20.

## How to Order

Call Meritor's Customer Service Center at 800-535-5560.



---

<b>References</b> .....	ii
<b>Section 1</b> Introduction .....	1
<b>Section 2</b> Clutch .....	4
<b>Section 3</b> Driveline .....	6
<b>Section 4</b> Front Driving Axle .....	10
<b>Section 5</b> Front Non-Driving Axle .....	14
Easy-Steer Plus™ Front Axle .....	15
<b>Section 6</b> On-Highway Brakes .....	19
LX500/MX500 Cam Brakes .....	21
<b>Section 7</b> Planetary Drive Axle .....	23
<b>Section 8</b> Rear Drive Axle .....	27
<b>Section 9</b> Trailer Axle .....	38
TB Series Trailer Axles with Unitized Hubs .....	38
<b>Section 10</b> Transfer Case .....	42
<b>Section 11</b> Transmission .....	45
<b>Section 12</b> Wheel Bearings and Wheel End .....	49
<b>Section 13</b> List of Lubricants .....	52



# References

For more complete service information on Meritor components, consult the publications below. To order technical literature, refer to the Service Notes page on the inside cover of this manual.

**Publication No. and Title**

<b>Lubrication Information</b>	
TP-90114	Transmission Bulletin No. 9 Lubricant Specifications
TP-9303	Advanced Lube Rear Drive Axles
TP-9539	Approved Rear Drive Axle Lubricants

<b>Clutches</b>	
25A	Clutches

<b>Front Driving Axles</b>	
5	Single Reduction Differential Carriers
6	Double Reduction Drive Unit (Front Mounted Type)
12	Front Driving Axles-Heavy Duty
12A	Front Driving Axles-Light Duty

<b>Front Non-Driving Axles</b>	
2	Front Non-Drive Steering Axles
2A	Easy Steer Plus™ Front Axle

<b>On-Highway Brakes</b>	
4	Cam Brakes
4B	Automatic Slack Adjusters
4L	Wet Disc Brakes
4M	Air Disc Brakes
4R	Wedge Brakes
MM-96173	Q Plus LX500/MX500 Cam Brakes

<b>Off-Highway Brakes</b>	
4	Cam Brakes
4L	Wet Disc Brakes
4H	Hydraulic and Mechanical Drum Brakes

<b>Planetary Drive Axles</b>	
5	Single Reduction Differential Carriers
5B	Tandem Axle Forward Rear Drive Units
5E	Tandem Axle Forward Rear Drive Units
5P	Tandem Axle Forward Rear Drive Units
9	Planetary Axle Wheel Ends

**Publication No. and Title**

<b>Single Rear Axles</b>	
5	Single Reduction Differential Carriers
6	Double Reduction Drive Unit (Front Mounted Type)
6C	270 Series Double Reduction Differential Carriers
7	Two-Speed Double-Reduction Drive Unit
7A	Hypoid Planetary Two-Speed Differential Carriers

<b>Tandem Rear Axles</b>	
23A	Bus and Coach Front and Rear Axles
5	Single Reduction Differential Carriers
5A	Single Reduction Rear Differential Carriers
5B	Tandem Axle Forward Rear Drive Units
5C	Tandem Axle Forward Rear Drive Units
5E	Tandem Axle Forward Rear Drive Units
5L	Tandem Axle Forward Rear Drive Units
5P	Tandem Axle Forward Rear Drive Units
6A	Double Reduction Drive Unit
6B	Double Reduction Drive Unit
6C	270 Series Double Reduction Differential Carriers

<b>Trailer Axles</b>	
14	Trailer Axles
TP-96175	Servicing Rockwell's TB Series Trailer Axles with Unitized Hub Assemblies

<b>Transfer Cases</b>	
3	Transfer Cases—Three Shaft Design
3A	Transfer Cases—(Cover Leaf Design)— Four Shaft Type
3B	T-215 Series Transfer Cases
3D	T-2111 Series Transfer Cases

<b>Transmissions</b>	
26A	Nine-, Ten- and Thirteen-Speed Manual Transmissions
26B	Air Shift Systems Nine-Speed Manual Transmissions
26D	Air Shift Systems Thirteen-Speed Manual Transmissions

## Introduction

In this manual, Meritor recommends specific grease and oil lubricants, lubrication procedures and intervals, and product capacities that will enable you to correctly lubricate and maintain Meritor components.

To help reduce friction, prevent dirt and wear particles from affecting moving parts of components, protect components from damage and help to ensure maximum life for Meritor components:

- Use a specified lubricant or grease from a manufacturer that provides quality products and complete application instructions.
- Follow recommended lubrication intervals and procedures.

## Oil Lubricants

There are three categories of oil lubricants: Petroleum oil, Full Synthetic oil and Semi-Synthetic oil. Both full synthetic and semi-synthetic oils retain their lubrication properties longer than petroleum oil.

- **Petroleum Oil** is derived from crude oil. Crude petroleum oil also yields combustible fuels and a wide range of petroleum chemicals.
- **Full Synthetic Oil** uses a man-made-base oil with predictable physical properties. Full synthetic oil contains no refined petroleum-based fluids.
- **Semi-Synthetic Oil** contains a mixture of petroleum-based and synthetic fluids that can help extend service intervals, improve cold weather properties and reduce volatility.

## Viscosity

Select the proper viscosity oil for a specific Meritor component from the charts in each section of this manual. When more than one lubricant is listed, choose an oil viscosity that is suitable for the expected outside temperature.

- Use **multigrade oils** when vehicles operate in both cold and warm weather between oil changes.
- Use **low viscosity single grade oils** only in cold climates. **Single grade 75W oils are not approved for use in drive axles where ambient temperatures exceed 40°F (4°C).**
- Use **multigrade oil** for drive axles only. The hypoid gearing requires a GL-5 oil with Extreme Pressure (EP) additives to provide adequate lubricant film protection that prevents gear failure.

### **CAUTION**

***Do not use thinning agents such as kerosene, gasoline or any other diluents to lower the viscosity of recommended lubricants. Thinning agents damage the lubricant and can be a safety hazard.***

**NOTE:** Oil viscosity grades and classifications are provided by the SAE (Society of Automotive Engineers) and the API (American Petroleum Institute).

## Oil Changes

Determine the oil change interval by analyzing oil samples taken at specified intervals or mileage. However, the final recommended scheduled interval may be due to service duty, regardless of vehicle mileage or established change schedule.

## Recommended Oil Drain Conditions Based On Used-Oil Analyses

### Differential Oils (Hypoid Gear Oils)

Drain and replace used differential oil that does not meet with the following used-oil analyses. Replace the drained oil with Meritor-specified oil for hypoid drive axle use.

#### Used-Oil Analyses (ppm=parts per million)

Iron (Fe)	If level is between 1000 ppm and 1500 ppm, resample the oil. If resampling indicates that iron level is above 1000 ppm, drain and replace the oil.  If level is above 1500 ppm, drain and replace the oil.
Silicon (Si)	If level is greater than 100 ppm, drain and replace the oil.
Water (H <sub>2</sub> O)	If level is greater than 0.3%, drain and replace the oil.
Phosphorus (P)	If level is <u>less than</u> 900 ppm, it is possible that the oil is not a GL-5 gear oil. Contact the lubricant manufacturer or Meritor Materials Engineering to determine the expected phosphorus level of a new oil sample. Only GL-5 type gear oils are approved for use in Meritor differentials.
Toluene Insolubles	If level is greater than 0.100 wt.%, drain and replace the oil.

## Manual Transmission Oils

If used transmission oil analyses indicate that any one of these criteria is not met, drain the used oil and replace it with an oil that is recommended for manual transmissions.

#### Used-Oil Analyses (ppm = parts per million)

Iron (Fe)	If level is greater than 500 ppm, drain and replace the oil.
Silicon (Si)	If level is greater than 100 ppm, drain and replace the oil.
Water (H <sub>2</sub> O)	If level is greater than 0.3%, drain and replace the oil.

## Grease Lubricants

- Grease lubricants contain three substances: **oil**, a **thickener base** and **additives**.
- The oil lubricates. The thickener (base) holds the oil in place and releases it to provide the necessary lubrication. The additives enhance the characteristics of the oil and thickener. Extreme Pressure (EP) additives help prevent scoring, galling and welding of moving parts.
- The thickener may be simple or complex soap (lithium, calcium, aluminum, etc.), organic (polyurea) or inorganic (clay).
- **Do not** mix different types of greases. The possibility of incompatible greases may reduce the lubricating ability of the greases.
- An important property of a grease is its **dropping point**, the temperature that it changes from a semi-solid state to a liquid state. However, the operating temperature of a specific grease is not determined solely by the dropping point. Other properties such as resistance to change in consistency and chemical deterioration at high temperatures must be considered.



## NLGI Labels

Grease lubricants are classified by the National Lubricating Grease Institute (NLGI) and given grade numbers based on the consistency of the grease. The NLGI has developed a new specification and classification for automotive greases based on the application. The NLGI issues licensed symbols (as shown above) designating the application for which the grease is approved.

## Extreme Pressure (EP) Lubricants

### CAUTION

***Do not use multi-viscosity or Extreme Pressure (EP) GL-5 gear oils in the manual transmission. Damage to the transmission will result. Refer to Section 11 in this manual for the correct transmission oil.***

“EP” is an abbreviation used by lubricant manufacturers for Extreme Pressure lubricants. EP lubricants contain special additives that provide extra anti-wear protection to heavily-loaded parts. Meritor requires either EP greases or EP oils in various applications. Refer to the specific section in this manual for recommendations. Approved hypoid gear oils contain EP additives that protect against tooth scoring and surface fatigue.

## Section 2 Clutch



### Release Bearing

#### **WARNING**

*To prevent serious eye injury, always wear safe eye protection when you perform vehicle maintenance or service.*

#### **CAUTION**

*Make sure the inspection cover on the clutch housing is used. If an inspection cover is not used, dirt and contaminants enter the clutch housing and damage the clutch.*

1. Remove the inspection cover on the clutch housing.
2. Clean all grease fittings prior to lubrication.

**NOTE:** Do not overgrease.

3. Properly lubricate the release bearing. Apply grease to the grease fitting on the release bearing until you can see a small amount of grease coming out of the bearing housing.
4. Apply grease to the release yoke tips where they contact the bearing housing. Also apply grease to the exposed transmission input shaft between the bearing housing and the transmission input bearing retainer to lubricate the release sleeve bushing.
5. If the release bearing is equipped with a lube tube, be sure that you can see grease coming out of the bearing housing, which ensures that lubricant is reaching the bearing. Be sure that the lube tube is secured and not damaged.
6. Use the same procedure for extended maintenance clutches.
7. Install the inspection cover. Meritor recommends using a high temperature, multipurpose wheel bearing grease (Meritor Specification O-661), but use the lubricant recommended by the manufacturer of the vehicle. **Figure 2.1.**

Figure 2.1

#### RELEASE BEARING LUBRICATION POINTS

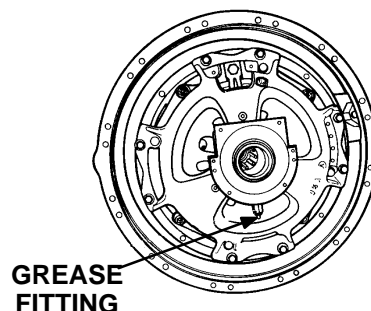

### Bell Housing

1. Clean all grease fittings prior to lubrication.
2. Grease the release fork cross shaft by applying grease to each fitting on the bell housing until a small amount of grease purges out. Use the specified lubricant at the recommended interval. Refer to the lubricant specifications and maintenance intervals of the vehicle manufacturer.

**Figure 2.2.**

Figure 2.2

#### BELL HOUSING GREASE FITTINGS – BOTH SIDES

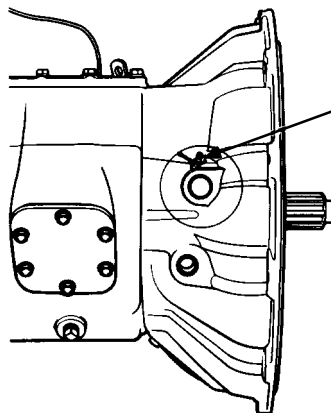



## Clutch Linkage

**NOTE:** Some vehicle manufacturers may use “lubed-for-life” ball joints in the clutch linkage. See the lubricant information of the vehicle manufacturer.

You must lubricate each pivot point on the linkage according to the vehicle manufacturer’s procedure. Use the specified lubricant at the recommended interval. Refer to the lubricant specifications and maintenance intervals. **Figure 2.3.**

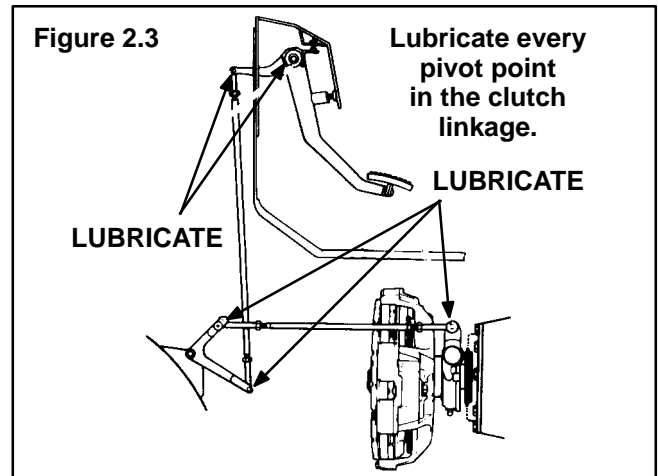

## Greasing Interval and Specifications

Component	Greasing Interval	Grease	Meritor Specification	NLGI Grade	Grease Description	Outside Temperature
Release Bearing	①	High Temperature Multi-Purpose Wheel Bearing Grease	O-661	3	Lithium Complex	Down to -40°F (-40°C)
Bell Housing	①	②	----	----	----	----
Clutch Linkage	①	②	----	----	----	----

- ① Use the interval specified by the vehicle manufacturer or the fleet, but make sure the release bearing is greased once per month.
- ② Use the grease specified by the vehicle manufacturer.

## Approved Lubricants

Lubricant	Recommendation
Clutch Bearing Grease	Exxon Unirex N Grade 3 (NLGI Grade No. 3, Lithium Complex)

## General Information

There are different styles of drivelines available and each has different lubrication requirements and procedures.

Industry Name/Description	Series	Type	Lubrication Requirements
Standard or Conventional Driveline	16N 17N 176N 18N 16T 17T 176T 18T	Full Round Easy Service or 1/2 Round	Splines and Universal Joints
92N Permalube	92N	Wing Style	Splines Only
RPL Series (Meritor Permalube)	RPL 25 RPL 20	Combination Wing and Full Round	None

## Standard/Conventional Driveline Universal Joint (Figure 3.1.)

### **WARNING**

*To prevent serious eye injury, always wear safe eye protection when you perform vehicle maintenance or service.*

1. Check the driveline for looseness. If loose, service the driveline as necessary.
2. Clean all grease fittings prior to lubrication.
3. Apply the specified grease at the grease fitting on the universal joint. Apply grease until new grease purges from all four seals.
4. If new grease does not purge at all the seals, loosen the problem bearing cap bolts and regrease until all four cups purge. If new grease still does not purge, replace the universal joint.

## Standard/Conventional Driveline Slip Yoke and Splines

1. Check the driveline for looseness. If loose, service the driveline as necessary.
2. Cover the vent hole in the welch plug with a finger.
3. Apply the specified grease at the grease fitting on the slip yoke until the grease purges from the dust seal.

**Figure 3.1** Combination Full-Round/Easy Service™

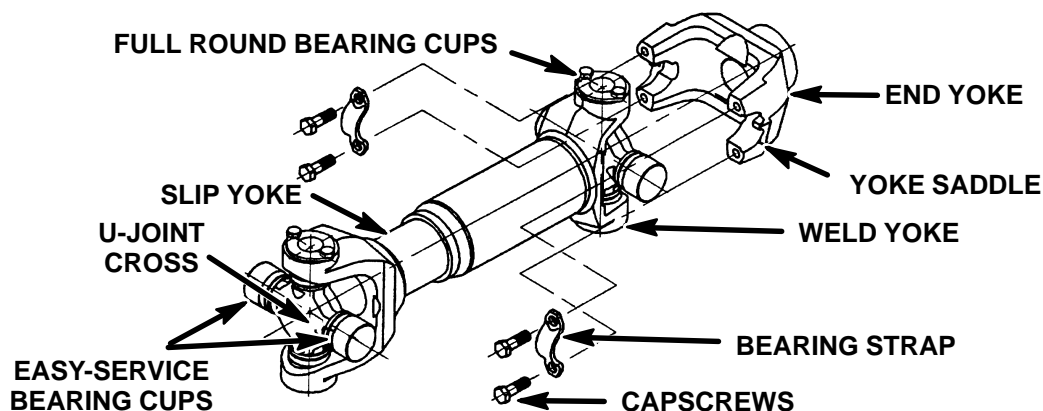

## RPL Series Permalube™ Driveline Universal Joint, Slip Yoke and Splines

The universal joint, slip yoke, and splines are permanently lubricated and sealed and do not require regular lubrication. **Figure 3.2.**

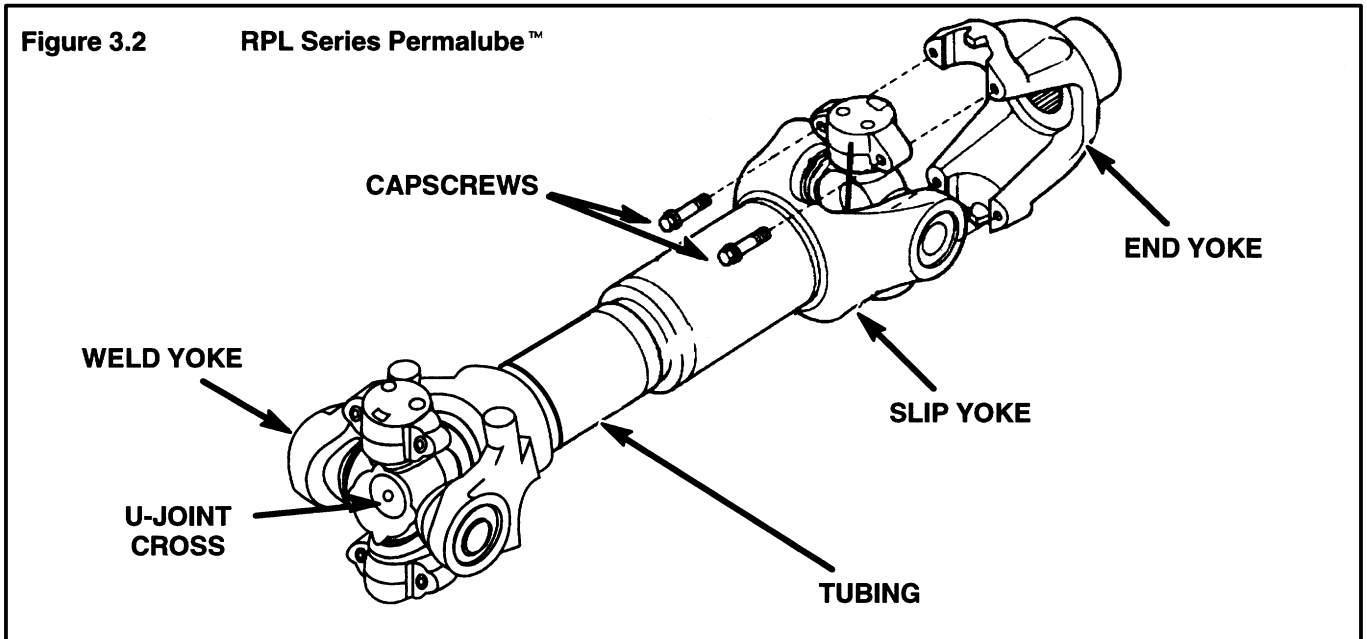

## 92N Permalube™ Driveline Universal Joint

The universal joint is permanently lubricated and does not require regular maintenance. **Figure 3.3.**

## 92N Permalube™ Driveline Slip Yoke and Splines

### **WARNING**

*To prevent serious eye injury, always wear safe eye protection when you perform vehicle maintenance or service.*

1. Check the driveline for looseness. If loose, service the driveline as necessary.
2. Clean all grease fittings prior to lubrication.
3. Cover the vent hole in the welch plug with a finger.
4. Apply the specified grease at the grease fitting on the slip yoke until grease purges from the dust seal.

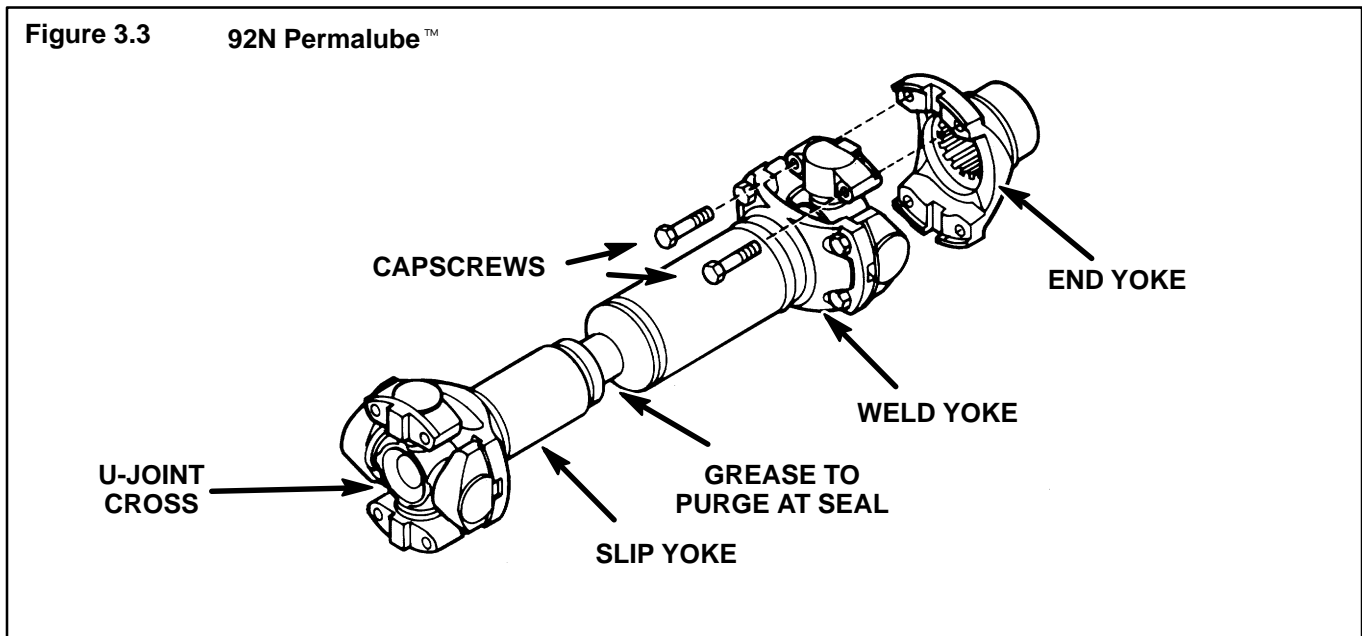

**Greasing Intervals and Specifications for  
Standard/Conventional Drivelines**

Component	Application	Greasing Interval	Grease	Meritor Specification	NLGI Grade	Grease Description	Outside Temperature
Universal Joint, Slip Yoke and Splines	Line Haul	50,000 miles (80,000 km)	Universal Joint Grease	O-634-B	2	Lithium 12-Hydroxy Stearate with Molybdenum Disulfide	②
	Highway	16,000 miles (25,000 km)					
	City	6,500 miles (10,000 km)					
	Construction	①					

- ① The greasing interval depends on the individual operating conditions, speed and loads. To determine the interval, inspect for the presence of grease at all positions until an interval can be determined. Grease the assembly as necessary.
- ② Refer to the grease manufacturer's specifications for the temperature service limits.

**Approved Lubricants**

Lubricant	Recommendation
Universal Joint Grease	Must meet Meritor Specification O-634-B (NLGI Grade No. 2, Lithium 12-Hydroxy Stearate with Molybdenum Disulfide) Amalie All purpose Grease with Moly-L1-2M Exxon 5160 Shell Super Duty Special FF Marathon Maralube Molycode 529 Phillips Petroleum Philube MW-EP2 Grease

# Section 4

## Front Driving Axle



### General Information

Drive axles generate small metal wear particles at a fairly steady rate, especially during the break-in period. If these fine, but hard particles are allowed to circulate in the lubricant, along with external moisture and dirt, internal components will wear at a much faster rate than normal.

### Magnets and Magnetic Drain Plugs

Meritor front driving axles are equipped with magnetic drain plugs that have a minimum pick-up capacity of 1.5 pounds (0.7 kilograms) of low carbon steel.

The **magnetic drain plug** can be reused if, after cleaning, the plug has a minimum pick-up capacity of 1.5 pounds (0.7 kilograms) of low carbon steel.

**NOTE:** Meritor recommends replacing the magnetic drain plug each time the oil is changed. Use the correct part. Pipe plugs will leak if used as a drain plug.

### Breather

#### **CAUTION**

*Cover the breather when steam cleaning the housing to prevent water from entering the housing and contaminating the oil.*

Baffle-type breathers help keep Meritor axles free from external moisture and dirt, which can cause premature oil and component failure.

### Seals

#### **CAUTION**

*Always use the correct tools and procedures when replacing seals to prevent incorrect installation and leaking seals.*

Seals keep **lubricant in and dirt out** of a component. When they are worn or damaged, seals leak and produce low lubricant levels which may damage components.

Durable triple lip seals, standard in Meritor axles, protect the quality and levels of the lubricant and provide superior performance.

### Temperature Indicators

#### **CAUTION**

*Meritor axles can operate above 190° F (88° C) without damage. However, if the oil temperature reaches 250° F (121° C), stop the vehicle immediately and check for the cause of overheating.*

Many Meritor axles have a tapped hole in the housing for the installation of a lubricant temperature indicator that will help reduce the failure of axle parts from overheated oil.

### Oil Level



#### Check and Adjust Oil

#### **WARNING**

*To prevent serious eye injury, always wear safe eye protection when you perform vehicle maintenance or service.*

1. Make sure the vehicle is parked on a level surface.
2. Remove the fill plug from the axle.
3. The oil level must be even with the bottom of the fill plug hole.
  - If oil flows from the hole when the plug is loosened, the oil level is high. Let the oil drain to the correct level.
  - If the oil level is below the bottom of the fill plug hole, add the specified oil.
4. Install and tighten the fill plug to 35-50 lb-ft (48-67 N•m). 

## Drain and Replace Oil

1. Make sure the vehicle is parked on a level surface. Put a large container under the axle.
2. Remove the drain plug from the bottom of the axle. Drain and discard the oil properly.
3. Clean, install and tighten the drain plug to 35-50 lb-ft (48-67 N•m). 
4. Remove the fill plug from the axle.
5. Fill the axle to the bottom of the fill plug hole with the specified oil. Allow enough time for oil to circulate through the axle assembly.
6. Install and tighten the fill plug to 35-50 lb-ft (48-67 N•m). 

## Wheel Bearings and Wheel Ends

See Section 12, "Wheel Bearings and Wheel Ends," for lubrication information on oil- and grease-lubricated wheel bearings and wheel ends.

## Drive Axle Shaft Universal Joint

1. Permanently lubricated (Permalube) joints do not have a grease fitting provided. Periodic greasing is not required for these parts. For serviceable universal joints (with grease fittings) follow steps 2 and 3.
2. Clean all grease fittings prior to lubrication.
3. Apply the specified grease at the grease fitting on the universal joint. Apply grease until new grease purges from all the seals.
4. If new grease does not purge at every seal, move the driveline while applying grease at the fittings until new grease purges at every seal. If new grease still does not purge, disassemble the universal joint. Inspect the grease and the components. Service as necessary.

## Axle Shaft Spline and Thrust Washer

1. Apply grease at hub flange fitting.
2. Check that grease purges at the thrust washer and spindle seal located inside of the knuckle.

## Cross Tube End Assembly

1. Check the cross tube for looseness of more than .060 inch (1.52mm). **Figure 4.1**. If loose, service as necessary .
2. Apply the specified grease at the grease fitting on the cross tube. Apply grease until new grease purges from all the seals.
3. If new grease does not purge at the seals, move the cross tube while applying grease at the fittings until new grease purges from all the seals. If new grease still does not purge, disassemble the cross tube. Inspect the grease and the components. Service as necessary.

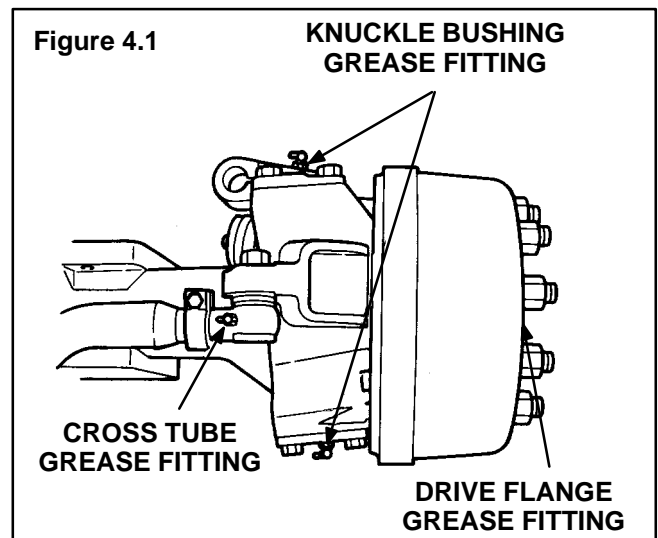

## Knuckle Bushing

1. Check the knuckle for looseness. The correct end play is 0.005 - 0.015 inch (.127-.381mm). **Figure 4.1**. If loose, service as necessary.
2. Clean all grease fittings prior to lubrication.
3. Apply the specified grease at the grease fitting on the knuckle. Apply grease until new grease purges from all the seals. Grease the lower pin cap with the vehicle weight on the wheel end to ensure that the thrust bearing is completely greased.
4. If new grease does not purge at the seals, move the knuckle while applying grease at the fittings until new grease purges at the seals. If new grease still does not purge, disassemble the knuckle. Inspect the grease and the components. Service as necessary.

# Section 4

## Front Driving Axle



### Front Driving Axle Oil Change Intervals and Specifications ①

Operation	On-Highway	Off-Highway
Initial Oil Change	3,000 miles (4,800 km)	3,000 miles (4,800 km)
Check Oil Level	3,000 miles (4,800 km) or 200 operating hours (whichever comes first)	3,000 miles (4,800 km)
Petroleum Oil Change	30,000 miles (48,000 km) or 2,000 operating hours (whichever comes first)	30,000 miles (48,000 km) or 2,000 operating hours (whichever comes first)
Synthetic Oil Change	-----	-----

Meritor Specifications	Military Specification Approval	Oil Description	Outside Temperature			
			F°		C°	
			Min.	Max.	Min.	Max.
O-76A, Gear Oil	MIL-L-2105D or MIL-PRF-2105-E	GL-5, SAE 85W/140	10	None	-12	None
O-76D, Gear Oil		GL-5, SAE 80W/90	-15	None	-26	None
O-76E, Gear Oil		GL-5, SAE 75W/90	-40	None	-40	None
O-76J, Gear Oil		GL-5, SAE 75W	-40	35	-40	2
O-76L, Gear Oil		GL-5, SAE 75W/140	-40	None	-40	None

① If the front drive axle is the only axle on the vehicle, change the oil every 15,000 miles (24,000 km) or 1,000 hours of operation, whichever comes first.

### Front Driving Axle Greasing Intervals and Specifications

Component	Greasing Intervals	Grease	Meritor Specification	NLGI Grade	Grease Description	Outside Temperature
Cross Tube End Assemblies, Knuckle Bushings and Drive Flange	3,000 miles (4,800 km) or 200 hours of operation, whichever comes first.	Multi-Purpose Grease	O-617-A or O-617-B	1 or 2	Lithium 12-Hydroxy Stearate or Lithium Complex	Refer to the grease manufacturer's specifications for the temperature service limits.
U-Joints		U-Joint Grease	O-634-B	2	Lithium 12-Hydroxy Stearate with Molybdenum Disulfide	



## Front Driving Axle Oil Capacities

Axle Model	Oil Capacity	
	Pints	Liters
FDS-75	13.0	6.2
FDS-78	13.0	6.2
FDS-85	13.0	6.2
FDS-90	13.0	6.2
FDS-93	13.0	6.2
FDS-750	13.9	6.5
FDS-1600	21.0	9.9
FDS-1800	28.0	13.2
FDS-1805	28.0	13.2
FDS-1807	28.0	13.2
FDS-1808	28.0	13.2
FDS-2100	28.0	13.2
FDS-2101	28.0	13.2
FDS-2102	43.0	20.3

Axle Model	Oil Capacity	
	Pints	Liters
FDS-2107	43.0	20.3
FDS-2110	43.0	20.3
FDS-2111	43.0	20.3
FDS-2117	43.0	20.3
RF-7-106 ①	14.0	6.6
RF-9-106 ①	14.0	6.6
RF-12-125 ①	15.3	7.2
RF-16-145 ①	36.4	17.2
RF-21-155 ①	27.9	13.2
RF-21-156 ①	27.9	13.2
RF-21-160 ①	43.7	20.7
RF-21-355 ①	28.0	13.2
RF-23-180 ①	39.3	18.6

- ① Oil capacities are for standard track axles that have been measured at various common drive pinion angles. The quantities listed include enough oil for both wheel ends. These oil capacities will change if the track or the drive pinion angle is different.

# Section 5

## Front Non-Driving Axle



### King Pins

#### Conventional Front Axles

**NOTE:** This procedure applies to 901, 903, 910, 935 and 970 front conventional axles. See the identification tag on the front of the axle beam.

On conventional front axles, the grease fittings are on the side of the knuckle.

#### **WARNING**

*To prevent serious eye injury, always wear safe eye protection when you perform vehicle maintenance or service.*

*Support the vehicle with safety stands. Do not work under a vehicle supported only by jacks. Jacks can slip or fall over and cause serious personal injury.*

1. Lift the vehicle so that the tires are off the ground. The tires should always be off the ground when the king pins are lubricated. Support the vehicle with safety stands. Put blocks in front and in back of the rear wheels to keep the vehicle from moving.
2. Clean all grease fittings prior to lubrication.
3. Lubricate the king pins through the top and the bottom grease fittings on the side of the knuckle. **Figure 5.1.**
4. Apply lubricant to the top fitting until new lubricant purges from between the upper shim pack and thrust bearing seal.
5. Lower the vehicle so that the wheels touch the ground.
6. Apply lubricant to the bottom fitting until new lubricant purges and fills the thrust bearing.

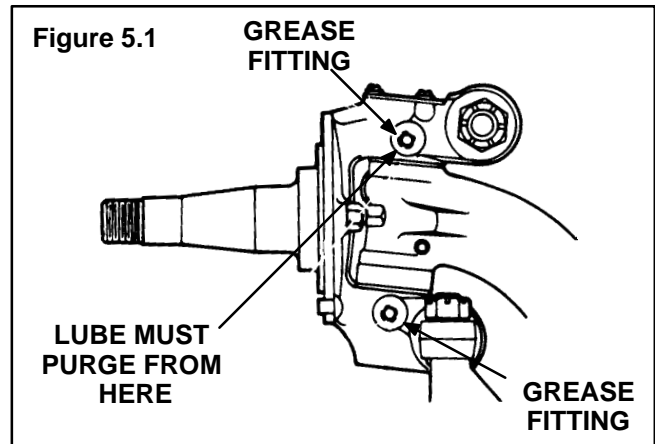

#### Sealed and Easy Steer™ Front Axles

**NOTE:** This procedure applies to 911, 921, 931, 932, 933, 934, 941, 942, 943, 944, 951, 952, 961, 963, 971 and 975 Series sealed front axles. See the identification tag on the front of the axle beam.

On sealed and Easy Steer™ front axles, the grease fittings are on the top and bottom king pin caps of the knuckle.

1. Make sure the tires touch the ground. Do not elevate the vehicle.
2. Clean all grease fittings prior to lubrication.
3. Lubricate the king pins through the grease fittings on the top and bottom of the knuckle. **Figure 5.2.**
4. Apply lubricant until new lubricant purges from the thrust bearing seal and the upper shim pack.

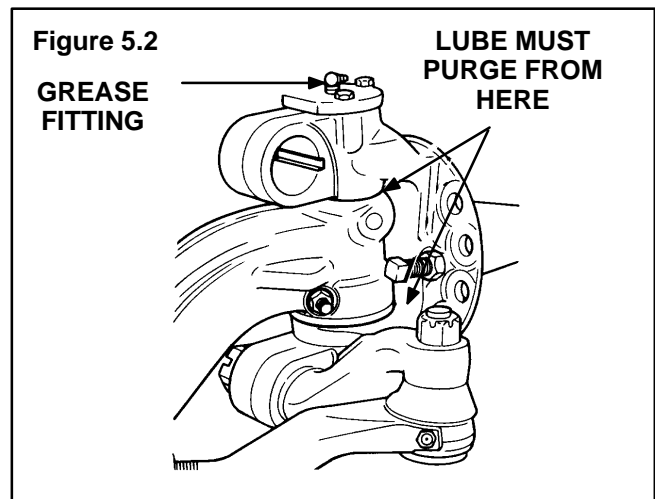

## Easy Steer Plus™ Front Axles

**NOTE:** Removal of the long-life bearings, seals and lubricant from the hub assembly will void the warranty.

Meritor's Easy Steer Plus™ front axle features a permanently sealed and lubricated truck hub unit designed to help reduce wheel-end maintenance. For Easy Steer Plus™ service procedures, refer to Maintenance Manual No. 2A, *Easy Steer Plus™ Front Axle*.

### **CAUTION**

*A unitized hub is permanently sealed and lubricated as an assembly. Do not attempt to remove the hub bearings, seals and lubricant. You can not service or reinstall these components into a unitized hub assembly. Damage to components can result.*

### **WARNING**

*To prevent serious eye injury, always wear safe eye protection when you perform vehicle maintenance or service.*

**NOTE:** On Easy Steer Plus™ front axles, the grease fittings are located on the top and bottom king pin caps.

1. Be certain that the tires touch the ground. Do not raise the vehicle.
2. Clean all grease fittings prior to lubrication.
3. Lubricate the king pins through the grease fittings on the top and bottom of the knuckle. **Figure 5.3.**
4. Force lubricant into upper and lower king pin grease fitting caps until new lubricant flows from between the following two areas:
  - a. Upper axle beam end and the knuckle. **Figure 5.3.**
  - b. Lower axle beam end and the knuckle. **Figure 5.3.**

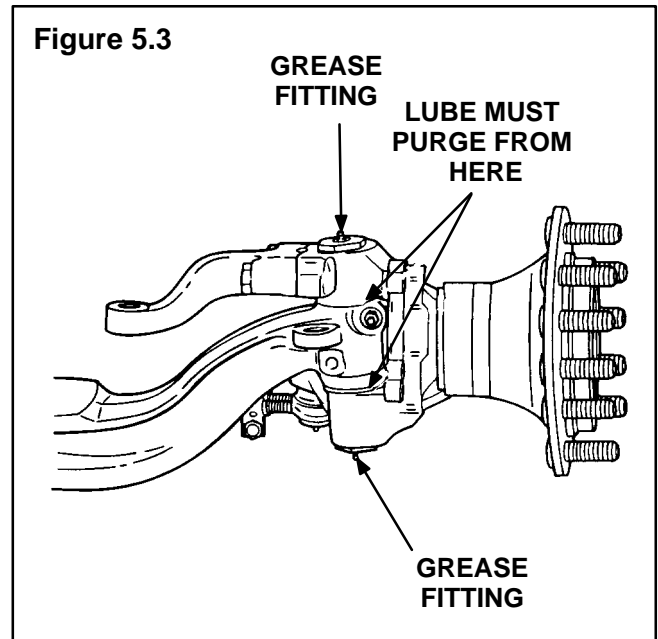

# Section 5

## Front Non-Driving Axle



### Conventional Front Non-Driving Axle Greasing Intervals and Specifications

Applies to all FF and FD Series axle models used in linehaul and city delivery vocations and including FD-931, FD-933 and FD-961 applications.

Component	Greasing Intervals	Grease	Meritor Specification	NLGI Grade	Grease Description	Outside Temperature
King Pins and Bushings	100,000 miles (160,000 km) or once a year, whichever comes first.	Multi-Purpose Grease	O-617-A	1	Lithium 12-Hydroxy Stearate or Lithium Complex	Refer to the grease manufacturer's specifications for the temperature service limits.
Ball Studs on Steering Arm, Tie Rod Arm Ends and Drag Link ①			O-617-B	2		

① Applies to ball studs on conventional and Easy Steer™ front axles. For sealed axles, inspect the boot on the ball stud every 96,000 miles (154,000 km) for wear and damage. Service as necessary.

### Conventional Front Non-Driving Axle Greasing Intervals and Specifications

Applies to all FF Series axle model used in other vocations (not linehaul) and including all FC-901, FC-903, FC-921, FC-941, FD-901, FE-970, FG-931, FG-933, FG-941, FG-943, FL-931, FL-941, FL-951, FU-910 and FU-935 applications.

Component	Greasing Intervals	Grease	Meritor Specification	NLGI Grade	Grease Description	Outside Temperature
King Pins and Bushings	50,000 miles (80,000 km) or once a year, whichever comes first.	Multi-Purpose Grease	O-617-A	1	Lithium 12-Hydroxy Stearate or Lithium Complex	Refer to the grease manufacturer's specifications for the temperature service limits.
Ball Studs on Steering Arm, Tie Rod Arm Ends and Drag Link ①			O-617-B	2		

① Applies to ball studs on conventional and Easy Steer™ axles. For sealed axles, inspect the boot on the ball stud every 96,000 miles (154,000 km) for wear and damage. Service as necessary.

**Easy Steer Plus™ Front Non-Driving Axle Greasing Intervals and Specifications**

**Applies to FF 981, FF 982, FF 983, FF 984 and FF 985 front non-driving steering axles in all vocations.**

Component	Greasing Intervals	Grease	Meritor Specification	NLGI Grade	Grease Description
King Pins and Bushings	100,000 miles (160,000 km) or once a year, whichever comes first.	Multi-Purpose Grease	O-617-A	1	Lithium 12-Hydroxy Stearate or Lithium Complex
Ball Studs on Steering Arm, Tie Rod Arm Ends and Drag Link ①			O-617-B	2	
Truck Hub Unit	No Lube to Hub	Unit sealed for life of component		NONE	DO NOT LUBRICATE

① Applies to ball studs on conventional and Easy Steer™ axles. For sealed axles, inspect the boot on the ball stud every 96,000 miles (154,000 km) for wear and damage. Service as necessary.

# Section 5 Front Non-Driving Axle



## Ball Studs on the Steering Arm, Tie Rod Arm Ends and Drag Link

### Conventional Front Axles Easy Steer™ Front Axles Easy Steer™ Plus Front Axles

1. Be certain that the tires touch the ground. Do not raise the vehicle.
2. Clean oil grease fittings prior to lubrication.
3. Apply lubricant at each grease fitting until new lubricant flows from the boot.  
**Figures 5.4 and 5.5.**

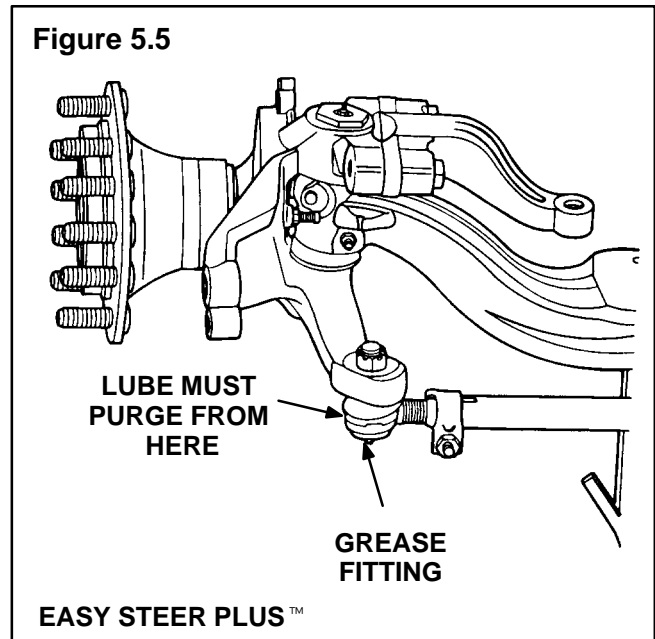
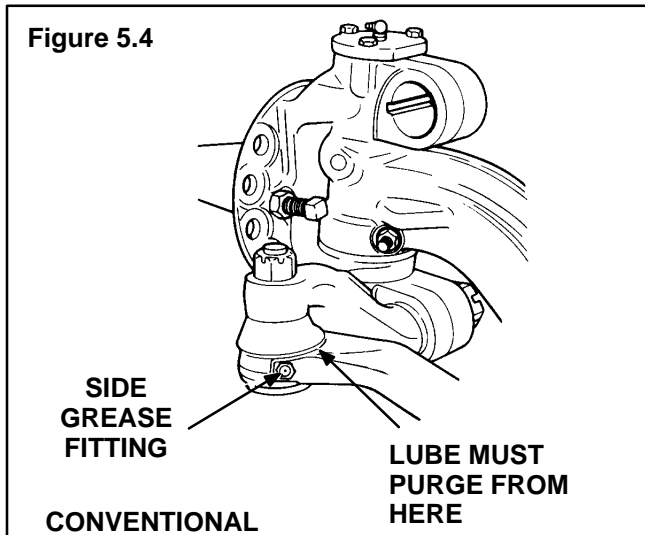

## Wheel Bearings and Wheel Ends

### Conventional Front Axles Easy Steer™ Front Axles Easy Steer Plus™ Front Axles

Refer to Section 12, "Wheel Bearings and Wheel Ends," for oil and grease lubrication information.

## Q Plus™, Cast Plus™, Q Series, P Series and T Series Cam Brakes

Meritor cam brakes are air-actuated, cam-operated, two-shoe brakes with each shoe mounted on a separate anchor pin. The brakes are available with automatic or manual slack adjusters and can be assembled with spring brakes.

### **WARNING**

*If grease flows from the seal near the cam head, replace the seal. Remove any grease or oil from the cam head, rollers and linings. Always replace contaminated linings. Grease on the linings can increase stopping distances. Serious personal injury and damage to components can result.*

### Cam Brake Grease Specifications

Components	Meritor Specification	NLGI Grade	Grease Description	Outside Temperature
Retainer Clips Anchor Pins Roller (Journals Only) Camshaft Bushings  When the brake is disassembled, or when necessary, lubricate the anchor pins and rollers where they touch the brake shoes.  Do not allow grease to come in contact with the part of the cam roller that touches the cam head. Refer to the <b>WARNING</b> , above.	O-616-A	1	Clay Base	Down to -40°F (-40°C)
	O-617-A or O-617-B	1  2	Lithium 12-Hydroxy Stearate or Lithium Complex	Refer to the grease manufacturer's specifications for the temperature service limits.
	O-645	2	Synthetic Oil, Clay Base	Down to -65°F (-54°C)
	O-692	1 and 2	Lithium Base	Down to -40°F (-40°C)
Camshaft Splines	Any of Above	See Above	See Above	See Above
	O-637*	1 1/2	Calcium Base	Refer to the grease manufacturer's specifications for the temperature service limits.
	O-641	---	Anti-Seize	

\*Do not mix 0-637 calcium-base, corrosion-control grease with other greases.

### Air Disc Brake (1540, 1560, 1760) Grease Specifications

Component	Meritor Specification	NLGI Grade	Grease Description	Outside Temperature
Caliper ①	O-616-A	1	Clay Base	Down to -40°F (-40°C)
	O-645	2	Synthetic Oil, Clay Base	Down to -65°F (-54°C)
Slide Pin Retainers	O-637*	1 -1/2	Calcium Base	Refer to the grease manufacturer's specifications for the temperature service limits.
	O-641	---	Anti-Seize	
Powershaft Splines	Any of Above	See Above	See Above	See Above

① The grease used inside the caliper must be non-melting and also allow proper brake function at the cold temperatures listed.

\*Do not mix 0-637 calcium-base, corrosion-control grease with other greases.

# Section 6 On-Highway Brakes



## Wedge Brake Grease Specifications

Component	Meritor Specification	NLGI Grade	Grease Description	Outside Temperature
All Actuating Components, All Areas Where Shoes Contact Spider, Anchor Plungers, Adjusting Bolts or Retainer Hardware	O-616-A	1	Clay Base	Down to -40°F (-40°C)
	O-645	2	Synthetic Oil, Clay Base	Down to -65°F (-54°C)

## Conventional Automatic Slack Adjuster Grease Specifications

Component	Meritor Specification	NLGI Grade	Grease Description	Outside Temperature
Automatic Slack Adjuster	O-616-A	1	Clay Base	Down to -40°F (-40°C)
	O-692	1 and 2	Lithium Base	Down to -40°F (-40°C)
	O-645	2	Synthetic Oil, Clay Base	Down to -65°F (-54°C)
Clevis Pins	Any of Above	See Above	See Above	See Above
	O-637*	1 - 1/2	Calcium Base	Refer to the grease manufacturer's specifications for the temperature service limits.
	O-641	---	Anti-Seize	

\*Do not mix O-637 calcium-base, corrosion-control grease with other greases.

## Manual Slack Adjuster Grease Specifications

Component	Meritor Specification	NLGI Grade	Grease Description	Outside Temperature
Manual Slack Adjuster	O-616-A	1	Clay Base	Down to -40°F (-40°C)
	O-617-A or O-617-B	1	Lithium 12-Hydroxy Stearate or Lithium Complex	Refer to the grease manufacturer's specifications for the temperature service limits.
		2		
	O-645	2	Synthetic Oil, Clay Base	Down to -65°F (-54°C)
O-692	1 and 2	Lithium Base	Down to -40°F (-40°C)	
Clevis Pins	Any of Above	See Above	See Above	See Above
	O-637*	1 - 1/2	Calcium Base	Refer to the grease manufacturer's specifications for the temperature service limits.
	O-641	---	Anti-Seize	

\*Do not mix O-637 calcium-base, corrosion-control grease with other greases.



### Q Plus™ LX500 Cam Brake Package with the Extended Lube Feature

#### Available for On-Highway Linehaul and All Other Applications

**NOTE:** You must continue to observe all other brake preventive maintenance schedules and procedures for Q Plus™ LX500 and MX500 cam brakes with factory-installed Meritor automatic slack adjusters. Refer to Maintenance Manual No. MM-96173, Q Plus™ LX500 Cam Brakes; and Maintenance Manual No. 4B, Automatic Slack Adjuster.

Meritor's new Q Plus™ LX500 Cam Brake package with the Extended Lube feature is available for on-highway linehaul and all other applications and includes:

- Q Plus™ LX500 cam brakes.
- Meritor factory-installed automatic slack adjusters.
- **Extended Lube Feature:** For on-highway linehaul applications, the Q Plus™ LX500 camshaft and slack adjusters do not require lubrication for **3 years or 500,000 miles (800,000 km), whichever comes first.** For all other applications, the lubrication interval is **one year, regardless of mileage.**

### Q Plus™ MX500 Extended Maintenance Package Option Available for On-Highway Linehaul Applications Only

Meritor's new Q Plus™ MX500 cam brake is available for on-highway linehaul applications only and includes:

- **Extended Maintenance Package:** Proprietary friction material on 5-inch wider shoes for front axles and 8-inch wider shoes for rear axles for more wearable volume than Q Plus™ LX500 brakes.
- **Extended Lube Feature:** The Q Plus™ MX500 camshaft and slack adjusters do not require lubrication and reline for **3 years or 500,000 miles (800,000 km), whichever comes first.**
- Meritor factory-installed automatic slack adjusters.

### Identifying Q Plus™ LX500 and MX500 Brakes

**NOTE:** Do not remove the identification tag from the camshaft bracket during the extended maintenance period.

You can identify Q Plus™ LX500 and MX500 cam brakes by checking the identification tags affixed to the brake.

1. A brake shoe tag identifies the brakes as Q Plus™ brakes.
2. An additional identification tag imprinted with **“SEE MERITOR MAINTENANCE MANUAL MM-96173 FOR LUBE INFO,”** which is affixed to the brake chamber bracket over the top of the plugged grease hole, identifies the brake as a Q Plus™ LX500 or MX500 brake.
3. Q Plus™ LX500 and MX500 brakes and automatic slack adjusters do not have grease fittings.

### Lubricating the Q Plus™ LX500 and MX500 Cam Brakes and Automatic Slack Adjusters After Specified Mileage or Time Intervals

1. Remove the identification tag from the chamber bracket housing.
2. Remove grease plugs from both the chamber bracket and the automatic slack adjuster.
3. Install grease fittings and lubricate the brake assembly through the grease fitting in the bracket with Meritor-approved synthetic grease, O-695, until new grease flows from the inboard seal.
4. Lubricate the automatic slack adjuster through the grease fitting until new grease flows out of the pull pawl or camshaft seal.
5. Replace the fittings with new grease plugs and cover the bracket plug with a new identification tag.

### Camshaft Bushings



#### **CAUTION**

*When grease flows from the seal near the cam head, replace the seal. Remove any grease from the cam head, rollers and linings. Grease on the linings can increase stopping distances.*

# Section 6

## On-Highway Brakes



### Q Plus™ LX500 and MX500 Greasing Service Intervals and Specifications

On-Highway Linehaul Applications	3 years or 50,000 miles (80,000 km), whichever comes first
All Other Applications	One year, regardless of mileage

Component	Meritor Specification	NLGI Grade	Grease Description	Outside Temperature
Camshaft Splines and Clevis Pins	O-695	2	Synthetic Polyurea	-40°F (-40°C)
Anchor Pins When the brake is disassembled, or when necessary, lubricate the anchor pins where they touch the brake shoes.	O-617-A or O-617-B	1  2	Lithium 12-Hydroxy Stearate or Lithium Complex	Refer to the grease manufacturer's specifications for the temperature service limits.
	O-645	2	Synthetic Oil, Clay Base	Down to -65°F (-54°C)
	O-692	1 and 2	Lithium Base	Down to -40°F (-40°C)
Shoe Rollers When the brake is disassembled, or when necessary, lubricate the rollers where they touch the brake shoes. DO NOT get grease on the part of the roller that touches the cam head.	O-617-A or O-617-B	1  2	Lithium 12-Hydroxy Stearate or Lithium Complex	Refer to the grease manufacturer's specifications for the temperature service limits
Automatic Slack Adjusters	O-695	2	Synthetic Polyurea	-40°F (-40°C)

### Approved Greases

Lubricant	Recommendation
O-616-A	Shell Darina Grease No. 1 Texaco Thermatex EP-1 Texaco Hytherm EP-1 Aralub 3837
O-617-A O-617-B	Multi-Purpose Lithium Chassis Grease
O-637*	Witco Chemical Corp. SA-824946
O-641	Never-Seez Anti-Seize

\* Do not mix O-637 calcium-base, corrosion-control grease with other greases.

Lubricant	Recommendation
O-645	Mobilgrease 28 (Military) Mobiltemp SHC 32 (Industrial) Aerospace Lubricants Inc. Tribolube 12-Grade1
O-692	Amoco Super Permalube #2 Citgo Premium Lithium EP-2 #2 Exxon Ronex MP-2 #2 Kendall L-427 Super Blu #2 Mobilith AW-1 #1 Sohio Factran EP-2 #2
O-695	EVO-LUBE TEK-615

### General Information

Drive axles generate small metal wear particles at a fairly steady rate, especially during the break-in period. If these fine, but hard particles are allowed to circulate in the lubricant, along with external moisture and dirt, internal components will wear at a much faster rate than normal.

**NOTE:** Refer to Section 1 for recommended oil drain conditions based on used axle oil analysis.

### Magnets and Magnetic Drain Plugs

Planetary axles are equipped with magnetic drain plugs that have a minimum pick-up capacity of 20 ounces (0.57 kilograms) of low carbon steel. The drain plug must be checked for metal particles at every oil change interval.

**NOTE:** Meritor recommends replacing the magnetic drain plug each time the oil is changed. Use the correct part. Pipe plugs will leak if used as a drain plug.

The **magnetic drain plug** can be reused if, after cleaning, the plug has a minimum pick-up capacity of 20 ounces (0.57 kilograms) of low carbon steel.

### Breather

#### **CAUTION**

**Cover the breather when steam cleaning the housing. If the breather is not covered, water can enter the housing and contaminate the oil.**

Breathers release pressure and vacuum condensation to minimize premature oil and component failure.

### Seals

#### **CAUTION**

**Always use the correct tools and procedures when replacing seals to prevent incorrect installation and leaking seals.**

Seals keep **lubricant in and dirt out** of a component. When they are worn or damaged, seals leak and produce damaging low lubricant levels.

### Temperature Indicators

#### **CAUTION**

**Meritor axles can operate above 190° F (88° C) without damage. However, if oil the temperature reaches 250° F (121° C), stop the vehicle immediately and check for the cause of overheating.**

### Oil Level

#### Check and Adjust Oil

For complete fill procedures for wet disc brakes, refer to Maintenance Manual No. 4L, *Wet Disc Brakes*.

#### **WARNING**

**To prevent serious eye injury, always wear safe eye protection when you perform vehicle maintenance or service.**

**NOTE:** Fill and drain plugs are located in the axle housing bowl and the wheel ends. Most axles have a common oil level. All steering axles and some rigid axles have separate oil levels in each wheel end and the axle housing bowl.

1. Make sure the vehicle is on a level surface.

**NOTE:** For axles with a common oil level that have drain and fill plugs only in the axle assembly, go to step 3.

2. Rotate the wheels so that the “oil level lines” on the wheel ends are parallel to the ground.

# Section 7

## Planetary Drive Axle



3. Clean the area around the fill/level plug. Remove the fill/level plug from the wheel ends and the axle housing bowl. **Figure 7.1.**

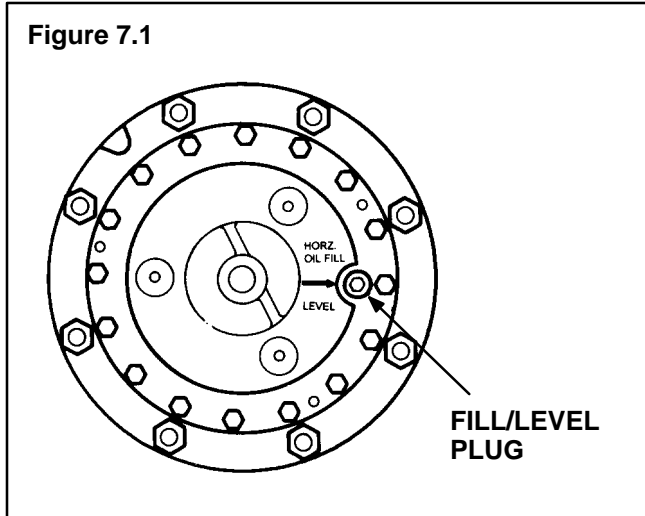

4. The oil level must be even with the bottom of the hole of the fill/level plug.

If oil flows from the hole when the plug is loosened, the oil level is high. Let the oil drain to the correct level.

If the oil level is below the bottom of the hole of the fill/level plug, add the specified oil. See the following:

- a. For axles with separate oil levels in the wheel ends and the axle housing bowl, fill each area to the bottom of the fill plug hole with the specified oil.

**NOTE:** Do not fill only through the axle housing bowl.

- b. For axles with a common oil level, fill the axle at each wheel end and the axle housing bowl to the bottom of the fill plug hole with the specified oil. Wait and allow the oil to flow through the axle. Check the oil level again and fill to the specified level if necessary.

5. Install and tighten the fill/level plugs to the correct torque specification.

## Drain and Replace Oil

**NOTE:** Fill and drain plugs are located in the axle housing bowl and the wheel ends. Most axles have a common oil level. All steering axles and some rigid axles have separate oil levels in each wheel end and the axle housing bowl.

### **WARNING**

**Support the vehicle with safety stands. Do not work under a vehicle only supported by jacks. Jacks can slip or fall over and cause serious personal injury.**

1. Make sure the vehicle is on a level surface. Put large containers under the axle and wheel ends.
2. Raise the vehicle so that the wheels are off the ground. Support the vehicle with safety stands.
3. Rotate the wheels so that the “fill/level” plugs in the wheel ends are toward the ground.
4. Remove the drain plugs from the wheel ends and axle housing bowl. Drain and discard the oil properly. Clean the plug.
5. Install and tighten the drain plug in the axle housing bowl and the wheel ends to 35-50 lb-ft (48-67 N•m).
6. Rotate the wheels so that the “oil level lines” on the wheel ends are parallel to the ground. Lower the vehicle.
7. Clean the area around the fill/level plug. Remove the fill/level plug from the wheel ends and the axle housing bowl.
8. Add the specified oil until the oil level is even with the bottom of the fill/level hole. See the following:
  - a. For axles with separate oil levels in the wheel ends and the axle housing bowl, fill each area to the bottom of the fill/level plug hole with the specified oil.

**NOTE:** Do not fill only through the axle housing bowl.

- b. For axles with a common oil level, fill the axle at each wheel end and the axle housing bowl to the bottom of the fill/level plug hole with the specified oil. Wait and allow the oil to flow through the axle. Check the oil level again and fill the specified level if necessary.
9. Install and tighten the fill/level plugs to the correct torque specification.

## Planetary Drive Axle Oil Change Intervals and Specifications

Operation	On-Highway <sup>①</sup>	Off-Highway <sup>①</sup>
Initial Oil Change	2,500 miles (4,000 km)	100 operating hours <sup>①</sup>
Check Oil Level	5,000 miles (8,000 km)	250 operating hours <sup>①</sup>
Petroleum Oil Change	25,000 miles (40,000 km) or once a year (whichever comes first)	1,500 operating hours or twice a year (whichever comes first) <sup>①</sup>
Synthetic Oil or Semi-Synthetic Oil Change	See Technical Publication TP-9303	3,000 operating hours or once a year (whichever comes first)

Meritor Specifications	Military Specification Approval	Oil Description	Outside Temperature			
			°F		°C	
			Min.	Max.	Min.	Max.
O-76A, Gear Oil	MIL-L-2105D or MIL-PRF-2105-E	GL-5, SAE 85W/140	10	None	-12	None
O-76D, Gear Oil		GL-5, SAE 80W/90	-15	None	-26	None
O-76E, Gear Oil		GL-5, SAE 75W/90	-40	None	-40	None
O-76L, Gear Oil		GL-5, SAE 75W/140	-40	None	-40	None
O-76M, Gear Oil		GL-5, SAE 75W/140	-40	None	-40	None
O-76N, Gear Oil		GL-5, SAE 75W/140	-40	None	-40	None

① The interval depends on the individual operating conditions, speeds and loads. Severe operating conditions may require more frequent intervals.

## Planetary Drive Axle Oil Capacities

Axle Model	Axle Housing Approximate Oil Capacity*		Wheel Ends Approximate Oil Capacity*	
	Pints	Liters	Pints	Liters
PR-53	33.0	15.6	3.0	1.4
PR-60	27.0	12.8	3.0	1.4
PR-100	22.0	10.4	3.5	1.6
PR-108	29.0	13.7	7.0	3.3
PR-111	27.0	12.8	4.6	2.2
PR-112	44.0	20.8	6.0	2.8
PR-145	32.0	15.1	5.0	2.4
PR-150	29.0	13.7	5.0	2.0
PR-151	30.0	14.2	8.0	3.8
PR-153	31.0	14.7	7.5	3.6
PR-200	40.0	18.9	6.0	2.8
PR-205	46.0	21.8	7.0	3.3

Axle Model	Axle Housing Approximate Oil Capacity*		Wheel Ends Approximate Oil Capacity*	
	Pints	Liters	Pints	Liters
PR-207	45.0	21.3	6.0	2.8
PR-208	43.0	20.3	8.0	3.8
PR-209	56.0	26.4	5.0	2.4
PR-251	42.0	19.9	12.0	5.7
PR-253	39.0	18.5	13.0	6.2
PR-256	44.0	20.8	18.0	8.5
PR-270	44.0	20.8	18.0	8.5
PR-350	28.0	13.2	14.0	16.6
PR-400	32.0	15.1	16.0	7.6
PR-500	56.0	26.5	28.0	13.2
PR-501	64.0	30.3	28.0	13.2
PR-502	62.0	29.3	31.0	14.7

\* Due to varied planetary drive axle specifications, these fill quantities are for reference only.

# Section 7

## Planetary Drive Axle



### Planetary Drive Axle Oil Capacities

Axle Model	Axle Housing Approximate Oil Capacity*		Wheel Ends Approximate Oil Capacity*	
	Pints	Liters	Pints	Liters
PR-700	64.0	30.3	30.0	14.19
PRC-184	32.0	15.1	4.0	1.8
PRC-264	16.0	7.5	4.0	1.8
PRC-755	32.0	15.1	10.0	4.7
PRC-864	30.0	14.1	6.0	2.8
PRC-867	48.0	22.7	10.0	4.7
PRC-1925	32.0	15.1	16.0	7.57
PRC-3795	28.0	13.2	14.0	6.62
PRC-3796	48.0	22.7	28.0	13.2
PRC-3805	58.0	27.4	22.0	10.4
PRC-4805	60.0	28.3	31.0	14.6
PRC-5324	80.0	37.8	24.0	11.3
PRC-5334	80.0	37.8	24.0	11.3
PRC-7314	72.0	34.0	24.0	11.3
PRLC-344	44.0	20.8	6.0	2.84
PRLC-614	29.0	13.7	7.0	3.31
PRLC-675	56.0	26.5	5.0	2.37
PRLC-823	44.0	20.8	18.0	8.51
PRLC-1756	39.0	18.5	13.0	6.15
PRLC-1757	39.0	18.5	13.0	6.15
PRLC-1925	72.0	34.0	12.0	5.6
PRLM-855	28.0	13.2	8.0	3.7
PRM-672	29.0	13.7	5.0	2.37
PRM-673	29.0	13.7	5.0	2.37
PRM-676	46.0	21.8	7.0	3.31
PRM-677	46.0	21.8	7.0	3.31
PRM-1314	44.0	20.8	18.0	8.51
PRM-1315	44.0	20.8	18.0	8.51
PRM-1615	44.0	20.8	18.0	8.51
PRM-1756	43.0	20.3	13.0	6.15
PRM-1757	43.0	20.3	13.0	6.15
PRTA-134	14.0	6.6	4.0	1.8
PRTC-203	19.0	8.9	6.0	2.8
PRS-16	27.0	12.8	3.0	1.42
PS-100	20.0	9.5	3.5	1.66
PS-150	22.0	10.4	5.0	2.37
PS-200	38.0	18.0	6.0	2.84
PS-260	44.0	20.8	8.0	3.25
PS-270	44.0	20.8	8.0	3.78

Axle Model	Axle Housing Approximate Oil Capacity*		Wheel Ends Approximate Oil Capacity*	
	Pints	Liters	Pints	Liters
PS-310	36.0	17.0	14.0	6.62
PS-500	58.0	27.4	29.0	13.72
PSC-204	29.0	13.7	6.0	2.8
PSC-593	28.0	13.0	4.0	1.89
PSC-594	28.0	13.2	4.0	1.89
PSC-1615	40.0	18.9	8.0	3.78
PSC-1617	40.0	18.9	8.0	3.78
PSC-1875	56.0	26.4	20.0	9.4
PSC-4564	58.0	27.4	29.0	13.72
PSM-826	42.0	19.9	6.0	2.8
PSM-1044	44.0	20.8	6.0	2.8
PSM-1045	44.0	20.8	6.0	2.8
PSM-1614	44.0	20.8	8.0	3.7
PSTM-824	28.0	13.2	6.0	2.8
EPRC-1356				
Forward	32.0	15.1	14.0	6.6
Middle	32.0	15.1	14.0	6.6
Rear	32.0	15.1	14.0	6.6
SPRC-1356				
85" Track	32.0	15.1	14.0	6.6
90" Track	33.5	15.9	14.0	6.6
100" Track	36.0	17.0	14.0	6.6
SPRC-1357				
Forward	36.0	17.0	14.0	6.6
Rear	36.0	17.0	14.0	6.6
SPRC-1357				
85" Track	32.0	15.1	14.0	6.6
90" Track	33.5	15.9	14.0	6.6
100" Track	36.0	17.0	14.0	6.6
SPRC-1735				
85" Track	32.0	15.1	15.0	7.1
90" Track	33.5	15.9	15.0	7.1
100" Track	36.0	17.0	15.0	7.1
SPRC-1736				
Forward	36.0	17.0	15.0	7.1
Rear	36.0	17.0	15.0	7.1
SPRC-1736				
85" Track	32.0	15.1	15.0	7.1
90" Track	33.5	15.9	15.0	7.1
100" Track	36.0	17.0	15.0	7.1
SPRC-1926	32.0	15.1	16.0	7.6
SPRC-4806	64.0-72.0	31.0-34.0	32.0	15.1

\* Due to varied planetary drive axle specifications, these fill quantities are for reference only.

### Additional Information

**NOTE:** For a complete list of full synthetic axle oil suppliers, refer to TP-9539, “Approved Rear Drive Axle Lubricants.” Also, refer to Section 1 for recommended oil drain conditions based on used-axle oil analyses.

Drive axles generate small metal wear particles at a fairly steady rate, especially during the break-in period. If these fine, but hard particles are allowed to circulate in the lubricant, along with external moisture and dirt, internal components will wear at a much faster rate than normal.

### Magnets and Magnetic Drain Plugs

Although Meritor axles are normally equipped with magnetic plugs having a minimum pick-up capacity of 1.5 pounds (0.7 kilograms) of low carbon steel, Meritor “**Advanced Lube Axles**” have stronger magnetic “cleansing” features. They are equipped with strong 5-pound (2.2 kilograms) pull magnets and high grade magnetic fill and drain plugs that collect damaging particles at the bottom of the axle housing.

- **Tandem Axles** have four magnets in each housing and high grade magnetic fill and drain plugs.
- **Single Axles** have six magnets in each housing and high grade magnetic drain and fill plugs.

The drain plug must be checked for metal particles every 100,000 miles (160,000 kilometers).

**NOTE:** Meritor recommends replacing the magnetic drain plug each time the oil is changed. Use the correct part. Pipe plugs will leak if used as a drain plug.

The **magnetic drain plug** can be reused if, after cleaning, the plug has a minimum pick-up capacity of 1.5 pounds (0.7 kilograms) of low carbon steel.

### Breather

#### **CAUTION**

***Cover the breather when steam cleaning the housing. If the breather is not covered, water enters the housing and contaminates the oil.***

Baffle-type breathers release pressure and vacuum condensation to minimize premature oil and component failure.

### Seals

#### **CAUTION**

***Always use the correct tools and procedures when replacing seals to prevent incorrect installation and leaking seals.***

Seals keep **lubricant in and dirt out** of a component. When they are worn or damaged, seals leak and produce damaging low lubricant levels.

Durable triple-lip pinion seals, standard in Meritor axles, protect the quality and levels of the lubricant and provide superior performance.

Meritor “**Advanced Lube Axles**” have triple-lip seals designed to work with current and future lubricants.

### Temperature Indicators

#### **CAUTION**

***Meritor axles can operate above 190° F (88° C) without damage. However, if oil the temperature reaches 250° F (121° C), stop the vehicle immediately and check for the cause of overheating.***

Many Meritor axles have a tapped hole in the housing for the installation of a temperature indicator. Monitoring the oil temperature will help reduce component failure caused by overheated oil. This indicator is particularly useful in thru-drive tandem axles when severe operating conditions and mismatched or unequally inflated tires cause unacceptably high lubricant temperatures.

# Section 8 Rear Drive Axle



## “Advanced Lube Axles”

- These axles require different drain intervals than other axles. Refer to the “Oil Change Intervals” and “Oil Specifications” tables in this section.
- The vehicle manufacturer may attach a tag to identify an “Advanced Lube Axle.” If attached, the tag specifies that the axle is filled with semi-synthetic or full-synthetic gear oil. The tag would be located at the axle fill hole or on the inside of the door.

## For Meritor R-170 Axles Equipped with Traction Equalizer®

Meritor’s R-170 axles with Traction Equalizer® normally operate with either standard petroleum, semi-synthetic or full-synthetic oils.

## When to Use “Limited Slip Friction Modifiers”

Occasionally the Traction Equalizer® will “slip” or “stick.” When this happens, you will hear intervals of shrill noises when the vehicle operates at low speed or when the vehicle makes sharp turns. You can correct this condition by adding “limited slip friction modifiers.”

**NOTE:** “Limited slip friction modifiers” usually deteriorate more quickly than extreme pressure (EP) additives. Shorten the lubricant change schedule if you add a friction modifier.

- **At the initial lubricant change interval for an R-170 equipped with Traction Equalizer®:** Replace the factory-installed lubricant with an approved lubricant and one of the additives specified in the table below.
- **After the initial change interval:** Change the lubricant and the additive at or before 50,000 miles (80,000 km).

## Specifications

For all GL-5 oils (petroleum oil or synthetic), add one of the following modifiers specified in the table below.

Manufacturer	Specification
DSL-178	Guardsmen Products
Equa-Torque #2411 and #2414	Sta-Lube Corporation
Lubrizol # 6178	Lubrizol Corporation

## Quantities for R-170 Axles With and Without Traction Equalizer®

WITH Traction Equalizer®	WITHOUT Traction Equalizer®
40 pints oil (18.9 liters) + 3 Pints additive (1.4 liters)	43 pints oil (20.3 liters)

## Wheel Bearings and Wheel-Ends

For grease lubrication information, refer to Section 12.

## Oil Level

### Fill Plug Locations

1. If the fill plug is only in the axle-housing bowl, use that fill plug. Do not use the temperature sending unit hole. **Figure 8.1.**
2. If the drive pin angle is seven degrees or less, use the fill plug in the differential carrier. **Figures 8.2, 8.7.**
3. If the drive pin angle is more than seven degrees, use the fill plug in the axle-housing bowl. **Figures 8.4 - 8.8.**



### Check and Adjust the Oil

#### **CAUTION**

*Check the oil level when the axle is at room temperature. When hot, the oil temperature may be 190° F (88° C) or more and can cause burns. Also, a correct level is not obtained when the axle is warm or hot.*

1. Park the vehicle on a level surface. The axle must be “cold” or near room temperature.
2. Clean the area around the fill plug. Remove the fill plug from the differential carrier or the axle-housing bowl (depending on the axle). **Figure 8.2 - 8.8.**
3. Check the oil level. The level must be even with the bottom of the fill plug hole. **Figure 8.1.**
4. Install the fill plug. Tighten the plug to 35-50 lb-ft (48-67 N•m). **T**

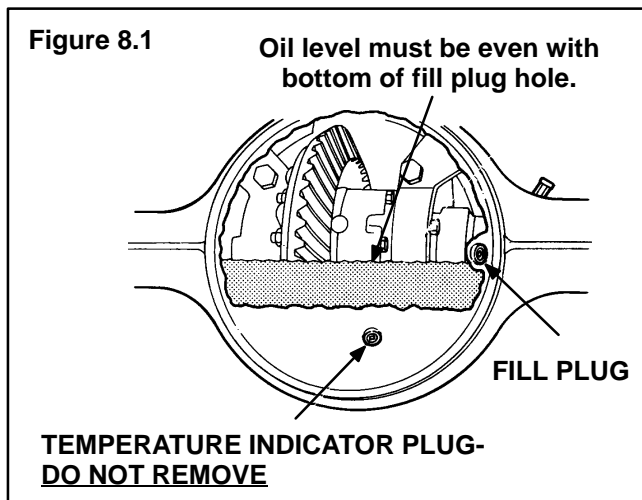

### Drain and Replace the Oil

**NOTE:** Drain the oil when it is warm.

1. Refer to “Fill Plug Locations” in this section.
2. Park the vehicle on a level surface. Put a large container under the axle.
3. Install the drain plug. Tighten the plug to 35-50 lb-ft (48-67 N•m). **T**

**NOTE:** Remove and replace the oil filters each time you drain the oil.

4. **If an oil pump is used:** Remove and replace the oil filters.

- For “Advanced Lube Axles”: Replace the oil filter every 100,000 miles (160,000 km).
5. Clean the area around the fill plug. Remove the fill plug from the differential carrier of the axle-housing bowl (depending on the axle).
  6. Add the specified oil until the oil is even with the bottom of the fill plug hole. Wait to allow the oil to flow through the axle.
  7. Check oil level again. If necessary, continue to add oil until it is even with the bottom of the fill plug hole.
  8. Install the fill plug. Tighten the plug to 35-50 lb-ft (48-67 N•m). **T**
  9. **If the inter-axle differential has a top fill plug hole:** Add an additional two pints (0.946 liters) of the same oil into the inter-axle differential housing.
- Refer to the section below for information on inter-axle differential assemblies with separate housings.

### Inter-Axle Assemblies with Separate Housings

Meritor’s SLHD, SQHD, STDD and SFDD forward-rear tandem axle carrier models include separate housings for inter-axle differential assemblies.

- The baffles and dams used in these housings hold a reservoir of oil that can also trap wear particles and debris. Always purge the oil from these reservoirs when you change axle oil.
- These carriers have separate drain and fill holes in either the inter-axle differential cover or housing.

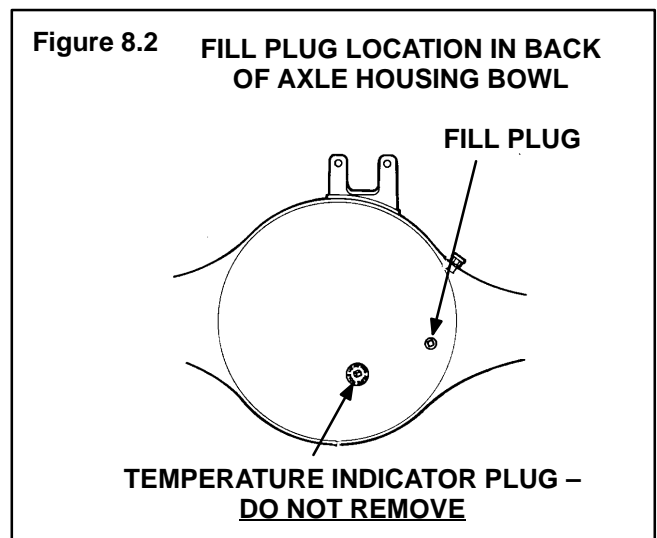

# Section 8 Rear Drive Axle

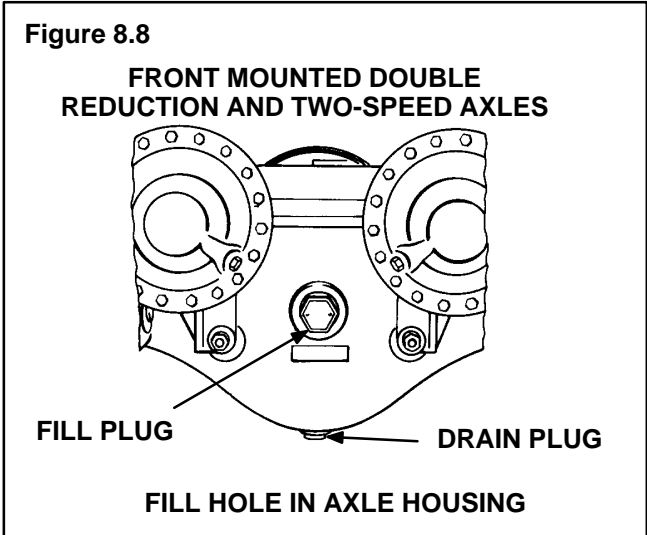
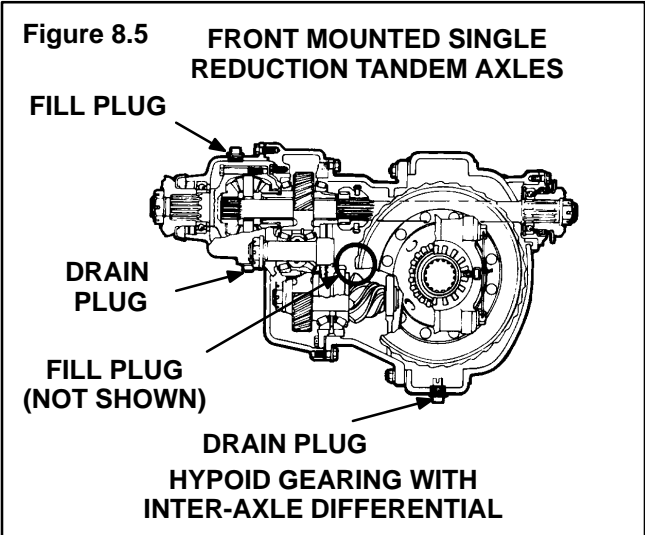
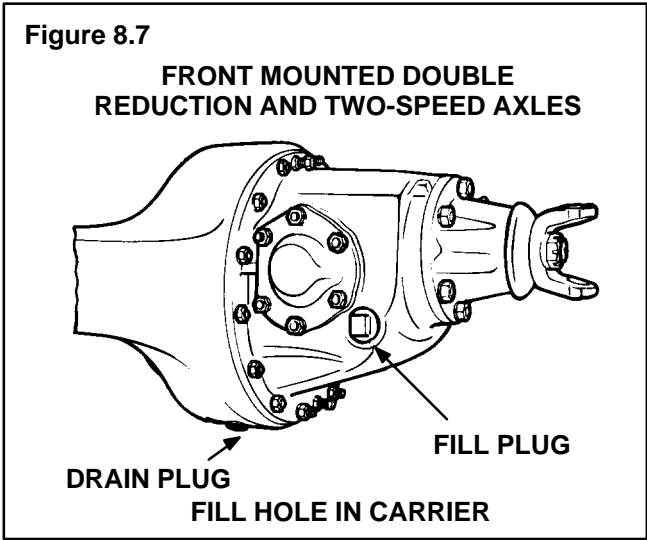
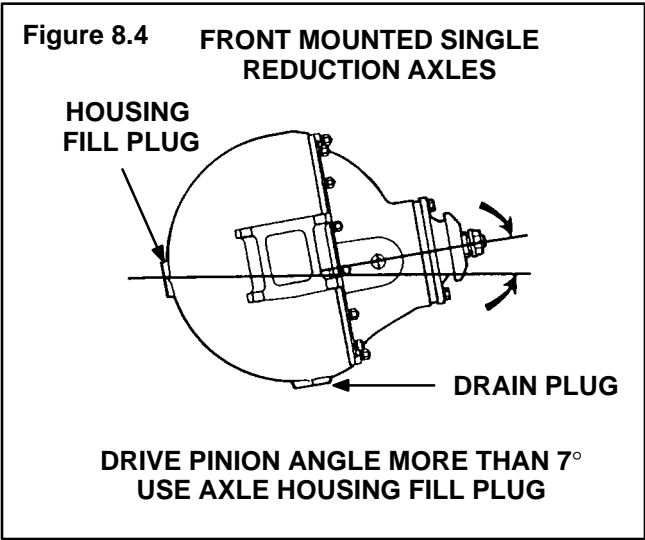
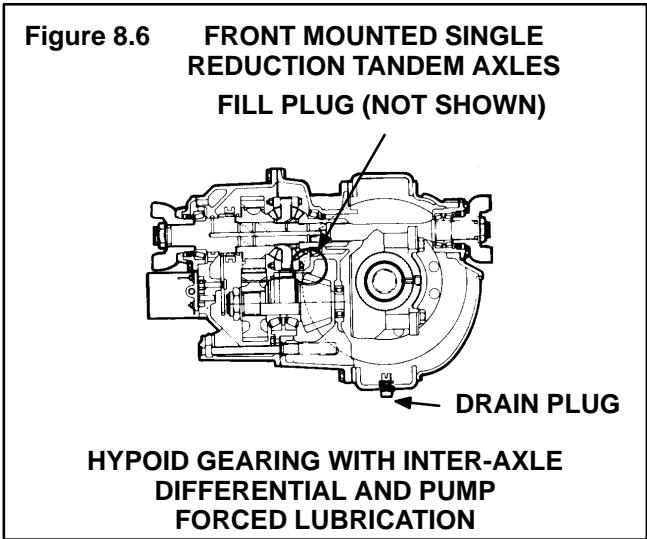
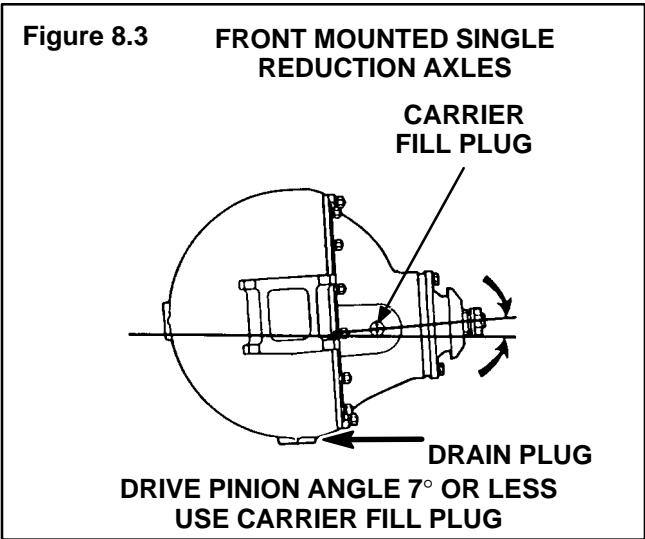

### Single Rear Drive Axle Oil Change Intervals and Specifications

Applies to single rear axles except “Advanced Lube” RS-13-120, RS-15-120, RS-23-180 and RS-23-380 series axles\*.

Operation	On-Highway	Off-Highway <sup>①</sup>
<b>Initial Oil Change</b>	1,000 miles (1,600 km)	1,000 miles (1,600 km)
<b>Check Oil Level</b>	3,000 miles (4,800 km), once a month or the fleet maintenance interval (whichever comes first)	3,000 miles (4,800 km)
<b>Petroleum Oil Change</b>	100,000 miles (160,000 km) or once a year (whichever comes first)	25,000 miles (40,000 km) or twice a year (whichever comes first)
<b>Synthetic Oil Change</b>	250,000 miles (400,000 km)	50,000 miles (80,000 km)

\* Consult Meritor or your Meritor representative for application information and updating.

Meritor Specifications	Military Specification Approval	Oil Description	Outside Temperature			
			°F		°C	
			Min.	Max.	Min.	Max.
O-76A, Gear Oil	MIL-L-2105D or MIL-PRF-2105-E	GL-5, SAE 85W/140	10	None	-12	None
O-76D, Gear Oil		GL-5, SAE 80W/90	-15	None	-26	None
O-76E, Gear Oil		GL-5, SAE 75W/90	-40	None	-40	None
O-76J, Gear Oil		GL-5, SAE 75W	-40	35	-40	2
O-76L, Gear Oil		GL-5, SAE 75W/140	-40	None	-40	None
O-76M, Full Synthetic Gear Oil		GL-5, SAE 75W/140	-40	None	-40	None
O-76N, Full Synthetic Gear Oil		GL-5, SAE 75W/90	-40	None	-40	None

① Includes heavy-duty on-highway and on/off-highway applications.

# Section 8

## Rear Drive Axle



### Single “Advanced Lube” Rear Drive Axle Oil Change Intervals and Specifications <sup>①</sup>

Applies to single rear axles manufactured after January 1, 1993, equipped with advanced material triple lip seals.

Operation	On-Highway	Off-Highway <sup>②</sup>
<b>Initial Oil Change</b>	Not Applicable	Not Applicable
<b>Check Oil Level</b>	3,000 miles (4,800 km), once a month or the fleet maintenance interval (whichever comes first)	3,000 miles (4,800 km) or 200 hours of operation (whichever comes first)
<b>Petroleum Oil Change<sup>③</sup></b>	100,000 miles (160,000 km)	40,000 miles (64,000 km)
<b>Synthetic Oil Change<sup>④</sup></b>	250,000 miles (400,000 km)	80,000 miles (128,000 km)

Meritor Specifications	Military Specification Approval	Oil Description	Outside Temperature			
			°F		°C	
			Min.	Max.	Min.	Max.
O-76A, Gear Oil	MIL-L-2105D or MIL-PRF-2105-E	GL-5, SAE 85W/140	10	None	-12	None
O-76D, Gear Oil		GL-5, SAE 80W/90	-15	None	-26	None
O-76E, Gear Oil		GL-5, SAE 75W/90	-40	None	-40	None
O-76J, Gear Oil		GL-5, SAE 75W	-40	35	-40	2
O-76L, Gear Oil		GL-5, SAE 75W/140	-40	None	-40	None
O-76M, Full Synthetic Gear Oil		GL-5, SAE 75W/140	-40	None	-40	None
O-76N, Full Synthetic Gear Oil		GL-5, SAE 75W/90	-40	None	-40	None

- ① If a No-Spin™ differential is installed, oil (petroleum or synthetic) must be changed at minimum of 40,000 miles (64,000 km) or a maximum interval of 50,000 miles (80,000 km).
- ② Applies to heavy-duty on-highway and on/off-highway applications. Does not apply to off-highway applications.
- ③ For extended-drain petroleum based oils, use “Synthetic Oil Change” interval.
- ④ Applies to approved semi-synthetic and full synthetic oils. For list of approved extended-drain oils, refer to Meritor’s Bulletin TP-9539, “Approved Rear Drive Axle Lubricants.” Call 800-535-5560 to obtain a copy of this publication.

## Tandem Rear Drive Axle Oil Change Intervals and Specifications <sup>①</sup>

Applies to all tandem rear axles except the “Advanced Lube” rear axles.

Operation	On-Highway	Off-Highway <sup>②</sup>
<b>Initial Oil Change</b>	3,000 miles (4,800 km)	1,000 miles (1,600 km)
<b>Check Oil Level</b>	3,000 miles (4,800 km), once a month or the fleet maintenance interval (whichever comes first)	3,000 miles (4,800 km)
<b>Petroleum Oil Change</b>	If annual mileage is less than 100,000 miles (160,000 km) change oil once a year. If annual mileage is more than 100,000 miles (160,000 km), change oil every 100,000 miles (160,000 km).	If annual mileage is less than 60,000 miles (96,000 km) change oil twice a year. <sup>③</sup> If annual mileage is more than 60,000 miles (96,000 km), change oil every 30,000 miles (48,000 km).
<b>Synthetic Oil Change<sup>④</sup></b>	250,000 miles (400,000 km)	50,000 miles (80,000 km)

Meritor Specifications	Military Specification Approval	Oil Description	Outside Temperature			
			°F		°C	
			Min.	Max.	Min.	Max.
O-76A, Gear Oil	MIL-L-2105D or MIL-PRF-2105-E	GL-5, SAE 85W/140	10	None	-12	None
O-76D, Gear Oil		GL-5, SAE 80W/90	-15	None	-26	None
O-76E, Gear Oil		GL-5, SAE 75W/90	-40	None	-40	None
O-76J, Gear Oil		GL-5, SAE 75W	-40	35	-40	2
O-76L, Gear Oil		GL-5, SAE 75W/140	-40	None	-40	None
O-76M, Full Synthetic Gear Oil		GL-5, SAE 75W/140	-40	None	-40	None
O-76N, Full Synthetic Gear Oil		GL-5, SAE 75W/90	-40	None	-40	None

- ① If oil pump and filter is used, change filter every 100,000 miles (160,000 km). Check oil level. Add correct oil as required.
- ② Includes heavy-duty on-highway and on/off-highway applications.
- ③ For continuous heavy-duty operation, check oil level every 1,000 miles (1,600 kilometers).
- ④ Applies to approved semi-synthetic and full synthetic oils. For list of approved extended-drain oils, refer to Meritor’s Bulletin TP-9539, “Approved Rear Drive Axle Lubricants.” Call 800-535-5560 to obtain a copy of this publication.

# Section 8 Rear Drive Axle



## Tandem “Advanced Lube” Rear Drive Axle without Oil Pump and Filter Oil Change Intervals and Specifications <sup>①</sup>

Applies to tandem rear axles manufactured after January 1, 1993, equipped with advanced material triple lip seals.

Operation	On-Highway	Off-Highway <sup>②</sup>
Check Oil Level	3,000 miles (4,800 km), once a month or the fleet maintenance interval (whichever comes first)	3,000 miles (4,800 km) or 200 hours of operation (whichever comes first) <sup>⑤</sup>
Petroleum Oil Change <sup>③</sup>	100,000 miles (160,000 km)	40,000 miles (64,000 km)
Synthetic Oil Change <sup>④</sup>	250,000 miles (400,000 km)	80,000 miles (128,000 km)

Meritor Specifications	Military Specification Approval	Oil Description	Outside Temperature			
			°F		°C	
			Min.	Max.	Min.	Max.
O-76A, Gear Oil	MIL-L-2105D or MIL-PRF-2105-E	GL-5, SAE 85W/140	10	None	-12	None
O-76D, Gear Oil		GL-5, SAE 80W/90	-15	None	-26	None
O-76E, Gear Oil		GL-5, SAE 75W/90	-40	None	-40	None
O-76J, Gear Oil		GL-5, SAE 75W	-40	35	-40	2
O-76L, Gear Oil		GL-5, SAE 75W/140	-40	None	-40	None
O-76M, Full Synthetic Gear Oil		GL-5, SAE 75W/140	-40	None	-40	None
O-76N, Full Synthetic Gear Oil		GL-5, SAE 75W/90	-40	None	-40	None

① If a No-Spin™ differential is installed, oil (petroleum or synthetic) must be changed at minimum interval of 40,000 miles (64,000 km) or a maximum interval of 50,000 miles (80,000 km).

② Also applies to heavy-duty on-highway applications. Does not apply to off-highway applications.

③ For extended-drain petroleum based oils, use the “Synthetic Oil Change” interval.

④ Applies to approved semi-synthetic and full synthetic oils. For list of approved extended-drain oils, refer to Meritor’s Bulletin TP-9539, “Approved Rear Drive Axle Lubricants.” Call 800-535-5560 to obtain a copy of this publication.

⑤ For continuous heavy-duty operation, check the oil level every 1,000 miles (1,600 km). Add the correct oil as required.

## Tandem “Advanced Lube” Rear Drive Axle with Oil Pump and Filter Oil Change Intervals and Specifications <sup>① ②</sup>

Applies to tandem rear axles manufactured after January 1, 1993, equipped with Membrane type breathers and advanced material triple lip seals:  
RT-34-145P, RT-40-145P, RT-44-145P, RT-46-160P, AND SQ-100P (Aluminum).

Operation	On-Highway	Off-Highway <sup>③</sup>
Check Oil Level	3,000 miles (4,800 km), once a month or the fleet maintenance interval (whichever comes first)	3,000 miles (4,800 km) or 200 hours of operation (whichever comes first) <sup>⑥</sup>
Petroleum Oil Change <sup>④</sup>	100,000 miles (160,000 km)	50,000 miles (80,000 km)
Synthetic Oil Change <sup>⑤</sup>	500,000 miles (800,000 km)	100,000 miles (160,000 km)

Meritor Specifications	Military Specification Approval	Oil Description	Outside Temperature			
			°F		°C	
			Min.	Max.	Min.	Max.
O-76A, Gear Oil	MIL-L-2105D or MIL-PRF-2105-E	GL-5, SAE 85W/140	10	None	-12	None
O-76D, Gear Oil		GL-5, SAE 80W/90	-15	None	-26	None
O-76E, Gear Oil		GL-5, SAE 75W/90	-40	None	-40	None
O-76J, Gear Oil		GL-5, SAE 75W	-40	35	-40	2
O-76L, Gear Oil		GL-5, SAE 75W/140	-40	None	-40	None
O-76M, Full Synthetic Gear Oil		GL-5, SAE 75W/140	-40	None	-40	None
O-76N, Full Synthetic Gear Oil		GL-5, SAE 75W/90	-40	None	-40	None

- ① Replace oil filter every 100,000 miles (160,000 km). Check oil level. Add specified oil as required.
- ② If No-Spin™ differential is installed, oil (petroleum or synthetic) must be changed at minimum interval of 40,000 miles (64,000 km) or a maximum interval of 50,000 miles (80,000 km).
- ③ Applies to heavy-duty on-highway applications and to on/off highway applications. Does not apply to off-highway applications.
- ④ For extended-drain petroleum based oils, use the “Synthetic Oil Change” interval.
- ⑤ Applies to approved semi-synthetic and full synthetic oils. For list of approved extended-drain oils, refer to Meritor’s Bulletin TP-9539, “Approved Rear Drive Axle Lubricants.” Call 800-535-5560 to obtain a copy of this publication.
- ⑥ For continuous heavy-duty operation, check oil level every 1,000 miles (1,600 km). Add the correct oil as required.

## Section 8 Rear Drive Axle



### Single Rear Drive Axle Oil Capacities

Axle Model	Oil Capacity ①	
	Pints	Liters
A-150	5.5	2.6
B-100	10.0	4.7
B-140	12.0	5.7
B-150	3.5	1.7
C-100	12.5	5.9
D-100	12.5	5.9
D-140	12.5	5.9
E-100	15.0	7.1
E-105	12.5	5.9
E-150	9.0	4.3
F-100	13.0	6.2
F-106	13.0	6.2
F-120	15.0	7.1
F-121	15.0	7.1
F-140	14.0	6.6
G-161	21.0	9.9
H-100	20.0	9.5
H-140	21.0	9.9
H-150	11.0	5.2
H-162	20.0	9.5
H-170	27.0	12.8
H-172	27.0	12.8
L-100	23.0	10.9
L-140	24.0	11.4
L-155	24.0	11.4
L-172	27.0	12.8
M-172	27.0	12.8
Q-100	31.0	14.7
Q-145	24.0	11.4
QT-140	24.0	11.4
R-100	30.0	14.2
R-140	28.0	13.3
R-155	28.0	13.3
R-160	28.0	13.3
R-163	34.0	16.1
R-170	43.0	20.3

Axle Model	Oil Capacity ①	
	Pints	Liters
R-270	55.0	26.0
RL-170	48.0	22.7
RS-13-120	18.4	8.7
RS-15-120	18.4	8.7
RS-15-210	14.3	6.8
RS-17-140	28.6	13.5
RS-17-145	33.6	15.9
RS-17-220	30.7	14.5
RS-19-145	33.2	15.7
RS-21-145	32.3	15.3
RS-21-230	38.9	18.4
RS-23-160	39.5	18.7
RS-23-161	37.2	17.6
RS-23-180	47.3	22.4
RS-23-186	47.3	22.4
RS-23-240	37.4	17.7
RS-23-380	63.6	30.1
RS-26-160	47.5	22.5
RS-26-180	46.6	22.0
RS-26-380	58.2	27.5
RS-30-180	46.6	22.0
RS-30-380	58.2	27.5
RS-38-380	53.1	25.1
S-170	43.0	20.3
U-140	24.0	11.4
U-170	43.0	20.3
U-270	55.0	26.0
W-170	43.0	20.3
W-270	55.0	26.0
59722	30.5	14.4
59723	30.5	14.4
59732	30.5	14.4
59733	30.5	14.4
59843	30.5	14.4
61142	42.0	19.8
61143	41.0	19.3

① Oil capacities are for standard track axles that have been measured at various common drive pinion angles. The quantities listed include enough oil for both wheel ends. These oil capacities will change if the track or the drive pinion angle is different.



### Tandem Rear Drive Axle Oil Capacities

Axle Model	Carrier	Oil Capacity ①	
		Pints	Liters
RT-34-140	Forward	26.0	12.3
	Rear	35.0	16.6
RT-34-145	Forward	29.6	14.0
	Rear	25.4	12.0
RT-34-145P	Forward	25.7	12.1
	Rear	23.4	11.1
RT-40-140	Forward	30.2	14.3
	Rear	22.8	10.8
RT-40-145	Forward	30.2	14.3
	Rear	25.8	12.2
RT-40-160	Forward	39.1	18.5
	Rear	39.4	16.3
RT-44-145	Forward	29.3	13.9
	Rear	25.1	11.9
RT-44-145P	Forward	25.2	12.0
	Rear	22.9	11.0
RT-46-160	Forward	39.1	18.5
	Rear	34.4	16.3
RT-46-160P	Forward	39.3	18.6
	Rear	34.7	16.4
RT-46-164	Forward	39.1	18.5
	Rear	39.4	16.3
RT-48-180 ②	Forward	61.1	28.9
	Rear	36.8	17.4
RT-48-380 ②	Forward	61.1	28.9
	Rear	63.6	30.1
RT-52-160	Forward	44.1	20.9
	Rear	41.2	19.5
RT-52-160P	Forward	44.1	20.9
	Rear	41.2	19.5
RT-52-180 ②	Forward	56.1	26.5
	Rear	36.1	17.1
RT-52-185	Forward	56.1	26.5
	Rear	36.1	17.1
RT-52-380 ②	Forward	56.1	26.5
	Rear	58.2	27.5

Axle Model	Carrier	Oil Capacity ①	
		Pints	Liters
RT-58-180 ②	Forward	56.1	26.5
	Rear	36.1	17.1
RT-58-185	Forward	56.1	26.5
	Rear	36.1	17.1
RT-58-380 ②	Forward	56.1	26.5
	Rear	58.2	27.5
RT-70-380 ②	Forward	54.4	25.7
	Rear	53.1	25.1
SFHD	Forward	17.0	8.0
	Rear	16.5	7.8
SL-100	Forward	39.6	18.7
	Rear	37.7	17.8
SLHD	Forward	32.5	15.3
	Rear	32.0	15.1
SQ-100	Forward	39.6	18.7
	Rear	37.7	17.8
SQ-100A	Forward	39.3	18.6
	Rear	37.6	17.8
SQHD	Forward	34.0	16.0
	Rear	31.0	14.7
SR-170	Forward	55.0	26.0
	Rear	43.0	20.3
SRHD	Forward	39.0	18.5
	Rear	36.0	17.0
SSHD	Forward	34.0	16.0
	Rear	28.0	13.2
ST-170	Forward	55.0	26.0
	Rear	43.0	20.3
STHD	Forward	34.0	16.0
	Rear	28.0	13.2
SU-170	Forward	55.0	26.0
	Rear	43.0	20.3
SUHD	Forward	34.0	16.0
	Rear	28.0	13.2
SW-170	Forward	55.0	26.0
	Rear	43.0	20.3

① Oil capacities are for standard track axles that have been measured at various common drive pinion angles. The quantities listed include enough oil for both wheel ends. These oil capacities will change if the track or the drive pinion angle is different.

② Forward carrier with oil pump system.

# Section 9 Trailer Axle



## TB Series Trailer Axles with Unitized Hub Assemblies

**NOTE:** Removal of the long-life bearings, seals and lubricant from the hub assembly will void the warranty.

Meritor's TB series trailer axle features a permanently sealed and lubricated unitized hub assembly designed to help reduce wheel-end maintenance.

The unitized hub is designed to remain in place on the axle for a minimum of five years or 500,000 miles (800,000 km).

For TB series unitized hub service procedures, refer to technical bulletin TP-96175: *Servicing Meritor's TB Series trailer Axles with Unitized Hub Assemblies*.

### **⚠ CAUTION**

*Meritor TB Series trailer axles with unitized hub assemblies use conventional brakes and automatic slack adjusters, as well as conventional tire-wheel assemblies. Service these components as you would under normal operation conditions to avoid damage to components.*

*A unitized hub is permanently sealed and lubricated as an assembly. Do not attempt to remove the hub bearings, seals and lubricant. You can not service or reinstall these components into a unitized hub assembly. Damage to components can result.*

## Comparing a Unitized Wheel-End to a Conventional Wheel-End

On a **unitized** wheel-end, you install the hub, seal, lubricant and bearings onto the axle spindle as an assembly. **Figure 9.1**. On a conventional wheel-end, you install the hub, seal, lubricant and bearings onto the axle spindle as separate components. **Figure 9.2**.

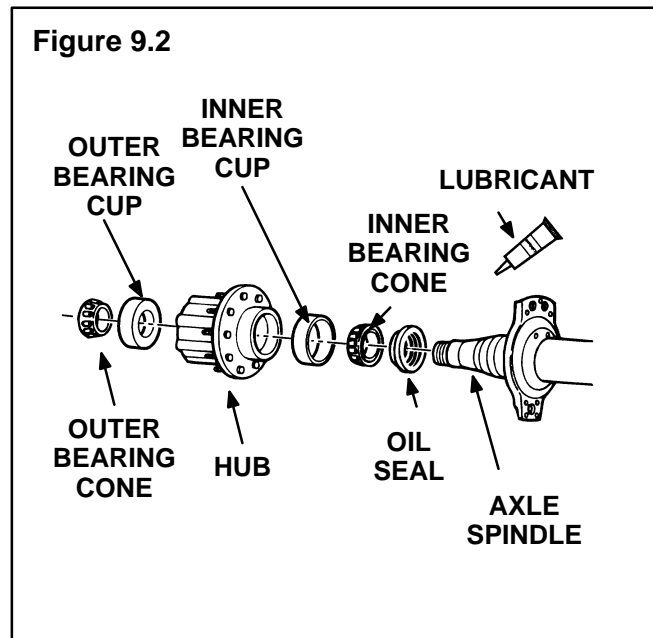
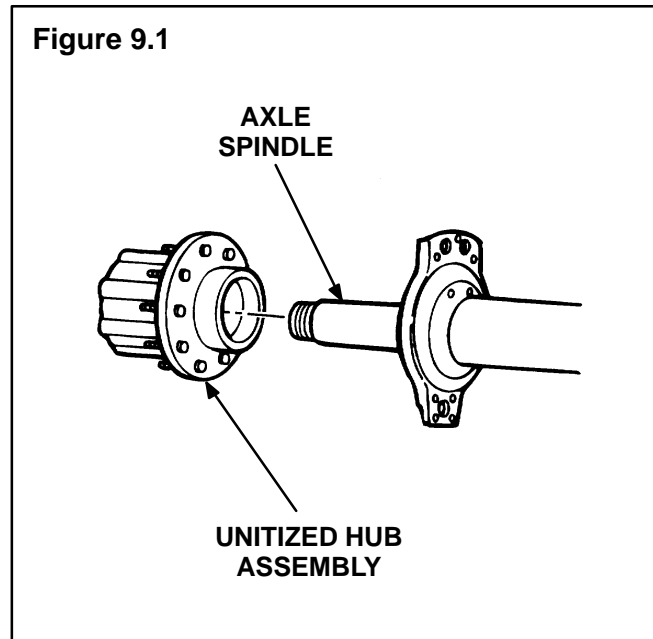

## Identifying a Trailer Axle with Unitized Wheel-Ends

- The model number designation for the TB series is prefixed with TB; for example, TB-4670 or TB-8670.
- The axle spindles are shorter with a single journal.
- The hubs contain non-serviceable bearings, seals and lubricant.
- The hubcaps screw onto the axle spindle and have no provisions for adding lubricant.
- The axle spindle retention hardware features a thicker inner nut and a bendable tab lockwasher.
- Warranty information is stamped on each unitized hub:

### **Important:**

Removal of long-life bearings, seals or lubricant from the Meritor TB series trailer axle hub will void the warranty. Refer to Technical Bulletin TP-96175 or call 800-535-5560 for information.



TP-9700

## Wheel Bearings and Wheel Ends

Refer to Section 12, "Wheel Bearings and Wheel Ends," for oil and grease lubrication information.

## Camshaft Bushings Conventional and TB Series

Apply the specified grease at the grease fitting on the spider. Apply grease until new grease purges from all the seals. **Figure 9.3.**

**Figure 9.3**

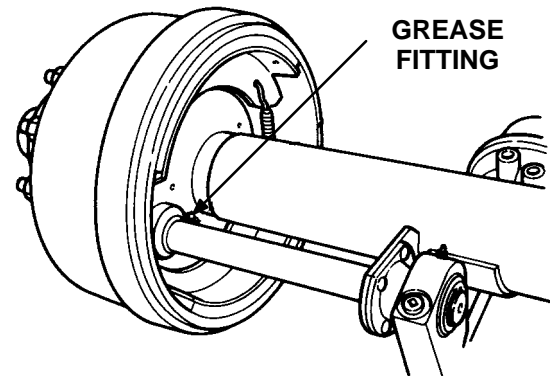

# Section 9 Trailer Axle



## Conventional and TB Series Camshaft Bushing Greasing Intervals and Specifications

Greasing Interval ①	Grease	Meritor Specification	NLGI Grade	Grease Description	Outside Temperature
Use the schedule below that gives the most frequent lubrication: <ul style="list-style-type: none"> <li>The lubrication schedule of the fleet.</li> <li>The lubrication schedule of the vehicle manufacturer.</li> <li>A minimum of four times during the life of the brake linings.</li> </ul>	Multi-Purpose Grease	O-617-A or O-617-B	1 or 2	Lithium 12-Hydroxy Stearate or Lithium Complex	Refer to the grease manufacturer's specifications for the temperature service limits.

① Applies to standard-duty on-highway service. Lubricate more frequently for heavy-duty applications. Determine intervals by inspecting lubricant every two weeks for a four month period. Look for hard, contaminated or missing grease. Choose an interval based on the inspection.

## Conventional Trailer Axle Wheel End Oil Change Intervals and Specifications

Check Oil Level	Oil Change ①	Meritor Specification	Military Specification Approval	Oil Description	Outside Temperature			
					°F		°C	
					Min.	Max.	Min.	Max.
1,000 miles (1,600 km)	<b>General Service:</b> Change oil if the wheel end is disturbed during wheel or hub removal or if the oil is contaminated. <b>Standard-Duty Service:</b> For 100,000 miles (160,000 km) or more a year, change the oil every 100,000 miles (160,000 km). For less than 100,000 miles (160,000 km) a year, change the oil once a year. <b>Heavy-Duty Service:</b> For 60,000 miles (96,000 km) or more a year, change oil every 30,000 miles (48,000 km). For less than 60,000 miles (96,000 km) a year, change the oil every 6 months.	O-76A, Gear Oil	MIL-L-2105D or MIL-PRF-2105-E	GL-5, SAE 85W/140	10	None	-12	None
		O-76D, Gear Oil		GL-5, SAE 80W/90	-15	None	-26	None
		O-76E, Gear Oil		GL-5, SAE 75W/90	-40	None	-40	None
		O-76J, Gear Oil		GL-5, SAE 75W	-40	35	-40	2
		O-76L, Gear Oil		GL-5, SAE 75W/140	-40	None	-40	None
		O-76M, Full Synthetic Gear Oil		GL-5, SAE 75W/140	-40	None	-40	None
		O-76N, Full Synthetic Gear Oil		GL-5, SAE 75W/90	-40	None	-40	None
		O-81 Full Synthetic Oil		SAE 50	-40	None	-40	None

① The recommended oil change interval is based on operating conditions, speeds and loads. Limited service applications may allow the recommended interval to be increased. Severe service applications may require the recommended interval to be reduced. For more information, contact Meritor's Customer Service Center at 800-535-5560.

**Conventional Trailer Axle Greasing Intervals and Specifications**

Greasing Interval ①	Grease	Meritor Specification	NLGI Grade	Grease Description	Outside Temperature
<p><b>General Service:</b> Grease the bearings if the wheel end is disturbed during wheel or hub removal or if the grease is contaminated.</p> <p><b>Standard-Duty Service:</b> For 100,000 miles (160,000 km) or more a year, grease the bearings every 100,000 miles (160,000 km). For less than 100,000 miles (160,000 km) a year, grease the bearings once a year.</p> <p><b>Heavy-Duty Service:</b> For 60,000 miles (96,000 km) or more a year, grease the bearings every 30,000 miles (48,000 km). For less than 60,000 miles (96,000 km) a year, grease the bearings every 6 months.</p>	Multi-Purpose Grease	O-617-A or O-617-B	1 or 2	Lithium 12-Hydroxy Stearate or Lithium Complex	Refer to the grease manufacturer's specifications for the temperature service limits.
	Trailer Axle Bearing	O-647	00	Lithium Complex	

① The recommended greasing interval is based on operating conditions, speeds and loads. Limited service applications may allow the recommended interval to be increased. Severe service applications may require the recommended interval to be reduced. For more information, contact a Meritor service representative.

# Section 10

## Transfer Case



### General Information

Transfer cases generate small metal wear particles at a fairly steady rate, especially during the break-in period. If these fine, but hard particles are allowed to circulate in the lubricant, internal components will wear at a much faster rate than normal.

### Magnets and Magnetic Drain Plugs

Most Meritor transfer cases are equipped with magnetic plugs having a minimum pick-up capacity of 20 ounces (0.57 kilograms) of low carbon steel.

**NOTE:** Meritor recommend replacing the magnetic drain plug each time the oil is changed. Use the correct part. Pipe plugs will leak if used as a drain plug.

The **magnetic drain plug** can be reused if, after cleaning, the plug has a minimum pick-up capacity of 20 ounces (0.57 kilograms) of low carbon steel.

### Breather

#### CAUTION

**Cover the breather when steam cleaning the housing. If the breather is not covered, water enters the housing and contaminates the oil.**

Breathers release pressure that builds up inside the transfer case during vehicle operation.

### Seals

#### CAUTION

**Always use the correct tools and procedures when replacing seals. If the correct tools and procedures are not used, the seal can be installed incorrectly and leak.**

Seals keep **lubricant in and dirt out** of a component. When they are worn or damaged, seals leak and produce low lubricant levels which may damage components.

### Temperature Indicators

#### CAUTION

**Meritor transfer cases may operate above 190° F (88° C) without damage. However, if the oil temperature reaches 250° F (121° C), stop the vehicle immediately and check for the cause of overheating. Maximum continuous running sump temperature should not exceed 225° F (107° C).**

### Oil Level



#### Check and Adjust Oil

#### WARNING

**To prevent serious eye injury, always wear safe eye protection when you perform vehicle maintenance or service.**

1. Make sure the vehicle is parked on a level surface.
2. Clean the area around the fill plug/fill cap. Remove the fill plug/fill cap from the transfer case. **Figure 10.1.**
3. The oil level must be even with the bottom of the fill plug hole or the top of the stand pipe.
  - a. If oil flows from the fill plug hole when the plug is loosened, the oil level is high. Let the oil drain to the correct level.
  - b. If the oil level is below the bottom of the fill plug hole or stand pipe, add the specified oil.
4. Install and tighten the fill plug to 35-50 lb-ft (47-68 N•m). 

### Drain and Replace Oil

1. Make sure the vehicle is parked on a level surface. Put a large container under the transfer case.
2. Remove the drain plug from the bottom of the transfer case. Drain and discard the oil properly. Clean the plug. **Figure 10.1**.
3. Install and tighten the drain plug to 35-50 lb-ft (47-68 N•m). 
4. Clean the area around the fill plug. Remove the fill plug from the transfer case.
5. Add the specified oil until the oil level is even with the bottom of the fill plug hole.
6. Install and tighten the fill plug to 35-50 lb-ft (47-68 N•m). 
7. Run the vehicle for 1/4 mile (0.4 km), then “top off” the oil level by adding oil to the fill opening.
8. Reinstall and tighten the fill plug to 35-50 lb-ft (47-68 N•m). 

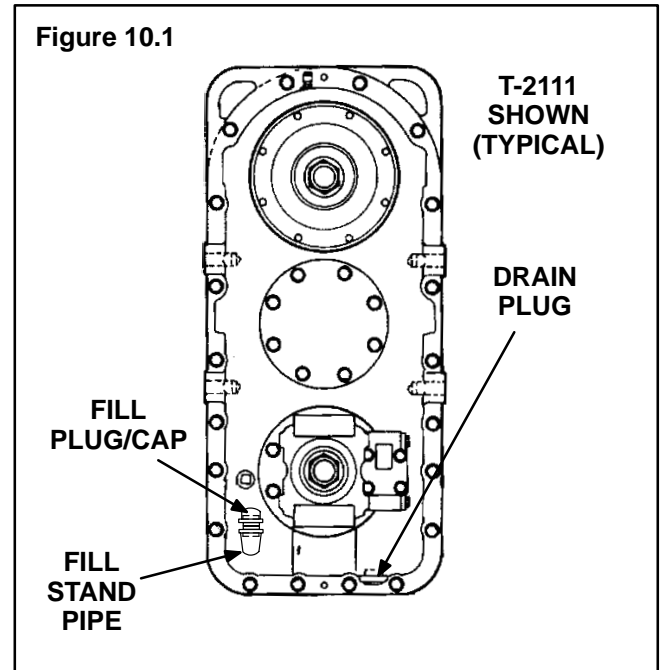

### Transfer Case Oil Change Intervals

Operation	On-Highway	Off-Highway
Check Oil Level	2,000 miles (3,200 km)	40 operating hours
Initial Oil Change	2,500 miles (4,000 km)	40-100 operating hours
Scheduled Oil Change	12,000-25,000 miles (19,000-40,000 km)	200-300 operating hours

# Section 10

## Transfer Case



### Transfer Case Oil Specifications <sup>①④⑤</sup>

Oil Description	Meritor Specification	A.P.I. Specification	Military Specification	SAE Grade	Outside Temperature
Petroleum GL-1 Oil with Rust and Oxidation Inhibitor <sup>②</sup>	_____	A.P.I. GL-1	_____	90W 80W	Above 10°F (-12°C) Above -15°F (-26°C)
Heavy Duty Engine Oil <sup>②</sup>	_____	A.P.I.-CD, CE, SF, or SG.	_____	50W 40W 30W	Above 10°F (-12°C) Above 10°F (-12°C) Above -12°F (-26°C)
Full Synthetic Oil <sup>③</sup>	O81	_____	_____	50W	Above -40°F (-40°C)
A.P.I. GL-5 (Axle Lube) <sup>①</sup>	DO NOT USE IN TRANSFER CASES				

- ① Do Not use multi-viscosity (I.E. 80/90W) GL-5 Gear Oil (axle lube).
- ② 90W GL-1 or 50W motor oil is same viscosity and commonly used above 10°F (-12°C).
- ③ Meritor Approved full synthetic oil for manual Meritor Transmissions are also approved for Meritor transfer cases. Use synthetic oil only if the T-case was initially filled with synthetic oil.
- ④ Do not mix or switch oil types—stay with oil that initially filled T-case.
- ⑤ Do not use multi-viscosity oils.

### Transfer Case Oil Capacities

Transfer Case Model	Oil Capacity	
	Pints <sup>①</sup>	Liters <sup>①</sup>
T-32	2.0	0.95
T-136	14.0	6.62
T-215	3.0	1.42
T-221	4.0	1.89
T-223	5.0	2.37
T-226	6.5	3.07
T-228	21.0	9.93
T-232	6.2	2.93
T-1138	13.5	6.38

Transfer Case Model	Oil Capacity	
	Pints <sup>①</sup>	Liters <sup>①</sup>
T-2111	3.0	1.42
T-2111-HD	5.0	2.37
T-2111-HT	5.0	2.37
T-2111-PD	10.0	4.73
T-2111-SD	5.0	2.37
T-2120	4.0	1.89
T-2120-RS	6.5	3.1
T-600	6.2	2.93

- ① Due to the varied transfer case configurations, these fill quantities are for reference only. The fill procedure for all transfer cases is as follows:
  1. Fill to the top of the stand pipe or fill hole.
  2. Run the vehicle for 1/4 mile (0.4 km).
  3. Then “top off” the oil level.
 The sump temperature should not exceed 225°F (107°C).



### General Information

**NOTE:** For a complete list of synthetic oil suppliers, refer to Meritor's Transmission Bulletin No. 9, "Lubricant Specifications." To order a copy of this bulletin, call Meritor's Customer Service Center and specify publication number TP-90114.

**NOTE:** Refer to Section 1 for recommended oil drain conditions based on used-transmission oil analyses.

Transmissions generate small metal wear particles at a fairly steady rate, especially during the break-in period. If these fine, but hard particles are allowed to circulate in the lubricant, along with external moisture and dirt, internal components will wear at a much faster rate than normal.

### Magnets and Magnetic Drain Plug

All Meritor transmissions have four magnets in the bottom of the main case. The magnets and magnetic plugs have a minimum pick-up capacity of 1.5 pounds (0.7 kilograms) of low carbon steel.

**NOTE:** Meritor recommends replacing the magnetic drain plug each time the oil is changed. Use the correct part. Pipe plugs will leak if used as a drain plug.

The **magnetic drain plug** can be reused if, after cleaning, the plug has a minimum pick-up capacity of 1.5 pounds (0.7 kilograms) of low carbon steel.

### Breather



**CAUTION**  
*Cover the breather when steam cleaning the transmission. If the breather is not covered, water can enter the main case and contaminate the oil.*

Baffle-type breathers help keep Meritor transmissions free from external moisture and dirt which can cause premature oil and component failure.

### Seals

Seals keep **lubricant in and dirt out** of a component. When they are worn or damaged, seals leak and produce damaging low lubricant levels.

Durable triple-lip seals, standard in Meritor transmissions, protect the quality and the levels of the lubricant and provide superior performance.



**CAUTION**  
*Always use seal driver 3256-Z-1014 (Kent-Moore Number J-39161) when replacing seals. If the correct tools and procedures are not used, the seal can be installed incorrectly and can leak.*

### Transmission Oil Coolers

Use a transmission oil cooler for either of the following:

- The transmission operating temperature is always more than 225°F (107°C) at continuous operation or reaches 275°F (135°C) during intermittent operation.
- The engine has a horsepower rating of 399 HP or more. Some aerodynamic vehicles with less than 399 HP may require a cooler due to the amount of air which flows over the transmission to dissipate heat.

### Temperature Indicator

The temperature indicator is optional on Meritor transmissions. The temperature sending unit is on the bottom right side of the main case. The normal operating temperature range is less than 225°F (107°C).

Use the temperature indicator gauge to check transmission operation. For example:

- If the temperature suddenly rises to 275°F (135°C) or more, check the transmission for the cause of the increase.
- When operating a vehicle on a mountain grade, if the temperature increases 50-75°F but returns to the normal operating temperature, this indicates a normal operating condition. If the temperature does not return to the normal range, check the transmission.

# Section 11

## Transmission



### Oil Level

#### Check and Adjust Oil

#### **⚠ WARNING**

*To prevent serious eye injury, always wear safe eye protection when you perform vehicle maintenance or service.*

1. Make sure of the following before checking the oil level. **Figure 11.1.**
  - a. The oil is at room temperature.
  - b. Wait ten minutes after the vehicle is parked before checking the level.
2. Make sure the vehicle is parked on a level surface.
3. Clean the area by the fill plug. Remove the fill plug from the side of the transmission.
4. Check for and correct any oil leaks.

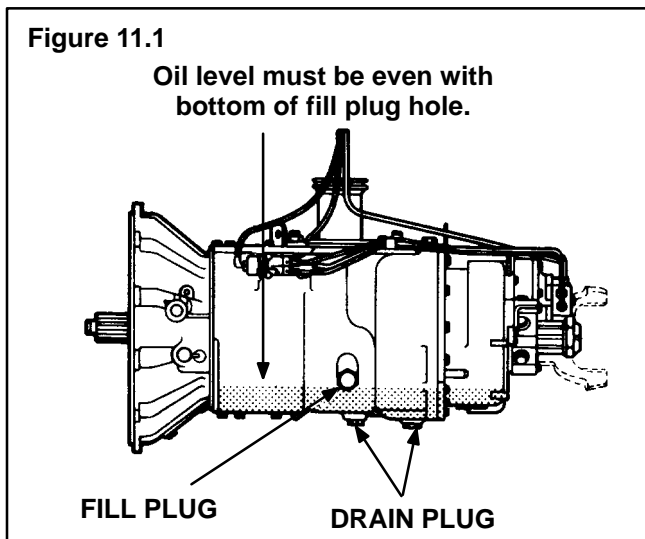

5. Check the oil level. The oil level must be even with the bottom of the fill plug hole.
  - If foam appears when the plug is removed, the oil is too hot to be checked. Install the plug and let the oil cool.
  - If oil flows from the hole when the plug is removed, the oil level is high. Let the oil drain until the oil is at the specified level.
  - If the oil level is below the bottom of the hole of the fill plug, add the specified oil.

6. Install and tighten the fill plug to 35-50 lb-ft (48-67 N•m). **T**
7. Operate the vehicle for 5 minutes. Check for leaks and correct operation.

### Drain and Replace Oil

#### **⚠ CAUTION**

*Adhere to the following lubrication guidelines to prevent damage to the transmission.*

- **Use only the specified oil. Do not use multi-viscosity engine oils or Extreme Pressure (EP) GL-5 gear oils.**
- **Use the same oil that is in the transmission. Do not mix oils.**
- **Check for low oil. The oil level must be even with the bottom of the fill plug for the oil to completely lubricate the transmission.**

**NOTE:** Drain the oil when the transmission is hot.

1. Make sure the vehicle is parked on a level surface. Put a large container under the transmission. Put a screen on top of the container.
2. Remove the drain plugs from the bottom of the transmission. Drain and discard the oil properly.
3. Inspect the screen on the top of the drain container for metal particles and damaged parts. Service the transmission as necessary.
  - If the transmission is disassembled or replaced and an oil cooler is used, remove the cooler.
  - Remove and discard the oil from the cooler and the oil lines.
  - Install the oil cooler and the lines.
  - Tighten the fittings to the specification of the vehicle manufacturer.
4. Install and tighten the drain plug to 35-50 lb-ft (48-67 N•m). **T**
5. Clean the area by the fill plug. Remove the fill plug from the side of the transmission.

**⚠ CAUTION**

*Use only the specified oil. Do not use multi-viscosity engine oils or Extreme Pressure (EP) GL-5 gear oils. Damage to components can result. The use of multi-viscosity or EP oils will void Meritor's warranty.*

6. Add the specified transmission oil through the fill plug hole. Add the oil until the oil level is even with the bottom of the fill plug hole.
7. Install and tighten the fill plug to 35-50 lb-ft (48-67 N•m). **T**
8. Operate the vehicle for five minutes. Check for correct operation.

## Manual Transmission Oil Change Intervals

Check Oil Level	Approved Petroleum Lubricants Oil Change	Approved Synthetic Oil Change
10,000 miles (16,000 km)	50,000 miles (80,000 km)	500,000 miles (800,000 km) <sup>①</sup>

## Manual Transmission Oil Specifications <sup>②</sup>

Oil Description	Meritor Specification	A.P.I. Specification	Military Specification Approval	SAE Grade	Outside Temperature
Heavy-Duty Engine Oil	_____	A.P.I. -CD, -CE, -SF, -SG, or -SH <sup>③</sup>	MIL-L-2104 D, E, OR F <sup>③</sup>	50 40 30	Above 10°F (-12°C) Above 10°F (-12°C) Above -15°F (-26°C)
Petroleum GL-1 Oil with Rust and Oxidation Inhibitor	_____	A.P.I. - GL-1	_____	90 80	Above 10°F (-12°C) Above -15°F (-26°C)
Full-Synthetic Oil <sup>④</sup>	O-81	-----	-----	50	Above -40°F (-40°C)

① This interval is for linehaul applications.

② Do not use multi-viscosity or EP (Extreme Pressure) GL-5 gear oils. **DO NOT MIX OILS IN THE TRANSMISSION.**

③ Current designations are acceptable.

④ Refer to Meritor's Transmission Bulletin No. 9, "Lubricant Specifications." To obtain a copy of this publication, call 800-535-5560 and order TP-90114.

# Section 11

## Transmission



### Manual Transmission Oil Capacities<sup>①</sup>

Model	Oil Capacity (Pints)	Length (In.)	Weight (Lbs.) <sup>②</sup>	PTO (% of Engine)
RM9-115A <sup>③</sup>	20	28.9	588	75.8
RM9-125A <sup>③</sup>	20	28.9	588	75.8
RM9-135A <sup>③</sup>	20.5	29.5	605	75.8
RM9-145A <sup>③</sup>	20.5	29.5	605	75.8
RM9-155A <sup>③</sup>	20.5	29.5	608	75.8
RMO9-125A	20	28.9	588	101.7
RMO9-135A	20.5	29.5	605	101.7
RMO9-145A	20.5	29.5	605	101.7
RMX9-125A <sup>③</sup>	20	28.9	588	101.7
RMX9-135A <sup>③</sup>	20.5	29.5	605	101.7
RMX9-145A <sup>③</sup>	20.5	29.5	605	101.7
RMO9-115B	20	28.9	588	87.1
RMO9-125B	20	28.9	588	87.1
RMO9-135B	20.5	29.5	605	87.1
RMO9-145B	20.5	29.5	605	87.1
RMX9-115B <sup>③</sup>	20	28.9	588	87.1
RMX9-125B <sup>③</sup>	20	28.9	588	87.1
RMX9-135B <sup>③</sup>	20.5	29.5	605	87.1
RMX9-145B <sup>③</sup>	20.5	29.5	605	87.1
RMX9-155B <sup>③</sup>	20.5	29.5	608	87.1
RMX9-115R <sup>③</sup>	20	28.9	588	101.7
RMX9-125R <sup>③</sup>	20	28.9	588	101.7
RMX9-135R <sup>③</sup>	20.5	29.5	605	101.7
RMX9-145R <sup>③</sup>	20.5	29.5	605	75.8

Model	Oil Capacity (Pints)	Length (In.)	Weight (Lbs.) <sup>②</sup>	PTO (% of Engine)
RM10-115A <sup>③</sup>	20	28.9	588	75.8
RM10-125A <sup>③</sup>	20	28.9	588	75.8
RM10-135A <sup>③</sup>	20.5	29.5	605	75.8
RM10-145A <sup>③</sup>	20.5	29.5	605	75.8
M-14F10A-M16 <sup>③</sup>	20.5	29.5	605	75.8
RM10-155A <sup>③</sup>	20.5	29.5	608	75.8
RD10-145A	20.5	29.5	605	75.8
RMX10-115A <sup>③</sup>	20	28.9	588	101.7
RMX10-125A <sup>③</sup>	20	28.9	588	101.7
RMX10-135A <sup>③</sup>	20.5	29.5	605	101.7
RMX10-145A <sup>③</sup>	20.5	29.5	605	101.7
MO-14F10A-M16 <sup>③</sup>	20.5	29.5	605	101.7
RMX10-155A <sup>③</sup>	20.5	29.5	608	101.7
RMX10-165A <sup>③</sup>	20.5	29.5	608	101.7
RMX10-115C <sup>③</sup>	20.5	29.5	605	98.2
RMX10-125C <sup>③</sup>	20.5	29.5	605	98.2
RMX10-135C <sup>③</sup>	20.5	29.5	605	98.2
RMX10-145C <sup>③</sup>	20.5	29.5	605	98.2
MO-14F10C-M16 <sup>③</sup>	20.5	29.5	605	98.2
RMX10-155C <sup>③</sup>	20.5	29.5	608	98.2
RMX10-165C <sup>③</sup>	20.5	29.5	608	98.2
MO-16F10C-M18 <sup>③</sup>	20.5	29.5	608	98.2
RMO13-145A	22	32.4	666	75.8

- ① Oil capacities are approximate. Fill the transmission to the bottom of the fill plug hole. On transmissions equipped with an oil pump and/or oil cooler, operate the engine for five minutes after the initial fill and check the oil level again.
- ② Weights are approximate, less clutch housing, shift controls, output yoke and lubricant.
- ③ Available with Meritor's Engine Synchro Shift™ (ESS) System. For ESS transmission models, replace the "M" in the above model numbers with an "S".

## Greasing Wheel Bearings

### **CAUTION**

*To prevent serious eye injury, always wear safe eye protection when you perform vehicle maintenance or service.*

### **WARNING**

*Support the vehicle with safety stands. Do not work under a vehicle only supported by jacks. Jacks can slip or fall over and cause serious personal injury.*

**NOTE:** For specific service information refer to the correct maintenance manual listed in the "References" chart at the front of this manual.

1. Raise the vehicle so that the wheels are off the ground. Support the vehicle with safety stands.
2. Remove the tire and wheel assembly. Remove and disassemble the hub.
3. Use the correct cleaning solvent to remove the old grease from all parts. Discard the seals. Inspect the wheel bearings for wear or damage. Replace worn or damaged bearings.
4. Before installing the wheel bearings, lubricate the bearing journals on the spindle with the grease that is used for the bearings. **Figure 12.1.**
5. Use a pressure packer to force the specified grease from the large end of the cones into the cavities between the rollers and cage. Pack the hub between the bearing cups with grease to the level of the smallest diameter of the cups. If a pressure packer is not available, grease the bearings by hand.
6. Install the inner and outer bearing cones into the cups in the hubs. The bearing cups must be pressed tight against the shoulder in the hubs.
7. Install new wheel seals in the hubs.
8. Install the hub and the wheel and tire assembly. Install the outer wheel bearing cone in the hub. Install the adjusting nut.
9. Adjust the wheel bearings.

**Figure 12.1**

### TYPICAL GREASE LUBRICATED WHEEL BEARINGS

LUBE

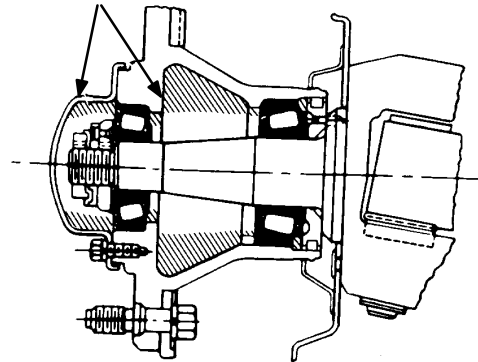

# Section 12

## Wheel Bearings and Wheel Ends



### Checking the Oil Level on Wheel Bearings

**NOTE:** If you cannot observe the oil level because the sightglass is stained, remove the fill plug, check the oil level with your finger and follow the procedures for Step 2, below. Replace the stained sightglass at your earliest maintenance opportunity.

1. Check the oil level on the cap.
2. If the oil level is more than 1/4-inch (6mm) below the specified level on the cap, remove the fill plug.
3. Add the specified oil to the specified level.  
**Figure 12.2.**
4. Install the fill plug.

### Drive Axle Hubs Without Fill Holes

1. Pour the specified amount of lubricant through the carrier or housing bowl oil fill hole.
2. Tilt the axle to the right and to the left to let the oil flow into the hub cavities. Keep the axle tilted for one minute in each position.
3. With the axle in the level position, add the specified oil so that the level is even with the bottom of the fill plug hole.
4. Install and tighten the fill plug.

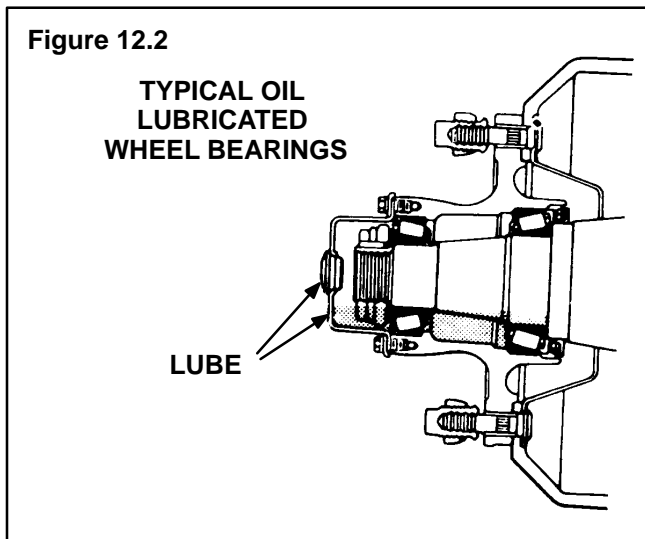

### Wheel End Axle Greasing Intervals and Specifications

Greasing Interval	Grease	Meritor Specification	NLGI Grade	Grease Description	Outside Temperature
Whichever comes first: Replacing Seals Relining Brakes On-Highway: 30,000 miles (48,000 km) On/Off Highway and Off-Highway: Twice a year	Multi-Purpose Grease	O-617-A (preferred) or O-617-B (acceptable)	1 or 2	Lithium 12-Hydroxy Stearate or Lithium Complex	Refer to the grease manufacturer's specifications for the temperature service limits.

### Wheel End Oil Change Intervals and Specifications

Operation	On-Highway	Off-Highway
<b>Check Oil Level</b>	1,000 miles (1,600 km)	1,000 miles (1,600 km)
<b>Petroleum Oil Change</b>	Whichever comes first. Seals replaced. Brakes relined. 100,000 miles (160,000 km). Once a year.	Whichever comes first. Seals replaced. Brakes relined. Once a year.
<b>Synthetic Oil Change</b>	-----	-----

Meritor Specifications	Military Specifications Approval	Oil Description	Outside Temperature			
			°F		°C	
			Min.	Max.	Min.	Max.
O-76A, Gear Oil	MIL-L-2105D or MIL-PRF-2105-E	GL-5, SAE 85W/140	10	None	-12	None
O-76D, Gear Oil		GL-5, SAE 80W/90	-15	None	-26	None
O-76E, Gear Oil		GL-5, SAE 75W/90	-40	None	-40	None
O-76J, Gear Oil		GL-5, SAE 75	-40	35	-40	2
Heavy-Duty Engine Oil	MIL-L-2104D, E, or F	A.P.I. -CD, -CE, -SF, or -SG, SAE, SAE 40 or 50 ①	10	None	-12	None
Heavy-Duty Engine Oil	MIL-L-2104D, E, or F	A.P.I. -CD, -CE, -SF, or -SG, SAE 30 ②	-15	None	-26	None

① Current designations are acceptable. Multi-weight engine oils are acceptable if the SAE rating ends in a 40 or 50.

② Current designations are acceptable. Multi-weight engine oils are acceptable if the SAE rating ends in a 30.

# Section 13

## List of Lubricants



### Grease Lubricants <sup>①</sup>

Meritor Specification	Grease	Typical Application	NLGI Grade	Grease Description	Outside Temperature
O-616	Brake Grease	Cam Brake Anchor Pins, Mechanical Brake Anchor Pins	2	Clay Base	②
O-616-A	Brake Grease	Air Disc Brake Caliper, Automatic Slack Adjuster, Wedge Brake Components	1	Clay Base	Down to -40°F (-40°C)
O-617-A or O-617-B	Multi-Purpose Grease	Cam Brake Chamber Brackets, Cam Brake Hold Down Clips, Cross Tube Ends, Drag Link, Wheel Bearings, King Pins and Bushings, Knuckle Bushings, Manual Slack Adjuster, Steering Arm, Ball Studs, Tie Rod End Ball Studs, Trailer Axle Wheel Bearings, Wedge Brake Hold-Down Clips, Wedge Brake Shoe Contacts at Anchors.	1 or 2	Lithium 12-Hydroxy Stearate or Lithium Complex	②
O-634-B	Universal Joint Grease	Driveshaft Slip Yokes, Driveshaft Splines, Driveshaft Universal Joints	2	Lithium 12-Hydroxy Stearate with Molybdenum Disulfide	②
O-637*	Special Rust-Preventing Brake Grease	Air Disc Brake Slide Pin, Splines and Clevis Pins, Cam Brake Camshaft Splines	1 1/2	Calcium	②
O-645	Low-Temperature Brake Grease	Air Disc Brake Caliper, Automatic Slack Adjuster, Wedge Brake Components	2	Synthetic	Down to -65°F (-54°C)
O-647	Trailer Axle Bearing Grease	Trailer Axle Wheel Bearings	00	Synthetic	②
O-661	High-Temperature Multi-Purpose Wheel Bearing Grease	Clutch Release Bearing	3	Lithium Complex	②
O-692	Automatic Slack Adjuster Grease	Automatic Slack Adjuster	1 & 2	Lithium Base	Down to -40°F (-40°C)

① Grease recommendations are based on commercial products that have given satisfactory results in normal operation. However, there are many proprietary grease products on the market which will perform satisfactorily and may be preferable because of supply problems, common usage for other truck components, etc. When such products are recommended by reputable suppliers for the specific lubrication of our components, Meritor has no objections, provided that these substitute products are equal to or better than Meritor recommendations in lubrication properties, water resistance, corrosion protection, high and low temperature characteristics, oxidation stability, shear stability, etc. All substitute products are subject to Meritor approval. For more information, contact a Meritor service representative.

② Refer to the manufacturer's specifications for the temperature service limits.

\*Do not mix O-637 calcium-base, corrosion-control grease with other greases.



### Oil Lubricants

Meritor Specification	Oil	Typical Application	Military Specification Approval	Oil Description	Outside Temperature			
					°F		°C	
					Min.	Max.	Min.	Max.
O-62	Petroleum Oil	Transfer Case	-----	SAE 90	10	None	-12	None
O-63	Petroleum Oil	Transfer Case	-----	SAE 140	40	None	4	None
O-76A	Gear Oil	Front Driving Axle, Front Driving Axle Wheel Bearings, Non-Driving Axle Wheel Bearings, Planetary Axle, Rear Driving Axle, Trailer Axle Wheel Bearings	MIL-L-2105D or MIL-PRF-2105-E	GL-5, SAE 85W/140	10	None	-12	None
O-76D	Gear Oil	Front Driving Axle, Front Driving Axle Wheel Bearings, Non-Driving Axle Wheel Bearings, Planetary Axle, Rear Driving Axle, Trailer Axle Wheel Bearings		GL-5, SAE 80W/90	-15	None	-26	None
O-76E	Gear Oil	Front Driving Axle, Front Driving Axle Wheel Bearings, Non-Driving Axle Wheel Bearings, Planetary Axle, Rear Driving Axle, Trailer Axle Wheel Bearings		GL-5, SAE 75W/90	-40	None	-40	None

# Section 13

## List of Lubricants



Meritor Specification	Oil	Typical Application	Military Specification Approval	Oil Description	Outside Temperature			
					°F		°C	
					Min.	Max.	Min.	Max.
O-76J	Gear Oil	Front Driving Axle, Front Driving Axle Wheel Bearings, Non-Driving Axle Wheel Bearings, Planetary Axle, Rear Driving Axle, Trailer Axle Wheel Bearings	MIL-L-2105D or MIL-PRF-2105-E	GL-5, SAE 75W	-40	35	-40	2
O-76L	Gear Oil	Front Driving Axle, Front Driving Axle Wheel Bearings, Non-Driving Axle Wheel Bearings, Planetary Axle, Rear Driving Axle, Trailer Axle Wheel Bearings		GL-5, SAE 75W/140	-40	None	-40	None
O-76M	Full Synthetic Oil	Rear Driving Axle, Trailer Axle Wheel Bearings		GL-5, SAE 75W/140	-40	None	-40	None
O-76N	Full Synthetic Oil	Rear Driving Axle, Trailer Axle Wheel Bearings		GL-5, SAE 75W/90	-40	None	-40	None
O-81	Full Synthetic Oil	Transmission		-----	SAE 50	-40	None	-40
-----	Heavy Duty Engine Oil	Transmission	MIL-L-2104 -D, -E, or -F	A.P.1. -CD, -CE, -SF, -SG or -SH SAE 50	10	None	-12	None
-----	Heavy Duty Engine Oil	Transmission		A.P.1. -CD, -CE, -SF, -SG or -SH SAE 40	10	None	-12	None
-----	Heavy Duty Engine Oil	Transmission		A.P.1. -CD, -CE, -SF, -SG or -SH SAE 30	-15	10	-26	-12
-----	Petroleum Gear	Transmission		A.P.I.-GL-1 SAE90	10	None	-12	None
-----	Petroleum Gear	Transmission		A.P.I.-GL-1 SAE80	-15	None	-26	None
-----	Petroleum Gear	Transmission						



**MERITOR™**  
A Heritage of Rockwell Technology

**Meritor Heavy Vehicle Systems, LLC**  
2135 West Maple Road  
Troy, MI 48084 USA  
800-535-5560  
<http://www.meritorauto.com>

Information contained in this publication was in effect at the time the publication was approved for printing and is subject to change without notice or liability. Meritor Heavy Vehicle Systems, LLC, reserves the right to revise the information presented or discontinue the production of parts described at any time.

©Copyright 1999  
Meritor Automotive, Inc.  
All Rights Reserved

Printed in the U.S.A.  
Please Recycle

Maintenance Manual No. 1  
Revised 3/99  
VFTIS/Meritor