



Limitorque
Making valve control easier™

Electric Actuators

Simplify Valve Control



Experience In Motion



Limitorque satisfies today's needs for valve actuation for many industries from Nuclear Power to Water Treatment.





This GS-350 actuator was installed at Pearl Harbor in 1941 and removed from service in June of 2012. It was one of many GS actuators controlling the dry docks.

Over 70 years of service and still working when removed.

Yes, they were there, on that day.



Valve Applications for Actuators



Applications: Linear Multi-Turn

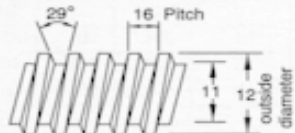

Acme Stem Dimensions
(Left Hand Stem Shown)

- Gate Valve
- Globe Vales

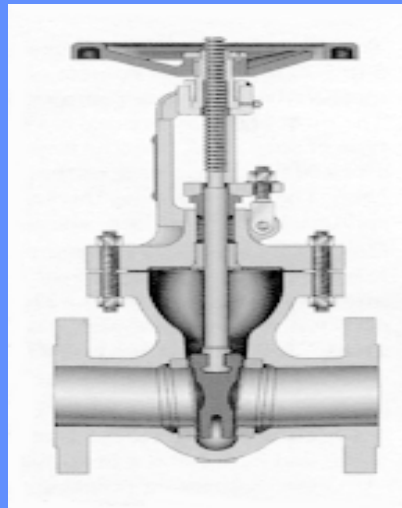

Rising Stem :Gate require the actuator to support the Thrust Load of the gate. Stem bushings are threaded to match gate stem.

Non-Rising Stem /Keyed shaft Applications :
Gate of Gear Drives- the actuator only provides torque.



Actuator Sizing

Stem Thread Terminology

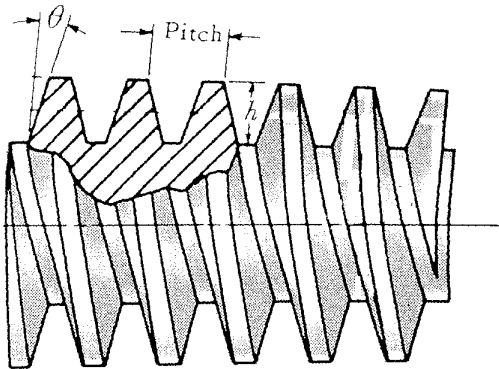

Pitch is the number of threads linearly along the stem. Expressed as a fraction (distance in inches/number of threads)

Lead is the number of revolutions or turns around the stem for an increment of travel in inches. Expressed as a fraction (increment of travel/turns)

Common Valve Stem Threads P/L's

$$\frac{1}{4} P - \frac{1}{4} L = 4T/\text{inch}$$

$$\frac{1}{4} P - \frac{1}{2} L = 2T/\text{inch}$$

$$\frac{1}{3} P - \frac{1}{3} L = 3T/\text{inch}$$

$$\frac{1}{3} P - \frac{2}{3} L = 1.5T/\text{inch}$$

$$\frac{2}{5} P - \frac{2}{5} L = 2.5 T/\text{inch}$$



Actuator Thrust Applications



pa



L120 85 and Smaller and All MX units use a (A1) Thrust base for all thrust applications.

L120-190 and Larger All V and S gears use Top Entry stem nut for Thrust Applications

L120-85 Illustrated Parts Breakdown (continued)

Thrust Base Group

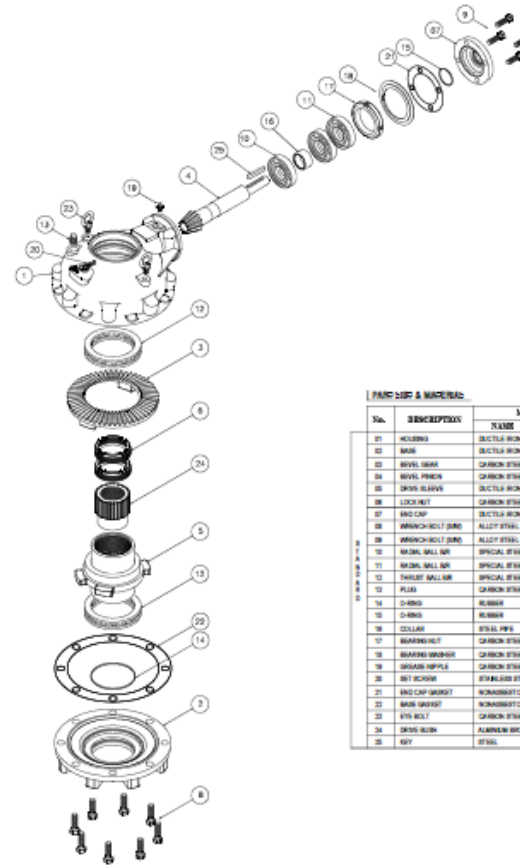
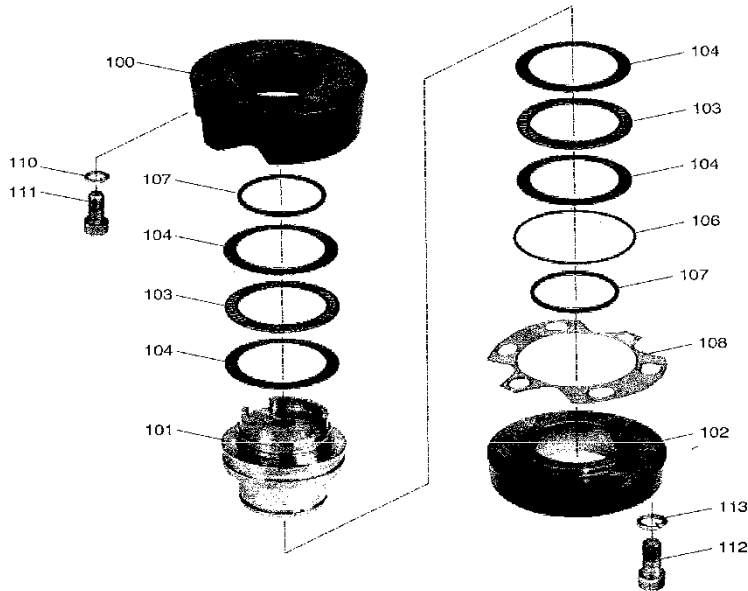

PART LIST & MATERIALS

No.	DESCRIPTION	MATERIAL	QTY
01	WASHER	DUCTILE IRON A306 8-40-12	1
02	WASHER	DUCTILE IRON A306 8-40-12	1
03	WASHER	CARBON STEEL A307 10-40	1
04	WASHER	CARBON STEEL A307 10-40	1
05	WASHER	DUCTILE IRON A306 8-40-12	1
06	LOCK WASH	CARBON STEEL A307 10-40	2
07	WASHER	DUCTILE IRON A306 8-40-12	1
08	WASHER	ALLOY STEEL A322 4-40	1/2
09	WASHER	ALLOY STEEL A322 4-40	4
10	WASHER	SPECIAL ST STEEL A306 12-100	1
11	WASHER	SPECIAL ST STEEL A306 12-100	1/2
12	WASHER	SPECIAL ST STEEL A306 12-100	2
13	WASHER	CARBON STEEL A307 10-40	1
14	WASHER	ALUMINUM	2
15	WASHER	ALUMINUM	1
16	WASHER	STEEL 10-40	1
17	WASHER	CARBON STEEL A307 10-40	1
18	WASHER	CARBON STEEL A307 10-40	1
19	WASHER	CARBON STEEL A307 10-40	1
20	WASHER	STEEL 10-40	1
21	WASHER	ALUMINUM	1
22	WASHER	ALUMINUM	1
23	WASHER	CARBON STEEL A307 10-40	2
24	WASHER	ALUMINUM	1
25	WASHER	STEEL	1



Globe Valve – Rising Rotating Application

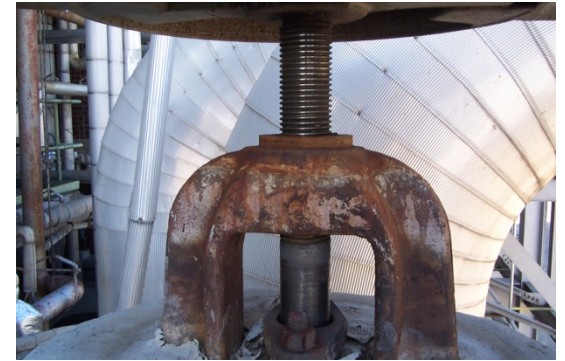
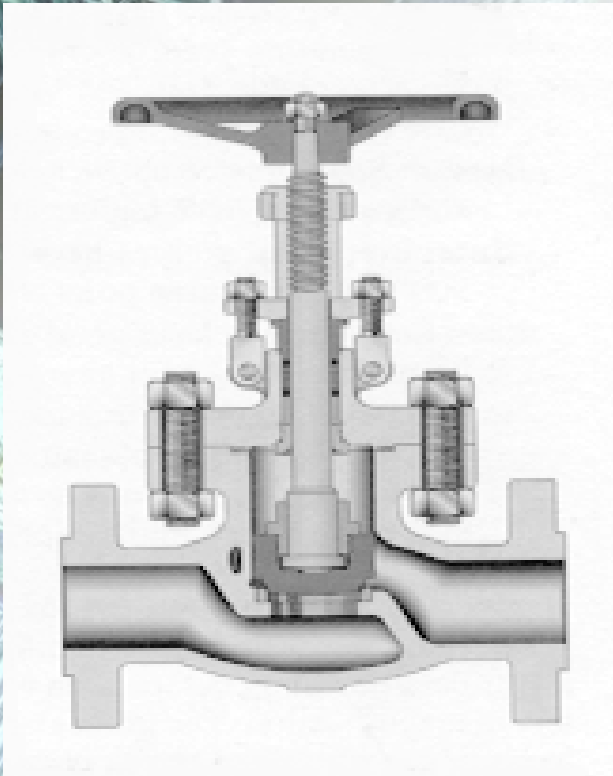

Actuation is by driving the valve stem with **TORQUE** and allowing it to rise as it rotates inside the actuator.

Splined, double keyed or hexed bushing are normally attached to the valve stem with a mating drive in the actuator.

Must provide enough travel room in the actuator's drive sleeve to allow full valve travel.



■ Making Valve Control Easier™

■ Application: Quarter Turn Valves

Actuators provide torque to stroke and seat valves and **travel limits** to prevent valves from being driven past the seating area.

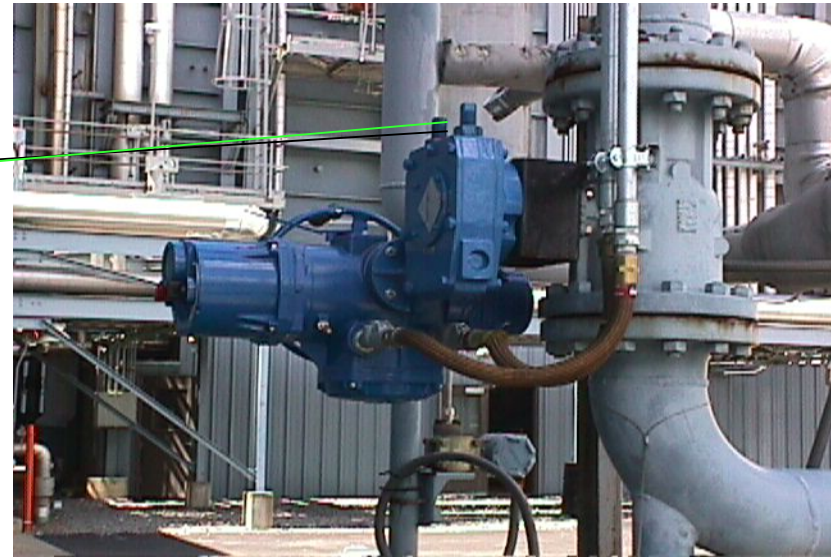

■ Butterfly

■ Ball

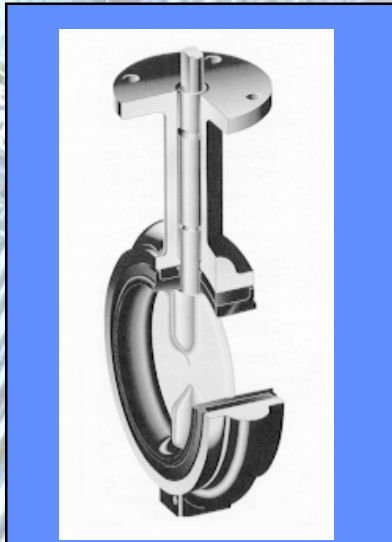

Actuator connects to valve stem with keyed or stem flats.

Speeds: 30 -120 Seconds are common.

Limatorque
Making valve control easier™



Valve Seating Methods



Valve Seating Options

Torque Seating:

- Motor turned off by Torque Switch when force is reached.
- Limit Switch is used to turn on /off position lights or indication
- Torque Switch also provide protection in travel.
- ** Locking Gearing required on Electro-Mech Actuators but not required on MX. (Torque Hammer)



Position Seating:

- Motor turned off by Limit Switch when closed POSITION is reached.
- Limit Switch is used to turn on /off position lights or indication.
- Torque Switch is protection.
- Locking Gearing is not require on MOST application.





Electro-Mechanical Style Actuators and Basic Controls.

The Reversing Starter is the heart of MOV controls. It's either in the actuator (Integral) or in the plants systems (NCU)

- It drives the motor open or close based on control power.
- It turns the motor off when control power is interrupted by LS/TS, Motor Thermal.
- It is electrically and mechanically interlocked so the motor can not be powered in both directions at the same time

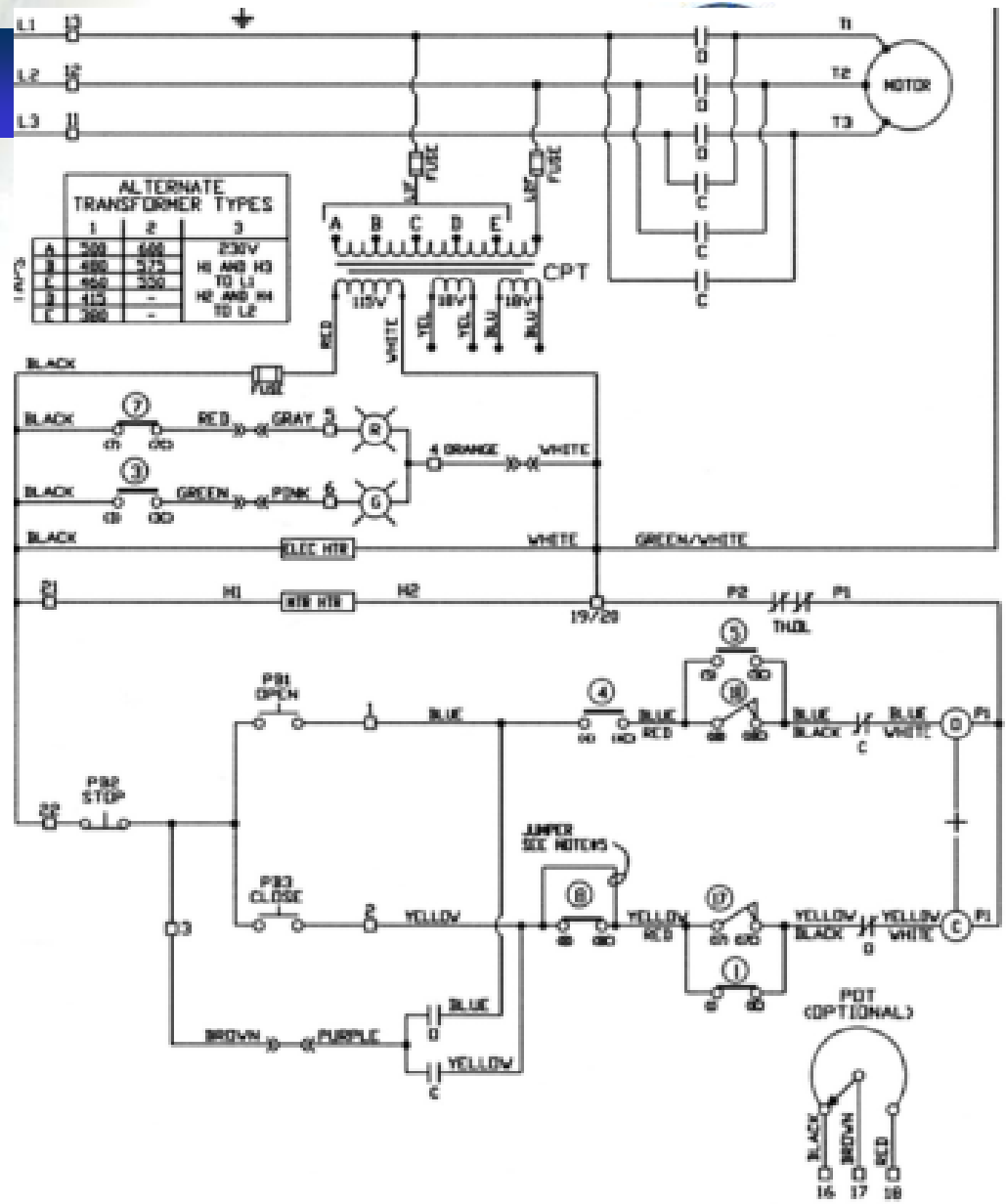



Reversing contactor

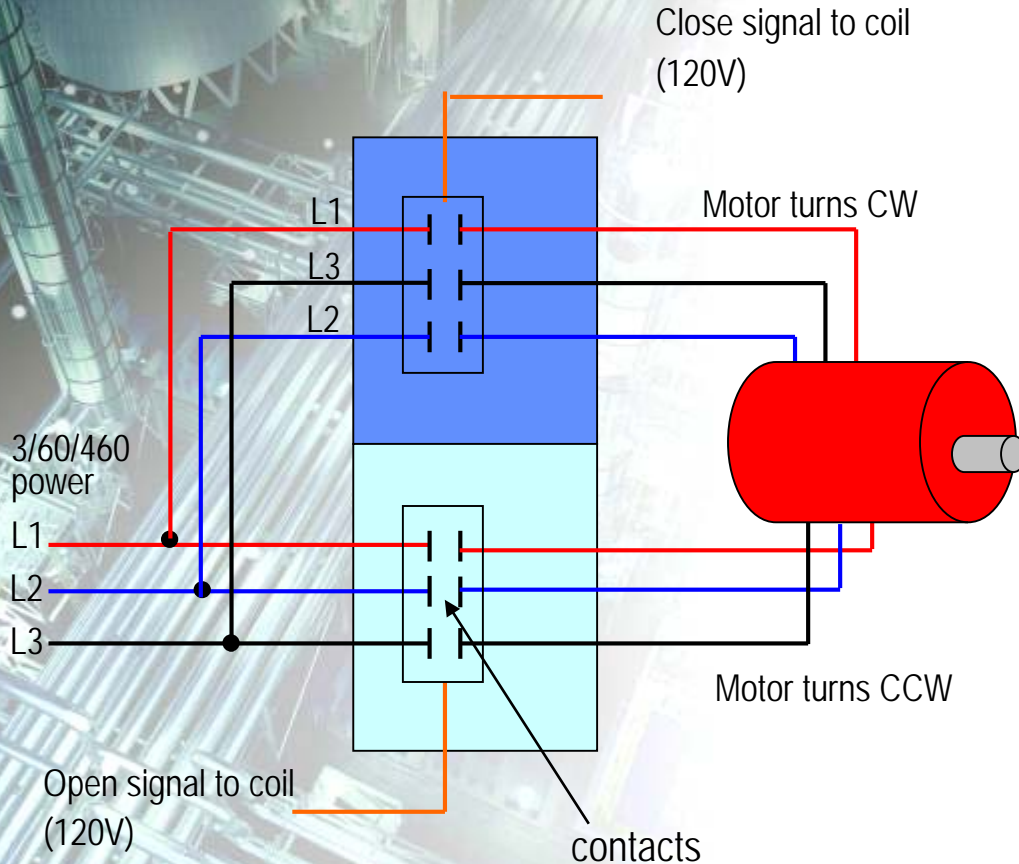

- On 3 phase power- motor direction is controlled by switching the phasing order of any two legs, normally L2/L3.
- Improper power phasing to the actuator will cause a big problem, unless there is phase protection or correction.
- Some applications or design may use Solid State Reversing Controls (QX and High Modulation)



NCU – No Controls Unit

Common for Power and Refineries with MCC (Motor Control Centers)

Includes:

- Limit SW
- Torque SW-
- Compartment Heater
- Terminal Strip.

Requires motor controls to be provided in a remote location and normally by others.

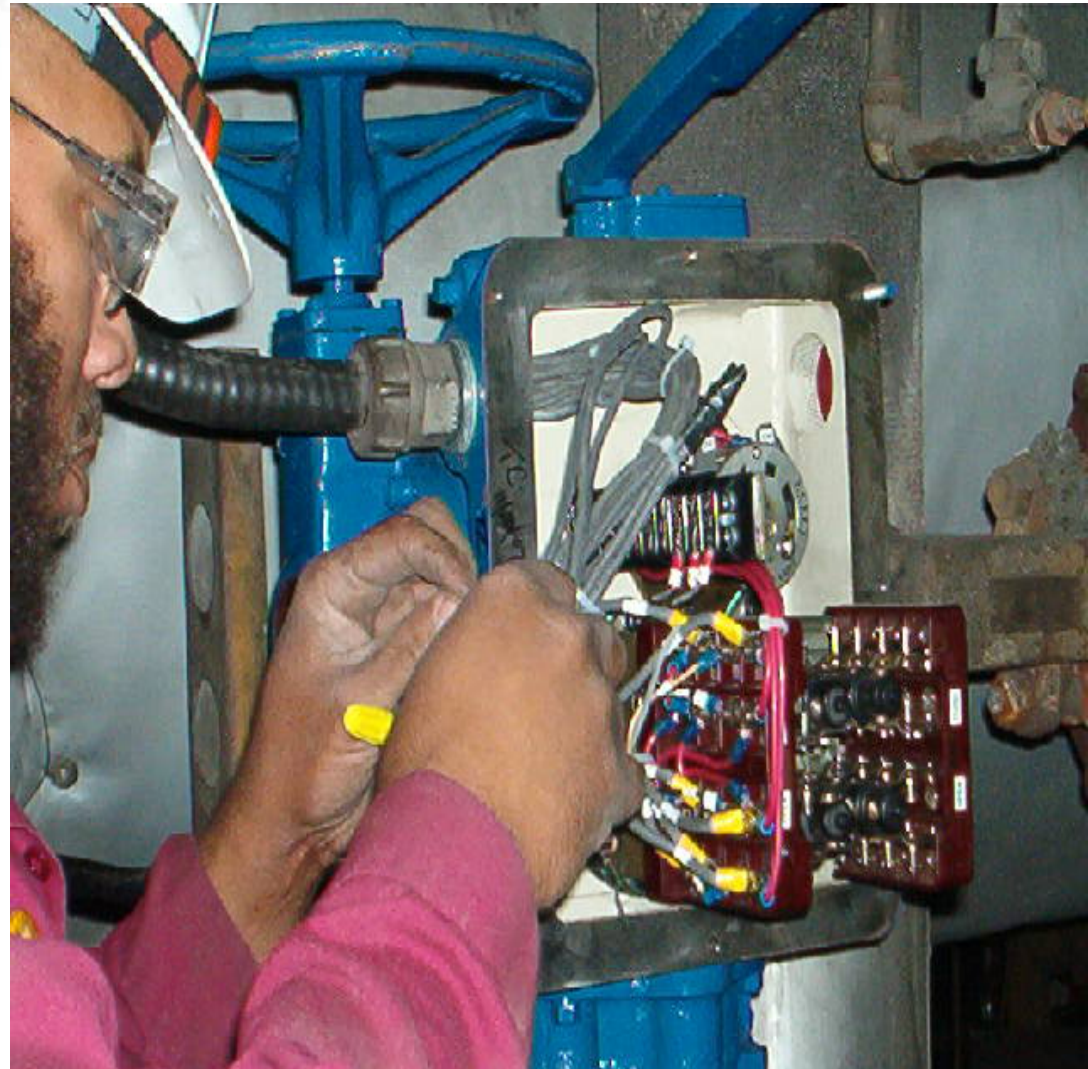



■ L120-10, 20, 40 & 85

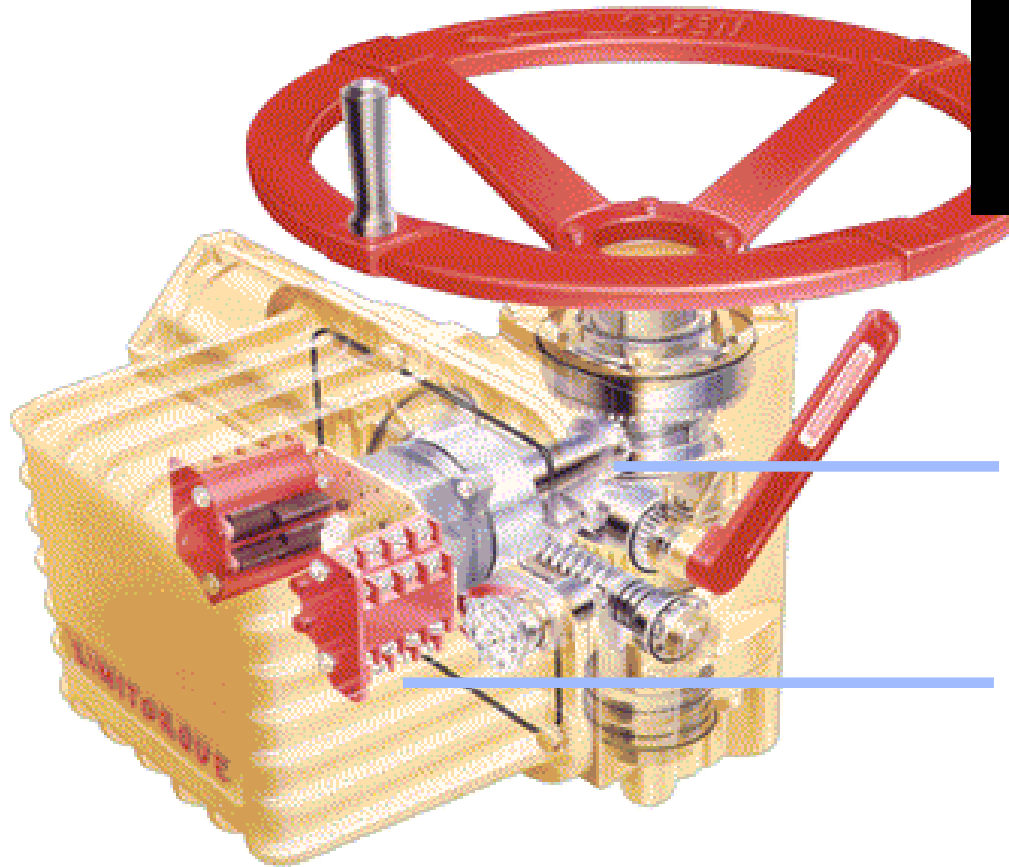

Enclosure:
 WP (Nema 4)
 XP (Class1,C&D, Dive
 1&2: Class II, Group E,F,
 G)
 Other options – See UPL

- All metallic lubricated
- gearing shaft supported
- in anti-friction bearings
- 4 position, 16-contact
- geared limit switch.
- Gear train fully enclosed





Mechanical Actuator

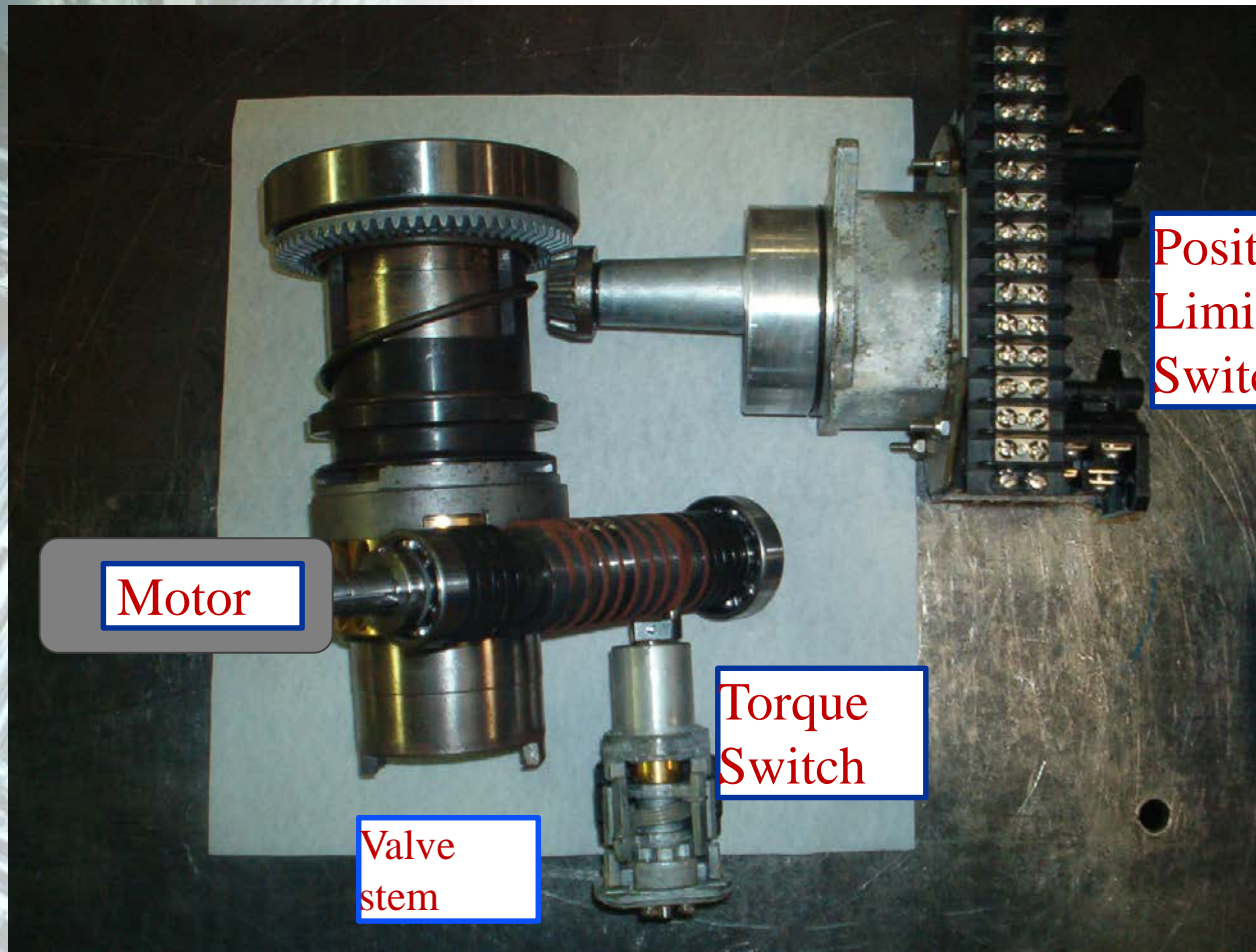

Motor

Valve stem

Torque Switch

Position Limit Switch



SMB and L120 Electro Mechanical Products

These products use mechanical, gear driven limit and torque switch and require covers removed for calibration and set up.

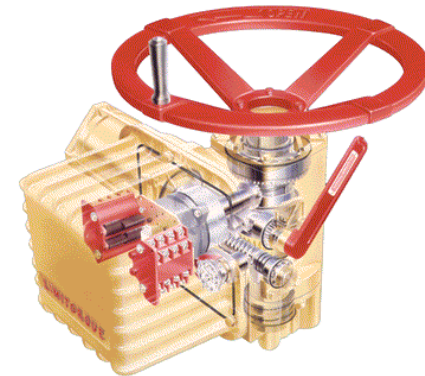
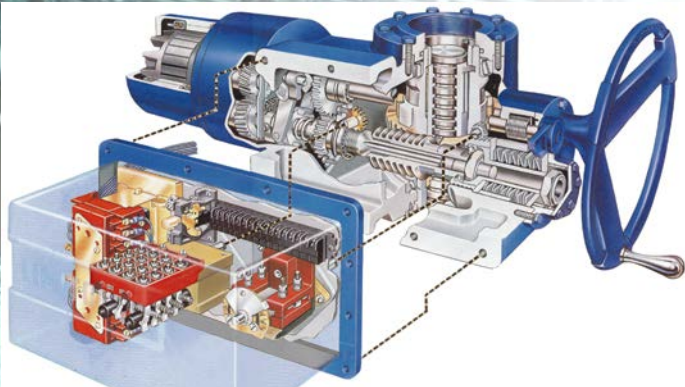

- 16 Contact Geared Limit Switch
- Mechanical Torque Sw.
- Motors for 1 phase, 3 phase and DC power
- Many Control Options





Motors - Not your standard motors

All actuators use Limited Duty Motor?

- Short run cycles 5 seconds to 15 minutes
- High Starting Torque
- Low inertia.
- Lower mid stroke torque (20% run)
- Modulation suitable- based on starts per hour.
- Extended run loads or time may require special motors, insulation, thermal.



■ Electro-Mechanical Actuators

■ Motor Designs

- A wide range of motor options to meet varied installation requirements
 - AC Motors
 - 1 phase, 1-60-115v & 230v
 - 3 phase, 3-60-208v to 575v
 - DC Motors
 - 125v or 250v
 - Also available with 120 PSI Air Motors.
- Motor design options include extended duty and/or extended dynamic torque



■ Electro-Mechanical Actuators

- **Cast iron or ductile iron gear housings**
- **Locking gearing**
- **Hammer blow effect**
- **Lost motion at the drive sleeve overcomes sticking valves by applying a “hammer blow” effect to the stem nut/valve stem interface**
- **Handwheel Operation - WHAT IS RIM PULL????**
- **Position Control (Limit Switch)**
- **Torque Control (Torque Switch)**
- **Position Indication – Dial, ohms and or 4-20mA output**
- **Control options (relays, Coker options, Phase protection, Local/Remote control stations)**



MX Accutronix - The latest technology in valve control



- ◆ Non-intrusive set-up
- ◆ No special setting tools
- ◆ User-friendly LCD display
- ◆ Text display
- ◆ More control flexibility
- ◆ Fast commissioning
- ◆ Smart network capabilities



Electronic – Nonintrusive Actuator

(all external setup and calibration)



Limitorque- MX

Valve control that meets and exceeds the features requested by our Customers around the world and provides low cost of ownership

- ✓ Simple to install and commission
- ✓ Easy to operate
- ✓ Minimum maintenance





MX Multi-turn actuator

Double-sealed Termination chamber

Motor gear attachment

Plug-in connectors

External Connection block

Conduit Entries (3)

Electronic Torque sensing

Absolute Position encoder

Control panel display

Local Control switches

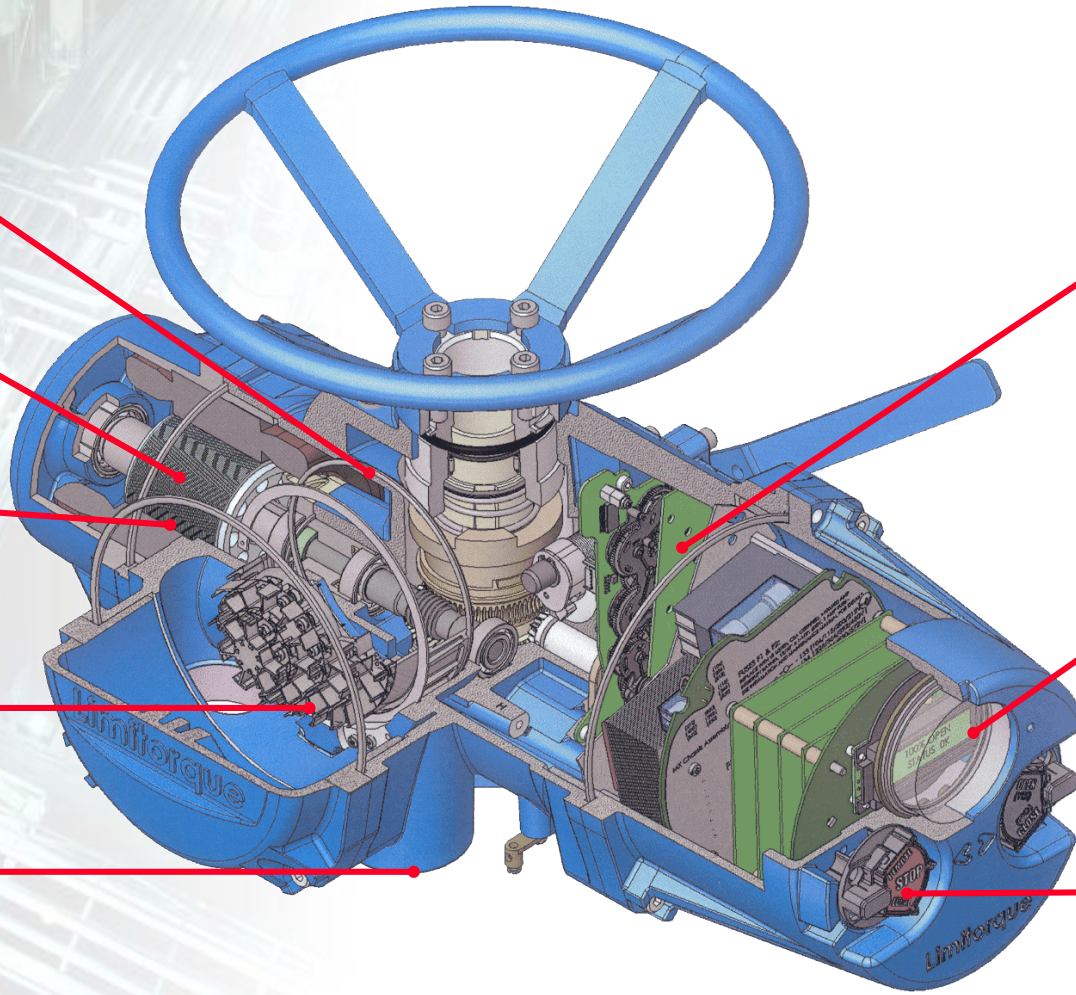



Absolute Encoder for control of valve position

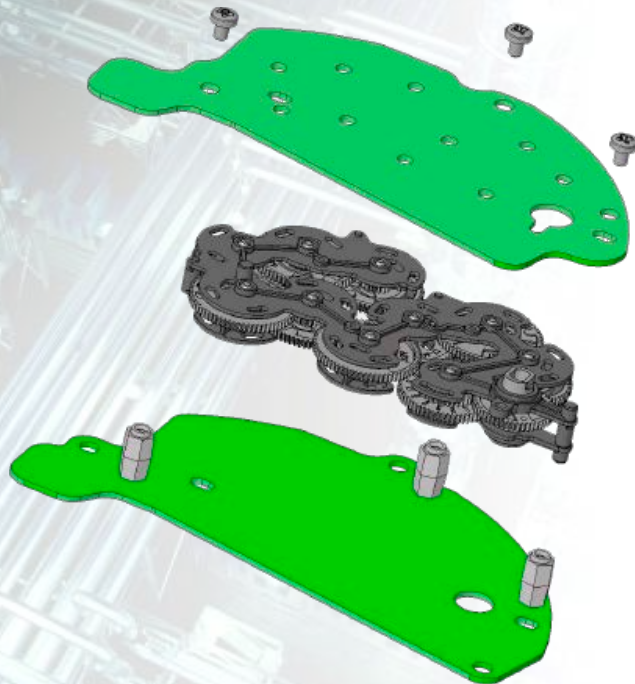

- **Patented Absolute encoder**
- **Accurate and continuous sensing of valve position:**
- **No batteries or back-up power supply required**
- **No loss of calibration if power fails**
- **Non-contacting optical sensing**
- **18-bit resolution; ~10,000 drive sleeve turns**
- **100% repeatable**
- **Gear driven from drive sleeve**
- **Built-In-Self-Test (B.I.S.T.) features**

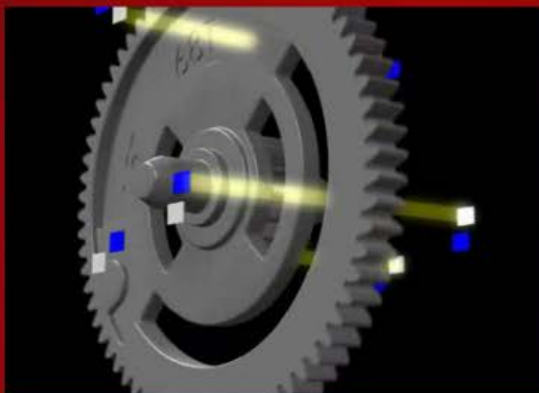

Q: How does the MX understand exactly where the valve is positioned — even after a power failure?

A: The MX's Patent-Pending Absolute Encoder.

LED Lights and receivers on PC boards mounted on each side of the encoder gears detect detailed location of each encoder gear. The standard encoder support up to 10,000 input turns to a valve or gear box.



Torque Sensing

- **Electronic Torque Control**
- **Simple to set and adjust without removing any covers; 40% to 100%**
- **Torque control by monitoring speed, voltage and motor temperature (Motor Thermistor)**
- **Advantages to torque sensing**
 - ▶ **Jam protection and retry is standard**
 - ▶ **Torque Profile is standard in Diagnostics with FFT capabilities**
 - ▶ **ATT (Analog Torque Transmitter) Option (4-20 mA) with graphics capability!**

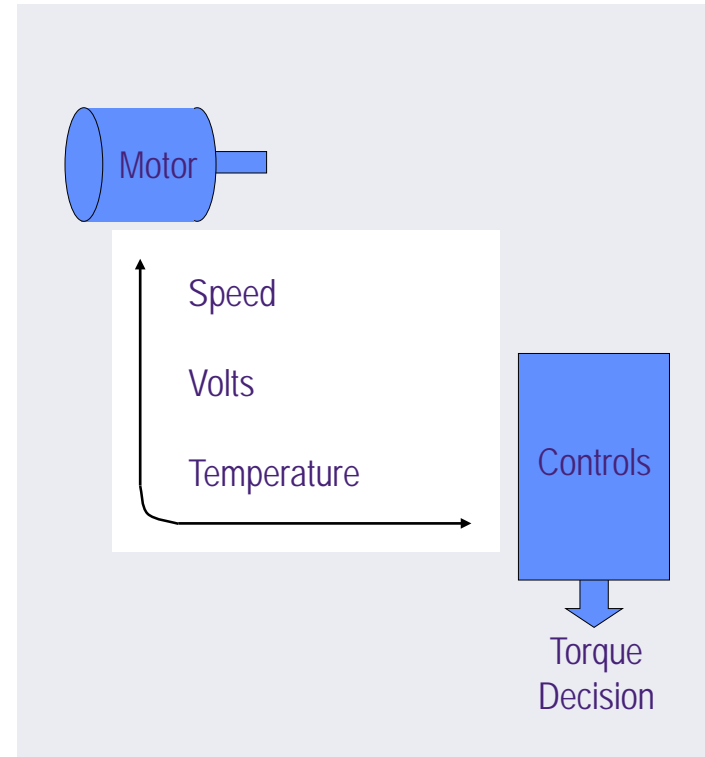



MX gear drive and manual override mechanism is designed for long-term performance

- ◆ High-strength rolled steel worm & bronze worm gear
- ◆ Lubricated with long-life synthetic oil designed specifically for gear service and extended temperature ranges
- ◆ The robust gear housing and support bearings provide for high efficiencies and long gear life
- ◆ Low declutch forces for manual override
- ◆ Optional side-handwheels for reduced effort on handwheel

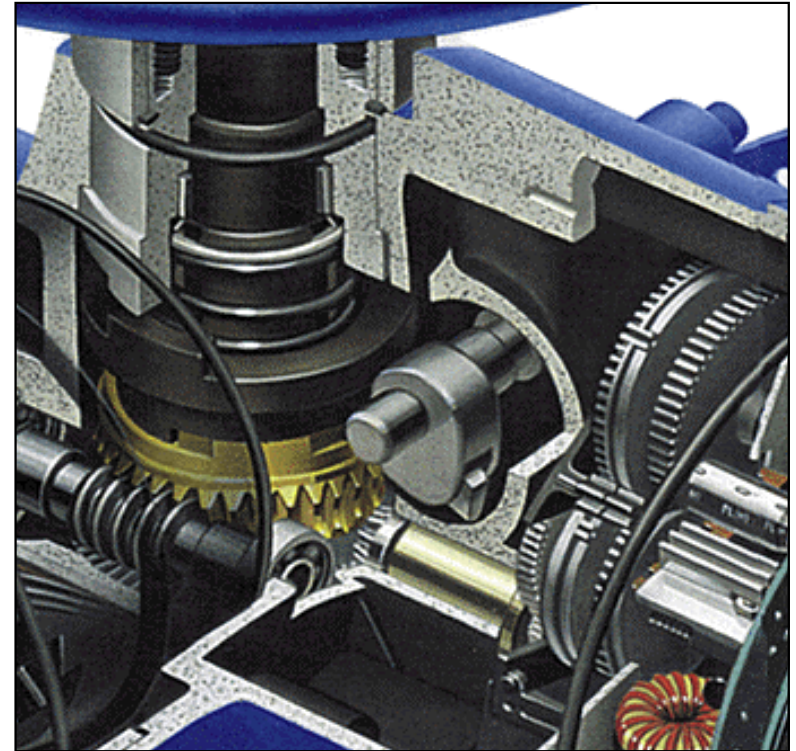



Local control panel simplifies installation, operation & maintenance.



- ◆ 32-character LCD display is easy to read and understand with graphics capability
- ◆ Display supports 10 languages
- ◆ Fast, non-intrusive set up, without tools
OPEN (YES)/CLOSE (NO) Black Switch
LOCAL/STOP/REMOTE Red Switch
- ◆ 4 LED's, Red/Green (reversible), Amber Monitor relay & Blue Bluetooth indicator
- ◆ Optional status power backup (LCD & AS)
- ◆ Infrared port for software & diagnostics
- ◆ Control panel can be rotated in 90° steps
- ◆ Password & padlock security



QX- Compact Design Part Turn Actuator

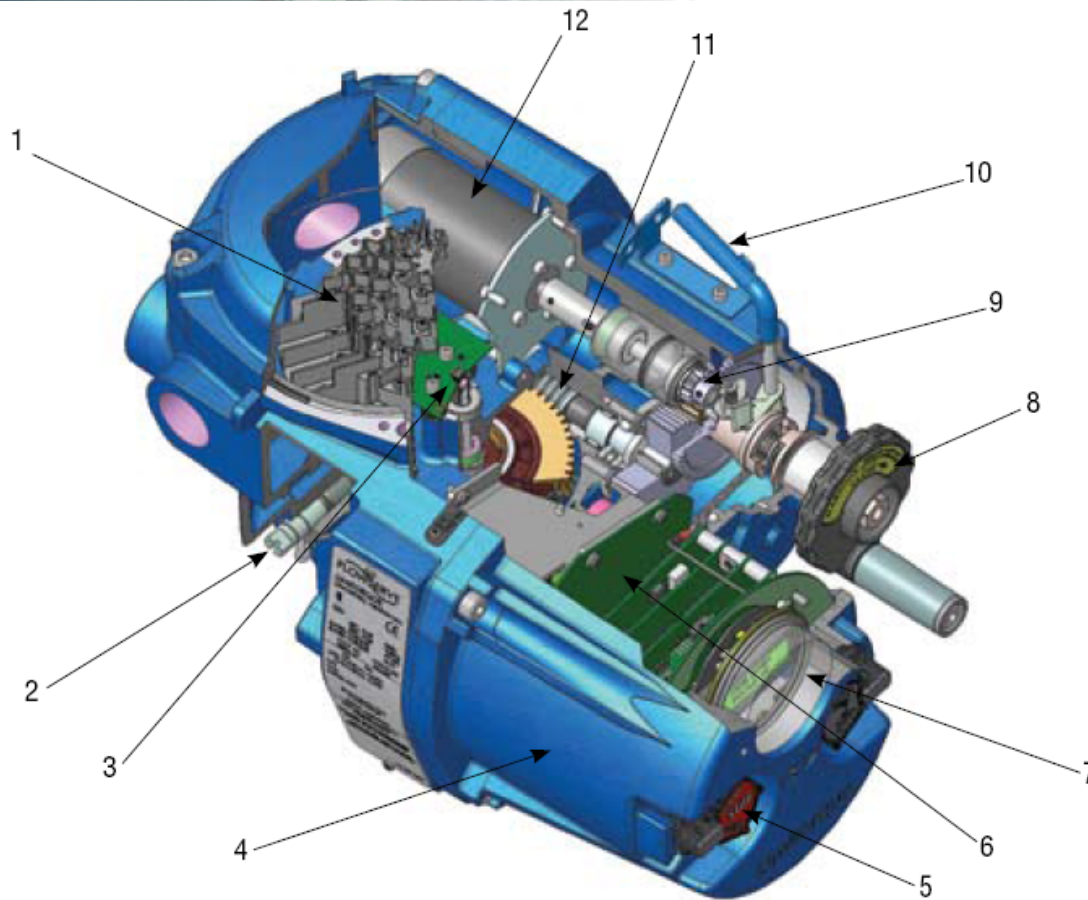

No.	Description
1	Terminal Chamber
2	Drive Sleeve Stop
3	Absolute Encoder
4	Cast Aluminum Housing
5	Local Control Switches
6	Control Chamber
7	LCD Multi-lingual Display
8	Handwheel
9	Motor Gear Attachment
10	Declutch Lever
11	Worm Gear Set
12	Brushless DC Motor



QX/QXM Actuator



- Absolute encoder – resolution to 0.1%
- Brushless DC Motor
- Bluetooth communications to 10M w/ Dashboard
- QX_Quik – up to 8 hrs. of reserve power to update the contact status & view LCD
- QX-1 thru 5 Quarter turn w/ torque to 1500 lb.ft.
- QXM up to 20 output turns
- Hall effect devices in lieu of reed switches
- IP68 to 15m for 96 hrs.
- Configurable digital inputs – ESD, Inhibits, User defined
- Torque sensing method – no moving parts
- Adjustable cycle speed for QX models.
- Solid State motor control .
- Open / Close or Modulation service.
- Suitable for 1200 Motor starts per hour.



Actuator Setup & Main Menu Selections

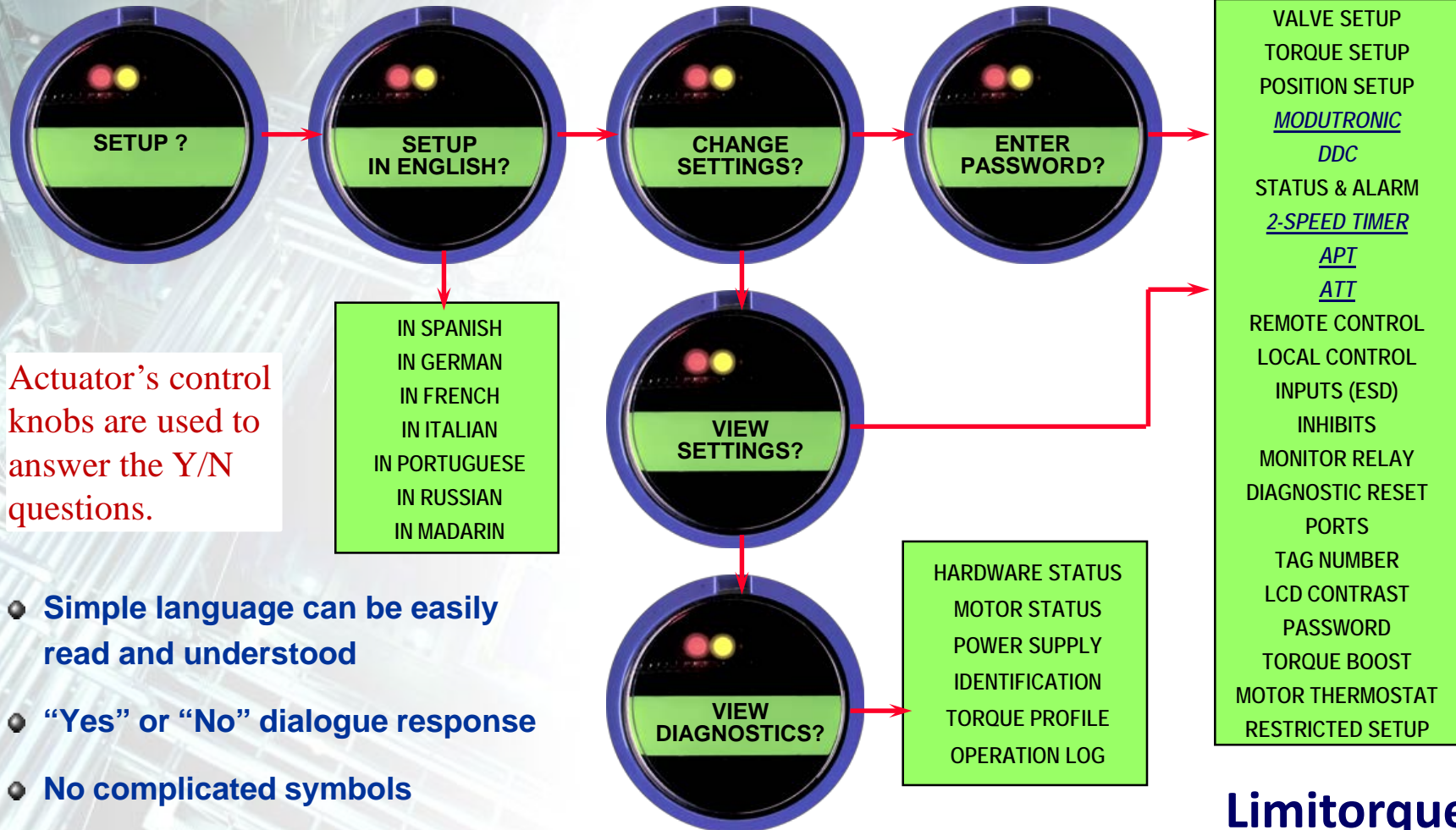

Actuator's control knobs are used to answer the Y/N questions.

- Simple language can be easily read and understood
- “Yes” or “No” dialogue response
- No complicated symbols



Status Contacts

- ◆ Configurable as N/O, N/C or Blinker type of contact
- ◆ Individually configurable - see list of functions opposite
- ◆ Standard – Two-pairs latched contacts for status feedback:
Default use: Open position - 1 x N/O, 1 x N/C
Close position - 1 x N/O, 1 x N/C
- ◆ Optional – Up to eight additional latching contacts for feedback can be added depending on current ratings.

Programmable for status and alarms:

Default use: Motor Overtemp [N/O], Remote Selected [N/O], Overtorque [N/C]

Monitor Relay

- ◆ Indicates actuator not available for remote control
- ◆ 1 x N/O & 1 x N/C contacts
- ◆ Tripped by: Power Off, Valve Jammed, Selector Switch in Local or Stop, Loss of Phase, Motor Overtemp

24 Functions Available:

- Closed
- Open
- Mid-travel
- Closing
- Opening
- Stopped
- Valve moving
- Local selected
- Motor overtemp
- Overtorque
- Valve jammed
- Handwheel operated
- Close torque switch
- Open torque switch
- Local Stop/Off
- Lost phase
- ESD signal
- Close inhibit
- Open inhibit
- No analog signal
- Remote selected
- LimiGard
- Hardware failure
- Network controlled



MX – Bluetooth with Dashboard

The MX now offers Bluetooth technology as optional, up to 10 meters. When used with FlowsERVE Limatorque's Windows CE based graphical software interface Dashboard™, diagnostic information can be transferred easily to a PDA with Windows Mobile 5 platform, laptop computer or smart cell phone. In addition, new firmware can be uploaded and actuator configurations transferred from one device to any number of subsequent actuators.



Standard low power wireless communication path to the actuator enables monitoring and configuration of the unit up to 10m in any direction via a Bluetooth equipped PC, PDA, smart cell phone, etc. FHSS (Frequency Hopping Spread Spectrum) allows a reliable communication link even in a "noisy" environment and 128 bit data encryption can be enabled to protect the privacy of the link. MX Dashboard configuration / diagnostics tools can use the Bluetooth link as a means for communicating with the actuator. A visible blue LED in the controls LCD window on the face of the actuator signifies an active Bluetooth link to the actuator has been established.



Protection features for actuators & valves



- ◆ Autophase correction & lost phase protection
- ◆ Jammed valve protection, with single automatic reverse/forward motion to free a stuck valve from closed position
- ◆ Instantaneous reversal protection reduces surges in current and prolongs contactor life
- ◆ Solid state thermistor protects motor from thermal overload
- ◆ Minimal circuit boards and electronic components
- ◆ LimiGard™ circuit - patented



Accutronix offers complete flexibility for the remote control of valves

- **Discrete Hardwired Control**

2-wire, 3-wire, 4-wire

- **Modutronic Controller**

4-20 mA signal

- **DDC-100 Digital Network**

Foundation Fieldbus H1

Profibus DP-V1, PA

Modbus™ up to 19.2k

DeviceNet

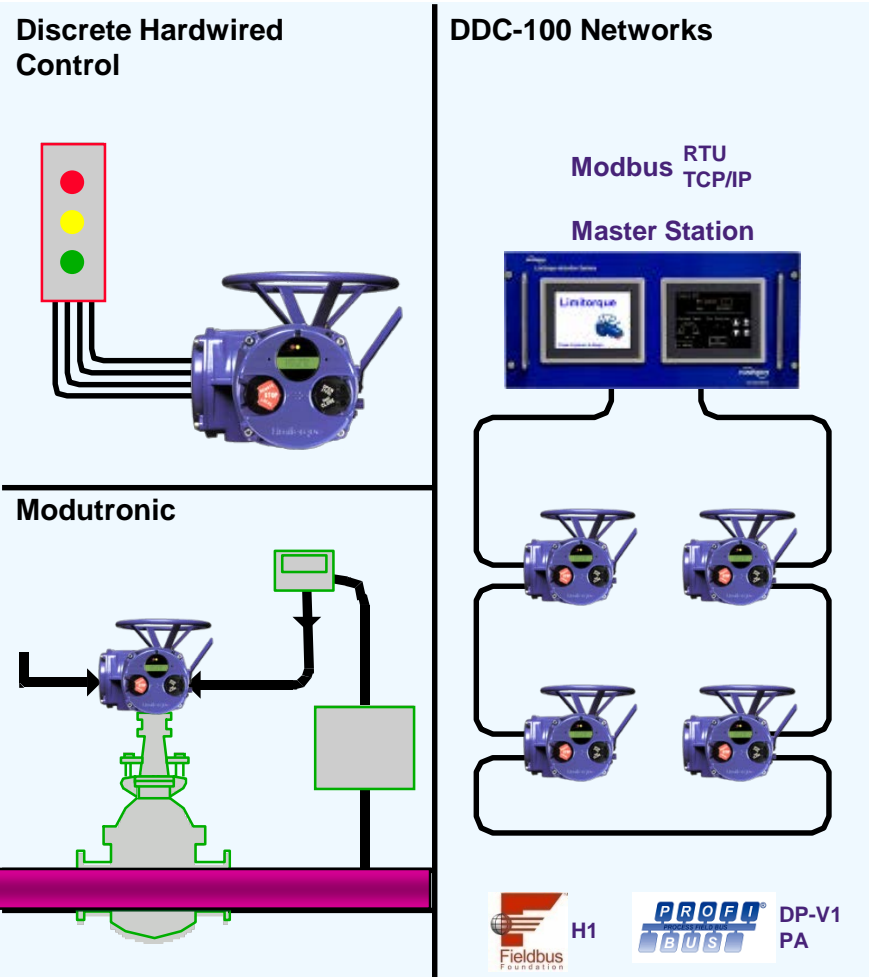



Modutronic Controller

- ◆ Proportional control by 4-20mA signal
- ◆ Repeatable encoder-based, high resolution positioning
- ◆ Adjustable deadband, gain (proportional band), and fail position on loss of signal
- ◆ Non-contacting position feedback
- ◆ Simplified setup through the control panel

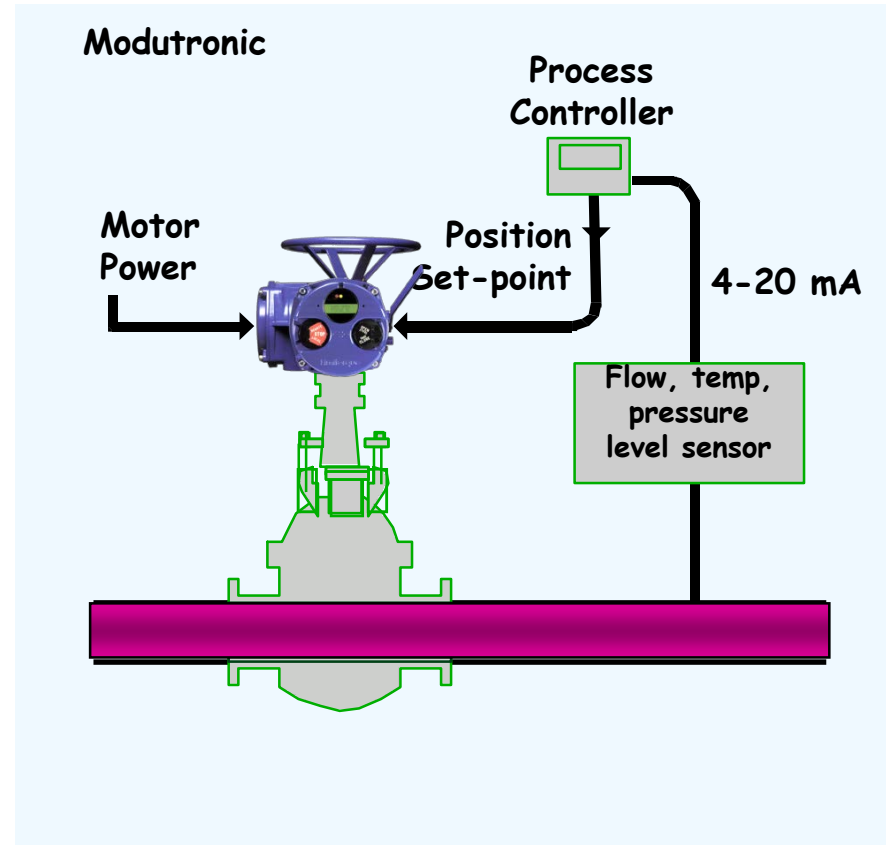



Network Protocols

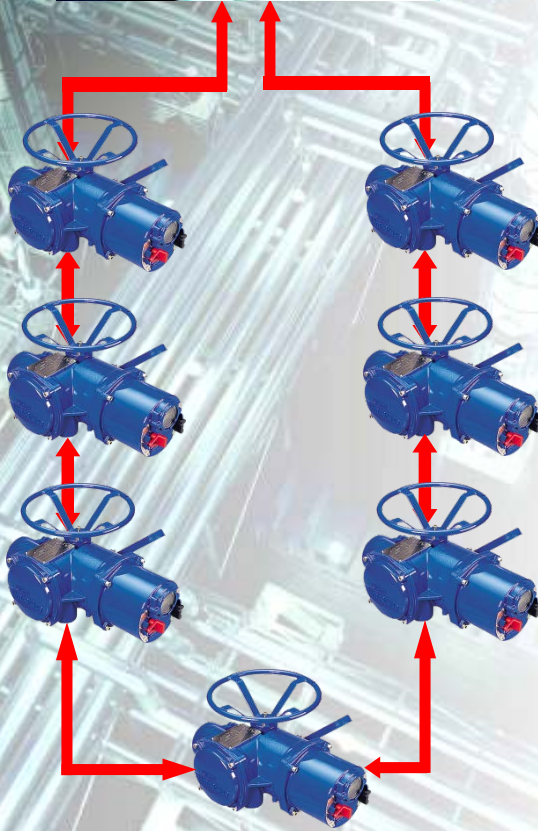

Modbus RTU & TCP/IP Ethernet

Current industry standard for medium speed networks worldwide. Loop network.



PA DP-V1 Redcom - Dual multidrop

Current industry standard for medium speed networks mainly in central Europe, becoming more widely used. Multi-drop / Dual Multi-drop.



H1

Latest network protocol mainly used for high speed process, few installed sites. Multi-drop / Dual Multi-drop.

DeviceNet

Industry standard used by Allen Bradley.



MX/QX Options



- ◆ 4-20mA Analog Position Transmitter - APT
- ◆ 4-20mA Analog Torque Transmitter - ATT
- ◆ Solid State Motor Reverser – 1200 starts per hour
- ◆ Remote Control Station (CSE)
- ◆ Negative Switching
- ◆ MX Quik

The ability to withstand short term power outages.

Powers relays and display during handwheel Operation

Low power 'Sleep' mode to prolong power outage withstand capabilities



Accutronix has been rigorously tested in the lab and in the field for performance and endurance



- ◆ **Vibration and Seismic resistance to IEC68-2-6 & MIL-STD-167**
- ◆ **Temperature/humidity extremes**
 - **Standard: -30°C to +65°C**
 - **Temperature rise: +85°C**
 - **Special Temperature: -55°C to +50°C**
- ◆ **Electro-magnetic interference (EMI)**
- ◆ **Conducted and radiated emissions - EN55011**
- ◆ **'CE' Stamped - E.C. Directive 89/392/EEC**
- ◆ **Corrosion resistance (including 1500hr salt spray)**
- ◆ **Enclosure certification**
- ◆ **30 minute class H motors**



Enclosure testing & approvals

- **Certification:**

- FM/CSA – Nema 3, 4 & 6

- CENELEC – IP67, IP68* (IEC-529)

- FM – I, B, C & D, 1 & 2 and II, E, F & G

- ATEX – EExd IIB, IIC & EExde IIC and IIB

- CSA – I, C & D, 1 & 2 and II, E, F & G

- SAA – EExd IIB, IIC & EExde IIC and IIB

- INMETRO – (Brazil)

- GOST & GOST-R – (Russia)

- SLEV – (Ukraine)

- FTZU – (Czech Republic)

- BKI – (Hungary)

- *IP68 = 15m for 96 hrs

- **EU Directives:**

- EMC – Electromagnetic Compatibility

- LVD – Low Voltage Directive

