

CHAPTER TWO

**The Data of
Macroeconomics**

macroeconomics
6th edition

N. Gregory Mankiw

macro

Learning objectives

In this chapter, you will learn about:

- Gross Domestic Product (GDP)
- the Consumer Price Index (CPI)
- the Unemployment Rate

Gross Domestic Product

Two definitions:

1. Total expenditure on domestically-produced final goods and services
2. Total income earned by domestically-located factors of production

Why expenditure = income

In every transaction,
the buyer's expenditure
becomes the seller's income.

Thus, the sum of all
expenditure equals
the sum of all income.

The Circular Flow

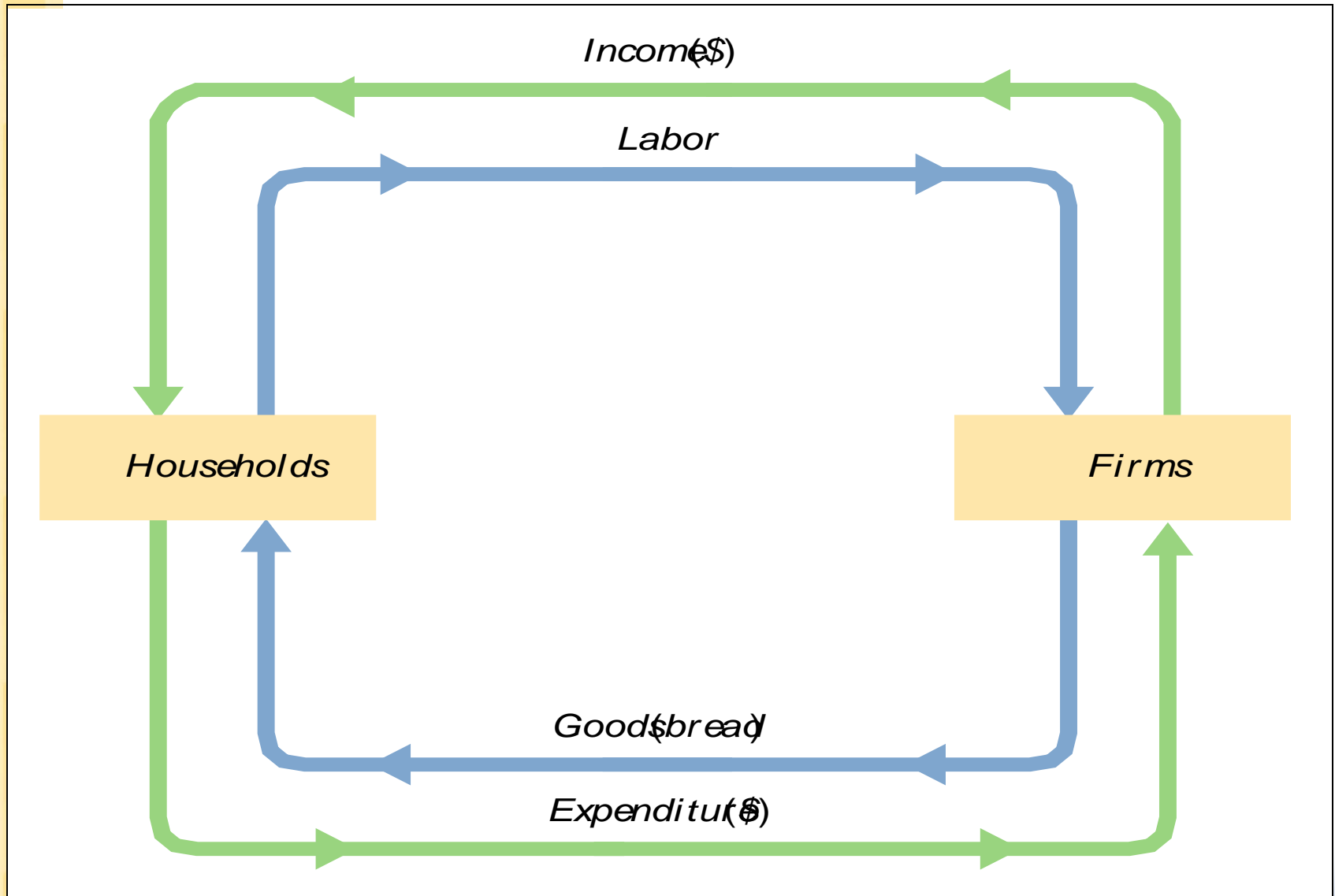

Value added

definition:

A firm's **value added** is
the value of its output
minus
the value of the intermediate goods
the firm used to produce that output.

Exercise: *(Problem 2)*

- A farmer grows a bushel of wheat and sells it to a miller for \$1.00.
- The miller turns the wheat into flour and sells it to a baker for \$3.00.
- The baker uses the flour to make a loaf of bread and sells it to an engineer for \$6.00.
- The engineer eats the bread.

Compute

- *value added at each stage of production*
- *GDP*

Final goods, value added, and GDP

- GDP = value of final goods produced
= sum of value added at all stages
of production
- The value of the final goods already includes the value of the intermediate goods, so including intermediate goods in GDP would be double-counting.

The expenditure components of GDP

- consumption
- investment
- government spending
- net exports

Consumption (C)

def: the value of all goods and services bought by households. Includes:



- ***durable goods***
last a long time
ex: cars, home appliances
- ***non-durable goods***
last a short time
ex: food, clothing
- ***services***
work done for consumers
ex: dry cleaning, air travel.

U.S. Consumption, 2016

	\$ billions	% of GDP
Consumption	\$12,820.7	68.8%
Durables	1,441.0	7.7
Nondurables	2,710.4	14.6
Services	8,699.3	46.7

Investment (I)

def1: spending on [the factor of production] capital.

def2: spending on goods bought for future use.

Includes:

- ***business fixed investment***
spending on plant and equipment that firms will use to produce other goods & services
- ***residential fixed investment***
spending on housing units by consumers and landlords
- ***inventory investment***
the change in the value of all firms' inventories

U.S. Investment, 2016

	\$ billions	% of GDP
Investment	\$3,057.2	16.4%
Business fixed	2,316.2	12.4
Residential fixed	705.9	3.8
Inventory	35.1	0.2

Investment vs. Capital

- Capital is one of the factors of production. At any given moment, the economy has a certain overall stock of capital.
- Investment is spending on new capital.

Investment vs. Capital

Example (*assumes no depreciation*):

- 1/1/2016:
economy has \$500b worth of capital
- during 2016:
investment = \$37b
- 1/1/2017:
economy will have \$537b worth of capital

Stocks vs. Flows

A **stock** is a quantity measured at a point in time.

We might say
“the U.S. capital stock
was \$25.4 trillion as of
December 31, 2003.”

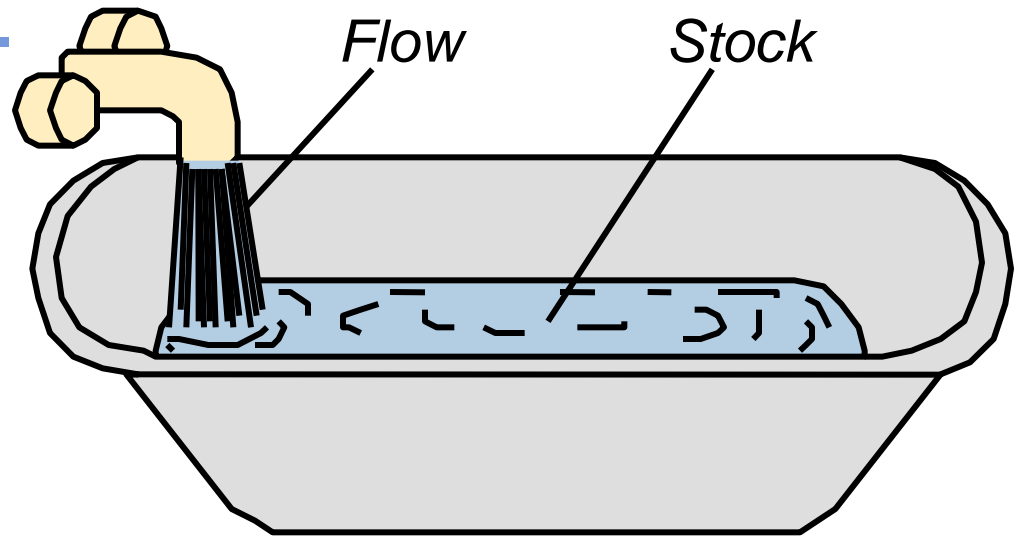

A **flow** is a quantity measured per unit time.

“U.S. investment was \$2 trillion in 2003.”

Stocks vs. Flows - examples

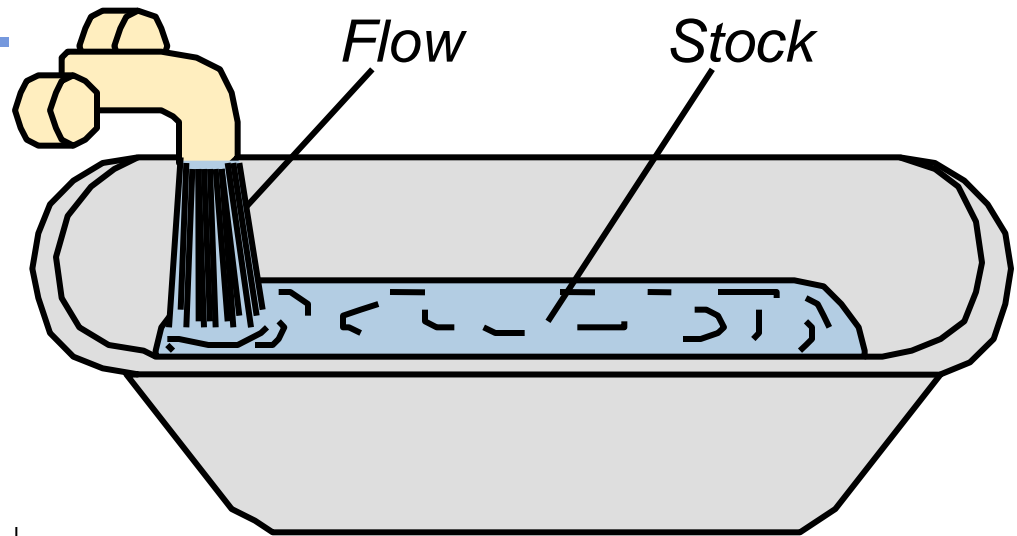

<i>stock</i>	<i>flow</i>
a person's wealth	a person's annual saving
# of people with college degrees	# of new college graduates
the govt. debt	the govt. budget deficit

Now you try:

Stock or flow?

The balance on your bank account.

How much you study economics outside of class.

The size of your compact disc collection.

The inflation rate.

The unemployment rate.

Government spending (G)

- **G** includes all government spending on goods and services.
- **G** excludes transfer payments (e.g. unemployment benefits payments), because they do not represent spending on goods and services.

Government spending, 2016

	\$ billions	% of GDP
Gov spending	\$3,267.8	17.5%
Federal	1,231.5	6.6
Non-defense	502.6	2.7
Defense	728.9	3.9
State & local	2,036.3	10.9

Net exports ($NX = EX - IM$)

def: the value of total exports (**EX**)
minus the value of total imports (**IM**)

US net exports, 1970 - 2017

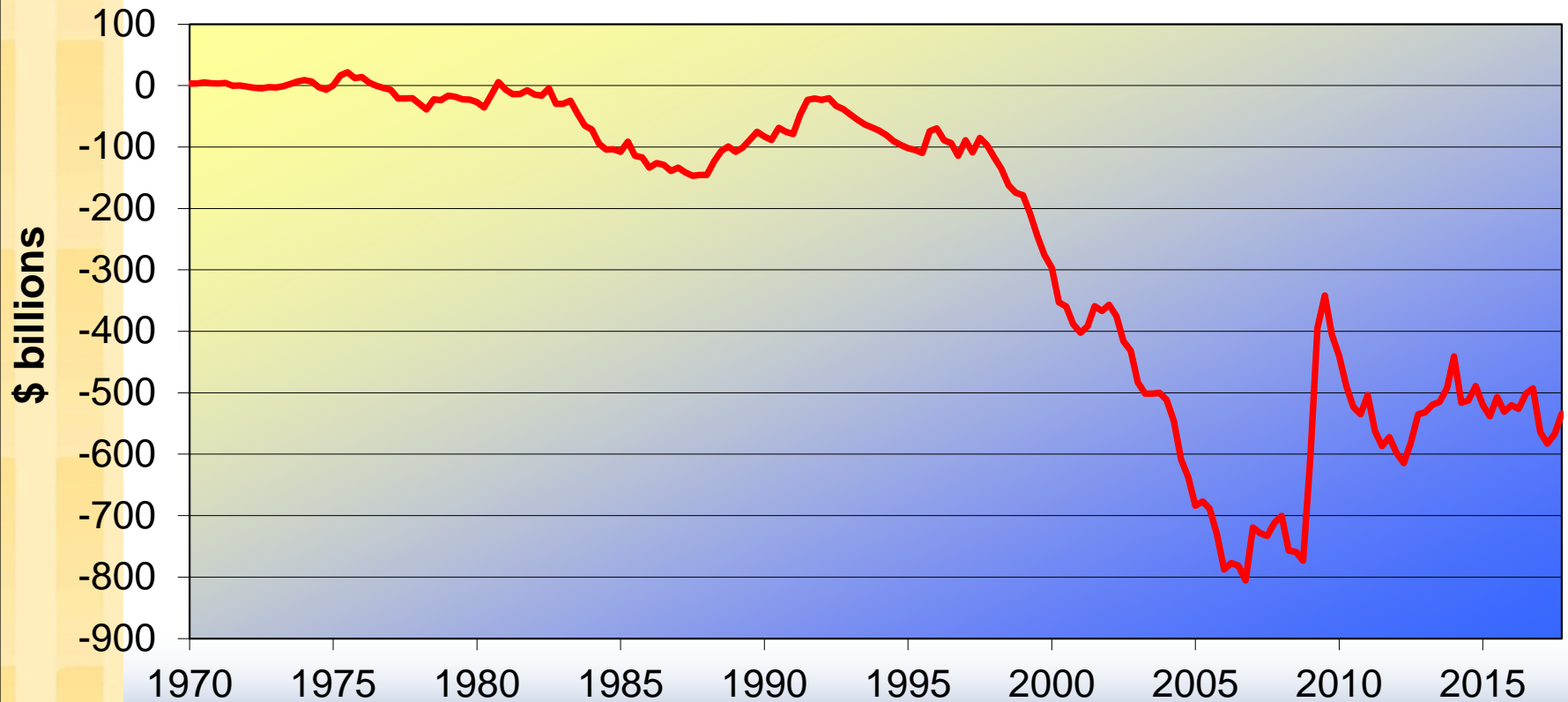

An important identity

$$Y = C + I + G + NX$$

where

Y = GDP = the value of final output

C + I + G + NX = aggregate expenditure

A question for you:

Suppose a firm

- produces \$10 million worth of final goods
- but only sells \$9 million worth.

Does this violate the
expenditure = output identity?

Why output = expenditure

- Unsold output goes into inventory, and is counted as “inventory investment”...
...whether the inventory buildup was intentional or not.
- In effect, we are assuming that firms purchase their unsold output.

GDP:

An important and versatile concept

We have now seen that GDP measures

- total income
- total output
- total expenditure
- the sum of value-added at all stages in the production of final goods

GNI vs. GDP

- **Gross National Income (GNI):**
total income earned by the nation's factors of production, regardless of where located
- **Gross Domestic Product (GDP):**
total income earned by domestically-located factors of production, regardless of nationality.

$$(GNI - GDP) = (\text{factor payments from abroad}) \\ - (\text{factor payments to abroad})$$

Discussion Question:

In your country,
which would you want
to be bigger, GDP or GNI?

Why?

(GNI – GDP) as a percentage of GDP

selected countries, 2002

U.S.A.	1.0%
Angola	-13.6
Brazil	-4.0
Canada	-1.9
Hong Kong	2.2
Kazakhstan	-4.2
Kuwait	9.5
Mexico	-1.9
Philippines	6.7
U.K.	1.6

Real vs. Nominal GDP

- GDP is the value of all final goods and services produced.
- **Nominal GDP** measures these values using current prices.
- **Real GDP** measure these values using the prices of a base year.

Real GDP controls for inflation

Changes in nominal GDP can be due to:

- changes in prices
- changes in quantities of output produced

Changes in real GDP can only be due to changes in quantities, because real GDP is constructed using constant base-year prices.

Practice problem, part 1

	2015		2016		2017	
	P	Q	P	Q	P	Q
good A	\$30	900	\$31	1,000	\$36	1,050
good B	\$100	192	\$102	200	\$100	205

- Compute nominal GDP in each year
- Compute real GDP in each year using 2014 as the base year.

U.S. Real & Nominal GDP, 1970-2017

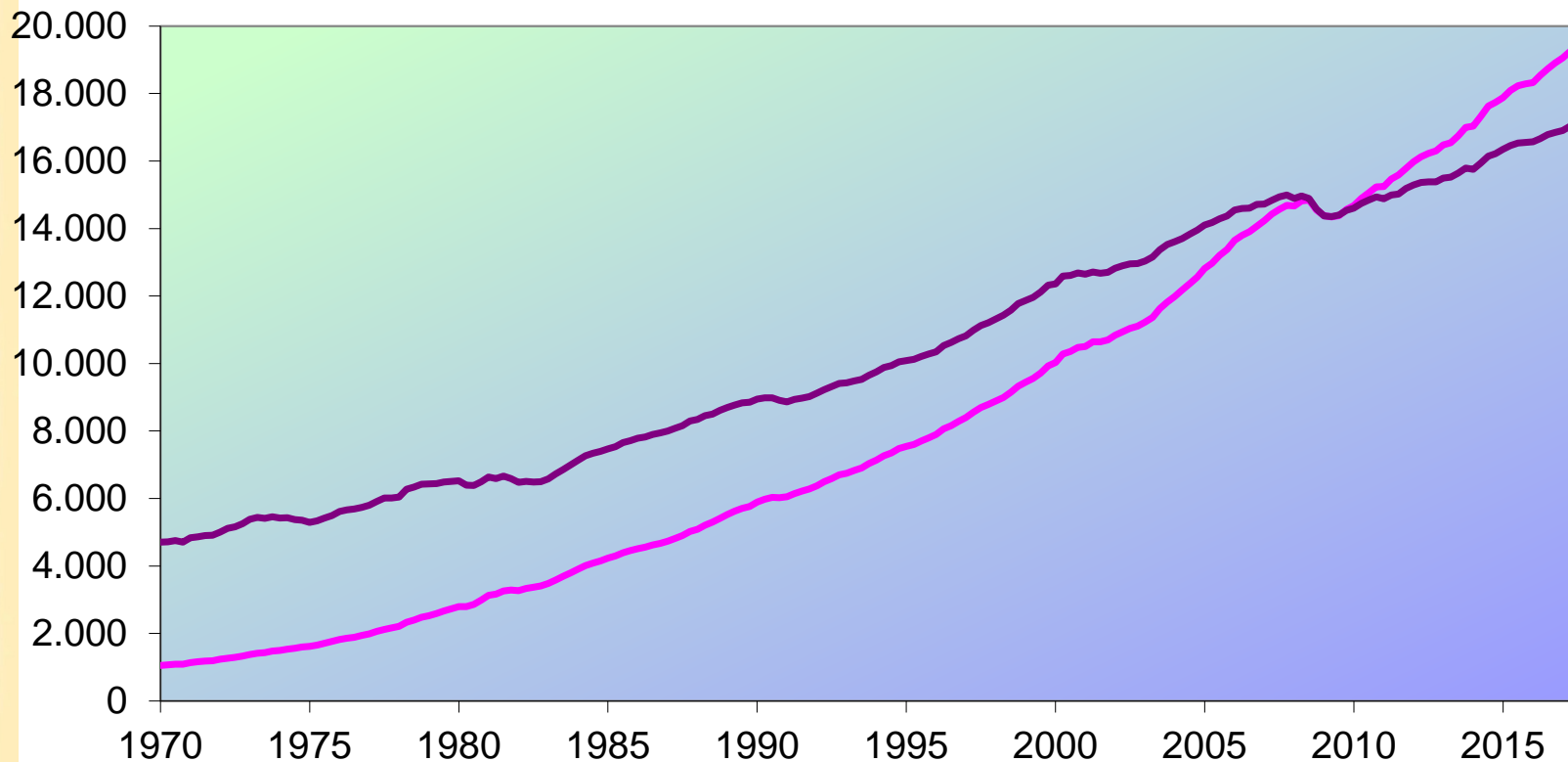

— Nominal GDP (billions of dollars)

— Real GDP (billions of chained 2009 dollars)

GDP Deflator

- The **inflation rate** is the percentage increase in the overall level of prices.
- One measure of the price level is the **GDP Deflator**, defined as

$$\text{GDP deflator} = 100 \times \frac{\text{Nominal GDP}}{\text{Real GDP}}$$

Practice problem, part 2

	Nom. GDP	Real GDP	GDP deflator	inflation rate
2015	\$46,200	\$46,200		<i>n.a.</i>
2016	51,400	50,000		
2017	58,300	52,000		

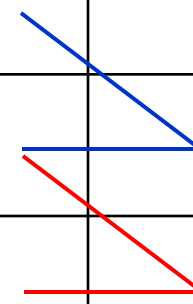

- Use your previous answers to compute the GDP deflator in each year.
- Use GDP deflator to compute the inflation rate from 2015 to 2016, and from 2016 to 2017.

Working with percentage changes

USEFUL TRICK #1 For any variables X and Y ,
the percentage change in $(X \times Y)$
 \approx the percentage change in X
+ the percentage change in Y

EX: If your hourly wage rises 5%
and you work 7% more hours,
then your wage income rises approximately 12%.

Working with percentage changes

USEFUL TRICK #2

the percentage change in (X/Y)
 \approx the percentage change in X
– the percentage change in Y

EX: GDP deflator = $100 \times \text{NGDP}/\text{RGDP}$.

If NGDP rises 9% and RGDP rises 4%,
then the inflation rate is approximately 5%.

Chain-weighted Real GDP

- Over time, relative prices change, so the base year should be updated periodically.
- In essence, “chain-weighted Real GDP” updates the base year every year.
- This makes chain-weighted GDP more accurate than constant-price GDP.
- But the two measures are highly correlated, and constant-price real GDP is easier to compute...
- ...so we'll usually use constant-price real GDP.

Chain-weighted Real GDP

Entwicklung des realen Bruttoinlandsprodukts in den USA
im Zeitraum 1982 bis 1994

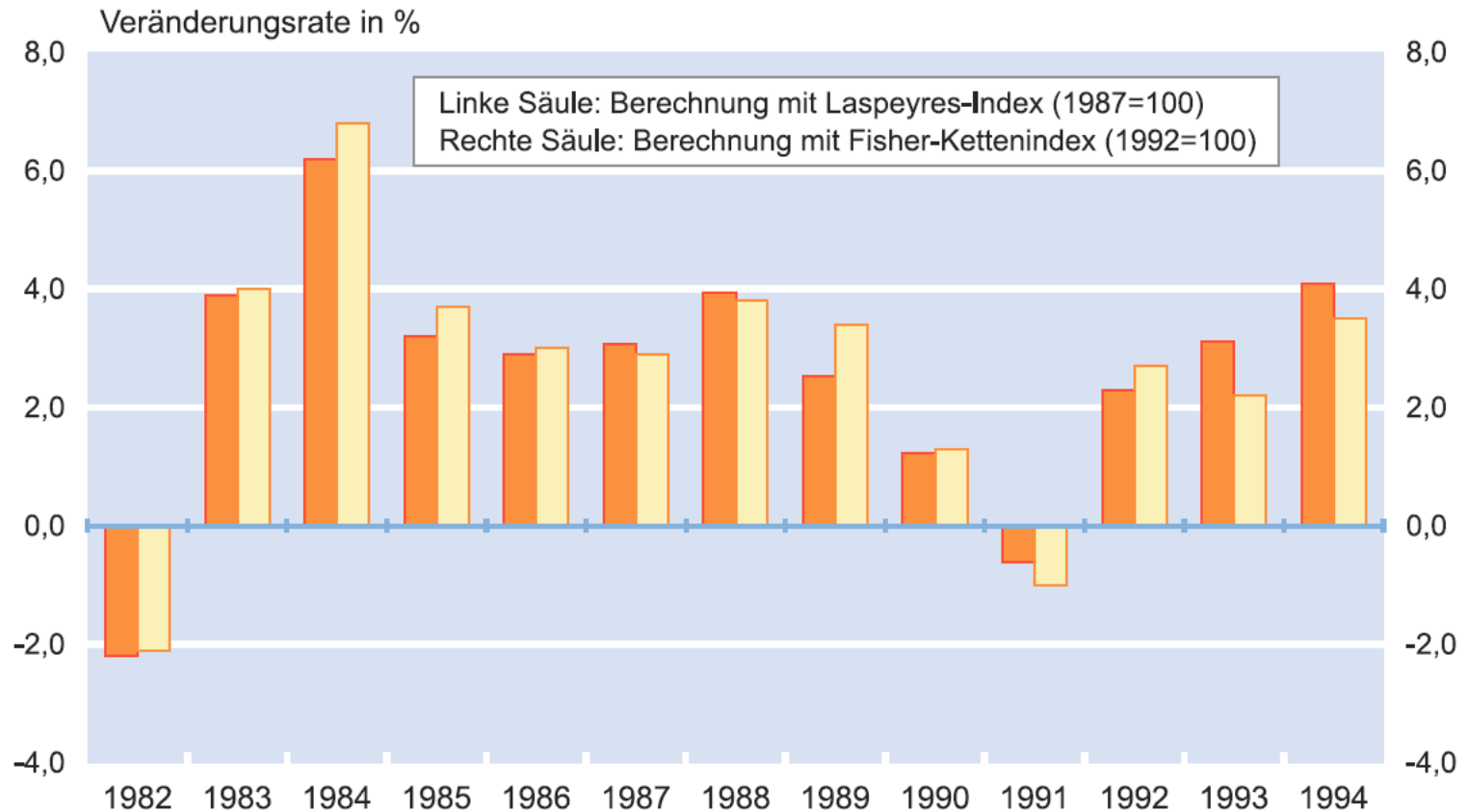

Quelle: Bureau of Economic Analysis (BEA).

GDP AND ECONOMIC WELL-BEING

- GDP is the best single measure of the economic well-being of a society.
- GDP per person tells us the mean income and expenditure of the people in the economy.

GDP AND ECONOMIC WELL-BEING

- Higher GDP per person indicates a higher standard of living.
- GDP is not a perfect measure of the happiness or quality of life, however.

GDP AND ECONOMIC WELL-BEING

- Some things that contribute to well-being are not included in GDP.
 - The value of leisure.
 - The value of a clean environment.
 - The value of almost all activity that takes place outside of markets, such as the value of the time parents spend with their children and the value of volunteer work.

Consumer Price Index (CPI)

- A measure of the overall level of prices
- Published by the **Bureau of Labor Statistics (BLS)**
- Used to
 - track changes in the typical household's cost of living
 - adjust many contracts for **inflation** (*i.e.* "COLAs")
 - allow comparisons of dollar figures from different years

How the BLS constructs the CPI

1. Survey consumers to determine composition of the typical consumer's "basket" of goods.
2. Every month, collect data on prices of all items in the basket; compute cost of basket
3. CPI in any month equals

$$100 \times \frac{\text{Cost of basket in that month}}{\text{Cost of basket in base period}}$$

Exercise: *Compute the CPI*

The basket contains 20 pizzas and 10 compact discs.

prices:

	pizza	CDs
2014	\$10	\$15
2015	\$11	\$15
2016	\$12	\$16
2017	\$13	\$15

- For each year, compute
- the cost of the basket
 - the CPI (use 2014 as the base year)
 - the inflation rate from the preceding year

The composition of the CPI's "basket"

(2013-14 expenditure weights)

■ Food and bev.

■ Housing

■ Apparel

■ Transportation

■ Medical care

■ Recreation

■ Education

■ Communication

■ Other goods and services

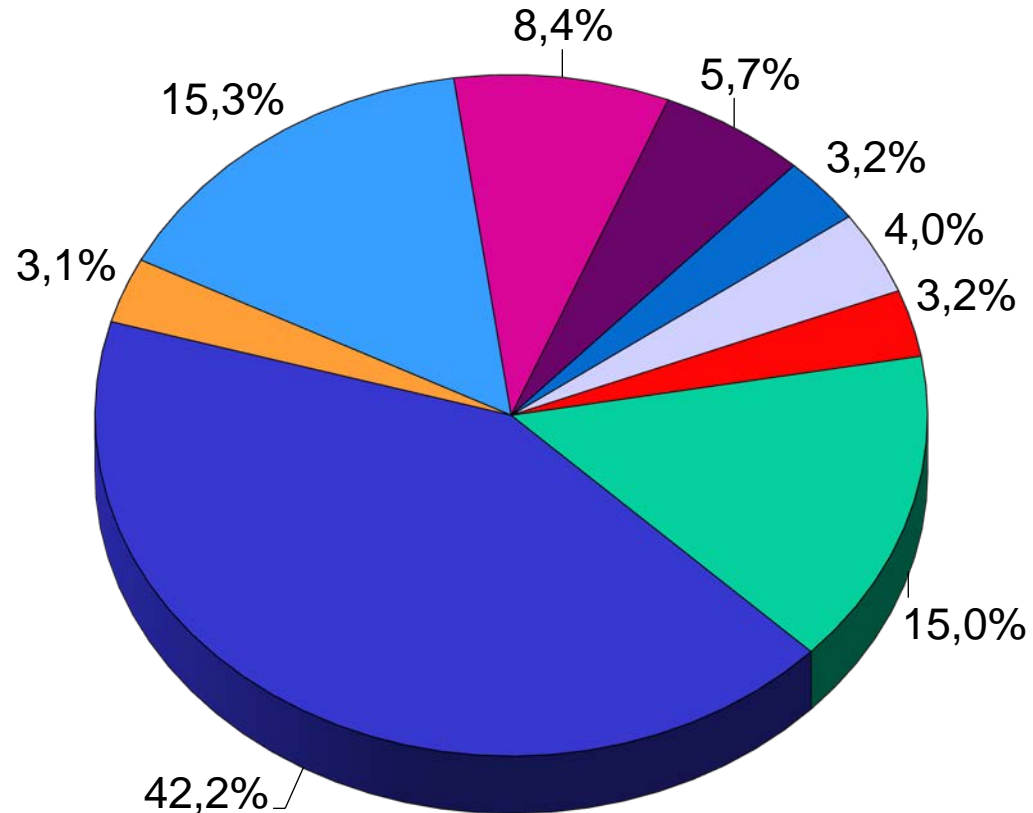

Problems in Measuring the Cost of Living

- The CPI is an accurate measure of the price development of selected goods that make up the typical bundle, but it is not a perfect measure of the **cost of living**.

Reasons why the CPI may overstate inflation

- **Substitution bias:** The CPI uses fixed weights, so it cannot reflect consumers' ability to substitute toward goods whose relative prices have fallen.
- **Introduction of new goods:** The introduction of new goods makes consumers better off and, in effect, increases the real value of the dollar. But it does not reduce the CPI, because the CPI uses fixed weights.
- **Unmeasured changes in quality:** Quality improvements increase the value of the dollar, but are often not fully measured.

The CPI's bias

- The Boskin Panel's "best estimate":
The CPI overstates the true increase in the cost of living by 1.1% per year.
- Result: the BLS has refined the way it calculates the CPI to reduce the bias.
- It is now believed that the CPI's bias is slightly less than 1% per year.

CPI vs. GDP deflator

prices of capital goods

- included in GDP deflator (if produced domestically)
- excluded from CPI

prices of imported consumer goods

- included in CPI
- excluded from GDP deflator

the basket of goods

- CPI: fixed
- GDP deflator: changes every year

Two measures of inflation

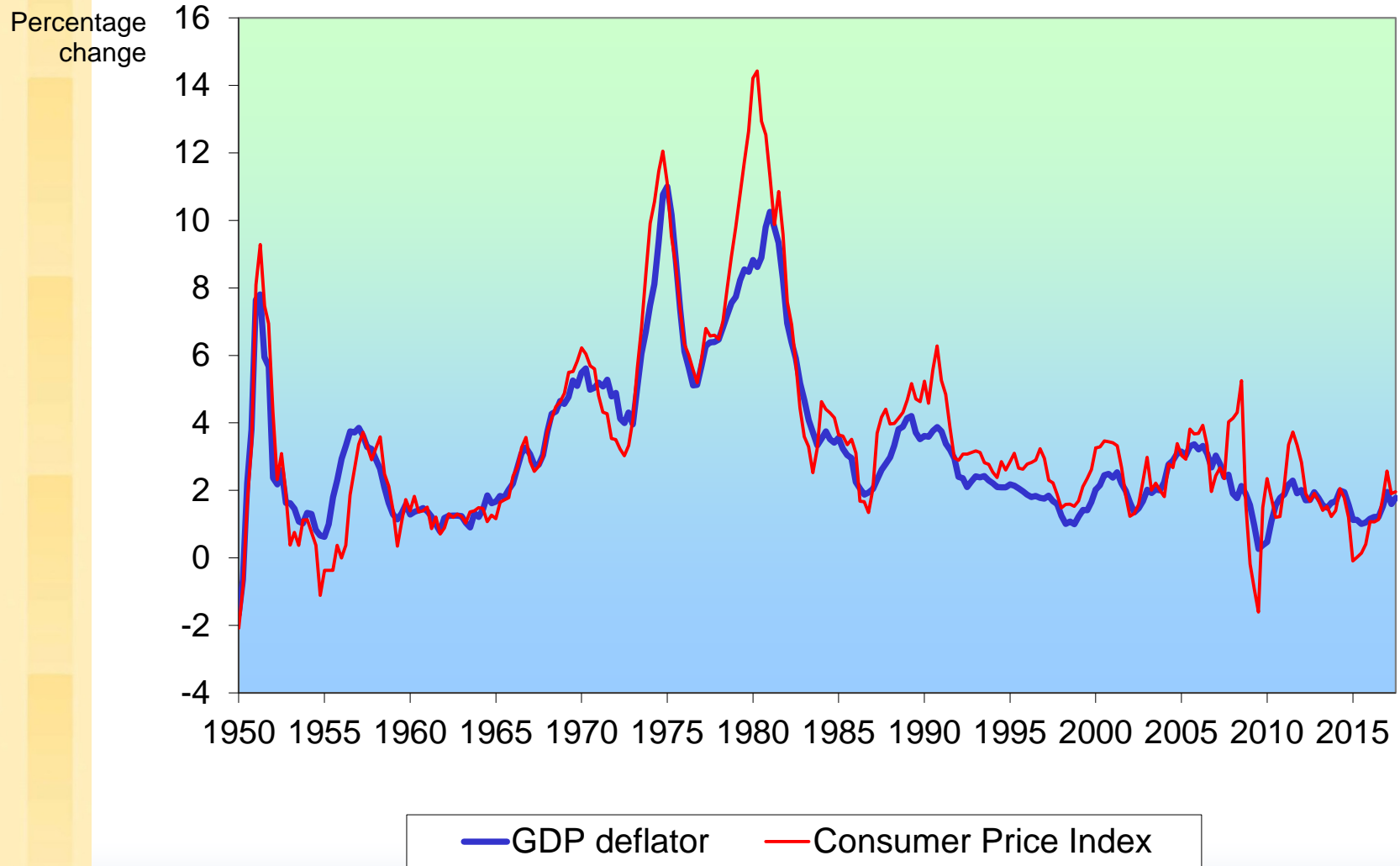

Categories of the population

- *employed*
working at a paid job
- *unemployed*
not employed but looking for a job
- *labor force*
the amount of labor available for producing goods and services; all employed plus unemployed persons
- *not in the labor force*
not employed, not looking for work.

Two important labor force concepts

- *unemployment rate*
percentage of the labor force that is unemployed
- *labor force participation rate*
the fraction of the adult population that 'participates' in the labor force

Exercise: *Compute labor force statistics*

U.S. adult population by group, Dec. 2017

Number employed	=	154.0 million
Number unemployed	=	6.6 million
Adult population	=	256.1 million

Use the above data to calculate

- the labor force
- the number of people not in the labor force
- the labor force participation rate
- the unemployment rate

Chapter Summary

1. Gross Domestic Product (GDP) measures both total income and total expenditure on the economy's final output of goods & services as well as the value of the latter.
2. Nominal GDP values output at current prices; real GDP values output at constant prices. Changes in output affect both measures, but changes in prices only affect nominal GDP.
3. GDP is the sum of consumption, investment, government purchases, and net exports.

Chapter Summary

4. The overall level of prices can be measured by either
 - the Consumer Price Index (CPI), the price of a fixed basket of goods purchased by the typical consumer
 - the GDP deflator, the ratio of nominal to real GDP
5. The unemployment rate is the fraction of the labor force that is not employed.

