

MANUAL OF APPLIED MACHINERY DESIGN

HERBERT H. ALVORD

Mechanical Engineering

University of Michigan

CONTENTS

I. INTRODUCTION

1. Machine Design Procedure
2. Things to be Considered
3. Construction of Machinery

II. SUPPORT AND RETAINMENT OF ROTATING MACHINE PARTS

4. Introduction
5. Basic Principles
6. Bearings and Auxiliary Parts
7. Ball Bearings
8. Straight Roller Bearings
9. Tapered Roller Bearings
10. Ball and Roller Thrust Bearings
11. Locknuts and Retainer Rings
12. Sliding Bearings
13. Oil and Grease Seals
14. Common Constructions
15. Overhung Mountings
16. Supporting One Shaft Inside Another Shaft
17. Dead Shaft Construction
18. Supporting Bevel Gears
19. Supporting Worm Gears
20. Number of Bearings on One Shaft

III. CLUTCHES

21. Introduction
22. Positive Acting Clutches
23. Friction Clutches
24. Friction Disk Clutch

- 25. Friction Cone Clutch
- 26. Clutch Operating Linkage
- 27. Power Actuated Clutches
- 28. Over-Running Clutches

IV. BRAKES

- 29. External Shoe Brakes
- 30. Internal Shoe Brakes
- 31. Band Brakes
- 32. Disk Brakes

V. SPEED AND DIRECTION CHANGING DEVICES

- 33. Gear Units
- 34. Friction Devices

VI. MOTION CHANGING DEVICES

- 35. Cams
- 36. Cranks and Eccentrics
- 37. Intermittent Motion Devices
- 38. Linkages

VII. DESIGN OF CASTINGS AND WELDMENTS

- 39. Casting Design
- 40. Welding Design

VIII. HOUSING DESIGN

- 41. One Piece and Multiple Piece Construction
- 42. Means of Fastening
- 43. Alignment of Pieces and Shape of Housing
- 44. Housing Openings and Caps
- 45. Supporting the Housing

CHAPTER I

INTRODUCTION

The designing of machinery often seems like some sort of mysterious "hocus-pocus" to the beginner. This is in part due to not knowing exactly how to go about the job of designing a machine, as well as to not being sure of just what things must be considered in the process of doing the design job. Furthermore, the beginner is generally handicapped by the lack of knowledge about how machines are constructed.

This book is written to help the beginning designer who finds him or herself in the situation described above. A good deal of grief can be avoided by carefully studying the following paragraphs and chapters. It will be noticed that all the information has to do with the practical aspects of design. The theory of machine design is well covered in textbooks, and so is not repeated here.

1. MACHINE DESIGN PROCEDURES

It is difficult if not impossible to lay down any set rules of procedure for designing machinery. The situations encountered are too varied to allow this. However, it is possible to point out a general procedure which will, in the majority of cases, prove to be helpful to the beginning designer. This general procedure can be stated briefly in the form of several steps as follows:

- a. Before starting work on the design of any machine, get thoroughly familiar with what the machine is intended to accomplish and what special requirements or limitations must be considered.
- b. Make free-hand sketches of various ways the machine might be constructed, at the same time making any preliminary calculations which might be required to substantiate your ideas or to establish approximate sizes.
- c. Having established what seems to be a feasible construction, make a layout drawing of the machine, paying particular attention to the necessary details of construction.
- d. Analyze the layout for forces, stresses, etc., and make whatever calculations are necessary to be certain that the parts will perform satisfactorily.
- e. Revise the layout drawing as necessary for the finished design.

The above steps involve a great deal of patient work. A good many constructions must generally be considered and discarded before arriving at what seems to be the most satisfactory design. The student designer will save himself time and effort if he bears in mind the following considerations while he works at the steps listed above:

- a. A designer thinks on the drawing board or sketch pad. It is impossible to visualize all the details of a machine without putting it down on paper.
- b. Sketches should be made large enough, and complete enough, to picture the construction of the machine, rather than merely showing a schematic plan of operation.
- c. Drawings should be made full scale whenever possible and should be as complete and detailed as possible. It is only by seeing the machine pictured in its true size and shape that the designer can make use of his own judgement.

2. THINGS TO BE CONSIDERED

While working on the procedure, the designer must be careful to consider every important factor which should rightfully influence his design. In general, the most important things to be considered can be listed as follows:

- a. proper functioning
- b. cost
- c. lubrication
- d. ease of manufacture and assembly
- e. strength and rigidity of parts
- f. wear of parts
- g. ease of service and replacing parts
- h. proportion of parts

It is immediately seen that many of the above considerations are inter-related. No attempt has been made to arrange the list in any order of importance, but there is little question that the first one, proper functioning of the finished machine, is the foremost consideration.

Proper functioning of the machine implies the ability to do the required job dependably and well. Hence it is essential that the machine be designed to incorporate the best possible construction and methods of operation so as to get all the quality possible into the machine. One of the secrets of success in machinery design is to give the machine user as much as you possibly can in the machine, rather than try to get by with the barest minimum.

The problem of cost is forever with the designer. Although listed separately above, cost is also involved in many of the other things listed. The designer must be careful not to be misled when considering cost, however, for costs depend upon many things. Reducing the initial cost by reducing the quality of the machine is false economy since the additional cost of repair and down time will more than offset the original saving.

Similarly, reducing first costs by use of inferior materials, only to scrap a large percentage of parts due to warping during heat treatment, for example, is again a false economy. Many a designer has also found to his sorrow that the money saved by making

the diameter of a shaft or pin $\frac{1}{4}$ " smaller than it should have been would not even begin to pay for the cost of replacing the part once the machine was in service.

On the other hand, excessive size does not mean excessive quality, but it does mean excessive cost. Furthermore, inertia forces increase with the size of the part, and in many machines this more than offsets any gain resulting from using large parts. In any case, the designer must exercise his judgement to keep costs down to a reasonable value without impairing the quality of the finished product.

Ease of manufacture and assembly is also necessary to keep costs down. In most cases today, the designer does not specify exactly how the piece is to be manufactured, particularly so far as machining is concerned. However, he must design the parts so the fabricating and machining can be accomplished as easily as reasonably possible.

Parts must always be strong enough to carry the load resulting from the operation of the machine. Because strength and rigidity often lend themselves to being calculated, the beginning designer often loses sight of the fact that in many machine parts, neither strength nor rigidity requirements determine the necessary size and shape. Many parts carry no loads at all but still must have sufficient size to allow easy manufacture and assembly.

In fact, the designer will soon find that in most machines, only relatively few parts lend themselves to strength and rigidity calculations, even though large loads are carried. In such a case, the designer must use his judgement to properly proportion those parts whose strength cannot be calculated. Poor proportioning almost always plagues the beginning designer.

Figure 1 shows two different constructions used to support a three inch diameter gear on a shaft and bearing. One construction was obviously designed for small loads and light service, while the other construction was intended for heavy duty and resulting large loads. Nevertheless, both constructions shown are satisfactory, since all of the parts in any one assembly are properly proportioned for the type of service intended.

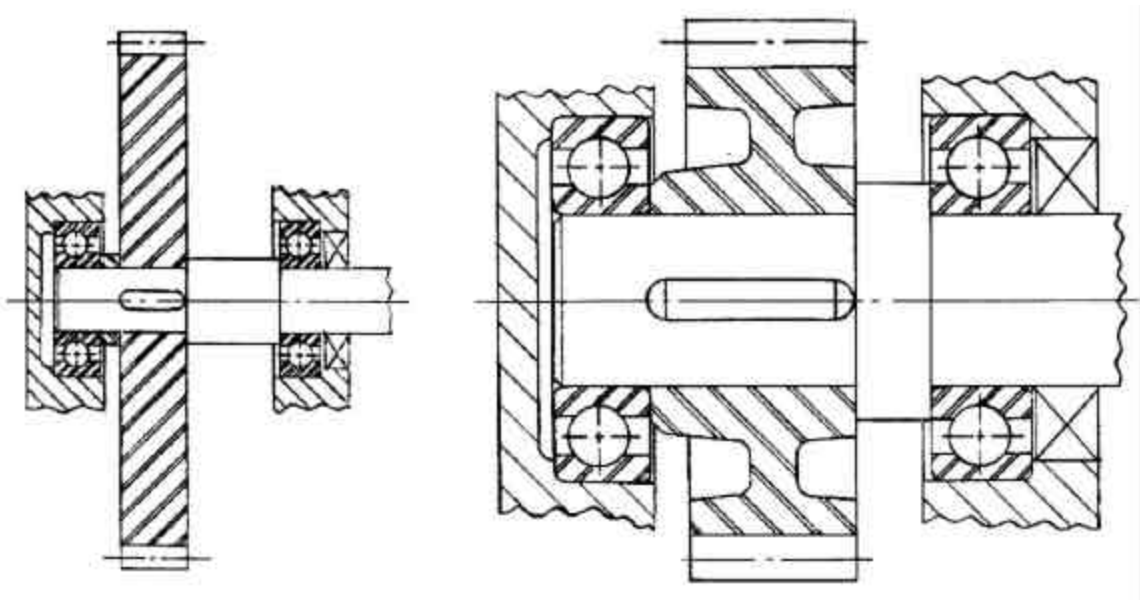

Figure 1

Figure 2 shows the gears again, but this time the proportions are not satisfactory. It is quite apparent that some parts are too large, while others are too small in the constructions shown. In other words, the proportioning is poor.

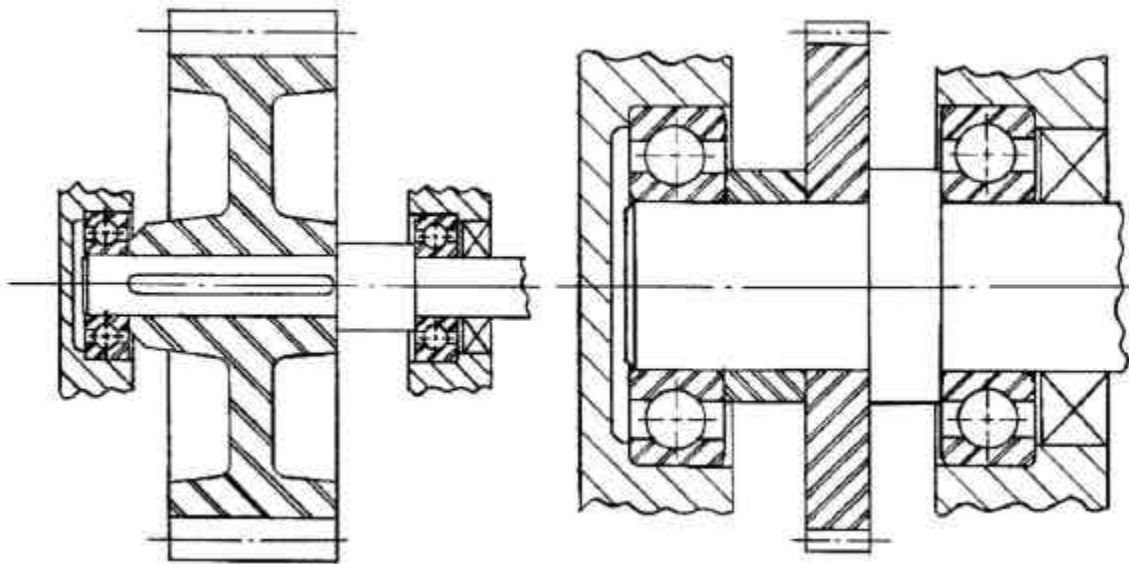

Figure 2

Figure 3 shows flange constructions, both well proportioned and poorly proportioned.

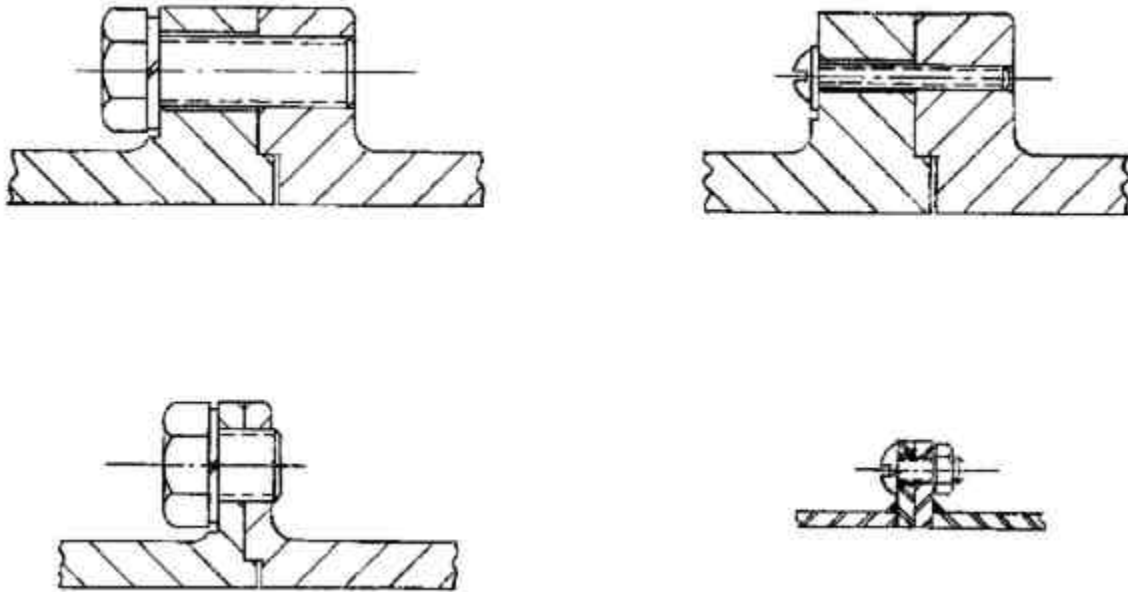

Figure 3

The ideas of good proportioning apply not only to the constructions shown here. This same idea should be applied to the design of each and every part which goes to make up the finished machine.

3. CONSTRUCTION OF MACHINERY

The beginning designer is almost always handicapped by a lack of knowledge of how machinery should be constructed. Such information is essential, however, if the designer is to turn out a good product.

This problem is dealt with in the chapters which follow. These chapters should be studied carefully and referred to frequently. Particular attention should be given to the illustrations and the accompanying explanations. In this way, many of the mysteries which seem to surround machinery design will disappear completely.

CHAPTER II

SUPPORT AND RETAINMENT OF ROTATING MACHINE PARTS

4. INTRODUCTION

Rotation is the motion most commonly found in machinery. Gears, belt pulleys, electric motors, automobile wheels, etc., all represent rotating machines or machine parts.

The rotating parts often carry heavy loads, and are almost always vital parts of the machine. It follows, then, that these parts must be carefully designed if trouble-free operation is to be obtained for a long period of time.

In the following paragraphs some basic rules are laid down for the support and retainment of rotating machine part, and some commonly used parts and assemblies are discussed and illustrated. It is not intended that this work illustrate all the constructions which are successfully used in machinery today. Instead, it is hoped that the basic ideas of support and retainment will be portrayed to the beginning designer in such a way as to call his attention to the problems involved, at the same time illustrating sound design practice.

5. BASIC PRINCIPLES

The fundamental requirements of support and retainment of rotating machine parts can best be expressed in the form of two brief rules:

- a. Every part of a rotating assembly must be supported radially.
- b. Every part of a rotating assembly must be retained or held axially.

As is shown in the following paragraphs, the first of these rules is the more easily satisfied of the two.

Figure 4 shows a simple set up of a single spur gear on a shaft with the shaft in turn supported in the housing by ball bearings.

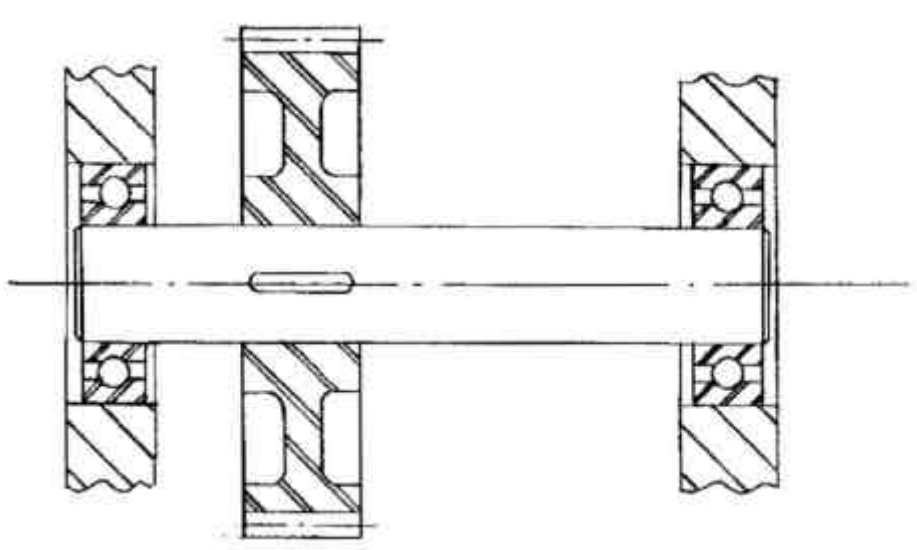

Figure 4

The gear and shaft are keyed together, hence rotate as a single unit. It would seem apparent that any radial force (one applied perpendicular to the shaft) applied to the gear is transmitted to the shaft, then thru the bearings to the housing or foundation of the machine. Or, as the arrows in figure 4 show, the housing provides the necessary reactions thru the bearings to hold the shaft and gear assembly in place. Since all parts are supported radially, the construction of figure 4 satisfies the first rule stated.

Figure 4 does not satisfy the second rule, however. Notice that while the gear is keyed to the shaft, it is free to slide, lengthwise, or axially, along the shaft in either direction. Furthermore, the shaft is free to slide lengthwise through the bearings and the bearings can slide in the housing.

To remedy this situation, and hence to satisfy the second rule, the construction can be changed, one step at a time, as follows:

- a. As shown in figure 4, the gear can slide to the right on the shaft. To prevent this, the diameter of the shaft between the gear and the right hand bearing can be increased as shown in figure 5. The diameter increase, or shoulder, at the gear, now prevents the gear from sliding to the right on the shaft.

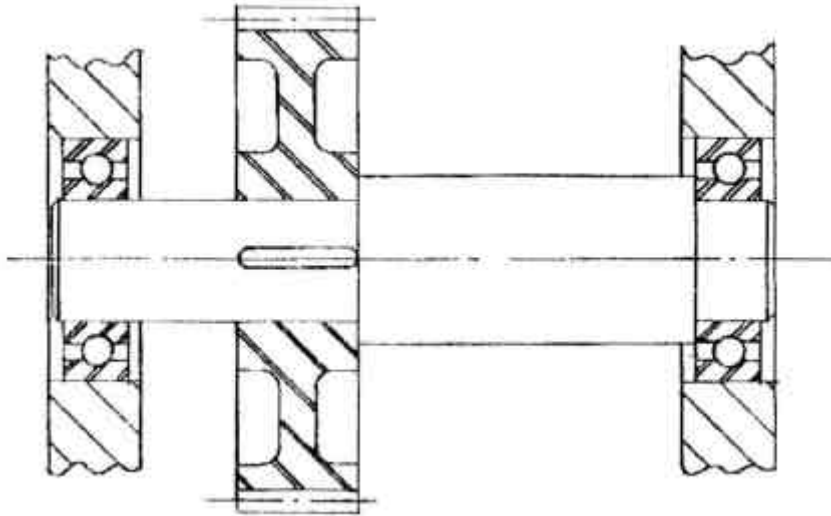

Figure 5

- b. In figure 5 the gear is still free to slide to the left along the shaft. However, the shaft diameter cannot be increased on the left side of the gear as was done on the right side, because of the impossible situation resulting. One way of keeping the gear from moving to the left is to put a sleeve, or spacer, between the gear and left hand bearing as shown in figure 6. This permits assembly and at the same time holds the gear in place.

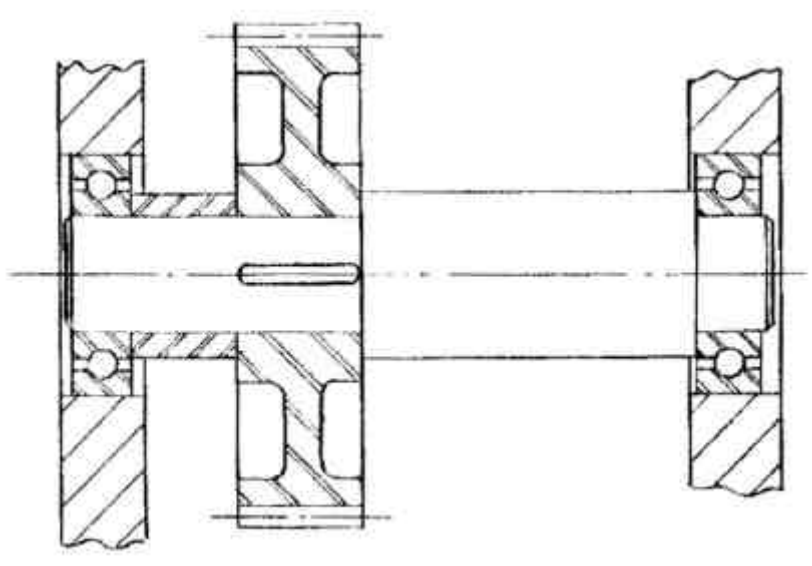

Figure 6

- c. Notice that this same construction that keeps the gear from moving lengthwise along the shaft also keeps the shaft from sliding through the bearings in this particular case. If the shaft tends to slide through the bearing to the right, the shaft shoulder catches on the bearing and prevents the sliding. Similarly, if the shaft tends to slide through the bearing to the left, the shoulder at the gear, the gear hub, and the spacer combine to keep the shaft from sliding through the bearing.
- d. It is now only necessary to hold the bearings so that they cannot slide in the housing. The addition of two shoulders to the housing, as shown in figure 7, will accomplish this. Note that all parts of the rotating assembly are now held axially, thus satisfying the second rule.

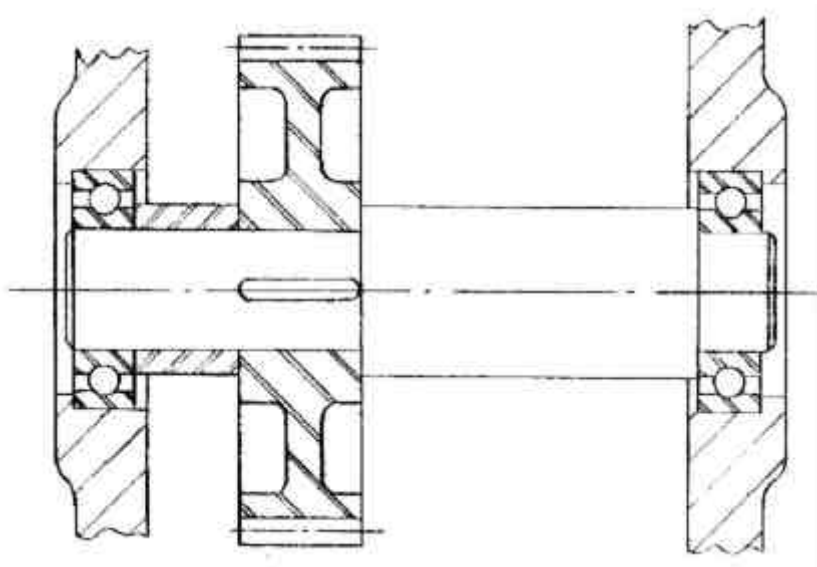

Figure 7

The preceding illustrations are not intended to show the only construction by means of which the rotating parts can be held axially. They are intended to show the principle involved, however, and as such should be studied carefully by the beginning designer. It is only necessary to refer to illustrations of machinery as found in numerous catalogs and technical magazines to find countless examples of other constructions used to hold the parts axially.

The example used in figures 4 through 7 was a simple construction and hence it is quite easy to see whether or not the parts are held axially. However, in more complex constructions where many parts are involved, it is often more difficult to see whether or not each part is held. Because of this the beginning designer should form the habit of considering each part of the rotating assembly separately to make sure it is properly held in place.

It might be pointed out that even though there are no apparent axial loads on the rotating assembly, it is still necessary to hold the parts axially. Otherwise vibration, misalignment, deflection of parts, etc., will combine to make the parts move axially.

Although the construction shown in figure 7 serves to hold the parts axially, it is not always the best construction. Figures 8 and 9 show constructions that are often preferred to that of figure 7.

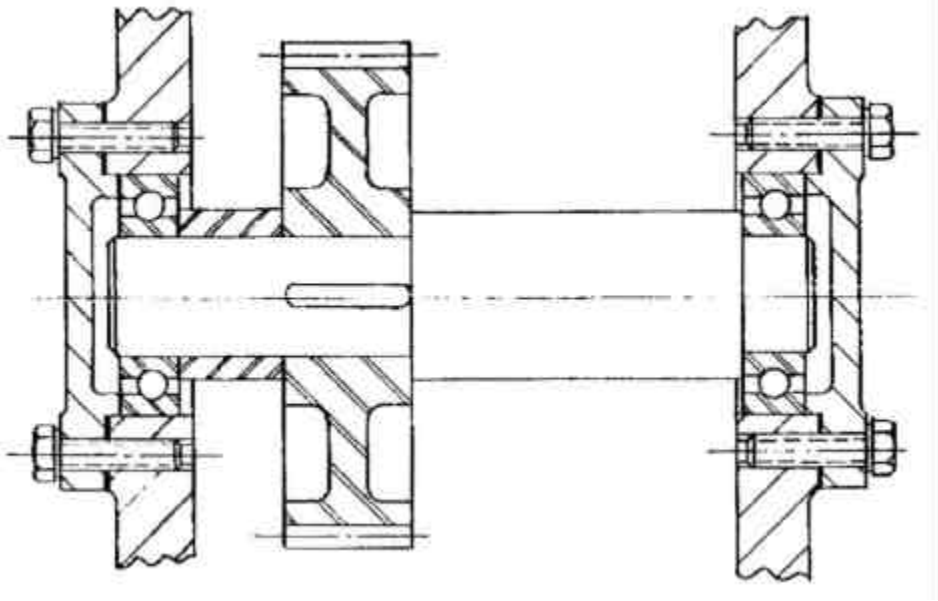

Figure 8

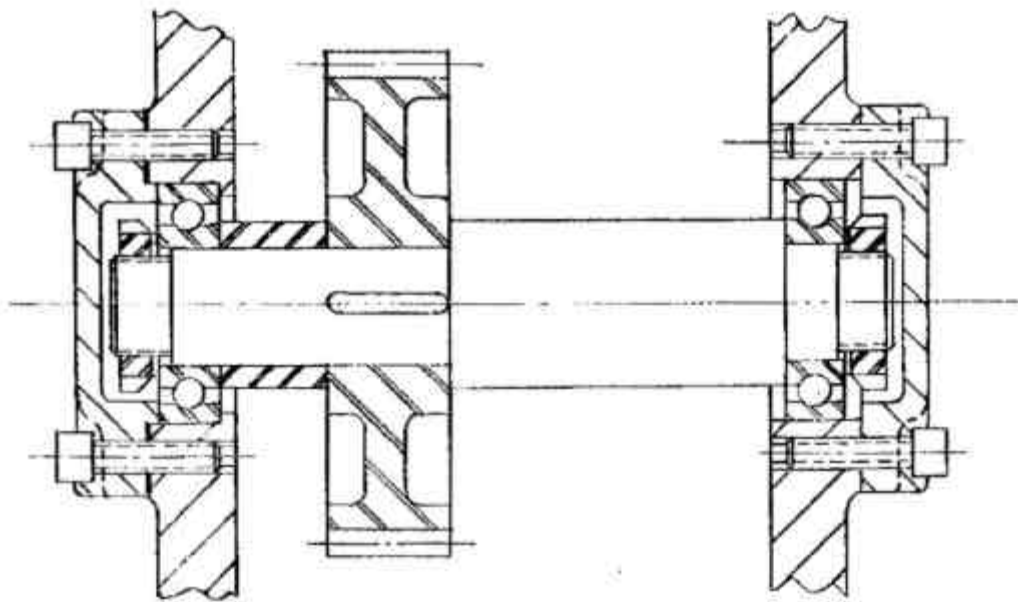

Figure 9

Notice that in figure 8 the shoulders in the housing have been replaced by removable caps. By placing thin steel spacers, or shims, between the housing and the caps, the location of the caps can be varied to compensate for manufacturing tolerances in the lengths of the parts assembled between the two bearings.

Probably the best construction is shown in figure 9. Notice that the left hand bearing holds the rotating assembly from movement axially in either direction, while the right hand bearing does no holding or locating of the rotating assembly. Locknuts have been used to clamp the inner race of each bearing to the shaft. These allow the left hand bearing to prevent axial motion to the right, and prevent the right hand bearing from sliding along the shaft to the right.

The construction shown in figure 9 allows for expansion of the rotating assembly due to change in temperature, and is not affected by manufacturing tolerances on the lengths of the parts assembled on the shaft.

Although figure 9 represents the best construction, the designer will often find that it is impossible, or at least not practical, to use this construction in all cases. The other constructions shown are widely used and perform satisfactorily under proper conditions.

In any event, when rolling bearings are used, the construction must be such that the axial holding is accomplished without having two surfaces sliding on one another. Otherwise, the advantage of the rolling bearings is completely lost.

If sliding bearings are used, the general idea of holding the parts is unchanged. In this case sliding surfaces, or thrust surfaces, are used to prevent axial motion. Figure 10 shows a construction using sliding bearings.

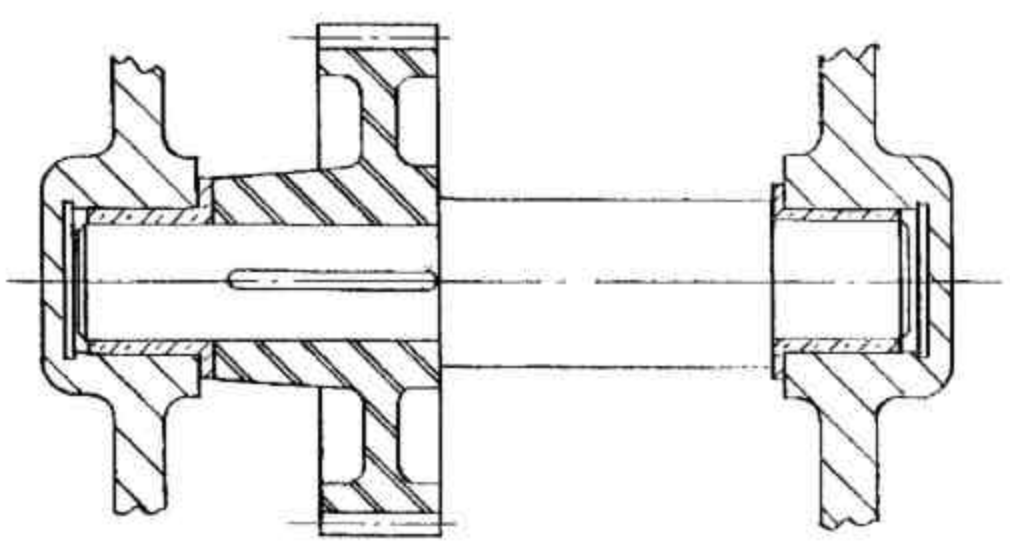

Figure 10

6. BEARINGS AND AUXILIARY PARTS

Bearings of one sort or another provide the support and retainment of the rotating assemblies in every case. Since the construction of the bearings themselves often influence the way in which the assembly must be constructed, a discussion of some of the common types of bearings is worthwhile at this time.

Almost all bearings, and particularly the rolling type, are made to standard sizes and must be fitted into the assembly just as they are supplied by the manufacturer. Manufacturer's catalogs can be consulted for the various sizes in which the bearings are available hence such information is not repeated here. The beginning designer should also familiarize himself with the numerous variations of the basic bearings, all of which are useful in design work.

A brief discussion of auxiliary mounting parts, such as lockwashers, retainer rings, etc., are also included in the following paragraphs.

7. BALL BEARINGS

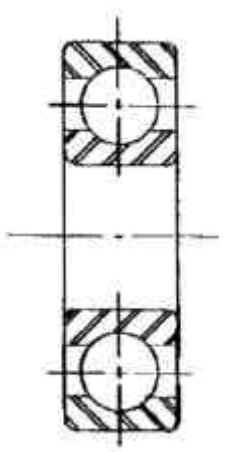

Figure 11

Figure 11 shows the cross section of a single row deep groove radial ball bearing. This is the most widely used of all the rolling types of bearings. Note that the balls roll in grooves in both the inner and outer races. Because of these grooves, this bearing is capable of holding axial, or thrust, loads as well as radial loads. Furthermore, it can carry the axial loads in either direction.

It is the ability of this bearing to carry both radial and axial loads, individually or in combinations, and in any direction, that makes this bearing so useful to designers. This same basic bearing is also made with various combinations of shields, seals, and retainer rings. The beginning designer is referred to manufacturers' catalogs for further information on this bearing and its variations.

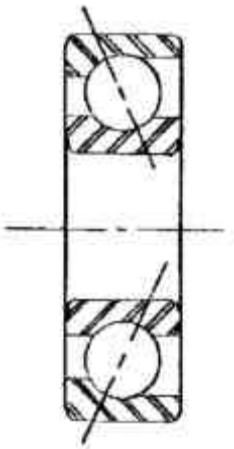

Figure 12

Figure 12 shows an angular contact ball bearing. Note the offset races which allow the angular contact.

Because of the angular contact races, it is possible to get more balls into the bearing, and these bearings, therefore, have somewhat more radial load capacity than the deep groove bearings. In one direction only, they have a large axial load capacity.

This bearing is commonly used in installations where no clearance is permissible in the bearings. By using the bearings in pairs and providing a small axial pre-load at

assembly, the small amount of clearance present between the balls and the races can be removed.

Excessive axial pre-loading will greatly shorten the life of the bearings, so means of carefully controlling this pre-loading should be provided in most cases.

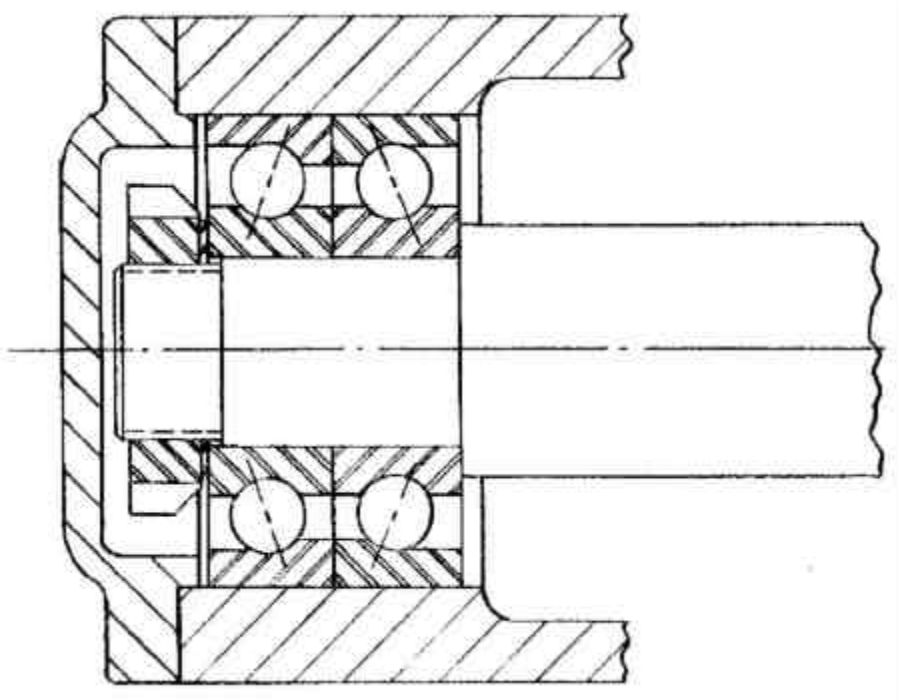

Figure 13

Figure 13 shows one method of controlling the pre-load of the angular contact bearings. The bearings are here used in pairs, and in such a case, the races are so made that when the outer races come together, there is still a small axial gap between the inner races. Tightening the locknut forces the inner races of the two bearings together, thus applying the axial pre-load. The amount of pre-load is controlled by the amount of the gap built into the bearings at manufacture.

Again the designer is referred to the bearing catalogs for illustrations of other methods which can be used to pre-load these bearings.

Although these bearings are widely used in machine tools and similar installations, most machinery is not affected by the small amounts of clearance present in the ordinary deep groove bearings shown in figure 11. When such is the case, pre-loaded bearings are not necessary.

8. STRAIGHT ROLLER BEARINGS

Figure 14 (a,b,c) show some straight roller bearings. Although these bearings have a greater radial load capacity than a ball bearing of the same size, in most cases they can carry no axial load whatsoever.

The bearing shown in figure 14 (a) can in some cases retain parts where no real axial loads exist. Notice, however, that axial loading causes the ends of the rollers to slide under load on the shoulders of the race, thus defeating the purpose of using a rolling type of bearing.

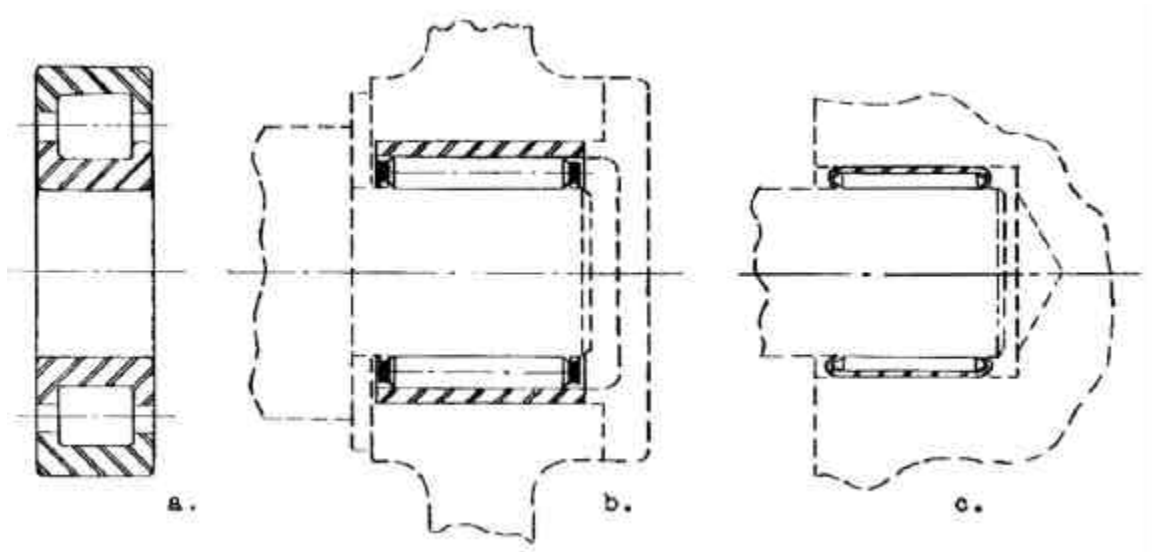

Figure 14

Figures 14 (b,c) show roller bearings which cannot carry any axial loads but have substantial radial load capacity. If no axial loads are present, parts can be held axially by means of sliding surfaces as shown in figure 14 (b). Ball or roller thrust bearings, dealt with further on, can be used in place of the sliding surfaces if axial loads are present, although such a construction often tends to get large and unduly complicated.

Roller bearings can be used with or without races, hence can be effectively utilized where space is limited in such a way that the bearing outside diameter must be small.

As with the ball bearings, the designer should look through the catalogs of the roller bearing manufacturers for further information on these bearings and their uses.

In those installations where one of the bearings supporting a shaft carries a much greater radial load than the other bearing, a ball bearing and straight roller bearing are often used together as shown in figure 15.

Notice that in this case the ball bearing holds the parts axially in both directions, while the roller bearing carries the large radial load caused by the belt tensions.

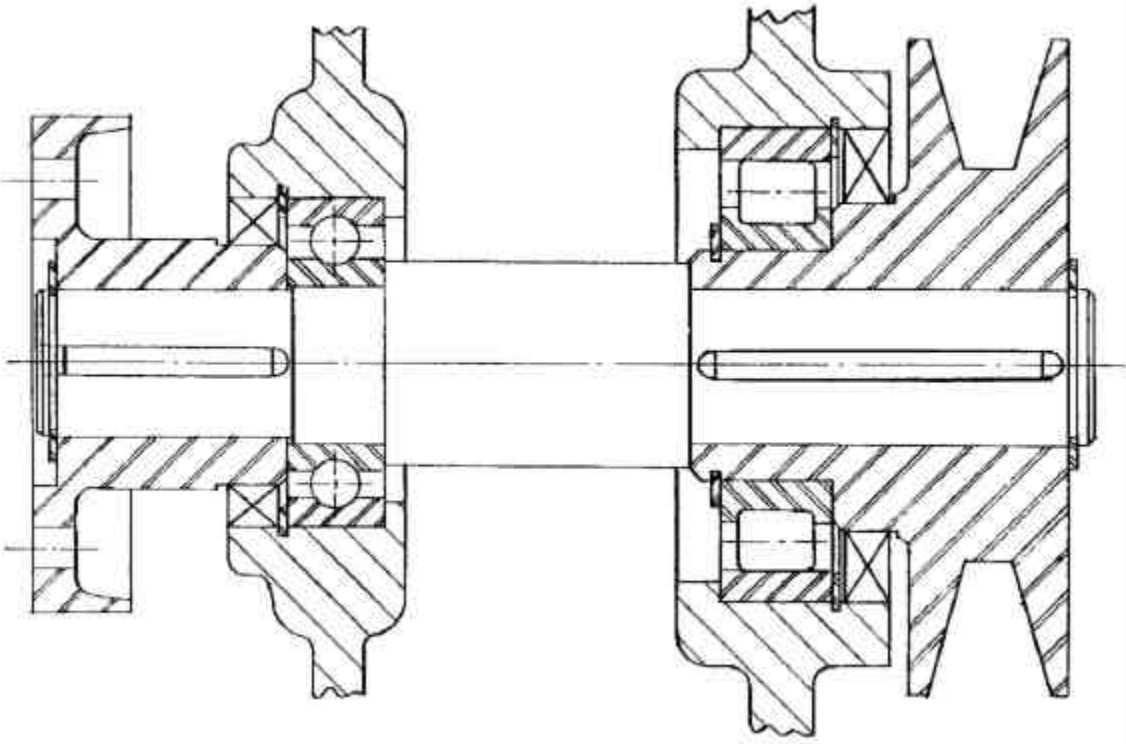

Figure 15

9. TAPERED ROLLER BEARINGS

Figure 16 shows a tapered roller bearing in which the rollers and the races are elements of cones converging at a common point as shown.

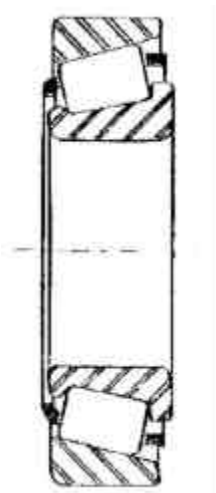

Figure 16

Tapered roller bearings are primarily intended to support radial loads. Because of their conical construction, however, they can also carry very substantial axial loads, but in one direction only.

Notice in figure 16 that if the inner race is pushed axially toward the left by forces on the shaft, the bearing can hold the shaft so it cannot slide to the left, but that an axial force to the right would cause the cone and roller assembly to simply pull out of the outer race or cup.

Because they can carry axial loads in one direction only, these bearings must always be used in pairs, and must be mounted in such a way that axial loads in either direction can be successfully carried.

Furthermore, because of the conical construction of these bearings, means must be provided at assembly to adjust axially the position of one race relative to the other to hold the bearings together. Otherwise, manufacturing tolerances on various parts might combine so as to force the inner and outer race so tightly together that no rotation is possible, or might have them so far displaced from one another that excessive radial clearance results.

Two different methods of providing this necessary adjustment are shown in figures 17 and 18. Notice in figure 17 the adjusting is done by means of the outer race by shimming the caps until the bearings are held snugly together.

In figure 18 the same result is obtained by tightening the locknut so as to adjust the position of the inner races.

Although the constructions shown above are satisfactory for most machinery, it does not allow for any expansion of the shaft assembly due to temperature changes. If allowances must be made for expansion, a coned disc spring or Belleville spring can be inserted between the outer race of the bearing and the adjusting cap in figure 17.

As before, the designer is referred to the catalogs of tapered roller bearing manufacturers for further information.

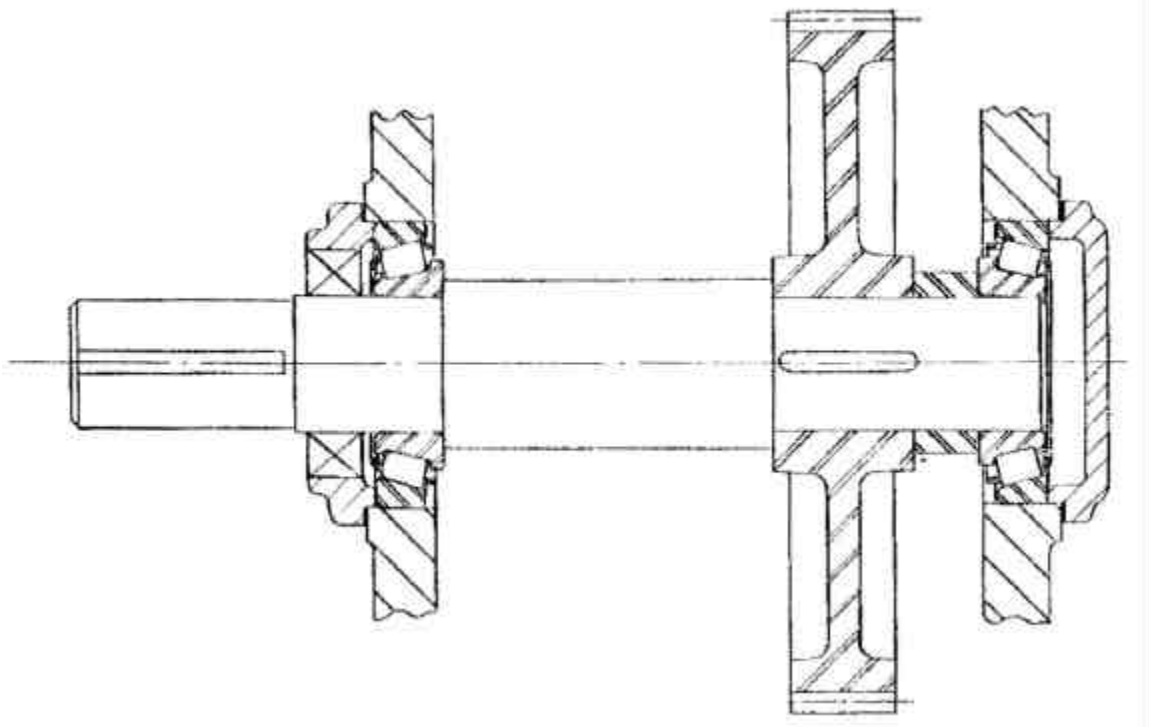

Figure 17

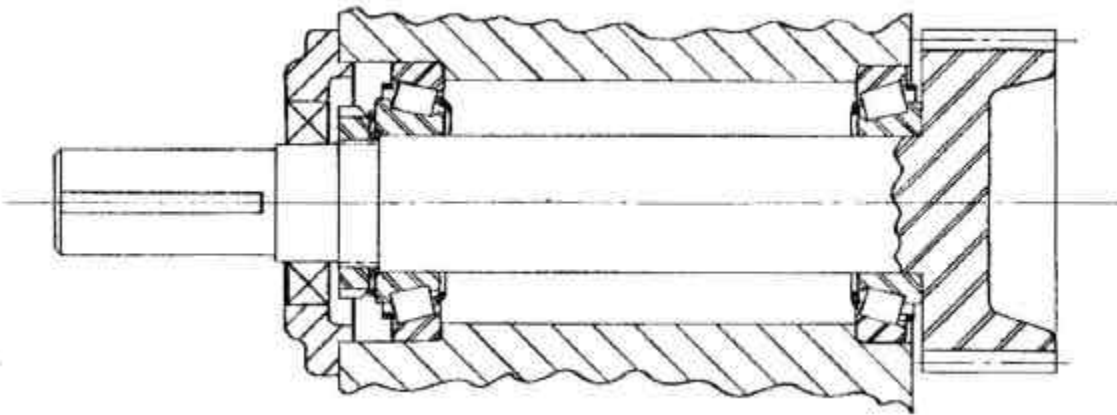
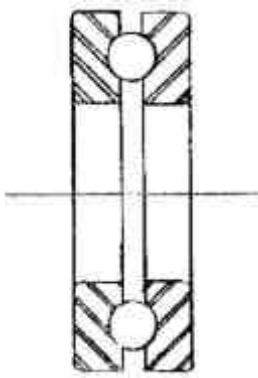

Figure 18

10. BALL AND ROLLER THRUST BEARINGS



Ball and roller bearings can also be made in such a way that they can carry axial loads only. Such bearings are known as thrust bearings.

A ball thrust bearing is shown in figure 19. Note that the bearing races are perpendicular to the shaft rather than parallel to it; hence, these bearings can carry no radial loads. These bearings are generally used together with radial ball or roller bearings when large axial loads must be carried.

Figure 19

11. LOCKNUTS AND RETAINER RINGS

Locknuts and retainer rings are commonly used to hold parts together on a shaft.

The locknuts commonly used have shallow threads, and are round instead of hexagonal in shape. A series of grooves cut into the cylindrical surfaces allows the nut to be gripped for tightening by a "spanner" wrench. A lockwasher, which is keyed to the shaft, is used to prevent the locknut from coming loose.

Locknuts and lockwashers have been standardized and available sizes can be found in almost any bearing catalog or in the SAE Handbook.

Retainer rings are generally purchased as a standard item and manufacturers' catalogs should be consulted to determine available sizes. In addition to holding parts on the shafts, they can be used to hold parts in housings, both uses being illustrated in figure 15.

When retainer rings are used on a shaft, extreme caution must be exercised by the designer so as not to place the groove which must be cut in the shaft in such a position as to greatly reduce the bending fatigue strength of the shaft.

Figure 20 shows four different installations of retainer rings on shafts, three of which are satisfactory and one unsatisfactory.

In figure 20(a), the ring is installed at the end of the shaft to hold the bearing. Since there is no bending load on the shaft at this point, the groove does not affect the bending fatigue strength of the shaft.

Figure 20(b) shows the ring installed at a point where the shaft might very likely be stressed in bending. The effect of the groove would be to greatly reduce the bending fatigue strength, hence this construction should be avoided.

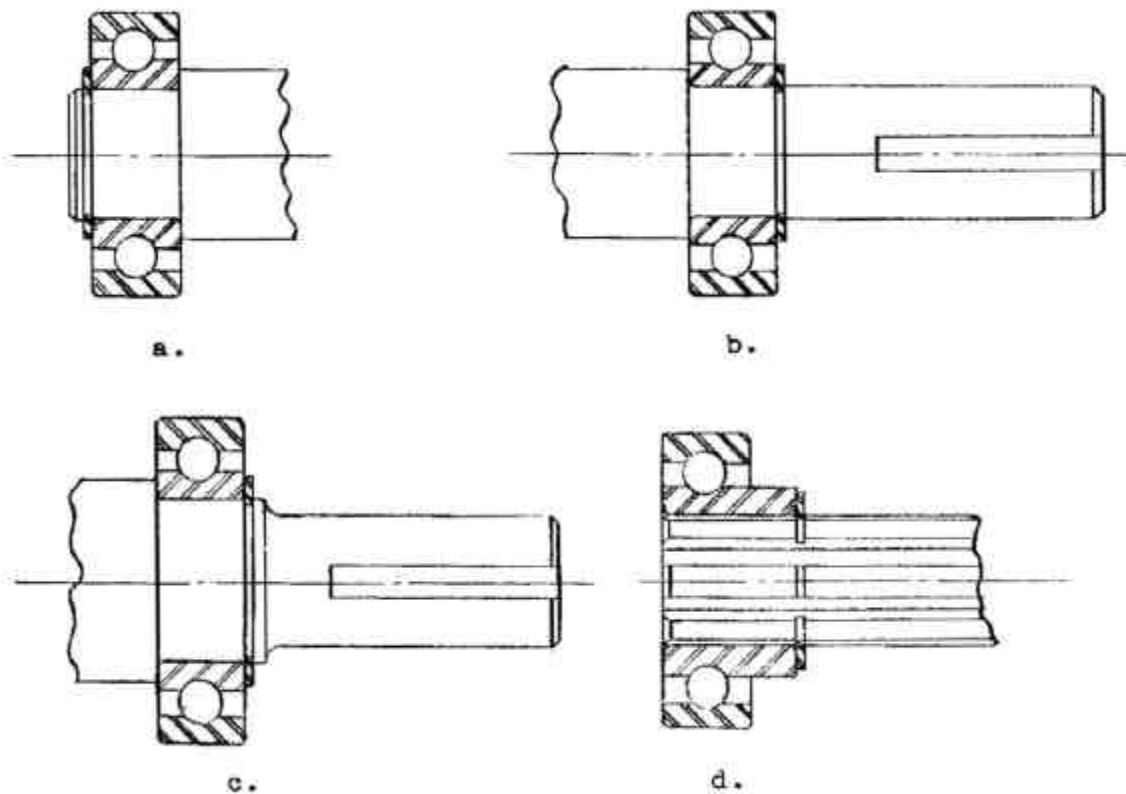

Figure 20

Changing the construction of 20(b) to that shown in 20(c) would be an improvement since the bending fatigue strength of the shaft is not greatly reduced if the ring groove is placed in the enlarged section, right next to the shoulder, and a rather generous fillet radius is used.

Figure 20 shows a splined shaft with the ring groove cut in the splines. So long as the groove does not extend to the root diameter of the splines, the groove has little effect on the bending fatigue strength of the shaft and this construction is permissible.

12. SLIDING BEARINGS

A sliding bearing is one in which the shaft slides on the surface of the bearing as it rotates. In its simplest form, such a bearing would consist of nothing more than a hole in the housing wall or frame into which the end of the shaft was inserted.

To operate with reasonable loads and speeds, however, a relatively soft metal bearing is inserted between the housing and the shaft slides on the surface of the insert.

These bearings are commonly made of bronze, formed by the powdered metal process and are available in a large number of standard sizes. If necessity demands, they can also be machined quite easily to almost any size other than standard.

Figure 10 showed a construction using this type of sliding bearing.

Not all sliding bearings are made of bronze, nor do they necessarily look like those shown in figure 10. Lead-tin compositions known as Babbitt, cadmium-silver, copper-lead, and aluminum are also used as materials for sliding bearings. These materials are often plated in a thin layer on steel or bronze so as to have sufficient crushing strength.

One of the nice features of the sliding bearing is the fact that it can be made in two halves and placed around the shaft. This often lends itself to an assembly that would otherwise be difficult if not impossible.

The main design features of sliding bearings are most often dictated by lubrication requirements, hence no extensive coverage of this is included here. The principles illustrated in the following paragraphs applies equally well to both sliding and rolling types of bearings.

13. OIL AND GREASE SEALS

Where shafts enter or leave a housing, a seal must be provided to hold the lubricant in and to keep the dirt out.

A lip type of seal, shown in figure 21(a), is the type most commonly used. It consists primarily of a ring of neoprene or leather which is held against the shaft by a spring. The neoprene or leather ring and the spring are enclosed in a stamped metal cylinder which is pressed into the housing for support. As the shaft turns, it rubs constantly on the neoprene or leather ring providing an effective seal.

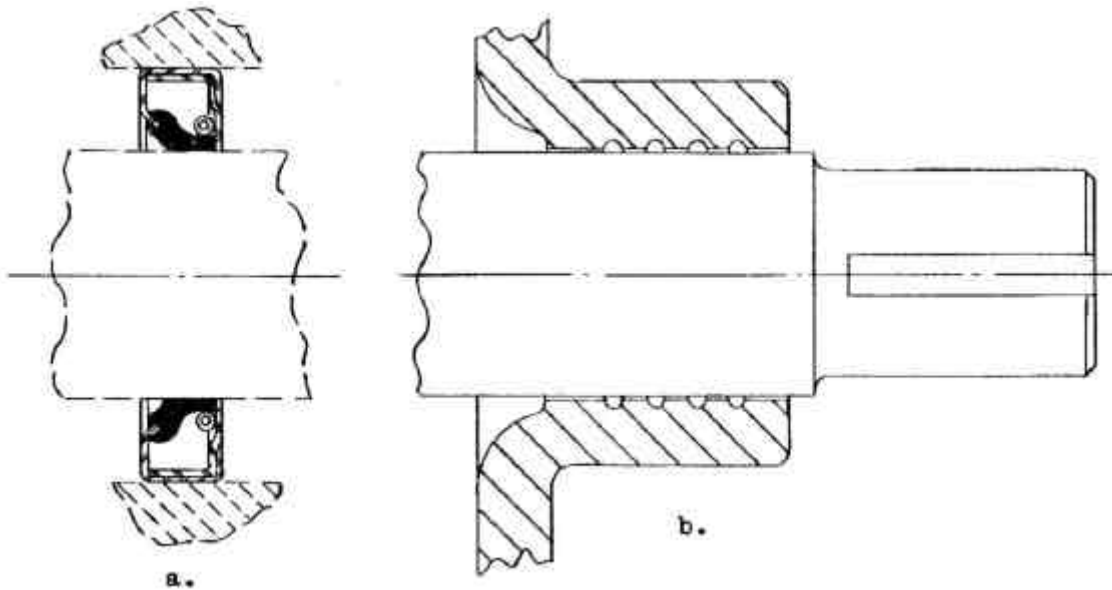

Figure 21

These seals are generally purchased items, and as with bearings, the designer should consult the manufacturers' catalogs for sizes and types available.

Although the lip type of seal is satisfactory in most cases where speeds are very high, where high temperature is encountered, or where the lubricant is under pressure, other types of seals are also used. One of these other kinds, a labyrinth seal, is shown in figure 21(b).

14. COMMON CONSTRUCTIONS

Having established the basic principles of support and retainment, and having discussed some of the more common types of bearings and auxiliary parts, it is now worthwhile to illustrate some common constructions used to support and retain rotating parts.

Again it might be pointed out that this does not intend to show all the constructions successfully used in machinery today. However, the following paragraphs will serve to show the designer some sound constructions which can be commonly utilized in his design work.

15. OVERHUNG MOUNTINGS

Most of the illustrations thus far have shown parts supported on the shaft between the bearings. However, the parts to be supported can also be mounted so as to overhang the bearings as shown back in figures 15 and 18.

It is always best to mount the parts between the bearings wherever possible since the best support can be obtained in this way. The overhung mounting can be used successfully, however, if care is exercised to keep the overhang very short by having a bearing immediately adjacent to the part supported on the shaft and to have a reasonably large spacing between the bearings.

Even in those installations where the overhanging portion carries no load, a long overhang will be troublesome. This is largely due to the fact that shafts cannot be made perfectly straight. A long overhang allows this inherent lack of straightness of the shaft to cause the supported part to rotate off center thus causing poor operation, vibration, etc.

To get the bearing close to the overhang member, and at the same time have a bearing large enough to carry the large loads imposed on this bearing with this type of support, it is often desirable to mount the bearing directly on the nub of the member being supported. Such a construction is shown in figure 15.

16. SUPPORTING ONE SHAFT INSIDE ANOTHER SHAFT

A designer often has occasion to have two separate shafts in line with one another as shown in figure 22.

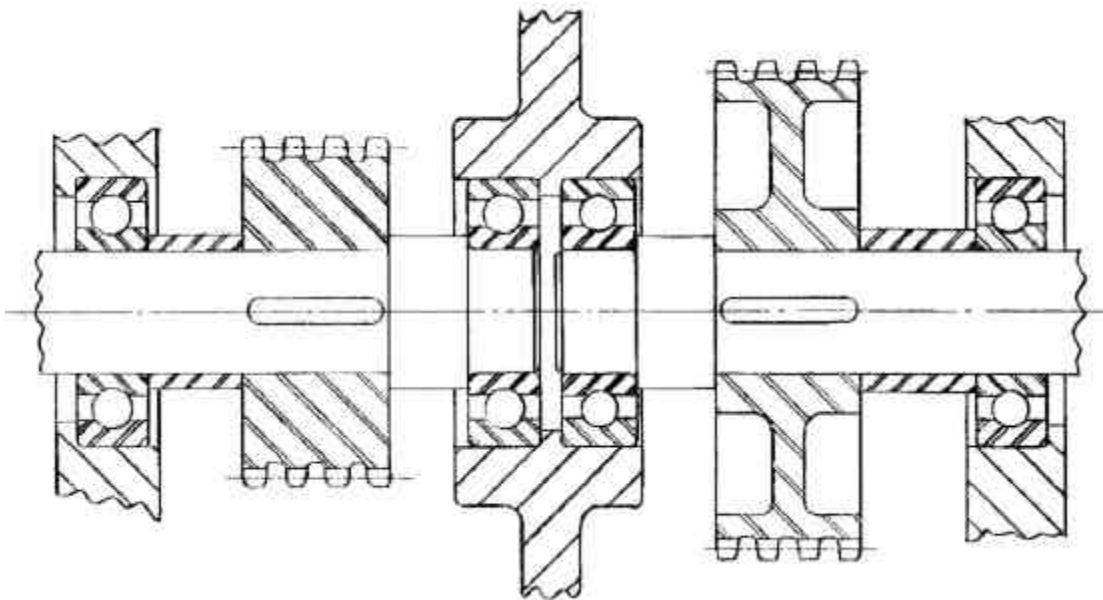

Figure 22

A considerable amount of space is required by having two bearings side by side as shown. The space required can often be reduced by supporting one shaft inside the other as shown in figure 23. The space saved allows the entire construction to be shortened thus making the machine more compact.

The construction of figure 23 can be used successfully if the supporting shaft and its bearings are large enough to carry the additional loads imposed. Because errors due to lack of concentricity and straightness are compounded by this construction, it is necessary that the inner bearing be inside, or right next to, the outer bearing.

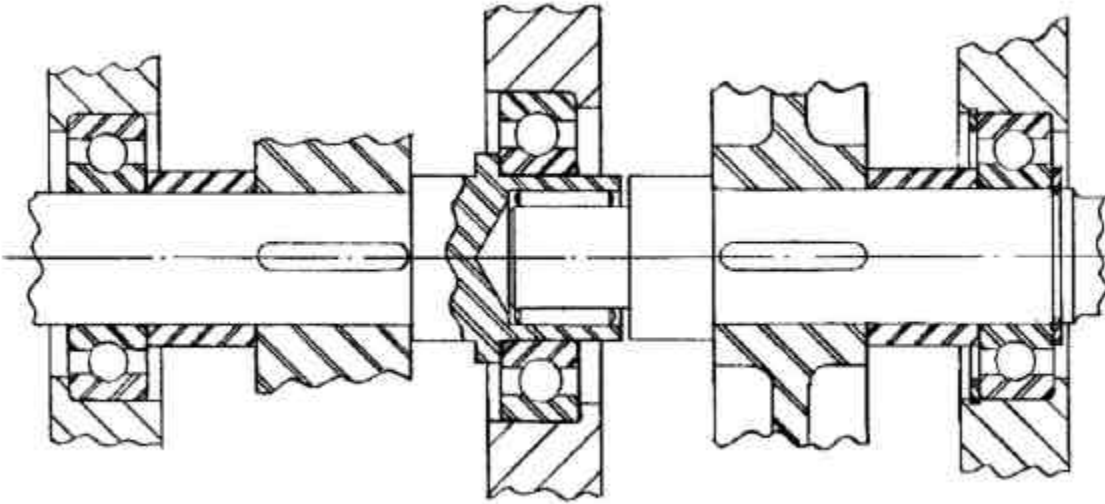

Figure 23

The beginning designer is often tempted to carry this construction one step further and eliminate the outer bearing completely, as shown in figure 24.

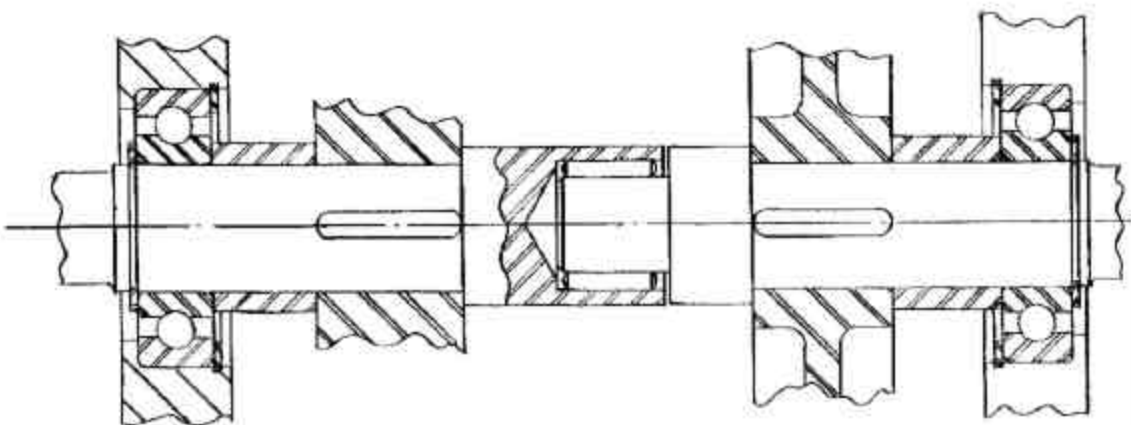

Figure 24

This construction is entirely unsatisfactory since the inner bearing must now serve to hold the two shafts in line, thus sustaining heavy loads on its corners which will cause premature failure of the bearing. The designer must always be careful to first support the housing or frame one of the shafts involved. This supported shaft is then capable of supporting one end of another shaft.

17. DEAD SHAFT CONSTRUCTION (AXLE)

In certain cases, a more compact construction can be obtained by having the shaft stationary allowing the supported parts to rotate on the "dead" shaft. Such a construction is shown in figure 25.

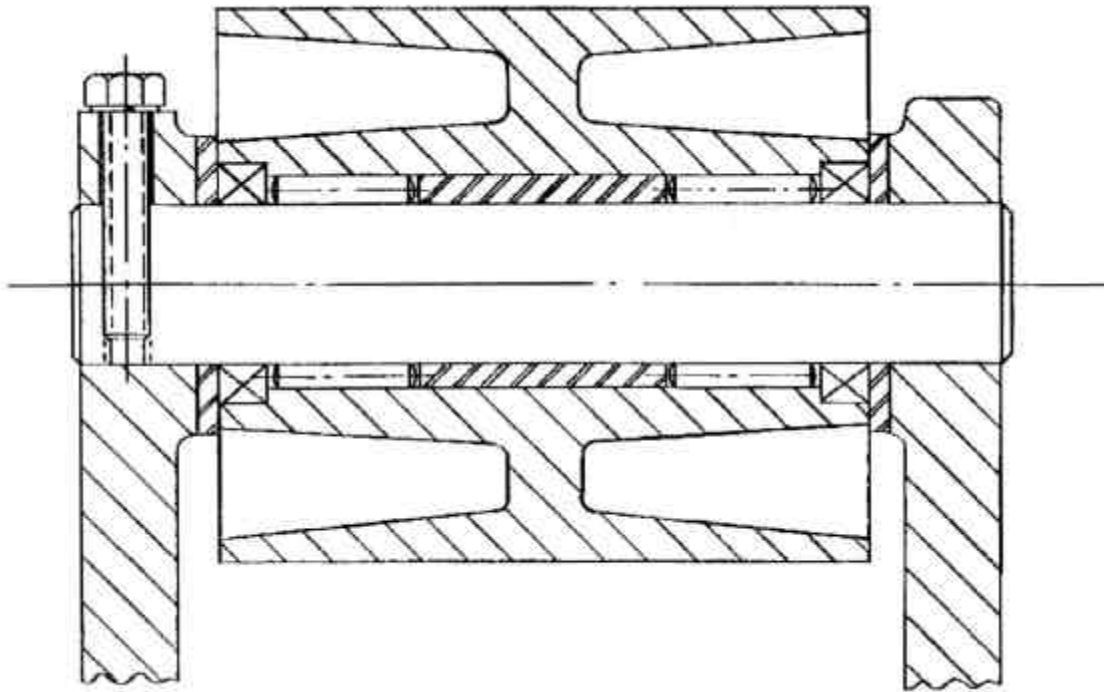

Figure 25

For best results the shaft should be secured to the housing so that it cannot move. Loose rollers, rather than a bearing assembly, are commonly used as shown in figure 25 with sliding thrust surfaces to prevent excessive axial freedom.

18. SUPPORTING BEVEL GEARS

Since bevel gears are cut on cones, the clearance between the teeth is affected by any variation in the location of the bevel gears on their shafts. Since manufacturing tolerances affect the location of the gears when the machine is assembled, means must always be provided to allow adjustment of the position of the bevel gears at assembly. This adjusting is best accomplished by the use of shims to provide a positive location once the adjustment has been completed.

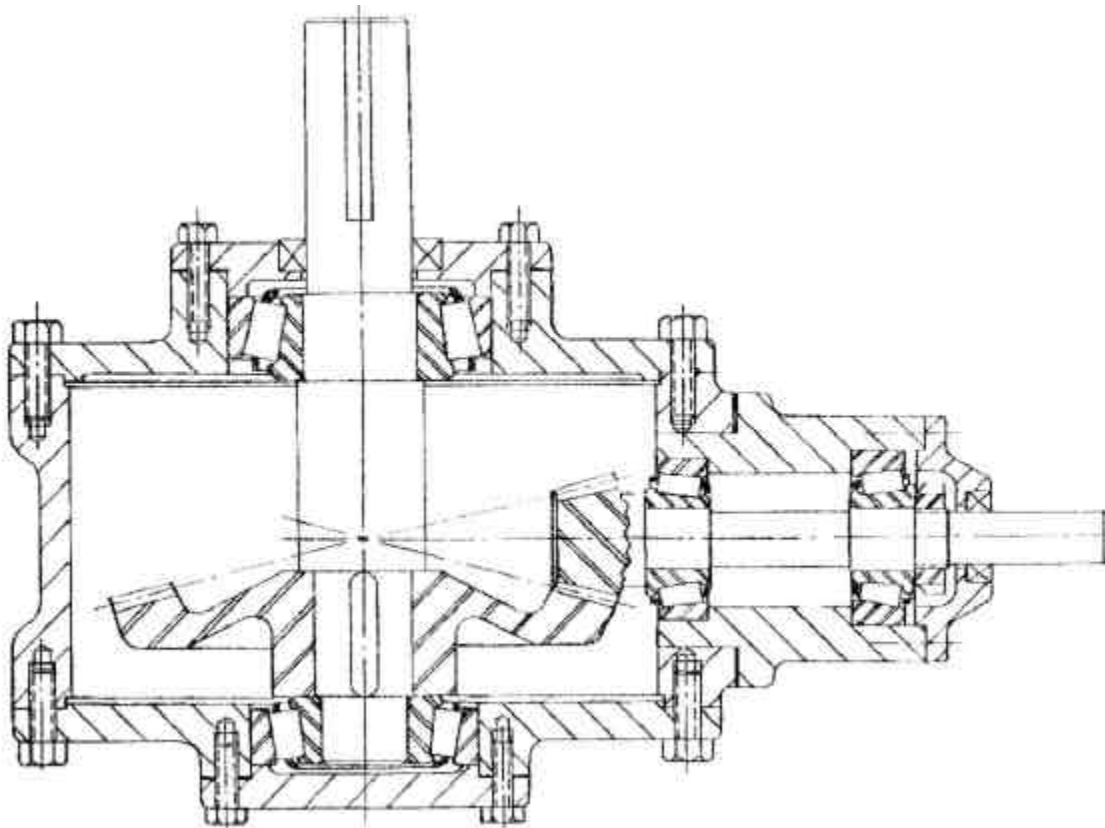

Figure 26

Figure 26 shows a typical construction that might be used. Notice that by shimming the caps holding the output shaft bearings, the entire output shaft assembly can be adjusted to get the bevel gear teeth in the theoretically-correct position relative to the pinion center-line.

The cartridge mounting of the bevel pinion and shaft assembly allows shims to be used between the cartridge flange and the housing to adjust the position of the pinion as so to obtain the correct gear tooth clearance.

19. SUPPORTING WORM GEARS

Figure 27 shows a worm gear mounting. Because the teeth of the gear are cut in a concave surface so as to partially wrap around the worm as shown, it is necessary that the gear be so located that the center-line of its face lines up with the center-line of the worm axis. This condition is shown in figure 27, but to obtain it in a machine, means must be provided to adjust the gear position axially at assembly. As with the bevel gears, shimmed caps as shown present one method of getting this adjustment.

No adjustment is needed on the worm location, since the operation of the worm and gear is not affected by axial variation in the position of the worm.

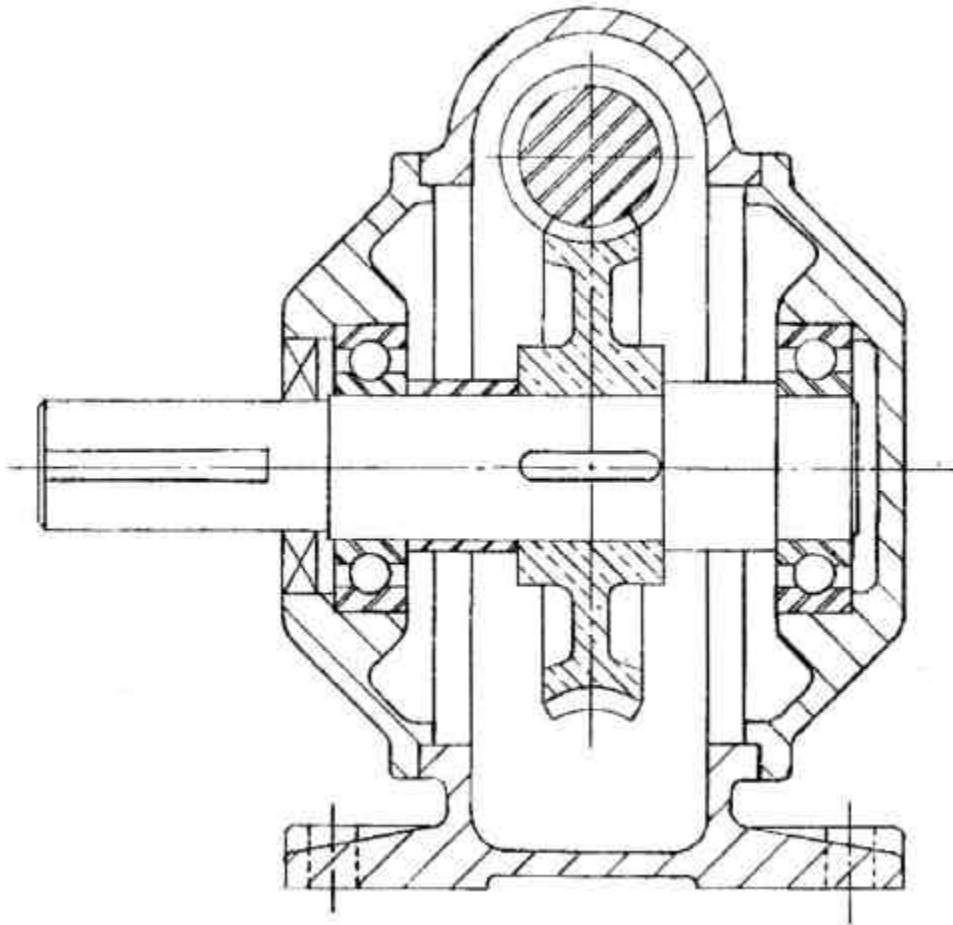

Figure 27

20. NUMBER OF BEARINGS ON ONE SHAFT

It is necessary to support a shaft at two points at least to obtain stability. Hence, it follows that at least 2 bearings are needed to support a shaft.

The use of more than two bearings on a shaft should be avoided, however, since the shaft then becomes redundant and any misalignment of the bearing bores in the housing will cause excessive loads on the bearings. Thus it is seen that the addition of a third bearing often does more harm than good.

Exceptions to the rule of only two bearings to support a shaft sometimes occur, however. This is particularly true on long shafts of small diameter or on shorter shafts where extreme rigidity is required. The designer should give very careful consideration to any construction requiring more than two bearings to support a shaft, however, because of the problems involved.

CHAPTER III

CLUTCHES

21. INTRODUCTION

A clutch is a device which engages one rotating part to another rotating part in such a way that the parts can be readily engaged and dis-engaged. Clutches can be roughly grouped into two general types, namely, positive acting clutches and friction clutches.

22. POSITIVE ACTING CLUTCHES

A positive acting clutch is one that is incapable of slipping. It follows that unless a synchronizing device of some form is provided, a positive acting clutch can only be engaged when the two halves are stationary or are turning at approximately the same speed.

A relatively small clutch of this type has a large torque capacity, and because only a small axial force is required to engage or dis-engage a positive acting clutch, a simple operating linkage can generally be used.

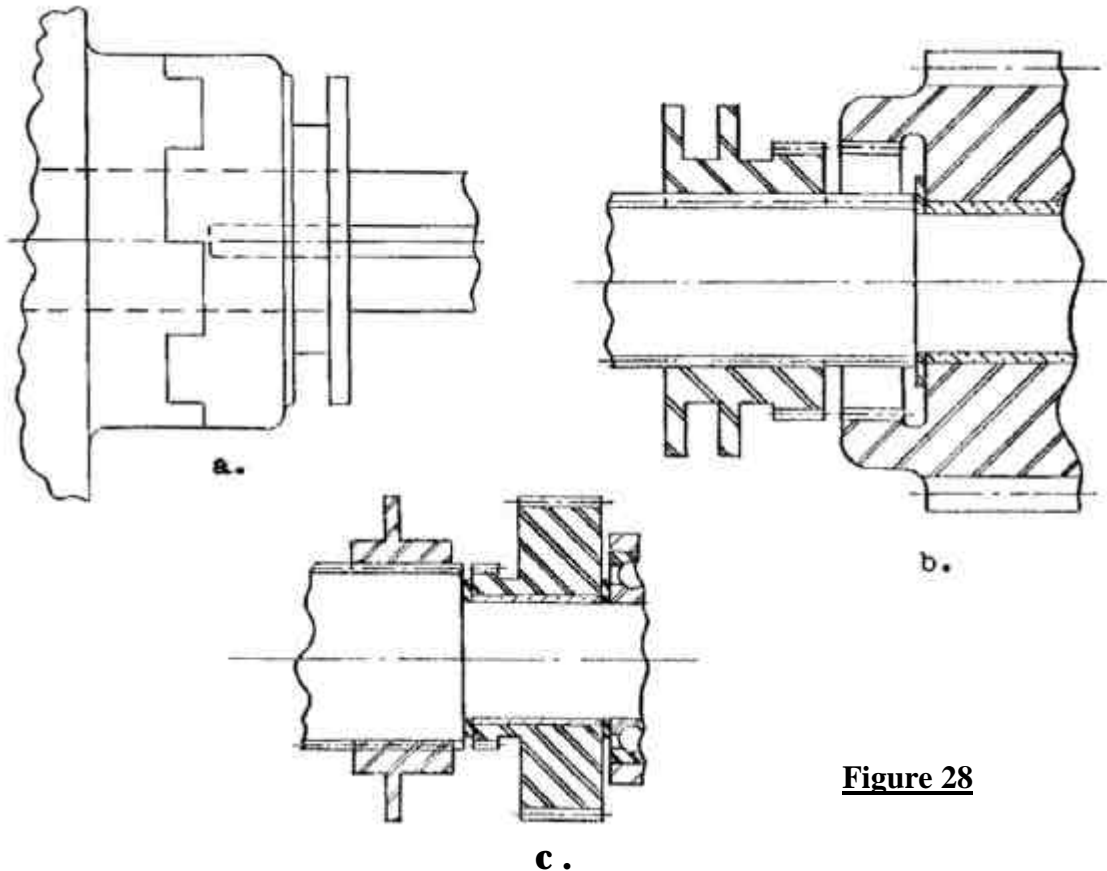

Figure 28

Positive acting clutches are shown in figures 28(a,b,and c). The clutch shown in 28(a) is known as a jaw clutch or dog clutch.

This type of clutch lends itself readily to a simple, rugged construction, but because the teeth or jaws converge toward the center, it is not especially easy to manufacture. Furthermore, it has a tendency to become dis-engaged if the sides of the jaws are slightly slanted due to wear, deflection, or inaccuracies of manufacture.

The clutches shown in figures b and c are spline tooth clutches. Involute splines are most commonly used for such clutches, although flat splines can also be used successfully in some cases. The relative ease of manufacture of the involute spline, both internal and external, contributes considerably to the advantages of the spline type of clutch.

23. FRICTION CLUTCHES

As the name implies, a friction clutch transmits torque by virtue of a friction force developed, hence can slip under certain conditions. Thus a friction clutch can be engaged while the driving member is turning and the driven member is stationary. Because of this the friction clutch is more useful than a positive acting clutch.

Although many friction devices have been used as clutches, today only the disk clutch and cone clutch are widely used. These will be considered separately.

24. FRICTION DISK CLUTCH

A disk clutch, or plate clutch as it is sometimes called, consists essentially of two or more disks or plates, and a suitable means of holding the disks together to develop the necessary friction force. The main advantage of the disk or plate construction lies in the possibility of using a large number of disks together so as to obtain a large torque capacity. A disadvantage is the necessity of providing a large axial force to hold the disks together all the time the clutch is engaged.

The disks are commonly made of metal. If the disks are to operate in oil, disks of hardened steel, or alternate disks of bronze and hardened steel are generally used.

Because oil greatly reduces the friction coefficient between the disks, most clutches are kept free of oil, and thus operate dry. In such a case, metal disks have a tendency to score during the slipping period at engagement, hence every alternate surface is commonly formed of molded asbestos. This is accomplished by riveting or bonding a layer of the asbestos to the metal disk, or by using alternate disks of solid molded asbestos.

The asbestos has the added advantage of having a relatively high coefficient of friction and good wearing qualities.

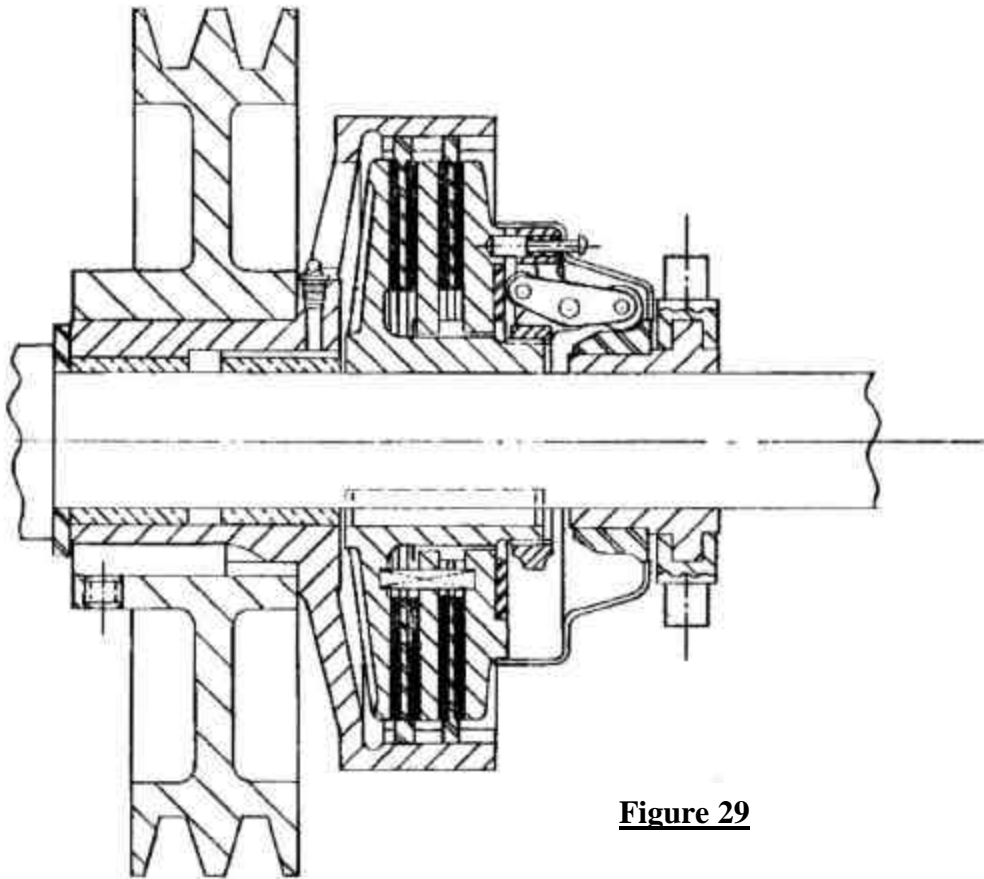

Figure 29

Figure 29 shows a typical industrial disk clutch of the dry type. In this particular illustration, there are two outer disks and three inner disks, thus providing four pair of friction surfaces. The inner disks are steel or cast iron, while the outer disks are made of steel with molded asbestos facings.

External teeth cut in the circumference of each outer disk fit into internal teeth cut in the housing which surrounds the outer disks. Thus the outer disks turn with this housing, but are free to slide axially in the housing.

In a similar manner the inner disks are fastened to the large shaft sleeve, turning with the sleeve, but free to slide axially.

A rather elaborate operating linkage, typical of disk clutches, is shown in figure 29. This linkage must perform two functions:

1. It must provide a very substantial mechanical advantage so that the large axial force required on the disks can be produced by the application of a relatively small force on an operating handle.
2. Once the clutch is engaged, the linkage must hold the clutch in engagement so that it is not necessary to continuously exert a force on the operating handle.

The clutch linkage shown in figure 29 accomplishes both of the above by means of several of the rocker levers shown spaced at equal intervals around the clutch. When the engaging sleeve is forced to the left, the force applied to the sleeve is multiplied by the lever and is then applied to the first disk, or pressure plate, as this first disk is commonly called. Thus the inner and outer disks are all squeezed together against the left hand inner disk which is immovable.

If the slant on the engaging sleeve is not too steep at the point where the roller comes to rest when the clutch is engaged, the linkage will be non-reversible. Thus the linkage will hold the clutch in engagement, continuing to exert the force on the disks until the clutch is released by forcing the engaging sleeve to the right. However, a relatively steep slant is provided at the left end of the engaging sleeve so as to quickly take up the clearance between the disks and hence shorten the movement needed to engage the clutch.

It will be noted that the clutch is so constructed that the large axial force exerted on the disks is not transmitted to the shaft and therefore does not have to be held by the bearings. To be successful, every disk clutch must accomplish this same thing, otherwise the thrust or axial loads on the bearings would be excessive.

An adjusting device must also be provided to compensate for wear and manufacturing tolerance. This adjusting device should be rather simple to operate but must be so made that it can be locked in place to prevent it from coming loose during operation of the clutch. In figure 29 the adjustment is accomplished by turning the threaded collar which supports the rocker levers.

Two more clutches are shown in figures 30(a and b).

A double clutch, operated in oil, is shown in figure 30(a). A large number of relatively small diameter disks are used to get the necessary torque capacity.

The clutch shown in figure 30(b) has solid molded asbestos outer disks and operates dry. A ball and wedge type of operating linkage is used.

If the clutch operates at reasonably high speed, the operating linkage may be adversely affected by centrifugal force, and this should be considered when designing the linkage.

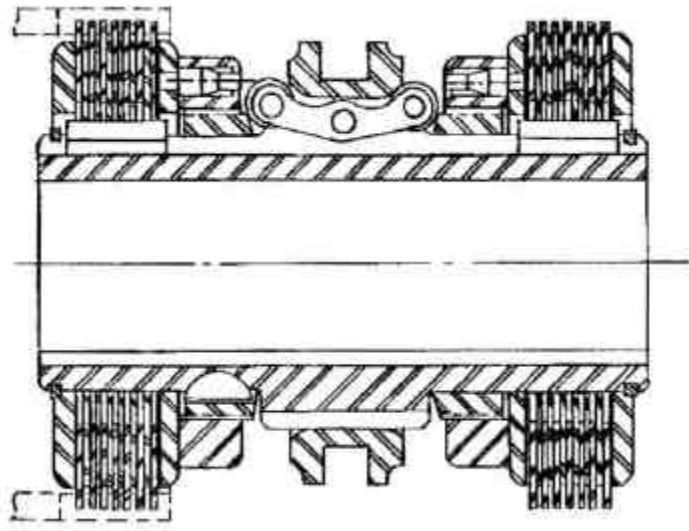

Figure 30(a)

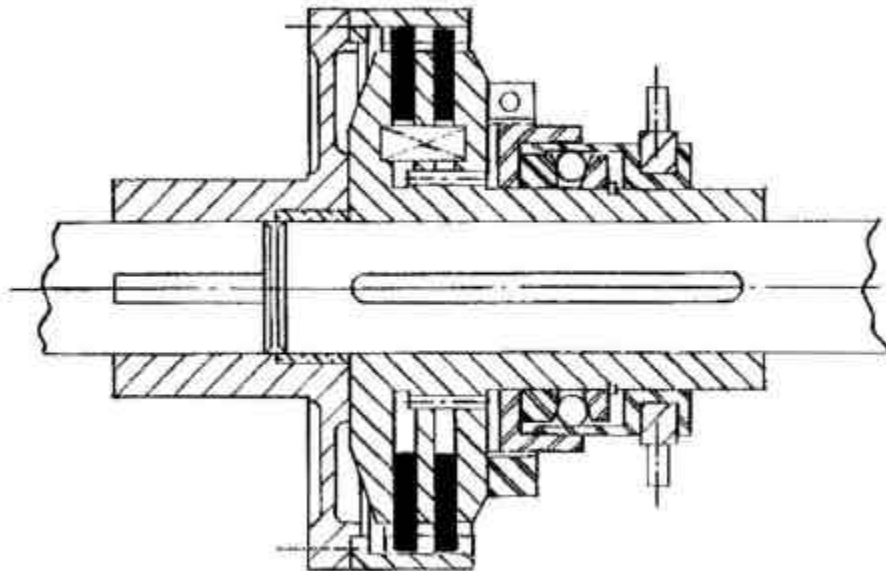

Figure 30(b)

25. FRICTION CONE CLUTCH

A cone type of friction clutch is shown in figure 31.

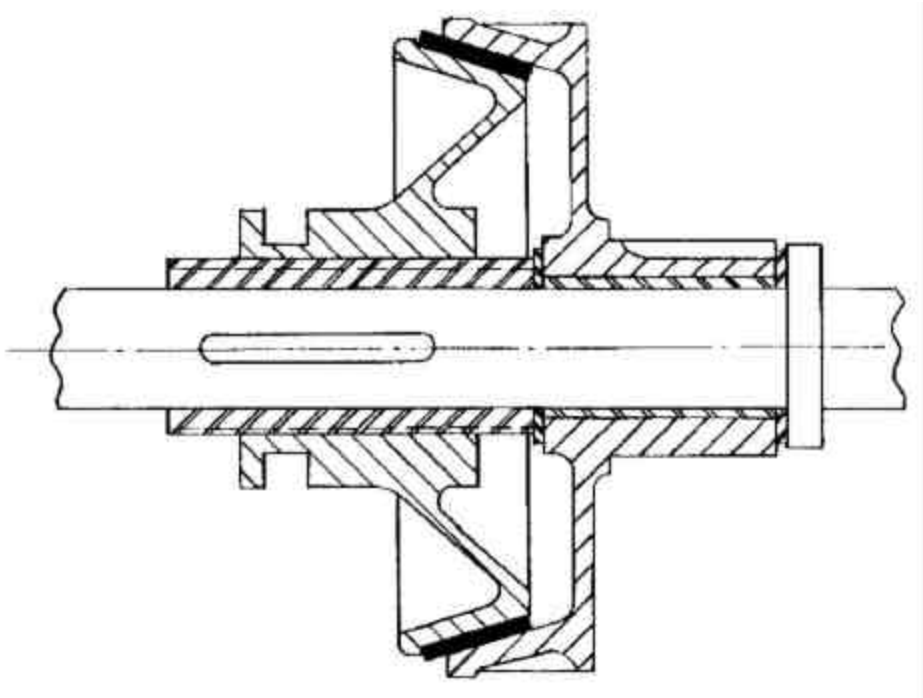

Figure 31

Because of the conical shape of the friction surfaces, a relatively small axial force applied to the inner member or cone, provides a large force normal to the friction surfaces. Thus it is seen that a relatively small axial force is all that is needed to engage a cone clutch.

Furthermore, if the cone angle is small enough, the friction surfaces will hold themselves together once the clutch has been engaged.

It follows that the elaborate linkage required with the disk clutch is not needed with the cone clutch, thus giving the cone clutch the advantage of simplicity. However, the cone clutch cannot be made in multiple units as can the disk clutch, a disadvantage of the conical construction.

26. CLUTCH OPERATING LINKAGE

Clutches are commonly engaged and dis-engaged by hand. In such cases a suitable linkage must be provided, generally resulting in some form of lever or handle which is readily accessible to the operator. This linkage must exert an axial force on the engaging sleeve while the sleeve is rotating.

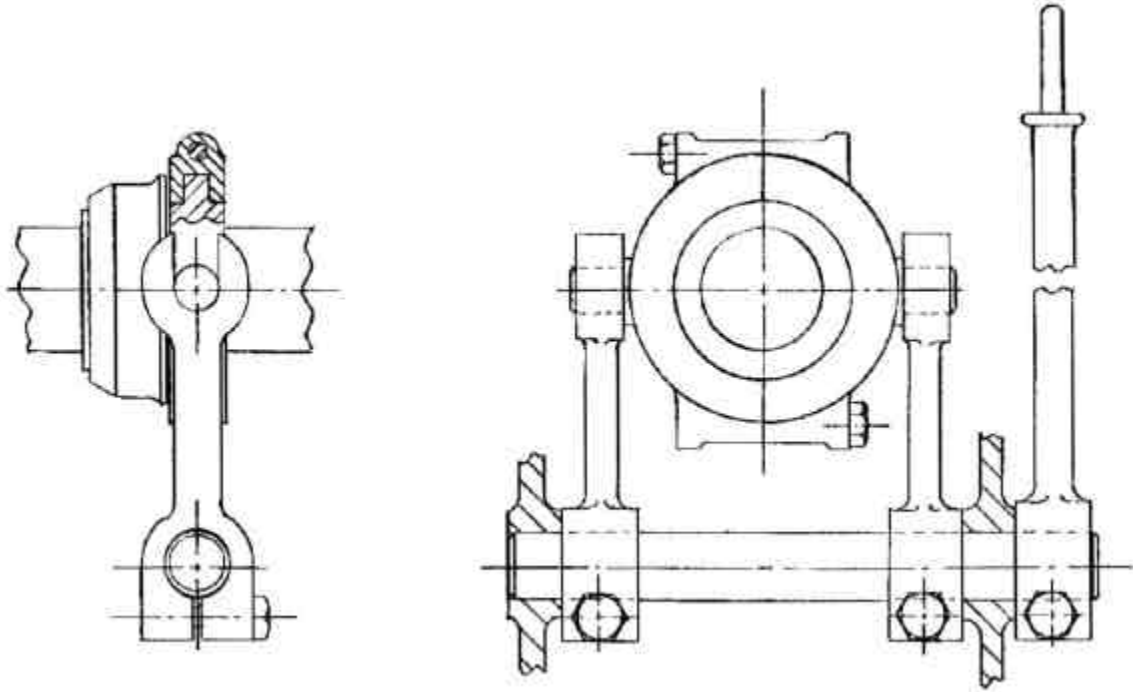

Figure 32

One method of doing this is shown in figure 32. Notice that a bearing ring, called a "throw-out" bearing, has been added to the engaging sleeve. This bearing ring, which contains two pins extending radially outward and located 180 degrees apart, is stationary, sliding on the sides of the groove in the engaging sleeve.

A fork and lever linkage as shown can be used to exert an axial force on the throw-out bearing pins, thus exerting a force on the engaging sleeve to operate the clutch.

On positive acting clutches and on cone clutches, the throw-out bearing is mounted directly on the clutch in the groove provided for this purpose, no engaging sleeve being necessary.

The sliding throw-out bearing shown in figure 32 is satisfactory if engagements and dis-engagements are relatively infrequent. For more severe service, a ball bearing should be used as shown in figure 33.

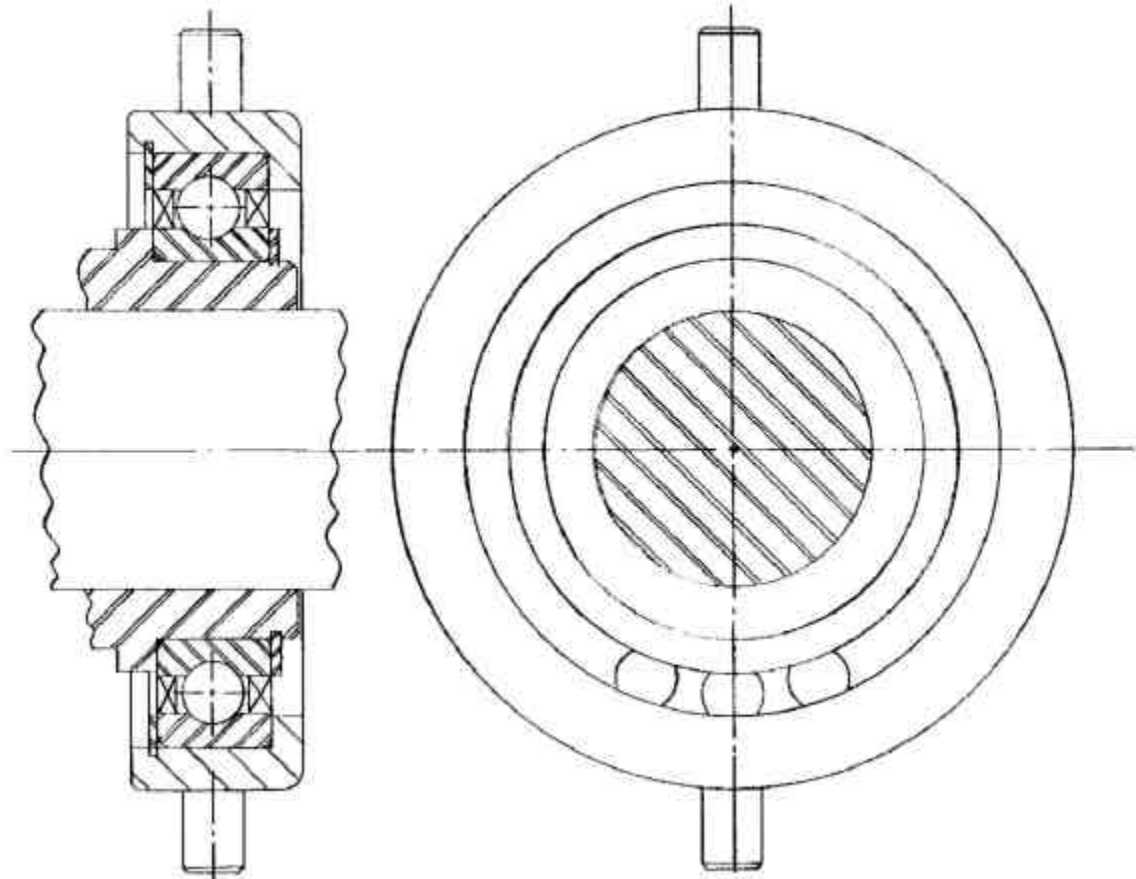

Figure 33

In any case, the entire clutch operating linkage must be so designed that a force is not exerted continuously on the throw-out bearing to hold the clutch in engagement. This causes premature failure of the throw-out bearing and is never a satisfactory construction.

27. POWER ACTUATED CLUTCHES

Clutches can be also actuated by air, hydraulic, or electric power instead of by hand. Because of the relatively large forces involved, air and hydraulic power are best suited to this service.

An air or hydraulic cylinder can be used to operate the handle shown in figure 32, and in such a case the linkage is very much the same as that used for manual operation.

Allowing the air or hydraulic fluid to act directly on the clutch disks is another method of power actuation and eliminates all the linkage. Figure 34 shows an air actuated clutch of this type.

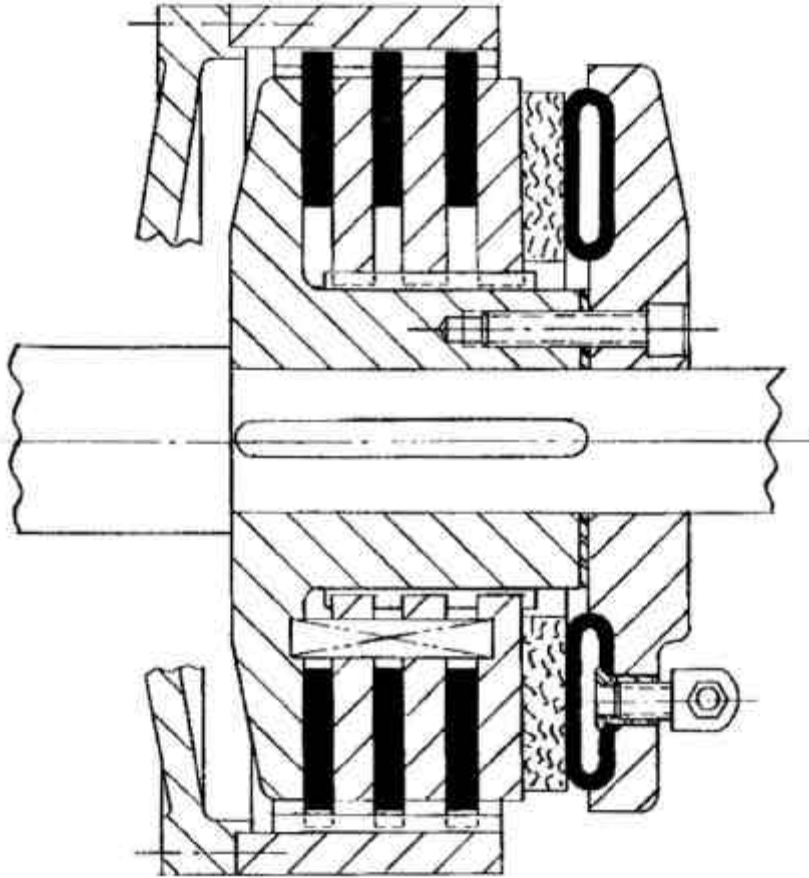

Figure 34

28. OVER-RUNNING CLUTCHES

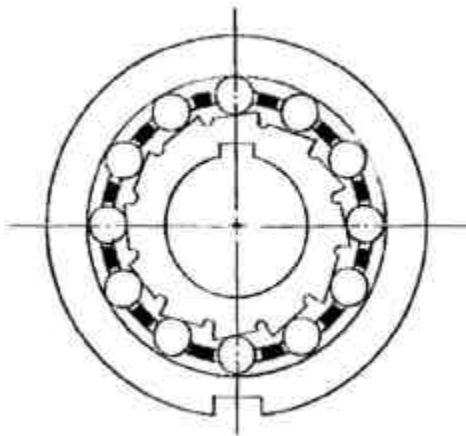

Figure 35

An over-running clutch of the roller ratchet type is shown in figure 35. This clutch can transmit torque in one direction only, hence is often called a "one direction" clutch.

Notice that the internal part can drive the external part in a counter-clockwise direction by virtue of wedging the rollers between the inner and the outer parts. The inner part cannot drive the outer part in a clockwise direction however.

Notice also that if both parts are turning counter-clockwise, the outer part can go faster than the inner part or "over-run" the inner part. The outer part, however, cannot go slower than the inner part.

The over-running clutch presents an interesting example of a friction clutch which cannot slip, hence is a positive acting clutch.

CHAPTER IV

BRAKES

A brake is a friction device used to prevent rotation or to reduce the speed of rotation of machine parts. Most brakes are friction devices, the work done by the friction force being used to absorb the energy of the rotating machinery.

29. EXTERNAL SHOE BRAKES

An external shoe brake consists essentially of a drum mounted on the shaft to be stopped, two or more shoes that press radially inward on the external surface of the drum, and a suitable lever system to apply and release the shoes. Two brakes of this type are shown in figures 36(a and b).

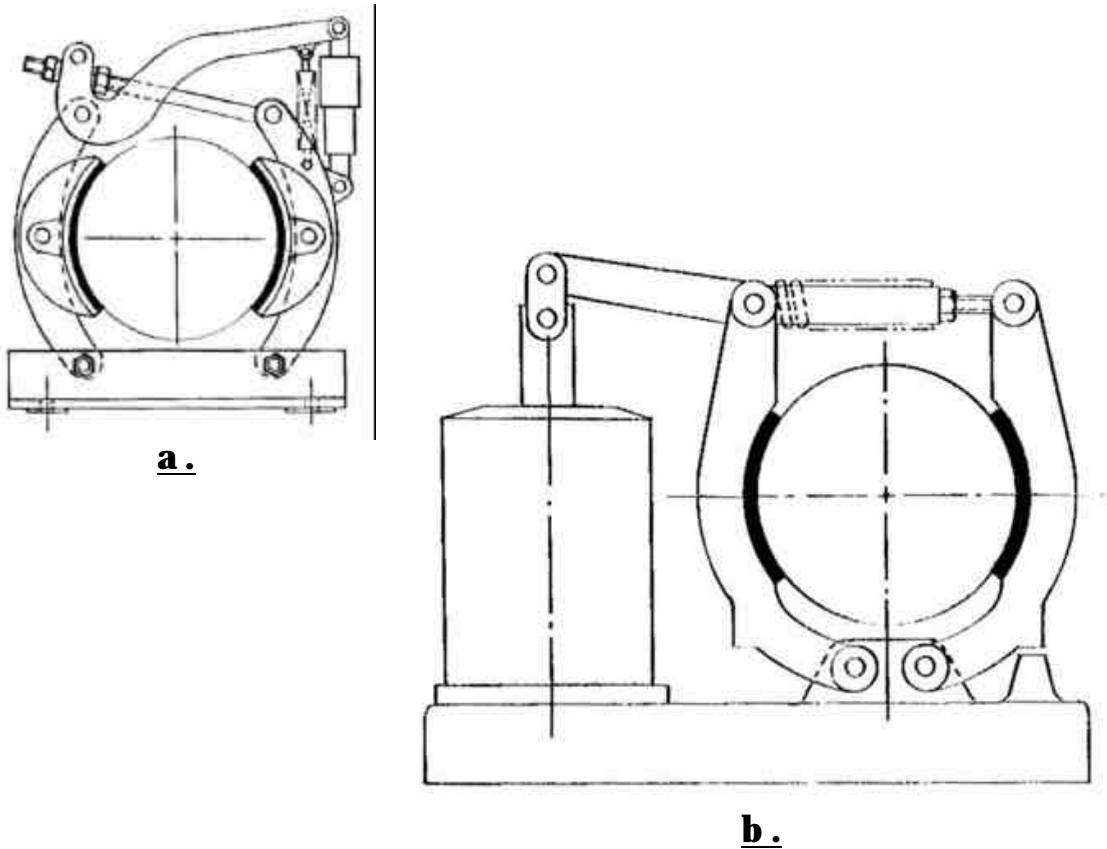

Figure 36

The brake shown in figure 36(a) is hydraulically applied and spring released. The shoes are pivoted on the brake arms in what is often called a "floating" shoe construction.

The brake in figure 36(b) is spring applied and released by the electric solenoid. This brake does not have the "floating" shoes of figure 36(a), but instead has shoes integral with the operating levers.

The shoe construction is not influenced by the method of applying and releasing the brake. The two different shoe constructions shown in figures 36(a and b) could be used with any method of operation. The integral brake shoe construction is generally the more simple of the two shown. However, the "floating" shoe construction does not require such careful alignment between drum and shoe assemblies, thus making installation more simple.

The external shoe brake is equally effective in either direction of rotation and lends itself to a simple, rugged construction. The brake drums should be made of "Cannonite" cast iron which has been developed especially for this service.

An adjusting device must be provided to compensate for wear of the shoes. This should be designed to allow locking securely in place after the adjustment has been made.

The shoes are commonly lined with a molded asbestos compound brake block, which is fastened to the shoes with brass bolts in countersunk holes. Thus the shoe lining can be quite readily replaced.

When the brake is released, it is possible for one shoe to bear tightly against the drum while the other shoe does all the moving. Means must be provided to cause both shoes to move away from the drum, and this is generally accomplished by providing stops to limit the travel of the shoes.

Ample size pins should be used throughout the brake linkage so as to provide low bearing pressure and long life. Pins should be hardened and ground and fitted with grease fittings to permit lubrication.

Another construction of a spring operated solenoid released brake is shown in figure 37. In this case the solenoid is mounted on the brake arm resulting in a compact installation.

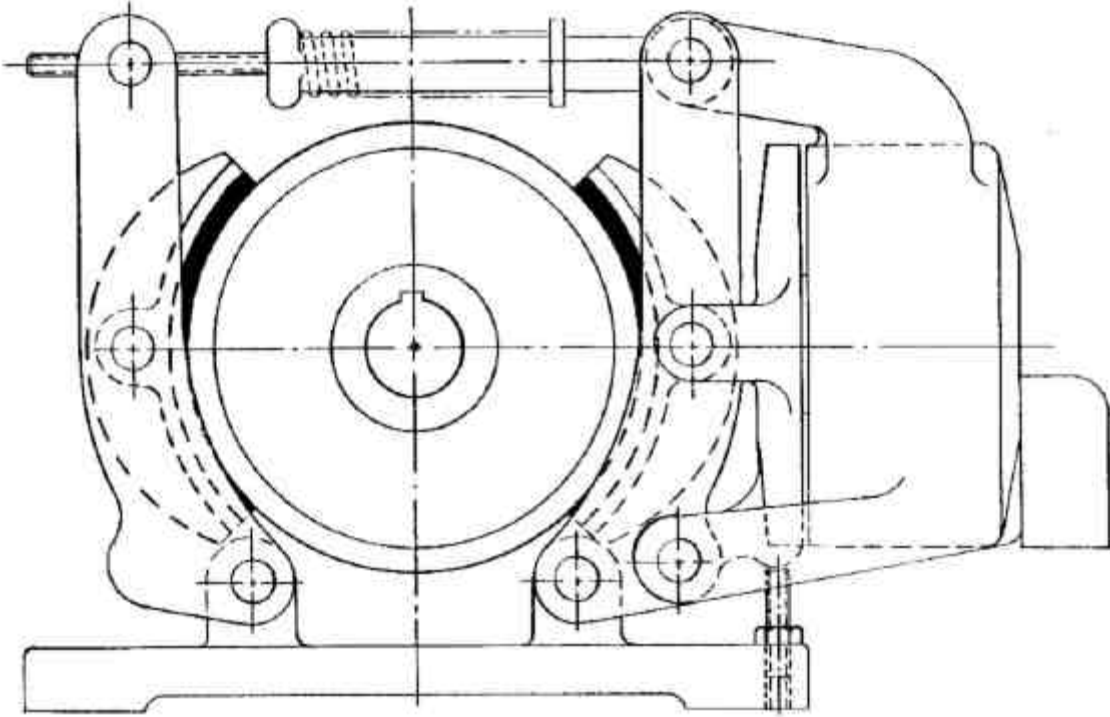

Figure 37

On punch presses and similar machines, a shoe brake is often used to drag constantly on the operating mechanism so as to have it coast to a stop in the correct position for the next operation. A brake of this type sometimes used for this service is shown in figure 38.

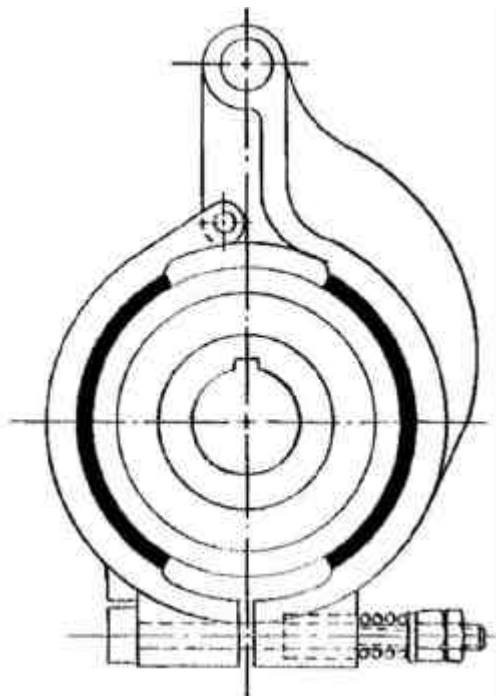

Figure 38

30. INTERNAL SHOE BRAKES

Placing the shoes inside the drum, as shown in figure 39, results in a brake that is self-energizing or will help to apply itself.

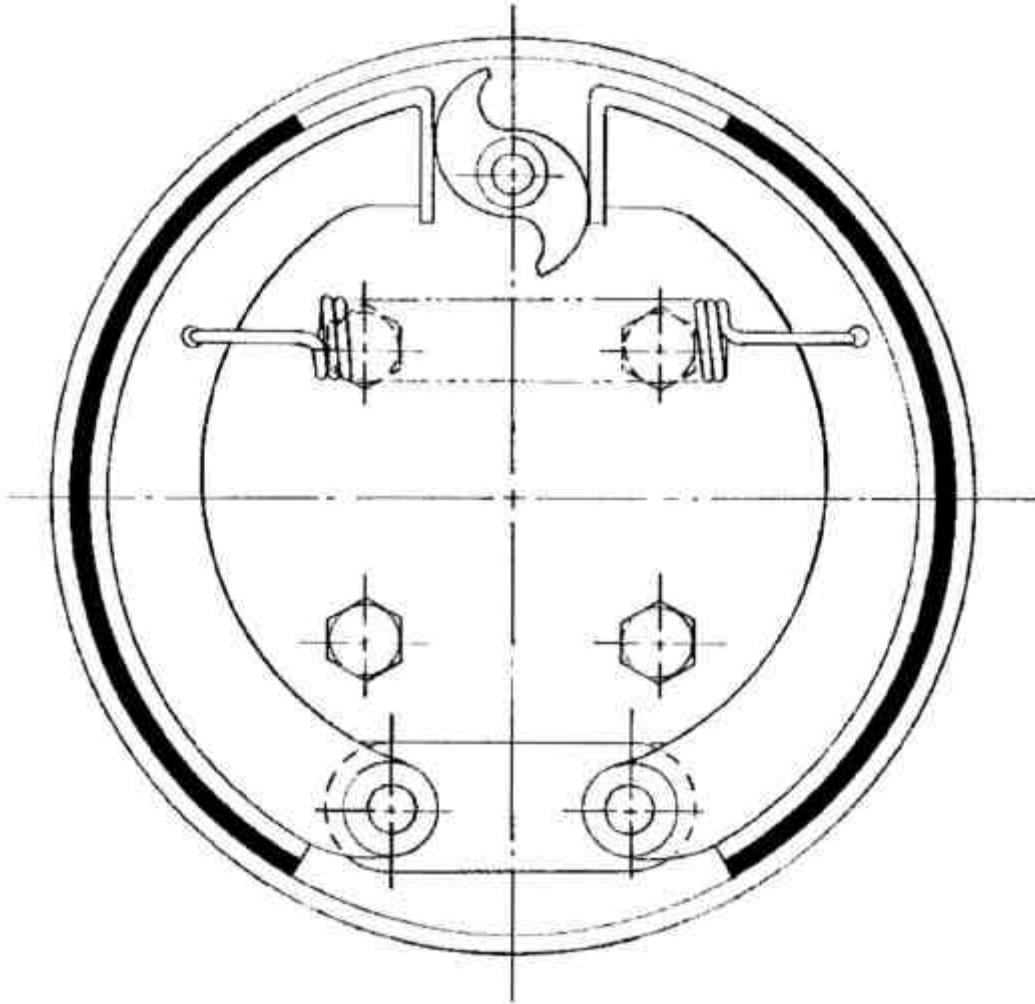

Figure 39

This arrangement can produce a large braking force by the application of a relatively small force at the shoes and has the added advantage of enclosing the shoes to keep out dust, water, etc. On the other hand, the size of the shoes and operating linkage are restricted because they all must fit inside the brake drum, and it is more difficult to dissipate the heat generated during the braking period.

The same lining materials that are used for the external shoe brakes are commonly used. The shoes should be made somewhat flexible to allow them to conform to the shape of the drum.

Internal shoe brakes are commonly used on vehicles. A single anchor, full floating brake used on a passenger car is shown in figure 40.

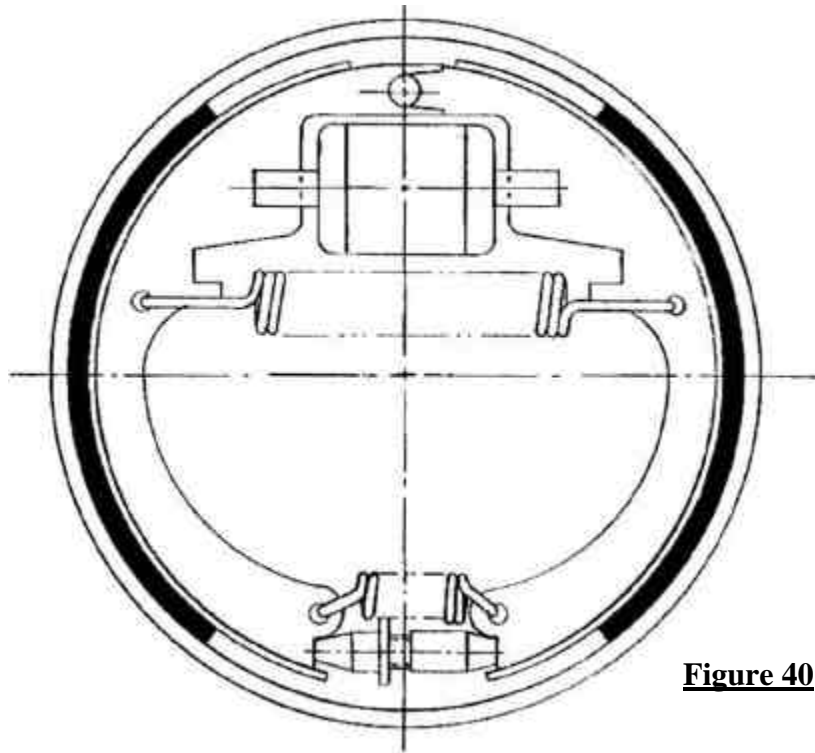

Figure 40

31. BAND BRAKES

Band brakes are not as commonly used as shoe brakes, but in some installations they have advantages over the shoe brake.

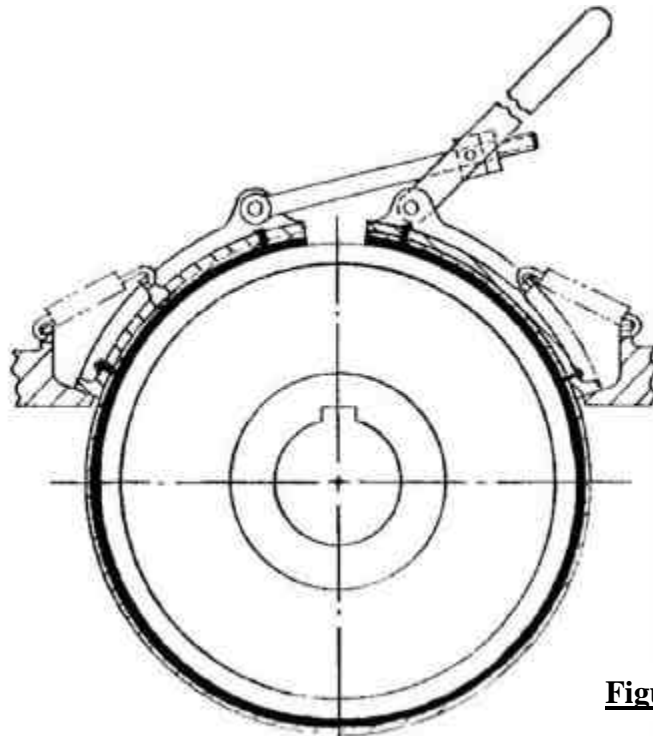

Figure 41

Figure 41 shows a band brake installation utilizing manual operation. The band brake is well adapted to this type of operation, and at the same time requires but little space beyond the outer diameter of the drum. The operating linkage is pinned to the band but is not fixed to any support, hence anchor supports are provided on the band to keep the entire brake assembly from rotating with the drum.

As with shoe brakes, ample size hardened pins equipped with lubrication fittings, should be used in the linkage. The band is commonly made of steel to which the lining is riveted. Folded asbestos fabric lining is commonly used for band brakes.

It is apparent from figure 41 that the band brake is more effective with one direction of rotation than with the other direction of rotation. In some cases, advantage can be taken of this feature by designing the linkage in such a way that the brake will release itself when the drum turns one direction and will apply itself when the drum rotation reverses. This can be used to prevent reverse rotation in a machine.

The band brake can be power actuated by adding a solenoid, air cylinder, or hydraulic cylinder to the operating linkage. A hydraulically operated band brake is shown in figure 42.

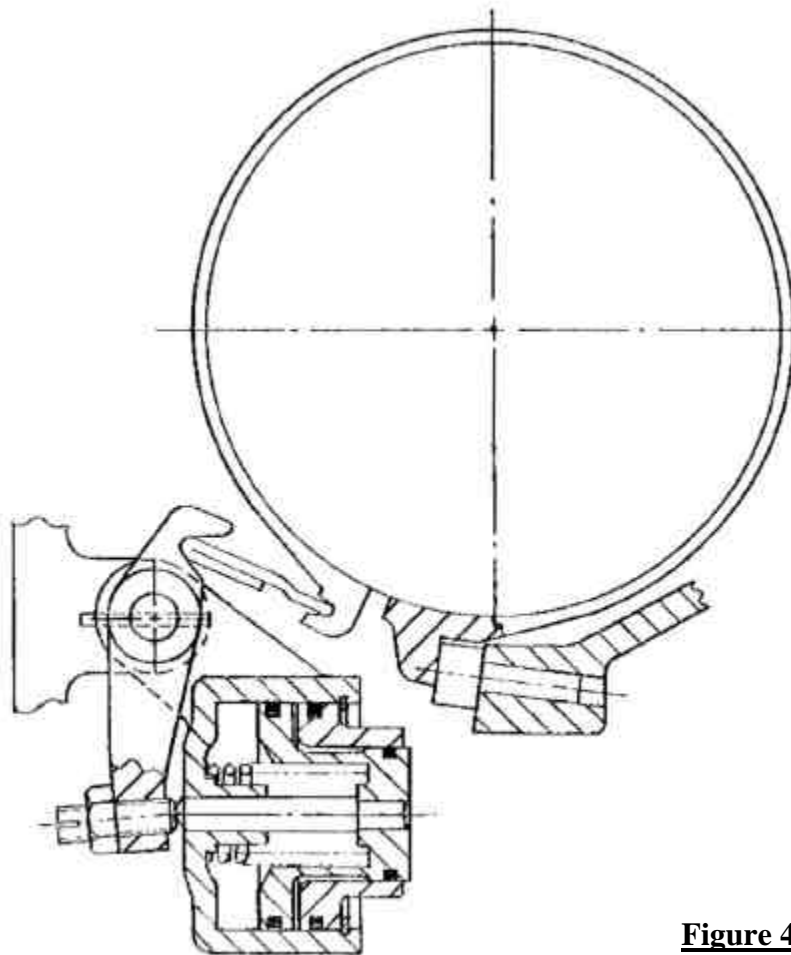

Figure 42

This brake is designed to operate in oil, hence the band is lined with sintered bronze rather than asbestos. The band can be made of either steel or cast iron.

Band brakes can also be used as lowering brakes on cranes by providing a torque-responsive linkage that will apply the brake just enough to absorb the energy of lowering. This provides a constant lowering speed.

Band brakes can also be used as drag brakes on presses in very much the same way shoe brakes are used. A band type of drag brake is shown in figure 43. A screw at the end of the lever provides adjustment of the amount of drag.

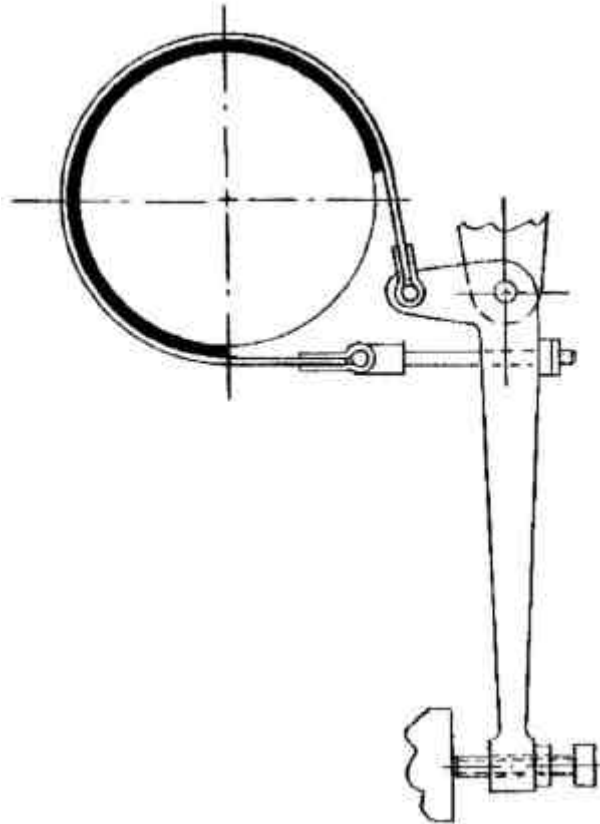

Figure 43

32. DISK BRAKES

Disks can be used as a brake in very much the same construction as was used for the disk clutch. A disk clutch and brake can be combined into one unit, and this construction is commonly used on mechanical punch presses. The clutch disks engage the crankshaft to perform the punching operation, and the brake disks stop the crankshaft when the clutch is released. Operation by compressed air, utilizing a construction somewhat similar to that shown in figure 34, is fairly common in these combination disk clutch and brake units.

Disk brakes can be designed to be self energizing so that they tend to apply themselves. Brakes of this type have been applied to automobiles.

CHAPTER V

SPEED AND DIRECTION CHANGING DEVICES

Many machines must be capable of operating at various speeds, often times in either direction of rotation. Mechanical speed and direction changing devices are commonly used in such a case. Several such devices are described in the following paragraph, some of them providing speed changes in definite steps, others being infinitely variable.

33. GEAR UNITS

A fairly common method of obtaining more than one speed in a machine is to incorporate a gear drive with one or more sliding gears, such as shown in figure 44.

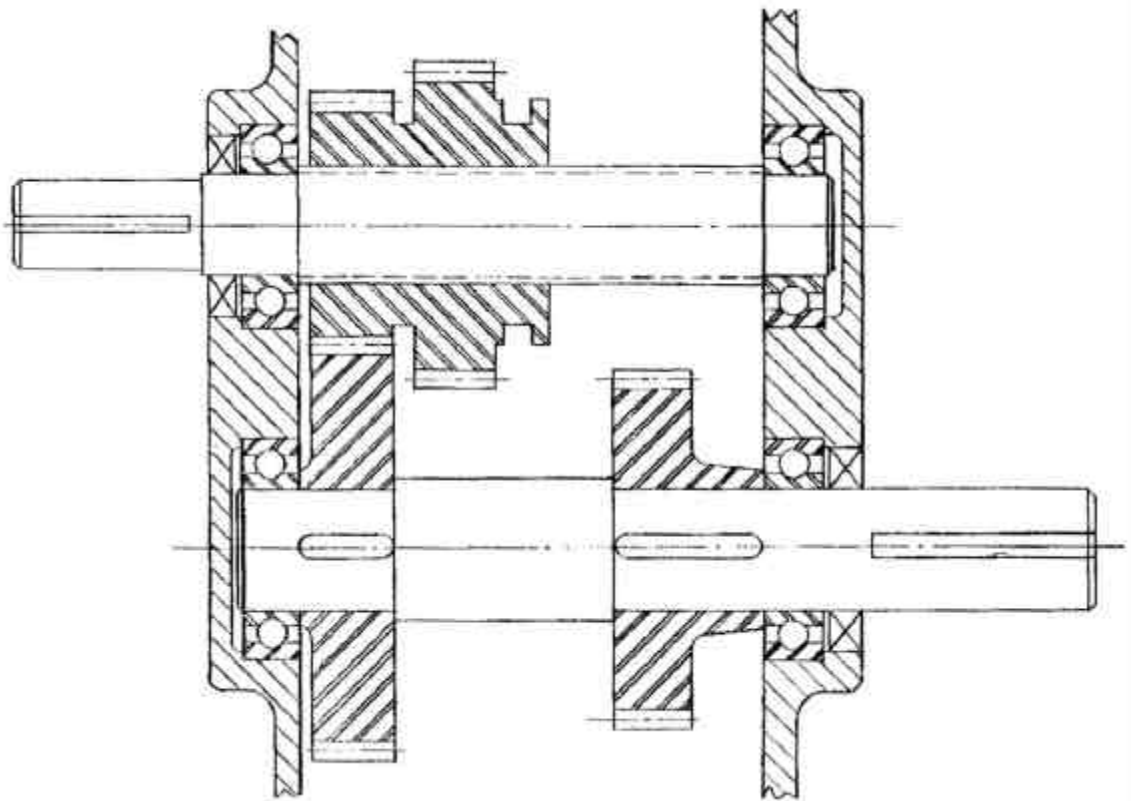

Figure 44

By shifting the double gear on its splined shaft, two speeds are obtained from a single input speed by the construction shown in figure 44. If a third gear is added to the output shaft, and a reverse idler is provided as shown in figure 45, reverse rotation can be obtained also.

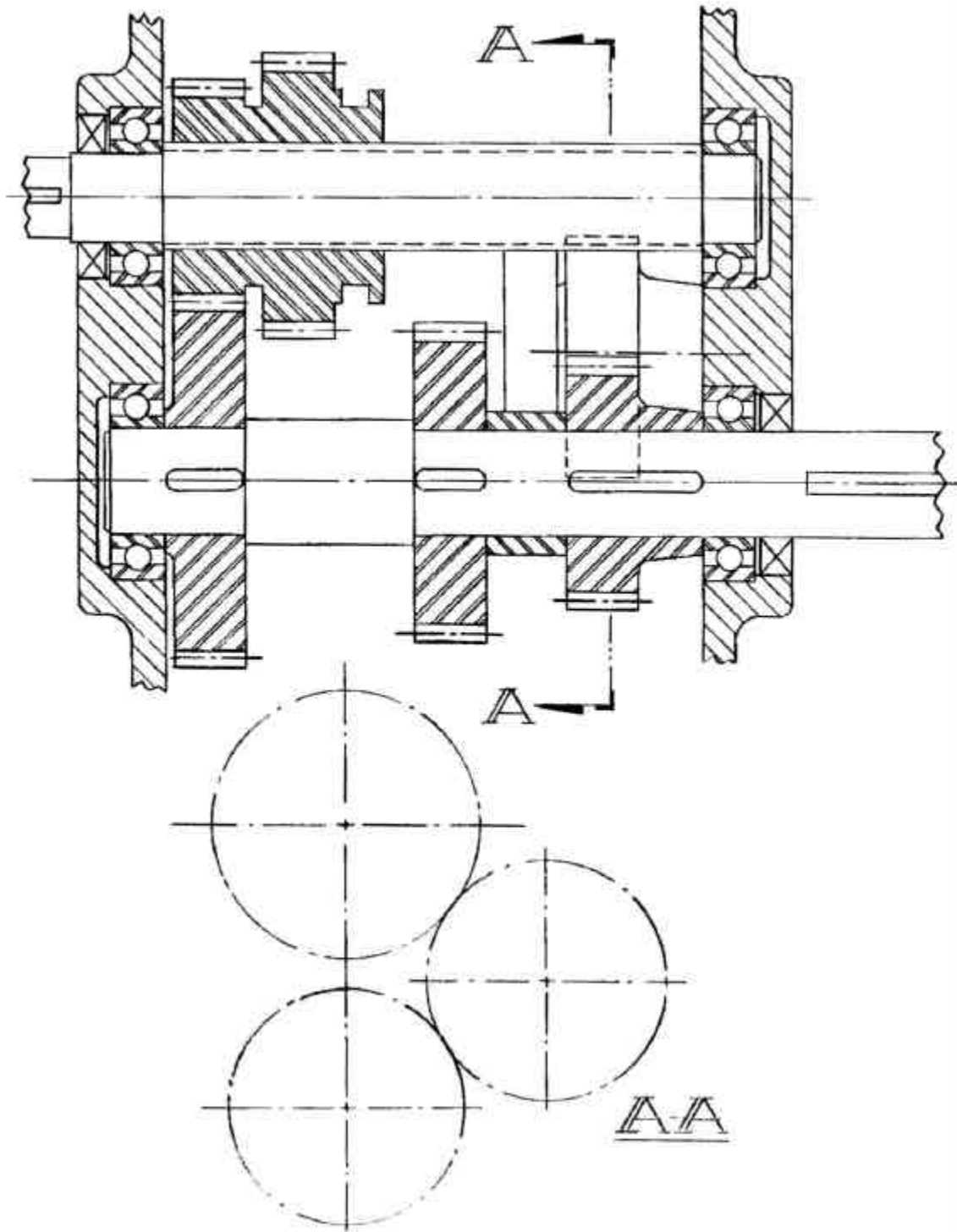

Figure 45

Sliding gear units as shown in figures 44 and 45 lend themselves to relatively simple and durable construction and are used quite commonly. Care must be taken to space the gears axially so that the sliding gear cannot possibly be engaged in two speeds at the same time. The splines in both the gear and shaft must be carburized or similarly case hardened, and the shaft should be generously proportioned to prevent the gear and shaft from binding during the shifting operation.

The shifting groove diameter must be large enough to leave a fairly thick section of metal between the bottom of the groove and the splines. Otherwise this section will warp during the heat treating process. This warpage causes the gear to set unevenly on the shaft, and it will then often work its way out of engagement as the machine operates.

The construction shown in figures 44 and 45 becomes cumbersome if very many speeds are required, the shifting gear tending to become large and unwieldy. Furthermore, if helical gear teeth are used instead of spur gear teeth, it is difficult if not impossible to use a multiple shifting gear as shown in figures 44 and 45. Helical gears must be shifted on a helical spline to cancel out the thrust on the gear teeth. It is not often possible to have a common spline balance out the thrust of two different size helical gears unless the two gears have radically different helix angles.

Figure 46 shows another method of obtaining two speeds, but in this case a splined clutch is shifted rather than the gear. This construction works equally well with either spur or helical gears since the clutch slides on straight splines.

If a friction clutch, similar to that shown in figure 30(a), is used instead of the spline clutch shown in figure 46, it is possible to shift from one speed to another while the machine is in motion. The friction clutches generally require much more space than the spline clutch, thus the compactness inherent in the spline clutch design is lost.

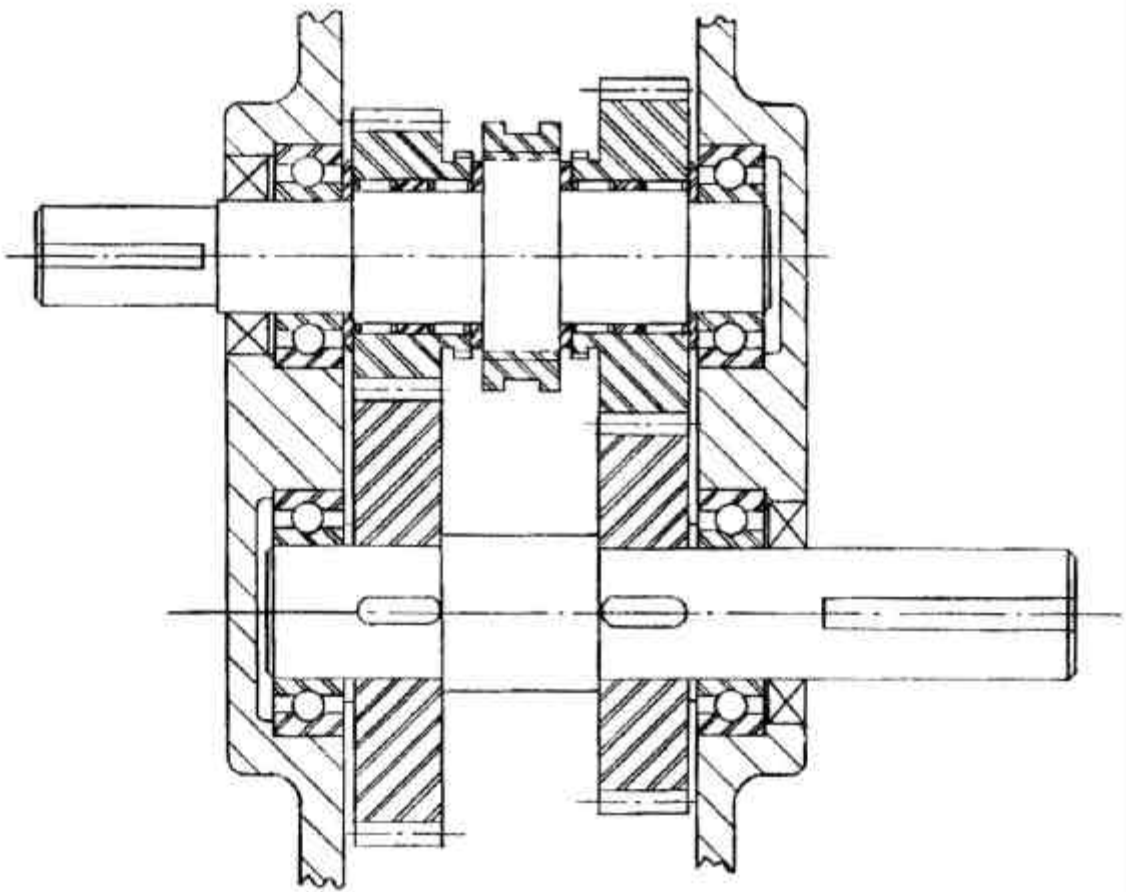

Figure 46

Figure 47 shows an over-running or one direction clutch used with a spline clutch to obtain two speeds with but one shifting operation.

When the spline clutch is engaged, the one direction clutch over-runs, while if the spline clutch is dis-engaged, the one direction clutch immediately starts driving. A friction clutch can be used in place of the spline clutch, but in either case there is no neutral or dis-engaged position.

Although figures 46 and 47 show gear units, these same constructions can also be used with roller chains and sprockets or with V-belts and pulleys.

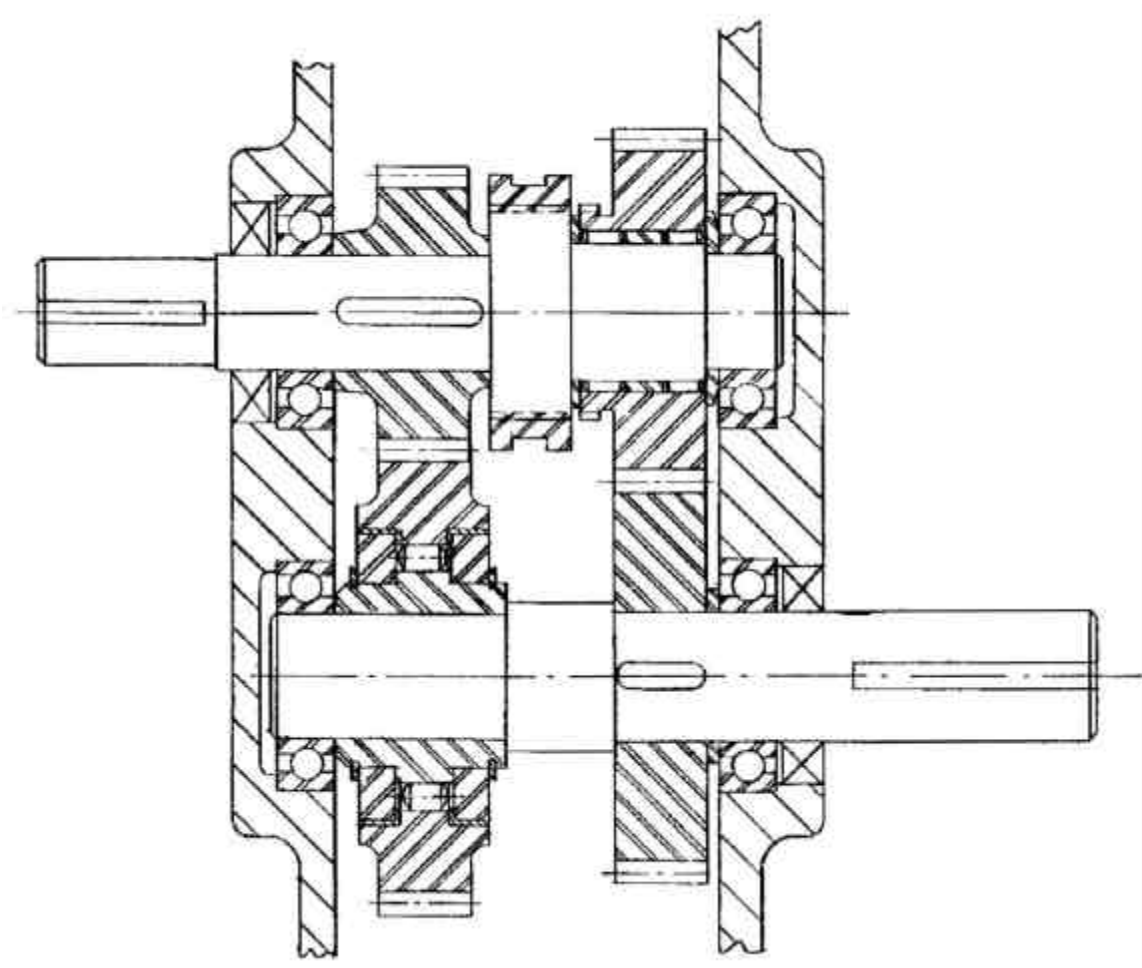

Figure 47

In the interests of economy and compactness, a gear can often be used as a clutch. Figure 48 shows a two speed unit, both speeds being obtained by shifting a single gear and having this gear perform as a spline clutch also.

Notice that with this construction, a direct drive is obtained by shifting the gear to the left while a double reduction results when the gear is shifted to the right.

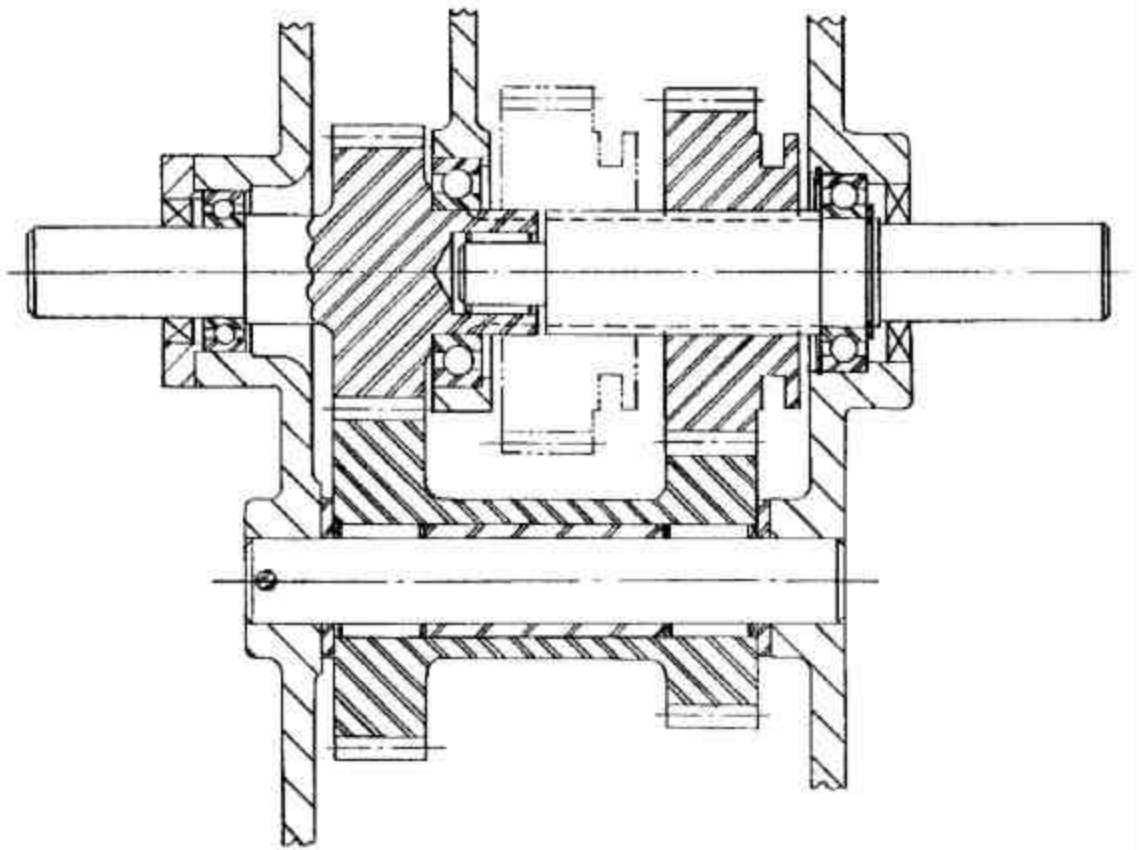

Figure 48

A bevel gear reversing unit is shown in figure 49. Either spline clutches or friction clutches can be used. The construction shown provides exactly the same speed ratio in each direction of rotation.

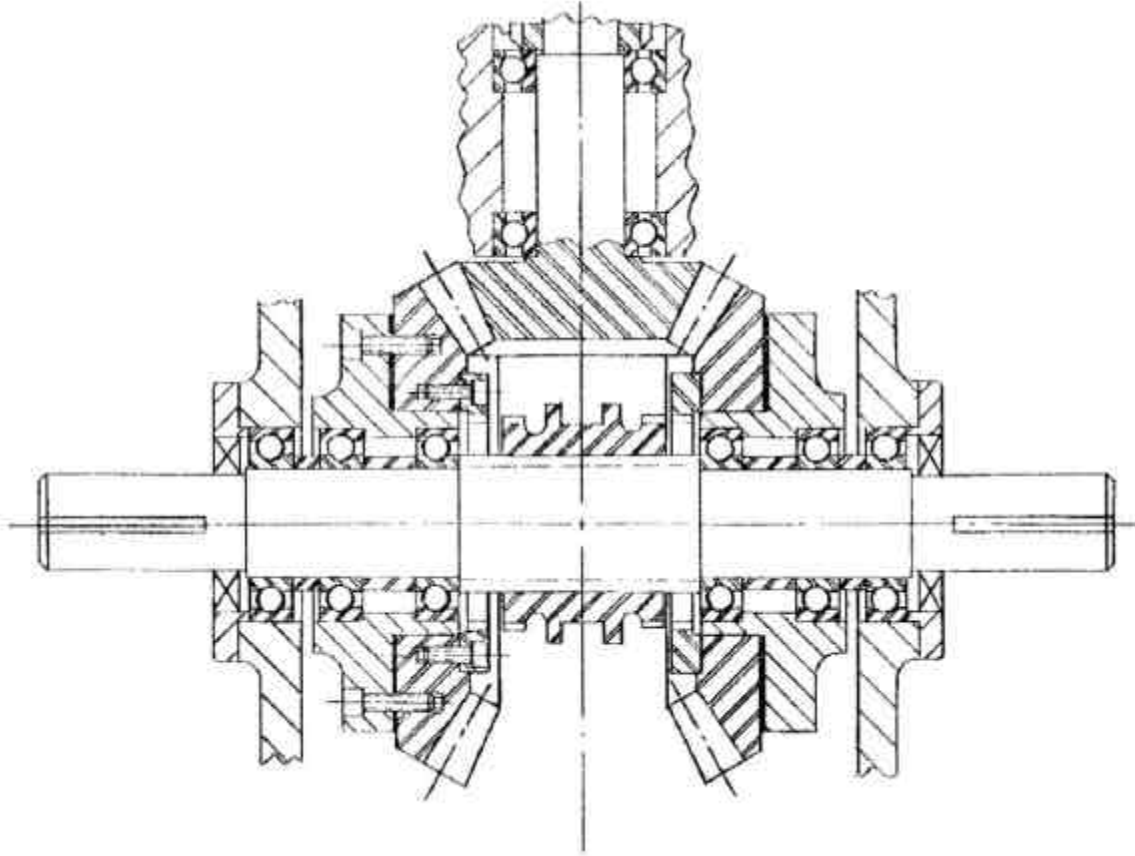

Figure 49

Multiple speed units can also be obtained by the use of planetary gearing. The planetary construction has the advantage of allowing speed changes while the parts are moving or even while transmitting power. The construction can be easily adapted to automatic operation by the use of pneumatic, hydraulic, or electrical actuating devices. Since the gear forces cancel one another, the shafts and bearings of the planetary units can often be made much smaller than in sliding gear or clutch units.

However, the planetary construction is always more intricate and more expensive than the more conventional gear units. Furthermore, there are certain ranges of speed ratios which cannot be obtained with planetary gearing.

A simple planetary gear unit which provides a speed reduction and a neutral or dis-engaged position is shown in figure 50.

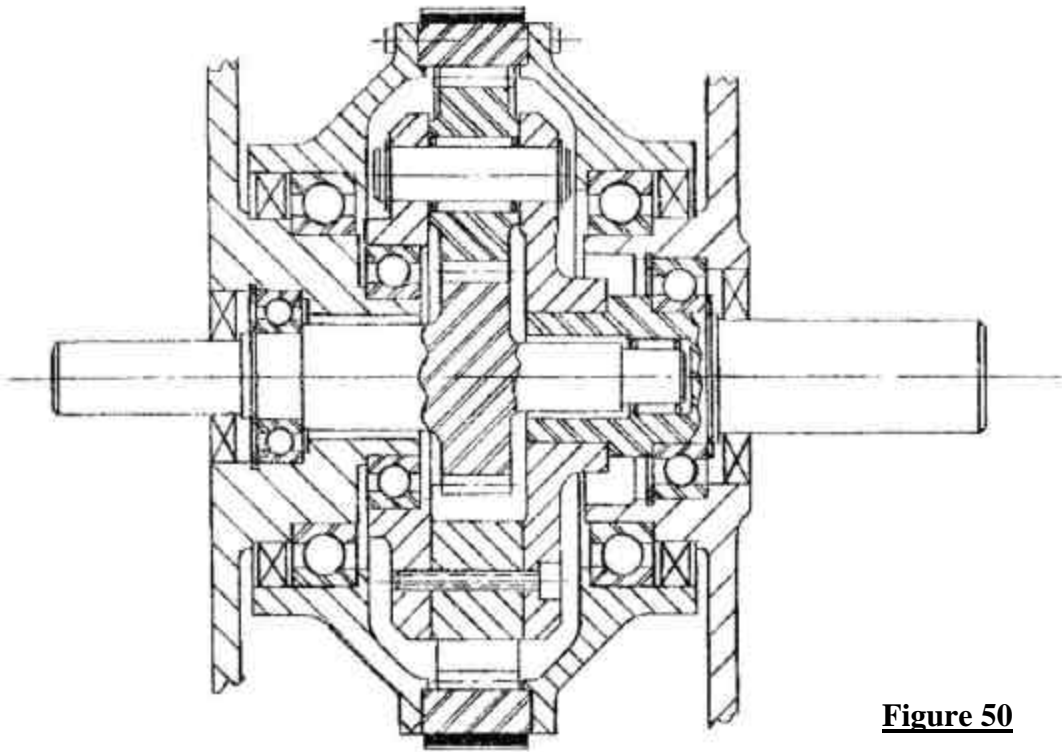
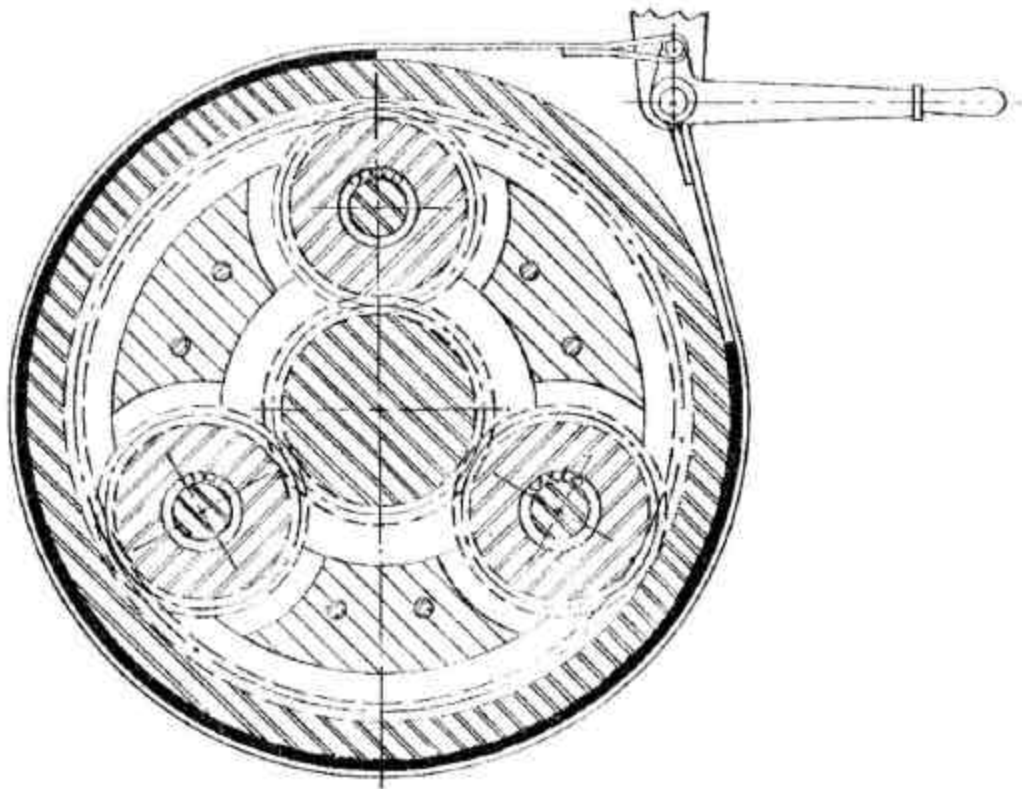

Figure 50



If the band brake of figure 50 is applied, the output shaft runs at a reduced speed, while releasing the brake allows the ring gear to turn freely while the output shaft remains stationary.

To balance the rotating assembly and to distribute the load, it is common to use two, three, or four planetary pinions. The pinion shafts and bearings are heavily loaded when the planetary unit is in operation, hence care must be taken to provide a substantial carrier to support these parts.

The necessity of supporting and enclosing all of the parts requires a rather elaborate and at times ingenious construction, as is evidenced by the planetary gear of figure 50. The complexity of construction increases when more parts are added to the planetary gear to provide more than one speed or a reverse. Nevertheless, the planetary is an exceedingly versatile device, and can be designed in many different combinations to provide a variety of speeds.

It is desirable to have the load divided equally between the planet pinions, but this generally will not happen unless special means are provided to bring it about. To help accomplish the equal load distribution, the load carrying members should be made somewhat flexible. However, this flexibility must not impair the action of the bearings, so reasonably substantial planet pins and planet carriers should be used.

34. FRICTION DEVICES

All of the devices shown above provided speed ratios in certain definite steps. By using a friction drive, it is possible to provide an infinitely variable output speed from a constant input speed. Many friction drives have been tried, but the V-belt drive with a variable size pulley is the most commonly used device. This type of variable friction drive is shown in figure 51 on the following page.

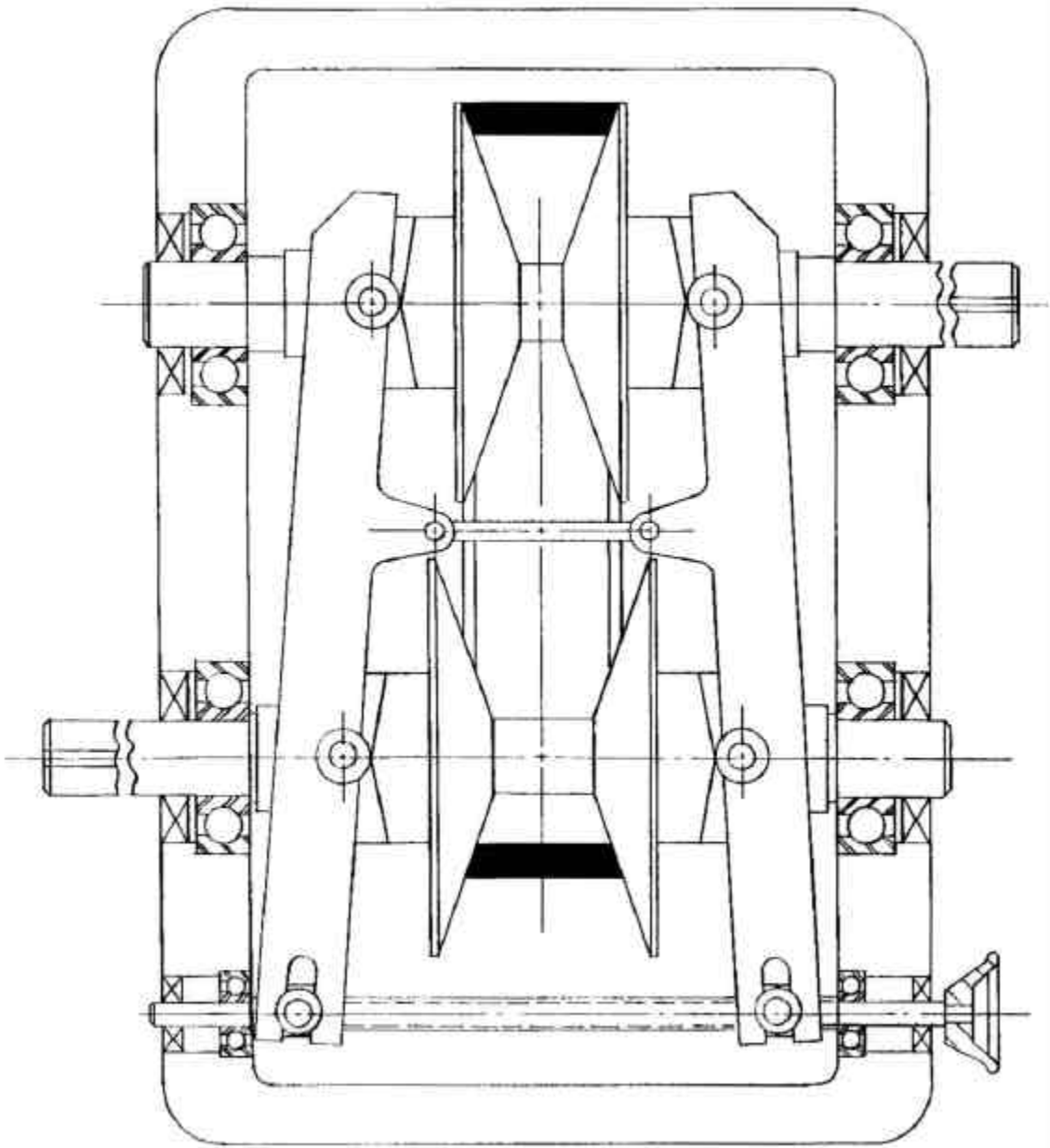

Figure 51

CHAPTER VI

MOTION CHANGING DEVICES

Motion changing devices of one sort or another are commonly used in machinery. This is largely due to the fact that most machines are driven by a rotary power source, such as an electric motor. If some motion other than rotation is required, a device must be designed which will provide the desired motion from the rotary motion of the power source.

35. CAMS

Cams and followers represent one of the common types of motion changers. Plate cams are the most commonly used type. They are capable of providing a variety of motions from a constant rotational driving speed.

Figure 52 shows a plate cam with several different types of followers. Notice that reciprocating or oscillating motion can be obtained on the follower, although the cam rotates at constant speed.

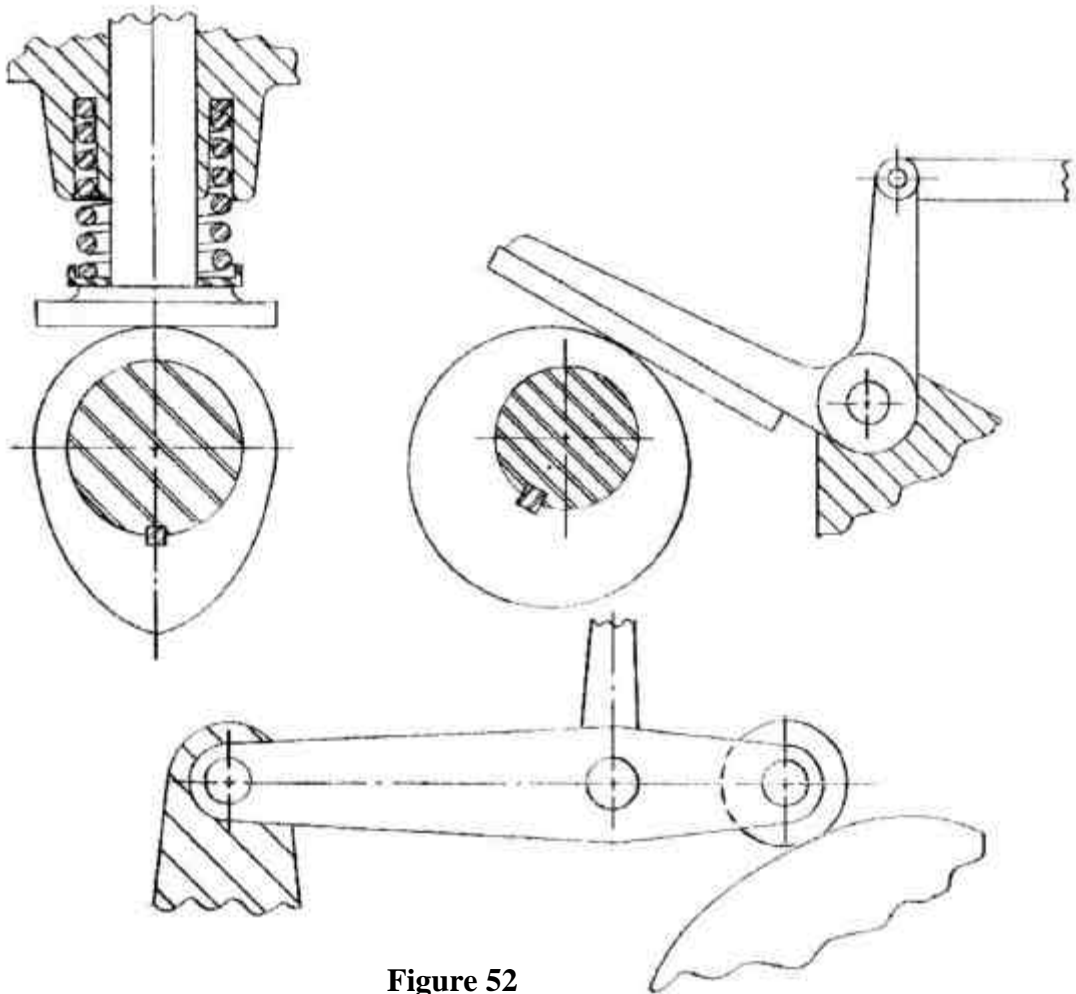

Figure 52

Both the flat-face followers and roller followers shown in figure 52 are commonly used. The roller follower is particularly useful for heavy loads at low speeds. Even at low cam speeds, however, the roller generally rotates at high speed and at the same time carries a heavy load. Because of this, care must be taken to provide ample bearing capacity for the roller.

The flat follower is commonly used for higher speeds and lighter loads. Sufficient cam width must be provided so as to distribute the load enough to prevent excessive wear on the sliding surfaces. Cam and follower surfaces should always be hardened and well lubricated to get reasonable wear life.

Both the cam and the follower must be well supported so as to hold their proper alignment. Otherwise the cam and follower will not be in contact all the way across the face of the cam, and premature failure will result.

36. CRANKS AND ECCENTRICS

A simple but effective method of converting rotating motion to reciprocating motion, or vice versa, is the slider crank mechanism, shown in figure 53.

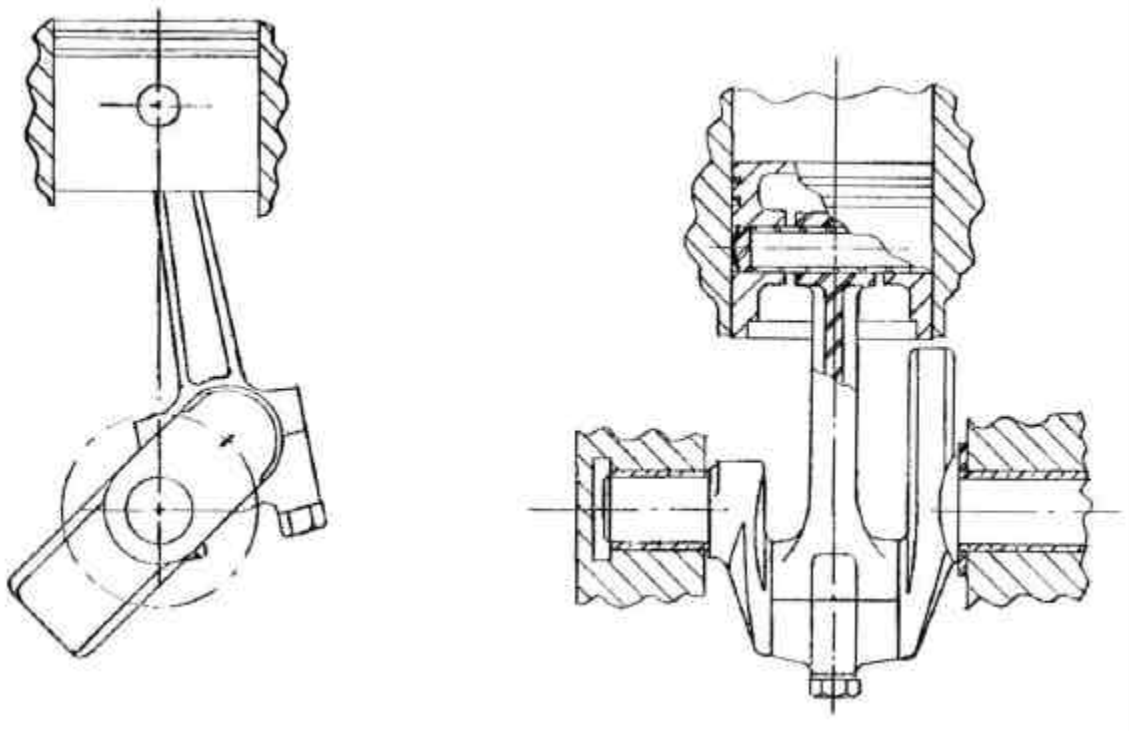

Figure 53

This same mechanism is used in many machines such as combustion engines, pumps, compressors and presses. It consists of four basic parts: crank, connecting rod, sliding member, and guide member. The crank is commonly made in one piece with main bearings on either side of the crank throw. In such a case the connecting rod and its bearing must be made in two pieces to allow assembly. Because of this, sliding bearings are commonly used between the crankpin and connecting rod.

The two pieces of the connecting rod are generally held together by two or more bolts. These bolts should be located as close to the bearing bore as possible and should have very substantial flanges on each piece of the rod.

A correct and incorrect connecting rod construction are shown in figures 54(a and b). The construction shown in 54(b) will allow the bolts to simply bend the flanges rather than pull the two pieces tightly together.

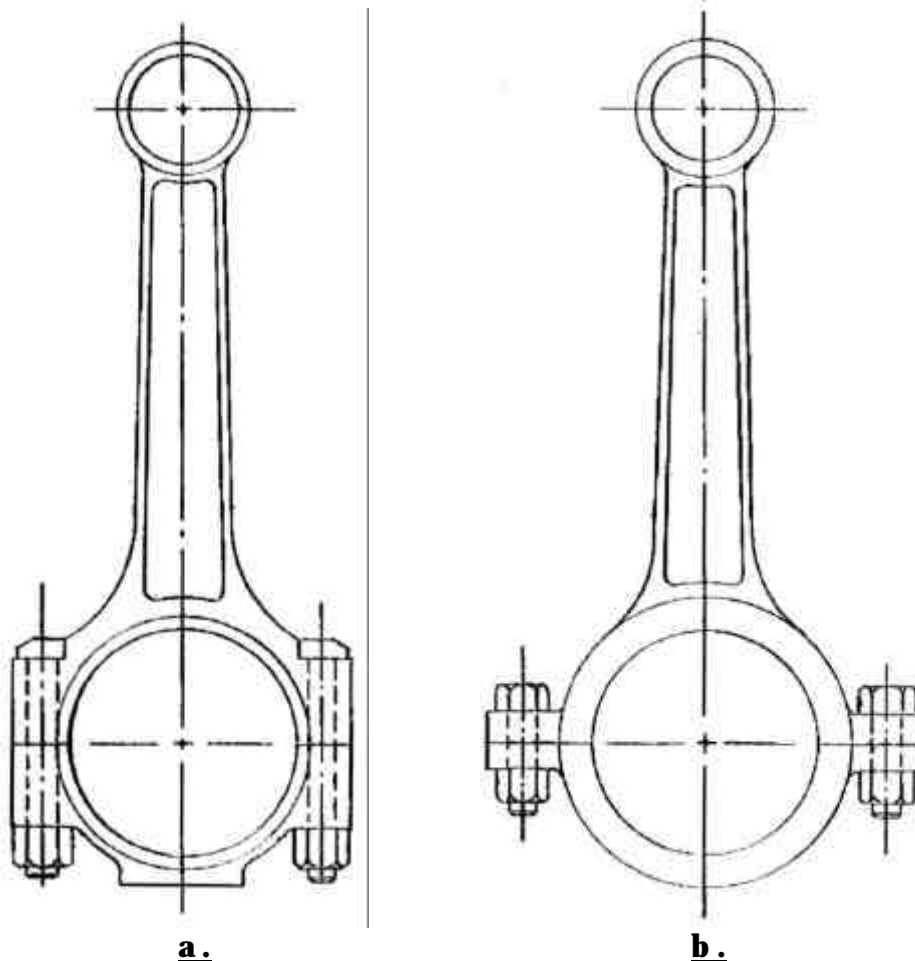

Figure 54

The sliding member must have ample length and substantial guiding members in order to obtain trouble-free operation. If the sliding member does not contact the guide members along a sufficient length of surface, the sliding member will "cock" and not move freely. This same is true if the guiding members are free to deflect under the load applied by the sliding member.

The crank rotates off center, hence is not a balanced device. At slow speeds this is of no concern. At higher speeds, however, the crank must be balanced by the use of counterweights as shown in figure 53.

If the crank is to be used for multiple cylinder high speed engines, a great deal of care must be given to the matter of proper balance.

An eccentric is used in very much the same way as a crank. Its construction is somewhat different, however, with an off center disc being substituted for the crank throw. Such a construction is shown in figure 55.

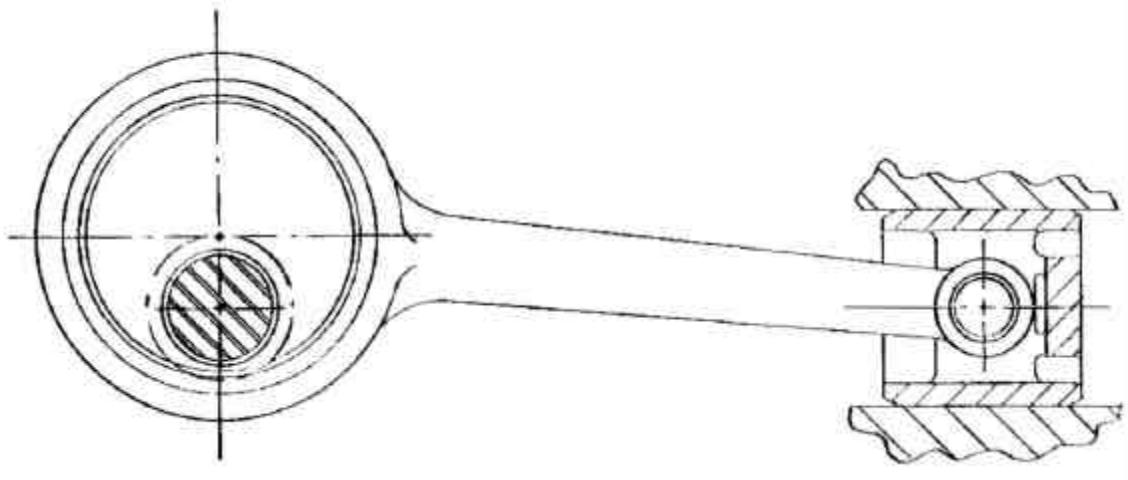

Figure 55

The eccentric construction often allows the use of a one piece connecting rod, but the whole assembly becomes large and cumbersome if a large throw is required. It is also more difficult to retain the rod axially with the eccentric than with the crank.

37. INTERMITTENT MOTION DEVICES

One of the oldest and simplest intermittent motion devices is formed by a driving gear with some of its teeth removed. Thus the driven gear is alternately driven and allowed to remain stationary as the driving gear turns at a constant speed.

This type of drive is satisfactory for only very light service at low speeds. Since this type of drive does not provide for gradual acceleration of the driven parts, the impact is large when the teeth first engage. Furthermore, a drag brake or similar device must always be provided to stop the driven machine instantly upon dis-engagement of the teeth and hold it stationary so that the teeth will be in the proper position for the next engagement.

The Geneva mechanism, shown in figure 56, is one of the best intermittent motion devices.

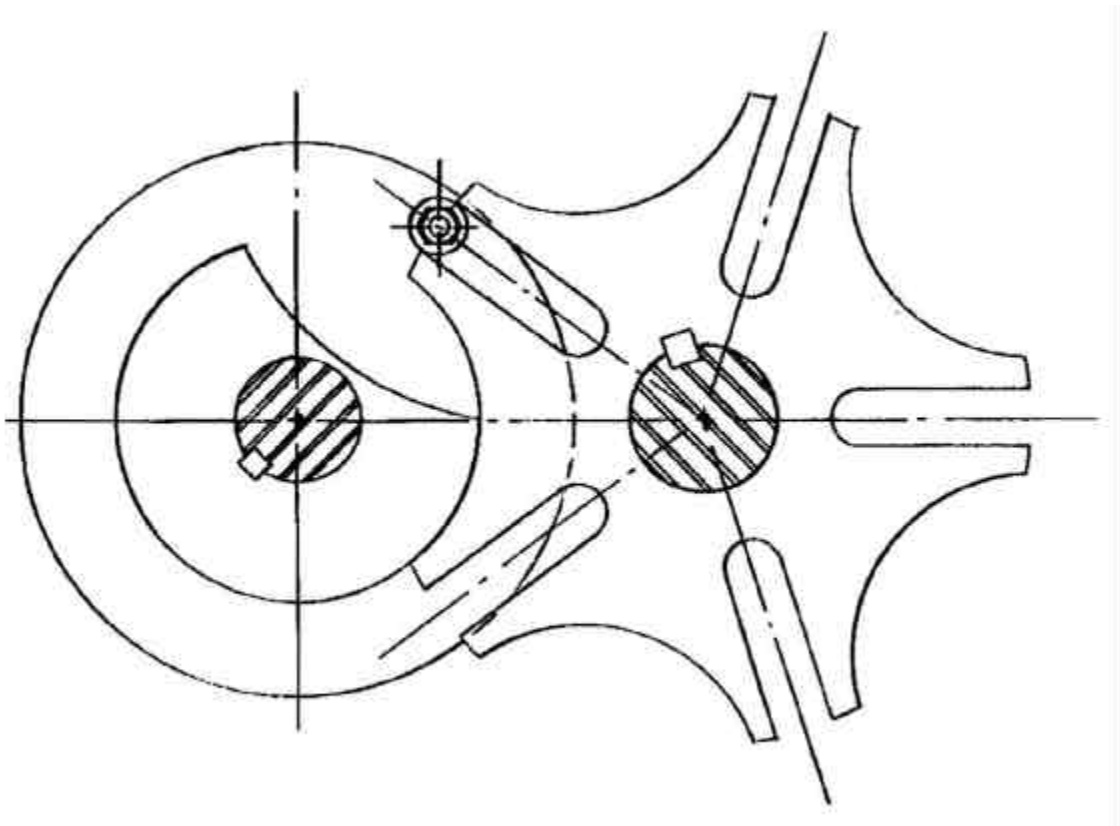

Figure 56

It delivers an intermittent rotation to the driven member and keeps the driven member from turning between the periods of engagement. The parts should be designed so that as the driving roller enters the slot, the center-line of the slot is tangent to the circle on which the roller is located. This allows engagement with a minimum amount of shock.

The roller pin and bearing of the Geneva Mechanism should be generously proportioned to carry the large loads commonly encountered. The rollers are commonly made of hardened steel while the slotted plate can be of steel or cast iron, depending upon the forces to be carried. Since the roller is often made of a harder material than the plate, both pieces should be considered when calculating the load carrying capacity of the two surfaces.

The Geneva Mechanism is commonly used as an indexing device in production machinery. In such a case, exact positioning of the driven member is often required while this part is stationary. Although the Geneva Mechanism will prevent rotation of the driven member during this time, it cannot hold it accurately enough for this type of service, hence an additional locating device must be used.

The Geneva Mechanism can be constructed with numerous variations from that shown in figure 56. Many of these variations are to be found in Mechanism or Kinematic texts.

Another intermittent motion device which gives much the same type of motion as the Geneva Mechanism is the Ferguson Roller Gear drive shown in figure 57.

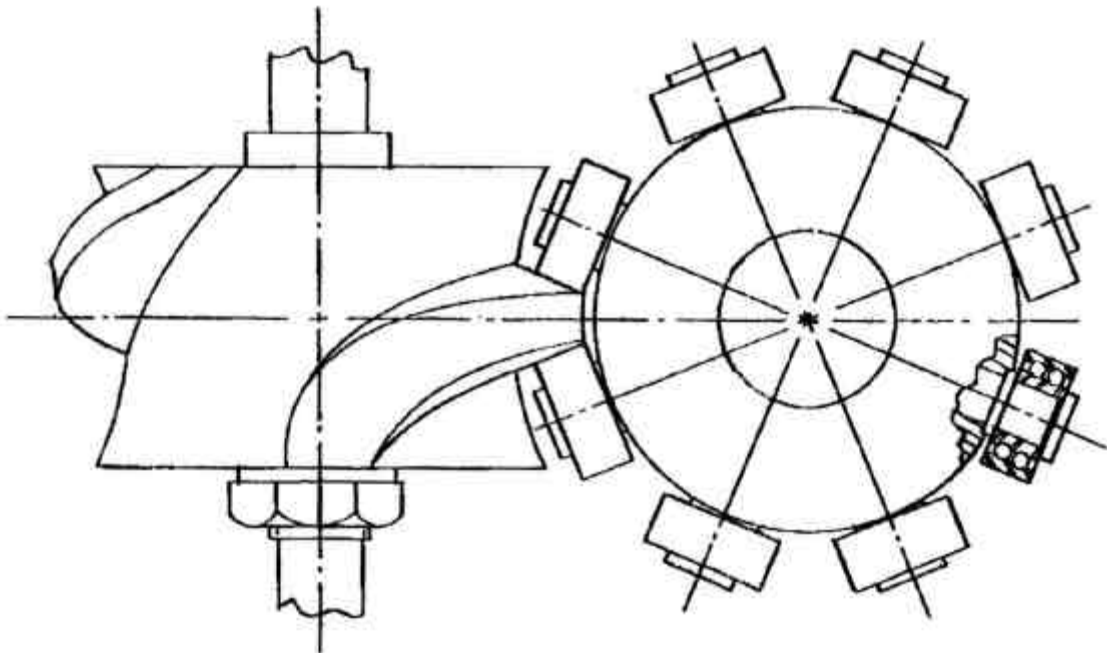

Figure 57

The Roller Gear drive is a relatively new device and is used primarily for indexing production machinery.

The ratchet mechanism shown in figure 58 also produces an intermittent rotation of the driven parts.

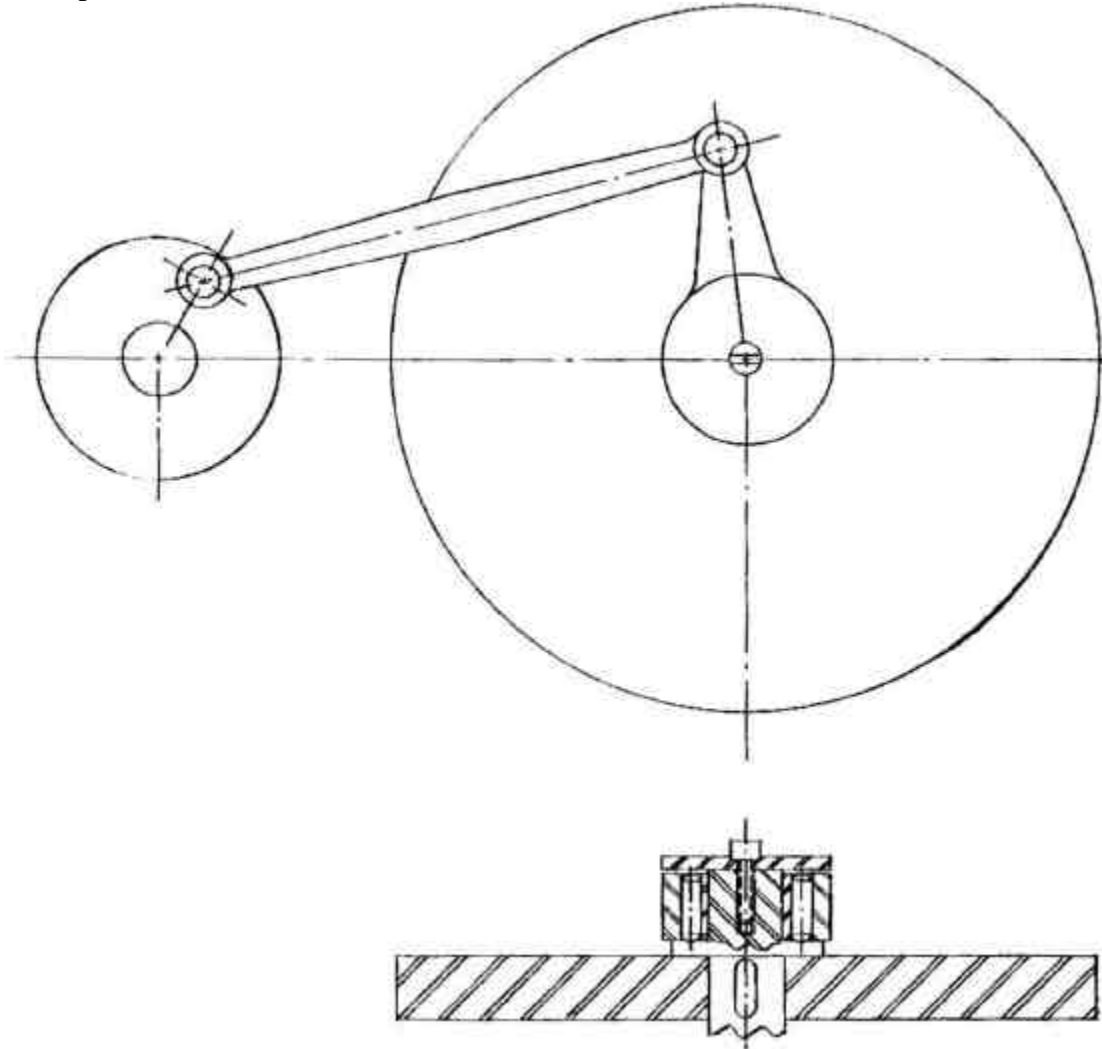

Figure 58

Pawl and tooth ratchets have been used in this type of mechanism, but for prolonged service at higher speeds and loads, a one direction clutch of the roller or sprag type should be used. The amount of rotation can be varied by adjusting the length of either the driving or driven cranks. In case such an adjustment is provided, means must be provided to lock the adjustment so that it will not change during operation.

The ratchet device is generally the least durable part of this mechanism, hence it should be generously proportioned with hardened parts where necessary to prevent wear.

Although the illustrations show some of the commonly used intermittent motion devices, many more such mechanisms can be designed. Mechanism and Kinematic texts will often provide ideas which can be successfully used. When considering such devices, however, the designer must constantly bear in mind the probable cost of manufacture and the durability which might be expected.

38. LINKAGES

Any train of machine parts which transmit motion is correctly called a linkage. However, the term is commonly used to designate that part of a mechanism made of pins, levers, and bars, and transmitting something other than rotary motion.

Linkages take many forms and shapes, lending themselves to countless combinations limited only by the designers ingenuity. They may be used as the main actuating parts of a machine or as a controlling device. Because of this great diversity, no common linkages are discussed here. However, the student designer has only to consult a good Kinematics or Mechanism text to get ideas on various linkages.

In any linkage, the pins and bearings which make up the joints are the most vulnerable parts. Careful joint design is required if serviceable operation is to be obtained. Special attention must be given to keep friction and the tendency to bind at a minimum by keeping the loads centralized on the pins. This is illustrated in figures 59(a and b).

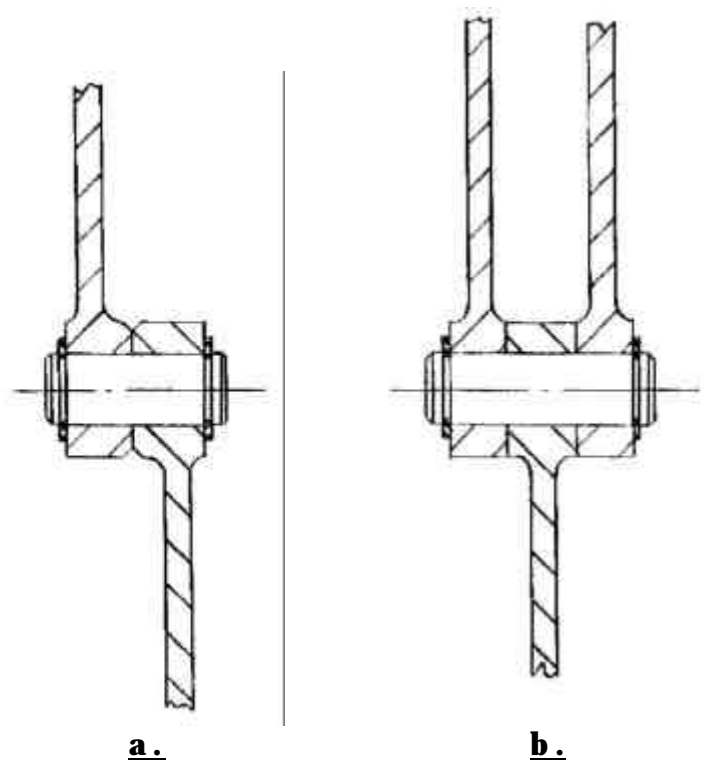

Figure 59

The construction of 59(a) tends to deflect the pin and link assembly, thus causing the joint to bind and prevent easy movement. This has been corrected in figure 59(b) by adding another piece to the upper link, thus centralizing the load on the pin.

If the linkage is large, the links are commonly cast or forged. In such cases the link can have enlarged ends to hold substantial bearings. This is often essential to obtain the necessary lateral stability. In smaller linkages the links are forged, cut from steel plate, fabricated by welding, cast, or stamped from sheet metal, depending upon the loads and allowable cost of production. In every case, the construction should be such as to provide free and easy motion of the joints and sufficient lateral rigidity to keep the parts in line and prevent binding due to unintended sideways motion.

Pins and bearings should be just as large as reasonably possible with means provided to lubricate the joints and keep out dirt. Either sliding or rolling bearings are successfully used.

If the linkage is to operate at high speed with heavy loads, it must be carefully designed to handle the combined inertia and load effects. These forces not only add to the stresses in the links and the loads on the bearings, but may cause instantaneous deflections that impair the operation of the linkage. In such a case, the links should be designed to have light weight with maximum rigidity.

CHAPTER VII

DESIGN OF CASTINGS AND WELDMENTS

A large number of machine parts are fabricated by casting or by welding. Although both have their relative advantages and disadvantages, choice between casting and welding is often decided by cost. Casting is generally more economical if the part is to be produced in quantity. Because of the cost of patterns required for casting, however, welding is often advantageous when only a relatively few pieces are to be produced.

39. CASTING DESIGN

Casting is an extremely versatile method of making metal parts. Iron, steel, aluminum, bronze, etc. can all be cast economically into shapes that could not be suitably produced by any other method. It is especially useful when large housings, bases, etc. are to be made. Ample strength and rigidity can be quite easily obtained, especially with steel castings.

Castings should be carefully designed to take full advantage of the economy inherent in the casting process without sacrificing the quality of the finished part. The designer should consider ease of casting and machining as well as the shape required to allow the part to function properly.

Casting design is often influenced by the methods, size of equipment, etc., at the foundry where the castings are to be made, as well as by the machines and methods available for the machining operations. It follows, then, that what might be an excellent design in one case might not be satisfactory in another. However, there are certain basic considerations which apply in all cases, and some of these are pointed out in the following paragraphs.

The most important rules for good casting design can be stated briefly:

- a. Use relatively thin sections enlarged where necessary to hold other parts, permit fastening, etc.
- b. Provide bosses or machining pads wherever flat surfaces are to be machined.
- c. Reinforce the edges of the piece by providing an enlarged section.
- d. Provide bosses around holes or openings in the part to reinforce the part and thus make up for the metal lost due to the hold.
- e. Strengthen and stiffen light sections with ribs.
- f. Blend thick and thin sections together gradually to eliminate cooling difficulties.
- g. Always provide generous fillets where two surfaces come together, being careful to eliminate all sharp corners.

h. Use simple curves which are easy for the patternmaker to produce.

Figure 60(a) shows a circular end bell of a housing, a typical piece made by the casting process. It illustrates most of the eight rules stated above.

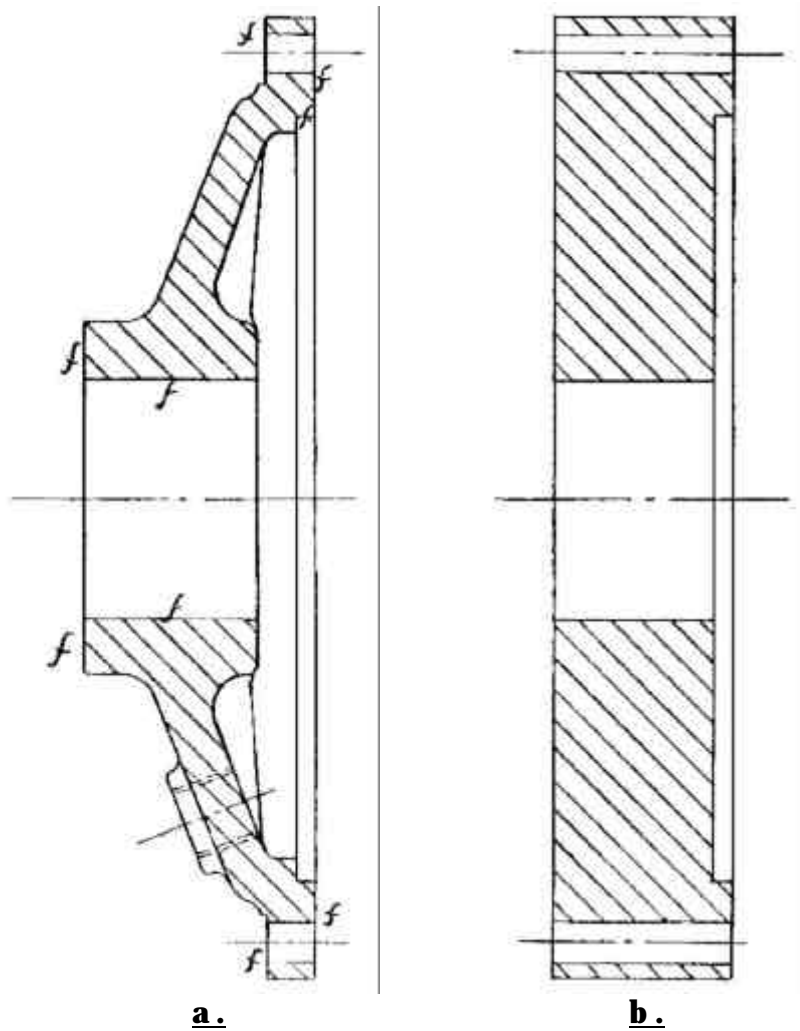

Figure 60

The thickness of the piece at the bearing bore is dictated by the width of the bearing. Notice, however, that this thickness was not maintained all the way to the outer edge of the piece, as this would result in excessive weight and waste of material. Notice instead, the thin walls blended into the central boss with generous fillets.

Machined surfaces are indicated by an "f" in figure 60(a). Notice how the machined surfaces stick out from the surrounding surfaces. In this way, only the necessary surfaces are machined and the machining can be done easily. The part shown in figure 60(b) would have to be machined all over to obtain the same result as that obtained by machining the surfaces shown in figure 60(a).

No complex curves are used in figure 60(a) and a boss has been provided around the drain plug hole. Stiffening ribs are used to reinforce the rather large but thin section which joins the heavier inner and outer parts of the casting

The hoisting drum shown in figure 61 illustrates another typical cast construction. Again notice the thin sections, the heavier sections to hold the shaft, the stiffening ribs, and the reinforcing rims around the edge of the flanges, while the center bosses extend beyond the flanges to permit easy machining of the end surfaces.

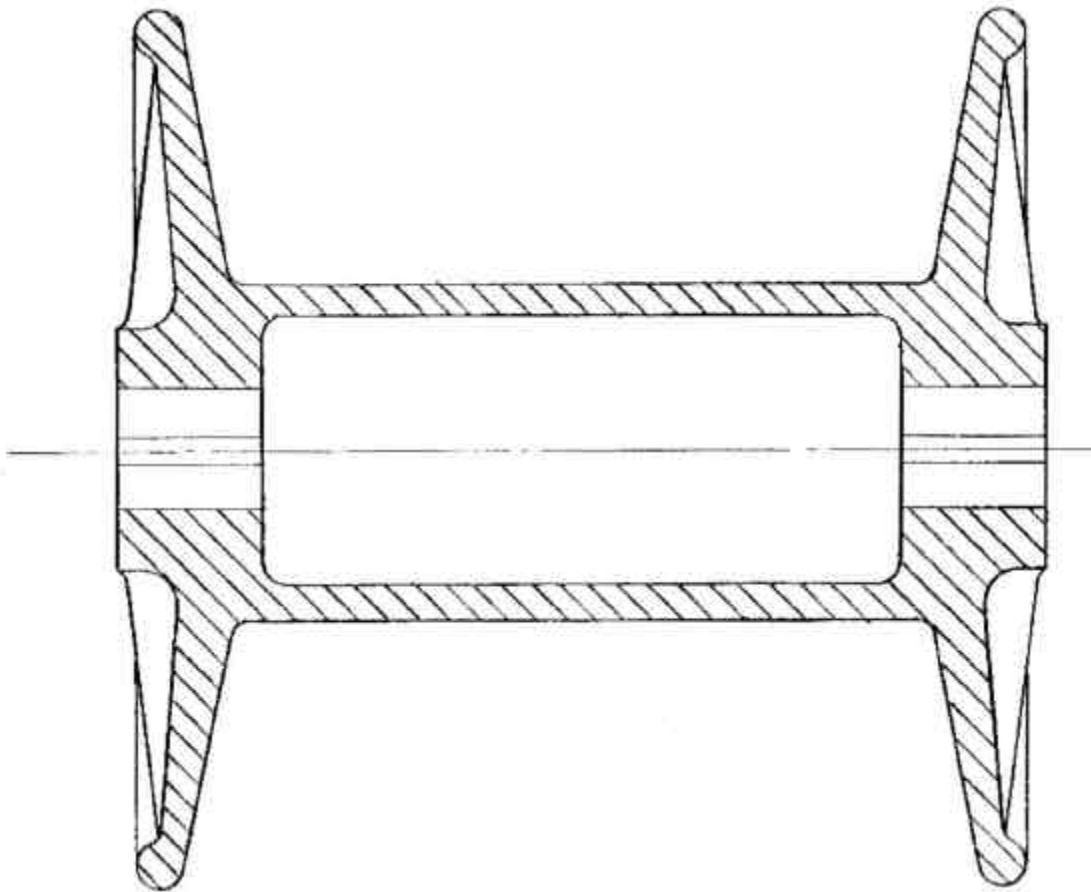

Figure 61

A cast machinery base is shown in figure 62, again illustrating many of the rules stated. The beginning designer should study carefully the illustrations shown, and should note these same features illustrated in drawings of machinery of all types where castings are used.

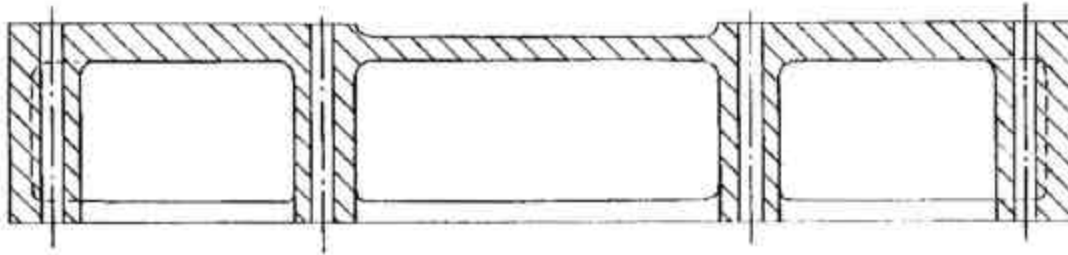

Figure 62

40. WELDING DESIGN

Many of the parts made by casting could also be fabricated by welding. Rolled plates and rolled structural members (beams, channels, angles, etc.) are commonly used to build up the necessary structure.

The general rules for good weldment design are very much the same as for good casting design:

- a. Use relatively thin sections, enlarged where necessary by welding in bosses, rims, etc.
- b. Provide bosses or machining pads wherever flat surfaces are to be machined.
- c. Strengthen and stiffen light sections with ribs.
- d. Use simple curves which can be easily obtained by bending plates.

In addition to the above rules, provision must be made to allow the welding arc or torch to reach the place to be welded.

Due largely to the uniformity of rolled plates and structural members, welded structures tend to vibrate more than cast structures. Care must be taken to stiffen large thin sections with ribs so as to damp out this vibration.

Most weldments are made of steel which is inherently much stiffer than cast iron. The advantage of this greater rigidity can be quickly lost in weldment design by the use of excessively thin non-reinforced sections, however.

Figure 63 shows a circular end bell of a housing as made by welding. It illustrates most of the rules stated above. In this case it is fabricated entirely from steel plate, flame cut and welded together. Notice the bosses, stiffening ribs, and edge flange, all welded together with the main plate.

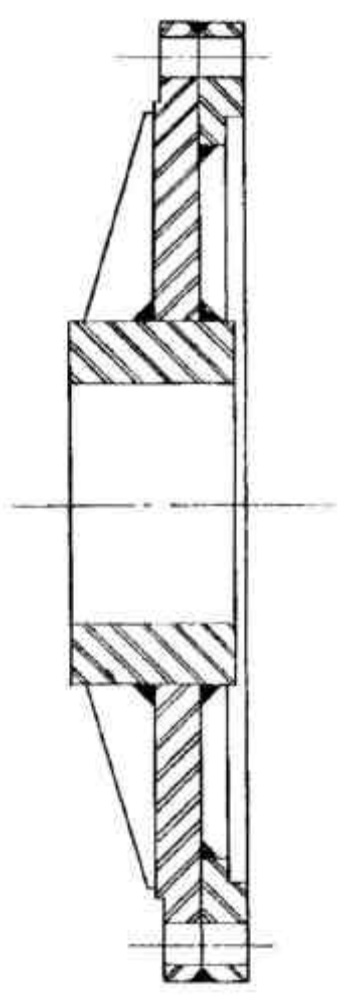

Figure 63

Figure 64(a) shows a cast lever, while figures 64(b and c) show comparable welded constructions. Here steel plate and tubing or bar stock have been combined. The finished machining must be done after the welding has been completed.

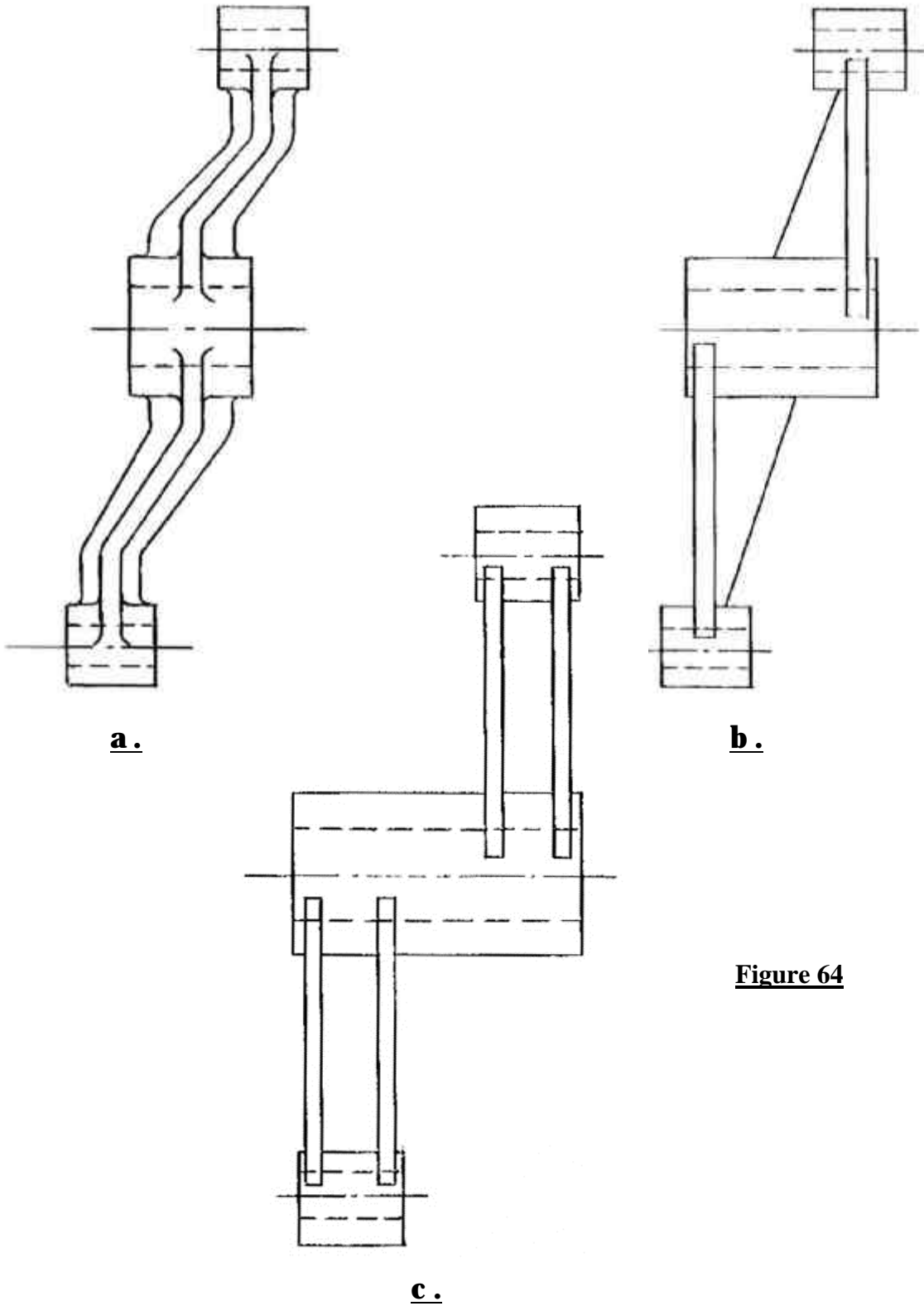

Figure 64

A welded machinery base built of rolled structural members and plates is shown in figure 65. Warping during the welding process can be a serious problem in this type of design unless proper holding facilities are available.

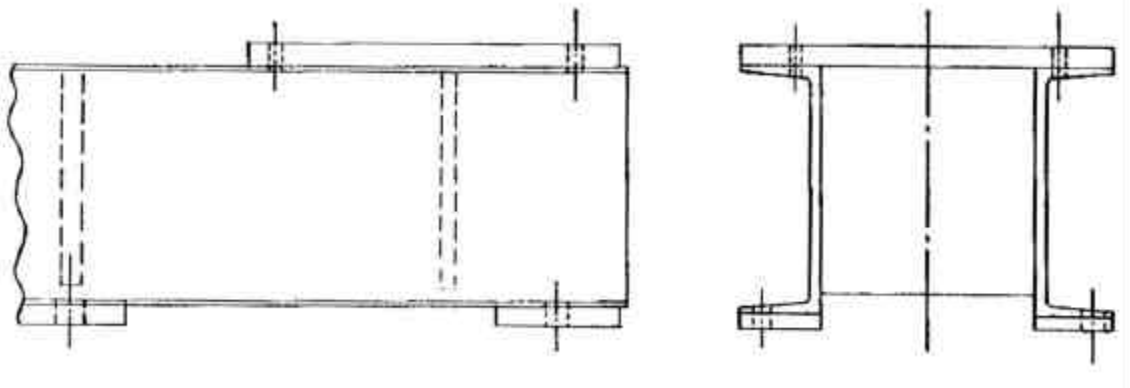

Figure 65

Light weight steel metal parts can be economically fabricated by various welding processes on a production basis. In such cases the parts to be welded are commonly formed by pressing or stamping operations, thus allowing more intricate shapes than those shown. Forging of the components prior to welding can also be used to advantage where more intricate shapes as well as high strength are required in large machine parts.

CHAPTER VIII

HOUSING DESIGN

A housing encloses and supports the machine parts. It is most commonly made of cast iron or cast steel although welding is also used as a means of fabrication.

Most of the material in Chapter VII, Design of Castings and Weldments, applied directly to the design of housings, hence should be carefully studied before attempting to design a housing.

41. ONE PIECE AND MULTIPLE PIECE CONSTRUCTION

One piece housings are almost always stronger and more rigid than housings built up of several pieces. In most machines, however, a one piece housing is impossible due to machining and assembly requirements. The multiple piece housing thus becomes a necessity in most cases, and one of the first problems confronting the housing designer has to do with the best method of splitting up the housing to allow machining assembly.

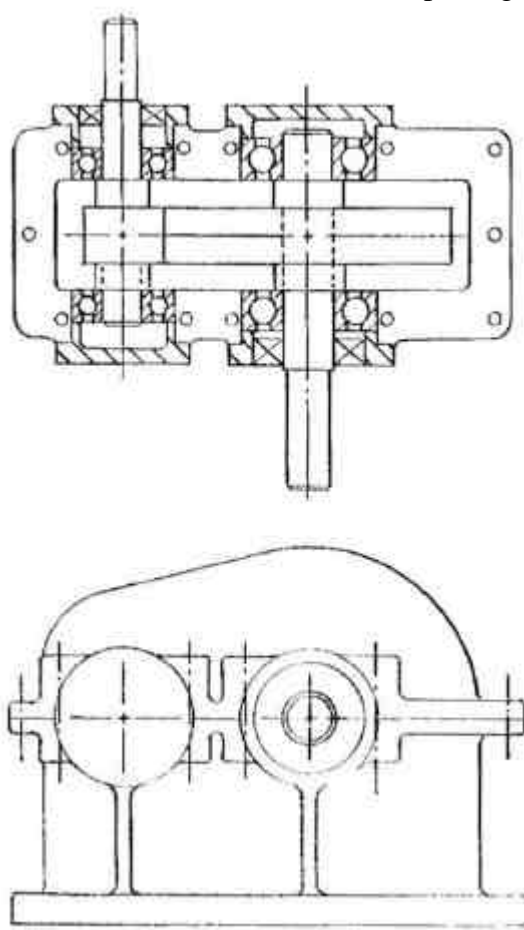

Figure 66(a)

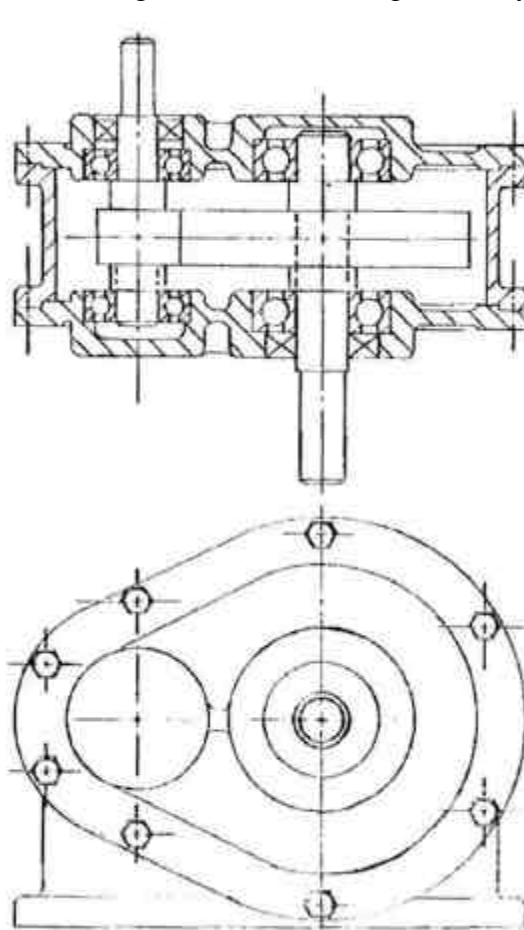

Figure 66(b)

Consider the single step geared speed reduction unit shown in figures 66(a and b).

Figure 66(a) shows a two piece cast iron housing with the joining surfaces in the same horizontal plane as the shafts, while figure 66(b) shows a three piece housing with the joining surfaces perpendicular to the plane of the shafts. In each case the sections of the housing are held together by steel bolts, and for the machine shown in figure 66, either construction would be satisfactory.

It must be kept in mind, however, that in a construction such as 66(a) where the bearing bore is common to two pieces, these two pieces must be bolted together then bored together for the bearings. It is not possible to bore one half the hole in each piece, then put the two pieces together and have them form a perfect enough circle to hold a bearing.

With this in mind, it is readily seen that the housing construction shown in figure 67(a) is virtually impossible to machine since the inner bearing bore is inaccessible.

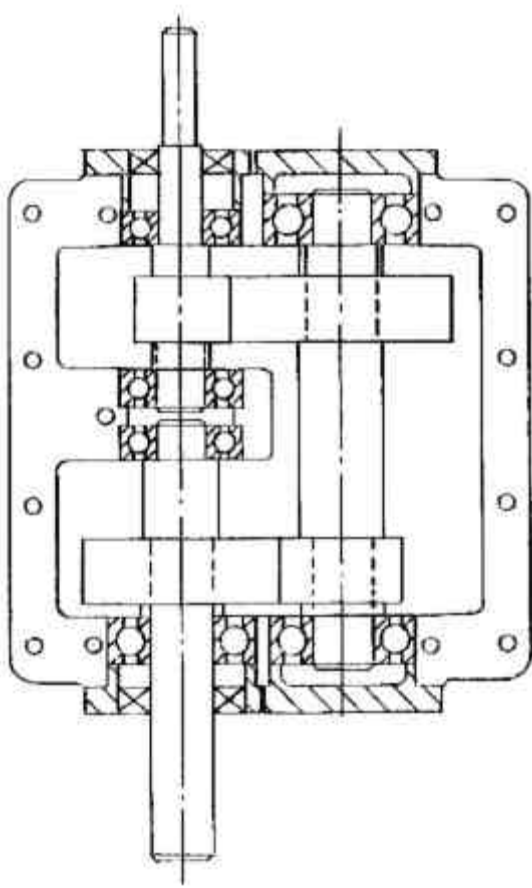

Figure 67(a)

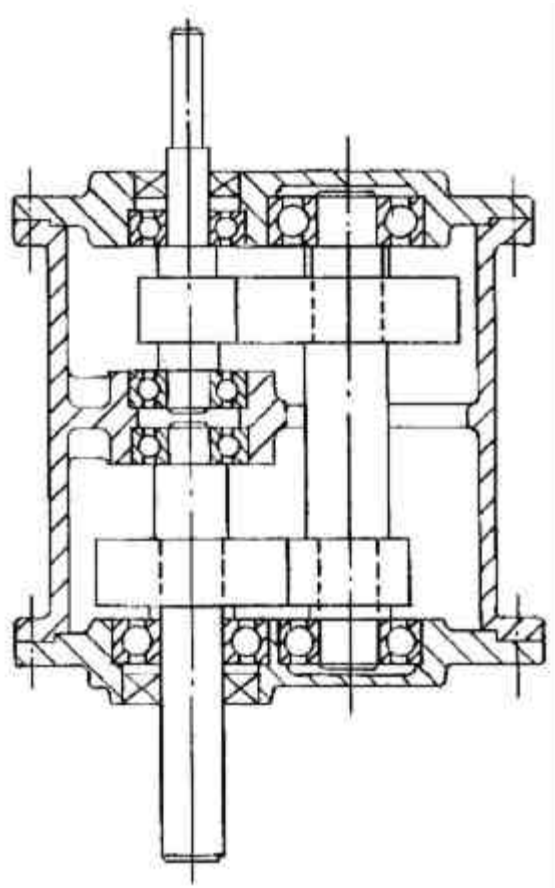

Figure 67(b)

So long as the bearings are located in the outer wall of the housing, and so can be machined with the two parts together, the type of housing construction shown in figure 66(a) is satisfactory. When this is not the case, the construction shown in figures 66(b) and 67(b) must be used. This is the construction most commonly found in housings, although the construction shown in figure 66(a) is also widely used where conditions are satisfactory.

42. MEANS OF FASTENING

As shown in figures 66 and 67, the multiple piece housings are fastened together with steel bolts. If the joining surfaces are in the same plane as the shafts, as shown in figure 66(a), flanges and through bolts are commonly used. The flanges should be substantial and the bolts placed as close to the wall as possible. Thus the bolts pull the housing pieces rigidly together rather than just bend the flanges. Care must be taken to get the bolts as close to the bearing bores as possible so that bearing loads will not deflect the housing. Proper design is shown in figure 66(a).

Figure 68 shows another construction which is commonly used on small housings. In this case the bolts pass through one piece of the housing, rather than through a flange, and provide a very rigid construction.

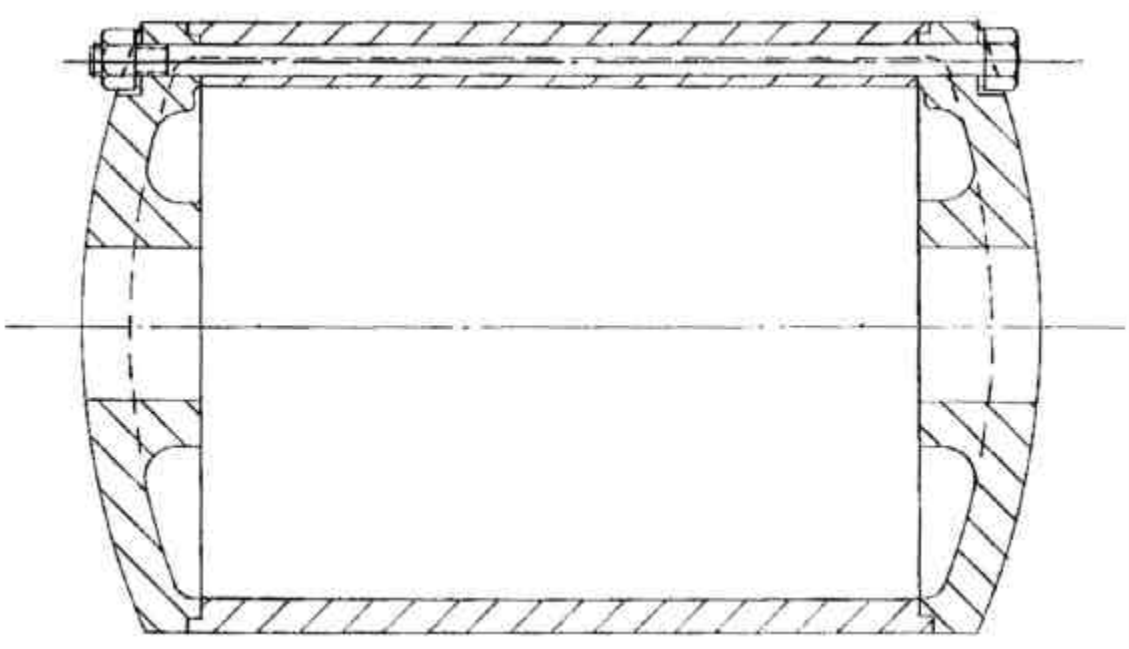

Figure 68

If the joining surfaces of the multiple piece housing are perpendicular to the shafts as shown in figures 67(b) and 68(b), flanges and through bolts can also be used as shown. Again the flanges should be substantial, and the bolts located as near to the housing wall as reasonably possible.

Modifications of this same construction are shown in figures 69(a and b). In both cases capscrews threaded into the housing are used instead of through bolts. These constructions are probably not as strong as when through bolts are used, but they can be designed to be perfectly satisfactory. Furthermore, a cleaner and smoother appearance results which is desirable.

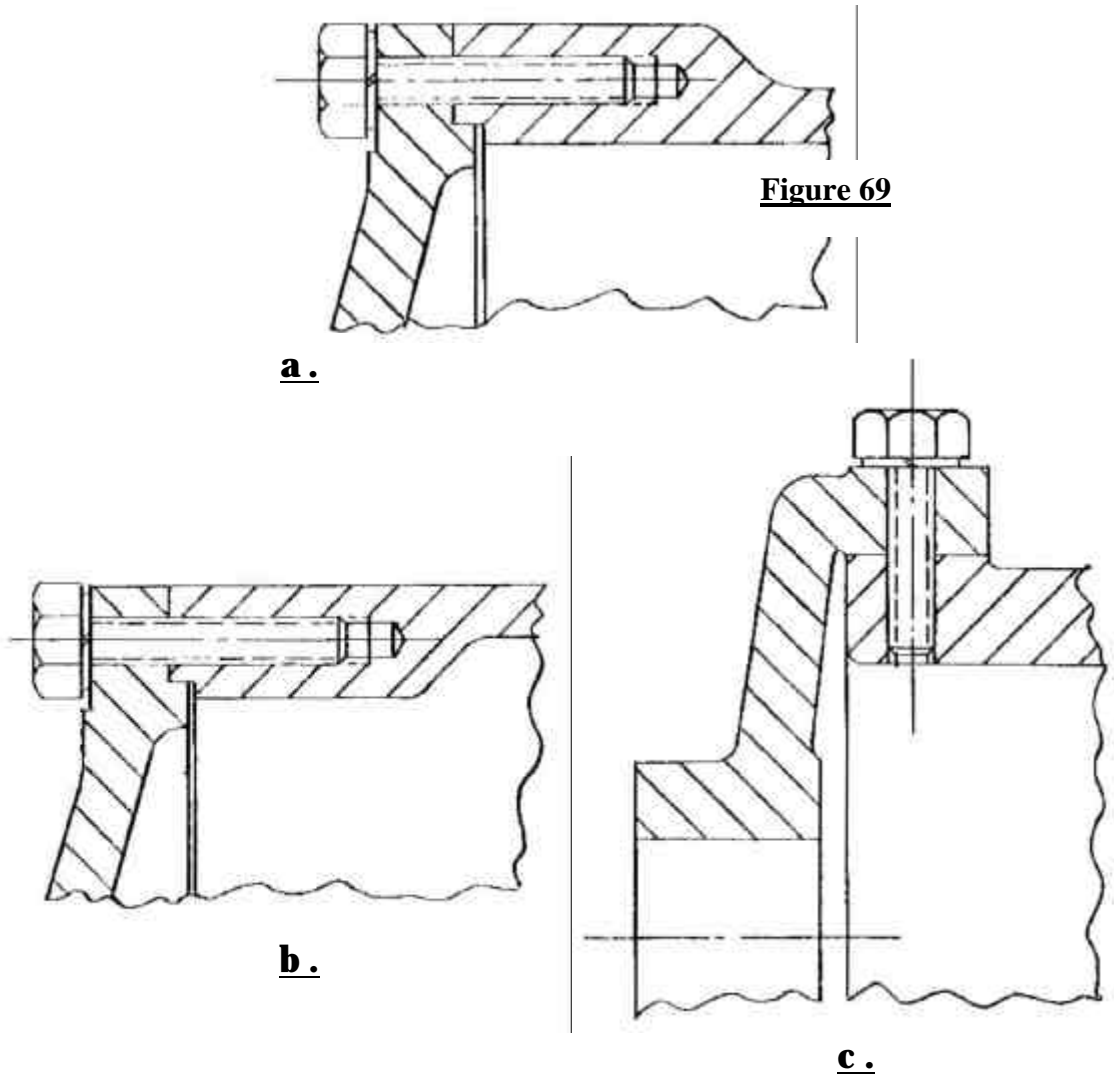

Figure 69(c) shows a construction that is entirely unsatisfactory and must be avoided. Tightening the bolts will only distort or break the housing as the bolts try to pull the pieces together.

In any construction of this type, good sized bolts should be used and should be spaced close enough to one another to hold the pieces securely.

43. ALIGNMENT OF PIECES AND SHAPES OF HOUSING

Means must be provided to get the various pieces of the housings to line up properly when the machine is assembled. This is essential for the construction shown in figures 66(b) and 67(b) since the bearings supporting any of the shafts are in separate pieces of the housing. This lining up cannot be done by the bolts which hold the housing together since these bolts cannot be very accurately located themselves. Because of this, and to aid assembly, the holes through which the bolts pass are considerably larger than the bolts completely incapable of accurately aligning the housing parts.

The most common and best method of obtaining proper alignment of the housing parts is by piloting one part inside the other as shown in figure 70. The pilot surfaces are accurately machined so that when the parts are assembled, accurate alignment automatically results.

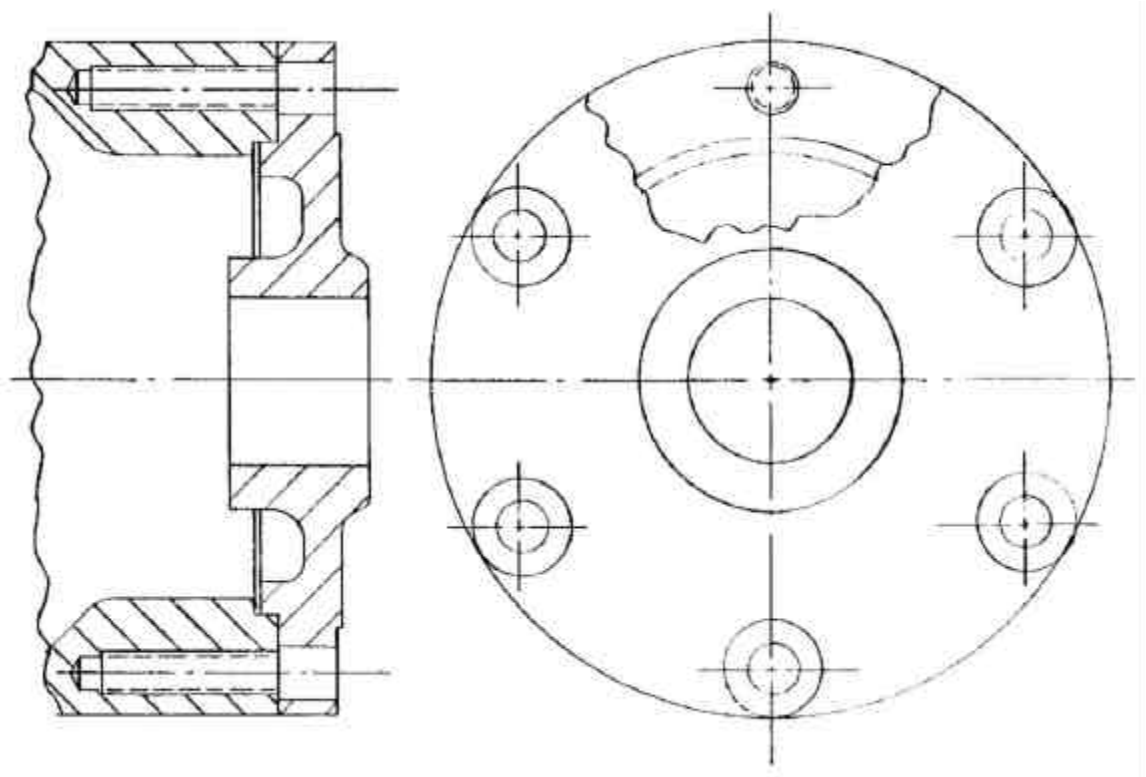

Figure 70

The piloted surfaces can be accurately and economically machined by a turning operation only. Hence it follows that the housing must have a cylindrical shape at the joining surfaces, as illustrated in figure 70, to allow this essential piloted construction.

It does not follow that all housings of this type must be perfectly round however. This is illustrated in figure 71, where the housing consists of two cylindrical parts joined by straight walls. In such a case, the two pieces of the housing are piloted only at the cylindrical parts, rather than all around the joining surface.

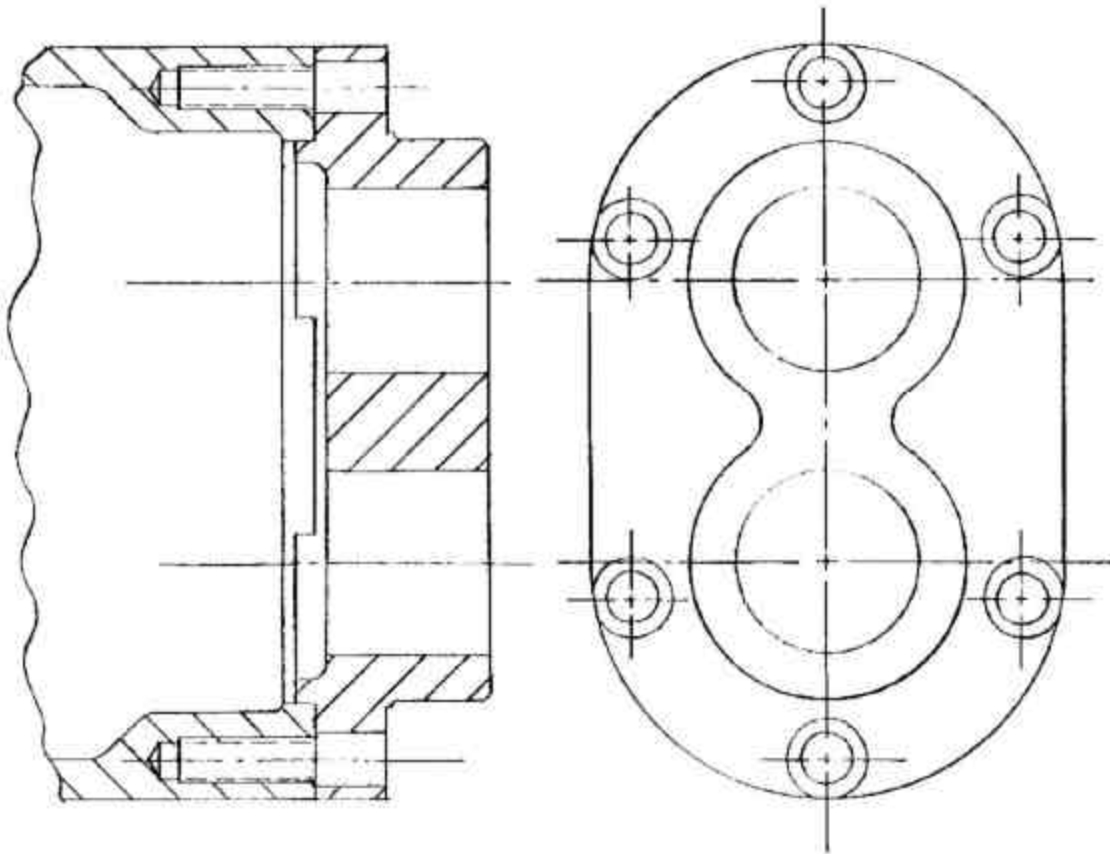

Figure 71

When designing parts as shown in figure 71, care must be taken to have the parts of such a shape that the entire joining surface can be machined flat, at the same time retaining the piloting surfaces. Again it must be kept in mind that this machining must be done by a turning operation and the part must be shaped accordingly.

With few exceptions, housings of this type must be formed by one or more cylindrical shapes as illustrated. Care must be taken to keep the shape relatively simple at the joining surfaces, however, to allow the parts to be machined and piloted.

44. HOUSING OPENINGS AND CAPS

Openings of one sort or another must often be provided in the housing to allow inspection, facilitate assembly, or to permit adjustments to be made. A common opening occurs at bearing bores, and these are commonly closed by caps as shown by several illustrations in Chapter II. These caps are really parts of the housing and the general ideas developed previously in this chapter must be applied. The caps are commonly piloted in the bearing bore, although the caps can be piloted on the outer race of a ball or roller bearing by allowing the bearing to extend slightly from the housing.

Openings in the cylindrical surfaces of the housing must be made so as to provide a flat, machined surface for mounting the mating parts. Correct and incorrect constructions, using a cover as the mating part, are shown in figure 72.

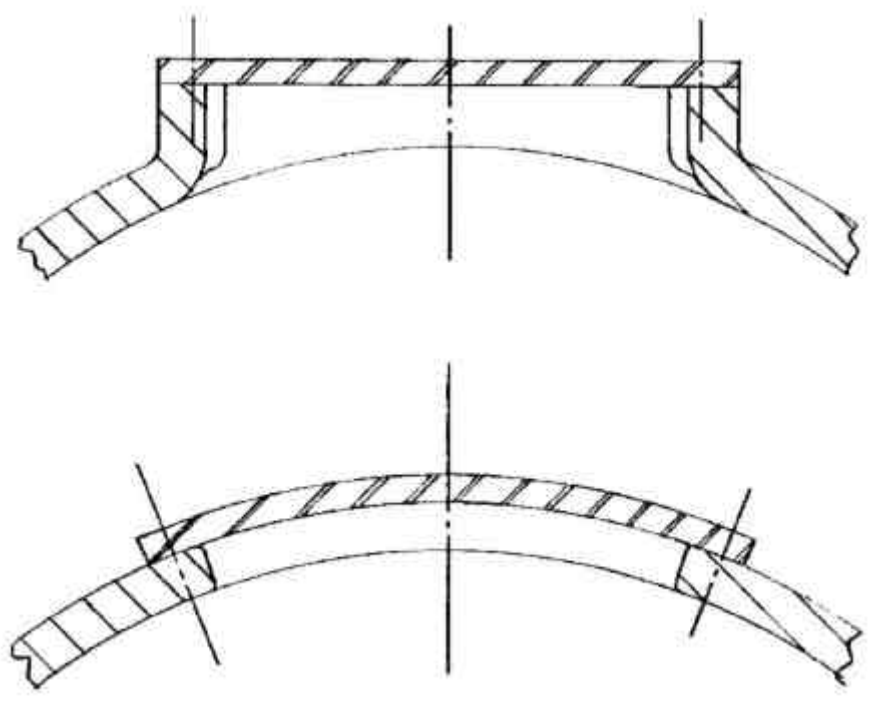

Figure 72

45. SUPPORTING THE HOUSING

The housing, which commonly supports the machine parts, must itself be supported on a floor or foundation surface. This is generally accomplished by forming a base as part of the housing. A construction of this type is shown in figure 73. Notice that in figure 73 the base is on only one piece of the housing and the housing should be designed with this in mind. If more than one piece of the housing were extended downward to rest on the floor or foundation, difficulty would be encountered in trying to get the bottom surfaces of the pieces to line up together. Hence the base should be made of one piece wherever possible.

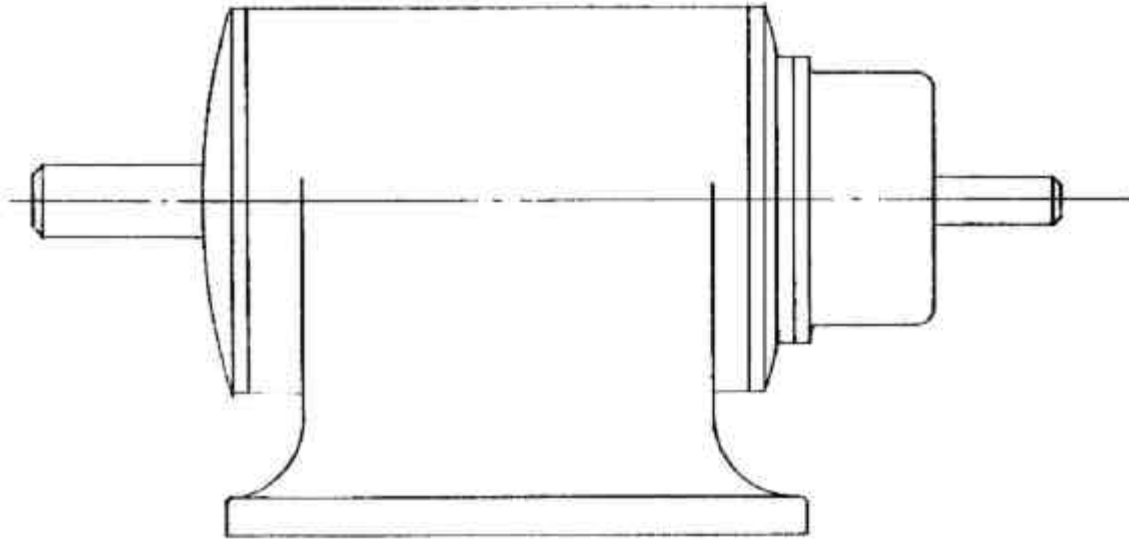

Figure 73

A one piece base is sometimes out of the question, however, in which case a two piece base as shown in figure 74 can be used satisfactorily. Notice that here the end pieces form the base, holding the center section between them.

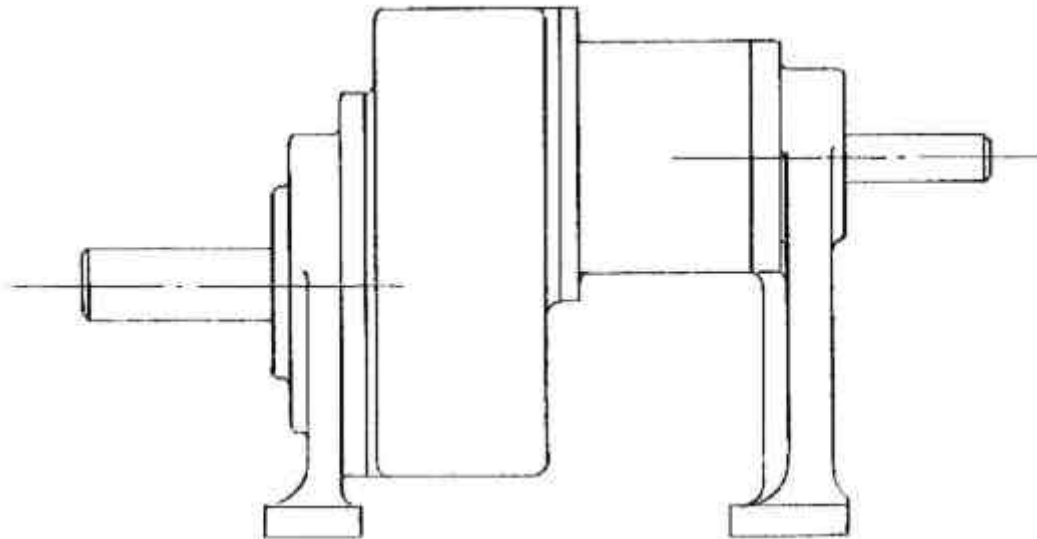

Figure 74

In any case the base should be made so as to allow the machine to stand by itself. Bolt holes should be provided so that the machine can be fastened to the floor or foundation. When the machine is bolted down, the bolts can exert very large forces on the base. If the floor is not perfectly flat, distortion or breaking of the base might result. Because of this the base should be substantially proportioned and should not contact the floor over a large area.