

ZEROPLAY[®]

360 SLED KIT PROJECT PLANS



INCLUDED ITEMS

Parts for ZEROPLAY 360 Sled Kit		Qty	Part #
[A]	ZEROPLAY™ Top Guide Bar	1	ZP-P1
[B]	ZEROPLAY™ Bottom Guide Bar	1	ZP-P2
[C]	#8-32 x 3/16" Button Head Screws	3	ZP-H1
[D]	3/32 Hex Wrench	1	ZP-H2
[E]	#8-32 x 1/2" Pan Head Machine Screws	3	ZP-H3
[F]	#10 Flat Washers	3	ZP-H4
[G]	10-32 1-1/2" Track Screws	4	DV-HL5
[H]	10-32 Wing Knobs	4	GR-H52

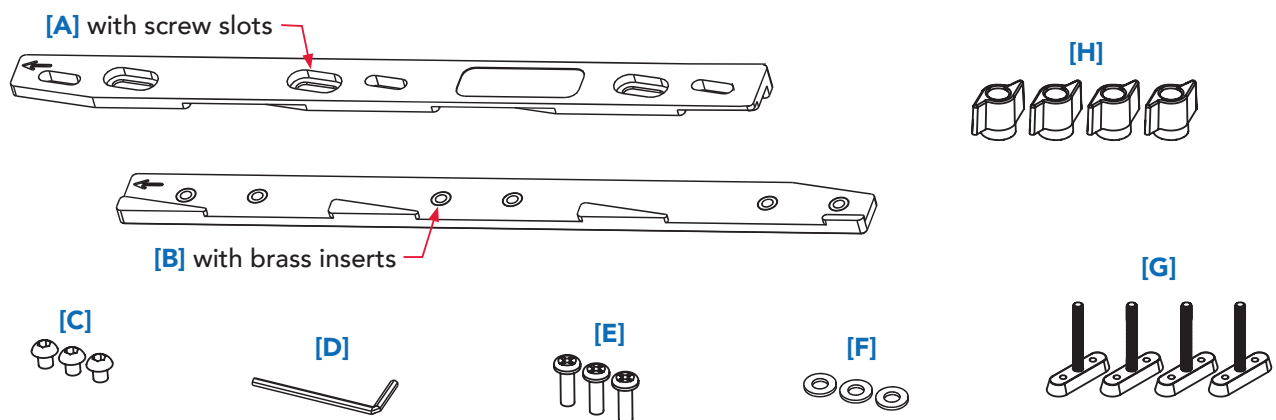

PROJECT OVERVIEW

The ZEROPLAY 360 Sled combines the ease of ZEROPLAY Miter Bars with the versatility of the Dovetail Track System. This setup allows you to position the 360 Sled fence at any angle while keeping the sled parallel to the blade.

The dovetail tracks can also be used to add stops and secure material using MATCHFIT Dovetail Clamps—allowing you to make cuts safely and repeatably while your hands away from the blade.

Follow along with the full instructional video: microjig.com/360sledvideo

TOOLS & MATERIALS

- Table saw
- Router table
- 3/4" thick, 22"x 20" wood
Void-free plywood, standard MDF,
or seasoned solid wood (Baltic birch
recommended)
- MATCHFIT Dovetail Router Bit
OR standard 1/2"–14° dovetail bit
- Adjustable square
- 1/2" forstner bit
- 1/4" standard drill bit
- 5/16" standard drill bit
- Phillips-head screwdriver
- (2) five-cent coins
- 3/4" thick small scrap wood
- Pencil or pen

NOTE: *Make sure your table saw's miter slot and rip fence are parallel to the blade before following these instructions.*

STEP 1

CREATE THE BASE OF THE 360 SLED

1. Cut your selected piece of wood to 22" x 20" using a table saw as needed.
2. Next, cut the piece down to 16" x 20" in a single cut. The off-cut piece (6") will be used to build the fence in **STEP 6**.

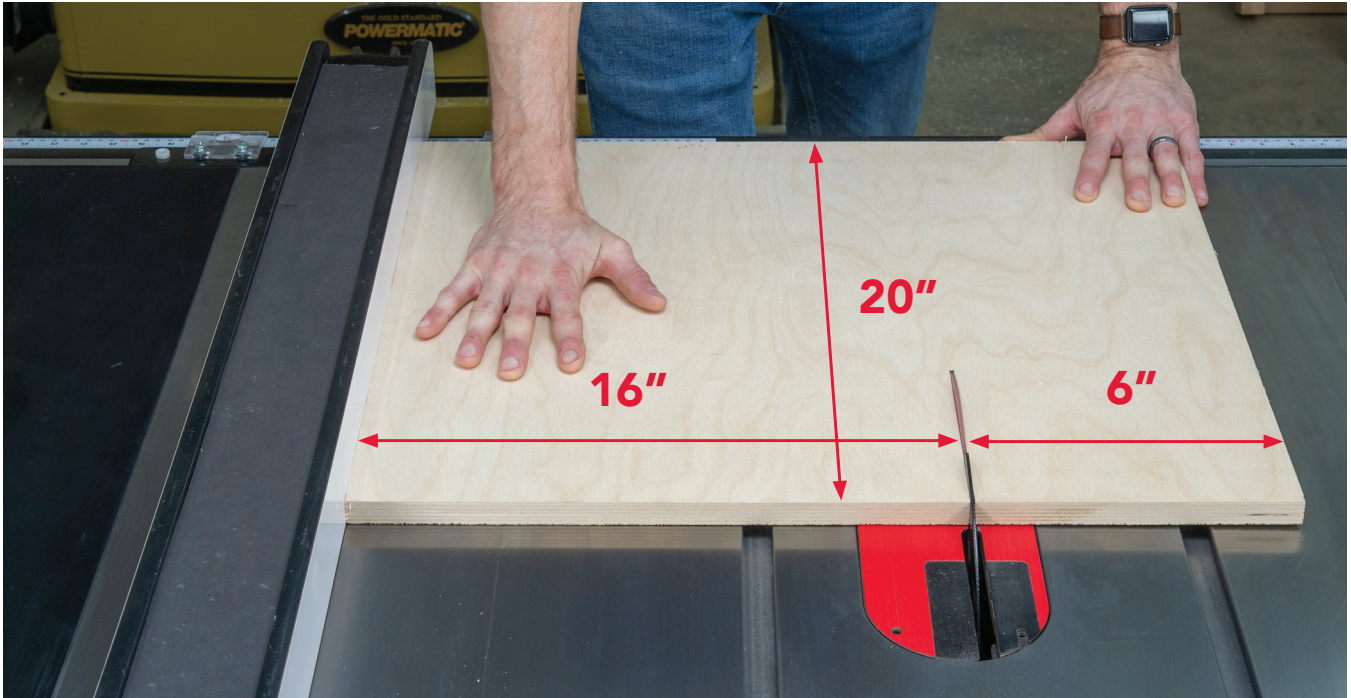

NOTE: Make sure all dimensions are accurate and corners are 90°.

STEP 2

CUT RELIEF GROOVES

Dovetail tracks are 4" apart on center. All measurements are from the center of the bit.

1. On your router table, set the 1/4" straight bit to a cutting depth of 11/32".
2. Set the router table fence to 4" and cut the four outside grooves by running each side along the fence. Rotate the workpiece 90° after each cut. (Fig 2.2)
3. After all four cuts are made, set fence to 8", and repeat previous step. Only a single cut is needed along the 20" side. (Fig. 2.3)

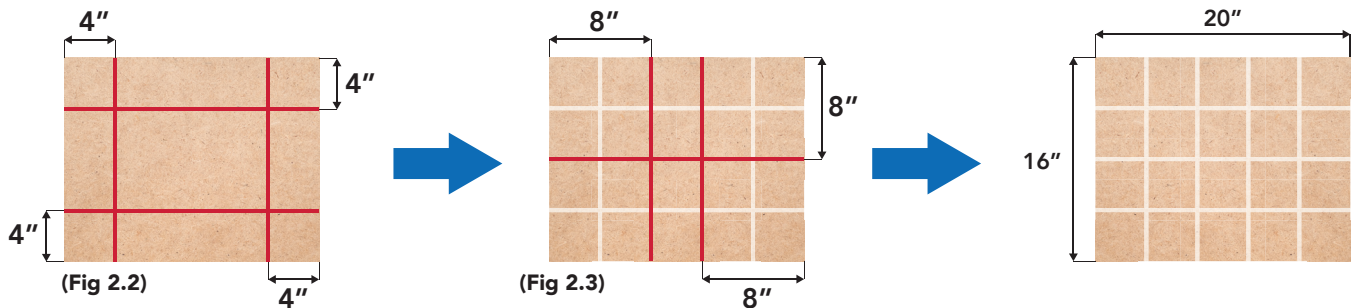
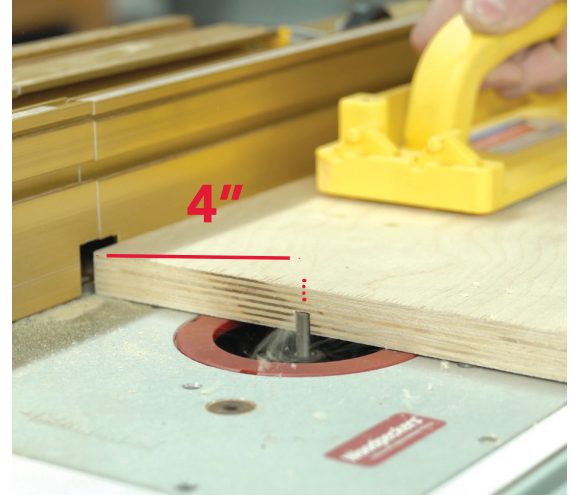

NOTE: An auxiliary fence is required if your router table fence can't be positioned 4" to 8" away. View instructions at: microjig.com/routertablefence

STEP 3

ROUTE DOVETAIL TRACKS

1. Using a 1/2"–14° dovetail router bit, set to a cutting depth of 3/8".
2. Test route a piece of scrap wood, and use the Dovetail Hardware to ensure that the dovetail bit profile and cutting depth are correct.
3. Confirm that the Dovetail Hardware remains inside the Dovetail Tracks and below the material surface when pulled up. **(Fig. 3.3)**
4. Proceed to route Dovetail Tracks in all relief grooves.

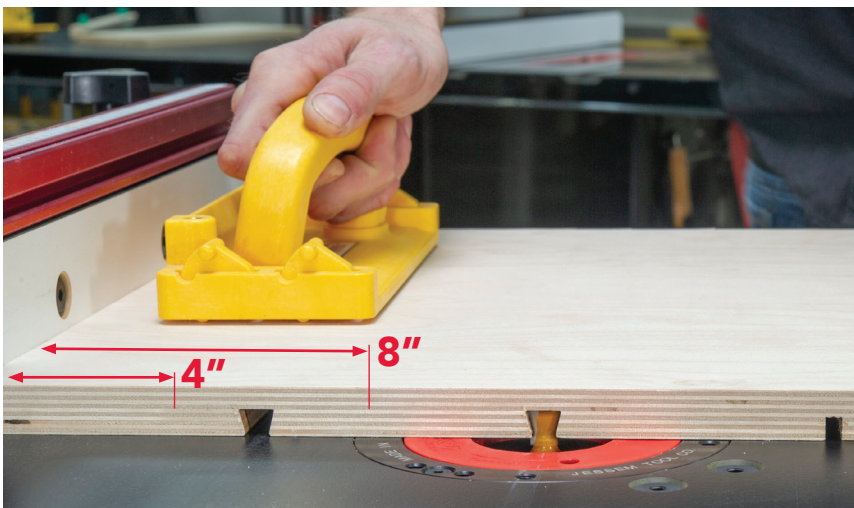

Pull up to test
Dovetail Track

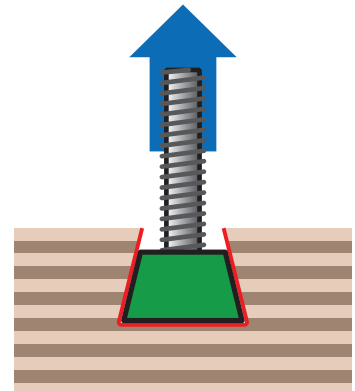

(Fig 3.3)

STEP 4

INSTALL MITER BAR

1. Stack the Top Bar **[A]** (with screw slots) onto the Bottom Bar **[B]** (with brass inserts), so that the arrows are pointing in the same direction and are visible from the top.
2. Insert the (3) button head screws **[C]** through the counterbored slots of the Top Bar **[A]** and loosely tighten using the included hex key **[D]**.
3. Insert two nickels in the bottom of your table saw miter slot, and then place the assembled Miter Bar on top of the nickels at its narrowest setting.
4. Expand the Miter Bar by holding the Bottom Bar in position with one finger, and gently sliding the Top Bar in the direction of the **arrows**. The Miter Bar should barely touch the sides of the miter slot. Over expanding the Miter Bar will make it too tight and prevent the bar from sliding freely.
5. Tighten the button screws **[C]**, and slide the Miter Bar back and forth through the slot to ensure it moves smoothly—with no side-to-side play. Remove the nickels from the miter slot.

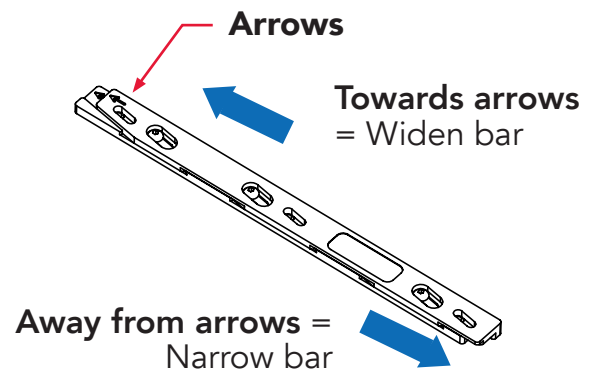

STEP 5

INSTALL MITER BAR TO SLED

1. Use an adjustable square to measure the distances **D1** and **D2** from both miter slot edges (closest to the blade) to the side of a carbide tip. Use the smaller of the two measurements as **X**.
2. Add $1/4''$ to **X**, and use the resulting measurement to draw lines down both 20'' and 16'' edges of the sled base. These lines are the center **drilling lines** for the Miter Bar, and allow the sled to be oriented horizontally or vertically. A gap between the blade and sled is normal in either orientation.

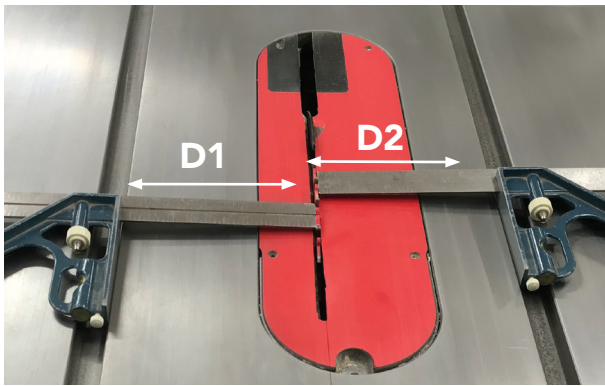

***NOTE:** Adjust the **drilling lines** distances if they are too close to a Dovetail Track.

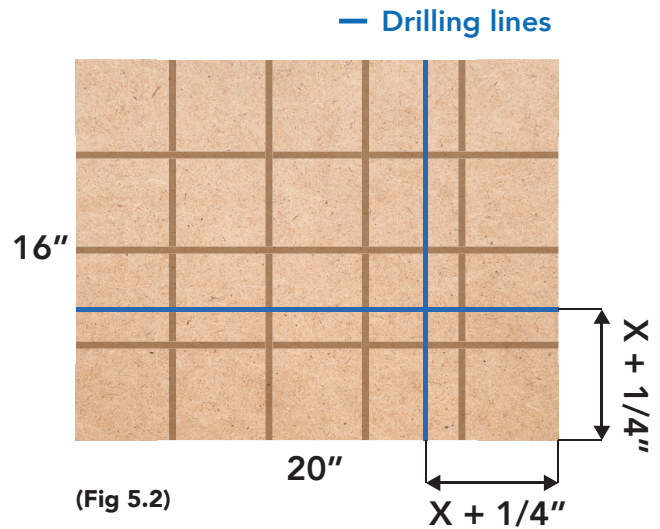

3. Find the **intersection** of the **drilling lines** and mark 4'' in each direction along the lines. These marks are the locations that will be drilled. (5 holes)
4. Using a $1/2''$ diameter forstner bit, counterbore $9/16''$ deep mounting holes, and then drill a $1/4''$ diameter thru-hole in the center of each mounting hole.

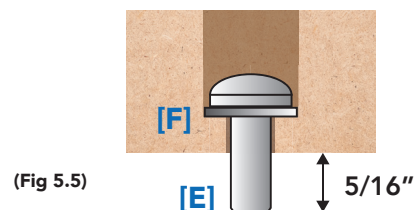
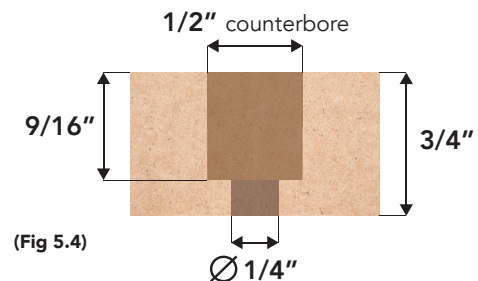
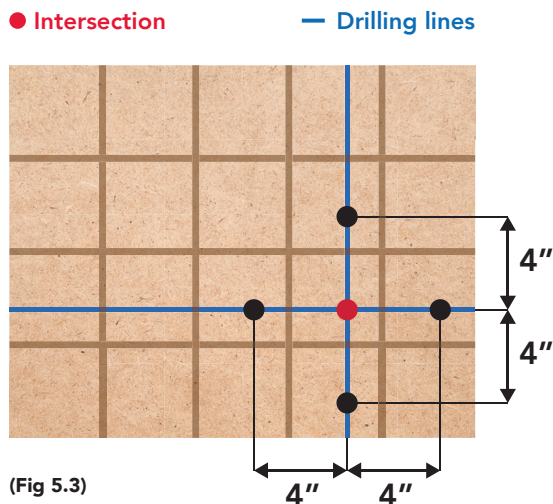

STEP 5 (Continued)

5. Insert a flat washer [F] and pan head screw [E] in each hole. Check that the screws extend 5/16" under the plywood to attach the Miter Bar properly.
6. Place the sled base on your table saw in the desired orientation, and line up the sled's mounting holes with the available brass inserts in the Miter Bar. Insert (3) pan head screws [E] but do not tighten them completely.
7. Use a carpenter's square to square up the sled base with the edge of the table saw top, and then tighten the pan head screws to secure the Miter Bar to the sled base (clear board used for clarity in the image below).
8. If you would like to change the orientation of the sled, remove the outer two pan head screws one at a time. Take care not to loose the screws and washers. Then, slightly loosen the center screw. Rotate the Miter Bar 90°, insert top and bottom screws, and repeat the previous step (5.7).

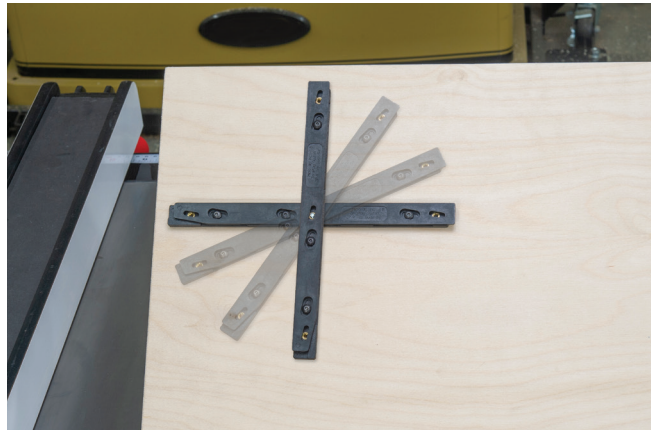
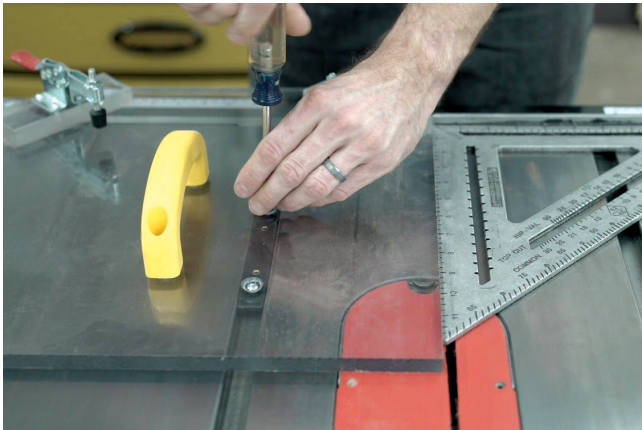

STEP 6

BUILD 360 FENCE

1. From the off-cut piece left over from **STEP 1**, cut a 2-1/2" strip (**Strip A**), and a 1-1/4" strip (**Strip B**) using your table saw (Fig 6.1).
2. On (**Strip B**), mark lines at 1-1/2" and 9" in from each end, and a line down the length of the strip 1/2" in from an edge. Drill 5/16" diameter thru holes where these lines intersect. These holes will be the beginning and end points of the dovetail hardware slots.

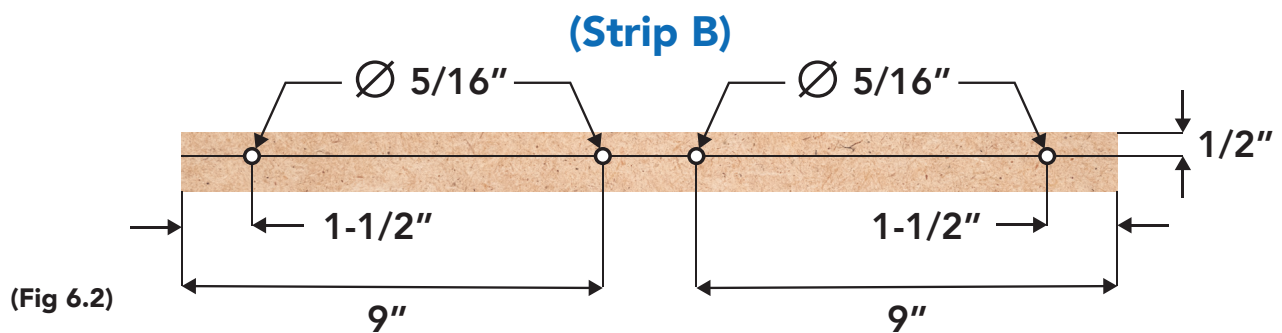
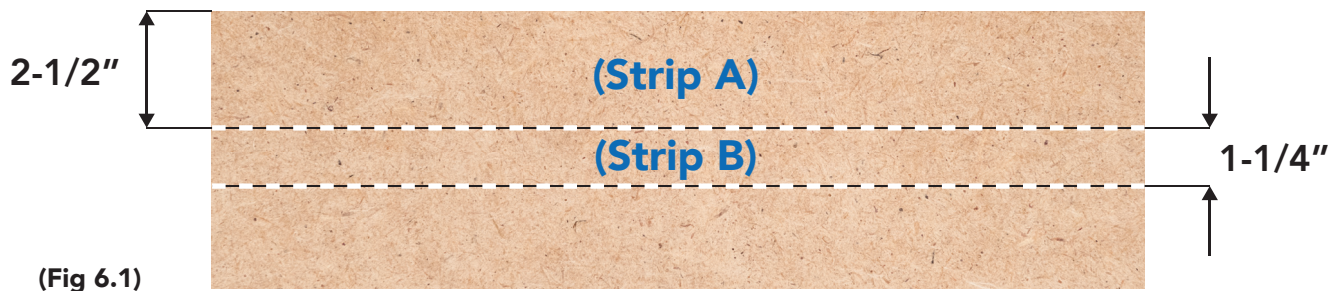

STEP 6 (Continued)

3. On your router table, set the 1/4" straight bit to a cutting depth of 1/4", and set the fence to 1/2".
4. Route between the 5/16" pre-drilled endpoints, and raise the cutting depth to 11/32" to make a second pass.
5. Flip the workpiece end-over-end, and repeat until both 7.5" slots are routed all the way through (Strip B).

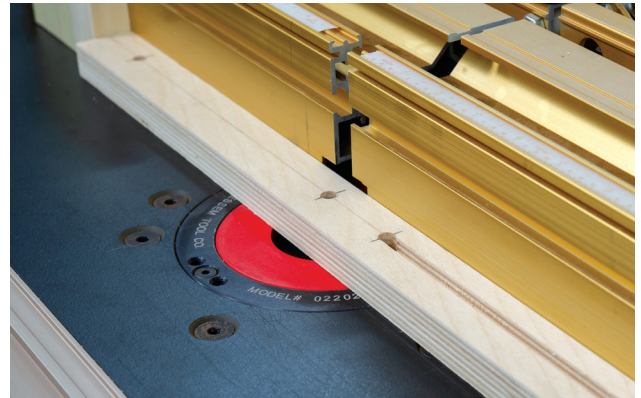
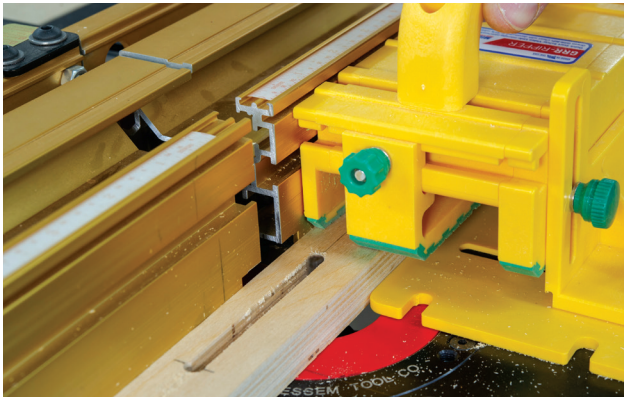
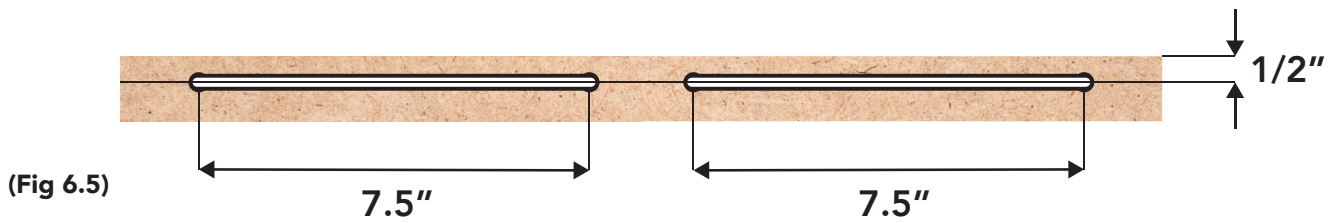

6. Glue and clamp the edge of the **(Strip B)** (closest to the slots) to the top face of the **(Strip A)** to form a 90° L-shape.

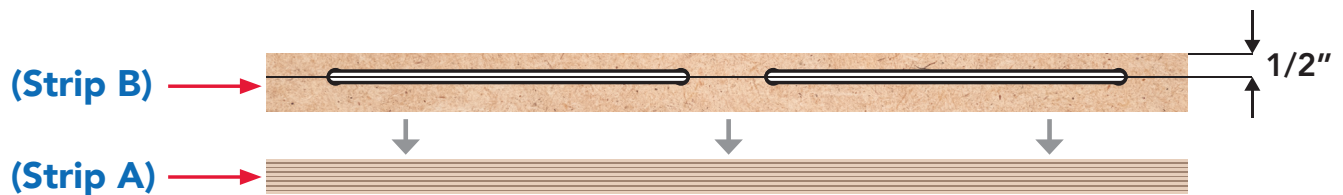

STEP 6 (Continued)

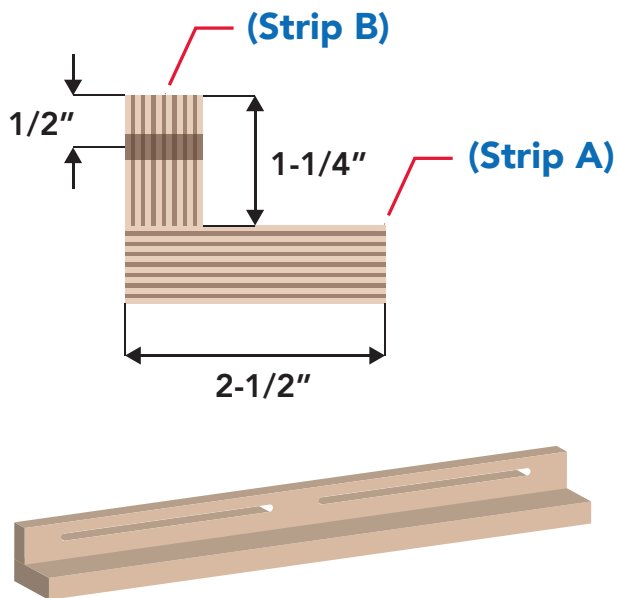

7. On your router table, set the fence to 1-1/4". Route a relief groove with the 1/4" straight bit set to a cutting depth of 11/32".
8. Set the dovetail bit to a cutting depth of 3/8", and route a 3/8" deep dovetail track down the center of **(Strip A)**.
9. Sand and chamfer finished 360 fence to soften edges, if desired.
10. Attach the fence to the 360 Sled by putting the Dovetail Hardware through the slots, and enjoy the most versatile sled in your shop!

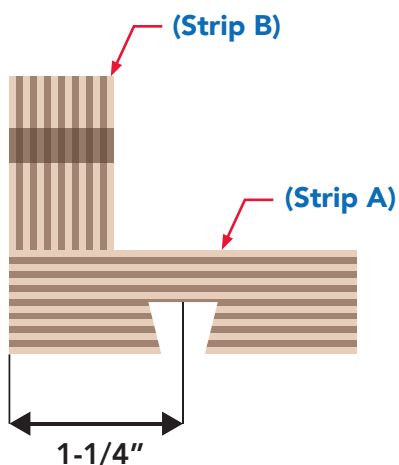

Work Safer. Work Smarter.

We hope that you enjoy these project plans and learn a few new tricks to use in your shop. Share photos of your completed project with us on Facebook, Twitter, and Instagram with the hashtag **#worksmarter**



BUILD THE ULTIMATE TABLE SAW SLED!

Scan this QR code or visit the URL below for access to our library of free jig plans—including the Ultimate Table Saw Sled and much more: microjig.com/zeroplayplans



Woodworking is an inherently dangerous activity. Be sure to follow all safety guidelines that come with your power tools.



Instagram: @microjig



Facebook.com/microjig



Twitter.com/microjig

