



**Escola Politècnica Superior  
de Castelldefels**

UNIVERSITAT POLITÈCNICA DE CATALUNYA

# **MASTER THESIS**

**TITLE: Linearization techniques of preamplified optical links**

**MASTER DEGREE: Master in Science in Telecommunication Engineering  
& Management**

**AUTHOR: Pere Sardà Carbasse**

**DIRECTOR: Maria Concepción Santos Blanco**

**DATE: January 21th 2010**



**Títol:** Tècniques de linealització d'enllaços òptics preamplificats

**Autor:** Pere Sardà Carbasse

**Director:** Maria Concepción Santos Blanco

**Data:** 21 de gener de 2010

## Resum

En el context dels sistemes de comunicació per fibra òptica s'han proposat una gran varietat de tècniques de compensació de la dispersió, tant en el domini òptic com en l'elèctric, sempre buscant un compromís entre el cost i l'eficiència.

El propòsit d'aquest projecte és presentar una nova visió en el camp de la compensació de la dispersió, que té en compte que la dispersió és una distorsió de tipus lineal en el camp que es transmet per la fibra, però que es converteix en distorsió no lineal degut a la característica quadràtica típica del fotodíode. L'objectiu és obtenir un enllaç lineal extrem a extrem de forma que es puguin utilitzar equalitzadors lineals per a la compensació de la dispersió.

La tècnica proposada es basa en l'ús d'un mòdul electrònic en el receptor que incorpora una funció de transferència no lineal extreta d'un anàlisi matemàtic, combinada amb la utilització d'una modulació d'amplitud en el transmissor.

El document inclou un breu resum teòric sobre comunicacions òptiques, el disseny d'aquest mètode de linealització i la comprovació sobre una eina de software específica basada en comunicacions òptiques.

Aquest nou mètode basat en la generació d'harmònics en el receptor ens proporcionarà una millora en el nivells de distorsió no lineal comparat amb un sistema convencional basat en una Modulació d'Intensitat i Detecció Directa.

**Title:** Linearization techniques of preamplified optical links

**Author:** Pere Sardà Carbasse

**Director:** Maria Concepción Santos Blanco

**Date:** January, 18th 2010

## **Overview**

In the context of optical fiber communication systems a variety of dispersion compensating techniques have been proposed, into the optical and into the electrical domain, always facing a challenge between cost and efficiency.

This Master Thesis presents a new approach to chromatic dispersion compensation, based on the fact that dispersion is actually a linear distortion in the field transmitted through the fiber that is converted to nonlinear distortion due to the typical quadratic characteristic of photodiode. The goal is to obtain a linear end to end link in order to be able to use linear equalizers for the dispersion compensation.

The proposed technique is based on the use of an electronic module at the receiver incorporating a nonlinear transfer function extracted from mathematical analysis, in combination with the amplitude modulation at the transmitter.

This document includes a brief theoretical summary about optical communications, the design of this linearization method and the test on a specific software tool based on optical communications.

This new approach based on a harmonic generator device at the receiver provides improved dispersion-induced nonlinear distortion levels compared to conventional Intensity Modulation and Direct Detection system.

# CONTENTS

<b>INTRODUCTION</b> .....	<b>1</b>
<b>CHAPTER 1. BASIC THEORY</b> .....	<b>2</b>
<b>1.1. Transmitter</b> .....	<b>3</b>
1.1.1. Light source .....	3
1.1.2. External modulation .....	4
<b>1.2. Channel</b> .....	<b>5</b>
1.2.1. Phase velocity.....	6
1.2.2. Group velocity.....	7
<b>1.3. Receiver</b> .....	<b>8</b>
<b>CHAPTER 2. ADVANCED THEORY</b> .....	<b>10</b>
<b>2.1. Idea suggestion</b> .....	<b>10</b>
<b>2.2. Mathematical analysis</b> .....	<b>14</b>
<b>2.3. Software calculation</b> .....	<b>19</b>
<b>CHAPTER 3. SIMULATION</b> .....	<b>22</b>
<b>3.1. Transmitter modules</b> .....	<b>24</b>
<b>3.2. Receiver modules</b> .....	<b>27</b>
<b>3.3. Other modules</b> .....	<b>28</b>
<b>CHAPTER 4. RESULTS</b> .....	<b>32</b>
<b>4.1. Spectrum behaviour</b> .....	<b>33</b>
4.1.1. AM-HG.....	33
4.1.2. IM-DD .....	38
<b>4.2. Harmonics power level</b> .....	<b>40</b>
4.2.1. AM-HG.....	40
4.2.2. Comparison with IM-DD .....	41
4.2.3. Comparison with AM-SR .....	42
<b>CONCLUSIONS</b> .....	<b>46</b>
<b>FUTURE LINES</b> .....	<b>47</b>
<b>BIBLIOGRAPHY</b> .....	<b>48</b>
<b>ANNEX</b> .....	<b>49</b>



## INTRODUCTION

Optical fibers are very small diameter glass strands which are capable of transmitting an optical signal over great distances, at high speeds, and with extremely low signal loss as compared to standard wire or cable networks. Fiber optic systems provide significantly higher bandwidth and greater performance and reliability than standard copper wire systems.

The main limiting factors of fiber optics technology are attenuation and dispersion. Fiber attenuation is compensated for by Erbium Doped Fiber Amplifiers (EDFA) but nonlinear distortion arising from fiber dispersion limits the systems performance. To overcome this limitation it is worth noting that dispersion is in fact a linear effect in the optical field which only results in nonlinear distortion after square-law detection in the receiver. The use of linear equalizers could be advantageous to extend the dispersion induced frequency-length limit if the system was linear end-to-end.

The following document presents a new technique for the linearization of optical links which consists in the use of amplitude modulation (AM) and a nonlinear module after the photodetector. The function of this module is basically to generate harmonics of the detected signal that could be used to cancel the harmonics received. We will see that this technique called *Amplitude Modulation and Harmonics Generator* (AM-HG) effectively reduces the level of dispersion-induced harmonics at the receiver side with respect to conventional *Intensity Modulation and Direct Detection* (IM-DD) systems.

Chapter one summarizes some basic concepts related to optical communications, which are necessary to understand the concepts presented below.

Chapter two presents theoretical concepts related to the AM-HG optical transmission system. It also includes equations describing the signal treatment and a mathematical method to calculate the parameters of the harmonics generator (HG) module.

Third chapter shows the software implementation of the optical system considering the HG design defined in Chapter 2. To accomplish this task another software tool has been used, called VPIphotonics. This software simulates optical systems with great flexibility, including modular interface and parameter manipulation.

Last chapter shows the comparison between the software results obtained from the simulation of the IM-DD and the AM-HG systems, focusing on the harmonics power level relation. The AM-HG system is also compared to a similar linearizing method called *Amplitude Modulation and Square Root* (AM-SR), which performs an amplitude modulation system combined with a square root module at the receiver.

## CHAPTER 1. BASIC THEORY

First chapter aims at reviewing and clarifying the fundamental concepts required to develop and understand this master thesis explaining the basics of a typical optical communications system and its drawbacks.

An optical communications system comprises a transmitter of optical signals, a length of transmission optical fiber coupled to the source, and a receiver coupled to the fiber. Next figure shows the basic scheme of an optical communication system:

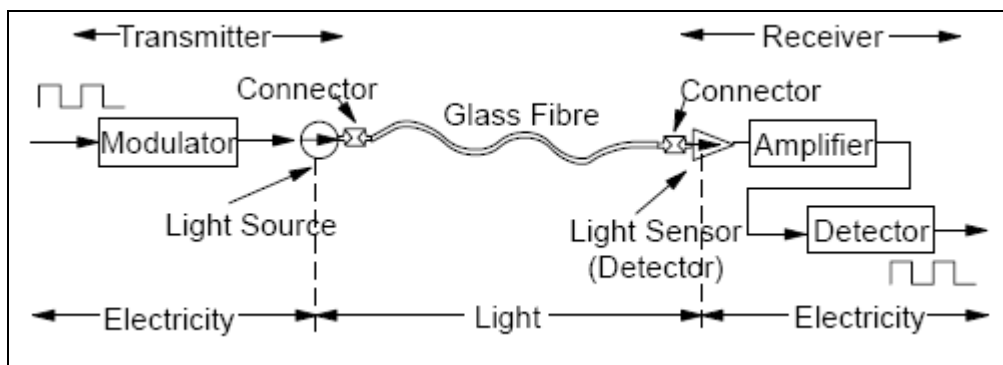

**Fig. 1.1** Optical communication sketch

The succession of events in the communication process is described below:

- A serial bit stream in electrical form is presented to a modulator, which encodes the data appropriately for fiber transmission.
- A light source (laser or Light Emitting Diode - LED) is driven by the modulator and the light focused into the fiber.
- The light travels down the fiber (during which it may experience dispersion and loss).
- At the receiver end the light is fed to a detector and converted to electrical form.
- The signal is then amplified and fed to another detector, which isolates the individual state changes and their timing. It then decodes the sequence of state changes and reconstructs the original bit stream.
- The timed bit stream so received may then be fed to a using device.



In order to describe the process accurately, the following paragraphs analyze the main parts of optical communication: Transmitter, channel and receiver.

## **1.1. Transmitter**

The most important functions performed in the transmission stage are light source generation and signal modulation. Both are described below:

### **1.1.1. Light source**

There are two kinds of devices that are used as light sources: Lasers and LEDs (Light Emitting Diodes). The physical principle involved in semiconductor lasers and LEDs is as follows. Electrons and holes recombine at the junction and this recombination results in electrons going from the high energy “conduction” band to the lower more stable “valence” band. This can result in either spontaneous (LED) or stimulated (LASER) emission depending on how the device is constructed.

Laser is an acronym for “Light Amplification by the Stimulated Emission of Radiation” and produces far and away the best kind of light for optical communication.

The key principle in laser operation is the principle of stimulated emission. For that phenomenon to be of relevance a condition known as population inversion is required in the material, i.e. the conduction band electron occupation should be higher to that in the valence band. That occurs above a certain feeding current known as threshold current.

Next figure shows a typical simplified configuration for direct signal modulation of the optical diode carrier. We see that above the threshold current there is a linear relation between the input current and the power emitted. We can obtain a linear power modulation (intensity modulation, IM) by biasing the diode above the threshold and injecting the signal as shown.

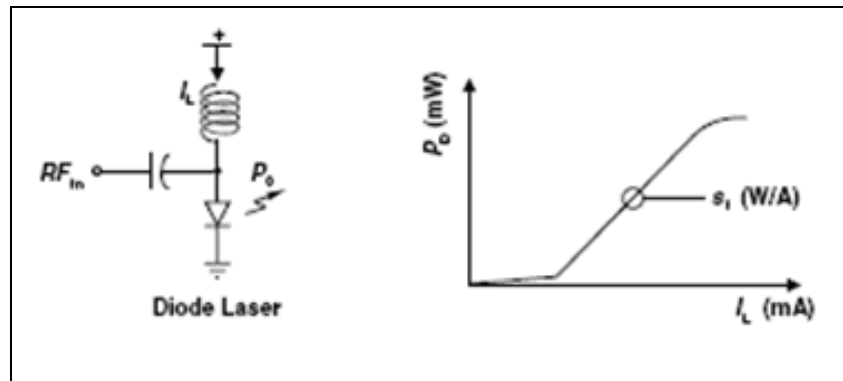

**Fig. 1.2** Direct modulation with diode laser transmitter

### 1.1.2. External modulation

In order to make light carry a signal, you have to introduce systematic variations in the light to represent the signal. Then, when the light is received you must decode it in such a way as to reconstruct the original signal.

There are different types of modulation depending on adjusted parameter. The most common in optical systems is intensity modulation (IM), but there is also amplitude, frequency and phase modulations. Frequency and phase modulations are rarely used.

Previous section (1.1.1) explained direct modulation. External modulation is accomplished by continuous biasing of the optical source and the use of an external device where the modulation takes place. It is of course more costly but it presents also a number of advantages.

The most common optical modulator consists of complementary electrically responsive optical phase shifters in each of two branches of an interferometer such as a Mach-Zehnder interferometer. These phase changes result in constructive and destructive interferences after the shift, obtaining the desired light power variation at the output. The optical modulator is interposed between the optical carrier source (a laser) and the communication channel (a fiber optic cable).

Next figure shows the most typical configuration for external modulation, composed by a laser light source working as the signal carrier, a radiofrequency signal working as the modulating signal and a Mach-Zehnder Modulator used as external modulator:

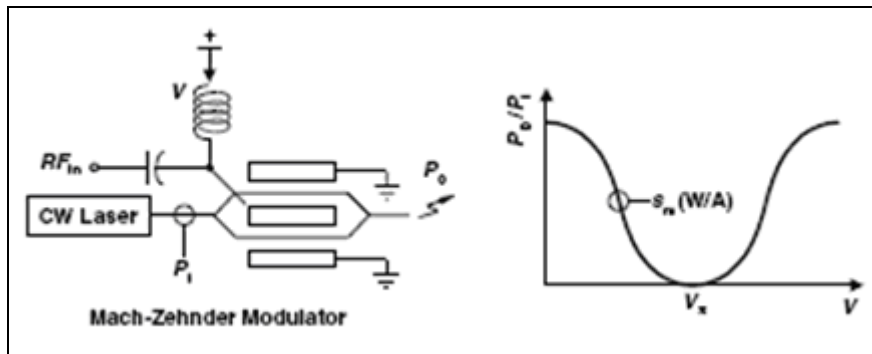

**Fig. 1.3** Intensity modulation with Mach-Zehnder modulator

Notice that the transfer characteristic of the modulator differs from that of the laser diode on the previous figure and it has to be adjusted to work on the linear region with small amplitude variations around it (small signal) to obtain an Intensity Modulation. The voltage fixed to work in the linear region is called the quadrature point marked in figure (1.3).

## 1.2. Channel

An optical signal becomes increasingly distorted as it travels along the fiber. This distortion is mainly a consequence of dispersion, which causes broadening of the transmitted light pulses as they travel along the channel. Consequently, the dispersive properties determine the limit of the information capacity of the fiber limiting the digital bit rate which must be less than the reciprocal of the broadened pulse duration. There are different dispersive mechanisms involved in the phenomenon of dispersion. These include intermodal and intramodal or chromatic dispersion. Long distance optical links use single-mode fiber, and thus intermodal dispersion is not present.

Chromatic dispersion results from the finite spectral linewidth of the optical source. Since real signals are limited in time, we have an input signal with a finite band of frequencies. The propagation delay difference between the different spectral components of the transmitted signal causes chromatic dispersion. Different colors of light (wavelengths) travel through the fiber at different speeds. Since the different colors of light have different velocities, some colors arrive at the fiber end before others. This delay difference is called the differential group delay, and leads to pulse broadening.

In order to define the chromatic dispersion some other dependent parameters have to be explained. The pulse propagating equation through a single-mode optical fiber is dependent on phase as follows:

$$X_{out}(\omega) = X_{in}(\omega) \cdot e^{j\phi(\omega)} \quad (1.1)$$

Where  $X_{out}(\omega)$  and  $X_{in}(\omega)$  are Fourier transform of input and output signal, and  $\phi(\omega)$  is the phase shift defined as:

$$\phi(\omega) = -\beta(\omega)z \quad (1.2)$$

With  $\beta$  defined as mode propagation constant and  $z$  the fiber length. So the wave propagation depends on the propagation mode constant.

The spectrum of the input signals of interest is usually limited to a frequency band  $\Delta\omega$  around the optical carrier  $\omega_0$ , such that  $\Delta\omega = \omega - \omega_0 \ll \omega_0$ , and therefore third and higher order terms in the Taylor expansion of  $\beta(\omega)$  can be neglected:

$$\beta(\omega) \approx \beta(\omega_0) + (\omega - \omega_0) \frac{\partial\beta}{\partial\omega} + \frac{(\omega - \omega_0)^2}{2} \frac{\partial^2\beta}{\partial\omega^2} + \dots = \beta_0 + \Delta\omega\beta_1 + \frac{\Delta\omega^2}{2}\beta_2 + \dots \quad (1.3)$$

These  $\beta$  coefficients are related with other basic parameters that define the dispersion behaviour. They are phase velocity, group velocity and group delay.

### 1.2.1. Phase velocity

Phase velocity can be defined as the propagation velocity of the carrier. Next equation defines relation with propagation mode constant:

$$V_{ph} = \frac{\omega_0}{\beta_0} = \frac{c}{n} \quad (1.4)$$

In vacuum, the phase velocity is independent of the optical frequency and equals the light velocity  $c$ . In a medium of refractive index  $n$ , the phase velocity is typically smaller by a factor  $n$ . This velocity concept lacks any physical sense as it refers to the velocity of a pure sine wave, which does not exist.

### 1.2.2. Group velocity

Group velocity is the velocity with which the overall shape of the wave amplitudes (known as the envelope of the wave) propagates through space. Next equation defines relation with  $\beta_1$ , where  $N$  is the group refractive index obtained by a derivative approximation:

$$V_g = \frac{1}{\beta_1} = \frac{\partial \omega}{\partial \beta} = \frac{c}{n + \omega \frac{\partial n}{\partial \omega}} = \frac{c}{N} = \frac{1}{\tau_g} \quad (1.5)$$

When the signal travels in the vacuum the group velocity has the same value than the phase velocity, but in a dispersive medium they are not equal due to the fact that the phase velocity varies as a function of the frequency. In a passband signal the group velocity is the velocity of the envelope. The parameter used to characterize the fiber is its inverse function, the group delay  $\tau_g$ .

Chromatic dispersion in fiber is usually defined through the dispersion parameter  $D$  (ps/nm·km), which is the variation in group delay with wavelength:

$$D = \frac{\partial \tau_g}{\partial \lambda} = \frac{\partial \omega}{\partial \lambda} \beta_2 \quad (1.6)$$

Considering as a whole all the aspects influencing on fiber behaviour, including the dispersion parameter, the chromatic dispersion index is defined as follows:

$$\chi = \frac{\pi}{c} \cdot D \cdot L \cdot \lambda^2 \cdot f^2 \quad (1.7)$$

Where  $L$  is fiber length,  $D$  is dispersion parameter,  $\lambda$  is the carrier wavelength and  $f$  is the modulating frequency.

Related with the physical characteristics of the fiber optic material, usually silica, the emission frequency in the thesis simulations has been fixed to 193 THz matching the third window wavelength at  $\lambda = 1550 \text{ nm}$ . The third window is the

most widely used actually and has the lowest attenuation losses and hence it achieves the longest range.

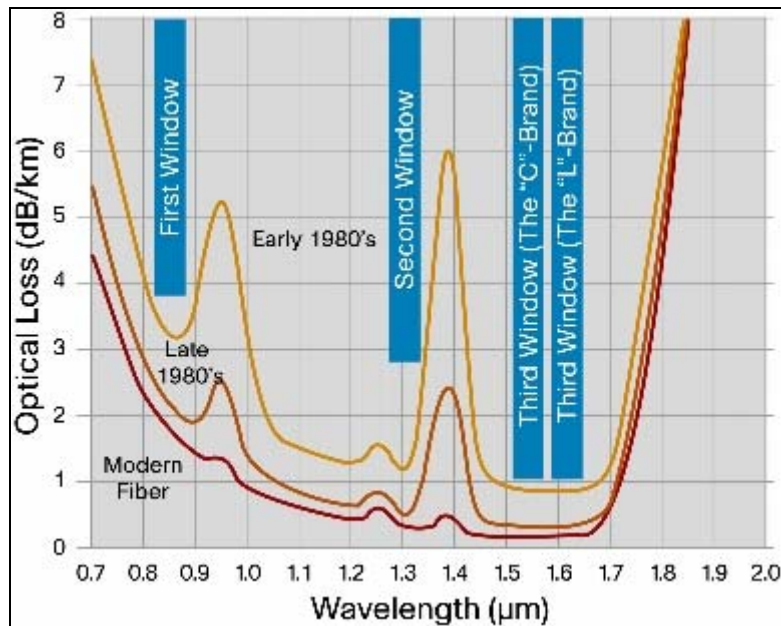

**Fig. 1.4** Silica attenuation

### 1.3. Receiver

The main component of an optical receiver is a photodetector, which converts light into electricity using the photoelectric effect. The photodetector is typically a semiconductor-based photodiode. Several types of photodiodes include P-N photodiodes, P-I-N photodiodes, and avalanche photodiodes (APD). They need to be inversely polarized. Next figure shows the physical photodetection process using semiconductor material:

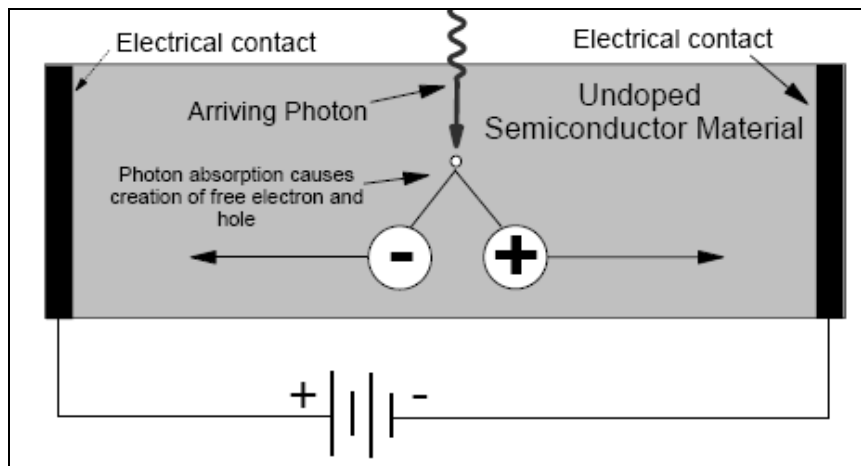
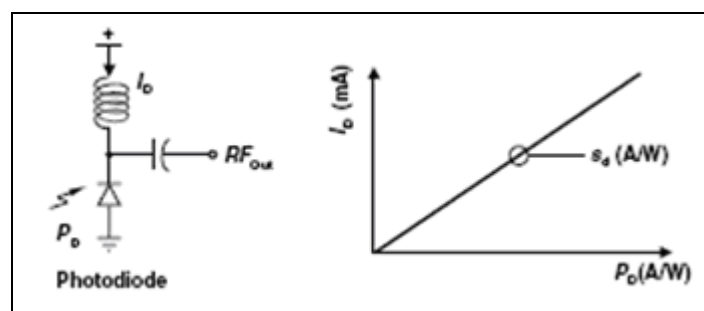

**Fig. 1.5** Semiconductor photodetector principle

The detection process is based on the square-law rule which means that the output diode current  $I$  is proportional to the squared modulus of the electric field associated to the optical wave  $E$ , or mean optical power  $P$ . Next equation shows this relation:

$$i_d = |E_R|^2 \quad (1.8)$$

Next figure shows a typical detection stage configuration and its transfer characteristic:



**Fig. 1.6** Photodiode detector

As seen, the characteristic input power - output current is linear. The slope of this characteristic is known as responsivity or conversion efficiency and depends on the reverse voltage applied to the photodiode.

## CHAPTER 2. ADVANCED THEORY

This chapter introduces the concepts behind the harmonics generator method. Subjects discussed in chapter two include idea suggestion, mathematic development and calculation implemented to perform the system.

### 2.1. Idea suggestion

The most common modulation applied in fiber optical communication is intensity modulation (IM). This type of modulation is usually performed in advanced long distance and high capacity links with a laser source, a radiofrequency signal source and Mach-Zehnder interferometer functioning as an external modulator. Next figure shows the block diagram of an intensity modulation system:

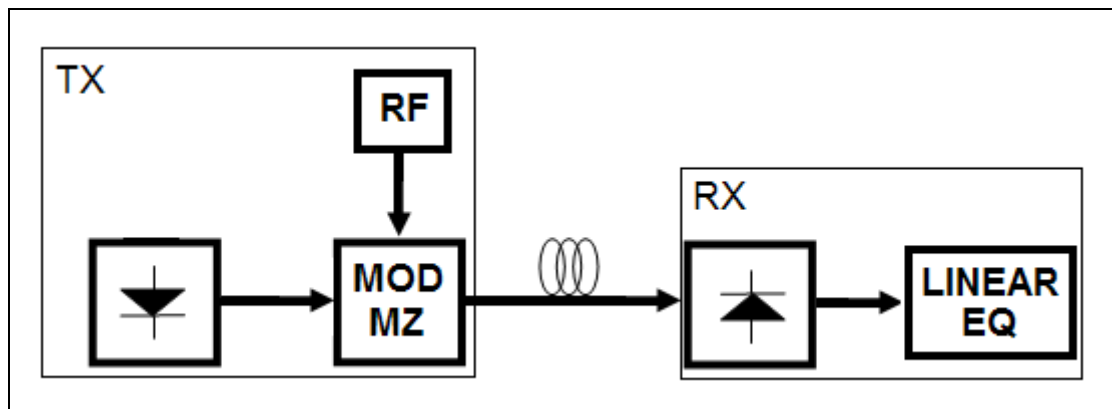

**Fig. 2.1** Intensity modulation diagram

Spectrally this kind of modulation generates harmonics of the radiofrequency modulating signal, distributing power and information at these frequencies. The next figure shows a typical spectrum of an intensity modulation link, this time with the modulating signal at 7GHz and generating harmonics at  $\pm 14$  GHz, and  $\pm 21$  GHz...etc.:



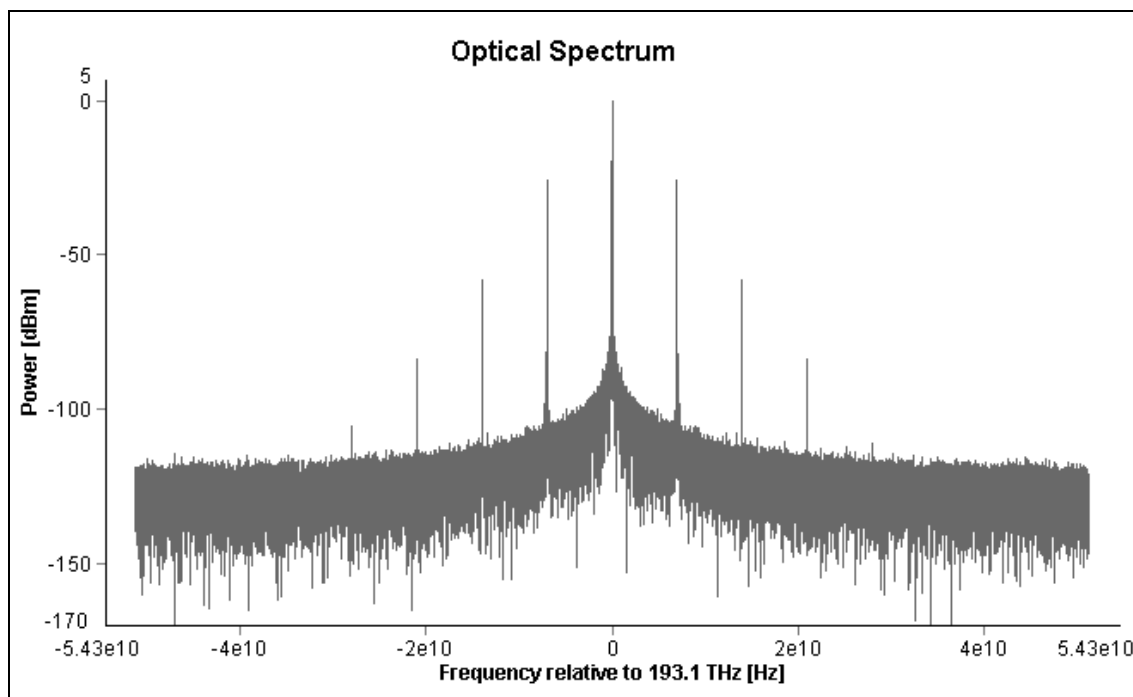

**Fig. 2.2** Intensity modulation spectrum

An intensity modulation at the transmitter combined with a direct detection system at the receiver constitute an ideal system by nature because they perform inverse functions, but dispersion affects all the transmitted frequencies and induces nonlinear distortion.

In an ideal case, a regular linear equalizer should compensate for linear distortion but nonlinearities induced by the combined effect of the fiber dispersion and the square law rule performed at the detector suggest the use of another electrical module to compensate nonlinear factors.

An idea to reduce the nonlinearities could be to eliminate the number of harmonic components in spite of generation of new linear distortion that could be easily compensated by equalizers.

The harmonic generator is the idea suggested to solve this drawback. This method is better implemented in conjunction with a pure AM modulation and also it is more convenient from the fiber propagation viewpoint.

The method introduces a polynomial function over the received signal that for the pure AM modulation only has components at the fundamental frequency and its second harmonic.

The goal is then to try to reduce the second harmonic level through generation of a new second harmonic by electrically squaring the received signal and applying a proper weight (polynomial coefficient). This squaring generates terms at the third harmonic with a lower level than the incoming second

harmonic so a cube over the incoming signal with the proper weight can be used to cancel for this newly generated third harmonic and so on and so forth. More details and the exact explanation of the technique are found in the software calculation section (2.3).

To obtain an amplitude modulation a predistorter circuit (PD) is required in combination with direct laser modulation or else using an external modulator. Next figure shows the block diagram of an amplitude modulation using direct modulation, including the harmonic generator (HG) in the receiver stage:

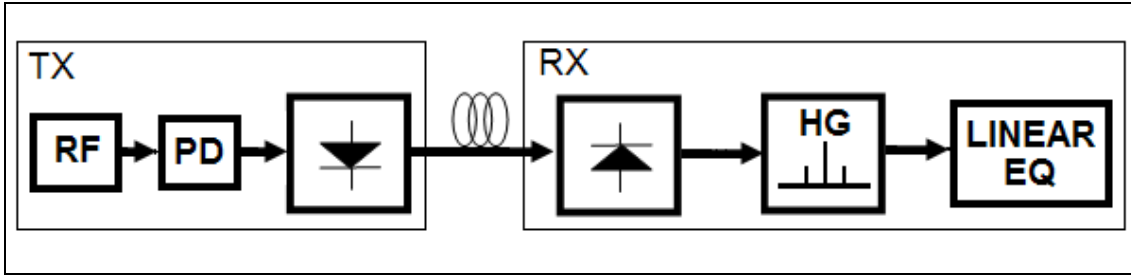

**Fig. 2.3** Amplitude modulation diagram

The radiofrequency signal supplies the information and acts as the modulating wave, while the light signal acts as the carrier wave. Next equation represents these signals contribution, where  $V_c$  refers to carrier wave amplitude,  $V_m$  is the modulating wave amplitude,  $f_c$  is the carrier frequency and  $f_m$  is the modulating wave frequency:

$$\begin{aligned} V_c(t) &= V_c \sin(2\pi f_c t) \\ V_m(t) &= V_m \sin(2\pi f_m t) \end{aligned} \quad (2.1)$$

The amplitude term has been replaced with the combination of the original amplitude plus the information signal. The modulated signal amplitude expression  $v(t)$  will be:

$$v(t) = V_c \sin(2\pi f_c t) + \frac{m \cdot V_c}{2} \cos[2\pi(f_c - f_m)t] - \frac{m \cdot V_c}{2} \cos[2\pi(f_c + f_m)t] \quad (2.2)$$

The amount of modulation depends on the amplitude of the information signal. This is usually expressed as a ratio of the maximum information signal amplitude to the amplitude of the carrier. We define the modulation depth according to next equation:

$$m = \frac{\text{MAX}[V_m(t)]}{V_c} \quad (2.3)$$

The interpretation of the modulation depth,  $m$ , may be expressed as the fraction (percentage if multiplied by 100) of the carrier amplitude that it varies by. If  $m=0.5$ , the carrier amplitude varies by 50 % above and below its original value. If  $m=1.0$  then it varies by 100%. Next figure shows the signals involved in an amplitude modulation:

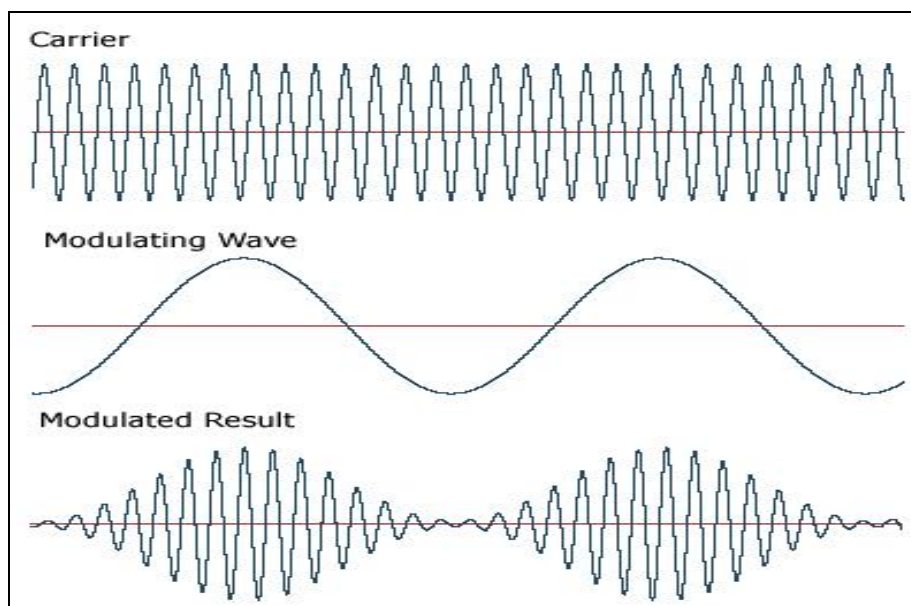

**Fig. 2.4** Amplitude modulation signals

Considering the previous expression of the modulated signal result, three terms can be observed. One at the carrier frequency  $f_c$  with an amplitude value equal to  $V_c$ , and symmetric terms at the carrier frequency plus  $(f_c + f_m)$  and minus  $(f_c - f_m)$  the modulating frequency with an amplitude value equal to  $m \cdot V_c / 2$ . So the spectrum of an amplitude modulation will be like the next figure:

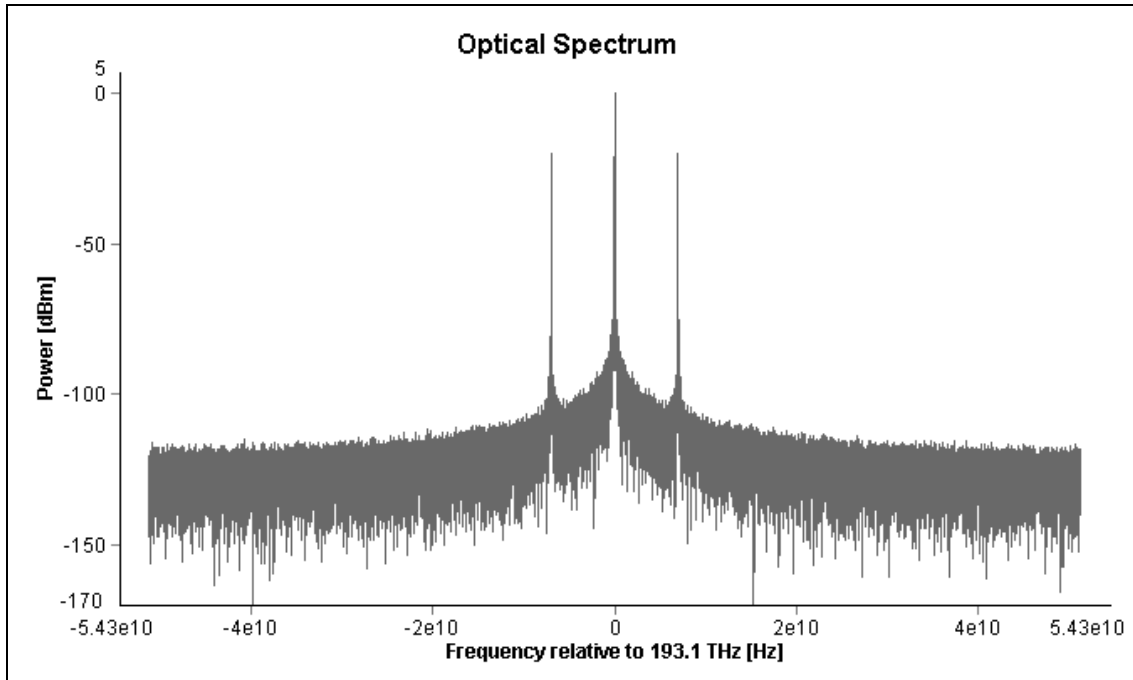

**Fig.2.5** Amplitude modulation spectrum

Comparing the amplitude modulation (AM) spectrum with the intensity modulation (IM) spectrum we can appreciate some advantages. Firstly the amplitude modulation consumes smaller bandwidth than IM. On second place the AM spectrum has less harmonics but with higher power rate. That means a softer influence of dispersion on the transmitted signal, and a better signal recovery at the receiver.

For all the reasons it is convenient to use AM modulation.

## 2.2. Mathematical analysis

Firstly the main interest is to obtain the equation at the harmonic generator input to determine the module design. Next equation shows fiber input optical field for an ideal amplitude modulation:

$$E_{AM}(t) = [1 + m \cdot \cos(\omega t)] e^{j\omega_0 t} \quad (2.4)$$

Where  $m$  represents the modulation depth,  $\omega$  is the modulating frequency and  $\omega_0$  is the optical frequency.

The optical field along the fiber receives its influence, defined as the transfer function:

$$H(f) = e^{-j\chi} \quad (2.5)$$

Where  $\chi$  is the dispersion chromatic index defined previously in chapter one. Then the field under fiber influence arrives at the photodetector. Next equation show the output current extracted from the photodetector  $I_D(t)$  after applying the detection quadratic law. The optical field at the photodetector input  $E_R(t)$  will be the convolution product between the original field  $E(t)$  and the fiber transfer function converted to the time domain  $h(t)$ . The current obtained also depends on the responsivity factor of the photodetector  $\mathfrak{R}$  and the fundamental power value  $P_0$ :

$$I_D(t) = \mathfrak{R} \cdot P_{opt} = \mathfrak{R} \cdot P_0 \cdot |E(t) * h(t)|^2 = \mathfrak{R} \cdot P_0 \cdot |E_R(t)|^2 = \mathfrak{R} \cdot P_0 \cdot |1 + 2m \cdot \cos(\omega t) \cdot e^{j\chi}|^2 \quad (2.6)$$

Developing the optical field squared and applying trigonometric identities the result obtained is:

$$\begin{aligned} I_D(t) &= \mathfrak{R} \cdot P_0 \cdot \left( [1 + m \cdot \cos(\chi) \cdot \cos(\omega t)]^2 + m^2 \cdot \sin^2(\chi) \cdot \cos^2(\omega t) \right) \\ I_D(t) &= \mathfrak{R} \cdot P_0 \cdot \left( 1 + \frac{m^2}{2} + 2 \cdot m \cdot \cos(\chi) \cdot \cos(\omega t) + \frac{m^2}{2} \cdot \cos(2\omega t) \right) \end{aligned} \quad (2.7)$$

The polynomial module is easier to implement with only the time-varying part of the signal, so in this analysis the direct current offset (DC) terms have been eliminated. to give this current expression:

$$I_D(t) = \mathfrak{R} \cdot P_0 \cdot \left( 2 \cdot m \cdot \cos(\chi) \cdot \cos(\omega t) + \frac{m^2}{2} \cdot \cos(2\omega t) \right) \quad (2.8)$$

This is in contrast with other approaches which require accurate treatment of the CW part of the signal [5].

Now simplification requires the extraction of a common factor and group these three constant terms including the responsivity and the fundamental power. This group of constant terms is called  $\gamma$  and has voltage units. Its value will depend on the arriving voltage and can be fixed to any value by using amplifiers and attenuators. We will see this is a key parameter in our system.

Since it has been generated through square-law photodetection of a pure AM signal affected by fiber dispersion the input voltage  $V_{IN}$  to the harmonic generator can be written as:

$$V_{IN}(v) = \gamma(v) \cdot [k \cdot \cos(\chi) \cdot \cos(\omega t) + \frac{k^2}{4} \cdot \cos(2\omega t)] \quad (2.9)$$

The modulation depth  $m$  is substituted by parameter  $k$  due to constants nomenclature.

The goal is to obtain a desired voltage at the harmonic generator output  $V_{OUT}$ , manipulating the voltage arriving in the device  $V_{IN}$  multiplying by the  $\alpha$  coefficients imposed by the harmonic generator and defined in the next equation:

$$V_{OUT} = V_{IN} + \alpha_1 V_{IN}^2 + \alpha_2 V_{IN}^3 + \alpha_3 V_{IN}^4 + \dots \quad (2.10)$$

In terms of dimensionless variables input  $x$ , output  $y$  and the dimensionless coefficients  $r$  are represented as:

$$y = x + r_1 x^2 + r_2 x^3 + \dots \quad (2.11)$$

In this case the dimensionless input  $x$  is defined as:

$$x = k \cdot \cos(\chi) \cdot \cos(\omega t) + \frac{k^2}{4} \cdot \cos(2\omega t) \quad (2.12)$$

Remember the device input voltage includes the voltage  $\gamma$  that depends on the device input power. The calculation of the linearizer coefficients will be affected by this fact.

The output voltage will be influenced by gamma voltage according to the next equation:

$$V_{OUT}(v) = \gamma(v) \cdot y \quad (2.13)$$

If gamma is multiplied at both sides of (2.11) the dimensionless linearizer expression the next equation is obtained:

$$\gamma y = \gamma x + r_1 \gamma x^2 + r_2 \gamma x^3 + \dots \quad (2.14)$$

According to previous definitions the linearizer input and output can be described as:

$$\begin{aligned} V_{IN} &= \gamma x \\ V_{OUT} &= \gamma y \end{aligned} \quad (2.15)$$

If we consider the definitions of the input and output voltage depending on gamma and substitute their values on (2.10), the expression obtained is:

$$V_{OUT} = V_{IN} + \frac{r_1}{\gamma} V_{IN}^2 + \frac{r_2}{\gamma^2} V_{IN}^3 + \frac{r_3}{\gamma^3} V_{IN}^4 + \dots \quad (2.16)$$

Finally the dependence of the gamma voltage on the harmonic generator coefficients  $\alpha$  can be described by:

$$\alpha_i = \frac{r_i}{\gamma^i} \quad (2.17)$$

This last equation denotes the need to control the input power level to fix the value of gamma voltage. If this value is not fixed the coefficients for the harmonic generator should be recalculated for each power variation and the complexity of the system will increase.

The solution proposed consists on applying a gain  $G$  before the harmonics generator input to obtain the desired power level to fix the gamma voltage. To calculate the suitable gain we need to make the measurement of the fundamental harmonic power  $P_0$ , the fundamental harmonic voltage  $V_{1H}$  and the second harmonic voltage  $V_{2H}$  for a known chromatic index  $\chi$ . The next equation shows these harmonics contribution considering the amplifier gain:

$$\begin{aligned} V_{1H} &= \Re \cdot P_0 \cdot 2m \cdot \sqrt{G} \cdot \cos(\chi) \\ V_{2H} &= \Re \cdot P_0 \cdot \frac{m^2}{2} \cdot \sqrt{G} \end{aligned} \quad (2.18)$$

Since the received power depends on  $\chi$ , we calculate the harmonics generator coefficients so to minimize the harmonics content at a specified value of  $\chi$ . In this case we choose to do it for  $\chi=0$  but other options can be explored in future research. Then the cosine in equation (2.18) can be neglected.

The gamma voltage depends on the harmonic values and substituting the previous equation we obtain the variation on the amplifier gain:

$$\gamma = \frac{V_{1H}^2}{4 \cdot V_{2H}} = 2 \cdot \Re \cdot P_0 \cdot \sqrt{G} \quad (2.19)$$

For the simulations in this work the gain value applied on the electric amplifier will be calculated fixing the value of gamma to  $\gamma=1V$ , considering a responsivity  $\Re=1A/W$  and the measured value of  $P_0$ , the optical carrier power level. The calculated gain can be checked measuring the voltage values and applying expression (2.19) to obtain a  $\gamma=1V$ .

At the receiver input an optical amplifier is considered so that a constant optical input is maintained regardless of power losses in the fiber or other elements.

We will see through simulations that this optical amplifier set the total optical power (including the carrier and sidebands) at the input to the specified value, while the expression for gamma depends only on the carrier power. Depending on the modulation depth used small corrections to the gain should be introduced in order to get  $\gamma=1V$ .



### 2.3. Software calculation

The calculation of the coefficients requires a powerful mathematical tool to perform Taylor and Fourier series, so the use of MATLAB seems the most suitable option.

With the gamma trouble solved, the equation obtained from the input voltage is defined in the code as:

$$V_{IN} = k \cdot \cos(\chi) \cdot \cos(\omega t) + \frac{k^2}{4} \cdot \cos(2\omega t) \quad (2.20)$$

The MATLAB program can be made to calculate any number of coefficients, provided the computer system has enough calculating resources. Here we have been able to calculate up to 15. Taking the harmonic generator output voltage equation:

$$V_{OUT} = V_{IN} + \alpha_1 V_{IN}^2 + \alpha_2 V_{IN}^3 + \alpha_3 V_{IN}^4 + \dots + \alpha_{15} V_{IN}^{16} \quad (2.21)$$

Substituting the  $V_{IN}$  for the pure AM modulation expression (2.20), it is seen that different new harmonics will appear at higher frequencies, as a result of the exponentiation operation applied on  $x$ , and all of them will be multiples of the fundamental frequency. The polynomial coefficients should be calculated so that each of the contributions cancel each other. This is the reason of the improvement in the relation between the fundamental and the other harmonic components. The equation obtained after the  $V_{IN}$  substitution, expression (2.21), can be casted into the form as:

$$V_{OUT} = g_1 \cdot \cos(\omega t) + g_2 \cdot \cos(2\omega t) + g_3 \cdot \cos(3\omega t) \quad (2.22)$$

The analysis have been limited to the first three harmonic frequencies because the second and third harmonics cause the most serious interferences and higher frequencies use to have lower values, so they are likely to be under the noise level.

Fourier series is a mathematic tool used to express periodic functions in a sum of oscillating functions, usually sine and cosine functions. The Fourier series also can calculate the values of the coefficients  $a_n$  associated to these cosines at different frequencies  $n$ , using the expression:

$$a_n = \frac{1}{\pi} \int_{-\pi}^{\pi} f(x) \cdot \cos(nx) dx, n > 0 \quad (2.23)$$

The use of the Fourier series allows to discriminate which numeric constant is multiplying a cosine function of a given frequency  $\cos(\omega t)$ . With this tool we can determine the expressions for the  $g_i$  unknowns. By inspection, we can see that these unknowns will have a structure like:

$$\begin{aligned} g_1 &= k \cdot \cos(\chi) \\ g_2 &= k^2 (gg_{2\_20} + gg_{2\_22} \cdot \cos(2\chi)) + \\ &+ k^4 (gg_{2\_40} + gg_{2\_42} \cdot \cos(2\chi) + gg_{2\_44} \cdot \cos(4\chi)) + k^6 \dots \\ g_3 &= k^3 (gg_{3\_31} \cdot \cos(\chi) + gg_{3\_33} \cdot \cos(3\chi)) + \\ &+ k^5 (gg_{3\_51} \cdot \cos(\chi) + gg_{3\_53} \cdot \cos(3\chi) + gg_{3\_55} \cdot \cos(5\chi)) + k^7 \dots \end{aligned} \quad (2.24)$$

In (2.24) it can be seen how the subindexes are assigned to each numerical constant  $gg$ . For example for the  $gg_{2\_42}$  constant, the first subindex indicates that the constant belongs to  $\cos(2\omega t)$  multiplying factor,  $g_2$ . The second subindex indicates that the constant is included in the addition factor multiplying a  $k^4$  term. Finally the third subindex indicates the constant is multiplying a  $\cos(n\chi)$  factor whose cosine inside term is  $2\chi$ .

Next step to get the coefficients values  $gg$  is to obtain the expression related to each  $k$  exponentiation factor.

Taylor series are regularly used to make an approximation of a function  $f(x)$  at a given point  $a$ , giving a polynomial expression such as:

$$f(x) = f(a) + \frac{f'(a)}{1!} (x-a) + \frac{f''(a)}{2!} (x-a)^2 + \dots + \frac{f^n(a)}{n!} (x-a)^n \quad (2.25)$$

In this particular case it gives flexibility to obtain the parts of the equation related to a single exponentiation value of  $k$ . For example, to obtain all the terms

related with  $k^4$  we can perform the Taylor approximation of 5<sup>th</sup> order, and subtract the Taylor approximation of 3<sup>rd</sup> order. Remember the Taylor expression can be performed for a fixed grade  $n$ .

The last step to obtain the values for the  $gg$  unknowns is to discriminate the constants multiplied by each  $k$  exponentiation factor. Note that each  $gg$  constant is associated to a cosine term  $\cos(n\chi)$ , where  $n$  is a natural number including zero.

In this case the Fourier series will be used again to discriminate the values associated to each cosine term.

The equations obtained from the sum of the  $gg$  contribution parameters will be matched to zero, for  $\chi = 0$ . Any other interesting value for  $\chi$  could be used. The resulting equations will have two variables,  $k$  and the final coefficients  $\alpha_i$ .

The arbitrary parameter  $k$  which is related to the modulation depth, will have different exponentiation factors, but in each case it can be extracted as a common factor and eliminated from the equation. This is so because the system has to work for any modulation depth value.

It is worth noting here that the zero means that the harmonics cancellation has residual terms at  $k^n$  where  $n$  is the maximum polynomial order plus one. Therefore the higher the modulation depth used, the higher the residual harmonic levels obtained with this technique. Or else, if the system has to work with very high modulation depths and very low harmonic levels then it needs to use a lot of polynomial terms in the HG module. In this work we have always used 15 terms in the MATLAB program calculation which means a polynomial of order 16, therefore the residual harmonic levels should be of order  $k^{17}$ .

With the  $\alpha_i$  coefficients as single variable in each equation, they can be calculated clearing the equation from  $\alpha_1$  to  $\alpha_{15}$ .

For a better understanding the MATLAB code for the program can be found in the Annex. Note that some of the variables used are renamed on the original code, for example the  $\alpha_i$  coefficients have been defined as  $r_i$ .

The coefficients obtained from the MATLAB program calculation will be introduced in the harmonic generator with a fixed number of 14 decimals.

## CHAPTER 3. SIMULATION

This chapter deals with the simulation software implementation of the AM-HG method. The software selected is VPIPhotonics and its main characteristics are described in the following lines. This software offers a flexible environment to support requirements in optical component and systems design.

The VPIphotonics software offers a combination of a friendly graphical interface, a sophisticated simulation scheduler and a flexible optical signal representation enabling an efficient modeling of optical links.

The software also uses modular representation and permits to create and design your own modules to personalize your link performance. Parameterized signals, noise bins and distortions facilitate efficient modeling of complex systems and they allow the tracking, visualization and analysis of signal properties along a link.

This chapter explains the virtual assembly of the AM-HG method, defining the modules used in the software and their configuration and relating them with real devices. The system modular explanation is divided in two main stages, transmitter and receiver. Other modules are used with less relevance to plot information or simulate the fiber link. Next figure shows the complete scheme of the whole system including these parts:

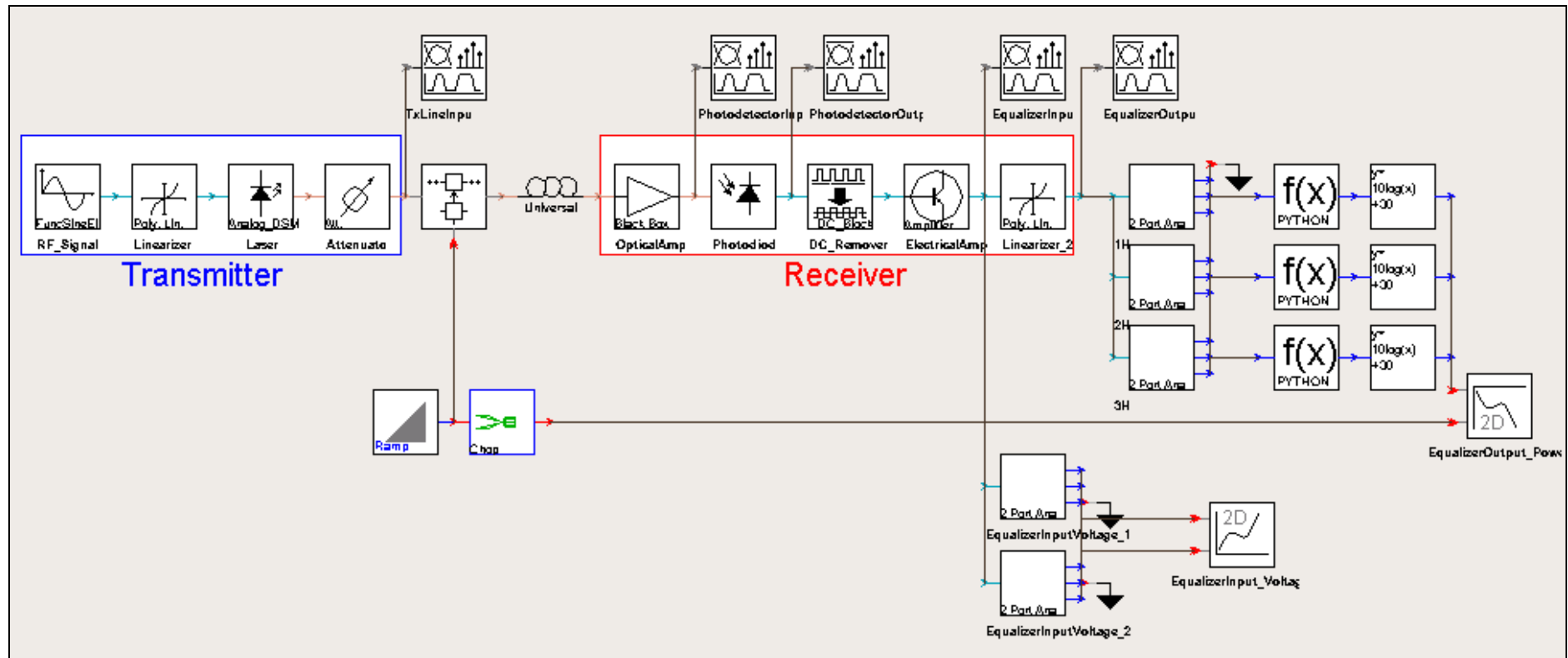
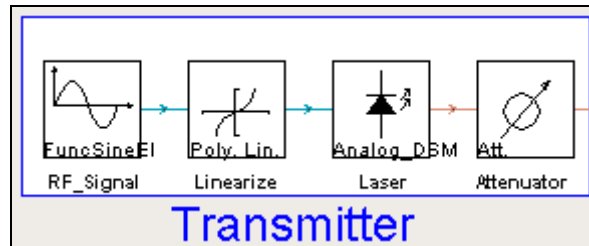

Fig. 3.1 AM-HG simulation scheme

Modules in the blue square correspond to transmitter, modules in the red square correspond to receiver, and the rest are analyzing and visualizing modules used to generate and plot the information obtained from the link performance. Next sections analyze these parts specifically.

### 3.1. Transmitter modules

The transmitter generates an amplitude modulation and injects the resulting signal into the fiber. The modules used to perform the transmitter system are shown in the next figure and described below:



**Fig. 3.2** Transmitter scheme

**Electrical Sine Generator:** This first module generates an electrical sine waveform working as the modulating signal. The amplitude  $V_0$  and initial phase  $\varphi$  of the signal can be adjusted respectively. In this case the chosen frequency  $f$  has been 7 GHz as a convenient value and to facilitate the comparison between other nonlinear correcting methods [5]. The module also permits to set an offset applied to the signal fixing a value for  $V_{BIAS}$  parameter. The electrical output signal of the module is determined by the equation:

$$V_{out} = V_{BIAS} + V_0 \sin(2\pi ft + \varphi) \quad (3.1)$$

**Polynomial Linearizer:** This module evaluates a polynomial function using the arriving signal as the input variable. It can be used to apply linearization functions to drive waveforms to modulators and lasers. This module can be used to formulate any form of memoryless linearizer.

In this case the module is used to simulate an amplitude modulation (AM), because VPIPhotonics software does not offer any module to perform this kind of modulation. It will be used as a signal predistorter module to obtain AM laser direct modulation.

**Analog Laser:** This module models a laser optical source working as the carrier signal. Uses datasheet parameters to describe the laser including relative intensity noise, linewidth, driver transconductance, dynamic and

adiabatic chirp, laser bias and slope efficiency. In this case the emission frequency is fixed to 193 THz.

With the previous modules explained is time to justify the parameters chosen for the AM modulator design. The equation of the optical output power ( $P_{opt}$ ) emitted by the laser source has to follow the expression:

$$P_{opt} = P_{BIAS}(1 + x(t)) = P_{BIAS}(1 + m_l \cdot V_{IN}) \quad (3.2)$$

Where signal  $x(t)$  is the radiofrequency signal generated by the electrical source,  $V_{IN}$  is the voltage signal obtained at the predistorter output and  $m_l$  is the laser modulation depth defined by the laser diode characteristics. Next figure shows the block diagram:

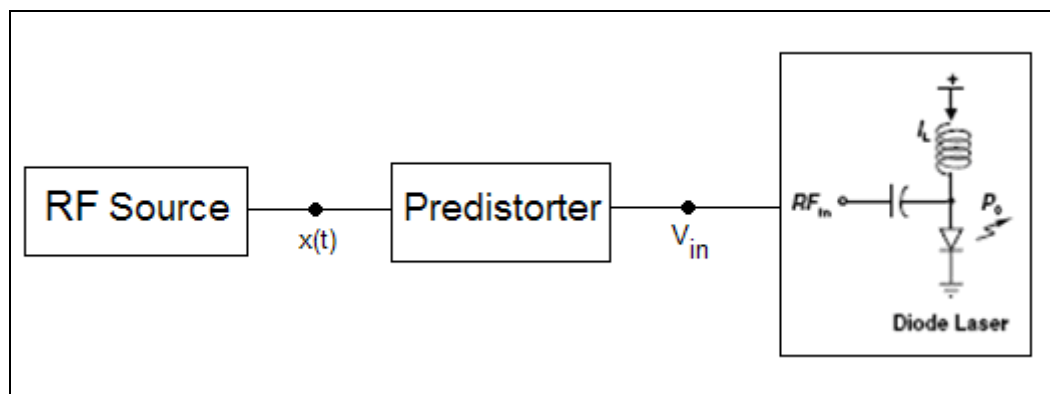

**Fig. 3.3** Amplitude modulator sketch

Considering the next figure, the defining parameters of the laser diode are Power Bias ( $P_{BIAS}$ ), Driver Transconductance ( $DT$ ), Bias Current ( $I_{BIAS}$ ), Threshold Current ( $I_{th}$ ) and Slope Efficiency ( $S$ ):

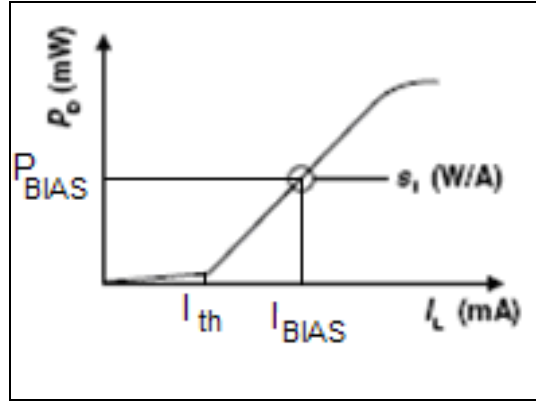

**Fig. 3.4** Optical source transfer characteristic

Next equation represents the optical power output obtained from the laser diode parameters:

$$P_{opt} = P_{BIAS} (1 + m_l \cdot V_{IN}) = P_{BIAS} \left(1 + \frac{DT}{I_{BIAS} - I_{th}} \cdot V_{IN}\right) \quad (3.3)$$

Assigning typical laser diode values to the parameters, the optical power output selected here is:

$$P_{opt} = P_{BIAS} \left(1 + \frac{0.04 \text{ A/V}}{60 \text{ mA} - 20 \text{ mA}} \cdot V_{IN}\right) = P_{BIAS} (1 + V_{IN}) \quad (3.4)$$

To obtain the electric field  $E_{opt}$  launched into the optical link the laser performs a square operation on the optical output power  $P_{opt}$ . Comparing the output expressions the required laser input voltage  $V_{IN}$  can be obtained as a function of the radiofrequency signal  $x(t)$ . This expression will determine the equation defining the input voltage applied on the laser, i.e. the predistorter circuit polynomial:

$$\begin{aligned} E_{opt} &= \sqrt{P_{BIAS}} \sqrt{1 + V_{IN}} = \sqrt{P_{BIAS}} (1 + x(t)) \\ 1 + V_{IN} &= (1 + x(t))^2 \\ V_{IN} &= 2x(t) + x^2(t) \end{aligned} \quad (3.5)$$



So finally the values for the predistorter coefficients to obtain a correct amplitude modulation will be extracted from the last equation (0, 2 and 1) for a second grade polynomial performed by the polynomial linearizer module.

**Attenuator:** This last transmitter module attenuates an optical signal. The input field ( $E_{in}$ ) is attenuated by a factor  $x$  introduced in decibels, as follows:

$$E_{out} = E_{in} \cdot 10^{-\frac{x(dB)}{20}} \quad (3.6)$$

This module is used to normalize the power value to 0 dBm (1mW), to minimize the nonlinear effects caused by a non realistic power value at the fiber input.

### 3.2. Receiver modules

At the receiver stage the signal is amplified, photodetected and modified to obtain the desired improvements provided by the harmonics generator. This stage is made by five modules as shown in the following figure. The modules detailed explanation is also below:

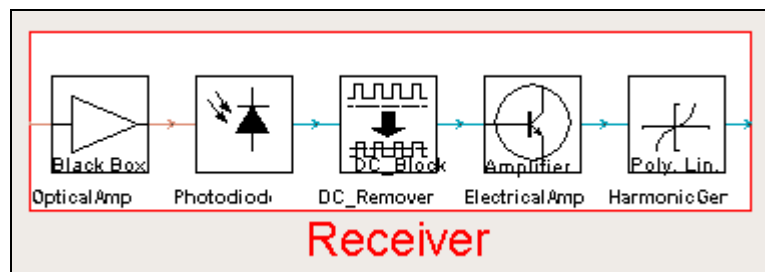

**Fig. 3.5** Receiver scheme

**Optical amplifier:** This module simulates an optical amplifier based on introduced data like power gain, noise, accuracy or polarization effects. The output power is fixed to 10 dBm to make a more realistic simulation and also to simplify the calculation of harmonic generator coefficient values on MATLAB software.

**Photodiode:** This module simulates the conversion of light into electricity due to the photoelectric effect. The output current is described by sum of photocurrent, dark current, shot and thermal noise. The output is simulated on

base of predefined responsivity, avalanche multiplication, dark current and noise.

**Continuous Wave Remover:** This module removes the direct current offset (DC) content from an electrical signal. It acts as an infinite-capacity capacitor.

The output electrical signal,  $V_{out}(t)$ , is formed from the input signal,  $V_{in}(t)$  by subtracting the mean value of the input signal from the time-varying input signal. This can be written as follows:

$$V_{out}(t) = V_{in}(t) - \langle V_{in}(t) \rangle \quad (3.7)$$

This operation is basic to ensure a correct performance at the harmonics generator module because the continuous wave has a direct effect on the coefficient values calculation and should be suppressed to perform the method.

**Electrical Amplifier:** This module is a system model of an electrical amplifier with additive Gaussian white noise source at its output. His value is adjusted in agreement with the input optical amplifier to obtain the required value at the harmonic generator input.

**Harmonic Generator:** The module evaluates a polynomial function, but this time using the coefficient values calculated previously with the mathematical engine (section 2.3). This evaluation will generate new harmonics, cancelling the harmonics with a biggest influence and improving the power relation between nonlinear interferences and the frequency which carries the useful information.

### 3.3. Other modules

The most important module outside of the transmitter and receiver stages is the fiber simulator. The rest of the modules used in the simulation belong to analyzing, visualizing or collecting information tasks. All of them are explained below:

**Universal Fiber Module:** The Universal Fiber module simulates a wideband nonlinear signal transmission in optical fibers with piecewise constant parameters specified for each fiber span individually, taking into account unidirectional signal flow, stimulated and spontaneous Raman scattering, Kerr nonlinearity and dispersion.

**Optical and Electrical Signal Analyzer:** This module is the most commonly used to visualize results. It works as an interface tool that is used to display and analyze electrical and optical signals. It provides the functionality of several visualizing and analyzing tools like an optical spectrum analyzer, optical and

electrical oscilloscopes, radio-frequency spectrum analyzer, eye diagram analyzer and BER estimator.

**Two-Port Electrical Analyzer:** This module performs identifies the magnitude of a single frequency component of an input signal. In the harmonic generator assembly is useful to extract the amplitude response characteristics of the system.

**Mathematical Expressions (Python):** The Mathematical Expression (Python) modules implement the calculation of mathematical functions of one, two, three or four variables. In this case is used to transform the voltage magnitude provided by the Two-Port Electrical Analyzer to power. The value is normalized for 1 ohm resistance value, so the expression just makes the square exponentiation.

**Linear to dBm Converter:** This module converts linear units into dBm units.

**Numerical Analyzer 2D:** The two dimension Numerical Analyzer module is an analyzer for numerical data. The module can display multiple data inputs on a two axis Cartesian plane plot and in this case is used to plot the different harmonic power levels at the system output.

Combined with previous modules it forms the main display of the simulation, plotting the power performance of the three main harmonics in the system. The next figure shows the assembly:

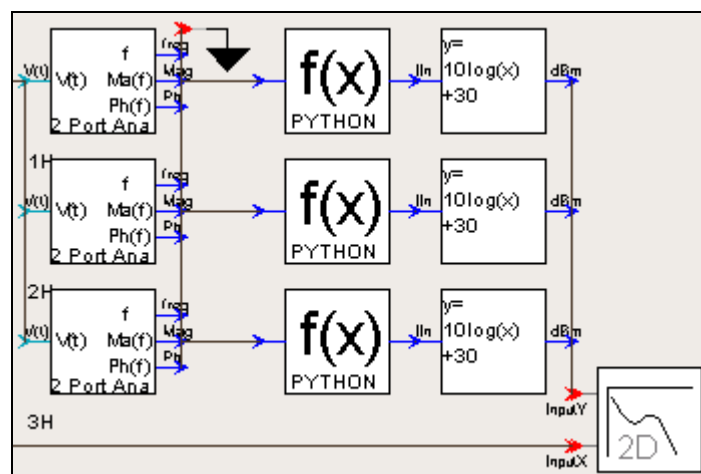

**Fig. 3.6** Plotting stage scheme

**Parameter Controller:** This module controls volatile parameters of the specified target. The selected parameters will be set to new values that are read from the input port or the input file. In this case the input is fed from next module, the ramp output.

**Ramp Output:** Produces a ramp waveform that increments (or decrements) in accordance with enhanced parameters which defines behavior of module during multiple runs, iterations or sweeps.

**Chop Data Blocks:** This module reads a sequence of input particles of any type, and writes a sequence of particles constructed from the input sequence.

These three blocks combined are used to vary different parameters, like length and modulating frequency from the fiber link to study the power variation on the system output harmonics. This module package is connected before the fiber link module.

In chapter 4 a typical IM-DD system simulation has been carried out to make a reasonable comparison versus AM-HG method. The system uses the same modules except for the transmitter polynomial linearizer because there is no need to perform an AM modulation. Also it does not obviously make any sense to place the harmonic generator at the receiver, because the system will not work with an intensity modulation. The amplifiers have been maintained to provide the same signal power treatment. Next figure shows the whole system configuration for an IM-DD system:

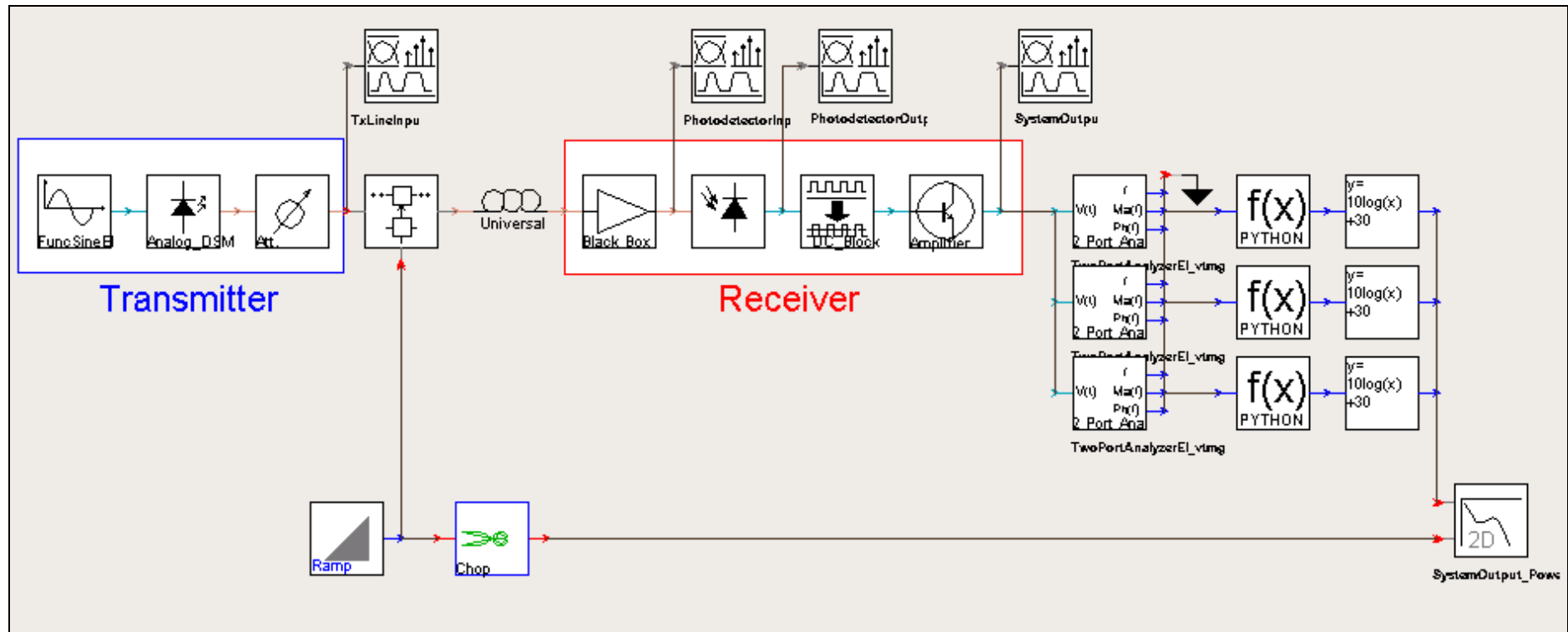

**Fig. 3.7** IM-DD simulation scheme

The IM-DD system does not need any calibration so some of the display modules used to calibrate the harmonic generator do not appear in the figure.

## CHAPTER 4. RESULTS

This chapter shows the results obtained for the AM-HG method and their comparisons.

First part of the chapter analyzes the optical and electrical spectrum in each stage of the system. The analysis of the spectrum behaviour includes the power level and the appearance of new frequency components.

The second part of the chapter studies the harmonics power level at the optical link output for different values of the chromatic dispersion index.

Considering the chromatic dispersion index definition (section 1.2.2) the harmonics power levels at the system output can be studied either varying the length of the fiber or the modulating frequency because the rest of parameters are physically fixed. In the performed simulation the variable parameter has been the optical fiber length.

A comparison with the IM-DD and the AM-SR methods has been done, to prove the advantages of the AM-HG. In order to do a fair comparison with other methods the extinction ratio parameter has been defined in the following lines, and fixed at the same value for all of them.

The extinction ratio (ER) is used to describe the efficiency with which the transmitted optical power is modulated over the fiber-optic transport. It is simply the relationship of the power used in transmitting a logic level "1" ( $P_1$ ) to the power used in transmitting a logic level "0" ( $P_0$ ). Extinction ratio can be defined as a linear ratio, as a power measurement, or as a percentage. In this case is defined as a power measurement in the next equation:

$$ER(dB) = 10 \log\left(\frac{P_1}{P_0}\right) \quad (4.1)$$

The definition of ER can be related to the modulation depth. However the ER is not equally defined by for AM or IM modulation, because of electric field is different in each case. The next expressions show the field definition and the ER equation for IM modulation:

$$\begin{aligned} E_{IM} &= \sqrt{P_0} \cdot \sqrt{1 + m_{IM} x(t)} \\ ER_{IM} &= 10 \log\left(\frac{1 + m_{IM}}{1 - m_{IM}}\right) \end{aligned} \quad (4.2)$$

On the other hand the AM modulation expressions are:

$$E_{AM} = \sqrt{P_0} \cdot (1 + m_{AM} x(t))$$

$$ER_{AM} = 10 \log \left( \frac{1 + m_{AM}}{1 - m_{AM}} \right)^2 = 20 \log \left( \frac{1 + m_{AM}}{1 - m_{AM}} \right) \quad (4.3)$$

To do a fair comparison between AM-HG and IM-DD methods the ER has been fixed to 10 dB. The modulation depth should be calculated for both methods, IM modulation should be  $m_{IM} = 0,81$  and  $m_{AM} = 0,52$  for the AM modulation. This will be the values applied as the modulating signal amplitude.

## 4.1. Spectrum behaviour

The spectrum gives information about the power distribution of the signal. This section analyzes the spectrum in each part of the optical link and explains the reasons for the design of each module. Firstly the spectrum of the AM-HG optical link will be analyzed sequentially.

### 4.1.1. AM-HG

The first module operating in the system is the electrical sine generator working as the modulating wave of the signal. The amplitude of this sine is adjusted at 0.81 V to provide a fixed extinction ratio of ER=10 dB. Note that with the values chosen for the laser diode and the predistorter circuit the sine amplitude defines a modulation depth of the same value.

The first spectrum image is taken from the transmission line input. It is in the next figure:

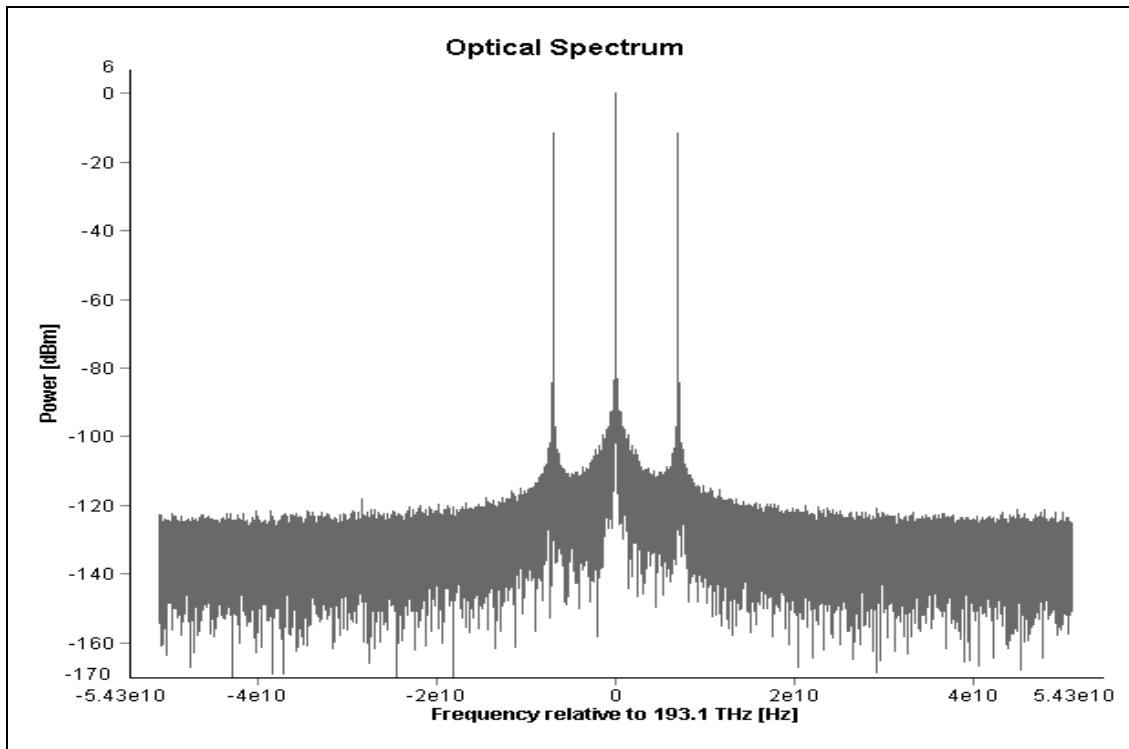

**Fig. 4.1** Transmission line input spectrum (AM-HG)

The figure shows a typical appearance of an amplitude modulation, with the fundamental component at the optical carrier frequency 193 THz and two harmonics separated from the fundamental a distance equal to the modulating wave frequency 7 GHz.

The power level of the fundamental is fixed to 0 dBm using the attenuator module and reducing 9 dB from the original signal. The power launched into the channel input is 1 mW, which is a more realistic value to avoid undesirable nonlinearities induced by the fiber. The power level of the sidebands in this modulation is -11,66dBm.

The optical wave passes through the fiber receiving the dispersion effect. The fiber dispersion parameter is fixed to a typical value of  $D = 16 \text{ ps/nm} \cdot \text{km}$ .

An optical amplifier placed before the photodetector powers up 10dBm the signal to mitigate the losses due to fiber dispersion. The amplifier also helps to introduce realism to simulation because of their frequently use.

In this point the power value of the fundamental is 9,42 dBm and the side bands are fixed to -2,25 dBm and the spectrum shape is the same as in figure (4.1). Now the electric amplifier gain can be calculated with the power level measurement of the fundamental harmonic at the photodetector input to calibrate the system. The gain applied by the electric amplifier using  $m_{AM} = 0,52$  should be:



$$G = \left( \frac{\gamma}{2 \cdot \mathfrak{R} \cdot 10^{\frac{P_0(\text{dBm})}{10}}} \right)^2 = \left( \frac{1}{2 \cdot 1(\frac{\text{A}}{\text{W}}) \cdot 10^{\frac{P_0(\text{dBm})}{10}}} \right)^2 = 3256 \Rightarrow G = 35\text{dB}$$

**(4.4)**

After the light detection the power levels are measured on the electrical spectrum. The following figure shows the electric spectrum at the photodetector output:

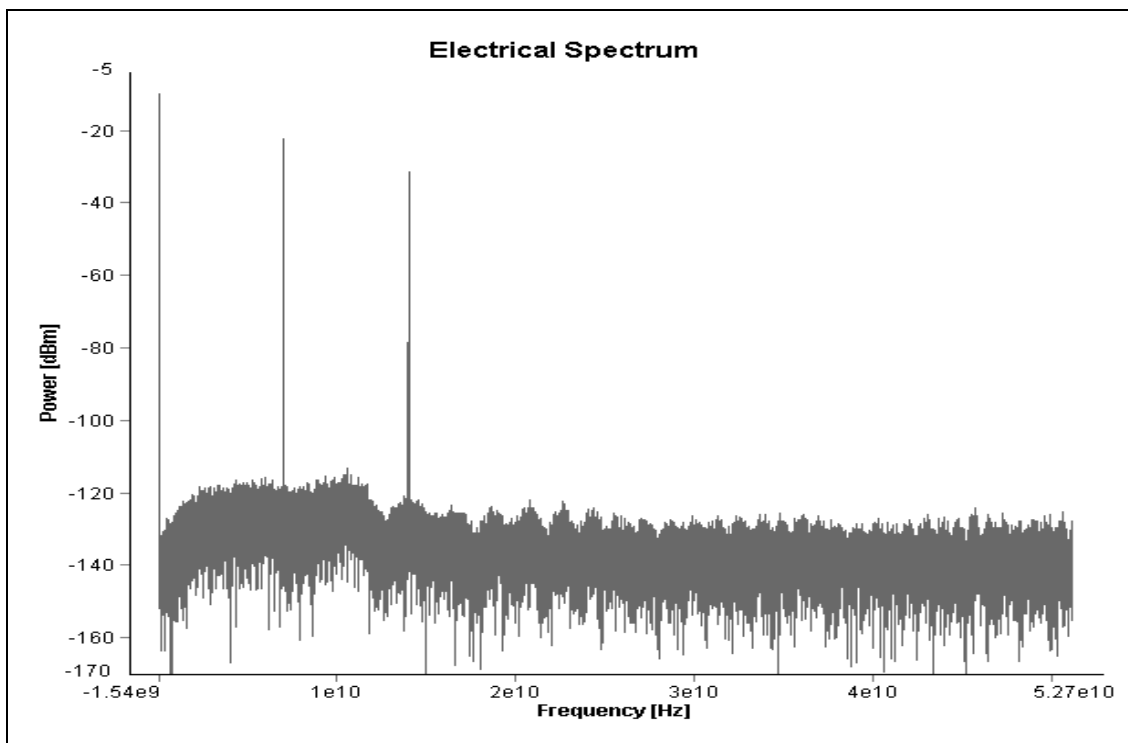

**Fig. 4.2** Photodetector output spectrum (AM-HG)

The power levels at the photodetector output are decreased due to the changes applied in the photodetecting process. The power levels are -22,21 dBm at the fundamental harmonic containing the information at 7 GHz and -31,53 dBm at the 2<sup>nd</sup> harmonic generating interference at 14 GHz.

In this particular AM-HG design is also required to place a continuous wave remover to implement the method.

At the harmonic generator input the continuous wave removing involves a small power loss, but using the electrical amplifier adjusted with a 35 dB gain calculated previously, the power levels of both harmonics are increased to

12,90 dBm and 3,59 dBm respectively and the 2<sup>nd</sup> harmonic power relative to the fundamental frequency becomes stable to 9,31 dB.

The next figure shows the electrical spectrum at the harmonic generator output. Arriving at this critical system stage the behaviour of the harmonics power level determines the efficiency of the AM-HG method. Remembering the chromatic dispersion index definition:

$$\chi = \frac{\pi}{c} \cdot D \cdot L \cdot \lambda^2 \cdot f^2 \quad (4.5)$$

The light velocity is a constant value. The dispersion is a fixed fiber parameter and the wavelength is also fixed to work in the 3<sup>rd</sup> window also due to fiber physical characteristics. Then the chromatic dispersion index variation will rely on the fiber length and the modulating frequency variations.

Therefore the results for 100 Km and 7 GHz apply for a different distance-frequency range, for example 1 Km and 70 GHz. For this reason the software is designed to perform a simulation from 0 to 100 Km, calculating 100 iterations with 1 Km intervals.

The previous spectrum figures do not receive a hard effect due to fiber parameters variation because the fiber attenuation and nonlinearities are reduced in the simulation in order to focus on the more relevant effects. The relative power between the fundamental harmonic and the 2<sup>nd</sup> order interferer harmonic remains stable.

The following figures show the electric spectrum at the harmonic generator output depending on the fiber length. The first figure shows the first iteration for 1 Km of fiber length:

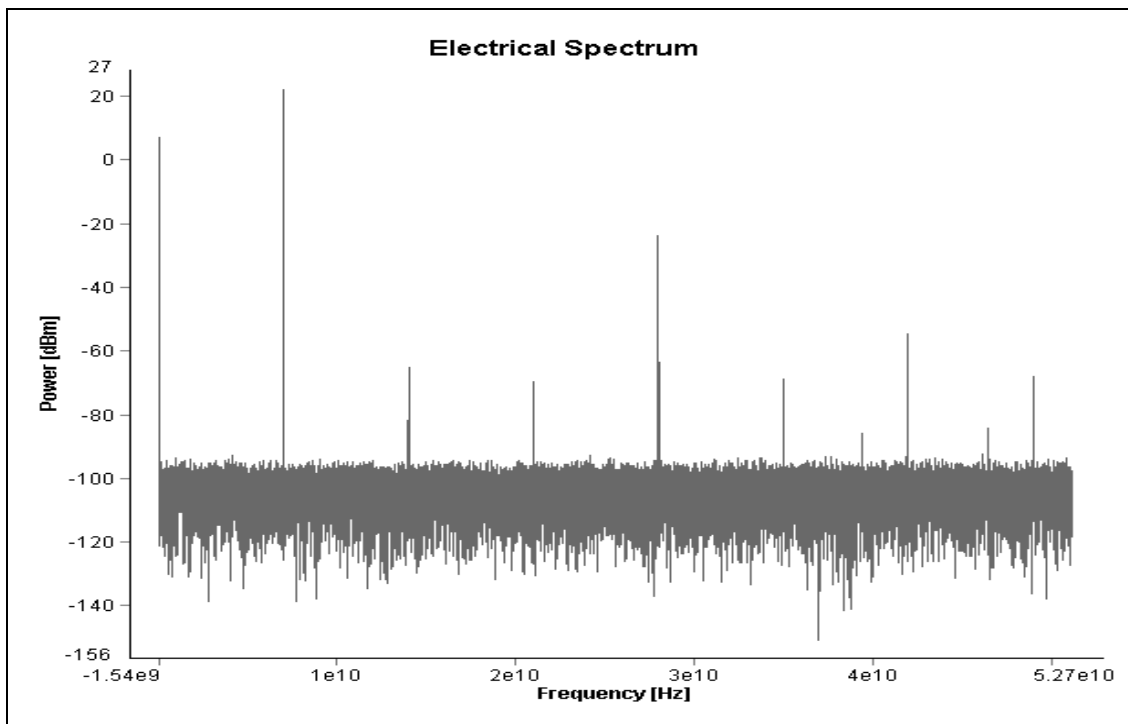

**Fig. 4.3** Harmonic generator output spectrum (1 Km)

In this case the electrical spectrum shows higher order harmonics at 7 GHz multiple frequencies, but their power level is always lower than -40 dBm for frequencies higher than the 4<sup>th</sup> harmonic at 28 GHz. These new harmonics have been generated by the harmonic generator. On the other hand the relation between the 2<sup>nd</sup> and 3<sup>rd</sup> harmonic, and the fundamental is considerably improved compared to the spectrum obtained before the harmonic generator, and their power level have decreased.

The 4<sup>th</sup> harmonic is over -30 dBm but we have to consider that the AM-HG system has been designed to reject the interference caused by the 2<sup>nd</sup> and the 3<sup>rd</sup> harmonics that have closer frequencies to the fundamental.

Figure (4.3) confirms the previous mathematical analysis in section (2.2) and follows the expected behaviour, but analyzing the spectrum for other length input values suggests taking the harmonic study further.

The figures show the harmonics power level suffers variation due to changes applied on the fiber length. Considering the results obtained is essential to analyze and plot the harmonic power levels at the output of the harmonic generator to characterize the system and determine the dependence on the chromatic dispersion index variation (section 4.2).

#### 4.1.2. IM-DD

In order to maintain the given extinction ratio the amplitude of the modulating signal is fixed to 0.52 V and there is no need to introduce a polynomial linearizer module to perform an intensity modulation.

The optical carrier frequency is fixed to 193 THz to work with the determined 1550 nm wavelength and the attenuator is placed before the fiber to fix the desired power, with a value of 9 dB as in the previous section, to match a 0 dB value for the fundamental harmonic at the transmission line input.

The next figure shows the optical spectrum at the fiber input:

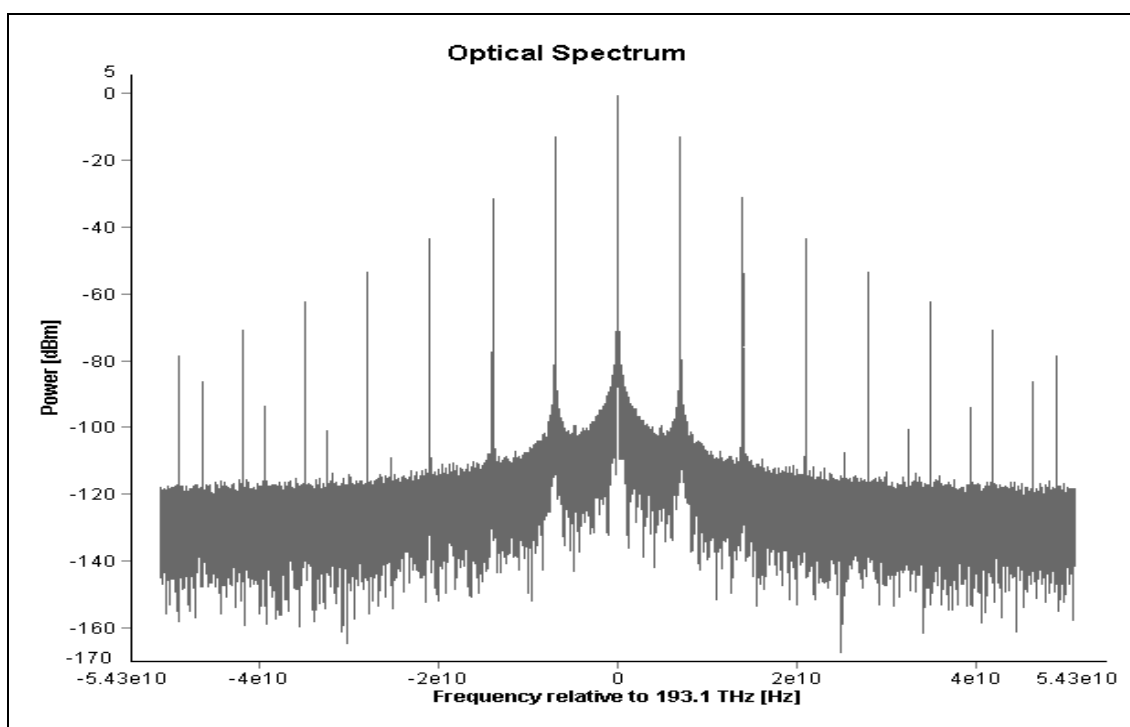
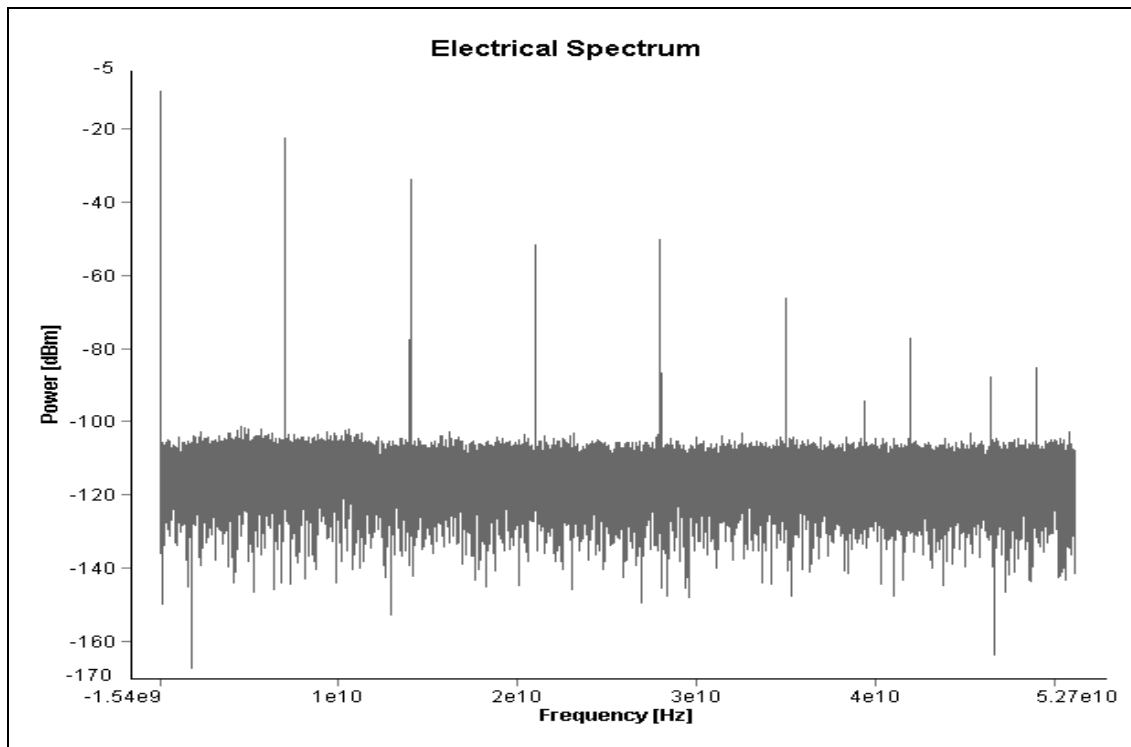

**Fig. 4.4** Transmission line input spectrum (IM-DD)

The spectrum of an intensity modulation generates harmonics at all the frequencies multiples of the modulating frequency and the power is distributed in an equitable way.

The spectrum at the photodetector input shows how the power levels are increased due to the optical amplifier effect fixed at 10dBm output power and the fundamental presents a power level of 9,54 dBm, the 2<sup>nd</sup> harmonic is increased to -3,16 dBm and the 3<sup>rd</sup> to -21,34 dBm.

The next figure shows the electrical spectrum at the photodetector output:



**Fig. 4.5** Photodetector output spectrum (IM-DD 100 Km)

After photodetection the power level values decrease as in the AM-HG. Comparing the electrical spectrum with the one obtained from the AM-HG figure (4.2), in this case new harmonics have appeared due to the power distribution nature of the IM modulation, and the power levels of these harmonics, including the fundamental, are similar to the AM-HG values.

The measured power levels for figure (4.6) of fundamental and 2<sup>nd</sup> harmonics are -22,43 dBm and -33,99 dBm respectively. The rest of harmonics are under -50 dBm values.

Finally the electrical spectrum at the output of the IM-DD system is directly the spectrum obtained after the continuous wave remover and the electric amplifier, because this method does not use any kind of linearization.

The amplification gain is fixed to 35 dB to maintain the comparison with AM-HG method.

The output system power levels also have a strong dependence on the fiber length. The next section will show the figures for different fiber lengths as compared with those obtained for the AM-HG system.

## 4.2. Harmonics power level

In this section the output power values of the key frequencies in the system have been plotted to compare the performance between the new presented AM-HG method, the classical IM-DD method and the AM-SR method [5].

The fundamental, the 2<sup>nd</sup> and the 3<sup>rd</sup> frequency components have been plotted depending on the fiber length variation to determine the behaviour of the system.

Theoretically to avoid nonlinearities the fundamental harmonic power level should be as high as possible and the interfering harmonics power level should be as low as possible. The most important indicator to compare different methods is the power difference between the fundamental and the harmonics provoking the interference, because of this the power levels are also defined relative to the fundamental harmonic.

### 4.2.1. AM-HG

The next figure shows the harmonics power level obtained for the AM-HG method in the setup of figure (3.1):

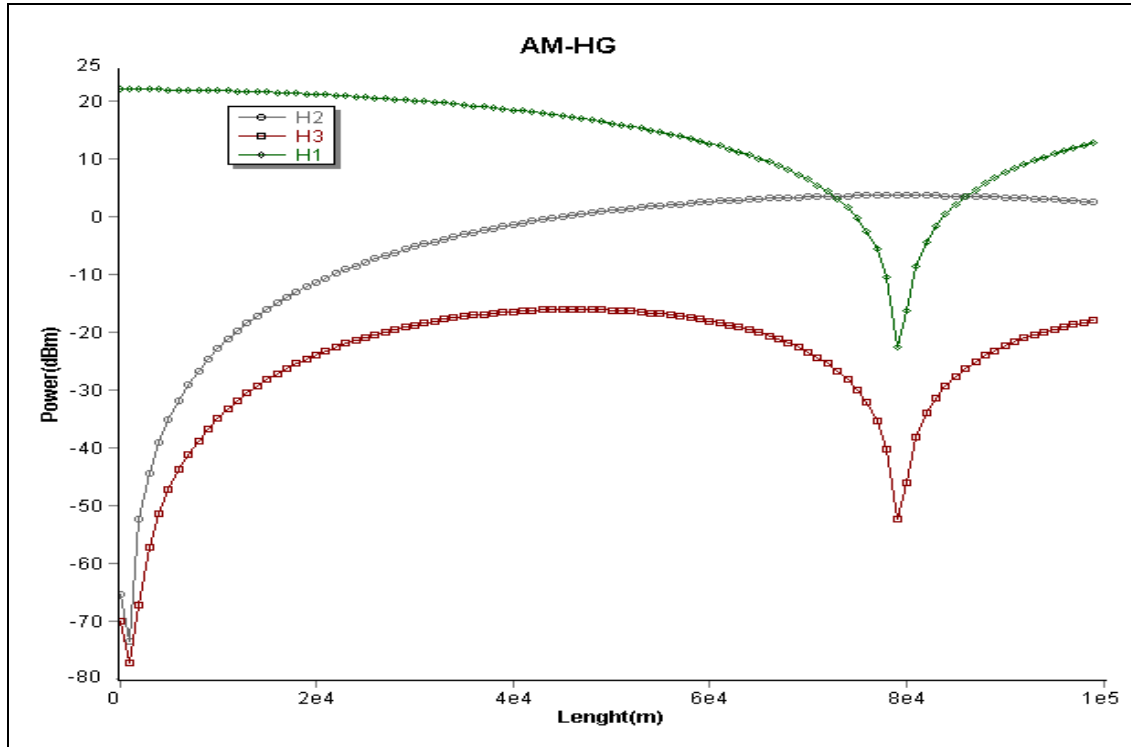

Fig. 4.6 AM-HG harmonics power level

The X axis of this figure can be interpreted in terms of the chromatic dispersion index since according to its definition (section 1.2.3, equation 1.7). The propagation of a signal of 7 GHz through a length  $L$  is equivalent from the viewpoint of dispersion to the propagation of a signal at frequency  $k \cdot 7GHz$  at  $L/k^2$ .

The power dependency with length is a key factor in the interfering harmonics. The best system operates with the highest “relative to fundamental harmonic power level” for a longer length or for a higher modulating frequency. This also means that it can work for a higher chromatic dispersion index.

In figure (4.6) the fundamental harmonic H1 is painted in green and decrease slowly to perform a power fall at 80 Km fiber length. The 2<sup>nd</sup> harmonic H2 is painted in grey and for no fiber length has its lowest power level with -73,32 dBm. The 2<sup>nd</sup> harmonic grows and maintains its maximum value until the 100 Km fiber length. The 3<sup>rd</sup> harmonic H3 is painted in purple, starts at a -78,08 dBm power level and suffers a power falls at 80km length just like H1.

The maximum power values are given and compared in the next section.

#### 4.2.2. Comparison with IM-DD

The next figure shows the power values for the IM-DD method simulated using the system in figure (3.7):

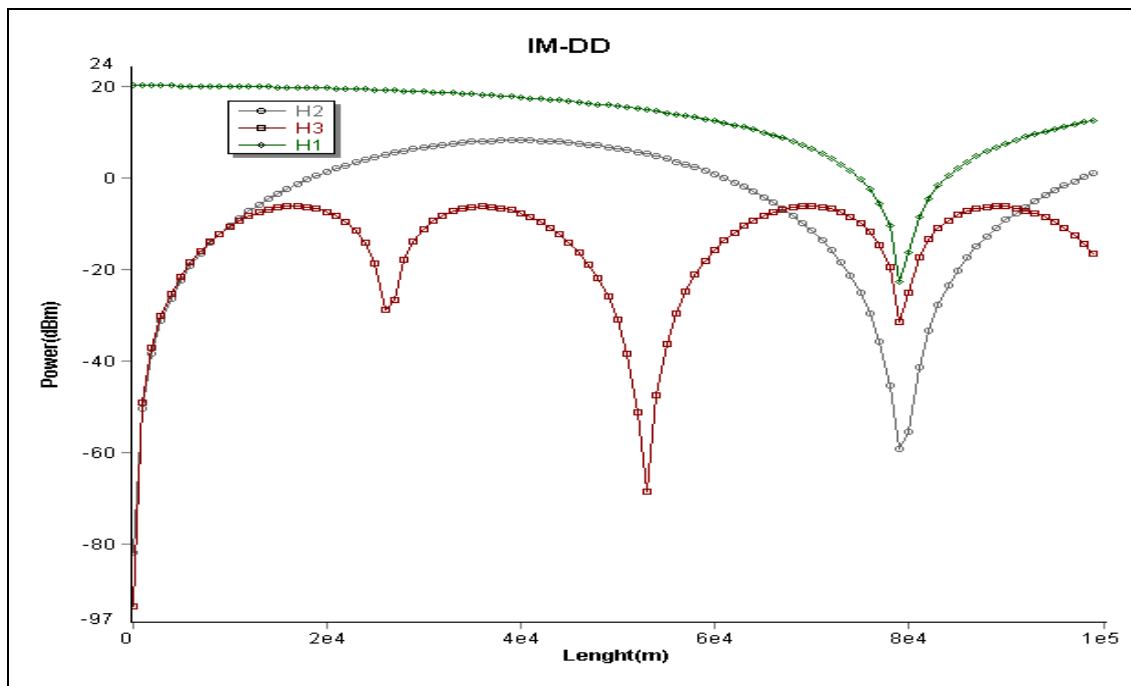

**Fig. 4.7** IM-DD harmonics power level

In this case the fundamental frequency component has a similar behaviour but the fundamental power level is lower than with the AM-HG. The 2<sup>nd</sup> harmonic has a higher maximum power level than AM-HG but performs a power fall at 80 Km. The 3<sup>rd</sup> harmonic has a higher maximum power level too, but performs several power falls at 26, 53 and 80 Km.

The next table compares the maximum power level of each harmonic and their relation with the fundamental H1:

**Table 4.1** AM-HG versus IM-DD comparison

Harmonic	AM-HG	IM-DD	AM-HG	IM-DD
	<i>Max. Power Level (dBm)</i>		<i>Power Relative to H1 (dB)</i>	
H1 (7 GHz)	22,21	20,36	-	-
H2 (14 GHz)	3,18	8,75	19,03	11,61
H3 (21 GHz)	-16,13	-5,89	38,34	26,25

The maximum power level values exposed in the previous table demonstrate that the AM-HG method gives a better power balance relative to H1. The 2<sup>nd</sup> harmonic improves that relative power level in 7,42 dB compared with IM-DD method, and the 3<sup>rd</sup> harmonic does the same with 12,09 dB difference.

On the table only the maximum power level values are shown but the power level behaviour should be considered depending on the fiber length variation, in figures (4.6) and (4.7).

In view of figures (4.6) and (4.7) it is seen how in the AM-HG method the 2<sup>nd</sup> harmonic provides a better relative power level up to a 64 Km fiber length, because the AM-HG method has not the same power fall at 80 Km as the IM-DD does.

The 3<sup>rd</sup> harmonic has a similar behaviour but in this case the AM-HG method always provides a better relative power level, except at punctual fiber lengths matching with the IM-DD power falls at 26 and 53 Km.

#### 4.2.3. Comparison with AM-SR

The AM-SR method has been selected to make a comparison because of its similarities with the AM-HG method. This method was published in *IEEE Photonics Technology Letters*.

AM-SR uses an AM modulation at the transmitter as the AM-HG but the electronic module implemented at the receiver has different characteristics. The function performed at this module is a square root (SR) and has been chosen



considering it is the inverse function of the square law characteristic performed at the photodetector. The next figure shows the AM-SR method block diagram:

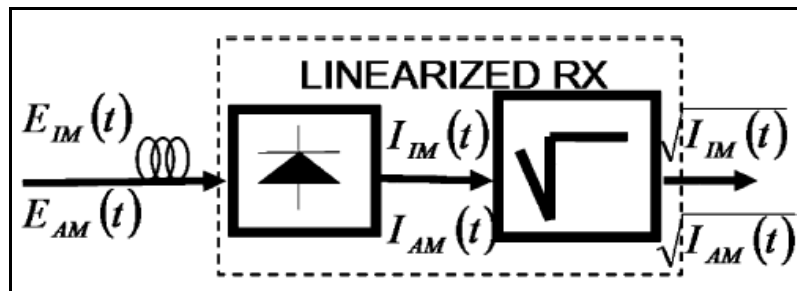

**Fig. 4.8** AM-SR receiver diagram

Considering that the AM-SR also uses AM modulation, the arriving current at the module input is the same obtained in the AM-HG mathematical analysis. The next equation shows the input photocurrent expression:

$$I_{AM}(t) = 1 + \frac{m_{AM}^2}{2} + 2 \cdot m_{AM} \cdot \cos(\chi) \cdot \cos(\omega t) + \frac{m_{AM}^2}{2} \cdot \cos(2\omega t) \quad (4.6)$$

The SR module performs the square root operation on the total arriving current expression. The resulting output equation is:

$$\begin{aligned} \sqrt{I_{AM}(t)} &\approx 1 + \frac{m_{AM}^2}{4} \cdot \sin^2(\chi) + m_{AM} \cdot \cos(\chi) \cos(\omega t) + \\ &+ \frac{m_{AM}^2}{4} \cdot \sin^2(\chi) \cos(\omega t) - \frac{m_{AM}^3}{8} \cdot \cos(\chi) \sin^2(\chi) \cos(3\omega t) \end{aligned} \quad (4.7)$$

The analytic results shown in figure (4.9) are very similar to AM-HG method because they are based on mathematic calculations.

It is worth noting though that as proposed, the SR module needs to perform the SR function on the total arriving current and that includes the CW level.

Thinking about the practical implementation of the linearizer as an RF circuit it will be very difficult that the module is able to treat the CW level.

In the letter it is argued that the Taylor expansion of  $\sqrt{1+x}$  could be used in the linearizer, but comparing with expression (4.6) for this polynomial to be

equivalent to the SR of input photocurrent the linearizer input should be equal to:

$$x = \frac{m_{AM}^2}{2} + 2 \cdot m_{AM} \cdot \cos(\chi) \cdot \cos(\omega t) + \frac{m_{AM}^2}{2} \cdot \cos(2\omega t) \quad (4.8)$$

So the linearizer input still includes a CW term depending on the modulation depth and not just the time varying part as in the HG method. This could induce measurement variations in the practical design results.

The values used in the AM-SR letter are exactly the same used in the AM-HG simulation, with an  $ER = 10dB$  and modulating frequency of 7 GHz.

The next figure shows the power values obtained in the AM-SR method simulation compared to an IM-DD method simulation. In this case the variable parameter has been the modulating frequency instead of the fiber length but the results are shown to correspond to equivalent values for a fixed  $\chi$ . It can be observed that the figure shape is close to AM-HG method figure (4.6). Note that the power values have been normalized to 0 dB to facilitate the comparison task:

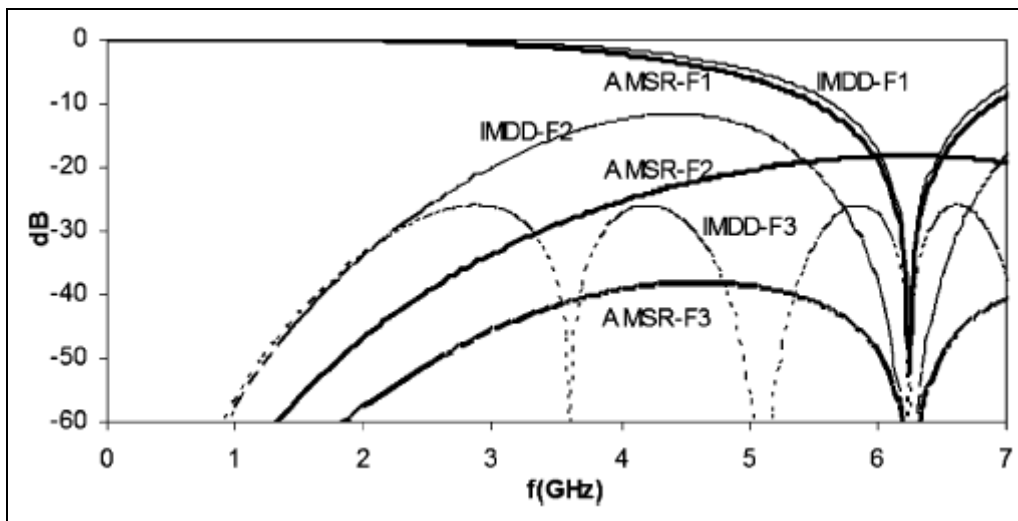

**Fig. 4.9** AM-SR harmonics power level

In the figure the harmonics can be differentiated by a label including the method and the harmonic order number (F1, F2, F3).

In the next table we can compare the harmonics power level values between AM-SR and AM-HG methods:

**Table 4.2** AM-HG versus AM-SR comparison

Harmonic	AM-HG	AM-SR	AM-HG	AM-SR
	<i>Max. Power Level (dBm)</i>		<i>Power Relative to H1 (dB)</i>	
H1 (7 GHz)	22,21	0	-	-
H2 (14 GHz)	3,18	-19	19,03	19
H3 (21 GHz)	-16,13	-41,6	38,34	41,6

The relative power level to H1 obtained for the AM-SR harmonics have the same order compared to AM-HG. The large difference is at least lower than 2,76 dB only for the 3<sup>rd</sup> harmonic.

## CONCLUSIONS

In this master thesis we have proposed a new linearization method to reduce the dispersion induced nonlinear distortion (DINLD) on the optical communication links. The analysis has been carried out through theoretical analysis of the fiber link equations.

The new linearization method consists on the combination of an amplitude modulation (AM) performed at the transmitter and an electronic module introduced at the receiver, after the photodetector, called harmonics generator (HG).

We have proven both analytically and through numerical simulation using software that the AM-HG system adjusted with an adequate gain calibration has given an improved performance of harmonics power level at the optical link output compared to a classical IM-DD system. It has been demonstrated that our system works without the CW level and the need to fix an exact input voltage has been identified.

A computer MATLAB code has been developed based on Fourier series and Taylor approximation, to obtain and apply the correct coefficient values at the harmonic generator module.

The AM-HG system has been simulated using the VPIphotonics software and the results obtained have been compared with a typical IM-DD system and other linearizing methods such as the AM-SR.

In the AM-HG versus IM-DD method comparison the relation between the fundamental harmonic and the 2<sup>nd</sup> harmonic power level has improved an order of 7 dB for optical links under a 64 Km fiber length. And the relation between the fundamental harmonic and the 3<sup>rd</sup> harmonic power level has improved an order of 12 dB for optical links along the full 100 Km fiber length.

The AM-HG system is also compared to the AM-SR system. In the comparison both methods give a similar performance on the optical link output power levels but the AM-SR method presents serious drawbacks on its practical implementation.

For this reason the electrical assembly of AM-SR system is expected to be more difficult than the AM-HG method, because is easier to implement physically a linearizer performing a polynomial function (AM-HG) than an ideal square root function (AM-SR).

## FUTURE LINES

Based on the works developed throughout this master thesis what follows is a list of possible future lines:

- Extend the software simulations including other damaging effects and see how vulnerable the AM-HG system is against ideality deviations as compared to conventional systems.
- Use in combination with linear equalizers in order to send data and evaluate BER and see BER improvements.
- Exploit the flexibility offered by the method of calculating coefficients here developed, to impose other conditions on the harmonics generator module output and to define harmonics generators that could serve other purposes and applications. As a specific goal within this future line it would be interesting to use the flexibility provided to force a power fall for the second harmonic at the same value where the fundamental has a zero to improve the performance done by linear equalizers.
- Work on techniques to design circuits that could physically implement the polynomials that could be calculated, both for the predistortion circuits as well as for the harmonics generator. They could be based on the nonlinear transfer curve of discrete Schottky diodes and should work in a broad bandwidth in order to support the high transmission velocities to be expected in fiber optic systems.

## BIBLIOGRAPHY

- [1] Chi H. Lee, *Microwave photonics*, Ed. Taylor & Francis group (2007).
- [2] España Boquera, M.C., *Comunicaciones ópticas*, Ediciones Díaz de Santos, Madrid (2005).
- [3] Cox, C.H., *Analog optical links : theory and practice*, Ed. New York Cambridge University (2004).
- [4] Freeman, R.L., *Fiber-optics systems for telecommunications*, Ed. New York Wiley-Interscience (2002).
- [5] Prat J., Santos M.C. and Omella M., "Square Root Module to Combat Dispersion-Induced Nonlinear Distortion in Radio-Over-Fiber Systems", *IEEE Photonics Technology Letters*, Vol. 18, N° 18, September 15 (2006).

## ANNEX

This annex includes the MATLAB code used to calculate the harmonics generator coefficients and should be useful to understand section (2.3) explaining software calculation.

```

clear

clc

syms k r1 r2 r3 r4 r5 r6 r7 r8 r9 r10 r11 r12 r13 r14 r15 r16 t wt tb

id=k*cos(t)*cos(wt)+k^2/4*cos(2*wt)

ig=id+r1*id^2+r2*id^3+r3*id^4+r4*id^5+r5*id^6+r6*id^7+r7*id^8+r8*id^9+r9*id^10+r10*id^11+r11*id^12+r12*id^13+r13*id^14+r14*id^15+...
    r15*id^16+r16*id^17;

clear functions

g1=sfourier3(ig,wt,1); % searching the 1rst harmonic content

gg1_1=eval(collect(taylor(g1,k,3),cos(t)))

g2=sfourier3(ig,wt,2); % searching the 2nd harmonic(H2) content

gg2_2=taylor(g2,k,3); % H2 searching the content multiplying k^2

clear functions

gg2_20= sfourier3(gg2_2,t,0) ; % H2 & k^2 searching the content without
cos(chi)
gg2_22= sfourier3(gg2_2,t,2) ; % H2 & k^2 searching the content with
cos(2*chi)

gg2_4=taylor(g2,k,5)-taylor(g2,k,3); % H2 searching the content multiplying k^4

clear functions
gg2_40= sfourier3(gg2_4,t,0) ; % H2 & k^4 searching the content without
cos(chi)
gg2_42= sfourier3(gg2_4,t,2) ; % H2 & k^4 searching the content with
cos(2*chi)
gg2_44= sfourier3(gg2_4,t,4) ; % H2 & k^4 searching the content with
cos(4*chi)

gg2_6=taylor(g2,k,7)-taylor(g2,k,5);

clear functions

```

```

gg2_60= sfourier3(gg2_6,t,0) ;
gg2_62= sfourier3(gg2_6,t,2) ;
gg2_64= sfourier3(gg2_6,t,4) ;
gg2_66= sfourier3(gg2_6,t,6) ;

gg2_8=taylor(g2,k,9)-taylor(g2,k,7);

clear functions
gg2_80= sfourier3(gg2_8,t,0) ;
gg2_82= sfourier3(gg2_8,t,2) ;
gg2_84= sfourier3(gg2_8,t,4) ;
gg2_86= sfourier3(gg2_8,t,6) ;
gg2_88= sfourier3(gg2_8,t,8) ;

gg2_10=taylor(g2,k,11)-taylor(g2,k,9);

clear functions
gg2_10_0= sfourier3(gg2_10,t,0) ;
gg2_10_2= sfourier3(gg2_10,t,2) ;
gg2_10_4= sfourier3(gg2_10,t,4) ;
gg2_10_6= sfourier3(gg2_10,t,6) ;
gg2_10_8= sfourier3(gg2_10,t,8) ;
gg2_10_10= sfourier3(gg2_10,t,10) ;

gg2_12=taylor(g2,k,13)-taylor(g2,k,11);

clear functions
gg2_12_0= sfourier3(gg2_12,t,0) ;
gg2_12_2= sfourier3(gg2_12,t,2) ;
gg2_12_4= sfourier3(gg2_12,t,4) ;
gg2_12_6= sfourier3(gg2_12,t,6) ;
gg2_12_8= sfourier3(gg2_12,t,8) ;
gg2_12_10= sfourier3(gg2_12,t,10) ;
gg2_12_12= sfourier3(gg2_12,t,12) ;

gg2_14=taylor(g2,k,15)-taylor(g2,k,13);

clear functions
gg2_14_0= sfourier3(gg2_14,t,0) ;
gg2_14_2= sfourier3(gg2_14,t,2) ;
gg2_14_4= sfourier3(gg2_14,t,4) ;
gg2_14_6= sfourier3(gg2_14,t,6) ;
gg2_14_8= sfourier3(gg2_14,t,8) ;
gg2_14_10= sfourier3(gg2_14,t,10) ;
gg2_14_12= sfourier3(gg2_14,t,12) ;
gg2_14_14= sfourier3(gg2_14,t,14) ;

g3=sfourier3(ig,wt,3);

gg3_3=taylor(g3,k,4);

```



*clear functions*

*gg3\_31= sfourier3(gg3\_3,t,1) ;*

*gg3\_33= sfourier3(gg3\_3,t,3) ;*

*gg3\_5=taylor(g3,k,6)-taylor(g3,k,4);*

*clear functions*

*gg3\_51= sfourier3(gg3\_5,t,1) ;*

*gg3\_53= sfourier3(gg3\_5,t,3) ;*

*gg3\_55= sfourier3(gg3\_5,t,5) ;*

*gg3\_7=taylor(g3,k,8)-taylor(g3,k,6);*

*clear functions*

*gg3\_71= sfourier3(gg3\_7,t,1) ;*

*gg3\_73= sfourier3(gg3\_7,t,3) ;*

*gg3\_75= sfourier3(gg3\_7,t,5) ;*

*gg3\_77= sfourier3(gg3\_7,t,7) ;*

*gg3\_9=taylor(g3,k,10)-taylor(g3,k,8);*

*clear functions*

*gg3\_91= sfourier3(gg3\_9,t,1) ;*

*gg3\_93= sfourier3(gg3\_9,t,3) ;*

*gg3\_95= sfourier3(gg3\_9,t,5) ;*

*gg3\_97= sfourier3(gg3\_9,t,7) ;*

*gg3\_99= sfourier3(gg3\_9,t,9) ;*

*gg3\_11=taylor(g3,k,12)-taylor(g3,k,10);*

*clear functions*

*gg3\_11\_1= sfourier3(gg3\_11,t,1) ;*

*gg3\_11\_3= sfourier3(gg3\_11,t,3) ;*

*gg3\_11\_5= sfourier3(gg3\_11,t,5) ;*

*gg3\_11\_7= sfourier3(gg3\_11,t,7) ;*

*gg3\_11\_9= sfourier3(gg3\_11,t,9) ;*

*gg3\_11\_11= sfourier3(gg3\_11,t,11) ;*

*gg3\_13=taylor(g3,k,15)-taylor(g3,k,13);*

*clear functions*

*gg3\_13\_1= sfourier3(gg3\_13,t,1) ;*

*gg3\_13\_3= sfourier3(gg3\_13,t,3) ;*

*gg3\_13\_5= sfourier3(gg3\_13,t,5) ;*

*gg3\_13\_7= sfourier3(gg3\_13,t,7) ;*

*gg3\_13\_9= sfourier3(gg3\_13,t,9) ;*

*gg3\_13\_11= sfourier3(gg3\_13,t,11) ;*

*gg3\_13\_13= sfourier3(gg3\_13,t,13) ;*

*clear functions*

```
gg3_11_1= sfourier3(gg3_11,t,1) ;
gg3_11_3= sfourier3(gg3_11,t,3) ;
gg3_11_5= sfourier3(gg3_11,t,5) ;
gg3_11_7= sfourier3(gg3_11,t,7) ;
gg3_11_9= sfourier3(gg3_11,t,9) ;
gg3_11_11= sfourier3(gg3_11,t,11) ;
```

```
gg3_15=taylor(g3,k,17)-taylor(g3,k,15);
```

*clear functions*

```
gg3_15_1= sfourier3(gg3_15,t,1) ;
gg3_15_3= sfourier3(gg3_15,t,3) ;
gg3_15_5= sfourier3(gg3_15,t,5) ;
gg3_15_7= sfourier3(gg3_15,t,7) ;
gg3_15_9= sfourier3(gg3_15,t,9) ;
gg3_15_11= sfourier3(gg3_15,t,11) ;
gg3_15_13= sfourier3(gg3_15,t,13) ;
gg3_15_15= sfourier3(gg3_15,t,15) ;
```

```
eq1=vpa(gg1_1,22)
```

```
eq2= gg2_20+gg2_22
```

```
eq3=gg3_31+gg3_33
```

```
eq4=gg2_40+gg2_42+gg2_44
```

```
eq5=gg3_51+gg3_53+gg3_55
```

```
eq6=gg2_60+gg2_62+gg2_64+gg2_66
```

```
eq7=gg3_71+gg3_73+gg3_75+gg3_77
```

```
eq8=gg2_80+gg2_82+gg2_84+gg2_86+gg2_88
```

```
eq9=gg3_91+gg3_93+gg3_95+gg3_97+gg3_99
```

```
eq10=gg2_10_0+gg2_10_2+gg2_10_4+gg2_10_6+gg2_10_8+gg2_10_10
```

```
eq11=gg3_11_1+gg3_11_3+gg3_11_5+gg3_11_7+gg3_11_9+gg3_11_11
```

```
eq12=gg2_12_0+gg2_12_2+gg2_12_4+gg2_12_6+gg2_12_8+gg2_12_10+gg2_12_12
```

```
eq13=gg3_13_1+gg3_13_3+gg3_13_5+gg3_13_7+gg3_13_9+gg3_13_11+gg3_13_13
```

```
eq14=gg2_14_0+gg2_14_2+gg2_14_4+gg2_14_6+gg2_14_8+gg2_14_10+gg2_14_12+gg2_14_14
```

```
eq15=gg3_15_1+gg3_15_3+gg3_15_5+gg3_15_7+gg3_15_9+gg3_15_11+gg3_15_13+gg3_15_15
```