



Martin Garage Door Owner Manual



THIS IS THE WORLD'S FINEST, SAFEST DOOR. HOWEVER, UNTRAINED OR NEGLIGENT INSTALLING ADJUSTING AND SERVICING CAN BE DANGEROUS. THE SPRINGS CAN CAUSE SERIOUS INJURY OR DEATH! IF UNSURE, CALL A TRAINED MARTIN DOOR DEALER.

The Latest Instruction Manuals and Supplements May be Viewed and Downloaded From our Web Site. www.martindoor.com

NOXIOUS FUMES

DO NOT completely weather seal this door! Vent according to local building codes.

CAUTION! Low levels of carbon monoxide in the garage and home can cause headaches and flu-like symptoms. Additional venting may be required to help reduce the health risks associated with combustible fuels and noxious fumes.

INSULATION

The insulation used in Martin Doors complies with all known building codes. It has been tested and approved by Omega Point Laboratories and meets the UBC-26-8 standard for smoke and flame spread. The insulation is removable and reusable, which helps the environment by reducing landfill waste!

DENT REPAIR (Steel Doors)

Martin regular and insulated door sections are rated among the most dent resistant in the world. They do not require insulation bonded to them for strength. Because of this unique construction it may not be necessary to replace a door section or a complete door to avoid the prolonged appearance of a damaged surface. For dent repair see "Dents" after step 28

WARRANTY

The Martin Warranty is to the original owner. Replacement part shipping and labor costs are not included. Spring coverage varies by model and application. To maintain rust protection, see "Oil" under maintenance. Note: With proper care and maintenance all Martin Doors are designed to last a lifetime. Contact your Martin Dealer for details on the full written warranty and limitations.

MAINTENANCE

Oil yearly all hinges, roller shafts and spring coils using a high quality 10/40 motor oil.

Do not allow parts to squeak! As needed use lightly oiled cloth to wipe galvanized parts to help retain clean galvanized look. In damp, wet, salty or caustic areas, door sections and galvanized parts may require painting to help prevent rust, etc.

Wax yearly Reverse Angle Shields or jambs where door seals while closing.

Wash away dirt, salt residue, etc. from door sections. Automobile type cleaners and waxes may improve the look and prolong the paint life on a neglected door.

Allow copper metal doors to age naturally and gracefully.

Clean the acrylic windows with a soft wet cloth. Remove scratches in the acrylic window pane with a quality plastic window cleaner.

DOOR OPENERS

Always keep the garage door in full view while using the electric opener.

Monthly check the automatic reverse function, following the manufacturer's electric opener instructions.

Martin Doors are designed to reduce risk of entrapment and injury to children and adults.

Roller Shields, Low Profile Hinges, Reverse Angle Shields, Inside Lift Cables, Rolled Steel Edges, etc., are all designed for added safety.

Remove all pull down ropes and disable any garage door locking mechanism.

The top door section may need a full length strut for center mounted openers. Side mounted openers may not require a strut on single size doors under 12'3" (3730) wide.

All measurements in parenthesis () are millimeters in this instruction manual.

MARTIN ADVANTAGE

THE FOLLOWING ITEMS ARE HELPFUL TO COMPLETE A SATISFACTORY MARTIN SECTIONAL GARAGE DOOR INSTALLATION

1. Hammer
2. Level
3. Hacksaw
4. Regular pliers
5. Two locking pliers with curved jaws
6. Measuring tape
7. 10/40 motor oil lubricant
8. Wax lubricant (paraffin, candle, etc.)
9. End wrench set for 7/16" [11], and 9/16" [14]
10. Cordless (impact) drill with 1/8" [3], 13/64" [5], 1/4" [6] bits plus 1/4" and 3/8" [6 and 10] masonry bits
11. Regular and phillips screwdriver plus 5/16" [8] nut driver
12. Two 1/2" X 14" [13 X 356] high carbon steel, spring winding tubes (Larger sizes available)
13. Punched angle track hanger: 8' X 1-1/4" X 1-1/4" [2440 X 32 X 32]
14. "C" clamps for Reverse Angle Shield to jambs, helps make installation easier.
15. Socket wrench set for 7/16" [11], and 9/16" [14] with 3" [76] extension

Not shown:

- Rope 5' to 6' (1520 to 1830), Step ladder and saw horses
7.25" (184) power hand saw with TENRYU # PRF-18548BW saw blade may be used to cut down door.

NOTE: Bolts, lock nuts and lag screws for fastening the punched angle are furnished with the door hardware fasteners.

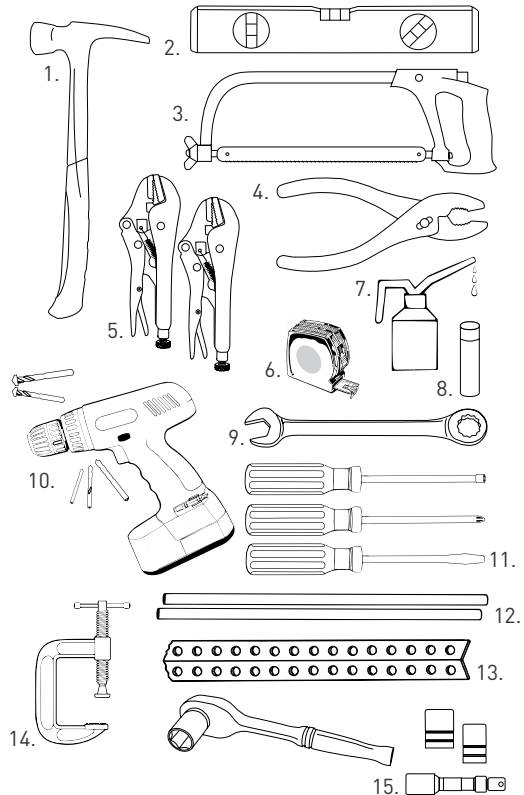

HARDWARE

1. 1/4" X 1/2" SHORT NECK CARRIAGE BOLT
2. 3/8" X 1" SHORT NECK CARRIAGE BOLT
3. 3/8" X 1-1/2" BOLT 9/16 (14) HEX HEAD
4. 3/8" LOCK NUT 9/16" (14) HEX HEAD
5. 1/4" LOCK NUT 7/16" (11) HEX HEAD
6. #6 LOCK NUT 5/16" (8) HEX HEAD
7. 5/16" X 2" LAG SCREW, 7/16 (11) HEX HEAD (FOR WOOD JAMBS OR PLASTIC ANCHORS)
8. 3/8 X 2" PLASTIC ANCHOR USE WITH 5/16" X 2" LAG SCREW (CONCRETE, BRICK, STONE JAMBS DRILL 3/8" HOLE, 2 1/2" (64) DEEP)
9. CLEVIS AND COTTER PIN
10. 5/16" X 3/4" OR 3/8" X 1" SELF TAPPING SCREW 7/16 (11) HEX HEAD (STEEL JAMBS)
11. 3/8" X 1" RED HEAD SET SCREW
12. 1/4" X 5/8" THREAD FORMING SCREW 7/16 (11) HEX HEAD
13. 1/4" X 3/4" SELF DRILLING SCREW 7/16 (11) HEX HEAD
14. ROPE STRAP
15. WASHER FOR SLIDE BOLT LOCK AND HANDLE



1.

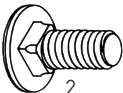

2.

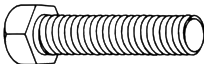

3.



4.



5.



6.



7.

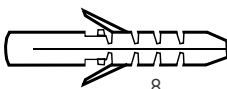

8.

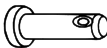

9.

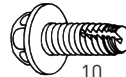

10.



11.



12.

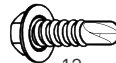

13.



14.

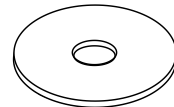

15.

DOOR SECTION PLACEMENT EXAMPLES

NOTE: Example of section placement. Section sizes vary by model. Most door model heights to 20' (6100) are available in 3" (76) increments. 10', 12', 14', 16', 18', 20' (3050, 3660, 4270, 4870, 5480, 6100) high doors use 24" (610) high sections only.

See www.martindoor.com or contact a Martin Dealer for more details.

GATEWAY

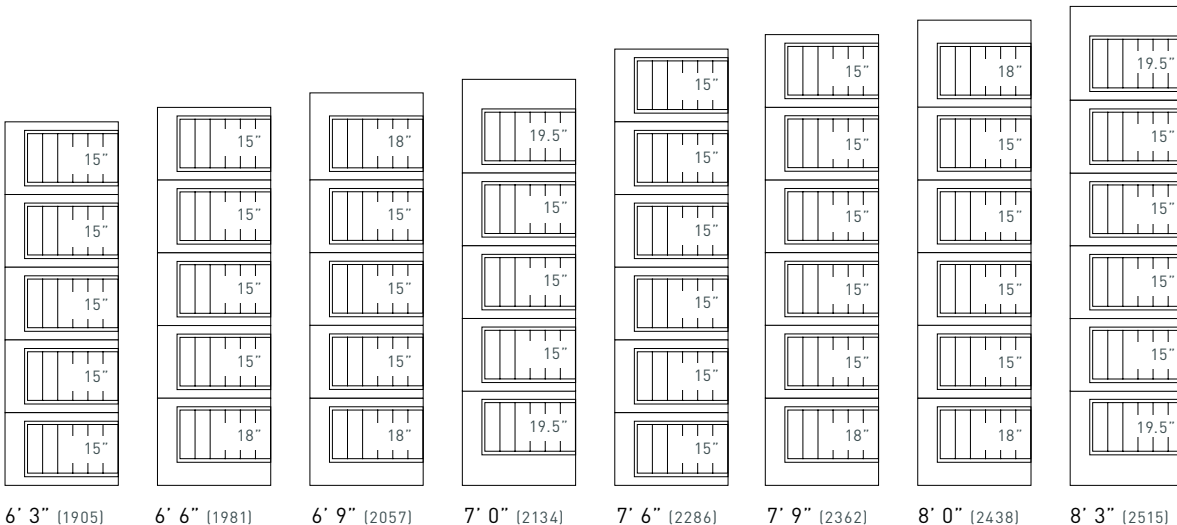

DOOR SECTION PLACEMENT EXAMPLES

MARTIN STANDARD

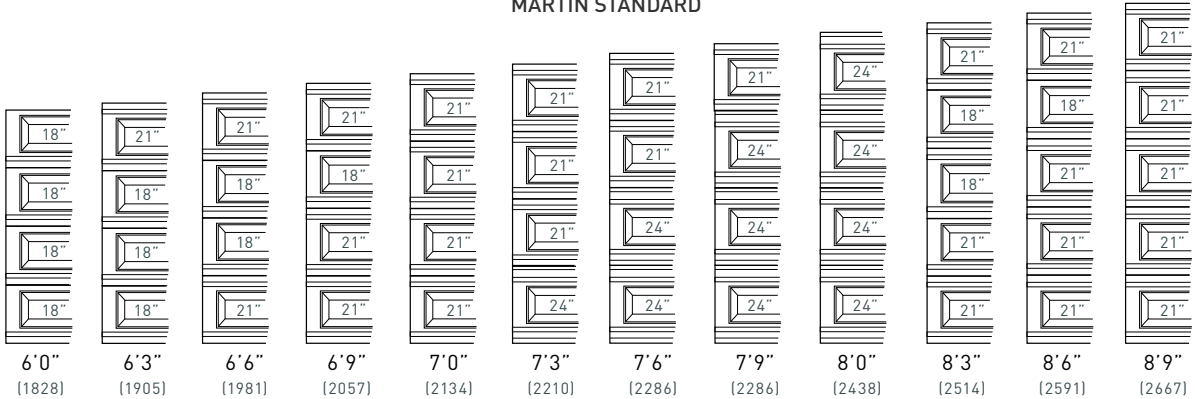

CORNERSTONE

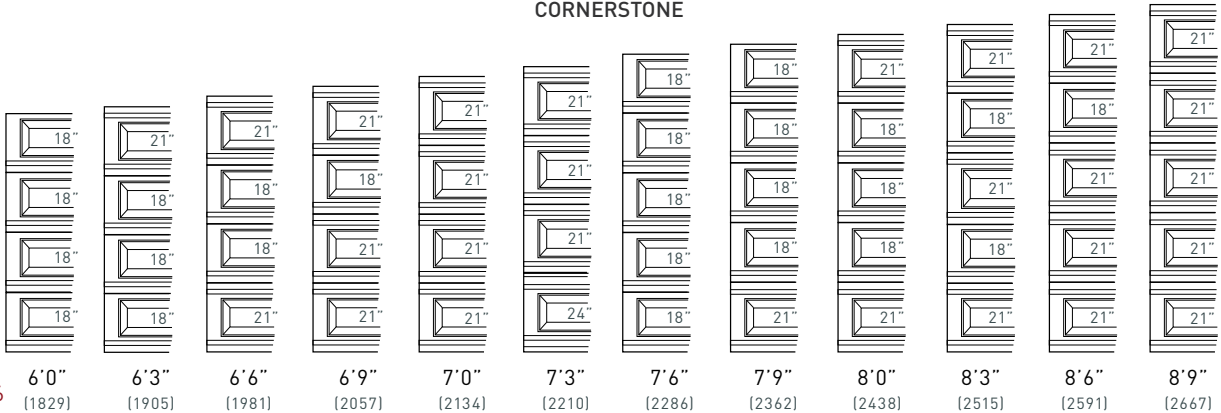

DOOR SECTION PLACEMENT EXAMPLES

ALUMINUM DOOR SECTION PLACEMENT CHART EXAMPLE

18" = {460}

21" = {530}

24" = {610}

PINNACLE

NOTE: 6'6" high and above have 24" high top window section.

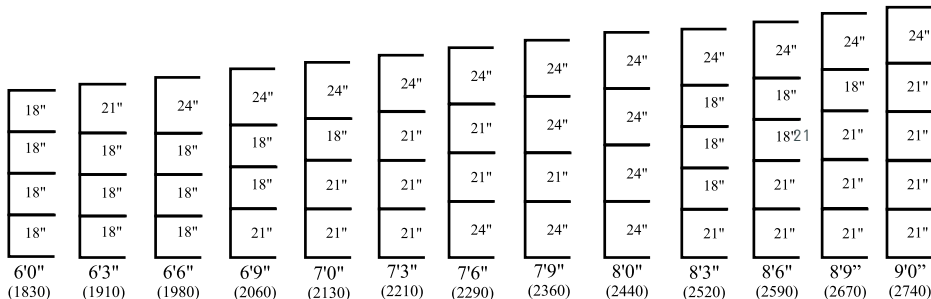

ATHENA

All Athena Doors have a bottom section and top section. All panel heights are the same.

DOOR OPENING INFORMATION

FIGURE 1 (Recommended for Reverse Angle mount)

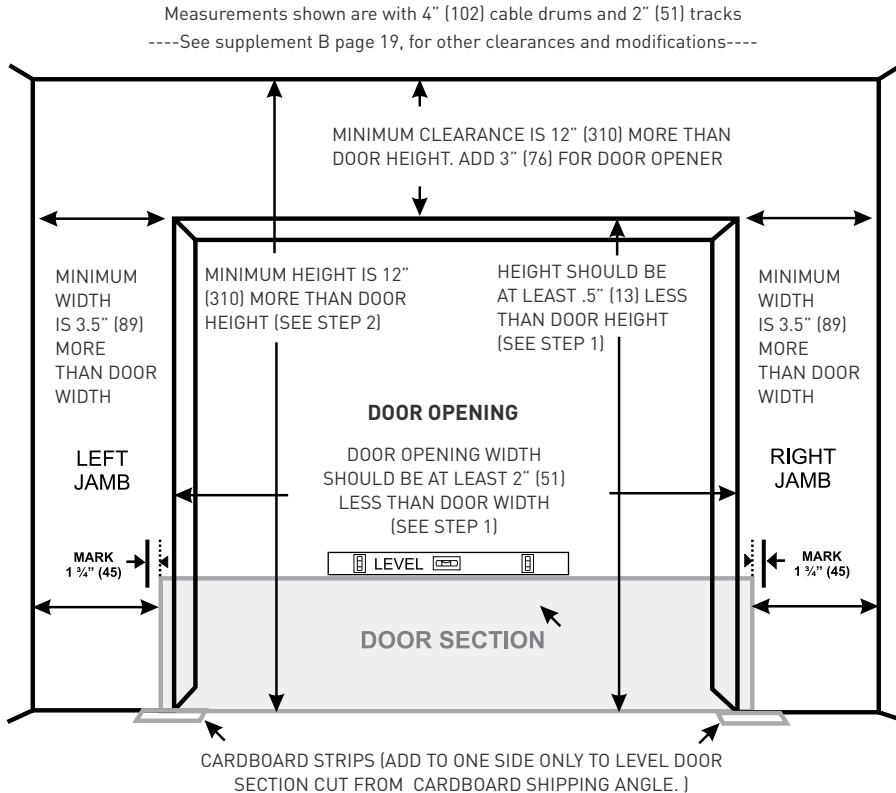

INSTALLATION INSTRUCTIONS

THESE INSTRUCTIONS ARE INTENDED FOR PROFESSIONAL GARAGE DOOR INSTALLERS. READ THROUGH THE COMPLETE INSTRUCTION MANUAL AND APPLICABLE SUPPLEMENTAL INSTRUCTIONS ENCLOSED BEFORE BEGINNING.

FIGURE 2 (Bracket mount)

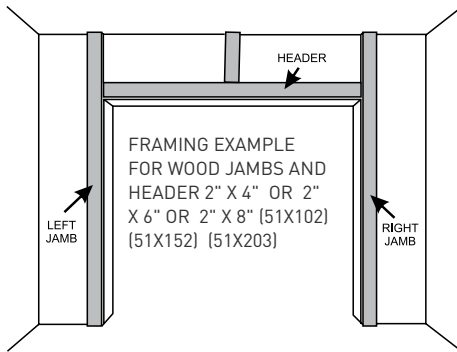

NOTE: Builders, Architects, and Design Engineers should consider forces transmitted by the door to the building structure as a result of wind load and/or door weight. This consideration includes the door opening structure and the supporting structures for the door track assembly.

Contact Martin Door Mfg. for additional or specific load requirements.

STEP 1

Study the "Door Opening Information" measurements. Be aware of the following common obstructions: Closet, fireplace, lighting, heat ducts, etc. The jambs and the header should form a flush inside surface. Note: Standard Martin sectional doors are manufactured 2" (51) over common USA door opening widths and 1/2" (13) over common USA door opening heights. Example: A 16' x 7' (4880 x 2130) door is manufactured 16' 2" wide by 7' 1/2" (4930 x 2150) high. The extra expense for special door molding (doorstop) for some types of installations may not be required. (See Figure 1 and 2)

Reverse Angle Mount: Upgraded models such as Cornerstone include the Martin "Reverse Angle Shield" track to jamb mounting system. For ideal Reverse Angle installations, opening should be finished with all surfaces flush. (See Figure 1)

Bracket Mount: Basic models such as Standard and some Cornerstone include the "Bracket" track to jamb mounting system. The door opening for "Bracket Mount" should be prepared with wood jambs and header. See Figure 2.

Place two cardboard strips on the floor on each side of the door opening. Place the #1 door sections behind the door opening, setting it on the two cardboard strips. Add cardboard strips to one side, if necessary, to make the door section level. Strips are cut from cardboard shipping angle. Mark both jambs 1 3/4" (45) wider than each side of the level door section. The two marks are important to correctly begin fastening the Reverse Angle Shields to the door jambs in STEP 8. (See Figures 1 and 9)

Note: Most headers are level (Most floors are not level).

FIGURE 3

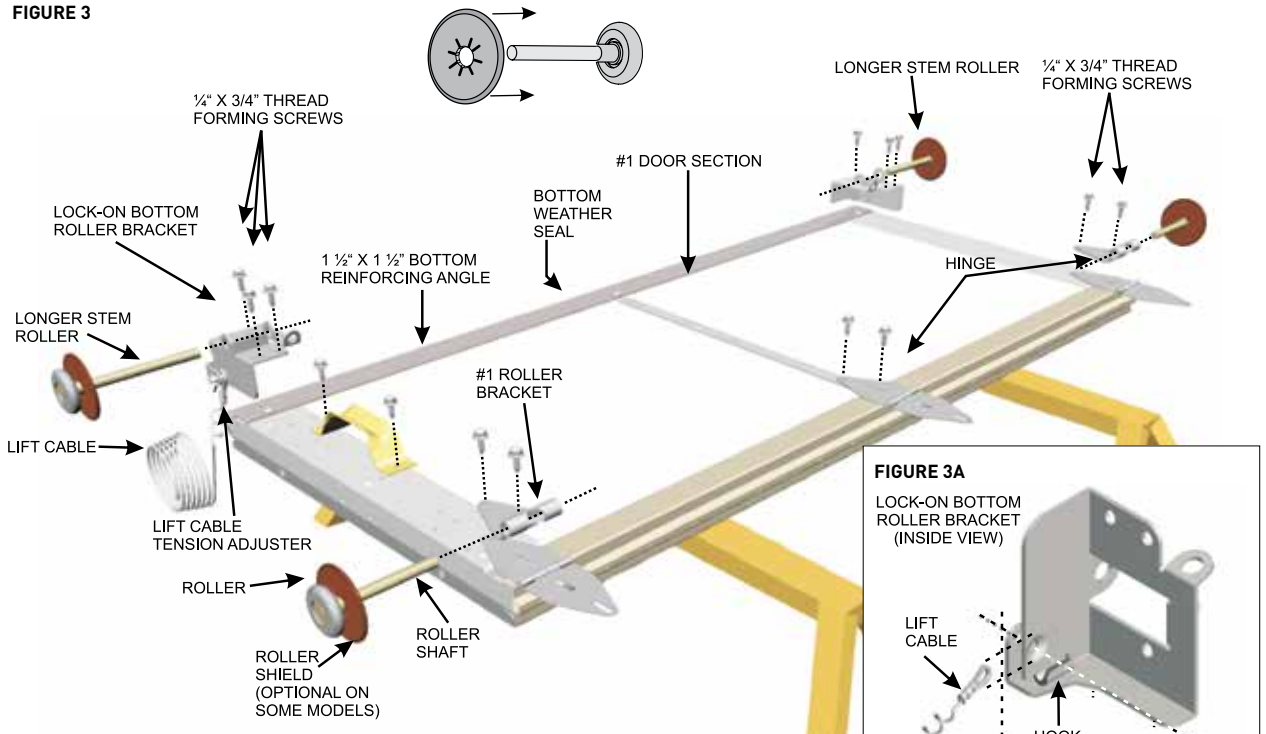

Note: Some models include "longer stem" bottom rollers which add strength during earthquakes and high winds. All hinges fasten face down into grooves provided on a aluminum doors.

FIGURE 3A

LOCK-ON BOTTOM ROLLER BRACKET (INSIDE VIEW)

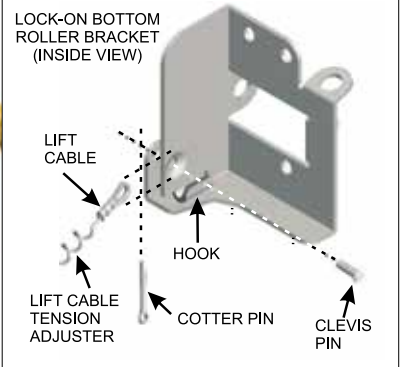

STEP 2-5

STEP 2

INSTALLATION OF THIS SECTIONAL DOOR CAN BE DANGEROUS. CALL A TRAINED MARTIN DOOR DEALER

The required clearance above a door furnished with 4" (102) diameter cable drums is 12" (310) when using 2" (51) track or 17" (430) when using the optional 3" (76) track. See supplement "B", for clearance and modifications information if the required clearance needs to be changed. More clearance is required for bigger diameter cable drums.

Martin Low Clearance Track Kits are only available for 2" (51)Track and includes safer inside lift cables.

STEP 3

Door Section Placement. Refer to previous pages for correct placement of door sections. If the door has a Spring Latch Lock, the #2 door section is the best location for the outside T-lock handle.

Bottom Reinforcing Angle and Weather Seal. If not installed, fasten the bottom reinforcing angle to the bottom inside edge of the #1 section with 1/4" X 5/8" thread forming screws. Fasten along the bottom of the door section, on each stile location. Slide the loop style bottom weather seal into the reinforcing angle. Trim weather seal to proper length without stretching. The bottom reinforcing angle may act as a full length step plate on non-insulated doors.

STEP 4

If not already assembled, attach the lift cables to the right and left lock-on bottom roller brackets with clevis and cotter pins. The Lift Cable Tension Adjuster helps equalize the right and left lift cables even if the door hits an object causing side twist. (See Figure 3A)

STEP 5

Fasten the right and left lock-on bottom roller brackets tight against the bottom corners of the #1 door section. Make sure the hook on the inside of the lock-on bottom roller bracket is hooked under the end stile. The thread forming screws go through the lock-on bottom roller bracket, the bottom reinforcing angle, the inside return of the door section, and fasten tight into the 1/8" holes in the stile. (See Figure 3) Do not remove the plastic fasteners that are pressed into the center stile hinge holes on steel/copper doors. The 1/4" x 5/8" thread forming screws easily penetrate and fasten through the thin plastic heads.

Fasten the bottom half of the hinges and the #1 roller brackets to the top of the #1 door section. Insert rollers. (See Figure 3)

BRACKET MOUNT

For doors equipped with Reverse Angle Shields, skip this page

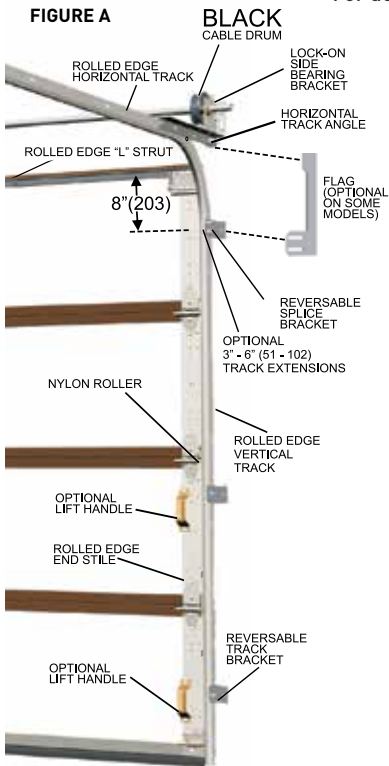

FIGURE A
BRACKET MOUNT COMPLETED ASSEMBLY



FIGURE B

2. Set #1 door section in door opening (must be level). Hold in place with 2 - 16d nails. (See Figure B)
3. Assemble and stack remaining sections. Hold in place with 16d nails. (See Figure B)
4. Assemble track brackets and splice brackets to vertical tracks. Place vertical tracks around rollers and fasten to jambs with 2" lag screws. The top of the vertical tracks are set 8" (203) lower than top of level door. (See Figure A) NOTE: Cut off required amount from bottom of vertical tracks for low clearance and shorter height doors.
5. Attach lock-on side bearing bracket to the horizontal track angle. (See Figure A)
6. Hold back of horizontal track level with rope or ladder. Fasten horizontal tracks to splice brackets or flags. Fasten lock-on side bearing brackets to jamb. (Also Figures 14A, 14B)
7. Assemble left (red) cable drum, side spring anchor bracket, spring, coupler, and center bearing bracket to left half of torsion tube. Insert torsion tube in left lock-on-side bearing bracket, and then fasten center bearing bracket straight and level to wood pad. (See Steps 20, 22, 23)
8. Insert right half of torsion tube in right (black) cable drum and right lock-on side bearing bracket. Fasten coupler to right half of torsion tube as shown. (See Steps 20, 22, 23)
9. Attach end of lift cables to each cable drum. Hold torsion tube in place with locking pliers. Wind springs approx. 8 turns for 7' (2130) high doors and 9 turns for 8' (2440) high doors. Fasten spring set screws with wrench. (See Steps 22, 23)
10. Install center lock or opener.
11. Oil and wax where needed.

STEP 6

FIGURE 5

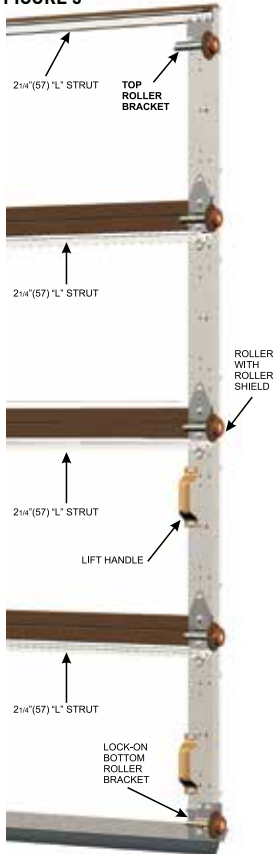
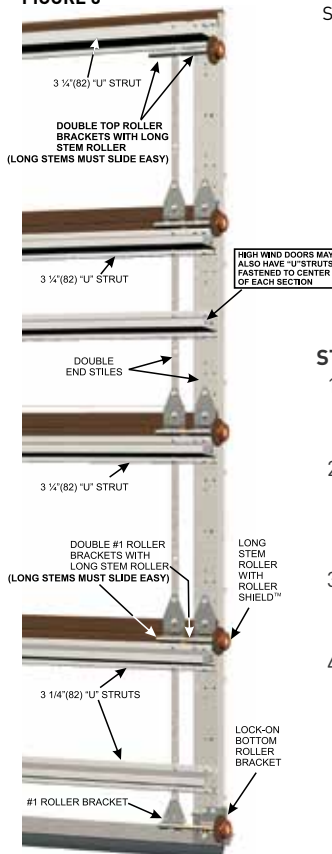

FIGURE 6



SEE STEP 18 FOR TOP ROLLER BRACKET AND TOP STRUT INSTALLATION

FIGURE 5A

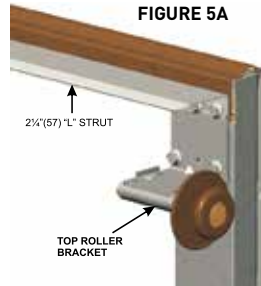
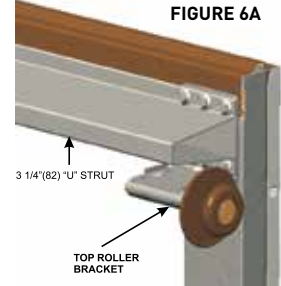

FIGURE 6A



STEP 6: MARTIN STRUTS FOR STRENGTH AND WIND LOAD

1. One 2 1/4" (57) "L" Strut, for the top door section, is furnished for all residential steel/copper doors 12'3" (3730) to 16'2" (4930) wide. (See Figure 5A)
2. Four or Five 2 1/4" (57) "L" Struts are furnished for steel/copper door sections, except series II, on residential doors 16'3" (4950) to 18'2" (5540) wide. (See Figure 5) Series II is furnished with one top strut. (See Figure 5A)
3. Four or Five 3 1/4" (82) "U" Struts are furnished for the door sections on residential doors 18'3" (5560) to 20'2" (6150) wide (See Figures 6, 6A).
4. Eight to ten 3 1/4" (82) "U" Struts are furnished for the door sections on residential doors 20'3" (6170) to 24'2" (7370) wide. This width door usually includes double end stiles, double roller brackets with hinges, and long stem rollers. (See Figures 6, 6A--Also see supplement D,E,F)

SPECIFIED HIGH WIND(HURRICANE) DOORS MAY RECEIVE MORE STRUTS. (See STEP 7 and Figure 7)

STEP 7-8

STEP 7

High Wind Modifications

Many Martin Door models are designed for wind gust speeds in excess of 90 mph (145 km). Standard models may have lower wind ratings, fewer struts and lighter gauge hardware than upgraded models. Doors specified for high wind ratings or a given PSF (pounds per square foot), will include struts and hardware necessary to meet the requirement. See Figure 7 for strut placement examples. (See Wind Gust Speed Reference Chart)

STEP 8

REVERSE ANGLE SHIELDS (RA Shields)

For safety, strength and appearance many models are furnished with RA Shields. They fasten solid to most flush surfaces including wood, concrete, brick, block, plaster, drywall, tile, stone, steel, etc. Each fastener adds strength to all fasteners in the assembly.

BENEFITS:

- Fastens to most surfaces.
- Shields children's arms, hands, and fingers from moving door, track brackets and lift cables.
- Shields wind, rain, snow from entering the garage.
- Provides steel surface for door to close against. (no swelling or shrinking)
- Provides professional fit for doors made 2" (51) wider.
- Door molding (stops) may not be required. This provides more door opening width.
- Wood jambs and header are not required. This could provide 2" (51) more garage depth.
- Reverse Angle Shields (RA Shields) provide double Strength to the track assembly.

WIND GUST SPEED REFERENCE CHART

PSF	12.5	15.5	18.5	22	26	30	34.5	39
MPH	90	100	110	120	130	140	150	160
KPH	145	161	177	193	209	225	241	257

DOOR STRUTS

FIGURE 7 - COMMERCIAL DOOR STRUT PLACEMENT (STEEL DOORS)

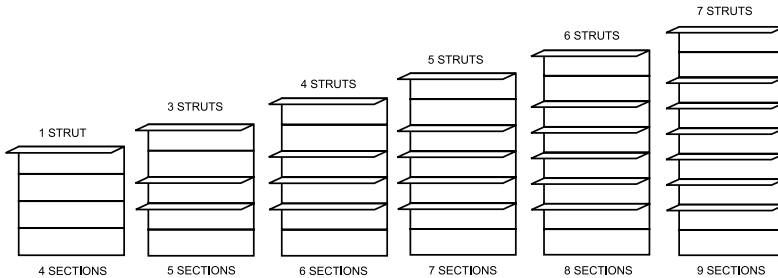

12' 3" (3730) TO 16' 2" (4930) WIDE DOORS INCLUDE 2-1/4" (57) "L" STRUTS AS SHOWN.

NOTE: ONE 2 1/4" (57) STRUT ONLY IS FURNISHED FOR ALL TOP DOOR SECTIONS OF A SERIES II SKINNED DOOR, 12' 3" (3730) TO 16' 2" (4930) WIDE. (SEE FIGURE 5B)

16' 3" (4950) TO 18' 2" (5540) WIDE DOORS INCLUDE 2 1/4" (57) "L" STRUTS AS SHOWN. 18' 3" (5560) TO 20' 2" (6150) WIDE DOORS INCLUDE 3 1/4" (82) "U" STRUTS AS SHOWN. NOTE: ONE 2 1/4" (57) "L" STRUT ONLY IS FURNISHED FOR ALL TOP DOOR SECTIONS OF SERIES II SKINNED DOORS, 16' 3" (4950) TO 18' 2" (5540) WIDE. (SEE FIGURES 5,5B,6,6B)

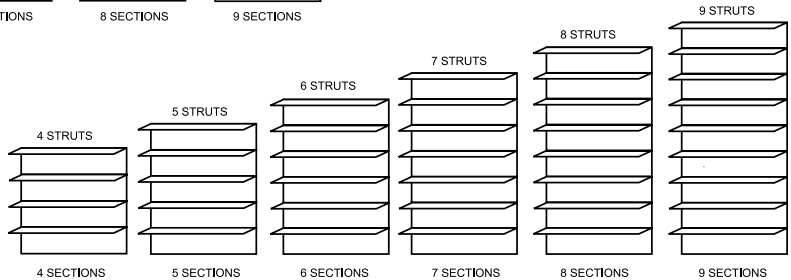

HURRICANE WIND LOAD TYPE DOORS MAY REQUIRE ONE EXTRA STRUT AT BOTTOM OF DOOR DIRECTLY ABOVE THE BOTTOM BRACKET. PILOT HOLES TO BE DRILLED AT JOB SITE. IF DOOR HAS UNACCEPTABLE SAG PLACE SHIMS UNDER "U" STRUTS.

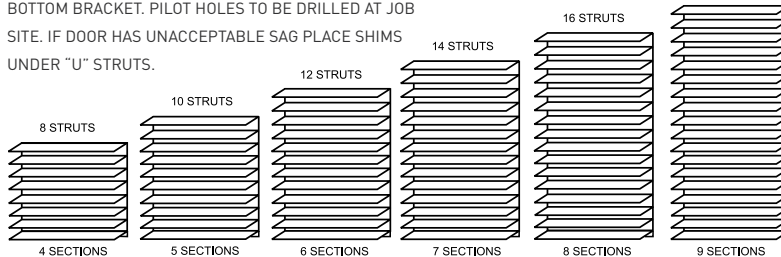

20' 3" (6170) TO 24' 2" (7370) WIDE DOORS INCLUDE TWO 3 1/4" (82) STRUTS FOR EACH DOOR SECTION AS SHOWN BELOW. (SEE FIGURE 6) STRUTS MUST BE FASTENED OVER EACH ROLLER BRACKET WITH 3 THREAD FORMING SCREWS AND THEN BOLTED TOGETHER IN HOLES PROVIDED.

FIGURE 9

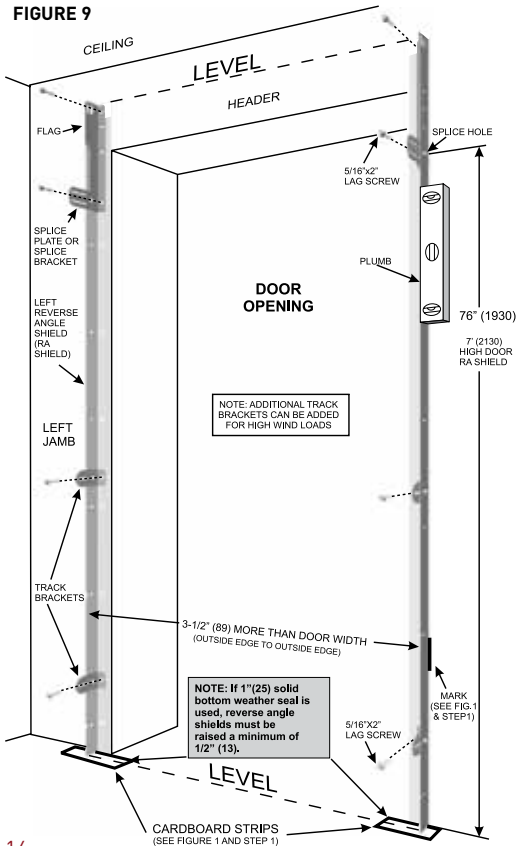
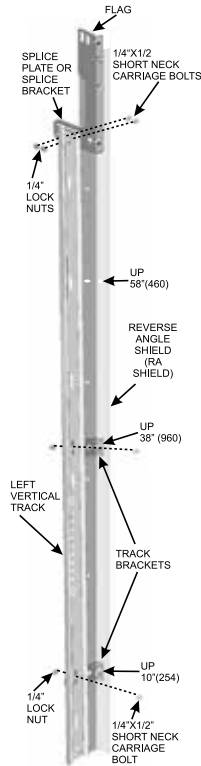

FIGURE 10



NOTE: Some models provide Bracket mount which require other installation modifications.

STANDARD VERTICAL TRACK LENGTHS		STANDARD DOOR HEIGHTS
76" [1930]	=	7' 2130
88" [2240]	=	8' 2440
100" [2540]	=	9' [2740]
112" [2850]	=	10' [3050]
136" [3450]	=	12' [3660]
160" [4060]	=	14' [4270]
184" [4670]	=	16' [4880]
208" [5280]	=	18' [5490]

STEP 8 CONTINUED

STEP 8 CONTINUED

The following measurements are important to verify:

Vertical Track Lengths are the same as RA Shields, up to the splice hole.

If the door is less than standard height, be sure to check all measurements. If measurements are not correct, cut off the bottom of the vertical tracks and the RA Shields the amount the door furnished is less than the standard door height. Door height reductions are in 3" (76) increments.

Standard Bottom Weather Seal on door should fit floors 1" (25) out of level. Optional 2 1/2" (64) Bottom Weather Seal is available from the factory for floors up to 2 1/2" (64) out of level.

FASTEN RA SHIELDS TO THE JAMBS

1. Make sure the marks made on the left and right jambs during step 1 are visible. The marks were made about 1 3/4" (45) more than each door section side width. These new marks are the outside of the RA Shields which total 3 1/2" (89) more than door width. [See Figure 9]
2. Set the RA Shields on the same cardboard strips, placed on the floor, behind the jambs, to level the door section in STEP 1.
3. Use "C" clamps or nails to hold the RA Shields in place until they are fastened in a plumb position, in line with the marks. [See Figure 9]

Note: "C" clamps are easy to use on any type jamb.

4. Drill holes for fasteners at each bracket location. Make sure the fastener holes are the same measurement up from the level cardboard strips placed to level the door section in STEP 1. [See Figure 9]
 - Wood Jambs: Drill 1/8" (3) holes then fasten with 5/16" x 2" lag screws.
 - Steel Jambs: Drill 5/16" (8) hole. Fasten with 3/8" x 1" self tapping screws - or weld.
 - Steel or Alum. Jambs: Drill 5/16" (8) hole. Fasten with 3/8" x 1" self tapping screws.
 - Block type Jambs (Hollow, etc.): Buy the correct fasteners from a local supplier.
 - Concrete, Brick or Stone type Jambs: Drill 3/8" (10) holes 2 1/2" (64) deep for 2" (51) plastic anchors. Push anchors in holes and fasten with 5/16" x 2" lag screws.
5. Measure the width from RA Shield to RA Shield at the top and at the bottom. Verify that each measurement is about 3 1/2" (89) wider than the door width. Check to make sure all fasteners in RA Shields are tight and strong. [See Figure 9]
6. Fasten the left vertical track to the left splice plate and splice brackets with 1/4" x 1/2" short neck carriage bolts and 1/4" lock nuts. Finger tighten only until STEP 15. [See Figure 10]

STEP 9-11

FIGURE 11

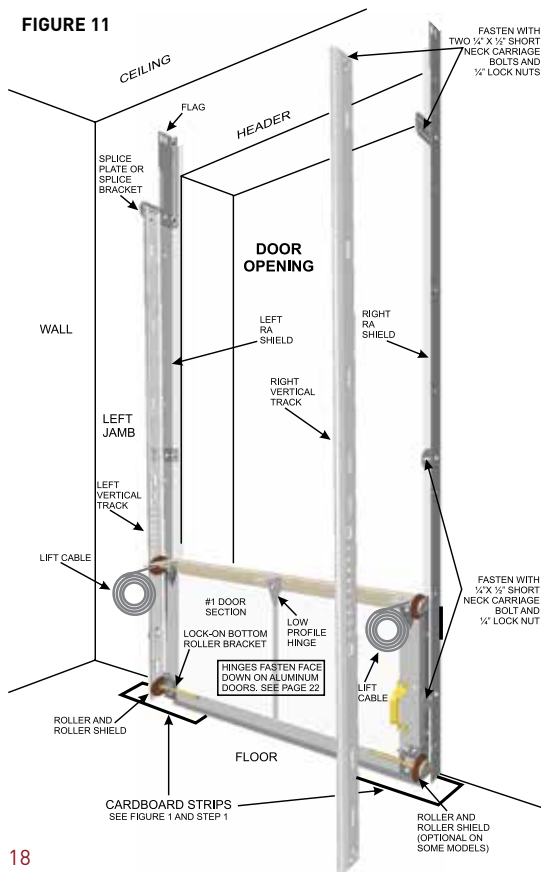

STEP 8 CONTINUED

Set the assembled #1 door section on the strips of cardboard, placed on the floor in STEP 1. The two rollers on the left side of the #1 door section fit into the left vertical track first, before setting the #1 door section on the cardboard strips. Center between the RA Shields. (See Figure 11)

Fit the right vertical track over the two rollers on the right side and fasten with 1/4" x 1/2" short neck carriage bolts and 1/4" lock nuts. Finger tighten only until STEP 15 (See Figure 11)

STEP 9

Fasten the optional T-Lock handle, spring latch lock system, if provided, to the #2 door section, following the instructions in the lock package.

STEP 10

Fasten the bottom half of the center hinges only to the top of the #2 door section. Do not fasten the #2 roller brackets--fasten in STEP 12.

STEP 11

Set the #2 door section on top of the #1 door section, at an angle first. (See Figure 12A) Hold the #2 door section in place with locking pliers clamped to the rolled edge of each vertical track. (See Figures 12B) Fasten the top half of the #1 door section hinges to the bottom of the #2 door section. Hold door sections close together while fastening to keep the door section gap to a minimum. (See Figure 12B)

STEP 12-16

STEP 12

Fasten the #2 roller brackets with hinges to each top corner of the #2 door section. Fit the rollers in the vertical tracks before fastening. Roller brackets #1, #2, #3, etc., cause the vertical track to incline. This allows the door to lift away from the jambs as it opens. (See Figure 12B,12D) Hinges are fastened face down on aluminum doors.

STEP 13

Set the #3 door section on top of the #2 door section following STEPS 10, 11, 12.

STEP 14

Decide optional window placement. Residential windows are normally a top section.

STEP 15

Set the remaining door sections in place following STEPS 10, 11, and 12. Hold each door section in place with locking pliers as explained in STEP 11. (See Figure 12C)

Extra heavy doors #5, #6, #7, #8 roller brackets should be fastened with 4 thread forming screws. The extra two holes are provided in the stiles, under the steel back skin on series II doors. (See Figure 12E)

Note: Thread forming screws can penetrate steel back skin without drilling.

Push the vertical tracks forward until the door sections lightly touch the RA Shields then tighten all bolts and nuts. The top of the vertical tracks should be about 8" (203) to 8 ½" (216) down from the top of the door. Each side should measure the same.

STEP 16

If extra clearance is available above the door, it may be desirable to fasten an optional vertical track extension kit to the top of the vertical tracks. The door will lift higher when open. Extensions available are 3"(76) and 6"(152). The springs, lift cables and cable drums are made to allow up to 6"(152) of extra vertical track without additional modifications. (See Figure 13C) (N/A for some models.)

FIGURE 12A

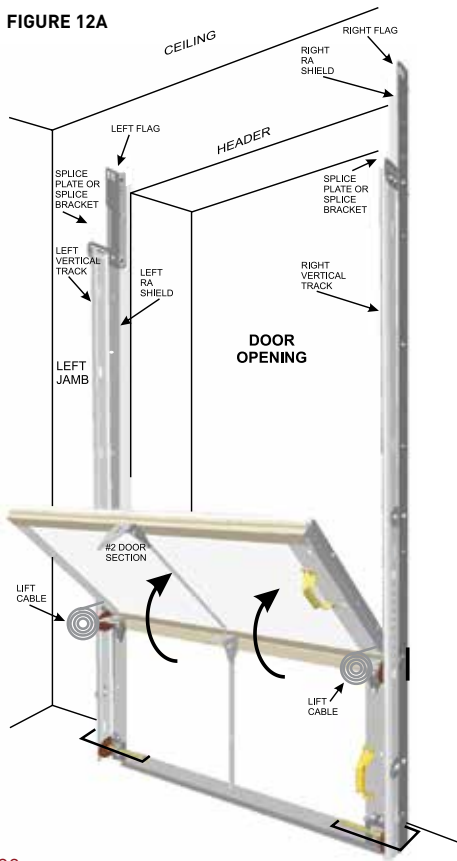

FIGURE 12B

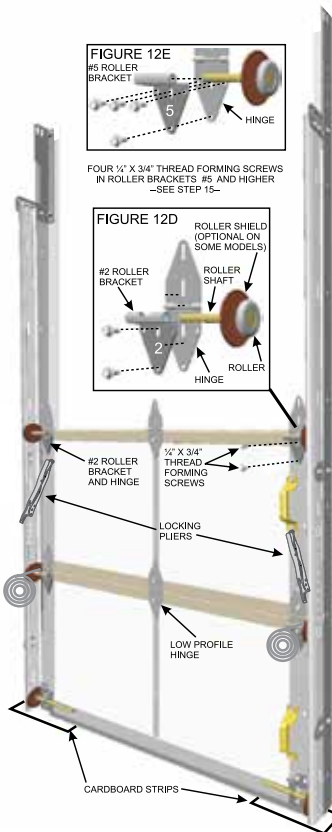
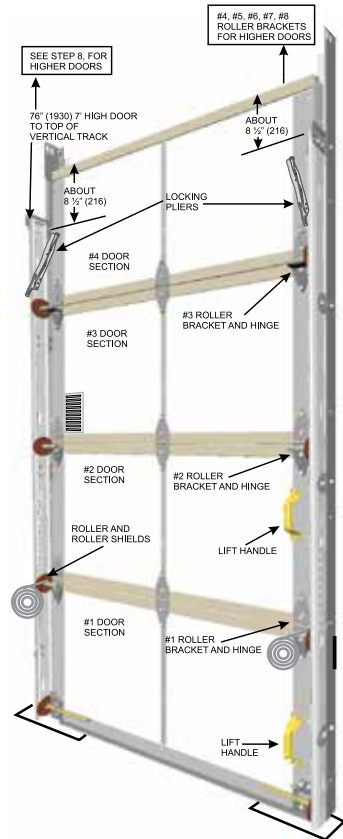

FIGURE 12C



STEP 17

FIGURE 13

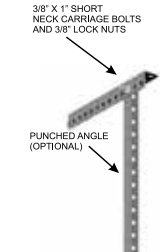

FIGURE 13B

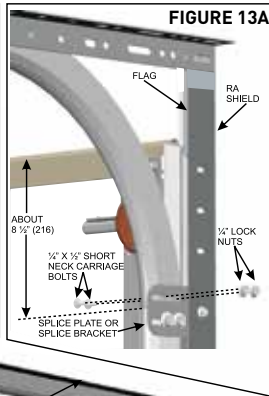
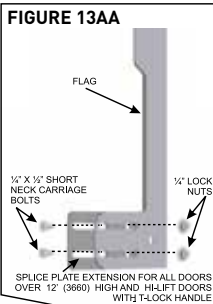
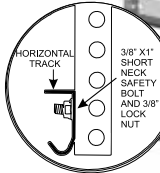
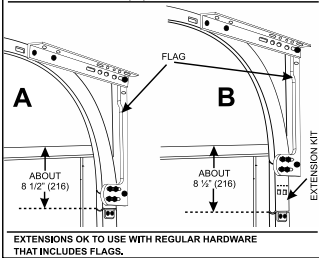

FIGURE 13C

(ALSO SEE STEP 16)

A OPTIONAL 3" (76) VERTICAL TRACK EXTENSION KIT

B OPTIONAL 6" (152) VERTICAL TRACK EXTENSION KIT
 *Can be cut to 3" (76)



EXTENSIONS OK TO USE WITH REGULAR HARDWARE THAT INCLUDES FLAGS.

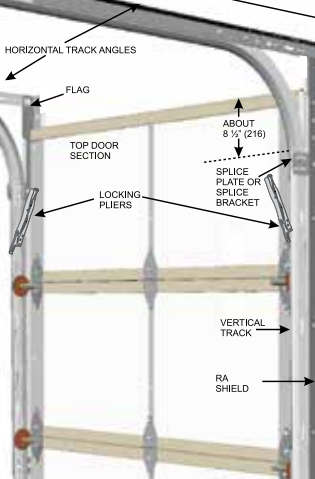

STEP 17

The top of the vertical tracks should be about 8" [203] to 8-1/2" [216] down from the top of the closed door. (See Figures 13,13A) Each side should measure the same.

If working alone, use a ladder or use a rope tied to a rafter to hold up the back of the horizontal track.

Fasten the curved front end of the left and right horizontal tracks to the splice plates or splice brackets with 1/4" X 1/2" short neck carriage bolts and 1/4" lock nuts. (See Figures 13, and 13A) See Figure 13AA for splice plate extension for doors over 12' (3660) high.

Fasten the front of the horizontal track angle to the top of the flag or reverse bracket shields with a 3/8" X 1" short neck carriage bolt and a 3/8" lock nut. (See Figures 14A,14B)

Level the horizontal tracks and set them parallel and square back from the door. Fasten the horizontal tracks at the back, using optional punched angle track hangers with 3/8" X 1" short neck carriage bolts and 3/8" lock nuts. One of the bolts must go through the back of each horizontal track as a safety bolt to prevent the top roller from rolling out the back of the horizontal track. (See Figures 13,13B)

STEP 17 CONTINUED

Fasten optional punched angle to the ceiling with 5/16" X 2" lag screws. Do not fasten a punched angle brace until STEP 27.

Make sure the curved front ends of the horizontal tracks and the vertical tracks line up. Tighten the remaining bolts and nuts.

Doors over 14' [5270] high or any horizontal track that deflects more than 1/2" [13] in 10' [3050] should also be center hung with punched angle.

Note: Martin 2" [51] horizontal tracks, for 7' [2130] to 14' [4270] high doors, are made with slotted holes. The horizontal track angles are fastened to the horizontal tracks slotted holes with 1/4" X 1/2" short neck carriage bolts and 1/4" lock nuts. If needed, to remove stress, loosen the bolts and nuts and move the horizontal tracks or horizontal track angles, then re-tighten the bolts and nuts. This procedure can also be used to slightly raise or lower the back of the horizontal tracks to miss an obstruction or provide a more perfect balance to the door in the open position. Raising the back of the horizontal tracks will help to reduce the open door spring tension. Lowering the back of the horizontal tracks will help to increase the open door spring tension. The above procedure of raising or lowering the back of the horizontal tracks, to improve the open door balance, is sometimes used by professional installers, only after completing STEP 26.

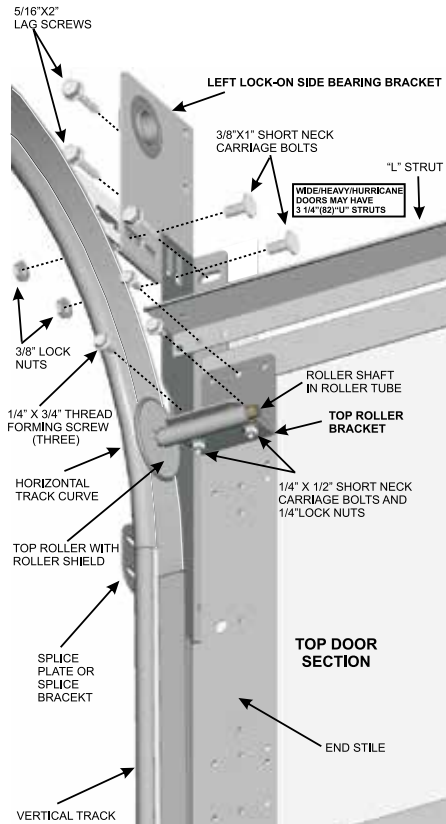

FIGURE 14A

STEP 18-19

STEP 18

MARTIN TOP ROLLER BRACKETS

Loosen the bolts and nuts on the top roller brackets. Slide the roller shaft into the roller tube of each roller bracket. Insert the roller into the curve of the horizontal track. The roller tube is on the bottom side of the top roller bracket. (See Figures 14A, 14B)

If the top door section has a strut, place the strut on or under the top roller bracket. (See Figures 14A, 14B) Fasten each top roller bracket to the stile. For added strength on heavy doors, fasten each top roller bracket to the stile with extra 1/4" X 3/4" thread forming screws. Adjust the top roller bracket so that the top door section lightly touches the header. Use enclosed top roller extension kit for high doors, make sure all bolts and nuts are tight. (See Figures 14A, 14B)

LOCK-ON SIDE BEARING BRACKETS

Rotate and fasten the left and right lock-on side bearing brackets to the horizontal track angle. (See Figure 14A, 14B)

STEP 19

PULL DOWN ROPE & OPTIONAL LIFT HANDLES

About 12" (310) above the center of the door, fasten the rope strap to the side of the reverse angle. Fasten the end of the pull down rope to the rope strap. (See Figure 14C) Fasten the other end of the pull down rope to the bottom roller bracket. (See Figure 14D)

WARNING! To help protect children, do not fasten pull down rope to an electrically operated door.

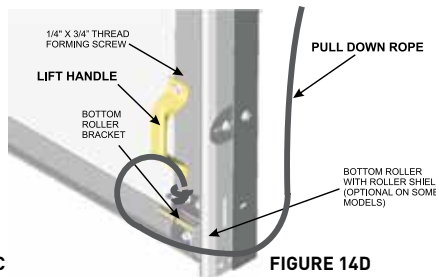
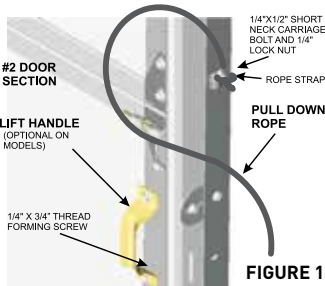
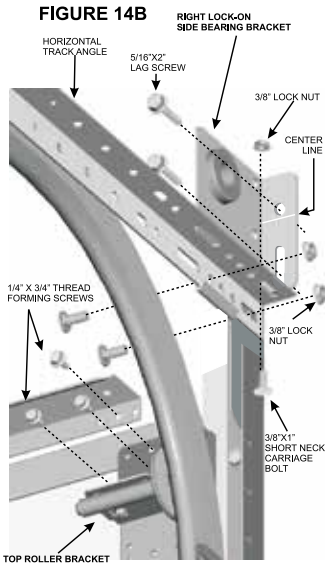

SPRING ASSEMBLY

FIGURE 15 - ONE TORSION-SPRING ASSEMBLY

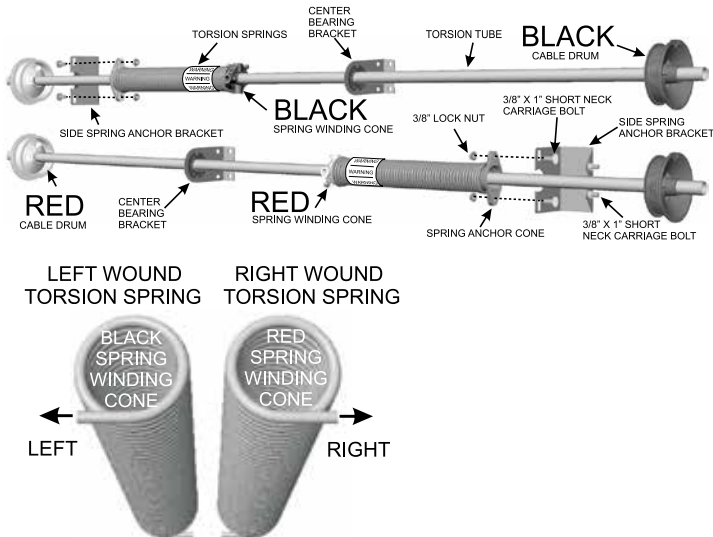

FIGURE 15A

ONE PIECE TORSION TUBE FOR DOORS UP TO 10'2" (3100) WIDE

APPROXIMATE TURNS ON TORSION SPRINGS TO BALANCE DOOR WITH *STANDARD CLEARANCE

DOOR HEIGHT	4" (102) CABLE DRUM	5 1/4" (133) CABLE DRUM	8" (203) CABLE DRUM
7' (2130)	8		
8' (2440)	9	6	
9' (2740)	10	7	
10' (3050)	11	8	
11' (3350)	12	8-9	
12' (3660)	13	9	
13' (3960)		10	
14' (4270)		11	
15' (4570)		11-12	
16' (4880)		12	
17' (5180)		13	
18' (5490)		13-14	
19' (5790)			9
20' (6100)			10

*SEE SUPPLEMENTS D AND E FOR HIGH-LIFT OR VERTICAL-LIFT

ATTENTION! Torsion springs can be damaged by dropping on or throwing against sharp objects. This may result in reduced spring life.

FIGURE 16 - ONE/TWO TORSION-SPRING ASSEMBLY

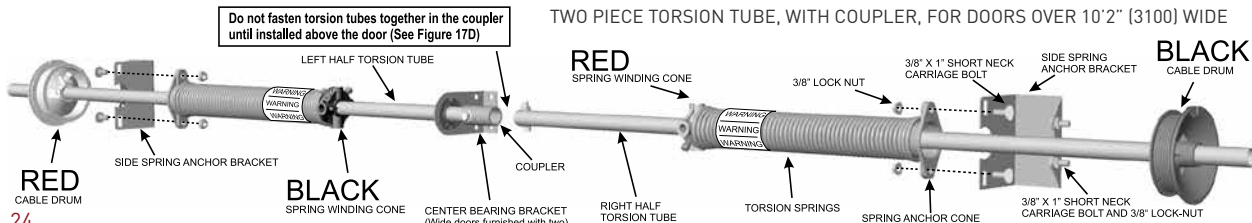

TWO PIECE TORSION TUBE, WITH COUPLER, FOR DOORS OVER 10'2" (3100) WIDE

Do not fasten torsion tubes together in the coupler until installed above the door (See Figure 17D)

STEP 20

STEP 20

TORSION SPRING ASSEMBLY

Observe the red and black color codes on the spring winding cones and cable drums and assemble correctly. All references to right or left are viewed from inside looking out through the door opening. ATTENTION: If the torsion spring(s) are reversed and fastened on the wrong side, they will back-wind. The door will only open part way and stop.

Put the torsion spring assembly together on the floor for one or two torsion springs as provided. Do not fasten torsion tubes together in coupler until installed above the door. (See Figure 17D) Fasten the spring anchor cones to the side spring anchor brackets. (See Figures 15,16) Extra heavy doors may have four springs provided.(See Supplement F)

For easy side spring anchor bracket assembly to the lock-on side bearing brackets at the end of STEP 23, two 3/8" x 1" short neck carriage bolts are fastened to each side spring anchor bracket with 3/8" lock nuts. The 3/8" lock nuts also act as necessary spacers for the wider cable drums used on doors higher than 8' (2440). (See Figures 18A,18B)

NOTE: Single and double wide doors may have one or two torsion springs as provided. A single torsion spring, on a one torsion spring assembly, may have a red or black spring winding cone. If red, the torsion spring is right wound and will be assembled on the right side. If black the torsion spring is left wound and will be assembled on the left side. The red cable drum is assembled on the left side. The black cable drum is assembled on the right side. The torsion tube furnished is at least 7" (179) longer than the length between the lock-on side bearing brackets. (See Figures 15,15A,16)

DOORS WITH ONE PIECE TORSION TUBE

Lift the torsion spring assembly up and slide the torsion tube into each lock-on side bearing bracket. Flex torsion tube as needed. (See Figure 15, 17A,17C)

BEARING BRACKET

FIGURE 17A

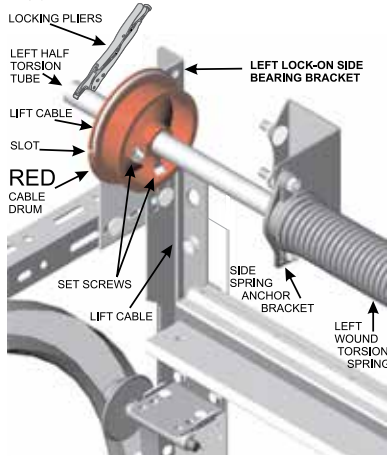

FIGURE 17C

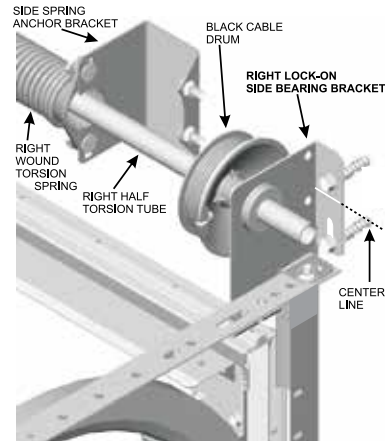
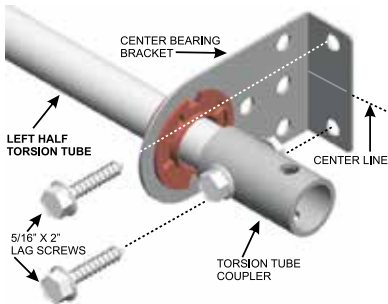

FIGURE 17B



ALTERNATE 17B

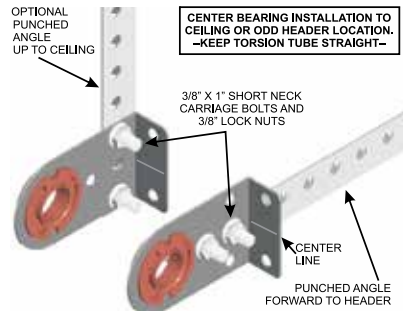
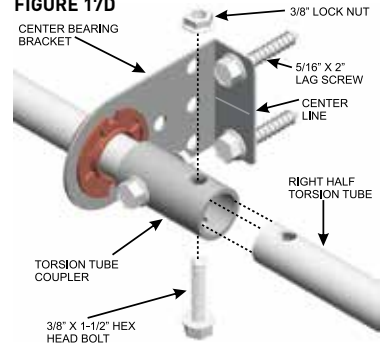

FIGURE 17D



STEP 21-24

CENTER BEARING BRACKET

Observe lock-on side bearing brackets center line. Mark same location and drill holes for center bearing bracket. If its on the same surface as the lock-on side bearing brackets, it will fasten directly to the header. (See Figure 17B). For odd surfaces add punched angle. Keep the torsion tube straight! (See Alternate 17B) Wide doors are furnished with two center bearing brackets.

Lift the left half of the torsion spring assembly up and slide the torsion tube into the left lock-on side bearing bracket. (See Figure 17A) Fasten the center bearing bracket. (See Figure 17B)

Lift the right half of the torsion spring assembly up and slide the torsion tube into the right lock-on side bearing bracket. (See Figure 17C) Slide the right torsion tube into the torsion tube coupler and fasten. (See Figure 17D)

STEP 21

Heavy Commercial size doors are furnished with 2 extra torsion springs, which must be fastened to two extra center spring anchor brackets. (See Supplement F)

STEP 22

Starting at the left side, draw the lift cable up behind the roller shafts between the vertical track and the left side of the door. Slip the lift cable through the slot in the left side of the cable drum. Pull on the lift cable until the lift cable button stops and is tight against the red cable drum slot. Wind the remaining lift cable onto the red cable drum by hand, carefully following the groove. Push the red cable drum against the left lock-on side bearing bracket and tighten the two or three 3/8" set screws until you feel pressure on your wrench then tighten 1 extra turn. The set screws dimple slightly into the torsion tube. Rotate the red cable drum and torsion tube until the lift cable is taut. Clamp locking pliers to the torsion tube and brace them against the header to keep the lift cable taut and from unwinding. (See Figure 17A)

STEP 23

Repeat the procedure in STEP 22 for attaching the lift cable, on the right side, to the black cable drum. Do not remove the locking pliers! The lift cable must be set equally taut. If black cable drum is fastened first, the lift cables may not be equally taut. (See Figure 17C)

After fastening cable drums, fasten the side spring anchor brackets to the lock-on side bearing brackets. (See Figure 18A,18B)

STEP 24

Fasten the optional commercial door inside side latch lock, if provided, to the inside of the #3 door section.

FIGURE 18A

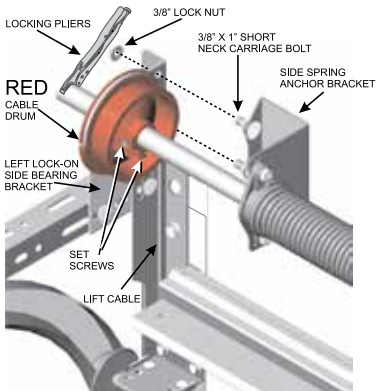

FIGURE 18B

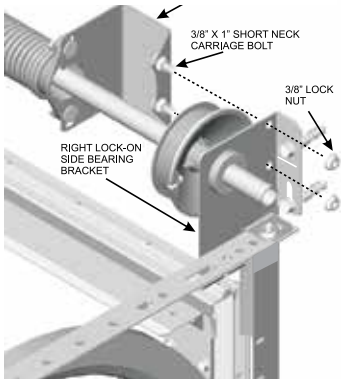

FIGURE 19A

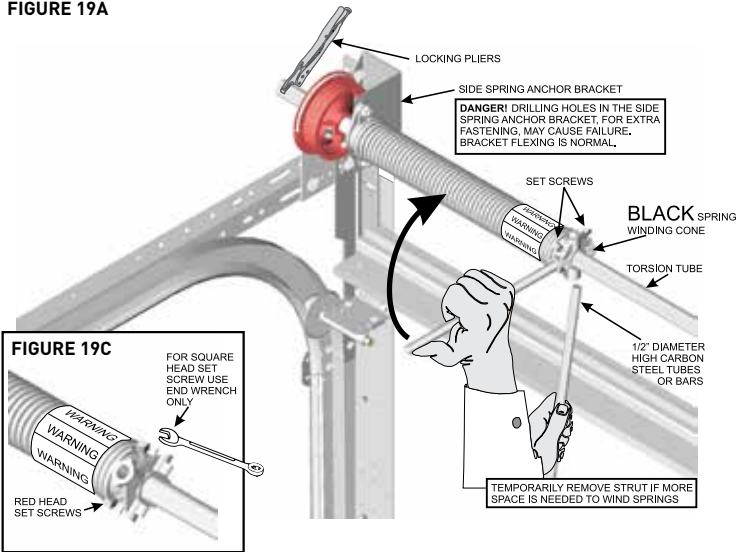
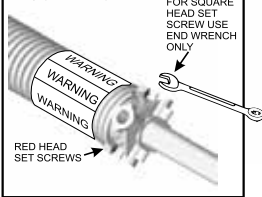

FIGURE 19C



WARNING! TORSION SPRINGS CAN CAUSE SERIOUS INJURY OR DEATH! KEEP HANDS CLEAR OF WINDING CONES. IF NOT SURE, STOP NOW! CALL A TRAINED MARTIN DOOR DEALER.

STEP 25-26

STEP 25

Check to make sure the lock is engaged, or that the door is clamped down so it will not open. If using 4" (102) cable drums, wind the torsion springs about 8 turns for 7' (2130) high doors or about 9 turns for 8' (2440) high doors. The horizontal paint stripe on each torsion spring will rotate and match each turn. Use only 1/2" (12.7) dia. high carbon steel bars or tubes that closely fit the spring winding cone holes. Insert the specially designed bars or tubes completely to the bottom of the holes. (DO NOT use screw driver, etc.) Wind each torsion spring in an upward direction 1/4 of a turn at a time. When fully wound, tighten down the two 3/8" set screws 1/2 to 1 turn into the torsion tube. Caution: The set screws should dimple slightly but not puncture the torsion tube. (See Figure 19A, 19B, 19C).

To reduce the friction on the rotating spring coils, oil the spring coils during "Final Check List".

STEP 26

Remove the locking pliers on the torsion tube. Release the lock or remove the clamp holding the door in place. Slowly raise the door part way to check for balance. Be sure the door is rolling free and not binding or rubbing. If the door is heavy to lift, increase the torsion spring tension. If the door goes up too fast, decrease the torsion spring tension. It is better for the door to open a little fast than be too heavy. If additional torsion spring adjustment is made, follow the procedures and cautions outlined in STEP 25. Add or delete 1/4 turn at a time, alternating torsion springs. Recheck the balance. Repeat this procedure until the door rolls smoothly with a satisfactory balance. Be sure to clamp locking pliers on the torsion tube and clamp or lock the door in the closed position before each adjustment. Also read "NOTE" in STEP 17.

STEP 27

FIGURE 20 3/8" X 1" SHORT NECK CARRIAGE BOLTS AND 3/8" LOCK NUTS

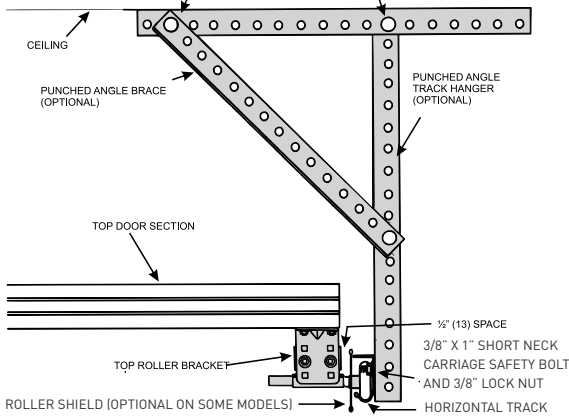

OPTIONAL SLIDE BOLT LOCK & LIFT HANDLE

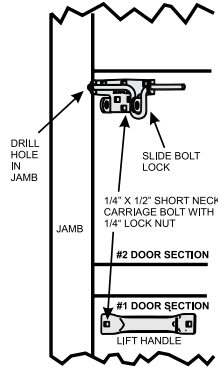

OPTIONAL COMMERCIAL DOOR INSIDE SIDE LATCH LOCK

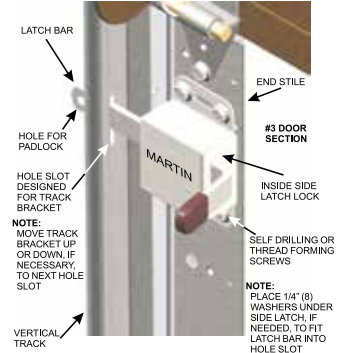

STEP 26 CONTINUED

The Lift Cable Tension Adjuster shown in Figure 3A allows for the door, the door opening and the tracks to be a small amount out of plumb, level and square. However, if they are out too much, one of the lift cables may fall off the cable drum as the bottom of the door opens to the curve. If this happens, first check to make sure the horizontal tracks are parallel and square with the door. The cable drums must be securely fastened to the torsion tube. **WARNING!** If the problem is caused by loose cable drum set screws, which allowed cable drum slippage, the torsion springs must have their tension released before a satisfactory cable drum adjustment can be made. Start over again at STEP 22. Also check the door, the door opening and the tracks for plumb, level, and square.



WARNING! EXTREME CAUTION MUST BE EXERCISED WHILE ADJUSTING THE TORSION SPRINGS!

STEP 27

With the door fully open and working free, make final adjustments to the horizontal tracks. Leave about 1/2" (13) space between the side of the door and the horizontal track, then fasten the punched angle brace with 3/8 X 1" short neck carriage bolts and 3/8" lock nuts. The punched angle track hanger should be vertical. (See Figure 20)

STEP 28



WARNING! Be sure the door is in the down position if the punched angle track hanger needs to be unfastened and moved to another position.

Note: Doors over 14' (5270) high and any extra heavy door that causes the horizontal tracks to deflect more than 1/2" (13) in 10' (3050) should also be center hung and braced with punched angle to support the weight.

STEP 28

Install controlled descent device kit if furnished.

FINAL CHECK LIST

1. The door should only lightly touch the jambs or reverse angle shields.
2. All fasteners must be tight.
3. Oil or wax all moving part areas as explained on the front page under "MAINTENANCE".
4. A finished installation should include a clean garage door and garage floor.

CONGRATULATIONS! Enjoy your new Martin Garage Door. Tell your friends

DENTS: All roll formed and stamped steel can be dented, however, Martin regular and insulated high tensile steel door sections are rated among the strongest and most dent resistant in the world.

Martin door sections do not require insulation bonded to them for strength. Because of this unique construction, many dents can be easily repaired by a trained Martin dealer. It may not be necessary to replace a door section or a complete door to avoid the prolonged appearance of a damaged surface.

DENT REPAIR: Regular and insulated doors are usually repaired in the closed position. The insulation must be removed, the dent is tapped on each side until the embossed surface is restored to near original. The insulation is replaced and detailed. New steel backing is available.

CAUSES: During a lifetime, various accidents can cause a dent, including golf balls, bicycles, roller blades, tools, baseballs, rocks, etc.

SUPPLEMENT B

CLEARANCE AND MODIFICATIONS

2" [51] TRACK MODIFICATIONS

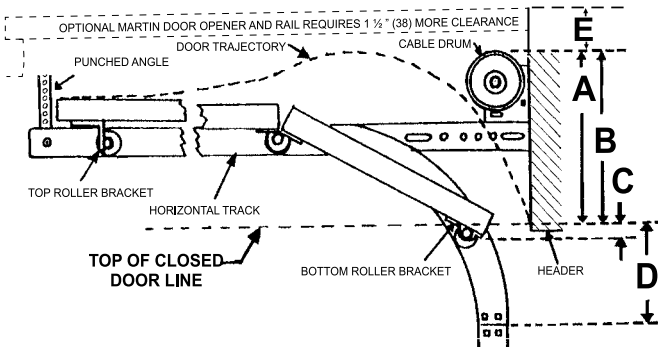

LOW CLEARANCE: See page 20, SUPPLEMENT C-I for optional 8 1/2" [216] Clearance. See SUPPLEMENT C for optional 4 1/4", 2 1/2" [108, 64] Clearance.

INCREASE CLEARANCE 3" and 6" [76 and 152]: See page 11, Figure 13C for optional VERTICAL TRACK EXTENSION KITS.

HIGH CLEARANCE / HI-LIFT : See optional SUPPLEMENT D for increasing clearance 8" TO 133" [203 TO 3380] .

VERTICAL-LIFT : See optional SUPPLEMENT E. Requires twice the door height plus 12" [310].

CLEARANCE / MEASUREMENTS

- A. REQUIRED CLEARANCE ABOVE TOP OF CLOSED DOOR FOR CABLE DRUMS.
- B. REQUIRED CLEARANCE FOR DOOR TRAJECTORY.
- C. DOOR OPEN - AT REST - UNDER TOP OF CLOSED DOOR LINE.
- D. TOP OF VERTICAL TRACKS TO TOP OF CLOSED DOOR (STEP 16 INSTALLATION MEASUREMENT)
- E. ALLOW 1 1/2" [38] ABOVE DOOR TRAJECTORY FOR A MARTIN DOOR OPENER.

DIAMETER OF CABLE DRUMS		4" (102)	5.25" (133)	8" (203)
2" (51) TRACK	A	12" (310)	14" (360)	18" (460)
	B	11" (279)	11" (279)	11" (279)
	C	2" (51)	2" (51)	2" (51)
	D	8" (203)	8" (203)	8" (203)
3" (76) TRACK	A	17" (430)	19" (480)	23" (580)
	B	15" (380)	15" (380)	15" (380)
	C	0" (0)	0" (0)	0" (0)
	D	12" (310)	12" (310)	12" (310)

DOOR SECTION MODIFICATIONS (STEEL/COPPER DOORS)

If needed, a Martin Steel Sectional Garage Door allows maximum, on the job, modifications by experienced installers.

After modifications are made, as instructed, the operation and visual look of the door should still be close to factory production.

DECREASE DOOR WIDTH

The pop style rivets, used in each end stile to manufacture Martin Steel/Copper Door Sections, provide superior strength, yet are easy to remove and replace.

To reduce width of door sections to fit a narrow door opening:

1. Drill the heads off the end stile rivets.
2. Remove the end stiles.
3. Cut the door sections.
4. Re-drill the door sections for the end stile rivets.
5. Replace the end stiles with new rivets.

INCREASE DOOR HEIGHT 2-1/2" (64)

1. Use rivets or screws to fasten finger shield clips to the top of the top door section.
2. Snap a Finger Shield into the finger shield clips.
3. This modification requires a 3" (76) vertical track extension kit.
See STEP 16 and Figure 13C.

SUPPLEMENT C-1

LOW CLEARANCE TRACK WITH TORSION SPRINGS AT THE FRONT

FIGURE C1

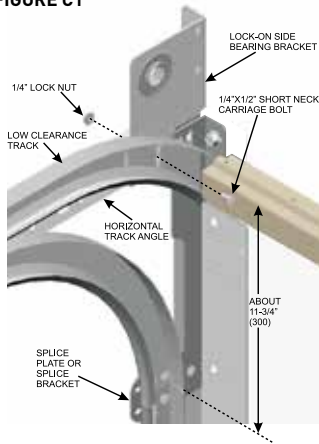

FIGURE C2

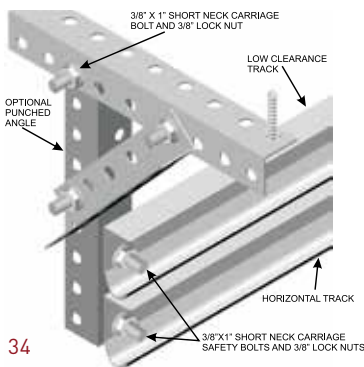

FIGURE C3

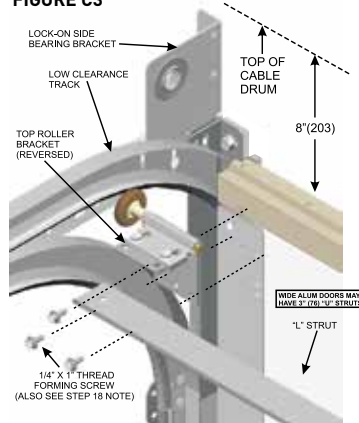
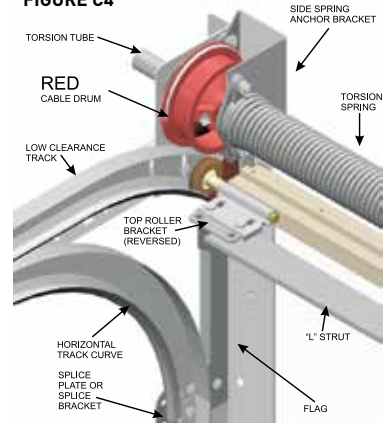

FIGURE C4



- 8 1/2" [216] clearance is required above top of closed door with 4" [102] cable drums.
- 10" [254] clearance is required above top of closed door with 5-1/4" [133] cable drums.
- Cut off the bottom of the reverse angle shields and the vertical tracks 3-3/4" [95].
- The top of the vertical track should be about 11-3/4" [300] from the top of the closed door.

STEPS 1 to 16

Follow the regular instruction manual except place five cardboard strips on each side of the door opening, under the reverse angle shields and under the door. Add or subtract if floor is out of level. See STEP 1 and 8.

NOTE: Setting door, track, and RA shields on a level floor with no cardboard strips may save 1/2" [13] of the required clearance. However, the adjustments of the low clearance tracks and top roller brackets will be limited.

FIGURE C5

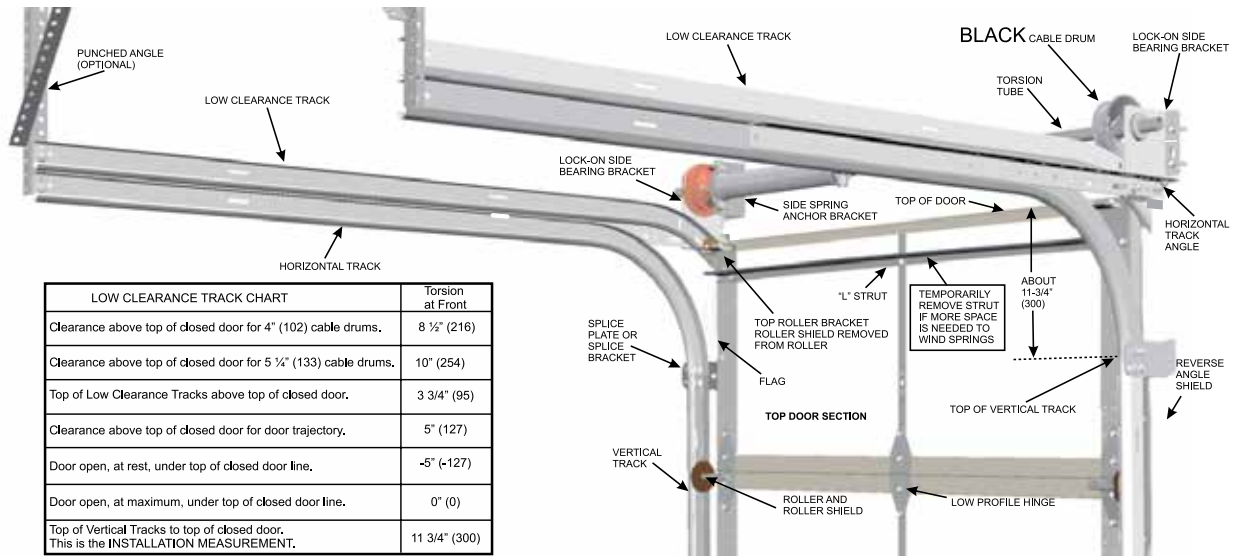

LOW CLEARANCE TRACK CHART	Torsion at Front
Clearance above top of closed door for 4" (102) cable drums.	8 1/2" (216)
Clearance above top of closed door for 5 1/4" (133) cable drums.	10" (254)
Top of Low Clearance Tracks above top of closed door.	3 3/4" (95)
Clearance above top of closed door for door trajectory.	5" (127)
Door open, at rest, under top of closed door line.	-5" (-127)
Door open, at maximum, under top of closed door line.	0" (0)
Top of Vertical Tracks to top of closed door. This is the INSTALLATION MEASUREMENT.	11 3/4" (300)

FIGURE C6

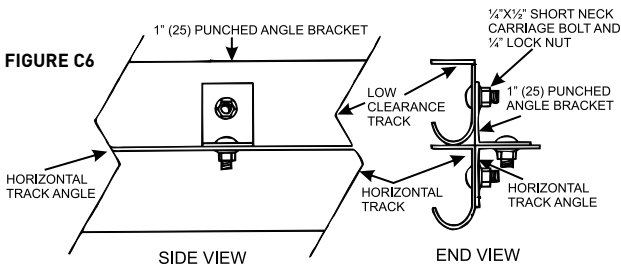

STEP 17

Follow regular instruction manual except the top of vertical tracks should be about 11-3/4" [300] down from the top of the closed door. (See Figure C1)

- Fasten the lock-on side bearing brackets to the horizontal track angles as explained in STEP 18, also Figures 14A and 14B.

- Fasten the front of the low clearance tracks above the horizontal tracks to the third hole of the horizontal track angle. (See Figure C1)
- Fasten the back of the low clearance tracks above the horizontal tracks to the punched angle. (See Figure C2)
- For doors over 8' (2440) high, cut a 1" (25) punched angle bracket from a punched angle and fasten the punched angle bracket in the holes provided, near the center of the low clearance tracks and the horizontal track angle. [See Figure C6]

STEP 18

Follow the first paragraph of the regular instruction manual, except turn the top roller brackets over and reverse the roller tubes.

Adjust the roller tubes close to the door section. Fasten each top roller bracket in the holes provided in the stiles. (See Figures C3,C4)

NOTE: Fasten top roller brackets to the top outside holes. The matching top two outside holes are in the stiles, under the metal skin.

The 1/4 X 3/4" Thread Forming Screws will penetrate the metal skin while turning. The strut if provided, may install 2" (51) lower.

NOTE: Remove the roller shields from the top rollers.

ADJUSTMENTS: The roller tubes can be adjusted back slightly to keep the top door section against the header. The vertical slot at the front of the low clearance track is provided so the track can move up and down slightly to also adjust the top door section against the header.

STRUT: If the top door section has an "L" strut, the strut must be turned over and fastened over the top roller brackets or fastened to the stiles as close to the top of the door as possible. (See Figure C3,C4)

STEPS 19 TO 29 Follow the regular instruction manual. (Step 26 note: Temporarily remove strut if more space is needed to wind the spring(s).)

EXTRUDED
ALUMINUM
DOORS

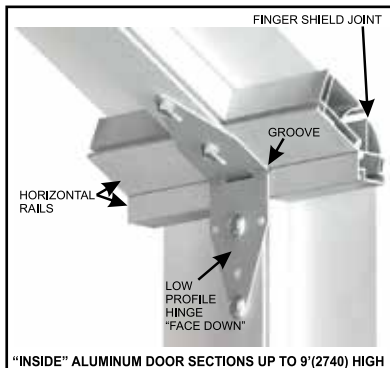

FIGURE 1

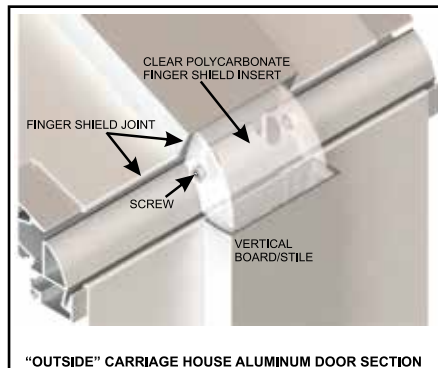

FIGURE 2

EXTRUDED ALUMINUM DOORS

1. Stack sections following Aluminum Door Section Placement Chart.
2. For doors up to 9'(2740) high, fasten all low profile hinges "face down" into the grooves provided in the horizontal rails with 1/4" x 3/4" thread forming screws. Fasten to stiles and rails using the pre-drilled 1/8"(3) holes. See FIGURES 1 and 2. For doors over 9'(2740) high, fasten all low profile hinges regular "face up".
3. Use reasonable care in fitting/stacking each Carriage House Door section over the clear polycarbonate finger shield inserts that are screwed inside the vertical board/stile designs. See FIGURE 2.
4. Install Lock-on Bottom Roller Bracket as shown on page 5.
5. For Antique Hinge, decide, level, mark, and drill one 1/8"(3) hole through the horizontal rail. See FIGURES 3 and 4. Attention! Do not drill through second aluminum extrusion or steel profile. See FIGURE 4
6. Fasten Antique Hinge with one (5/8"(17) long) stainless steel black screw provided.
7. Level the Hinge with the Horizontal Rail, then drill the other three 1/8"(3) holes in the horizontal rail. Fasten the hinge with three additional (5/8"(17) long) stainless steel black screws provided. See FIGURES 3, 4 and 5
8. Decide, mark, drill, and fasten the remaining hinges and handles following the completed door example. See FIGURE 5

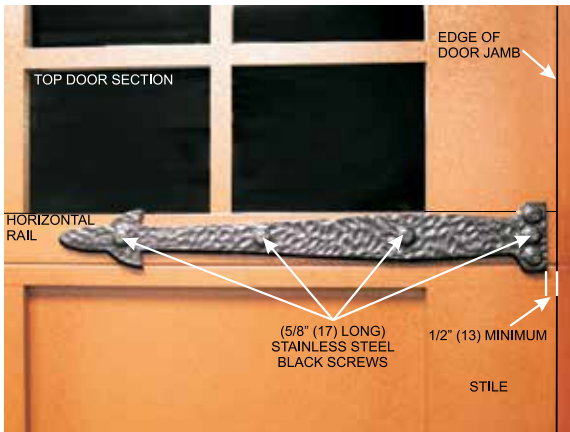

FIGURE 3

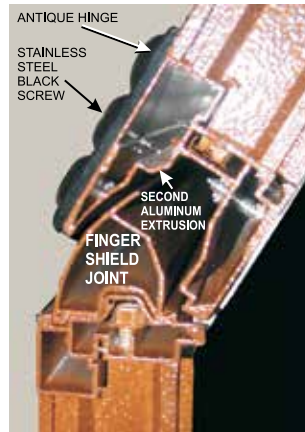

FIGURE 4

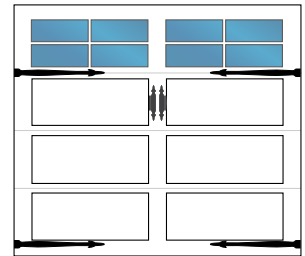
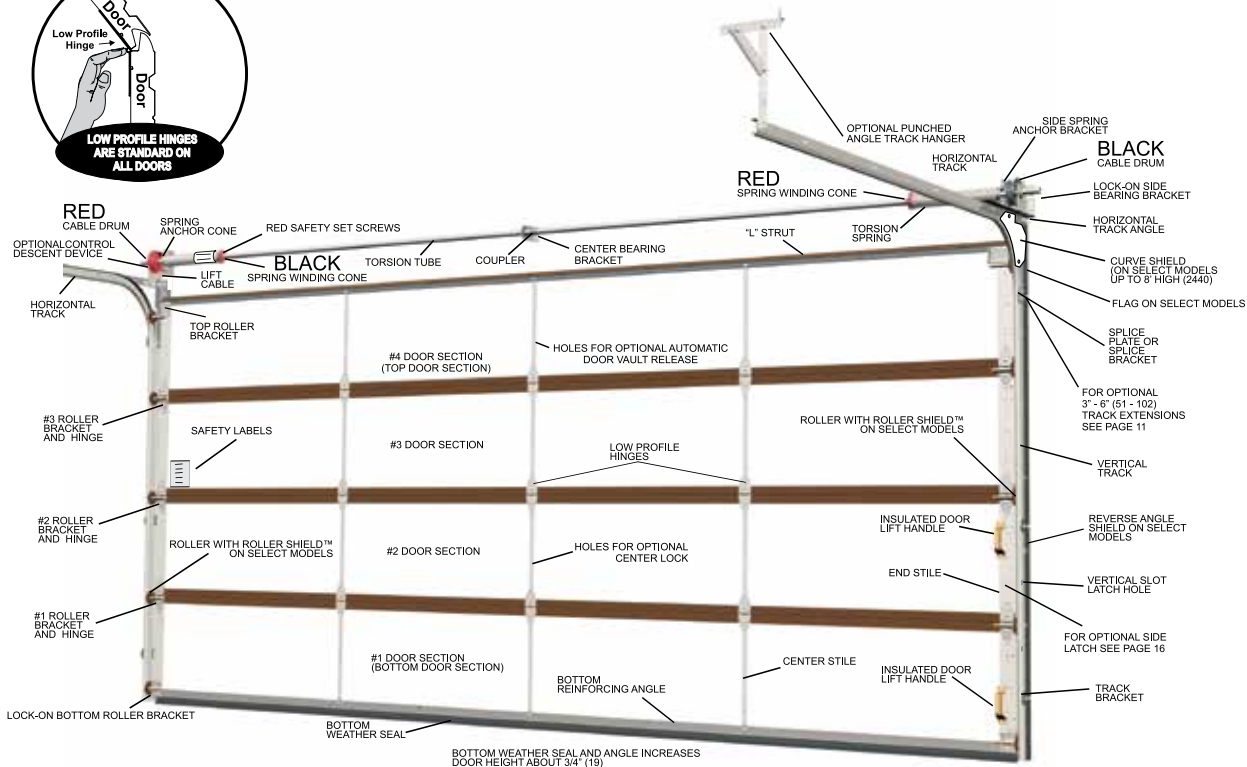
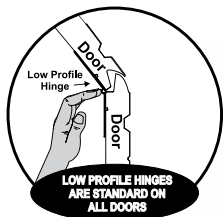

FIGURE 5

GARAGE DOOR ASSEMBLY

- SAFETY SECTION ASSEMBLY
 - SAFETY TRACK ASSEMBLY
 - SAFETY SPRING ASSEMBLY
- HELPS PREVENT GARAGE DOOR INJURIES TO CHILDREN AND ADULTS



60-MINUTE PAINTING INSTRUCTIONS

FOR RE-PAINTING, SEALING OR CUSTOMIZING YOUR STEEL DOOR COLOR

When a steel door is installed and in the closed position, paint the outside surface of the door only. It is not necessary to paint the door sections on the edges, joints and inside like a new wood door requires. Paint cannot dry in between joints. One coat of paint should cover if the steel surface is prepared properly. This is done by cleaning and lightly sanding as shown in steps 1, 2, and 3. Because the new paint is being applied to a stable painted surface, the new paint should last for many years. Copper door clear sealer may need to be repeated often. We recommend that copper doors be allowed to age gracefully.

Your local paint store will advise you on the type and quality of paint to purchase. Follow any additional instructions on the paint can, especially proper temperature conditions and ventilation.

NOTE: It may be possible to re-new the look of an older door without re-painting. See “MAINTENANCE” on front page for cleaning and waxing.

STEP 1 - 10 MINUTES

Close the door, then wash it with a mild detergent to remove any dirt, oil or grime.

STEP 2 - 5 MINUTES

Spray off with water. The washing process is necessary for the new paint to adhere to the surface.

OR: Wipe door clean with a good quality paint thinner.

STEP 3 - 10 MINUTES

When the door is completely dry, lightly sand. The sanding process is necessary for the new paint to adhere to the surface.

STEP 4 - 15 MINUTES

Dust off, then raise the door. Place a protective cover over the jambs, header and floor.

STEP 5 - 20 MINUTES

Close the door and paint using any good quality paint or clear coat sealer. Paint only the exposed outside surface. A spray gun will usually apply a more even coat!

STEEL DOOR PAINTING THEORY:

Martin Steel Door sections are manufactured with hot-dipped galvanized steel, which is one of the best known methods for rust protection even when scratched, cut, punched, drilled or broken. In addition the door sections receive two coats of baked-on semi-gloss enamel. This paint process not only adds beauty to the door sections but is also necessary for the roll forming Process. Dirty finger marks are easily wiped clean following installation. See “MAINTENANCE” on the front page.

It is almost impossible to avoid small manufacturing, shipping and installation marks/scratches. These do not affect the overall long lasting beauty of the door. We do not recommend touch-up paint unless absolutely necessary. Touch-up and spray paints may be more visible than the mark/scratch.

MARTIN ADVANTAGE

Dear Owner,

We continually try to improve our fine sectional garage doors and electric door openers. We value any comments you would like to make.

Thank You,

Mail or Fax comments to:

Martin Door
Salt Lake City, Utah 84127-0437 USA
FAX: (801)977-4222
www.martindoor.com

NOTE: For comments regarding other brand automatic garage door openers, the condition of the garage door opening or the installation of the garage door or opener, please contact your local installation dealer.