



EARTHQUAKE ENGINEERING RESEARCH INSTITUTE

499 14th Street, Suite 320

Oakland, California 94612-1934

Phone +01 (510) 451-0905 Fax +01 (510) 451-5411

www.eeri.org

REDUCING EARTHQUAKE DAMAGE THROUGH QUALITY CONSTRUCTION

CREATED BY **MARYANN PHIPPS**

Slides contributed by: MaryAnn Phipps, Chris Poland

Script Assistance: Cynthia Hoover, James Russell

Prepared by: Xena van de Walle, EERI

[BACK TO MAIN MENU](#)

INTRODUCTION

This presentation was created and originally presented by Maryann Phipps, formerly Principal, *Degenkolb Engineers*, at the EERI Workshop on Construction Quality and Seismic Education, April 1997.

Chris D. Poland, President, *Degenkolb Engineers*, also provided slides.

Cynthia Hoover, formerly Structural Inspector, *City of Seattle*, and James Russell, *Codes Consultant*, assisted in editing the script.



Everyone has a role in the construction process—the owner, the designer, the construction worker, the seismologist, the plan reviewer and the inspector. All of these roles are important. A successful construction project is very much a team effort. Today we are going to focus on a couple of key team players, and how each team member plays a vital part in insuring the good performance of a building in an earthquake.

Slide #1



Our focus today is on what goes on out in the field, and the importance of each member of the construction team, particularly the construction worker and the inspector. We hope to give you a greater appreciation for the consequences of poor workmanship or inadequate inspection and the important role that the trades and inspectors play in insuring good building performance during an earthquake. A good structural design is the starting point to achieve satisfactory earthquake performance, but even the best engineer's efforts can be seriously compromised by errors in the construction process. Considering the number of opportunities for mistakes during that process, based either on the vast number of construction operations that must be performed or simply the number of individuals involved, it becomes very clear that those who actually construct and inspect structures can have the greatest impact on building performance.

Slide #2



We are going to begin by looking at steel construction. In steel construction it is critical that the connections are made in accordance with the drawings, that the proper materials are used, both the steel itself and in the connectors, and that standards of practice are carefully followed, such as the guidelines that come from the American Welding Society.

Slide #3



The welders, of course, play an absolutely critical role in insuring the good performance of a building because the connections they weld provide the needed strength and/or ductility (flexibility) the building needs to move in an earthquake.

Slide #4

Construction Quality

Earthquake Engineering Research Institute



Good inspectors are also critical to the good performance of steel frame buildings, since they need to make sure that the drawings have been followed and that the connections are right. In fact, both trades workers and inspectors must have a conceptual understanding of a "complete load path", the pathway through which earthquake forces are transmitted through a building's structure to its foundation. Everyone needs this basic knowledge and the understanding that any flaw may become a fatal "weak link" in the structural system.

Slide #5



We learned in the Northridge, California earthquake in 1994 that without excellent quality control during the construction of welded moment steel frame buildings, we can end up with cracking in the connections. We need good quality inspectors overseeing good quality welders. Here we see a crack in the column where the bottom flange of a beam frames into the column. This connection is in a welded steel moment frame damaged in Northridge.

Slide #6



This is an exterior elevation of a four-story steel braced frame building damaged in the Northridge earthquake. The building was designed in accordance with the 1985 Uniform Building Code.

Slide #7



Dozens of steel braces failed in this building. One reason is because of incomplete welding of the brace to the gusset plate. The right side was welded and the left side was not.

Slide #8

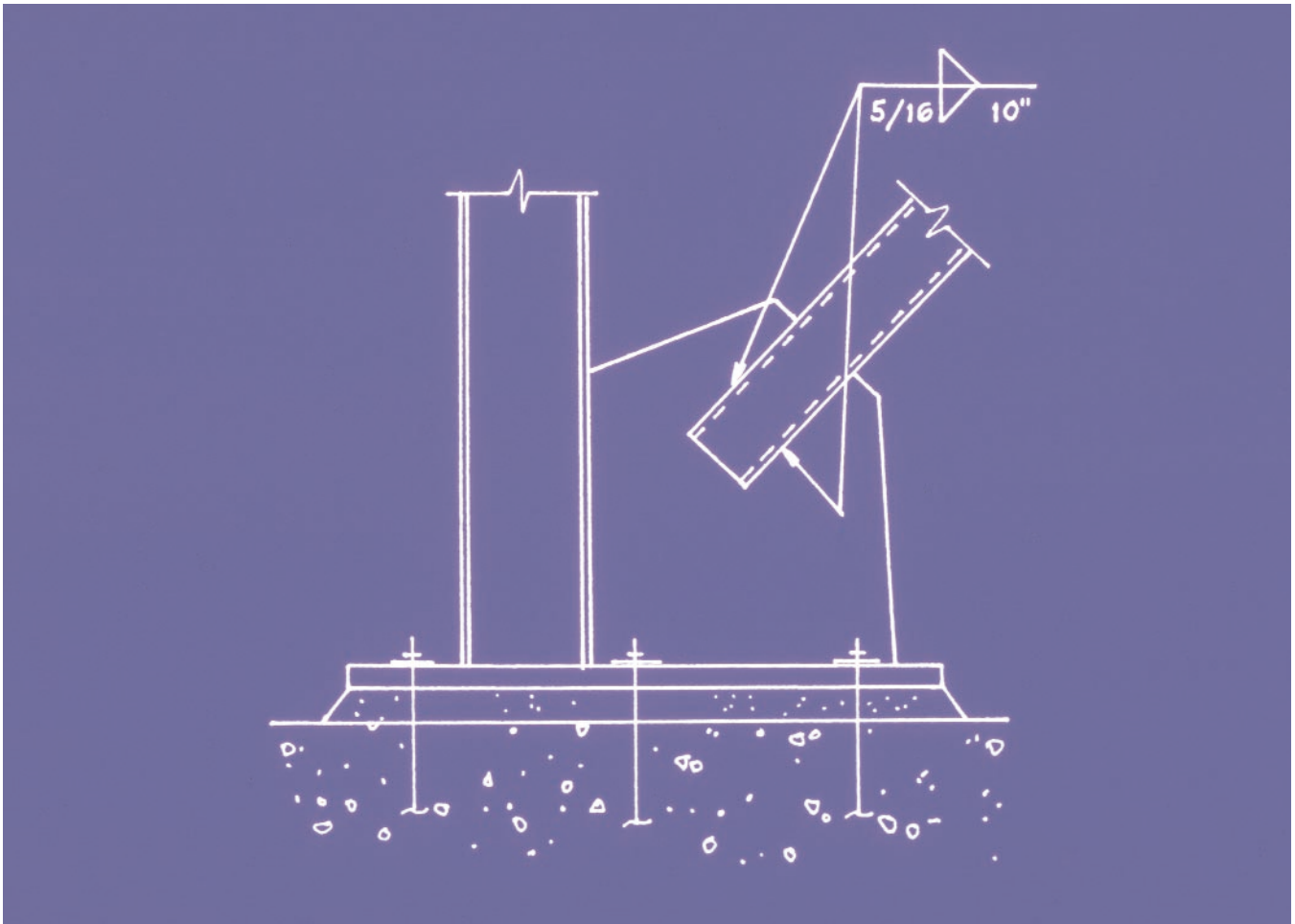

This is a connection detail drawing showing a correct weld symbol for both side welding of a brace to a gusset plate.

Slide #9



This is the inside of a two-story steel braced frame in Palo Alto, California damaged in the 1989 Loma Prieta earthquake. Problems were caused in that earthquake because the roof diaphragm has to be able to transfer the load to the steel braced frame. As you can see here the roof deck was a steel metal deck without concrete fill. This deck acts as a diaphragm and the load should have been transferred through a direct connection between the deck and the frame.

Slide #10



Unfortunately the welder welded right through the deck. There was poor quality control on the welder's part in making the connection, and poor control on the part of the inspector who didn't notice or didn't have time to check. Of all the deck to beam welds that were made, these are the most critical because it is at this location that horizontal earthquake forces are transferred to the frame that is designed to resist those forces.

Slide #11



Quality control doesn't end with the construction of the building. It continues on with maintenance. This is a light steel braced frame building. After construction the windows were added, cutting off the braces. This modification completely obliterated the lateral system in this location.

Slide #12



The bottom braces won't do any good in an earthquake because they are unable to transfer any kind of earthquake load from the frame above to the foundation.

Slide #13



Now let's talk a bit about concrete construction. In order for concrete to perform as expected in an earthquake, it's important that the proper materials are used, the proportions in the mix are correct, that it is placed properly to provide uniform prescribed strength, and that it is adequately cured.

Slide #14



This is the Kaiser Convention Center in Oakland, California. During an evaluation of the expected seismic performance of the building, conducted as part of a renovation, concern was expressed about the quality of the concrete in the walls. The engineers listened, by tapping along the walls at various intervals and decided that the walls sounded hollow.

Slide #15

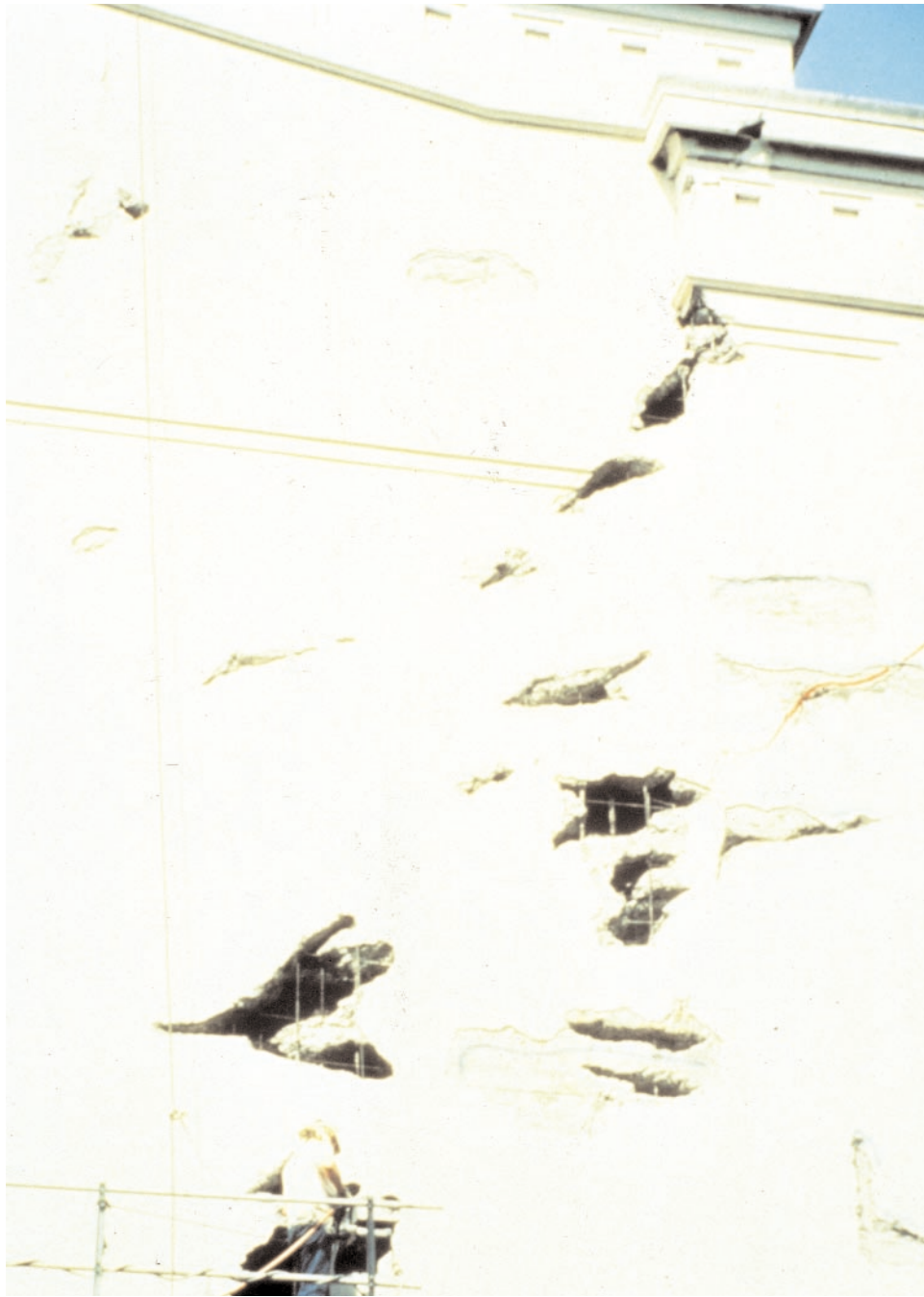

They took out a lot of loose material. Without appropriate vibration to consolidate the concrete as it is poured, and close observation by inspectors during concrete pouring operations you can get rock pockets and voids which seriously weaken the walls.

Slide #16



This is a horizontal construction joint in a wall. This is a very vulnerable element in a building. It is a weakened plane to begin with, and the joint is critical to the ultimate quality of the wall. Just before you pour the concrete you must make sure the joint is clean. Otherwise, during an earthquake, there will be a tendency for sliding along the joint.

Slide #17



Now we are going to talk about the role of rebar in providing good performance during an earthquake. In order to be effective, rebar must be the correct size, and must be located as shown in the drawings.

Slide #18



In earthquake country reinforcement is used to provide confinement for the concrete. Confinement is what gives concrete its ductility. Without proper confinement, concrete is brittle, and breaks apart under the movement caused by an earthquake.

Slide #19



This is a concrete column that supported a 5-story concrete office building that was damaged in the 1972 Philippines earthquake.

Slide #20

Construction Quality

Earthquake Engineering Research Institute



The column failed because all of the column ties were cut so a roof drain could be installed. This is what happens if you have no ductility. This is a dramatic illustration of the effect the "non-structural" trades can have on a building's performance in an earthquake.

Slide #21



In this slide we can see a rebar anchor that had been placed too close to the edge. Location is critical to rebar performing as it should during an earthquake. When it is too close to the edge, as here, it won't be able to provide the necessary confinement for the concrete. The placement of rebar is very important. Even small deviations in rebar location can significantly reduce concrete's strength and ductility.

Slide #22



This is a two story steel braced frame building that was damaged in the Loma Prieta earthquake.

Slide #23

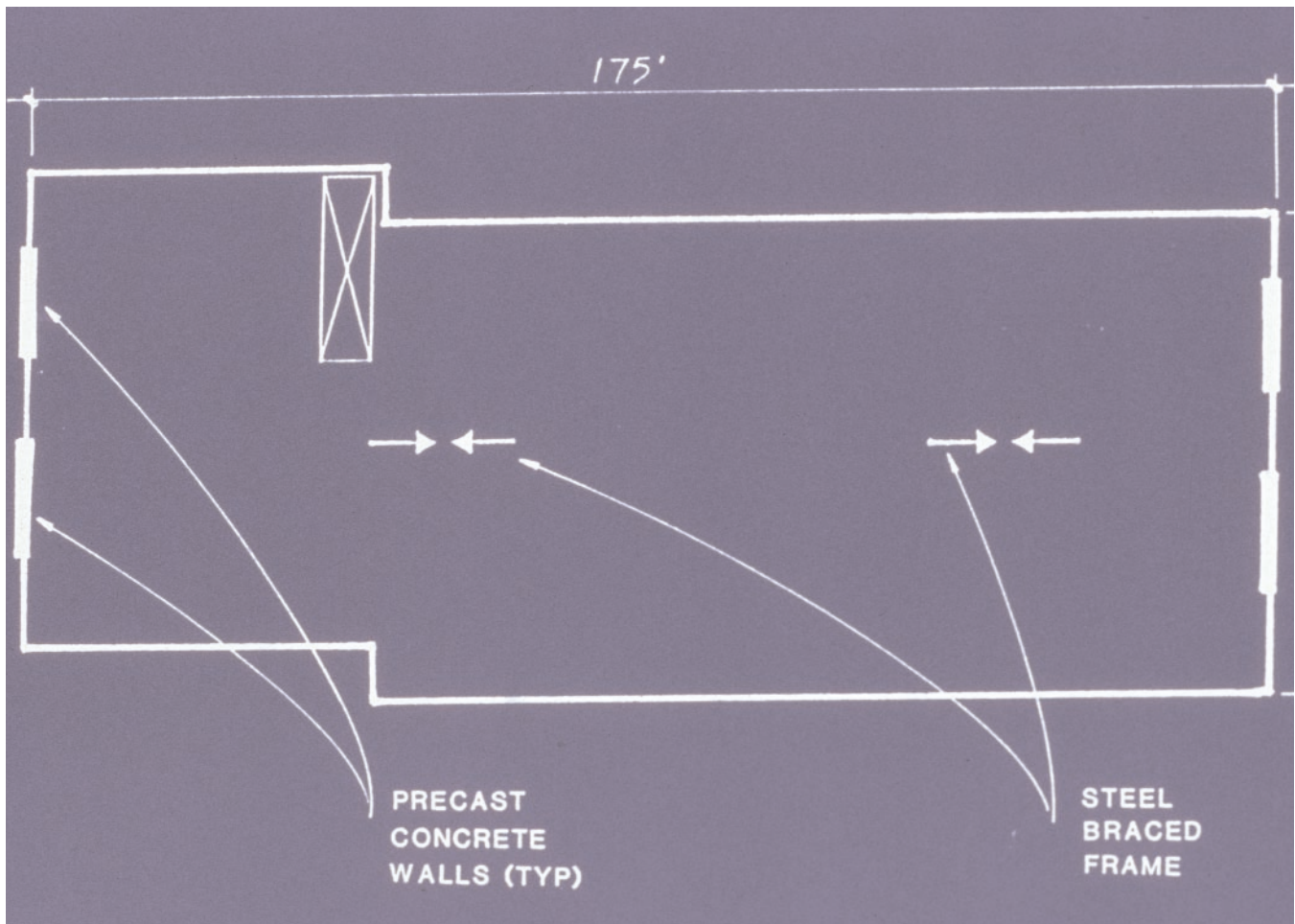

This is a floor plan of the building. You can see that the lateral system for the building in the short dimension direction, also called the transverse direction, consists of concrete shear walls at both ends of the building.

Slide #24

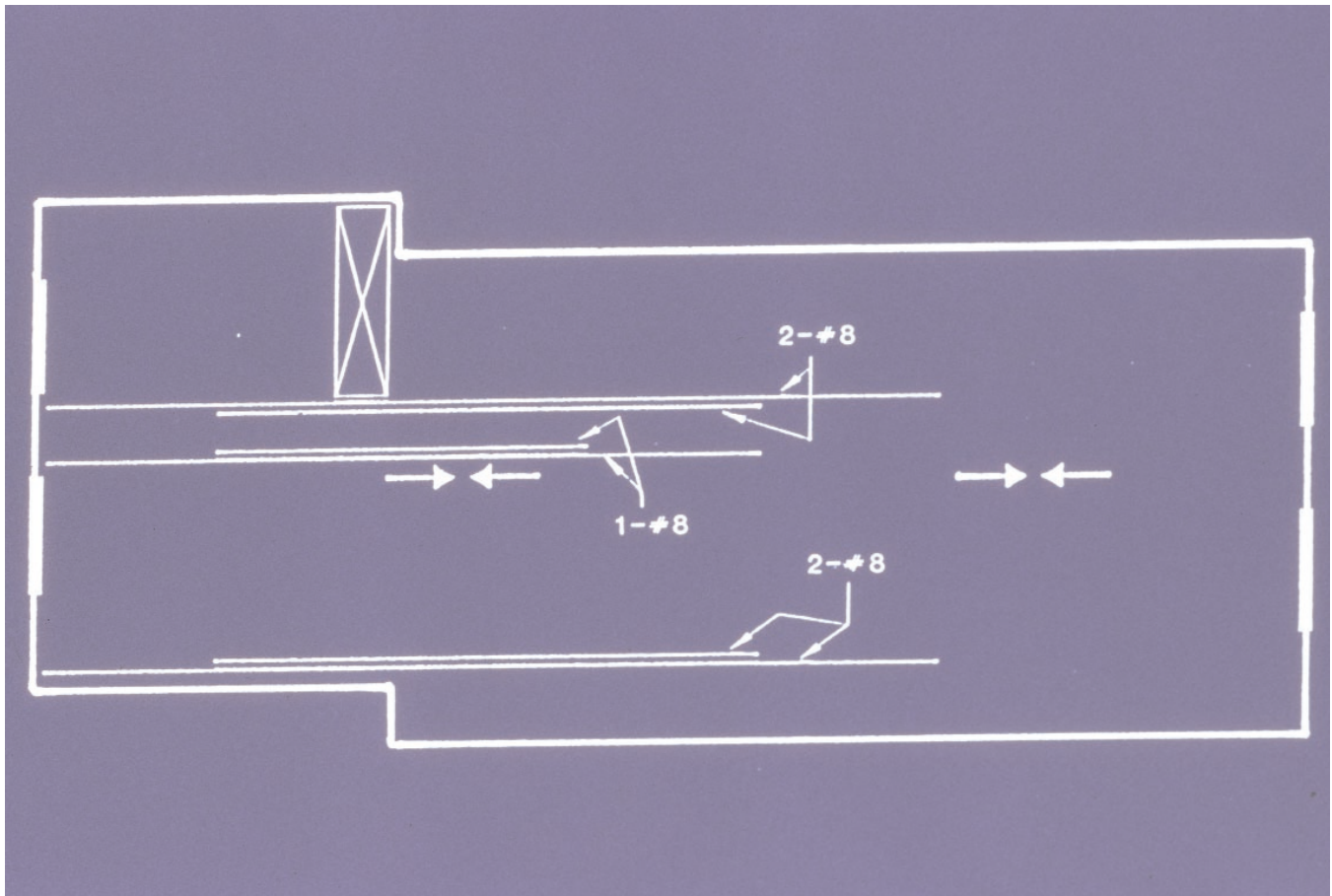

Remember from some of our earlier slides that the floor diaphragm transfers the seismic loads to the walls. When you have large openings you have to think through your design carefully to make sure the load path is continuous. Because of the presence of the stairway opening in this building, the designer specified additional rebar in the floor diaphragm. This plan view shows the additional rebar that the engineer indicated to complete the force or load transfer around the stair opening.

Slide #25



During the Loma Prieta earthquake a huge crack opened up in the floor diaphragm at the corner of the stair opening.

Slide #26



Upon investigation it turned out that the bars were never installed. There was no way to get the load to the walls at each end of the building. Ideally we need a system of checks and balances where if the contractor misses the placement of these bars the inspector catches it. Or even if the bars were missing on the shop drawings, the contractor should have asked why the engineer's plans and the rebar detailer's plans did not match.

Slide #27



Let's take a look at concrete block or masonry construction for a minute. In order to perform well in an earthquake, the masonry block and grout has to meet specified strengths and the rebar has to be placed in accordance with the drawings. Here we see what happens when construction workers are unclear on the concept of transferring the load. When finishing off the top of the wall, they closed off the top of the concrete block cell with paper, and then put concrete on top of the paper. The paper prevented a positive connection between the wall and the slab above; breaking the load path and resulting in this kind of damage.

Slide #28

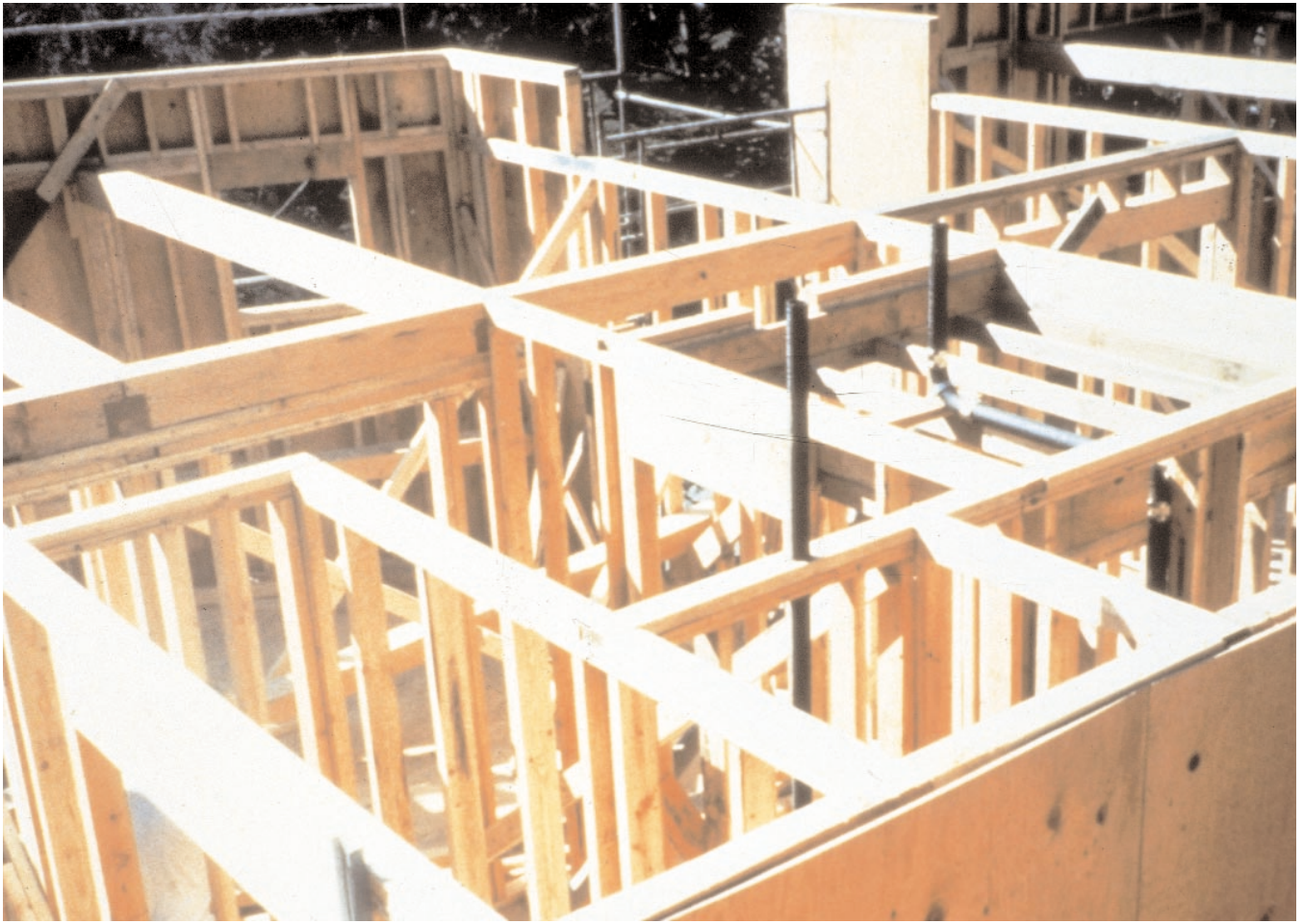

Let's move to the most widely used construction type—wood frame construction.

Slide #29



Plywood walls provide excellent earthquake resistance in earthquakes if they are installed properly. In order for a plywood wall to be effective, it relies on nails. These nails must be of the proper size, spacing, and with the proper edge distance. They cannot be overdriven, or the plywood will lose its strength.

Slide #30



In Big Bear, California, after the 1992 earthquake there, we saw tremendous damage in modern wood frame construction, caused by construction and inspection errors. Here we can see damage caused by nails that were overdriven or placed wrong. In addition, the vertical edge nails were missing. The plywood just peeled off, unable to transfer the load.

Slide #31



Here's a brand new beautiful house in Big Bear that suffered significant expensive, but unnecessary, damage in that earthquake. Unnecessary because the carpenters were unclear on the concept of a load path and installed the plywood only from the first floor up.

Slide #32



They put no plywood on the cripple wall between the foundation and the first floor. This critical portion of the house receives the earthquake loads from all the walls, floors, and roof. Earthquake forces exerted on a building accumulate in the lower portions of a structure, making the cripple wall construction critical. It receives the highest demand and must transfer the loads to the foundation. It was unable to do so in this case, due to the lack of plywood.

Slide #33



Here is another brand new big house in the same earthquake, two stories, knocked off its foundation.

Slide #34



In this house, wood panels serve both as the structural sheathing and as siding. Carpenters had not properly nailed the wood siding panels on the cripple wall. So here, while the load path appears to be more complete than in the previous example, incomplete nailing of the edges of the siding resulted in this damage.

Slide #35



Without this nailing, the load cannot be transferred from the building down into the ground.

Slide #36



In a retrofit situation, as in new construction, all the parts are important to the good performance of the building. Here a homeowner hired a contractor to retrofit a wood frame home. But the contractor clearly didn't understand force transfer. The contractor installed a beautiful plywood wall, but in order to complete the load path and transfer the force to the shear wall from the floor above you need blocking in each space between the floor joists. The blocking provides a nailing surface for nails from the floor and for sheet metal clips needed to connect the wall top plate to the blocking.

Slide #37

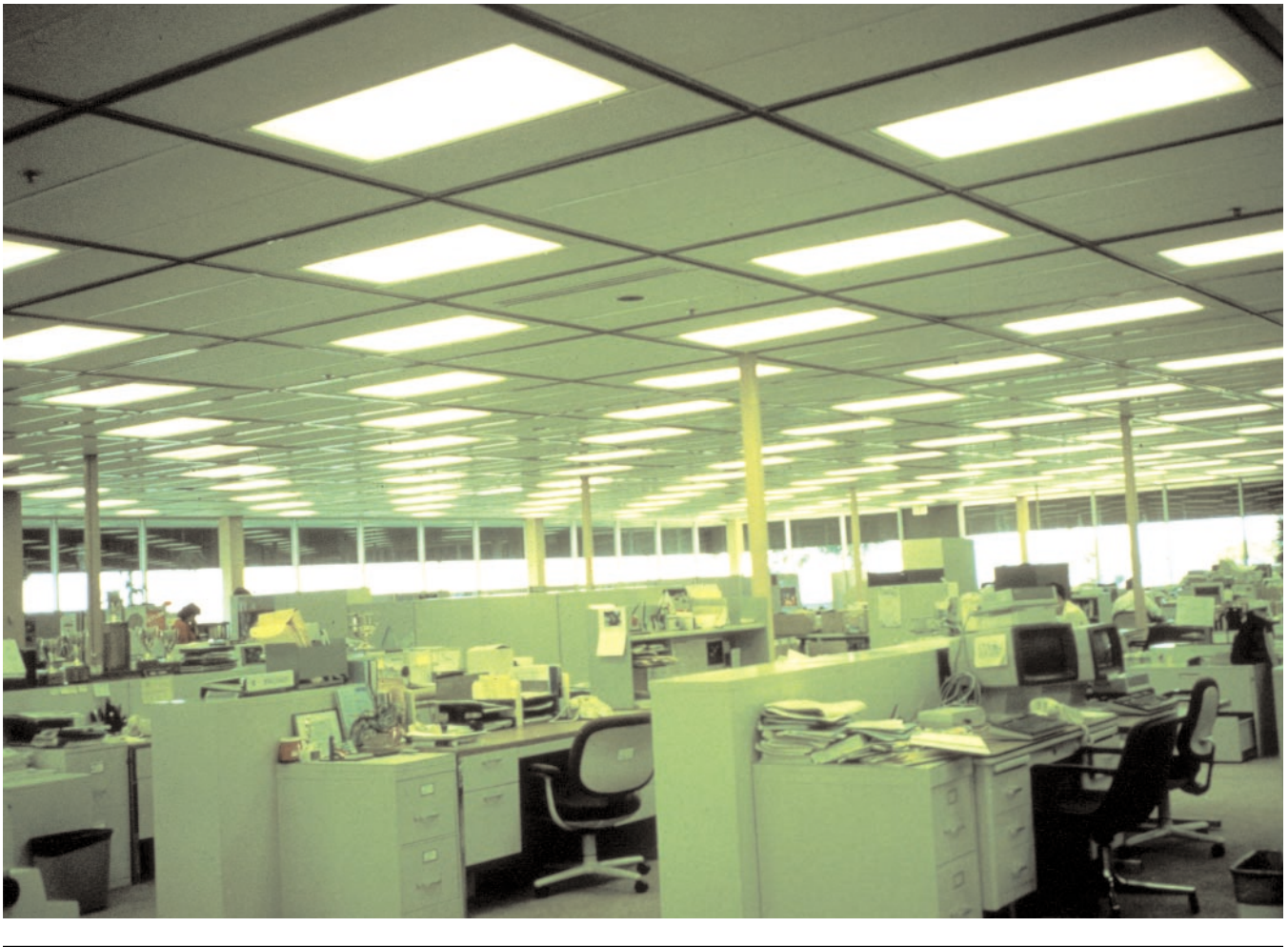

Now let's turn our attention to non-structural elements. We actually find that after every earthquake the costs associated with non-structural damage are higher than the costs of structural damage. Non-structural elements definitely warrant our attention. They can mean the difference between continuing operation after an earthquake or not.

Slide #38



This is the fellow we rely on to make sure our non-structural elements such as the ceiling grid perform well. He has to work with little documentation or guidelines for proper installation and maintenance. Often the proper bracing for non-structural elements is not even shown on drawings, and it's left up to this fellow to do it correctly.

Slide #39

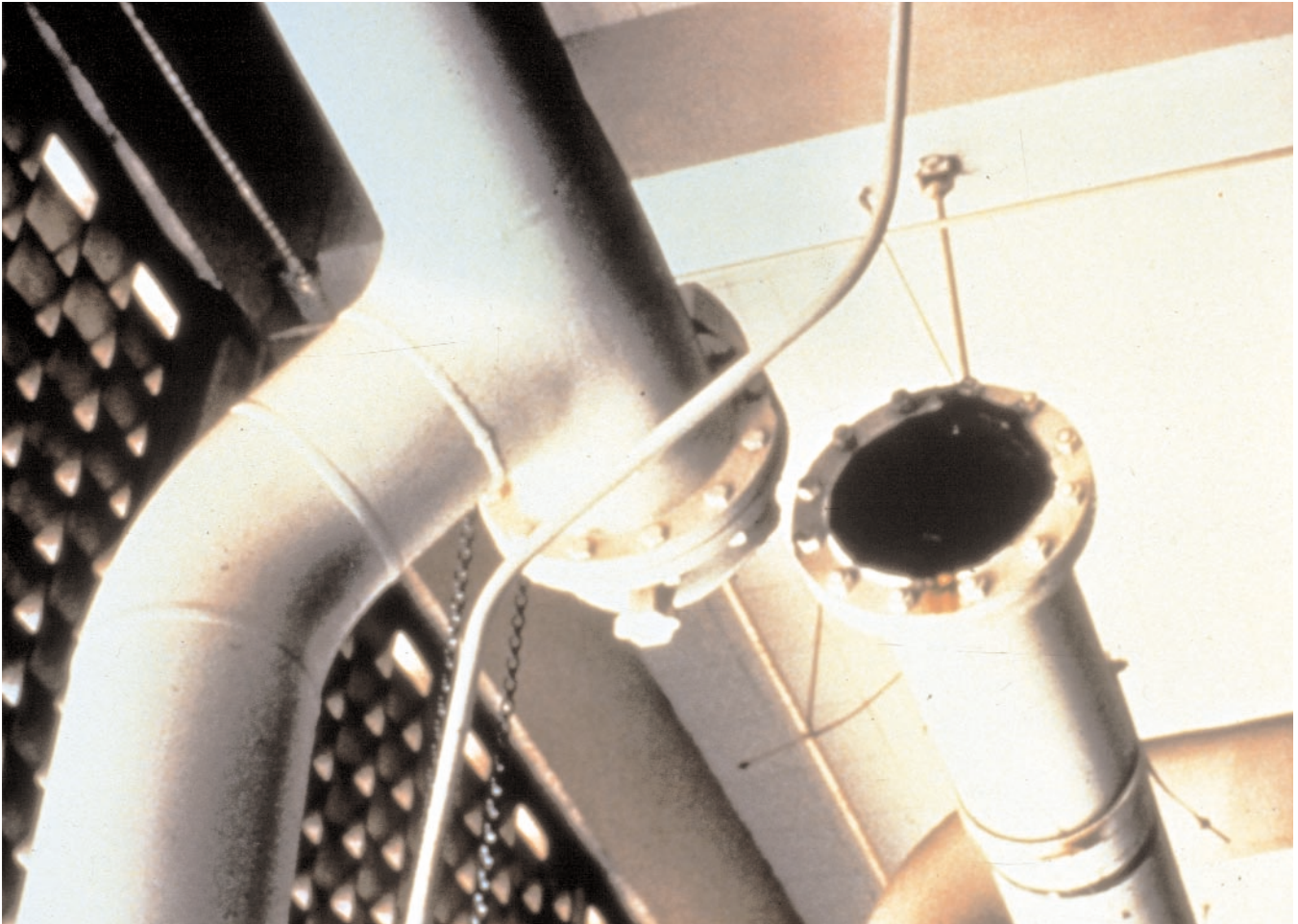

Breaks or leaks in water pipes cause some of the most devastating damage that we see. These pipes need to be properly braced to limit their movement or isolate them from earthquake forces.

Slide #40



After the Northridge earthquake this brand new hospital was closed and evacuated, with millions of dollars in non-structural damage. These hospitals are supposed to be designed, inspected and built according to the highest standards, but even in a brand new hospital you can find flagrant violations in terms of the protection of non-structural systems.

Slide #41



There were many leaks caused by breaks of the reheat coils—to limit the release of water they need flexible couplings where the waterlines connect. Imagine what happens to the furnishings and equipment below this leak.

Slide #42



Here we see an overhead tank on a trapeze suspended from the structure above. The piping coming out of the tank feeds a piece of equipment below. Neither the tank nor its trapeze is braced, so in an earthquake it will swing. This motion will cause the piping or its connectors to break. In this case, the installer and inspector both should have known better.

Slide #43

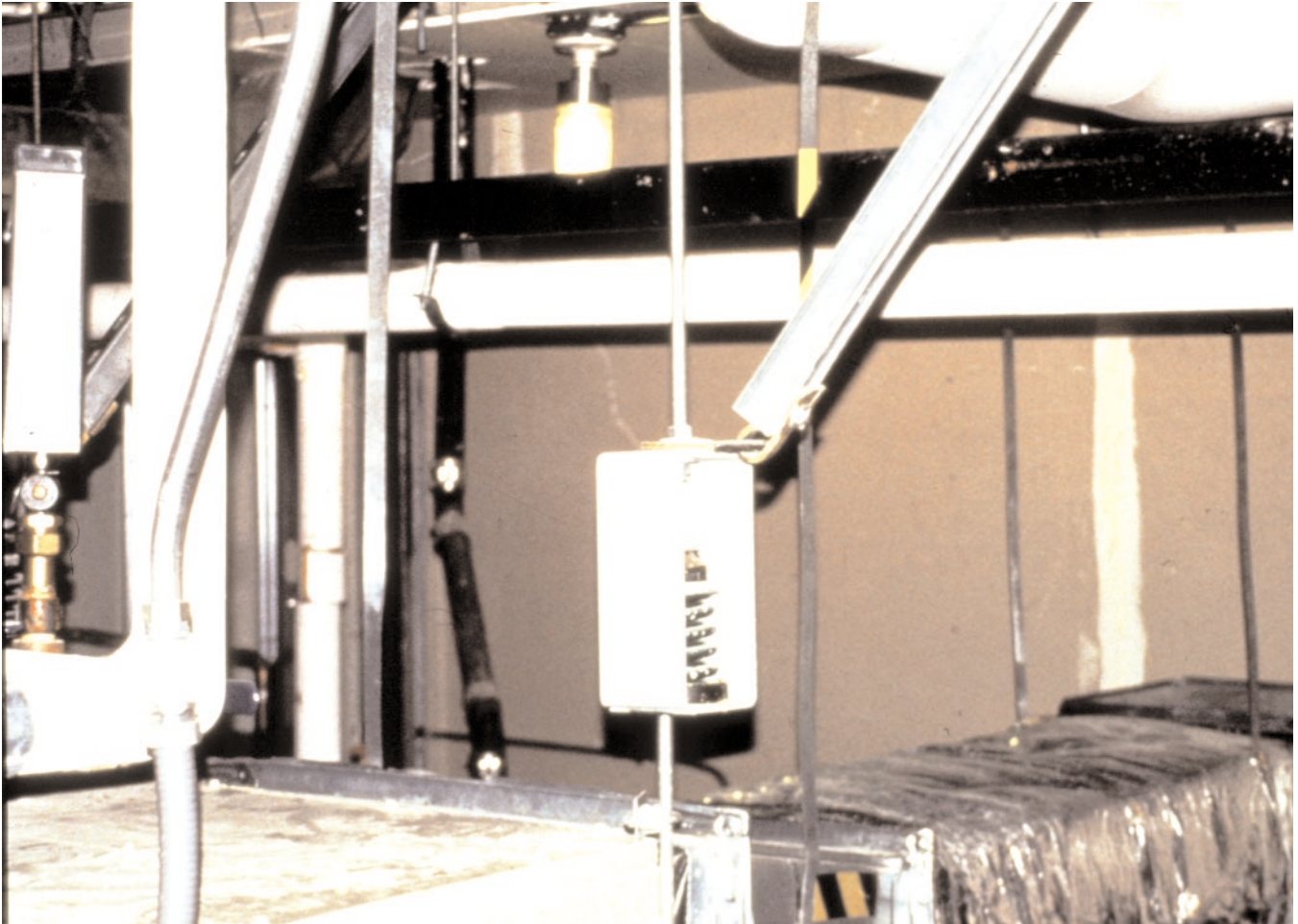

This box with the black spring in it is an isolator for a fan that is located in a duct. The isolator has a diagonal brace, which must have been intended for the fan itself. The isolator does not need bracing, but the in-line fan certainly does. Whoever installed and inspected the unit had no clue about the importance of bracing and its role in promoting proper performance in an earthquake.

Slide #44

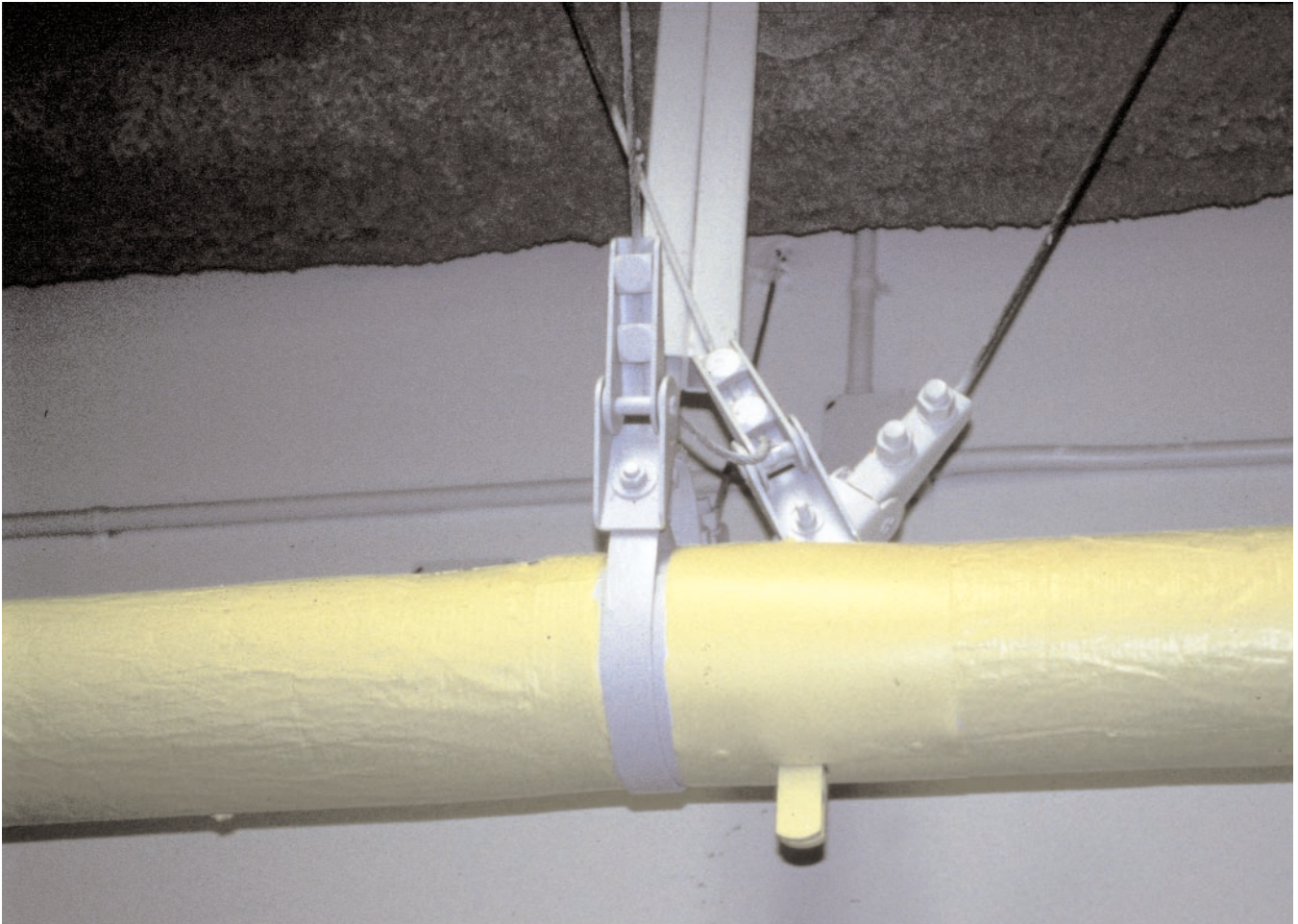

This slide shows wires providing longitudinal bracing for a pipe. The wires are connected to a ring clamp that is inside the insulation connected directly to the pipe, and should prevent longitudinal movement of the pipe.

Slide #45

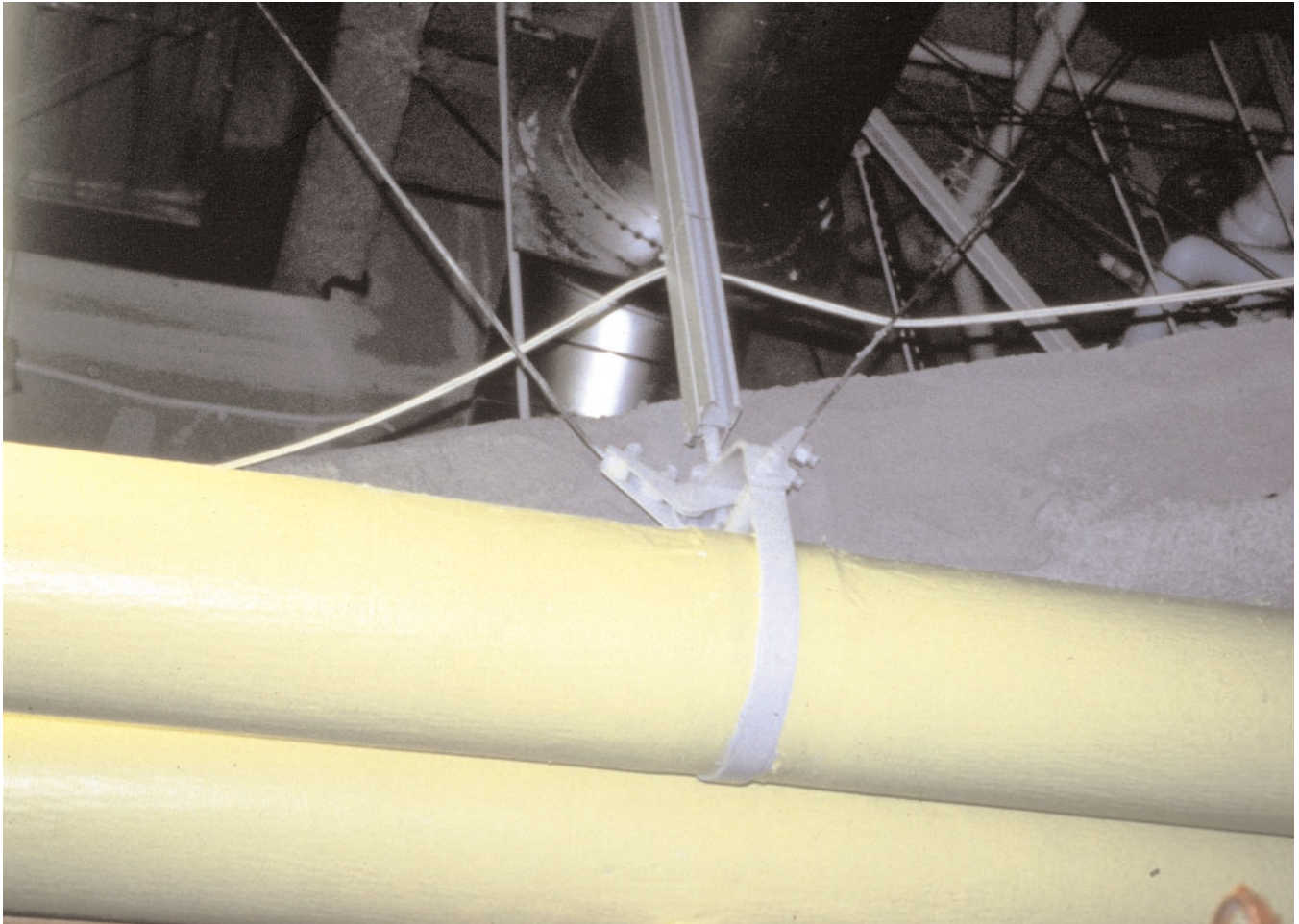

Here is a pipe where the longitudinal bracing is attached to only the hanger. The pipe can slide within the hanger because there is no direct connection between the bracing and the pipe. Unless the piping has flexible joint fittings, movement can cause breakage and leaking.

Slide #46



This is a motor control center in a hospital mechanical room. It is a narrow, top heavy piece of equipment. It is anchored at the bottom, but also needs to be anchored at the top so that it will not tip over. If it tips or shifts too much, the equipment it controls will fail, possibly making the building uninhabitable.

Slide #47