

# Masoneilan\* **12400** Series Level Transmitter/Controller

Instruction Manual & Safety Guide (Rev.B)



**BAKER  
HUGHES**  
a GE company



THESE INSTRUCTIONS PROVIDE THE CUSTOMER/OPERATOR WITH IMPORTANT PROJECT-SPECIFIC REFERENCE INFORMATION IN ADDITION TO THE CUSTOMER/OPERATOR'S NORMAL OPERATION AND MAINTENANCE PROCEDURES. SINCE OPERATION AND MAINTENANCE PHILOSOPHIES VARY, BHGE (BAKER HUGHES, A GE COMPANY AND ITS SUBSIDIARIES AND AFFILIATES) DOES NOT ATTEMPT TO DICTATE SPECIFIC PROCEDURES, BUT TO PROVIDE BASIC LIMITATIONS AND REQUIREMENTS CREATED BY THE TYPE OF EQUIPMENT PROVIDED.

THESE INSTRUCTIONS ASSUME THAT OPERATORS ALREADY HAVE A GENERAL UNDERSTANDING OF THE REQUIREMENTS FOR SAFE OPERATION OF MECHANICAL AND ELECTRICAL EQUIPMENT IN POTENTIALLY HAZARDOUS ENVIRONMENTS. THEREFORE, THESE INSTRUCTIONS SHOULD BE INTERPRETED AND APPLIED IN CONJUNCTION WITH THE SAFETY RULES AND REGULATIONS APPLICABLE AT THE SITE AND THE PARTICULAR REQUIREMENTS FOR OPERATION OF OTHER EQUIPMENT AT THE SITE.

THESE INSTRUCTIONS DO NOT PURPORT TO COVER ALL DETAILS OR VARIATIONS IN EQUIPMENT NOR TO PROVIDE FOR EVERY POSSIBLE CONTINGENCY TO BE MET IN CONNECTION WITH INSTALLATION, OPERATION OR MAINTENANCE. SHOULD FURTHER INFORMATION BE DESIRED OR SHOULD PARTICULAR PROBLEMS ARISE WHICH ARE NOT COVERED SUFFICIENTLY FOR THE CUSTOMER/OPERATOR'S PURPOSES THE MATTER SHOULD BE REFERRED TO BHGE.

THE RIGHTS, OBLIGATIONS AND LIABILITIES OF BHGE AND THE CUSTOMER/OPERATOR ARE STRICTLY LIMITED TO THOSE EXPRESSLY PROVIDED IN THE CONTRACT RELATING TO THE SUPPLY OF THE EQUIPMENT. NO ADDITIONAL REPRESENTATIONS OR WARRANTIES BY BHGE REGARDING THE EQUIPMENT OR ITS USE ARE GIVEN OR IMPLIED BY THE ISSUE OF THESE INSTRUCTIONS.

THESE INSTRUCTIONS CONTAIN PROPRIETARY INFORMATION OF GE, AND ARE FURNISHED TO THE CUSTOMER/OPERATOR SOLELY TO ASSIST IN THE INSTALLATION, TESTING, OPERATION, AND/OR MAINTENANCE OF THE EQUIPMENT DESCRIBED. THIS DOCUMENT SHALL NOT BE REPRODUCED IN WHOLE OR IN PART NOR SHALL ITS CONTENTS BE DISCLOSED TO ANY THIRD PARTY WITHOUT THE WRITTEN APPROVAL OF BHGE.

## Document Changes

**Revision A – 07/2014:** Add of SIL Section

**Revision B – 11/2017:**

- Section 2.2.6:  
Correction of typo error on ES-749 (instead of ES-479)
- Section 5.4.6:  
Add of this new section to answer requirements from Kazakhstan Metrology Pattern Approval
- Section 9.2.2:  
Add of remark that 12400 head with SIL design cannot be mounted on 12120/12800 Torque Tube due to the addition of bias block S/A.  
This is in line with CPPR 162999519.
- Section 10.7:  
Enhancements on Table Error and Warning Messages  
Add of column “Device Action (Warning message or Failsafe position).

# Table of Contents

<b>GENERAL</b> .....	<b>3</b>	<b>7.2. TRANSMITTER CONFIGURATION</b> .....	<b>24</b>
<b>SPARE PARTS</b> .....	<b>3</b>	<b>7.3. TRANSMITTER CALIBRATION</b> .....	<b>25</b>
<b>AFTER SALES SUPPORT</b> .....	<b>3</b>	7.3.1. OPERATING RULES AND CALIBRATION PRINCIPLE.....	26
<b>TRAINING</b> .....	<b>3</b>	7.3.2. CALIBRATION AT WORKSHOP WITH WEIGHTS .....	29
<b>1. DESCRIPTION - OPERATION</b> .....	<b>4</b>	7.3.3. CALIBRATION ON SITE WITH PROCESS FLUIDS .....	31
1.1. PRINCIPLE OF OPERATION .....	4	7.3.4. CALIBRATION WITH MECHANICAL STOPS .....	32
1.2. SIGNAL PROCESSING .....	4	<b>7.4. CALIBRATION OF SPECIFIC GRAVITY METER</b> .....	<b>34</b>
<b>2. PROTECTION STANDARDS</b> .....	<b>5</b>	<b>7.5. MECHANICAL STOPS SETTING</b> .....	<b>35</b>
2.1. ATEX / IECEx CERTIFICATIONS .....	5	<b>7.6. TORQUE TUBE TEMPERATURE COMPENSATION</b> .....	<b>37</b>
2.2. FM / FMC CERTIFICATIONS .....	6	<b>7.7. CONTROLLER FUNCTION (12410 MODEL ONLY)</b> .....	<b>39</b>
2.2.1. GENERAL REQUIREMENTS .....	6	<b>8. SAFETY MANUAL FOR SIL APPLICATIONS</b> .....	<b>45</b>
2.2.2. FLAMEPROOF AND DUST IGNITION PROOF REQUIREMENTS .....	6	<b>8.1. RELEVANT STANDARDS</b> .....	<b>45</b>
2.2.3. INTRINSICALLY SAFE REQUIREMENTS .....	6	<b>8.2. TERMS AND DEFINITIONS</b> .....	<b>45</b>
2.2.4. DESCRIPTION OF EXPLOSION PROOF AND INTRINSIC SAFETY		<b>8.3. SAFETY REQUIREMENTS</b> .....	<b>46</b>
MARKING.....	7	8.3.1. PROBABILITY OF FAILURES ON DEMAND (PFD) .....	46
2.2.5. REPAIR .....	8	8.3.2. SAFETY INTEGRITY OF THE HARDWARE.....	46
2.2.6. ES-749 INTRINSICALLY SAFE INSTALLATION WIRING		<b>8.4. SAFETY CHARACTERISTICS</b> .....	<b>46</b>
REQUIREMENTS.....	9	8.4.1. ASSUMPTIONS.....	46
2.2.7. NOTES FOR INTRINSICALLY SAFE INSTALLATION .....	10	8.4.2. SAFETY INTEGRITY OF THE HARDWARE .....	47
<b>3. MARKING – NUMBERING SYSTEM</b> .....	<b>12</b>	8.4.3. HARDWARE LOCK JUMPER ADJUSTMENT.....	47
<b>3.1. MARKING</b> .....	<b>12</b>	8.4.4. CHARACTERISTICS .....	47
<b>3.2. NUMBERING SYSTEM</b> .....	<b>12</b>	<b>8.5. SAFETY FUNCTION</b> .....	<b>48</b>
<b>4. INSTALLATION</b> .....	<b>13</b>	<b>8.6. PROOF TEST</b> .....	<b>48</b>
<b>4.1. STORAGE AND CONDITIONS AT DELIVERY</b> .....	<b>13</b>	<b>9. MAINTENANCE</b> .....	<b>49</b>
<b>4.2. MOUNTING ON SITE</b> .....	<b>13</b>	<b>9.1. REMOVAL OF 12400 CASE FROM TORQUE TUBE</b> .....	<b>49</b>
4.2.1. EXTERNAL MOUNTING .....	13	<b>9.2. INSTALLATION OF 12400 CASE ON A TORQUE TUBE</b> .....	<b>49</b>
4.2.2. INTERNAL MOUNTING .....	14	9.2.1. ON A 12200/300/400 SERIES TORQUE TUBE .....	49
<b>5. CASE DESCRIPTION</b> .....	<b>15</b>	9.2.2. ON A 12120 OR 12800 SERIES TORQUE TUBE.....	50
<b>5.1. ELECTRONIC COMPARTMENT</b> .....	<b>15</b>	<b>9.3. REMOVAL OF 12400 CASE AND TORQUE TUBE S/A</b> .....	<b>51</b>
<b>5.2. MECHANISM COMPARTMENT</b> .....	<b>15</b>	<b>9.4. MOUNTING OF DLT CASE AND TORQUE TUBE S/A</b> .....	<b>52</b>
<b>5.3. MTBF</b> .....	<b>15</b>	<b>9.5. REVERSE INSTRUMENT CASE MOUNTING POSITION VERSUS TO</b>	
<b>5.4. CONNECTION COMPARTMENT</b> .....	<b>15</b>	<b>DISPLACER POSITION (LEFT OR RIGHT)</b> .....	<b>53</b>
5.4.1. ELECTRIC CIRCUIT.....	15	<b>9.6. REPLACEMENT OF ELEC. AND MECH. COMPONENTS</b> .....	<b>53</b>
5.4.2. WIRING AND CONNECTIONS .....	16	<b>10 TROUBLE SHOOTING</b> .....	<b>54</b>
5.4.3. ALLOWABLE SUPPLY VOLTAGES.....	16	<b>10.1. NO SIGNAL</b> .....	<b>54</b>
5.4.4. MAXIMUM POWER .....	16	<b>10.2. EXISTING SIGNAL BUT NOTHING ON LCD DISPLAY</b> .....	<b>54</b>
5.4.5. OUTPUT SIGNAL AND LOAD RESISTANCE .....	16	<b>10.3. STEADY SIGNAL, NO CHANGE WHEN LEVEL VARIES</b> .....	<b>54</b>
<b>6. OPERATING THE INSTRUMENT</b> .....	<b>19</b>	<b>10.4. OUTPUT SIGNAL DIFFERS FROM VALUE DISPLAYED ON LCD</b> .....	<b>54</b>
<b>6.1. GENERAL PRINCIPLES</b> .....	<b>19</b>	<b>10.5. NO HART® COMMUNICATION</b> .....	<b>55</b>
6.1.1. THE LIQUID CRYSTAL DISPLAY (LCD).....	19	<b>10.6. OUTPUT SIGNAL DOES NOT MATCH WITH THE LIQUID LEVEL</b>	
6.1.2. PUSHBUTTONS .....	19	<b>(LINEARITY ISSUE)</b> .....	<b>55</b>
6.1.3. OPERATING MODES.....	19	<b>10.7. VIEW ERROR DIAGNOSTICS MESSAGES</b> .....	<b>56</b>
6.1.4. PUSHBUTTONS MENUS DESCRIPTION .....	20	<b>Appendix A – NORMAL Menu / SETUP Menu</b> .....	<b>61 to 62</b>
<b>7. COMMISSIONING</b> .....	<b>22</b>	<b>Appendix B – BASIC SETUP Menu</b> .....	<b>63 to 65</b>
<b>7.1. INSTRUMENT COUPLING TO THE TORQUE TUBE</b> .....	<b>22</b>	<b>Appendix C – ADVANCED SETUP Menu</b> .....	<b>66 to 69</b>
		<b>Appendix D – ENGINEERING UNIT Menu</b> .....	<b>70 to 72</b>
		<b>Appendix E – 4-20mA GENERATOR Menu</b> .....	<b>73 to 74</b>
		<b>Appendix F – VIEW DATA Menu</b> .....	<b>75 to 76</b>
		<b>Appendix G – FAILSAFE / VIEW ERROR Menus</b> .....	<b>77 to 78</b>

Use of **DANGER, WARNING, CAUTION, and NOTE.**

These instructions contain **DANGER, WARNING, CAUTION, and NOTE** where necessary to alert you to safety related or other important information.

**DANGER** - Hazards which result in severe personal injury or death.

**WARNING** - Hazards which could result in personal injury.

**CAUTION** - Hazards which could result in equipment or property damage.

**NOTE** - Alerts you to pertinent facts and conditions.

Although **DANGER** and **WARNING** hazards are related to personal injury, and the **CAUTION** hazards involve equipment or property damage, it should be understood that operation of damaged equipment could, under certain operational conditions, result in degraded process system performance which may lead to personal injury or death. Therefore, comply fully with all **DANGER, WARNING, and CAUTION** notices.

## IMPORTANT: SAFETY WARNING

Read these instructions carefully **BEFORE** this instrument is installed or maintained.

Products certified for use in explosion proof (flameproof) or intrinsically safe installations **MUST**:

- a) Be installed in accordance with EN/IEC 60079-14, EN/IEC 61241-14, EN/IEC 60079-17 standards and/or local and national codes for hazardous area installations.
- b) Only be used in situations which comply with the certification conditions stated in this manual and those stated in GEA19100 (400152322) ATEX Instruction Manual.
- c) Only be maintained by qualified personnel with adequate training on hazardous area instrumentation (see Instruction Manual GEA19100 - 400152322). Taking the appropriate actions to ensure that site personnel who are performing installation, commissioning and maintenance have been trained in proper site procedures for working with and around equipment, per Safe Site Work Practices, are the end user's responsibility.

It is the end user's responsibility to:

- Verify material compatibility with the application
- Ensure proper use of fall protection when working at heights, per Safe Site Work Practices
- Ensure use of proper Personal Protective Equipment
- Take the appropriate actions to ensure that site personnel who are performing installation, commissioning and maintenance have been trained in proper site procedures for working with and around equipment, per Safe Site Work Practices

Non-compliance with the rules and cautionary notes of this instruction may cause malfunction of the device or serious damage to it, personnel or the surrounding equipment or site. Not intended for use in life support systems.

Items sold by BHGE are warranted to be free from defects in material and workmanship for a period of one year from the date of first use or eighteen (18) months from the date of delivery, whichever occurs first, provided such items are used according to all relevant recommendations and instructions from BHGE.

**BHGE reserves the right to discontinue manufacture of any product or change product materials, design, or specifications without notice.**

### General

This manual provides installation, operation and maintenance instructions for the Masoneilan 12400 Series Digital Level Transmitter/Controller from BHGE. It also includes a complete parts reference and a list of recommended spare parts.

### Spare Parts

When performing maintenance, use BHGE's Masoneilan spare parts only. Parts can be obtained through your local Masoneilan products representative or the Spare Parts Department. When ordering parts, always include the Model and Serial Number of the unit being repaired.

### After Market Support

BHGE offers aftermarket support for Masoneilan valves and instruments start-up, maintenance, and repair. Contact the nearest BHGE Sales Office or Representative or After Sales Department.

### Training

Regularly scheduled classes are conducted at Masoneilan facilities for training customer service and instrumentation personnel in the operation, maintenance, and application of control valves and instruments. Arrangements for these classes can be made through your local Masoneilan products sales contact.

# 1. Description - Operation

The 12400 Series Digital Level Transmitter/Controller is a high performance, easy-to-set instrument based on a modular design that permits quick, low-cost upgrades as new features are developed and as your needs change.

## 1.1. PRINCIPLE OF OPERATION

The Masoneilan 12400 Series instrument a 2-wire, loop powered, digital displacement level transmitter/controller with HART® communication that uses field proven buoyancy and torque tube principles.

A change in liquid level varies the apparent weight of the displacer (130), which increases or decreases load on the torque tube (136) by an amount directly proportional to the change in liquid level. The resulting rotation of the torque rod (138), seen in Figure 1, modifies the magnetic field of a frictionless, non-contacting sensor (40). The signal generated by the sensor varies current in the loop in proportion to the level in the vessel.

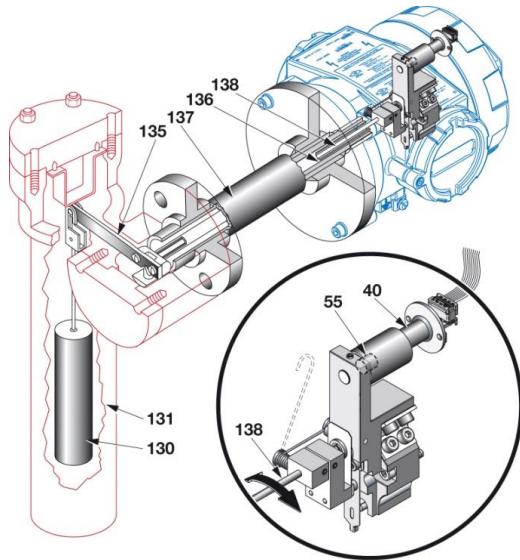

Figure 1 – Diagram of principle

PARTS REFERENCES			
40	Non contact Sensor	135	Torque arm
55	Magnet	136	Torque tube
130	Displacer	137	Torque tube housing
131	Displacer chamber	138	Torque rod

## 1.2 SIGNAL PROCESSING

The sensor analog signal is converted into an error-free digital signal for processing by the on board micro-controller. After signal processing, the digital result is converted to analog output signals for use by configuration and options.

### Transmitter model:

- ◆ The 4-20 mA analog output signal, available on the AO\_1 terminal, is the level or interface measurement signal with HART® communication.

### Transmitter model with two (2) adjustable switches and second 4-20mA analog output:

- ◆ The two 4-20 mA analog output signals, available on the AO\_1 and AO\_2 terminals, are the level or interface measurement signal, with HART communication (AO\_1 only).
- ◆ DO\_1 and DO\_2 terminals are two independent isolated digital switch outputs. They are user-adjustable and polarity sensitive.

### Controller model with two (2) adjustable switches and second 4-20mA analog output:

- ◆ The 4-20 mA analog output signal, available on AO\_1 terminals, is the controller output signal generated by a PID algorithm based on error between the local setpoint and the level process variable. HART communication is available on AO\_1.
- ◆ The 4-20 mA analog output signal, available on the AO\_2 terminals, is the level or interface measurement signal. No HART communication.
- ◆ DO\_1 and DO\_2 terminals are two independent isolated digital switch outputs. They are user-adjustable and polarity sensitive.

## IMPORTANT

Options described above are operable only if they have been ordered initially. You cannot add them later on site (see numbering system Section 3.2).

The 12400 instrument enables retrofit of existing pneumatic or digital level instruments (see Section 9.2).

## 2. Protection standards

Installation in a hazardous atmosphere must be performed in accordance with the requirements specified in the applicable standard for protection against explosion.

### WARNING:

IMPROPER REPLACEMENT OR SUBSTITUTION OF ELECTRONIC COMPONENTS OR OF CERTAIN PARTS WHOSE CHARACTERISTICS DO NOT MEET REQUIREMENTS OF THE APPLICABLE STANDARDS FOR EXPLOSION PROTECTION MAY VOID THIS PROTECTION.

### 2.1. ATEX / IECEx CERTIFICATIONS

The 12400 Series Level Transmitter / Controller complies with the essential requirements of ATEX 94/9/EC European directive. This instrument is certified for use in explosion proof (flameproof) or intrinsically safe installations with dust or gas from groups IIA, IIB and IIC:

- Category II 1 GD – zones 0, 1, 2, 20, 21 and 22 for protection mode "ia"
- Category II 2 GD – zones 1, 2, 21 and 22 for protection mode "d".

The instrument also complies with the essential requirements of the modified EMC 2004/108/EC European directive for use industrial environment.

It is the end user's responsibility to ensure that products certified as **explosion proof** equipment or for use in **intrinsically safe** installations MUST BE:

- a) Installed, put into service, used and maintained in compliance with European and/or national and local regulations and in accordance with the recommendations contained in the relevant standards concerning potentially explosive atmospheres.
- b) Used only in situations which comply with the certification conditions shown in this document and after verification of their compatibility with the zone of intended use and the permitted maximum ambient temperature.
- c) **Installed and maintained only by personnel who have been trained and certified in installation, commissioning and maintenance in proper site procedures for working with and around equipment, per Safe Site Work Practices.**

Under certain operating conditions, use of a damaged instrument could cause a degradation of the performance of the system, which may lead to personal injury or death, damage to the equipment and or other equipment, as well as the site.

**Use only genuine replacement parts, provided by the manufacturer, to guarantee that the products comply with the essential European Directives safety requirements mentioned above.**

**All actions related to installation, site commissioning and maintenance must be performed in accordance with instructions provided in the ATEX instruction manual GEA19100 (400152322).**

## 2.2. FM / FMc CERTIFICATIONS

### 2.2.1. GENERAL REQUIREMENTS

#### **! WARNING !**

Failure to adhere to the requirements listed in this manual may cause loss of life and property.

Installation and maintenance must be performed only by qualified personnel. Area Classification, Protection Type, Temperature Class, Gas Group, and Ingress protection must conform to the data indicated on the label.

Wiring and conduit must conform to all local and national codes governing the installation. Wiring must be rated for at least 5°C above the highest expected ambient temperature.

Approved wire seals against ingress of water and dust are required and the NPT fittings must be sealed with tape or thread sealant in order to meet the highest level of ingress protection.

Where the protection type depends on wiring glands, the glands must be certified for the type of protection required.

The metal housing is in a standard die-casting alloy which is predominately aluminum. The housing can be stainless steel also.

Before powering the 12400:

1. Verify that the electronic cover screws are tightened. This maintains the ingress protection level and the integrity of the flameproof enclosure.
2. If the Installation is Intrinsically Safe, check that the proper barriers are installed and the field wiring meets local and national codes for an IS installation. Never install a device which was previously installed without an intrinsically safe barrier in an intrinsically safe system.
3. If the Installation is Non-Incendive, check that all the wiring meets local and national codes.
4. Verify that the markings on the label are consistent with the application.

### 2.2.2. FLAMEPROOF AND DUST IGNITION PROOF REQUIREMENTS

The ½" NPT fittings must enter the housing at least five full turns.

Conduit seals are required within 18" of the conduit for flameproof installation.

### 2.2.3. INTRINSICALLY SAFE REQUIREMENTS

Wiring must be in accordance with ES-749 (see Section 2.2.6) and must conform to national and local standards for intrinsically safe installation.



## 2.2.4. DESCRIPTION OF EXPLOSION PROOF AND INTRINSIC SAFETY MARKING

The label may not appear exactly as shown, but must contain the information listed below. Additional information NOT pertaining to FM approval is allowed on the label.

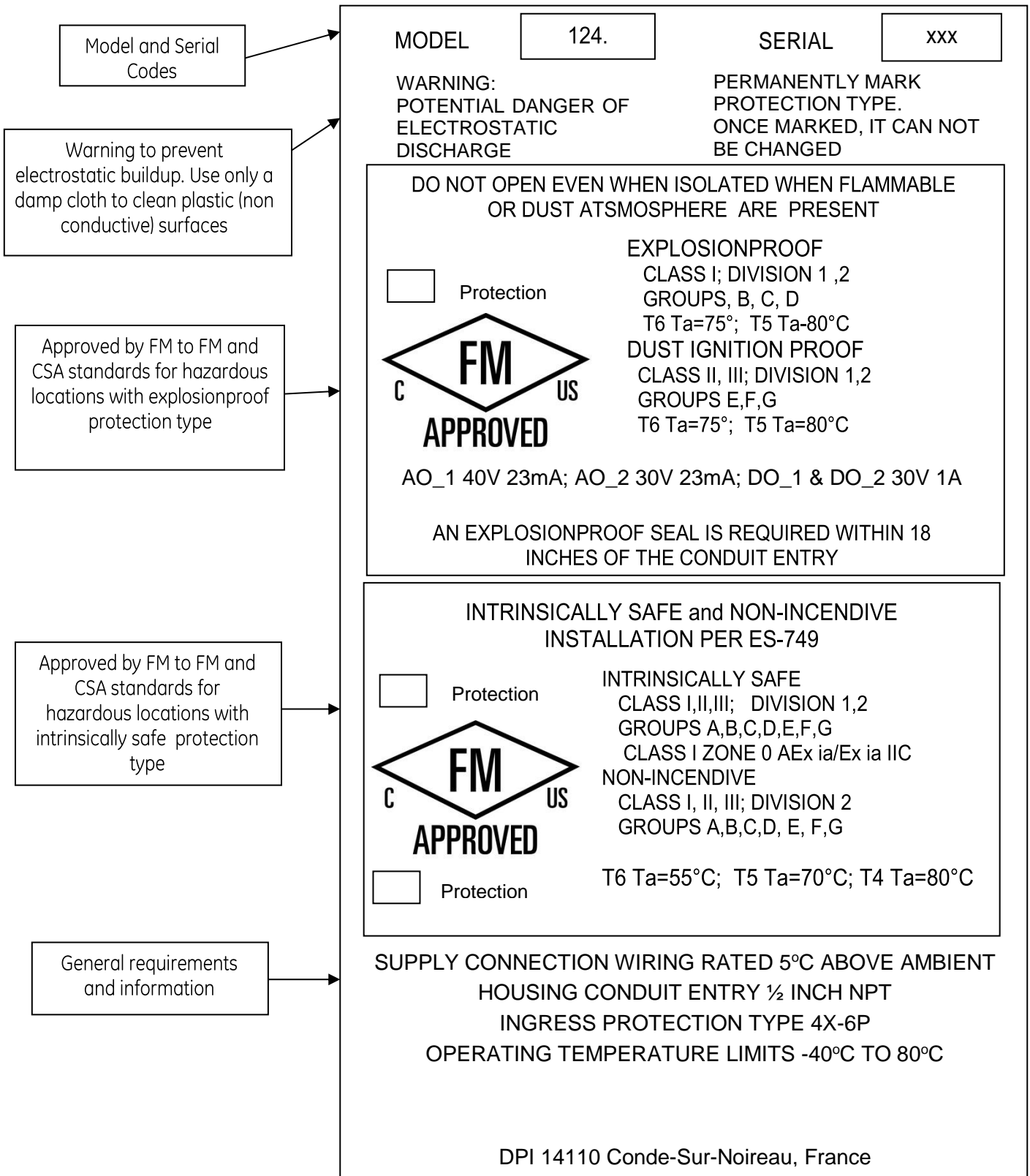

## 2.2.5. REPAIR

WARNING: EXPLOSION HAZARD – SUBSTITUTION OF COMPONENTS MAY IMPAIR SUITABILITY FOR USE AND CAUSE DAMAGE TO PERSONNEL, THE EQUIPMENT, OTHER EQUIPMENT AND THE SITE IN A HAZARDOUS LOCATION.

Only qualified service personnel are permitted to make repairs.

Replace ONLY with genuine Masoneilan parts from BHGE.

Only Masoneilan parts are permitted. This includes not only the major assemblies but also mounting screws and “O” rings. No substitutions with non-Masoneilan parts are permitted.

The following summary assures the safe operation of the 12400.

For ambient temperature greater than 70 °C, the user must choose a cable entry and a cable compatible with:

Ambient Temperature	Cable Temperature
75 °C	80 °C
80 °C	85 °C

The cable entry and the cable must be compatible with the minimum temperature of -40 °C as indicated on the marking plate.

The cable entry must have an ingress protection level at least equal to type 4X – 6P.

The joints (three pushbuttons, covers thread and O-ring) are greased with one of the following acceptable greases:

Grease Type	Manufacturer
GRAPHENE 702	ORAPI
MOLYKOTE111 COMPOUND	MOLYKOTE®
MULTILUB	MOLYKOTE®
GRIPCOTT NF	MOLYDAL

It is the user’s responsibility to check the gaskets once a year and in the event of damage to replace the defective parts with manufacturer’s replacement parts only.

For use in dusty hazardous areas, the user must maintain the enclosure to avoid the deposits of dusts, the maximum thickness must be <5 mm. For safe operation, this can be done only if the local conditions around the device are free of potentially explosive atmosphere.

The user must check the temperature increase on the 12400 head coming from the mechanical part in contact with the 12400 housing or through the process thermal radiation and ensure it is less or equal than the temperature classification allowed. This must be done in conformance with EN/IEC 60079-14 and / or national and local regulations applicable for explosive atmospheres.

The user may clean the device, mainly the plastic label, with a wet rag to avoid any electrostatic spark. For safe operation, this can be done only if the local conditions around the device are free of potentially explosive atmosphere.

## 2.2.6. ES-749 INTRINSICALLY SAFE INSTALLATION WIRING REQUIREMENTS

Each intrinsically safe cable must include a grounded shield or be run in a separate metal conduit.

**NON-HAZARDOUS LOCATION - UNSPECIFIED EXCEPT THAT BARRIERS MUST NOT BE SUPPLIED FROM NOR CONTAIN UNDER NORMAL OR ABNORMAL CONDITIONS A SOURCE OF POTENTIAL WITH RESPECT TO EARTH IN EXCESS OF 250 VOLTS RMS OR 250 VOLTS DC.**

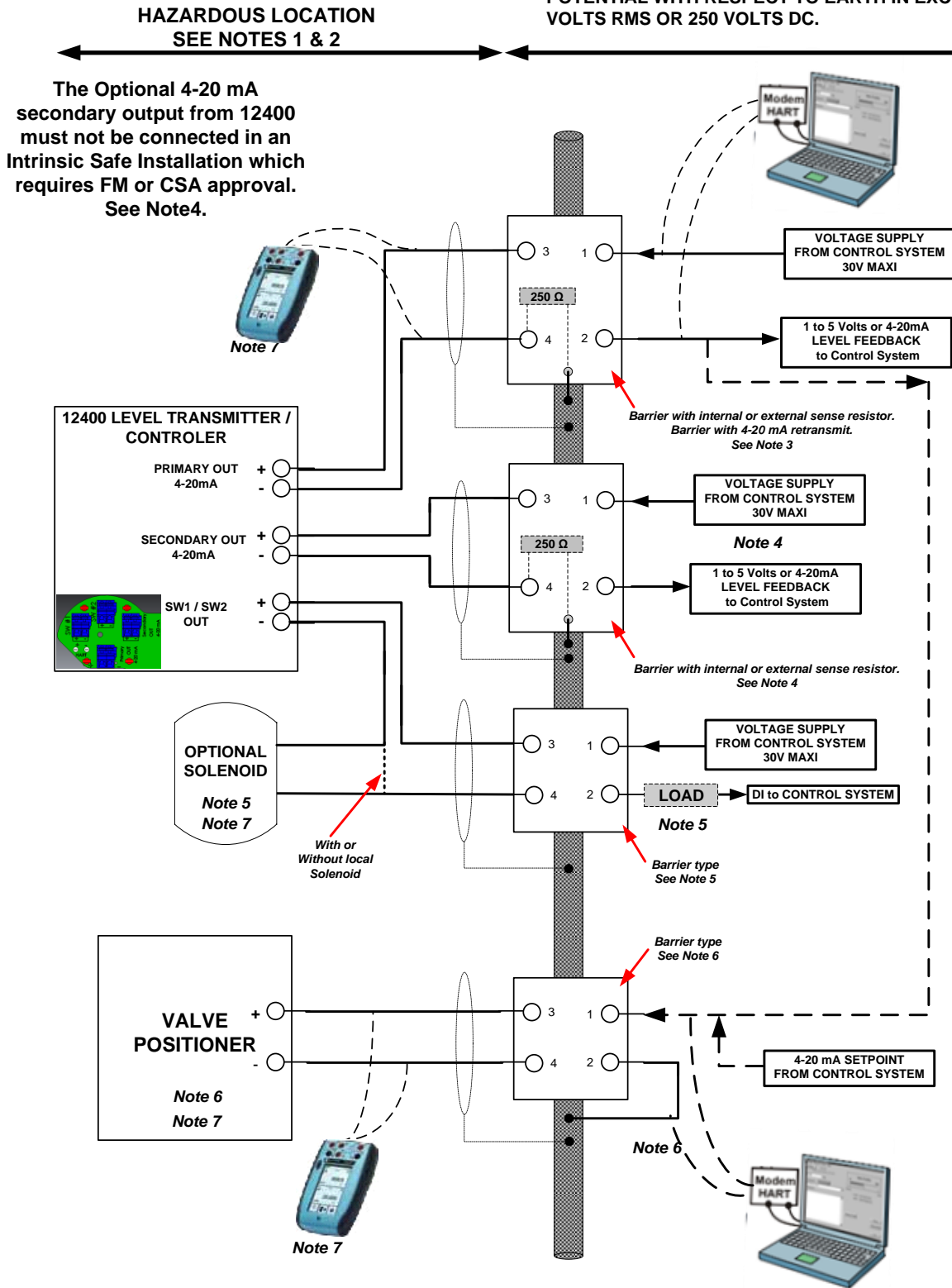

## 2.2.7. NOTES FOR INTRINSICALLY SAFE INSTALLATION

### **Note 1: HAZARDOUS LOCATION**

Refer to the device label for the description of the environment in which the device may be installed.

For Div 1 areas the barriers are always required. For Div 2 areas the barriers are not required as long as Div 2 wiring practices comply with the local electrical code and the supply voltages are normally less than 30 Volts.

### **Note 2: FIELD WIRING**

Intrinsically Safe wiring must be made with grounded shielded cable or installed in grounded metal conduit. The electrical circuit in the hazardous area must be capable of withstanding an A.C. test voltage of 500 Volts R.M.S. to earth or frame of the apparatus for one minute. Installation must be in accordance with BHGE's guidelines. The installation including the barrier earthing requirements must comply with the installation requirements of the country of use.

Factory Mutual requirements (USA): ANSI/ISA RP12.6 (Installation of Intrinsically Safe Systems for Hazardous (Classified) Locations) and the National Electrical Code, ANSI/NFPA 70. Division 2 installations must be installed per the National Electrical Code, ANSI/NFPA 70. See also, note 4.

CSA requirements (Canada): Canadian Electrical Code Part 1. Division 2 installations must be installed per the Canadian Electrical Code Division 2 Wiring Methods. See also note 4.

### **Note 3: PRIMARY OUT (+) and (-) 4-20 mA Terminals**

These terminals are the main loop power of the 12400 and provide a 4 to 20mA signal related to the level measurement or the embedded controller output for level control process. A transmitter type barrier with 250 Ohm series resistance (internal or external) is used for this connection; for example, MTL 788 or 788R. For controller application, an active barrier with 4-20mA retransmit can be used to drive a valve positioner.

Entity Parameters:  $V_{max}=30$  VDC;  $I_{max}=125$  mA;  $C_i=2$  nF;  $L_i=500$   $\mu$ H;  $P_{max}=900$  mW

### **Note 4: SECONDARY OUT (+) and (-) 4-20 mA Terminals**

These terminals provide an additional 4 to 20 mA signal related to the level measurement. Use a transmitter type barrier with 250 Ohm series resistance (internal or external) for this connection; for example, MTL 788 or 788R.

Entity Parameters:  $V_{max}=30$  VDC;  $I_{max}=125$  mA;  $C_i=9$  nF;  $L_i=500$   $\mu$ H;  $P_{max}=900$  mW.

**NOTE:** The secondary out must not be connected in an Intrinsic Safe installation which requires FM or CSA approval.

### **Note 5: SW1 & 2 (+) and (-) Terminals**

There are two independent isolated solid state switch contact outputs on the 12400. They are labelled SW#1 and SW#2. The switches are polarity sensitive – that is, conventional current flows into the plus terminal. Examples of suitable barriers are MTL 707, MTL 787 and MTL 787S.

Entity parameters are:  $V_{max}=30$  VDC;  $I_{max}=125$  mA;  $C_i=4.5$  nF;  $L_i=10$   $\mu$ H;  $P_{max}=900$  mW.

### **Note 6: Controller mode**

The barrier is a Controller Output Type; for example, MTL 728. This barrier can be driven by an active barrier with 4-20mA retransmit or by the control system.

Entity Parameters: The optional device may be an I/P type 8000 series or a valve positioner type SVI II AP.

### **Note 7: Entity Requirement**

Cable capacitance and inductance plus the I.S. apparatus unprotected capacitance ( $C_i$ ) and inductance ( $L_i$ ) must not exceed the allowed capacitance ( $C_a$ ) and inductance ( $L_a$ ) indicated on the associated apparatus. If the optional HART® handheld Communicator (type DPI 620) is used on the Hazardous Area side of the barrier, then the capacity and inductance of the communicator must be added and the communicator must be agency approved for use in the hazardous area. Also, the current output of the Hand Held Communicator must be included in the current output of the associated equipment.

**Note 8: Barrier type**

The barriers may be active or passive and from any certified manufacturer for FMRC and CSA as long as the barriers comply with the listed entity parameters.

**Note 9: Use in dust atmosphere**

Dust-tight conduit seal must be used when installed in dust hazard environments.

**Note 10: Multiple protection approvals**

A device which has previously been installed without an approved IS barrier must NEVER be used subsequently in an intrinsically safe system. Installing the device without a barrier can permanently damage the safety related components in the device making the device unsuitable for use in an intrinsically system.

# 3. Marking – Numbering System

## 3.1. MARKING

The firm plate (124) is applied on the top of the mechanical compartment housing.

The following data are indicated: manufacturer contact details, serial number, year of manufacturing and instrument electric characteristics.

ATEX marking is described in GEA19100 (400152322) ATEX instruction manual which is supplied with every 12400.

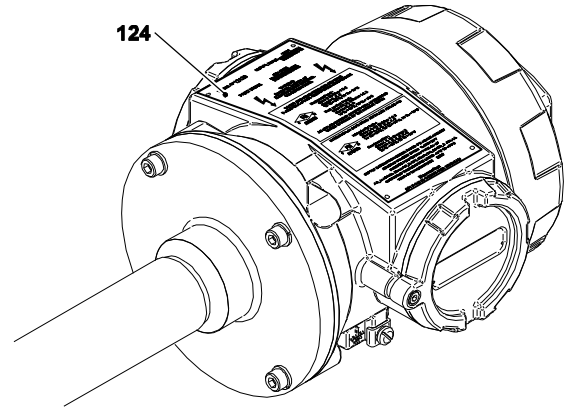

Figure 2 - Marking

## 3.2. NUMBERING SYSTEM

12	4	a	b	C	d
	Model	Action	Mounting	Hazardous Protection	Housing Material
	4 - HART® communication protocol, LCD display and pushbuttons, SIL Certified	<p>1 - Controller with adjustable switches and second 4-20mA analogue output signal: AO_1, AO_2, DO_1, DO_2</p> <p>2 - Transmitter: AO_1</p> <p>3 - Transmitter with adjustable switches and second 4-20mA analogue output signal: AO_1, AO_2, DO_1, DO_2</p>	<p>0 - Top and bottom, Screwed, BW or SW</p> <p>1 - Top and bottom, Flanged</p> <p>2 - Side and side, Flanged</p> <p>3 - Top vessel, Flanged</p> <p>4 - Side vessel, Flanged</p> <p>5 - Top and side, Screwed, BW or SW</p> <p>6 - Side and bottom, Screwed, BW or SW</p> <p>7 - Side and bottom, Flanged</p> <p>8 - Top and side, Flanged</p> <p>9 - Side and side, Screwed, BW or SW</p>	<p>1 - FM &amp; FMc (ex CSA) Intrinsically Safe, Explosion proof, nL and Nema 4X-6P</p> <p>2 - JIS, Explosion proof</p> <p>3 - Rosteknadzor, Intrinsically Safe, Explosion proof, nL and IP 66/67</p> <p>4 - Inmetro, Intrinsically Safe, Explosion proof, nL</p> <p>5 - ATEX &amp; IECEx Intrinsically Safe, Explosion proof, nL and IP 66/67</p> <p>6 - Other approvals (based on ATEX/IEC approvals)</p> <p>7 - Other approvals (not based on ATEX/IEC approvals)</p>	<p>1 - Aluminum with epoxy painting</p> <p>2 - 316L Stainless steel</p>

Note: only the Transmitter function is SIL certified.

# 4. Installation

## 4.1. STORAGE AND CONDITION AT DELIVERY

Level instruments have been carefully packed in our premises to prevent them from damage during handling and transportation.

Units must be stored in an area where temperatures are between  $-50\text{ }^{\circ}\text{C}$  and  $+93\text{ }^{\circ}\text{C}$ .

Units are factory dry calibrated (simulation by weight) to the service specific gravity specified by the customer.

When service specific gravity has not been specified, units are factory dry calibrated to a specific gravity of 1.

Recalibration is recommended when the actual specific gravity differs from calibration specific gravity.

Recalibration is needed when verification of instrument performance is made with liquid in the displacer chamber.

## 4.2. MOUNTING ON SITE

Unpack the unit carefully and record the serial number for future reference. Remove the shipping stud that secures the displacer in the chamber.

Whenever possible, locate the instrument at some easily accessible, well-lighted place on the vessel. The location must have ambient temperature at the instrument case within the range of  $-50\text{ }^{\circ}\text{C}$  to  $+80\text{ }^{\circ}\text{C}$  (unless limitations due to hazardous area approvals – see Section 2).

**Note: Do not remove instrument cover until the unit has been installed and is ready for calibration.**

The codes shown on numbering system indicate the instrument designation as a function of various installation modes, displacer chamber connections, and environmental standard or protection of the case against explosion. Figures 3 and 6 show the various ways of installing the displacer chamber.

### 4.2.1. EXTERNAL MOUNTING

(Chamber Type Model, Figures 3 & 4)

Install the instrument in a vertical position on the side of the tank or vessel, so that the mid-range mark on the chamber is at normal level. The mid-range is marked on the chamber.

The equalizing lines between chamber and vessel must be the same size as the chamber connections. Install a block valve in each line.

The use of a drain connection is recommended as shown in Figure 3.

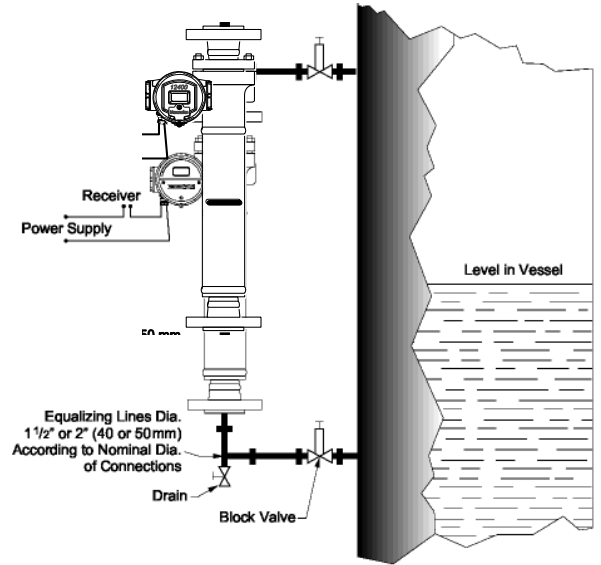
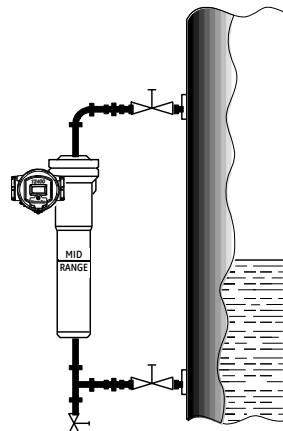
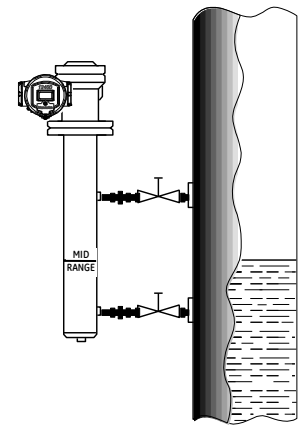

Figure 3 — Typical Installation



Type 12400 (Screwed NPT, BW, SW)  
Type 12401 (Flanged)



Type 12409 (Screwed NPT, BW, SW)  
Type 12402 (Flanged)

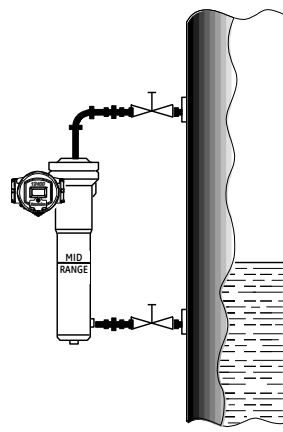

Type 12405 (Screwed NPT, BW, SW)  
Type 12408 (Flanged)

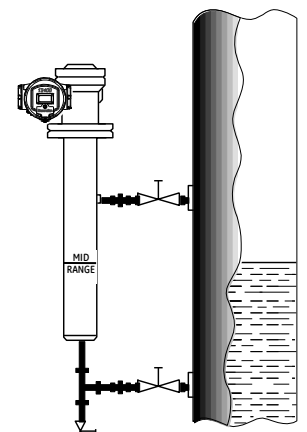

Type 12406 (Screwed NPT, BW, SW)  
Type 12407 (Flanged)

Figure 4

### CAUTION:

The displacer is always immobilized in the displacer chamber to avoid any internal damage during transportation. During the level installation, the displacer has to be unlocked by unscrewing the M6 stern at the drain.

#### 4.2.2. INTERNAL MOUNTING

An internally mounted 12400 Series instrument has no displacer chamber and the mechanism chamber bolts directly to the vessel nozzle flange.

##### a. Type 12403 Top Flange Mounted Instrument (Figure 5)

There are two mounting possibilities:

- Overhead space necessary for mounting the instrument is sufficient:
  - Attach the displacer to the torque tube before bolting the chamber flange to the nozzle flange on the vessel.
- Overhead space is insufficient: in this case, install a detachable hanger extension. Before attaching the extension:
  - Lower the displacer partway into the tank.
  - Fasten and pin the extension to the displacer.
  - Hook the displacer to the torque arm and lower the entire unit into position. When the extension consists of several detachable elements, repeat this operation for each element and lower the displacer progressively into the tank.
  - Mount the instrument and bolt the mechanism chamber onto the nozzle flange.

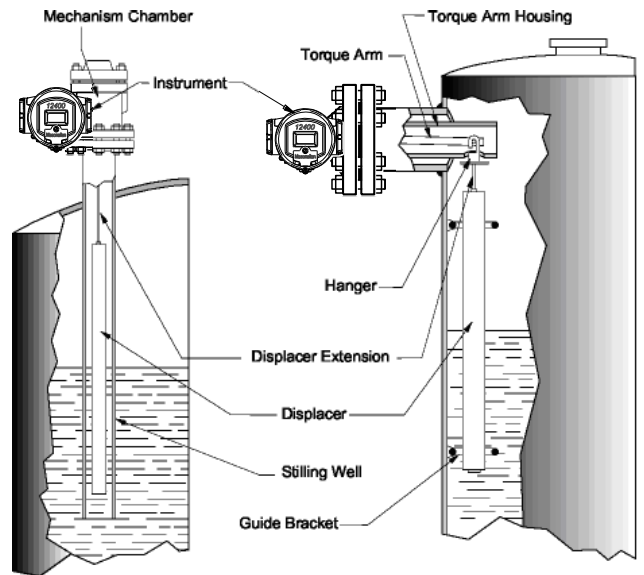

Figure 5  
Type 12403

Figure 6  
Type 12404

##### b. Type 12404 side flange mounted Instrument (Figure 6)

When the instrument is side flange mounted, provide enough clearance to permit attachment of the displacer after the chamber flange is bolted in place. To attach the displacer:

- Reach into the end of the protective case and depress the torque arm.
- Bring the displacer hanger up through the hole in the bottom of the case and slip the displacer hanger over the torque arm pin.
- Lower the displacer until the pin engages the top of the slot in the hanger.

##### 4.2.2.1. Guide brackets for type 12404 (Figure 6)

If the liquid is in motion, provide brackets as shown in Figure 6 to guide the lower end of the displacer. The diameter of the hole must be 25 to 35 mm (1" to 1 1/2") larger than the diameter of the displacer for ranges to 1.8 m (6'), and 50 to 70 mm (2" to 3") larger for greater ranges.

Place the brackets at 50 to 70 mm (2" to 3") from each end of the displacer. Locate the centerline of the hole so that the displacer hangs freely.

##### 4.2.2.2. Stilling well for type 12403 (Figure 5)

If the liquid is turbulent, provide a stilling well.

Make the well from tubing or pipe of a suitable diameter to allow sufficient clearance between displacer and pipe. Mount it so that it extends at least 75 mm (3") below a free hanging displacer.

Provide a hole at the top of the stilling well to equalize pressure between well and vessel.

##### 4.2.2.3. Instrument case mounting (Figure 7)

The standard case mounting is left handed — the case is to the left of the displacer. Right hand mounting is optional. To reverse instrument case mounting, refer to Section 9 - Maintenance.

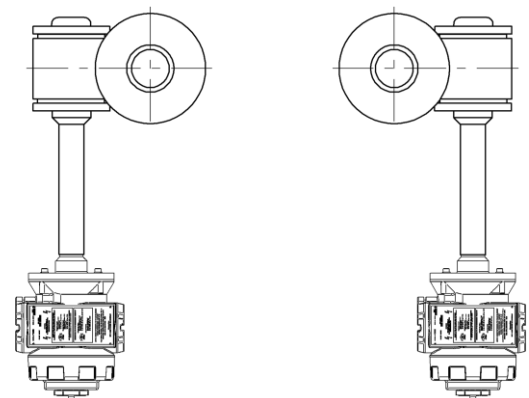

Left mounting  
(top view)

Right mounting  
(top view)

Figure 7



# 5. Case description

The purpose of this section is to describe the various instrument sub-assemblies to facilitate their use and maintenance. See figures 8 to 13.

## 5.1. ELECTRONIC COMPARTMENT

The electronics compartment, located at the front of the instrument, can be accessed by removing the main cover (281). This main cover is equipped with a glass (251) and three explosion proof pushbuttons (260).

The cover (281) is fully screwed on to the case (2) and sealed with an O-ring (109). It may be necessary to unscrew the cover by less than a turn to align the window and LCD display and to install the safety screw (110). The cover (255) protects the pushbuttons.

The sensor S/A (40) and its seal (111) are secured by two screws (112), located in the upper part of the electronics compartment.

The microprocessor, the display and the three pushbuttons are mounted on the resin potted electronic board which makes the main electronic module (200). This subassembly is inserted into the case with the display facing the top of the case. It is assembled by four screws (201).

## 5.2. MECHANISM COMPARTMENT

The mechanism compartment (Figures 12 & 13) on the back of the case has an opening on the right side (operator facing instrument), which is closed by a threaded cover (107) and a gasket (108). A second opening at the bottom, closed by a special 3/4" NPT plug (190), allows access to the mechanical flexure (59), which is part of the beam.

The mechanism (50) is completely factory assembled and calibrated before being installed into the mechanism compartment. The pivot (51) is positioned toward the back of the case through two pins (52-53) and fastened by two screws (113).

Two set screws (114) are located in tapped holes in the side of the case. The holes are covered by two plugs (115).

## 5.3. MTBF

The MTBF (Mean Time Between Failure) of 12400 Series instrument is 55.7 years, according to MIL-STD-HDBK-217F Specification.

## 5.4. CONNECTION COMPARTMENT

Located on the left side, the connection compartment is closed by a threaded cover (104) with O-ring gasket (105) and locked by a safety screw (106). It is equipped with a terminal board (90) mounted with a screw (92).

To mount the safety screw (106), the cover must be fully screwed on the case and then unscrewed by less than a turn.

### **DANGER:**

**FOR ANY ACTION ON 12400 SERIES INSTRUMENT, DO NOT REMOVE EITHER COVER PRIOR TO READING GEA19100 (400152322) ATEX INSTRUCTION MANUAL.**

### 5.4.1. ELECTRIC CIRCUIT

Both the terminal strip and the ground terminal are located in connection compartment (Figures 8 and 9). Connections are done with four flat handle terminal blocks (90) or a terminal board connector (90A) (Japan) and included ground connection (96). Follow strip rules to prevent from any short circuit and comply with local and national standards for hazardous area installations.

A 1/2" NPT (or M20) conduit connection is provided in the lower part of the junction box for connecting the supply leads via a supplied stuffing box with an integrated cable clamp device or any cable gland with cable clamp device suitable for the considered hazardous area.

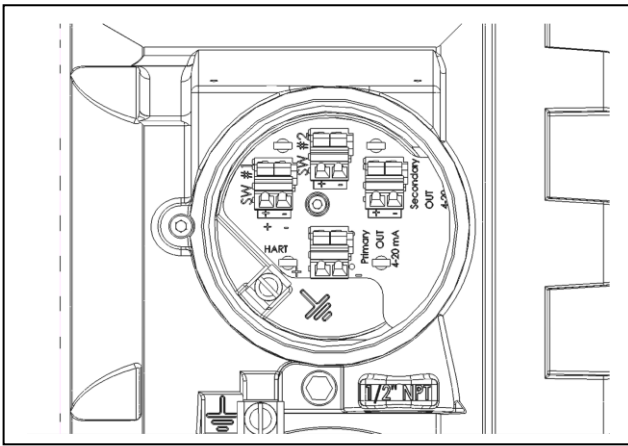

**Figure 8 – Terminal board**  
Standard version with clamp (Ref. #90)

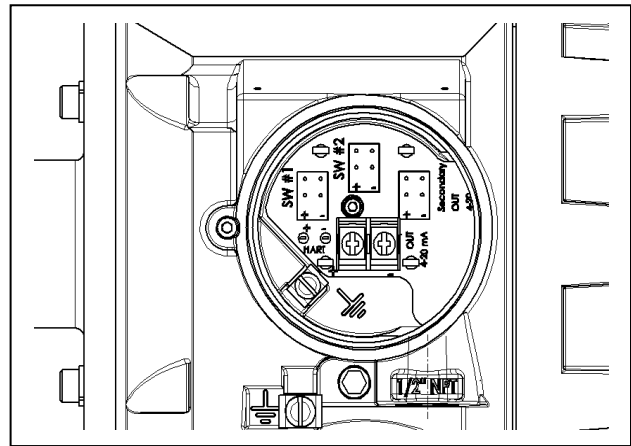

**Figure 9 - Terminal board**  
Japanese version with screws (Ref. #90A)

#### 5.4.2. WIRING AND CONNECTIONS

All wiring and connections must be done in accordance with EN/IEC 60079-14, EN/IEC 61241-14 and/or local and national codes for hazardous area installations.

#### 5.4.3. ALLOWABLE SUPPLY VOLTAGES

Electrical connections on terminal board must respect polarity + and -, as well as maximum allowable supply voltages given below. Connect the instrument to the ground using the ground terminals internally and externally to the case.

Supply Voltage U (VDC)	AO_1		AO_2		DO_1/DO_2	
	MIN	MAX	MIN	MAX	MIN	MAX
<b>Explosion proof</b>	10 V	40 V	10 V	30 V	0.5 V	30 V
<b>Intrinsic Safety</b>	10 V	30 V	10 V	30 V	0.5 V	30 V

#### 5.4.4. MAXIMUM POWER

3 W into 12400 case

#### 5.4.5. OUTPUT SIGNAL AND LOAD RESISTANCE

##### ◆ AO\_1 and AO\_2

Response (scan) time: <60ms

Power interruption without causing reset: <100ms

Power-Up time: < 1s

Compliance with NAMUR NE-43 specification

- standard level measurement: 3.8mA to 20.5mA
- Low or high failsafe signals (severe fault): < 3.6mA or > 21mA

##### ◆ Maximum load resistance

For AO\_1 and AO\_2:  $R_{max} (\Omega) = \frac{U (V) - 10 (V)}{I_{max} (A)}$

##### ◆ DO\_1 and DO\_2

There are two independent isolated output switches with open collectors. 1A maximum output signal. A load resistance must be used in series to limit maximum current. 30 VDC across switch terminals and 1 A cannot exist simultaneously; doing so will result in failure of the digital output circuit.

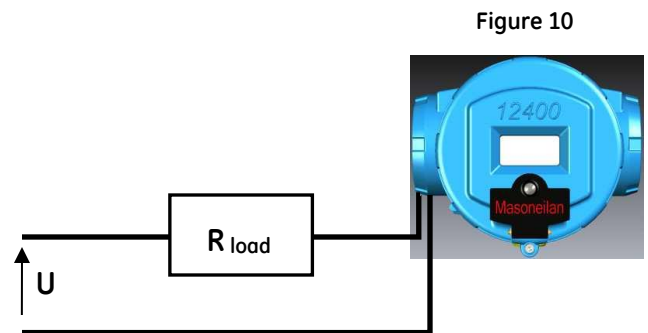

**Figure 10**

#### 5.4.6. Physical and operational specifications (124100, 12420 and 12430 models)

<b>Level Ranges</b>	356, 610, 813, 1219, 1524, 1829, 2134, 2438, 3048mm (14", 24", 32", 48", 60", 72", 84", 96", 120") Other ranges on request
<b>Pressure Range</b>	ANSI class 150 to 2500 PN 10 to PN 420
<b>Ambient Temperature Range</b>	
Standard operating temperature range	-40°C to +80°C (-40°F to +176°F)
Extended operating temperature range	-50°C to +85°C (-58°F to +185°F) - For devices installed in hazardous area, temperature limits depend on the marking. - LCD display may not be readable below -15°C (+5°F) - Beyond standard operating range, performance may be affected by the temperature shift
Storage and Transportation temperature range	-50°C to +93°C (-58°F to +200°F)
<b>Ambient Temperature Shift</b>	±0.028% /°C of full span (zero and span, over extended temperature range)
<b>Process Temperature Range</b>	-210°C to +450°C (-350°F to +850°F) For temperature higher than +150°C (+302°F) or lower than -100°C (-150°F), an extension is required between the case and the torque tube.
<b>Specific Gravity Range</b>	0.15 to 1.4 with a standard displacer Lower and higher specific gravities with special displacers (consult your local sales contact)
<b>Electric Characteristics</b>	
Normal output signal	3.8 to 20.5 mA
Low failsafe output signal	< 3.6 mA
High failsafe output signal	> 21 mA
<b>Supply Voltage</b>	
U min	10 VDC
U max	30 VDC (intrinsic safety) 40 VDC for AO_1 and 30 VDC for AO_2 (flameproof envelope)
<b>Supply Voltage Influence</b>	0.1 µA/V
<b>Over-voltage Protection (at 25°C / 77°F)</b>	10 kW for 8/20 µs pulse wave form 1.5 kW for 10/1000 µs pulse wave form
<b>Electromagnetic Compatibility</b>	Compliance with EMC Directive 2014/30/EU, including NF EN 61000-6-2, NF EN 61326-1, NF EN 61326-3-1, NF EN 61000-6-4 and NF EN 55022 standards.
<b>Accuracy (full span)</b>	Instrument Head Alone : ±0.1% Instrument Head with Torque Tube S/A±0.5%, ±0.25% on request
<b>Hysteresis + Dead Band (full span)</b>	Instrument Head Alone : ±0.1% Instrument Head with Torque Tube S/A±0.3%
<b>Repeatability</b>	Instrument Head Alone : ±0.1% Instrument Head with Torque Tube S/A±0.2%
<b>Enclosure rating</b>	IP66/IP67

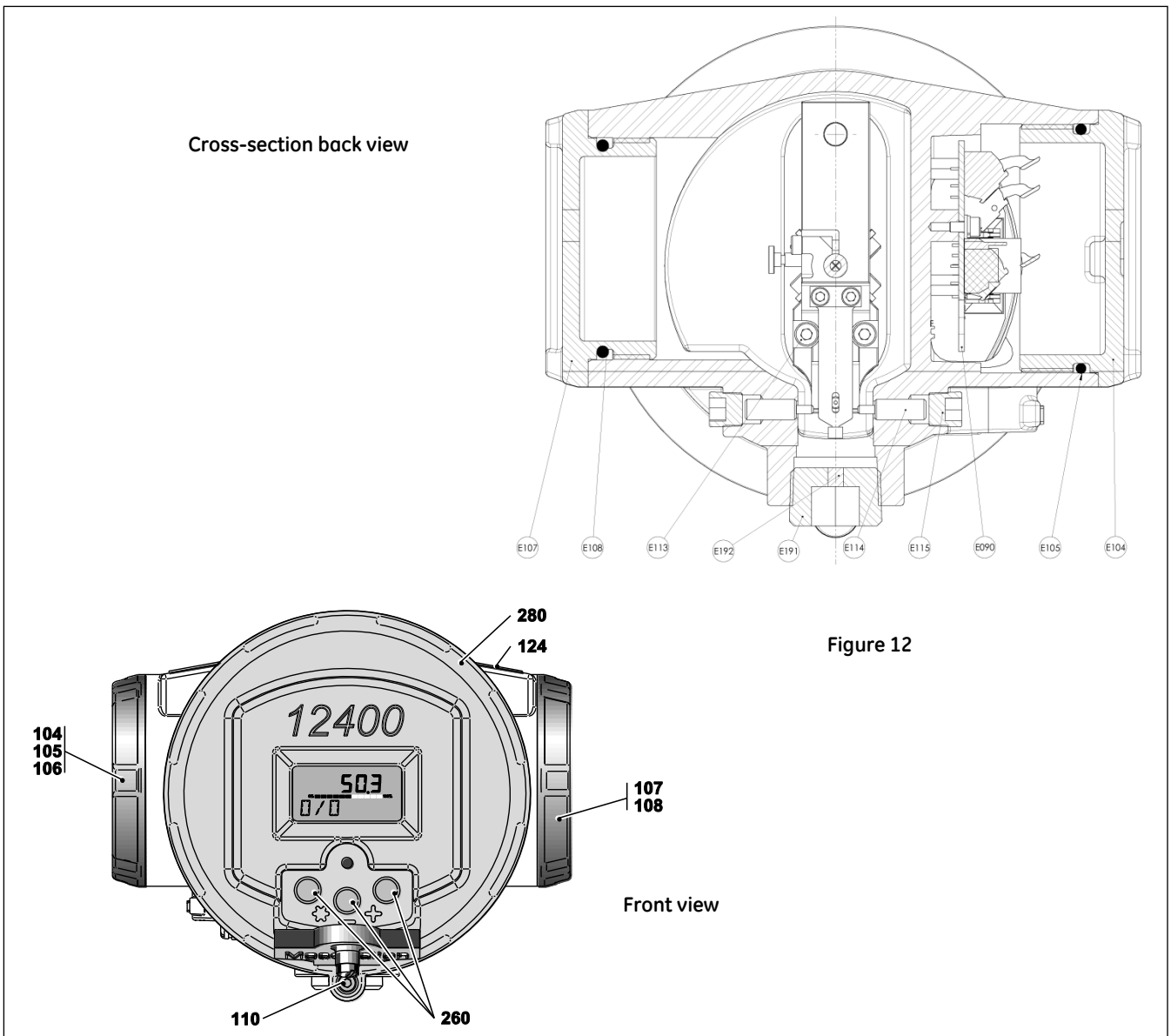
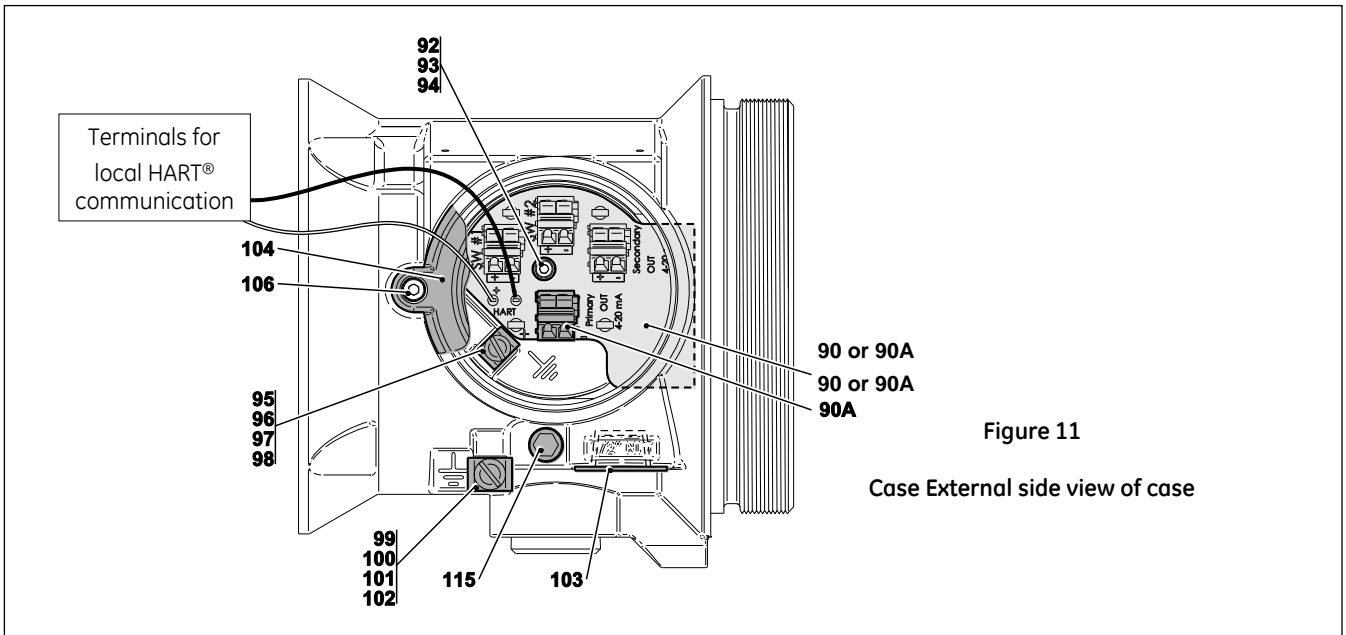

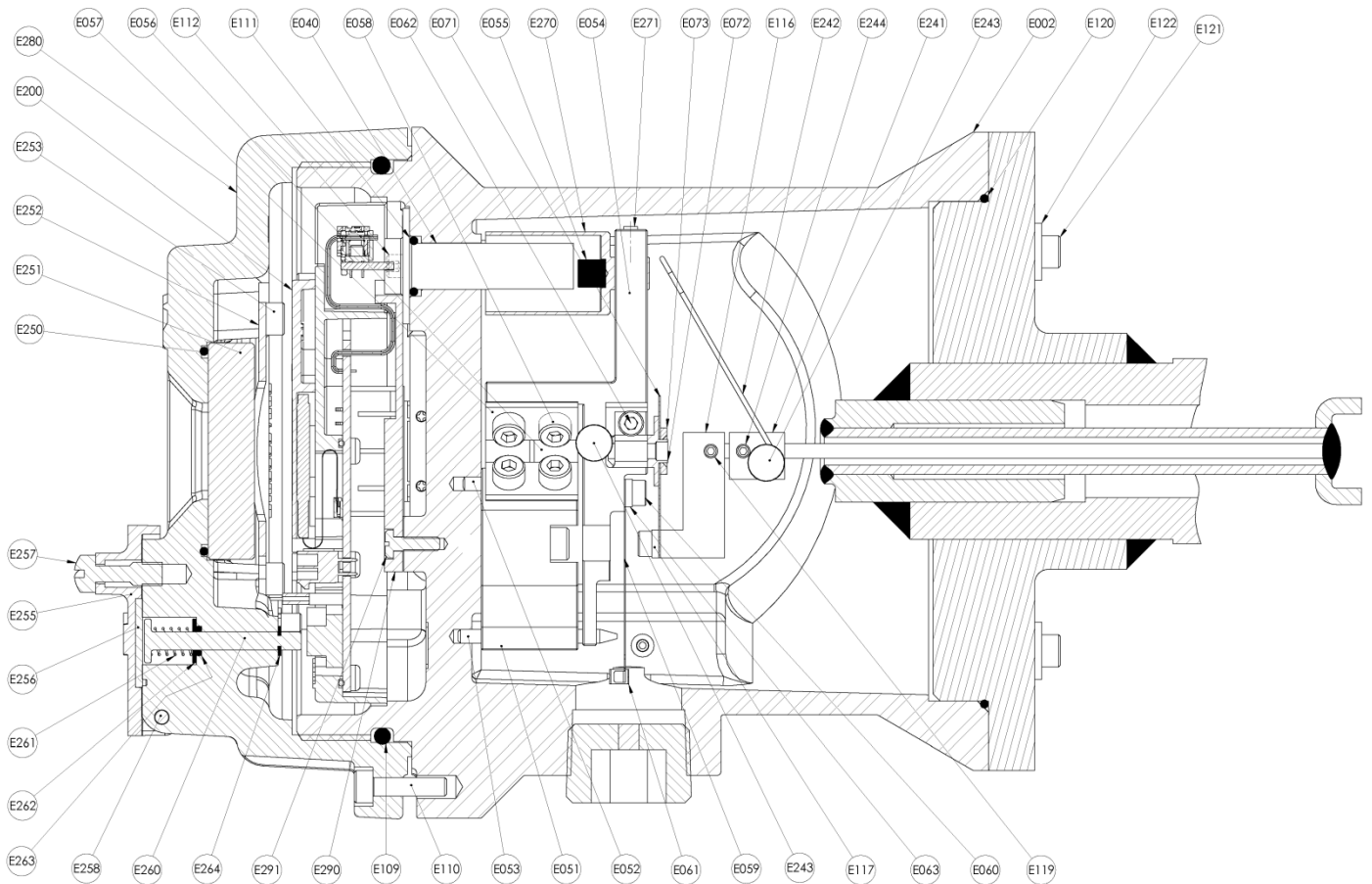

Figure 13 – Cross Section of 12400 Series Digital Level Transmitter/Controller

PARTS REFERENCE

Ref N°	Qty	Parts Name	Ref N°	Qty	Parts Name	Ref N°	Qty	Parts Name
2	1	Case	■ 97	1	C M4-10 screw	■ 190	1	Plug S/A
40	1	Sensor S/A	■ 98	1	Lockwasher	191	1	Plug
50	1	Mechanism S/A	■ 99	1	Flat washer	192	1	Sponge cord
51	1	Pivot	■ 100	1	Clamp	200	1	Main electronic module
52	1	Pin	■ 101	1	C M5-12 screw	■ 201	4	CHC M4-25 screw
53	1	Special pin	■ 102	1	Lockwasher	241	1	Bias S/A
54	1	Beam	■ 103	1	Cap	242	1	Spring arm
55	1	Magnet	■ 104	1	Junction box cover	243	1	pin
56	2	"U" lamella	■ ●	1	O-ring (1)	244	2	Lateral screw
57	4	Flange, lamella	■ 106	1	CHC M4-16 screw	■ 281	1	Main cover S/A
58	8	CHC M4-8 screw	■ 107	1	Visit plug	280	1	Main cover
59	1	Flexible lamella	■ ●	1	O-ring (1)	250	1	Glass O-ring
60	2	CHC M3-8 screw	■ ●	1	O-ring (1)	251	1	Glass
62	1	CHC M3-8 screw	■ 110	1	CHC M4-16 screw	252	1	Clamp, spring
63	1	Flange, lamella	■ 111	1	O-ring, sensor housing	253	4	CHC M4x0.7x10 screw
270	1	Bell	■ 112	2	CHC M3-8 screw	■ 255	1	Cover, pushbuttons
271	1	HC M3-6 screw, bell	■ 113	2	CHC M4-20 screw	■ 256	1	Gasket cover, pushbuttons
70	1	Coupling lamella S/A	■ 114	2	Adjusting screw	■ 257	1	Screw captive panel
71	1	Coupling lamella	■ 115	2	1/8" NPT plug	■ 258	1	Pivot pin, pushbuttons cover
72	1	Pin	■ 75	1	Coupling S/A	■ 259	2	Circlip
73	1	Washer, coupling lamella	116	1	Coupling	260	3	Push Button
90	1	Standard terminal board S/A	117	1	Flange, coupling lamella	261	3	Spring compression
90A	1	Japan terminal board S/A	118	2	CHC M3-8 screw	262	3	Washer, retaining spring
■ 92	1	CHC M3-8 screw	■ 119	2	HC M3-6 screw	263	3	O-ring, pushbuttons
■ 93	1	Flat washer	■ ●	1	O-ring	264	3	Circlip
■ 94	1	Lockwasher	■ 121	4	CHC M6 screw	■ 290	1	Cable protector
■ 95	1	Flat washer	■ 122	4	Lockwasher	■ 291	1	Screw
■ 96	1	Clamp	124	1	Serial plate			

● Recommended spare parts

■ Spare parts available

Note 1: These 3 rings are part of a kit.

# 6. Operating the instrument

## 6.1. GENERAL PRINCIPLES

All digital settings of the 12400 instrument are made by means of three pushbuttons and a liquid crystal display on the front of the instrument, or using HART® communication handheld terminals or BHGE's Masoneilan software: ValVue\*, ValVue AMS\* Snap-on and ValVue PRM\*. Instrument settings can also be performed with any software compliant with FDT/DTM protocol.

The codes or values displayed by the LCD can be seen through a window on the main cover. Access to the three pushbuttons is obtained by opening the cover (255). It is not necessary to open the main cover for calibration or adjustment of the instrument. Except for maintenance and out of hazardous area, the cover must remain closed.

### 6.1.1. THE LIQUID CRYSTAL DISPLAY (LCD)

The LCD displays simultaneously two lines of nine ASCII characters and one line of seven digital characters.

The display is also used to configure, calibrate and diagnose the 12400 instrument.

For ease of operations, values, codes or short names appear on the display. The various parameters are listed in the menus (see Appendixes A, B, C, D, E, F and G).

### 6.1.2. PUSHBUTTONS

Three pushbuttons (260) are located behind the cover (255) on the front of the instrument.

- ◆ The left button is marked with a star ✱, the middle button with the sign −, and the right one with the sign +.
- ◆ ✱ means enter the function, accept or save to memory. It may be understood as "YES".
- ◆ + or − means vertical movement in the program structure. It may be understood by "NO" or "NEXT" or "PREVIOUS".

#### **NOTE:**

- ◆ *Do not over push on the buttons. Press a button at least one second to perform the action.*
- ◆ *Accidental pushing of any of the buttons will not cause any malfunction.*

After using the buttons, check instrument is in back to NORMAL mode, which displays in sequence the current signal and the level of liquid. Close the cover (255).

### 6.1.3. OPERATING MODES

The instrument can operate under three modes with associated menus:

- ◆ **NORMAL Mode:** It is the normal operating mode. As a level transmitter, the 4-20 mA output signal (AO\_1) is proportional to the level in the tank. As a level controller, the 4-20 mA output signal (AO\_1) is the controller output. The local digital display alternately displays loop current and level expressed in the unit (% or engineering unit) shown in the low left corner of the screen. Reading of the instrument database is possible.
- ◆ **SETUP Mode:** Mode to set parameters of the instrument (configuration, calibration or diagnostic) or to read data. The output current is not proportional to the tank level.
- ◆ **FAILSAFE Mode:** The instrument automatically sets to the failsafe mode when a severe error has occurred. The output current is set to the value entered in the ADVANCED SETUP Menu.

#### 6.1.4. PUSHBUTTONS MENUS DESCRIPTION AND HOW TO USE THEM

Seven Appendixes (A, B, C, D, E, F and G) detail the communication paths inside each menu and give descriptions and explanations of each function.

- ◆ **NORMAL Menu** (see Appendix A).
- ◆ **SETUP Menu** (see Appendix A).
- ◆ **BASIC SETUP Menu** (see Appendix B).
- ◆ **ADVANCED SETUP Menu** (see Appendix C).
- ◆ **ENGINEERING UNIT Menu** (see Appendix D).
- ◆ **FILTERING Menu** (see Appendix D).
- ◆ **4-20mA GENERATION Menu** (see Appendix E).
- ◆ **AUTOMATIC TUNING Menu** (see Appendix E).
- ◆ **VIEW DATA Menu** (see Appendix F).
- ◆ **FAILSAFE Menu** (see Appendix G).
- ◆ **VIEW ERROR Menu** (see Appendix G).

##### 6.1.4.1. NORMAL Menu (Appendix A)

To enter NORMAL Menu from normal operating mode, press any button.

NORMAL menu allows to:

- ◆ Enter SETUP menu in order to set all instrument parameters.
- ◆ Access VIEW DATA menu (Appendix F) where the user can READ ONLY all current configuration, calibration and diagnostics data saved in the instrument.
- ◆ View all faults which have occurred since the last fault clear with VIEW ERROR menu (Appendix G).
- ◆ Clear all faults with CLEAR FAULT function (Appendix G).
- ◆ Come back to normal operating mode: display in sequence of level variable and output current.

##### 6.1.4.2. SETUP Menu (Appendix A)

SETUP menu allows to:

- ◆ Enter BASIC SETUP menu (Appendix B) to set all basic configuration and calibration parameters for a quick commissioning.
- ◆ Enter ADVANCED SETUP menu (Appendix C) to set all advanced configuration and calibration parameters for complete management of process constraints and user practices.
- ◆ Come back to NORMAL menu.
- ◆ Access VIEW DATA menu (Appendix F) where the user can READ ONLY all current configuration, calibration and diagnostics data saved in the instrument.
- ◆ View all faults which have occurred since the last fault clear with VIEW ERROR menu (Appendix G).
- ◆ Clear all faults with CLEAR FAULT function (Appendix G).

##### 6.1.4.3. ENGINEERING UNIT Menu (Appendix D)

This menu allows the user to:

- ◆ Define the desired engineering unit for the level variable (% , cm , cm<sup>3</sup> ...).
- ◆ Define the lower and higher level values (zero and span) expressed in engineering unit.

##### 6.1.4.4. FILTERING Menu (Appendix D)

This menu allows the setting of the two filterings available in the instrument:

- ◆ Damping adjustment (analog filtering).
- ◆ Smart filtering parameters tuning.

#### **6.1.4.5. 4-20mA GENERATOR Menu (Appendix E)**

This menu enables generation of a loop current to a defined value independently of true level measurement. This function is of help to set another instrument (such a positioner) in series in the loop, by generating the required output current.

#### **6.1.4.6. AUTOMATIC TUNING Menu (Appendix E)**

This menu enables to automatic tuning of the smart filtering parameters.

#### **6.1.4.7. FAILSAFE Menu (Appendix G)**

This menu is available only when the instrument failed and went to FAILSAFE mode. Then, the output signal is locked in low or high failsafe value (see Advanced Setup menu).

This menu allows the user to:

- ◆ Enter SETUP menu to change any parameter.
- ◆ Come back to normal operating mode: display in sequence of level variable and output current.
- ◆ Perform a reset of the instrument.
- ◆ Access VIEW DATA menu (Appendix F) where the user can READ ONLY all current configuration, calibration and diagnostics data saved in the instrument.
- ◆ View all faults which have occurred since the last fault clear with VIEW ERROR menu (Appendix G).
- ◆ Clear all faults with CLEAR FAULT function (Appendix G).



# 7. Commissioning

This section is based on the following assumptions:

- ◆ 12400 head has previously been mounted on a torque tube without coupling adjustment.
- ◆ Torque arm is mounted according to site requirements, if calibration has previously been done at workshop.
- ◆ Instrument is powered.

The steps described in the following pages for instrument settings and checking are done with the three pushbuttons and the LCD display.

To perform 12400 commissioning through HART communication ValVue\* software or handheld terminal, consult related instruction manuals. Setting and calibration procedures are similar as based on the same philosophy.

Perform the following actions in the order given. They are also used for maintenance purposes. Several calibration procedures are provided to cover available solutions at workshop and on site.

## 7.1. INSTRUMENT COUPLING TO THE TORQUE TUBE

**Note:** *It is necessary to know the mounting direction (right or left) in order to correctly adjust the torque arm. See figures 7 and 23.*

a. Remove the screw (106), the covers (104 & 107) of the connection and mechanism compartments, and the plug (190) located at the bottom of the instrument.

b. **Required level of liquid for coupling:**

b1. At workshop with weights:

Coupling between torque tube and mechanism is achieved by simulating a half level of a 1.4 specific gravity liquid with weights. Attach to the torque arm a weight equivalent to that of a displacer half immersed in a 1.4 specific gravity liquid according to the following calculation:

**Simulated weight =**

$$\text{Actual displacer weight} - \frac{(\text{Actual volume displacer} \times 1.4)}{2}$$

i.e.  $1362 - 907 \times 1.4 / 2 = 727.1 \text{ g}$  for a standard displacer

b2. On site with the process liquid(s):

Two situations may occur:

- If the **specific gravity (or the difference of the density in case of an interface service)** of the available liquid **is between 0.7 and 1.4:**  
Simulate half level h (1.4) of a 1.4 specific gravity liquid with a calculated value h (d) of the available liquid (refer to chart Figure 14).
- If the **specific gravity (d3) (or the difference of the density in case of an interface service)** of the available liquid **is below 0.7:** Perform the coupling at high level in liquid service (immersed displacer) or at high level of the highest spec gravity liquid in interface application.

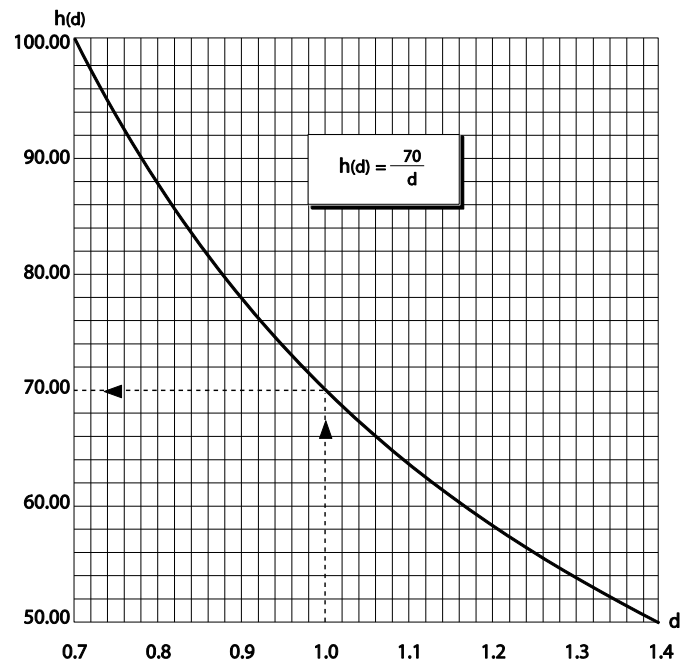

Figure 14  
Curve of Half Level Simulation in a Liquid with S.G.  
between 0.7 and 1.4

### CAUTION:

**In this situation, the instrument must be used for specific gravities (or the difference of SG) ranging from 0.15 to 2xd3.**

- c. Enter the BASIC SETUP menu to display [COUPLNG:%].
- d. Look through the side orifice and verify that the screw (62) coupling end of the beam (54) is loose and that the spring arm (242) is disengaged from the pin (243). Through the 3/4 " NPT hole at the bottom of the case, push the flexure (59) from left to right with your finger to verify it is possible to move the beam (54). The value displayed should vary accordingly. **Pin (72) must rotate freely inside the coupling end of the beam.**
- e. Look at the mechanism through the lateral orifice, and index the oval hole of the flexure towards the special conical ended pin (53) by bending the flexure (59) toward the case front (see Figure 15). The value read on the LCD must be between -5% and +5%.  
*NOTE:* Check there is no oscillation of the weight used to simulate the displacer.
- f. While holding the flexure (59) in that position, slightly but firmly tighten the screw (62) using a 2.5 mm Allen wrench.

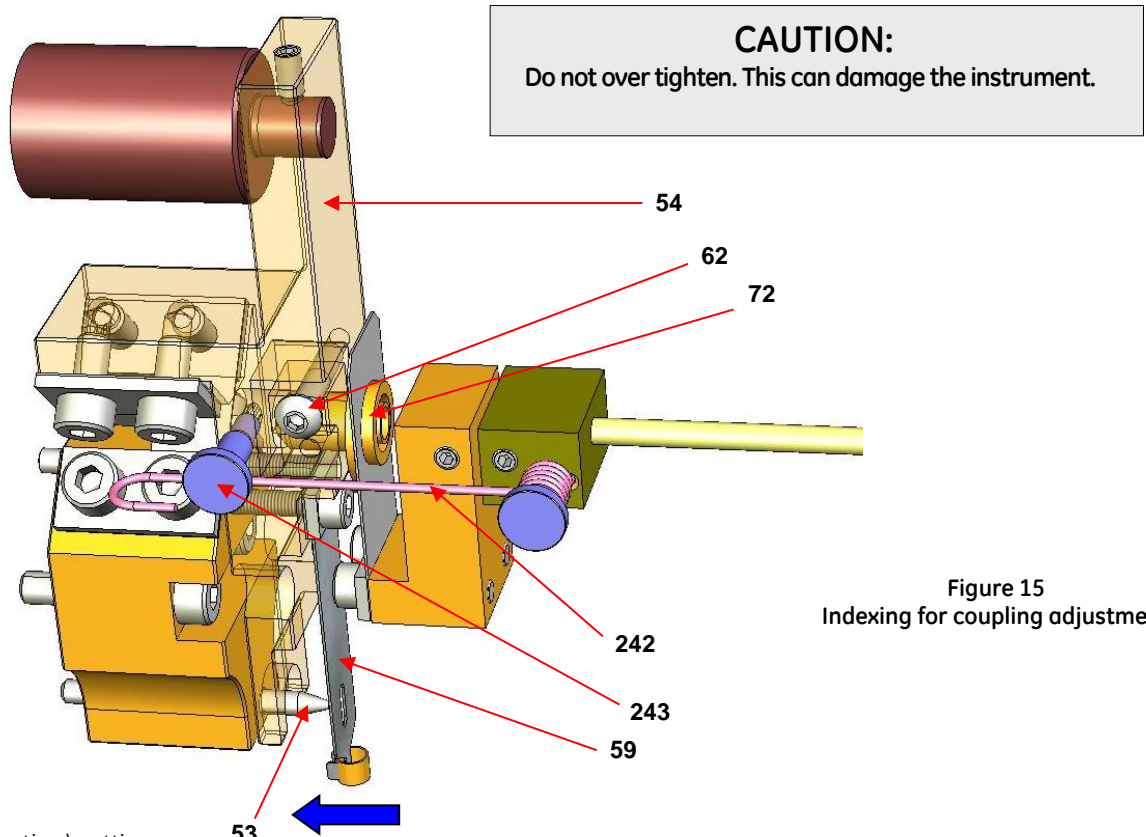

Figure 15  
Indexing for coupling adjustment

- g. Bias (spring arm function) setting
  - g1. Index again the flexure (59) on the conical ended pin (53).
  - g2. Move the spring arm (242) below the pin (243) on the beam. The pin has a groove to position correctly the spring. Check the spring arm is locating inside the pin groove.
  - g3. Relax the flexible lamella, check the weight stability and control the value on the LCD is always inside +/-5%.

## 7.2. TRANSMITTER CONFIGURATION

Always perform or check instrument configuration before any calibration procedure. Configuration defines 12400 operating mode, validates various features or sub-menus activation and impacts instrument internal diagnostics.

Check the following key features before initiating any calibration procedure:

- ◆ Measurement function: LEVEL or INTERFACE.

For special applications, it might be of interest to set the instrument in interface mode even for a level measurement. In this case low specific gravity is set at 0.

- ◆ Mounting position of the instrument head versus displacer: LEFT or RIGHT.

An incorrect configuration causes calibration errors that may impact instrument operating and advanced diagnostics capabilities.

- ◆ Loop current action: DIRECT or REVERSE.

This function both applies on AO\_1 and AO\_2 (main and second 4-20 mA output signals).

### **CAUTION:**

**In case of failsafe signal use ([FAIL LOW] or [FAIL HIGH]), check that loop current variations are in line with process and safety rules implemented into the Distributed Control System.**

- ◆ See Appendixes A to G which describe operating and setting menus.

## 7.3. TRANSMITTER CALIBRATION

### 7.3.1. OPERATING RULES AND CALIBRATION PRINCIPLE

The purpose of this chapter is to detail internal device operating rules to understand names of functions and describe actions generated by the embedded firmware during calibration. Advanced settings are also described to answer user constraints. In some cases, the user can avoid doing a new calibration following a process change or can enable a level measurement on a specific range different than the standard one.

#### ◆ Specific Gravity of Calibration:

Specific Gravity of Calibration is unique in level service and double in interface service. If Specific Gravity of Calibration is unknown (enter 1.0 in level service, and 1.0 and 0.001 in interface service as default values) or known without accuracy, calibration is still possible. However, automatic setting of the Specific Gravity of Service will not be correctly performed or may generate measurement errors.

The Specific Gravity of Calibration is that of the liquid used (or simulated by weights) for zero and span calibration in the BASIC SETUP menu. Modify it only if zero and span calibration are performed again for a liquid of different specific gravity. See Section 7.3.3.

#### ◆ Specific Gravity of Service:

Specific Gravity of Service is unique in level service and double in interface service.

The Specific Gravity of Service is the one used for the function [SG SERV] in the BASIC SETUP menu. Its value is identical to that of [SG CALIB] just after calibration. If the specific gravity of the process liquid is different, simply modify the value of [SG SERV] without performing a new calibration.

### CAUTION:

In interface service, if the [LSG SERV] and/or [HSG SERV] are modified, an automatic calculation is performed to set a new value in [Z SHIFT:%].

#### ◆ Reduced Span and/or zero shift:

For an application where the level change is smaller than the displacer height, it is possible to obtain the full signal range for this reduced level range thanks to Reduced Span and Zero Shift functions.

**Example:** To modify a calibration so that 0 % corresponds to a displacer immersed to 1/4 of its height (25%), and 100% corresponds to a displacer immersed to 4/5 of its height (80%), adjust zero shift to 25 % and span reduction to 45 %. See schematic on Figure 16.

### CAUTION:

If a new calibration is performed, the parameters of the reduced range [R SPAN:%] and/or zero shift function [Z SHIFT:%] are automatically set to zero.

In interface service, if the [LSG SERV] and/or [HSG SERV] are modified, an automatic calculation is performed to set a new value in [Z SHIFT:%].

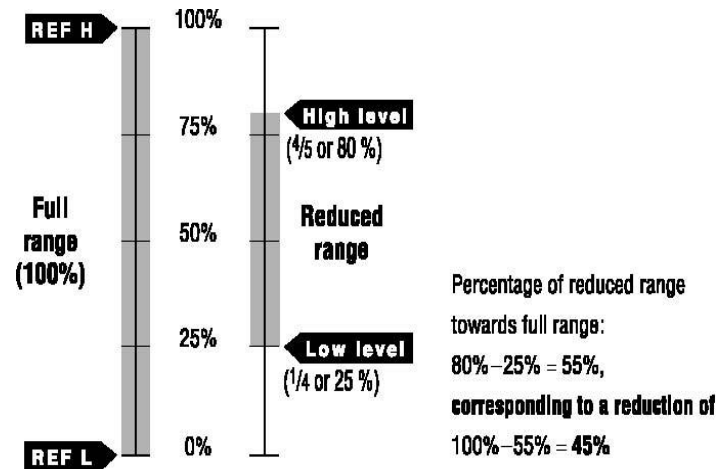

Figure 16

Schematic example of reduced range

- **[ZERO]:** Corresponds to the low level reference; usually to the displacer not immersed in level application or to the displacer fully immersed in lower specific gravity in an interface application.
- **[SPAN]:** Corresponds to the high level reference; usually to the displacer fully immersed in level application or fully immersed in higher specific gravity in an interface application.

◆ Calibration of transmitter for level application:

The electronic circuit is calibrated towards two reference levels (REF L and REF H). See schematic below.

- REF L corresponds to the displacer completely out of liquid.
- REF H corresponds to the displacer fully immersed in the liquid of Specific Gravity used for calibration [SG CALIB].

The loop current corresponding to REF L may be set through [MA LO:mA] via [VAR SET]; it is generally 4mA.

The current corresponding to REF H may be set through [MA HI:mA] via [VAR SET]; it is generally 20mA.

The value of [MA HI:mA] must always be higher than the value of [MA LO:mA].

The level indication corresponding to REF L is set through function [LRV] via [VAR SET]; it is expressed in the unit set through [UNIT] function; if UNIT is "%", [LRV] must be 0.00%.

The level indication corresponding to REF H is set through function [URV] via [VAR SET]; it is expressed in the unit set through [UNIT] function; if UNIT is "%", [URV] must be 100.00%.

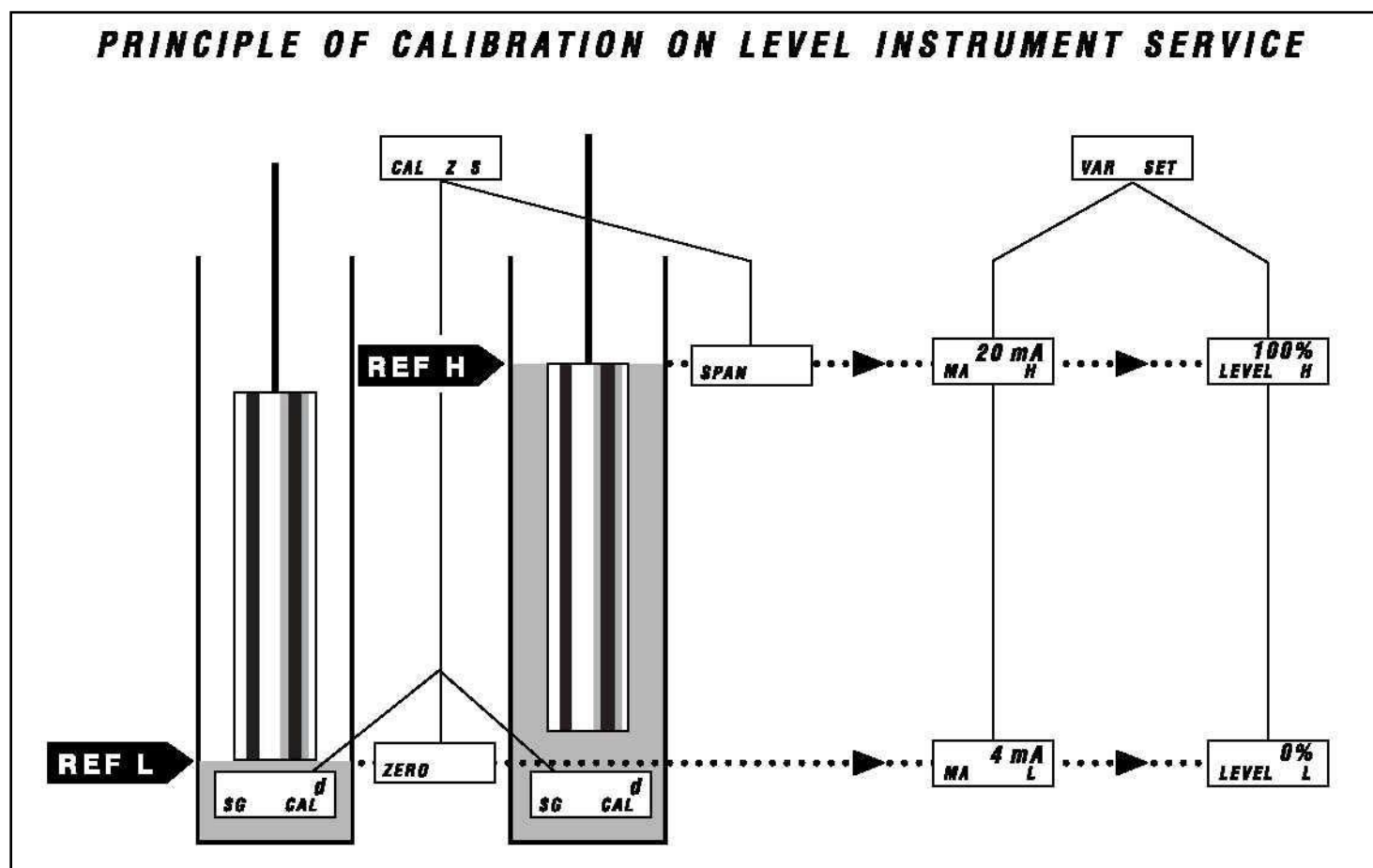

◆ Calibration of transmitter for interface application:

The level transmitter is used to measure the interface level of two immiscible liquids of different specific gravities. The displacer must always be fully immersed.

The electronic circuit is calibrated towards two reference levels (REF L and REF H). See schematic below.

- REF L corresponds to the displacer completely immersed in the liquid of Lower Specific Gravity used for calibration [LSG CALIB].
- REF H corresponds to the displacer fully immersed in the liquid of Higher Specific Gravity used for calibration [HSG CALIB].

The loop current corresponding to REF L may be set through [MA LO:mA] via [VAR SET]; it is generally 4mA.

The current corresponding to REF H may be set through [MA HI:mA] via [VAR SET]; it is generally 20mA.

The value of [MA HI:mA] must always be higher than the value of [MA LO:mA].

The level indication corresponding to REF L is set through function [LRV] via [VAR SET]; it is expressed in the unit set through [UNIT] function; if UNIT is "%", [LRV] must be 0.00%.

The level indication corresponding to REF H is set through function [URV] via [VAR SET]; it is expressed in the unit set through [UNIT] function; if UNIT is "%", [URV] must be 100.00%.

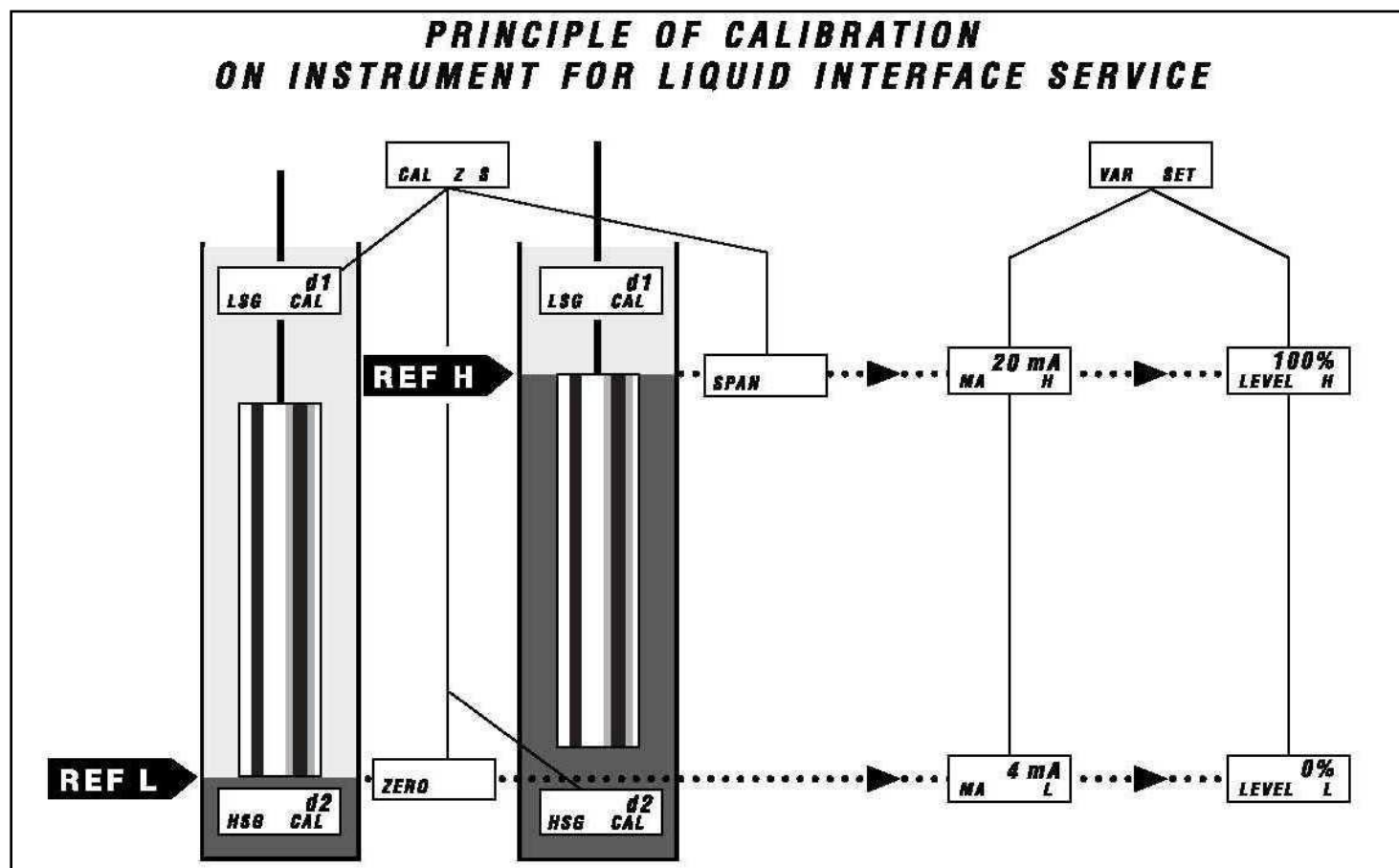

### 7.3.2. CALIBRATION AT WORKSHOP WITH WEIGHTS

- a. From [BAS SETUP] menu, enter the [CALIB Z S] sub-menu.
- b. Enter specific gravity of calibration in level application [SG CALIB] or the low and high specific gravities in interface application [LSG CALIB] and [HSG CALIB].

#### CAUTION:

During the dry calibration without mechanism chamber, DO NOT ATTACH SPECIAL INTERFACE DISPLACER (OR ITS EQUIVALENT EFFECTIVE WEIGHT) on the torque arm. Indeed, these displacers being heavier than those for liquid level service and no mechanical stop being available without of mechanism chamber, the torque tube and/or the instrument mechanism would be damaged.

<u>Standard displacer characteristics</u>	<u>S.I Units</u>	<u>English Units</u>
Displacer weight	1362 g	3 lbs
Displacer volume	907 cm <sup>3</sup>	55.34 in <sup>3</sup>
Fluid specific gravity		

Actual volume and weight of the displacer can be read using HART communication (if data have been previously saved into the 12400 instrument memory). Otherwise actual volume of the displacer is marked on the firm plate and displacer weight can be measured by weighting of it.

#### c. Low Level [ZERO]

##### c1. Liquid application:

Attach to the torque arm a set of weights equivalent to the true displacer weight (i.e. 1362 g for a standard displacer) to simulate the low level.

##### c2. Interface application:

Attach to the torque arm a set of weights equivalent to the displacer weight completely immersed in the liquid of Lower Specific Gravity used for calibration [LSG CALIB] using the following formula:

$$\text{Displacer Apparent Weight for REF B} = \text{Displacer Actual Weight} - (\text{Displacer Actual Volume} \times [\text{LSG CALIB}])$$

- c3. Enter and validate the [ZERO]: the [LEVEL:%] value indicated on the display must equal to 0.0%. If not, restart the procedure until very close to this value. See Appendix B.

**d. High Level [SPAN]**

**d1. Liquid application:**

Attach to the torque arm a set of weights equivalent to the apparent weight of the displacer fully immersed in the calibration fluid with Specific Gravity of Calibration [SG CALIB], i.e.:

$$\begin{aligned} \text{Displacer Apparent Weight for REF H} &= \\ &\text{Displacer Actual Weight} - (\text{Displacer Actual Volume} \times [\text{SG CALIB}]) \\ &\text{i.e. } 1362 - 907 \times 1 = 455 \text{ g for a standard displacer and water} \end{aligned}$$

**d2. Interface application**

Attach to the torque arm a set of weights equivalent to the displacer weight completely immersed in the liquid of Higher Specific Gravity used for calibration [HSG CALIB] using the following formula:

$$\begin{aligned} \text{Displacer Apparent Weight for REF H} &= \\ &\text{Displacer Actual Weight} - (\text{Displacer Actual Volume} \times [\text{HSG CALIB}]) \end{aligned}$$

**d3.** Enter and validate the [SPAN]: the [LEVEL:%] value indicated on the display must equal 100.0%. If not, restart the procedure until very close to this value. See Appendix B.

**e.** Press the \* button when [SAVE] is displayed to validate the [ZERO] and [SPAN] settings.



### 7.3.3. CALIBRATION ON SITE WITH PROCESS FLUIDS

- a. From [BAS SETUP] menu, enter the [CALIB Z S] sub-menu.
- b. Enter specific gravity of calibration for level application [SG CALIB] or the low and high specific gravities for interface application [LSG CALIB] and [HSG CALIB].
- c. Take all necessary actions to enable level variations into the displacer chamber: open/close isolation valves, vent, purge ...
- d. Empty and fill the displacer chamber with fluid(s) of service to get level variations.
- e. Wait for a few seconds until the displacer stabilizes to validate and save the values displayed on the LCD after each level variation.
- f. **Low Level [ZERO]**
  - f1. **Liquid application:**  
Empty the displacer chamber.
  - f2. **Interface application:**  
Fully immerse the displacer in the liquid of Lower Specific Gravity used for calibration [LSG CALIB].
  - f3. Enter and validate the [ZERO]: the [LEVEL:%] value indicated on the display must equal to 0.0%. If not, restart the procedure until very close to this value. See Appendix B.
- g. **High Level [SPAN]**
  - g1. **Liquid application:**  
Fully immerse the displacer in the liquid of Specific Gravity used for calibration [SG CALIB].
  - g2. **Interface application:**  
Fully immerse the displacer in the liquid of Higher Specific Gravity used for calibration [HSG CALIB].
  - g3. Enter and validate the [SPAN]: the [LEVEL:%] value indicated on the display must be equal 100.0%. If not, restart the procedure until very close to this value. See Appendix B
- h. Press the \* button when [SAVE] is displayed to validate the [ZERO] and [SPAN] settings.

### 7.3.4. CALIBRATION WITH MECHANICAL STOPS

#### CAUTION:

This procedure is only possible if mechanical stops (adjusting screws) have been previously adjusted upon process fluids. See mechanical stops setting Section 7.5.

This calibration procedure is very useful on site and for interface application when there is no capability to make level variations into the tank.

- a. Open the access plug (107) on the right side of the case to look at the simulation mechanism. Remove plug (190) and the two 1/8" NPT plugs (115). Use a 5 mm Hex wrench.
- b. Simulate level variations by moving the flexure (59) in the direction of the torque tube until the flexure touches the adjusting screw post (114).
- c. While maintaining contact, slide the flexure left or right along the surface of the screw post (figure 17) to simulate low and high level values of the process fluid(s).

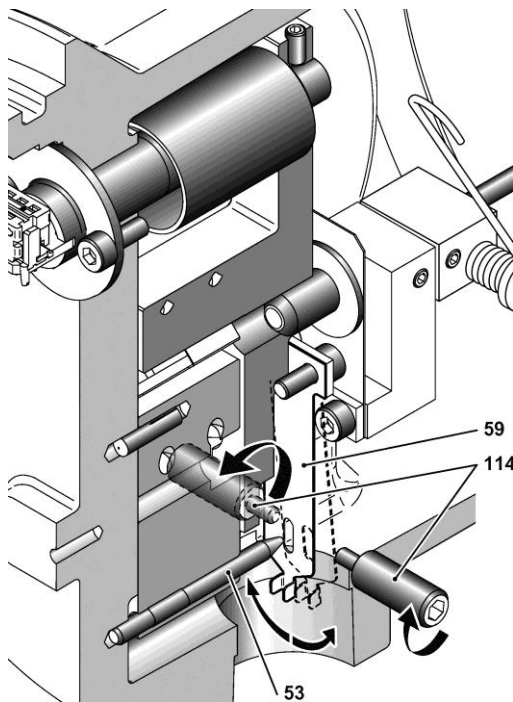

Figure 17  
Calibration with adjusting screws

- d. Enter [BAS SETUP] menu and the [CALIB Z S] sub-menu.
- e. Enter specific gravity of calibration in level application [SG CALIB] or the low and high specific gravities in interface application [LSG CALIB] and [HSG CALIB].
- f. **Low Level [ZERO]**
  - f1. **Liquid application:**  
Move the flexure (59) against the adjusting screw shoulder (114), which corresponds to the low level (opposite side to the displacer). Wait for a few seconds until the displacer stabilizes.
  - f2. **Interface application:**  
Move the flexure (59) against the adjusting screw shoulder (114), which corresponds to the lowest specific gravity fluid of calibration [LSG CALIB] (opposite side to the displacer). Wait for a few seconds until the displacer stabilizes.
  - f3. Enter and validate the [ZERO]: the [LEVEL:%] value indicated on the display must equal 0.0%. If not, restart the procedure until very close to this value. See Appendix B.

**g. High Level [SPAN]**

**g1. Liquid application:**

Move the flexure (59) against the adjusting screw shoulder (114), which corresponds to the high level of calibration fluid [SG CALIB] (on displacer side). Wait for a few seconds until the displacer stabilizes.

**g2. Interface application:**

Move the flexure (59) against the adjusting screw shoulder (114), which corresponds to the high level of highest specific gravity fluid of calibration [HSG CALIB] (on displacer side). Wait for a few seconds until the displacer stabilizes.

**g3.** Enter and validate the [SPAN]: the [LEVEL:%] value indicated on the display must equal 100.0%. If not, restart the procedure until very close to this value. See Appendix B.

**h.** Press the \* button when [SAVE] is displayed to validate the [ZERO] and [SPAN] settings.

**i.** Reinstall all plugs (107), (190), and (115).

## 7.4. CALIBRATION OF SPECIFIC GRAVITY METER

This adjustment is made at the factory for complete instruments. The specific gravity function [SG METER] is very useful in performing on site new calibrations, simulations with or without liquid and direct reading of specific gravity of liquids on the application.

### CAUTION:

The Specific Gravity Meter function is factory calibrated at a specific gravity of 1.0 for a complete instrument only if the displacer volume is lower than 1270 cm<sup>3</sup> and the weight is 1362 g.

For an instrument delivered alone with a torque tube, the Specific Gravity Meter function is factory calibrated at a S.G. 1.0 for a displacer with 907 cm<sup>3</sup> volume and 1362 g weight.

If actual displacer characteristics differ from these values, recalibration is required and is possible only if displacer volume is lower than 1270 cm<sup>3</sup> and if service specific gravity x displacer volume is lower than 1270.

Reading of the specific gravity of a liquid is possible only when displacer is fully immersed into the liquid and if [SG METER] function has been previously calibrated.

- a. Into the [ADV SETUP] menu, enter the [SGM CALIB] sub-menu. See Appendix C.
- b. Enter the Specific Gravity of Calibration of the S.G. Meter [SG CALIB] =1.0
- c. **LOW LEVEL [ZERO]**
  - c1. Attach a set of weights to the torque arm equivalent to the true displacer weight (i.e. 1362 g for a standard displacer) to simulate the low level or empty the displacer chamber.
  - c2. Enter and validate the [ZERO]: the [LEVEL:%] value indicated on the display must equal 0.0%. If not, restart the procedure until very close to this value. See Appendix C.
- d. **HIGH LEVEL [SPAN]**
  - d1. Attach a set of weights to the torque arm equivalent to the apparent displacer weight in high level position with Specific Gravity of Calibration [SG CALIB] 1.0 or fill the displacer chamber up to the high level position. Stabilise the displacer (or weights).

<u>Parameter name</u>	<u>S.I Units</u>	<u>English Units</u>
Displacer weight	g	lbs
Displacer volume	cm <sup>3</sup>	in <sup>3</sup>
Fluid specific gravity		

<p><b>Displacer Apparent Weight for REF H=</b></p> <p>Displacer Actual Weight - (Displacer Actual Volume X [SG CALIB])</p> <p>i.e. 1362 - 907 x 1 = 455 g for a standard displacer and water</p>
--

Actual volume and weight of the displacer can be read using HART communication (if data have been previously saved into the 12400 instrument memory). Otherwise actual volume of the displacer is marked on the firm plate and displacer weight can be measured by weighting of it.

- d2. Enter and validate the [SPAN]: the [LEVEL:%] value indicated on the display must equal 100.0%. If not, restart the procedure until very close to this value. See Appendix C.
- e. Press the \* button when [SAVE] is displayed to validate the [ZERO] and [SPAN] settings.
- f. To check if the specific gravity meter calibration has been correctly done, go to VIEW DATA menu, then [SG METER] to read values corresponding to low and high references.

## 7.5. MECHANICAL STOPS SETTING

### CAUTION:

This procedure is only possible if the [SG METER] function has been calibrated.

This procedure consists of setting the mechanical stops (adjusting screws) on the specific gravities of the process. Then, these adjusting screws are very helpful to perform a dry calibration (without fluid).

The two adjusting screws (114) are located on the sides of the case and are closed by two 1/8" NPT plugs (115). They are adjusted at factory if the specific gravity meter has been calibrated upon displacer type used.

- a. Open the access plug (107) on the right side of the case to look at the simulation mechanism. Remove plug (190) and the two 1/8" NPT plugs (115). Use a 5 mm hex wrench.
- b. Through this hole, to define REF L and REF H, use your finger to move the flexure (59) in the direction of the torque tube until the flexure touches the adjusting screw post (114). While maintaining contact, slide the flexure left or right along the surface of the screw post (Figure 18).

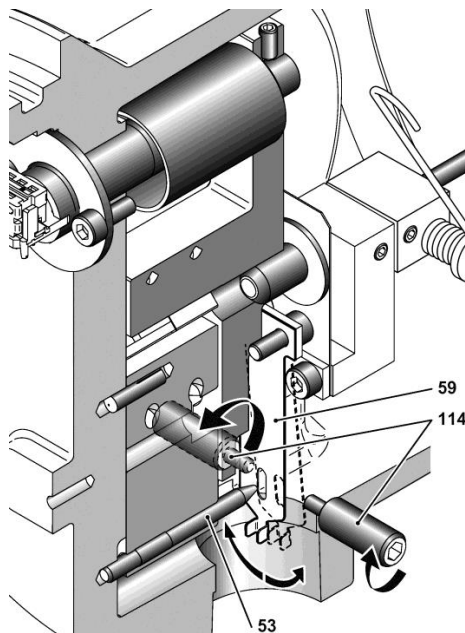

Figure18  
Setting of adjusting screws

- c. Perform the two adjusting screws (114) setting by reading the specific gravity value indicated by the specific gravity meter through VIEW DATA menu and SPECIFIC GRAVITY METER sub-menu.

### CAUTION:

Specific gravity value refresh requires exiting and entering again the SPECIFIC GRAVITY METER sub-menu.

- d. Enter VIEW DATA menu and SPECIFIC GRAVITY METER sub-menu.
- e. **LOW LEVEL REFERENCE [ZERO]**
  - e1. **Liquid application:**

Press the flexure (59) against the adjusting screw shoulder (114), which corresponds to the low level (opposite side to the displacer). While maintaining contact and using a 3 mm hex wrench, turn the adjusting screw until LCD displays the specific gravity value 0.0.
  - e2. **Interface application:**

Press the flexure (59) against the adjusting screw shoulder (114), which corresponds to the lowest specific gravity [LSG CALIB]. While maintaining contact and using a 3 mm hex wrench, turn the adjusting screw until LCD displays this specific gravity.

**f. HIGH LEVEL REFERENCE [SPAN]**

**f1. Liquid application:**

Press the flexure (59) against the adjusting screw shoulder (114) which corresponds to the high level (on displacer side). While maintaining contact and using a 3 mm hex wrench, turn the adjusting screw until LCD displays the value of process specific gravity [SG CALIB].

**f2. Interface application:**

Press the flexure (59) against the adjusting screw shoulder (114) which corresponds to the highest specific gravity [HSG CALIB]. While maintaining contact and using a 3 mm hex wrench, turn the adjusting screw until LCD displays this specific gravity.

**g.** Slowly move the flexure (59) from one shoulder (114) to the other (slowly to avoid displacer oscillations) and verify the value displayed. Correct adjustments if necessary.

**h.** Reinstall all plugs (107), (190), and (115).

## 7.6. TORQUE TUBE TEMPERATURE COMPENSATION

### 7.6.1. GLOBAL PURPOSE

The 12400 Series instrument includes a non-intrusive and integrated software temperature compensation of the torque tube from -210°C to +450°C.

There are two temperature sensors located in the sensor board and the main circuit board of the instrument.

Variation of torque tube Young modules over ambient and process temperatures shall be compensated to prevent any zero shift and span variation on very high or low process temperature applications.

The software module compensates these potential variations of Young modules that may happen in case of temperature difference between temperature saved during calibration procedure and current temperature (impacted by ambient and process temperatures).

This function is available on device revision Firmware 114 or later.

ValVue suite software is required to set this temperature compensation feature. Push-buttons and any HART handheld do not enable to activate and set this feature.

### 7.6.2. TEMPERATURE COMPENSATION ACTIVATION

Through ValVue suite software, the temperature compensation feature is enabled or disabled on the Advanced Setup menu.

- Change device mode to **Advance Setup** and go on the **Advanced Setup** tab.
- Activate the Torque Tube temperature compensation by clicking **TT Activation** checkbox.
- To define the expected process temperature, click the **Process Temperature** checkbox and enter the corresponding temperature value in degC.
- Validate by clicking on **Apply**.

The screenshot displays the ValVue 12400 - 12400 software interface. The 'Advanced Setup' tab is selected. The 'Torque Tube Compensation' section is highlighted with a red box, showing the following settings:

Field	Value
TT Activation	<input checked="" type="checkbox"/>
Process Temperature	<input checked="" type="checkbox"/> 100.0 degC

Other visible settings include:

- Tag Name: 12400
- Descriptor: GE - MASONIELAN
- Message: 12400 LEVEL - OIL/WATER TANK
- Date: 26 AUG 2009
- Final Assy Number: 0
- SIL2 Fault Timeout: 100
- SIL2 Configuration: SIL 2 Device
- Local User Interface:  Configure Enabled
- SG Meter Calibration: ZERO
- SG Calibration: 1.000
- SPAN
- Reset to Factory
- Alarms: Alarm Low 1 (10.00%), Alarm High 1 (90.00%), Alarm Hysteresis (0.49%)
- DO Switches: Switch #1 (Low Level\_1), Switch #2 (High Level\_1)
- Range: Level LRV (0.00), Level URV (100.00), Level Units (%), Zero Shift % (0.00), Reduced Span % (0.00)
- Controller Activation:

### 7.6.3. TEMPERATURE COMPENSATION SETTING

Through ValVue suite software, the temperature compensation parameters can be set on the Advanced Setup menu.

- a. On the Advanced Setup tab, click on **Database**.

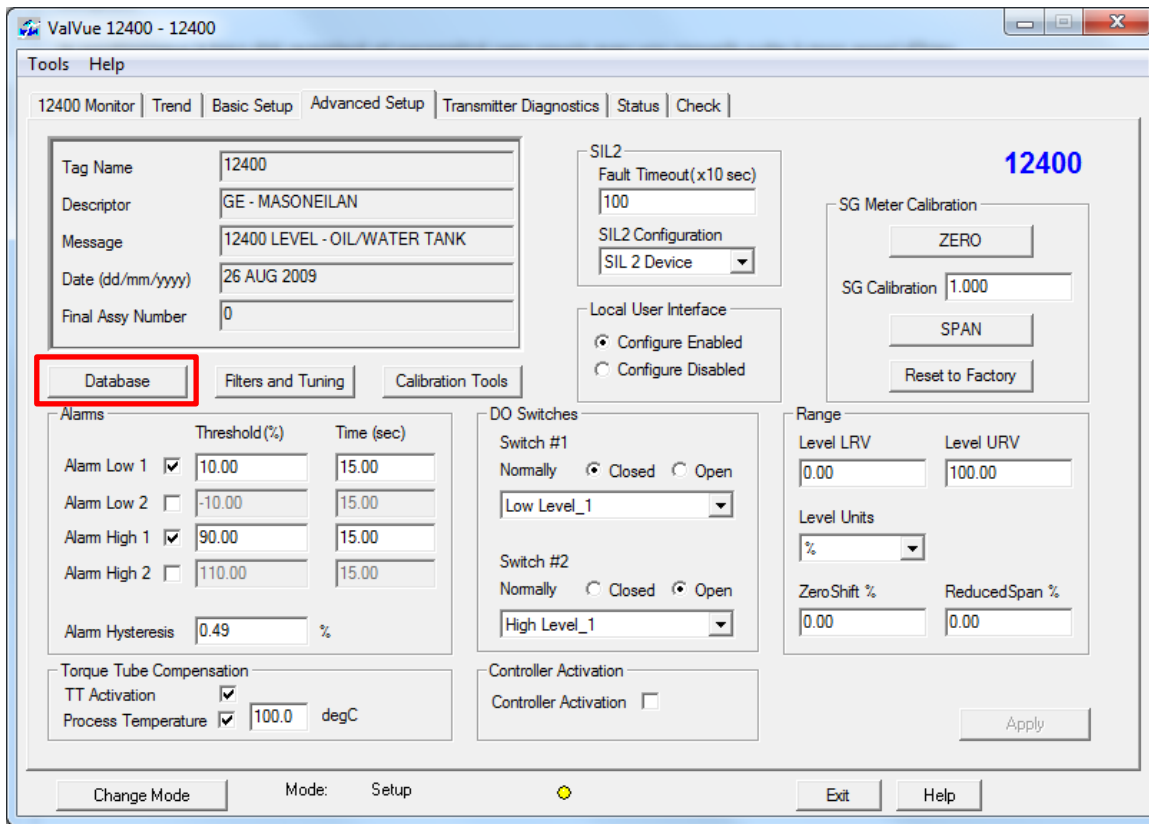

- b. Click on the arrow of the drop down list, located at the right of the **Torque Tube Matl.**

- c. Select the materials related to the torque tube and housing sub-assembly: Inconel/Carbon Steel, Inconel/St. Steel, St. Steel/St. St., Monel/Carbon Steel, etc.

In case of No Torque Tube setting, Inconel/Carbon Steel temperature compensation is applied by default.

- e. Validate by clicking on **Apply**.

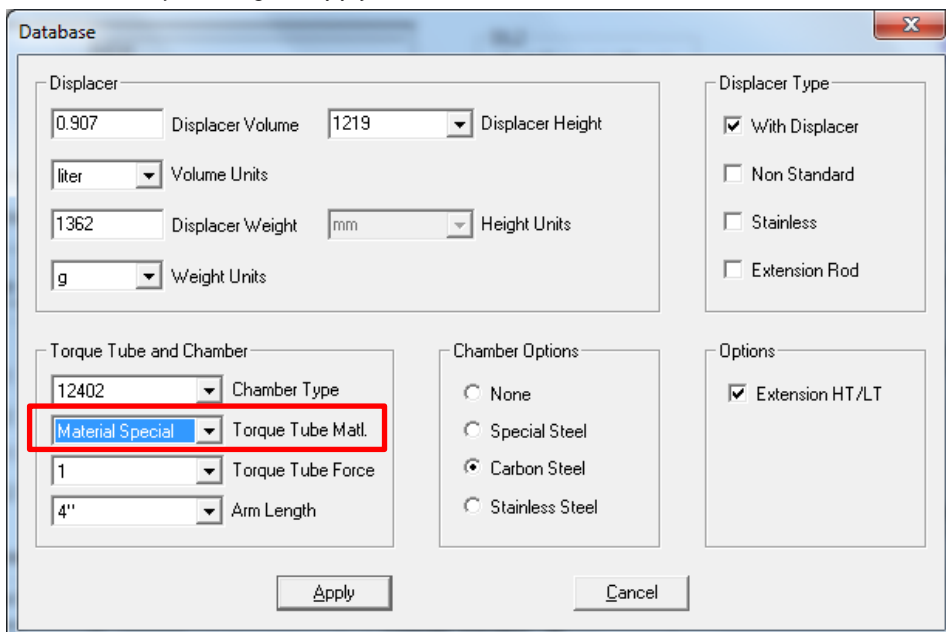



## 7.7. CONTROLLER FUNCTION (12410 MODEL ONLY)

### CAUTION:

The following instructions related to the Controller function shall be performed only if Coupling and Transmitter features have been previously adjusted. See Sections 7.1 to 7.6.

### IMPORTANT

The Controller function can be activated only if it has been ordered initially. You cannot add it later on site (see numbering system Section 3.2).

The 12410 model Level Controller is a Level measurement instrument which includes a built-in PID controller function to directly and locally control a level control loop. It has been specifically designed to retrofit pneumatic level control loops or enable an easy and cost-effective solution to perform a local and independent level control loop.

The controller function is available on device revision Firmware 113 or later.

The controller function is not included in the scope of the SIL certification. Only the transmitter function is SIL certified.

### 7.7.1. INSTRUMENTS INPUTS/OUTPUTS

- ◆ The 4-20 mA analog output signal, available on AO\_1 terminals, is the controller output signal generated by a PID algorithm based on error between the local setpoint and the level process variable. HART communication is available on AO\_1.
- ◆ The 4-20 mA analog output signal, available on the AO\_2 terminals, is the level or interface measurement signal. No HART communication.
- ◆ DO\_1 and DO\_2 terminals are two independent isolated digital switch outputs. They are user-adjustable and polarity sensitive.

### 7.7.2. CONTROLLER ACTIVATION

The activation of the controller function can be performed in the Advanced Setup menu through the push-buttons or ValVue suite software only.

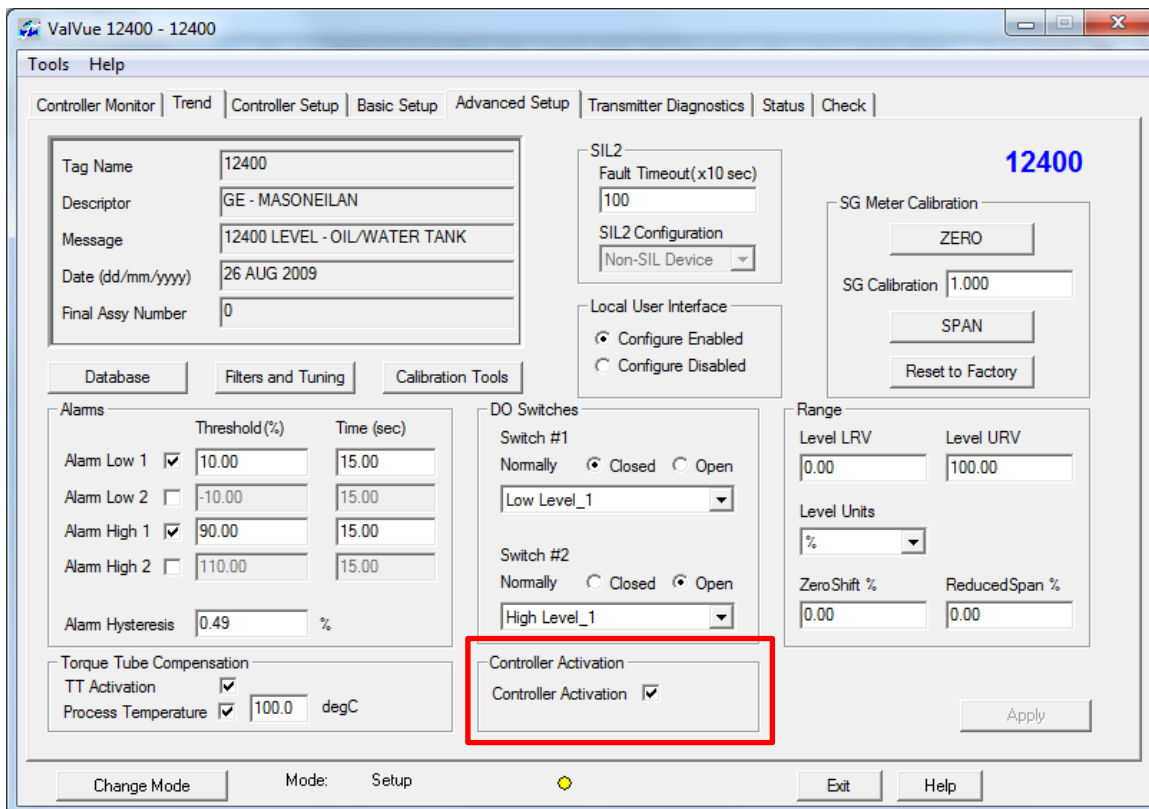

Activation through push-buttons (see Annex C):

- a. Change device mode to **Setup** mode and go to the **Advanced Setup** menu.
- b. By pressing two times the push-buttons +, go the Controller (**CTRL**) menu and press \* to enter.
- c. Activate or disable the Controller function.
- d. Leave the Advanced Setup menu to validate the new setting.

### 7.7.3. PID CONTROLLER STRUCTURE

The PID structure used is the **parallel** mode:

Two types of designs can be selected for the derivative action based on the error or on the process variable

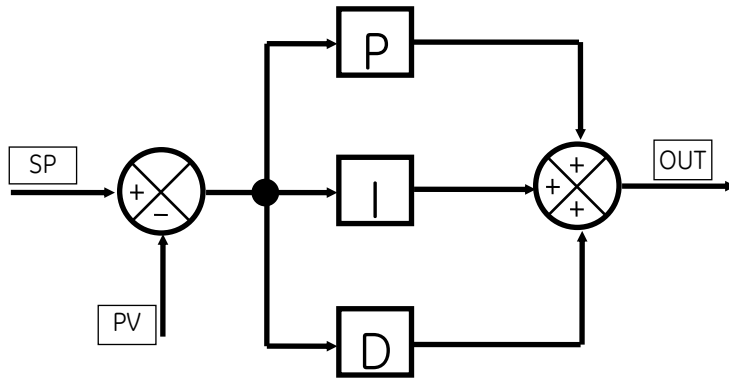

Derivative action is on the ERROR

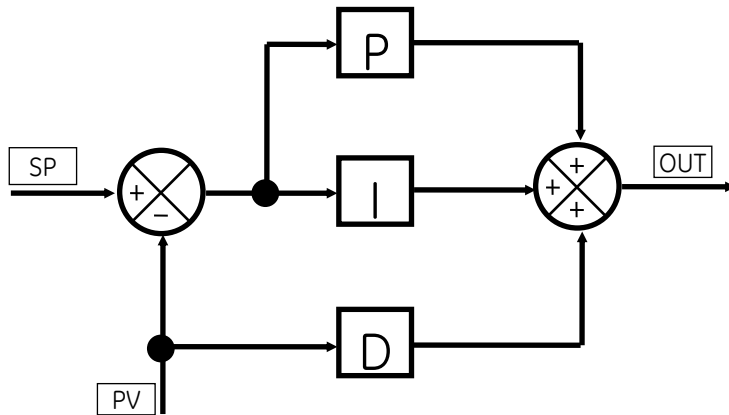

Derivative action on the Process Variable.

### 7.7.3. CONTROLLER SETUP

## IMPORTANT

The Controller set-up parameters can set by ValVue suit software only).

The Controller Setup tab enable to set all parameters related to the controller function: setpoint range and limits, PID parameters, configuration date and alarms. Please consult the on-line help for further information.

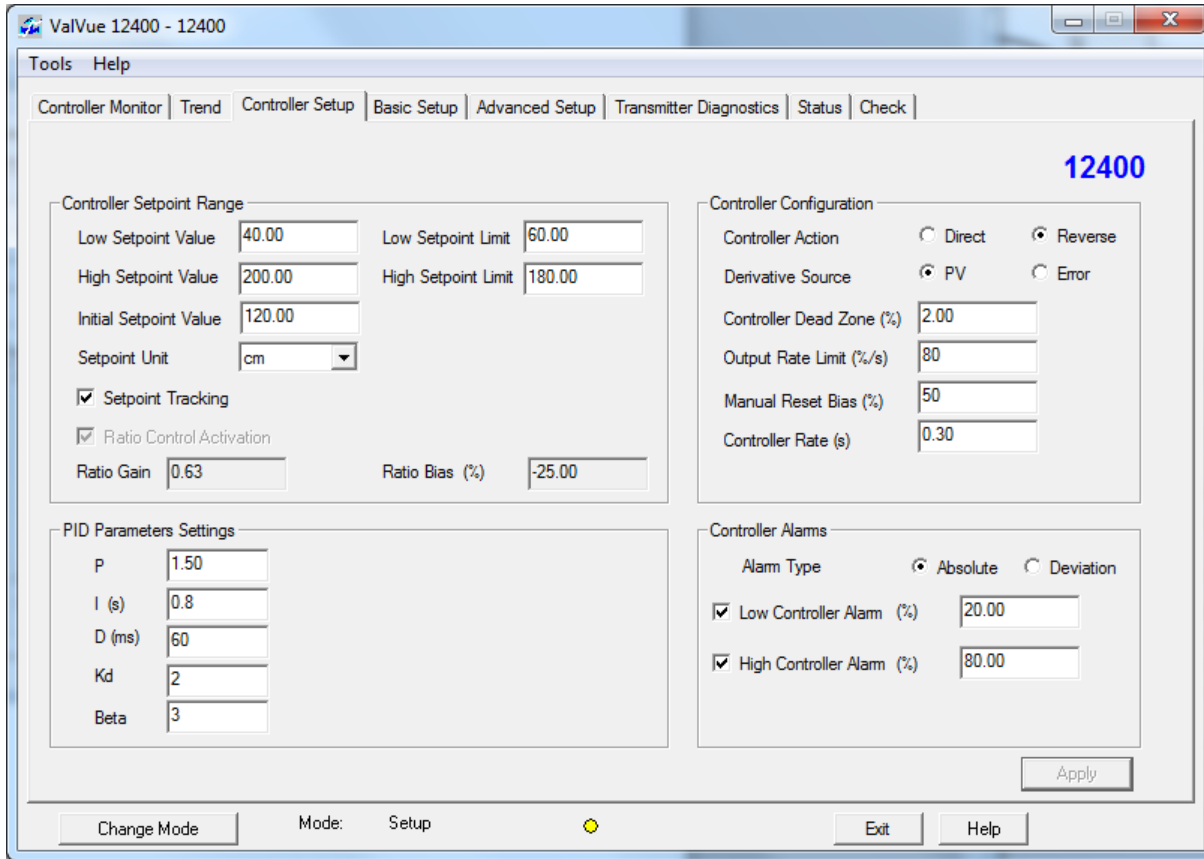

#### 7.7.3.1. Controller setup range

Low and High Setpoint Values	Desired lowest and highest controller setpoint values. These limits must be within 10% of the <i>Low and high Controller Alarm</i> values.
Initial Setpoint Value	first controller setpoint value when the instrument is power up.
Setpoint Unit	Use the pulldown to select the unit for use in the program. If the setpoint units do not match the level units, the <i>Ratio Control Activation</i> automatically activates
Setpoint Tracking	Click to enable setpoint tracking. When enabled, if the controller is changed from manual mode to normal mode, the setpoint is set equal to the current process variable
Ratio Control Activation	Automatically activated when setpoint and level measurement do not have the same unit or range. This feature enables the instrument to perform automatic calculations to compensate.
Ratio Gain and Ration Bias (%)	These two parameters are automatically calculated to convert controller setpoint range and units into level measurement range and units.

### 7.7.3.2. Controller configuration

Controller Action	Click either <i>Direct</i> or <i>Reverse</i> . Direct action means that the 4-20mA controller output increases when the process variable is greater than the setpoint when process variable (is lower than setpoint for Reverse action).
Derivative Source	Click either <i>PV</i> or <i>Error</i> . This determines whether calculations are based on process variable or error.
Controller Dead Zone (%)	Enter the percentage for the control dead zone. The controller output will remain unchanged as the error remains within this dead zone.
Output Rate Limit (%/s)	Enter a value to limit how fast the controller output can change.
Manual Reset Bias (%)	Enter the percentage for the controller bias during a reset.
Controller Rate (s)	Enter the value to define the time between the controller output is refreshed. The value shall be a multiple of 0.06. The instrument will do rounding automatically.

### 7.7.3.3. PID parameters settings

P	P is a dimensionless gain factor related to the proportioning action of the algorithm. It ranges from 0 to 50.
I (s)	The Integral time (or reset time) is the time constant of integral control. Higher values of I cause slower integral action. Common values are 0 to 100 (10 seconds). A value of zero disables integral action.
D (ms)	Derivative time or rate time is the time constant of derivative control expressed in milliseconds. It ranges from 0 to 5000 msec. A value of zero disables derivative action.
Kd	Differential gain used in PID controller for position. It ranges from 0 to 100.
Beta	Beta is a nonlinear dimensionless gain factor, ranging from -9 to 9. When beta is 0, the controller gain is linear. Otherwise the gain is the function of error. The larger the beta, the smaller the gain for small error.
Apply PID	Saves the configuration to the device.

### 7.7.3.4. Controller alarms

Alarm Type	<p>Click either:</p> <ul style="list-style-type: none"> <li>• <b>Absolute:</b> Determines that alarming is performed when the process variable go beyond the controller alarm values (exceeds for high alarm and go below for low alarm).</li> <li>• <b>Deviation:</b> Determines that alarming is performed when the difference between the process variable and the setpoint is greater the deviation value.</li> <li>• The alarm limits are entered in the same units as the process variable.</li> </ul>
Low and High Controller Alarms	Click the checkbox and enter a value for the appropriate level (s). These limits must be within 10% of the <i>High Setpoint</i> value and <i>High Setpoint</i> value, respectively. See PID Controller Setpoint Range.

## 7.7.4. CONTROLLER MONITOR

Monitor of the controller function is performed in the **Controller Monitor** tab. This screen only appears if Controller Activation is selected on the Advanced Setup Screen.

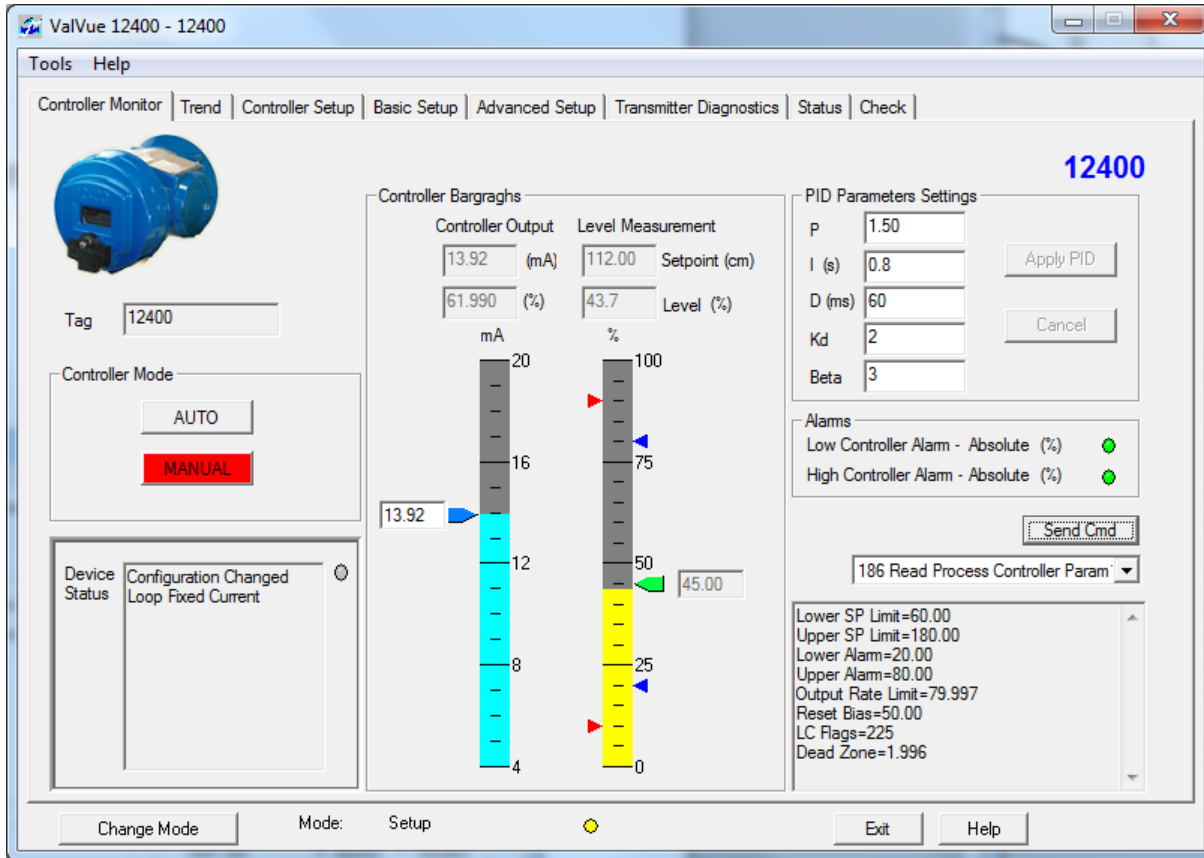

The 12400 Controller Monitor screen provides at a glance access to 12400 PID operation. It includes the following functionalities:

- View Controller Bargraphs with controller output on the left bargraph, and process variable and controller setpoint on the right bargraph.
- Set Controller Setpoint (in Normal mode) or Controller Output (in Setup mode)
- Read Device Status
- Change Tag Name
- Set PID Parameters
- View activation of PID Alarms
- Send HART Command
- Change the Controller Mode

This screen allows to change the 4-20mA output signal (when in MANUAL mode) by dragging the controller output indicator or entering a detailed value, or to change the process setpoint (in AUTO mode) by dragging the setpoint indicator (right bargraph) or entering a specific value.

ValVue 12400 - 12400

Tools Help

Controller Monitor | Trend | Controller Setup | Basic Setup | Advanced Setup | Transmitter Diagnostics | Status | Check



Tag: 12400

Controller Mode: **AUTO** (MANUAL)

Device Status: Configuration Changed

### Controller Bargraphs

Controller Output	Level Measurement
10.68 (mA)	109.41 Setpoint (cm)
41.750 (%)	43.6 Level (%)

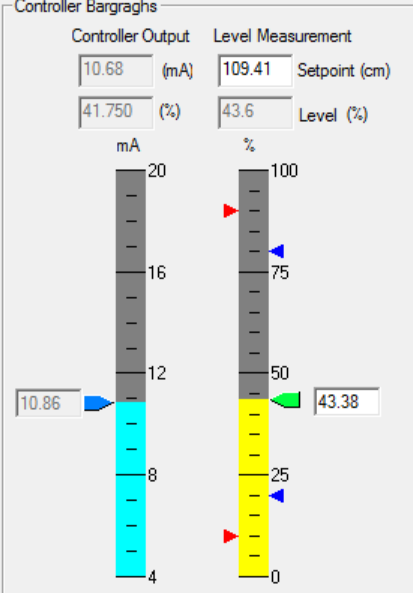

### PID Parameters Settings

P	1.50	Apply PID
I (s)	0.8	
D (ms)	60	Cancel
Kd	2	
Beta	3	

### Alarms

- Low Controller Alarm - Absolute (%)
- High Controller Alarm - Absolute (%)

Send Cmd

186 Read Process Controller Param

Lower SP Limit=60.00  
Upper SP Limit=180.00  
Lower Alarm=20.00  
Upper Alarm=80.00  
Output Rate Limit=79.997  
Reset Bias=50.00  
LC Flags=225  
Dead Zone=1.996

Change Mode Mode: Normal  Exit Help

# 8. Safety manual for SIL applications

## 8.1. RELEVANT STANDARDS

**a. IEC 61508 (also available as DIN EN)**

Functional safety of electrical/electronic/programmable electronic safety-related systems

**b. IEC 61511 (also available as DIN EN)**

Functional safety - safety-instrumented systems for the process industry sector

## 8.2. TERMS AND DEFINITIONS

FIT	Failure In Time ( $1 \times 10^{-9}$ failures per hour)
FMEDA	Failure Mode Effect and Diagnostic Analysis
HFT	Hardware Fault Tolerance
Low Demand mode	Mode, where the frequency of demands for operation made on a non-safety related system is no greater than twice the proof test frequency
MTTR	Mean Time To Repair
$PFD_{avg}$	Average Probability of Failure on Demand
Safety Accuracy	The measurement error that occurs due to component degradation and failure during the useful life of an instrument.
SFF	Safe Failure Fraction, summarizes the fraction of failures, which leads to a safe state and the fraction of failures which will be detected by diagnostic measures and lead to a defined safety action
SIF	Safety Instrumented Function
SIL	Safety Integrity Level
SIS	Safety Instrumented System – Implementation of one or more Safety Instrumented Function. A SIS is composed of any combination of sensor(s), logic solver(s), and final element(s).
Type A component	"Non-Complex" component (using discrete elements); for details see IEC 61508-2
Type B component	"Complex" component (using micro controllers or programmable logic); for details see IEC 61508-2
$\lambda_{sd}$	Rate for Safe Detected failure
$\lambda_{su}$	Rate for Safe Undetected failure
$\lambda_{dd}$	Rate for Dangerous Detected failure
$\lambda_{du}$	Rate for Dangerous Undetected failures

### 8.3. SAFETY REQUIREMENTS

#### 8.3.1. PROBABILITY OF FAILURE ON DEMAND (PFD<sub>AVG</sub>)

This table reflects the achievable Safety Integrity Level (SIL) depending on the mean provability of failure on demand. The specified failure tolerances in this case apply to a safety function operated in the Low Demand mode.

Safety Integrity Level (SIL)	PFD <sub>avg</sub> with Low Demand mode
4	$\geq 10^{-5}$ to $< 10^{-4}$
3	$\geq 10^{-4}$ to $< 10^{-3}$
2	$\geq 10^{-3}$ to $< 10^{-2}$
1	$\geq 10^{-2}$ to $< 10^{-1}$

#### 8.3.2. SAFETY INTEGRITY OF THE HARDWARE

This table shows the achievable Safety Integrity Level (SIL) depending on the proportion of non-dangerous failures (SFF) and the fault tolerance of the hardware (HFT) for safety-related type B subsystems.

Proportion of non-dangerous failures (SFF)	Fault tolerance of the hardware (HFT)		
	0	1	2
< 60%	Not permitted	SIL 1	SIL 2
60% - < 90%	SIL 1	SIL 2	SIL 3
90% - < 99%	<b>SIL 2</b>	SIL 3	SIL 4
$\geq 99\%$	SIL 3	SIL 4	SIL 4

### 8.4. SAFETY CHARACTERISTICS

#### 8.4.1. ASSUMPTIONS

The specified characteristics are applicable under the following assumptions that have been made during the FMEDA.

- The instrument is being **used as a transmitter** and the controller function is disabled (if applicable).
- **The instrument must be configured as a SIL 2 device with failsafe position defined as Fail Low (<3.6 mA).**
- In case of custom displacer, displacer weight must be lower the following rule:

$$\text{Displacer Weight (gr)} < 1600 \times \text{TT force} \times 4 / \text{arm length}$$

Torque tube force = 1, 2 or 4

Arm length = 4", 8", 16" (side vessel) or other

i.e.  $1600 \times 1 \times 4 / 4 = 1600$  gr for a standard displacer and single force torque tube



- The repair time (MTTR) after a device has failed is 24 hours.
- The architectural constraint type for the 12400 Series level instrument is B (Low demand).
- The hardware fault tolerance of the device is 0.
- To avoid unwanted or unauthorized modification, the set parameters must be protected. Therefore, **the hardware lock jumper must be set in the secure (locked) position.**
- Proof test interval:  $\leq 1$  years.
- Safety accuracy: 2% of full span.
- Only a single component failure will fail the entire 12400 Series level instrument.
- Failure rates are constant, wear-out mechanism is not included.
- Propagation of failures is not relevant.
- All components that are not part of the safety function and can not influence the safety function (feedback immune) are excluded.
- The stress levels are average for an industrial environment and can be compared to the Exida profile 3 with temperature limits within the manufacturer's rating. Other environmental characteristics are assumed to be within manufacturer's rating.
- A practical fault test can demonstrate the correctness of the failure effects during the FMEDA and the diagnostic coverage provided by the online diagnostics.
- The HART protocol is only used for setup, calibration and diagnostics purposes, not for safety critical operation.
- The application program in the logic solver is constructed in such a way that Fail High and Fail Low failures are detected regardless of the effect, safe or dangerous, on the safety function.
- Materials are compatible with process conditions.
- The device is installed, calibrated and maintained per manufacturer's instructions.
- External power supply failure rates are not included.
- Worst-case internal fault detection time is one hour.

#### 8.4.2. HARDWARE AND FIRMWARE REVISIONS SUITABLE FOR SIL APPLICATIONS

Hardware revision must be revision 1 or later.

Firmware revision must be revision 1.1.2 or later.

#### 8.4.3. HARDWARE LOCK JUMPER ADJUSTMENT

The lock jumper function allows or disables any setting parameter changes. It is located in the front view of the instrument head, behind the main cover. **The hardware lock jumper must be set in the secure (locked) position to be used as a SIL 2 instrument.**

When set to the secure position, shorting the two-pin header, access to Setup and Clear Error modes are not permitted by the local interface or by the remote HART communication. It is not allowed to write any new data into the instrument memory. Pushbuttons, ValVue and any HART® handheld are locked out, except to read data (normal, view data and view errors menus). In such case, LOCK message is indicated on LCD display when the user presses a button.

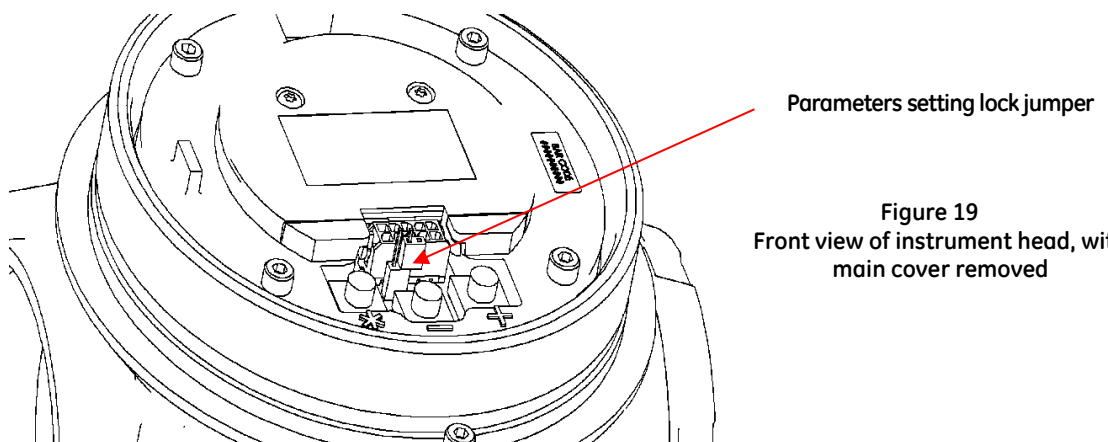

Figure 19  
Front view of instrument head, with  
main cover removed

#### 8.4.4.CHARACTERISTICS

Device Level (SIL)	Unit type	HFT	$\lambda_{sd}$	$\lambda_{su}$	$\lambda_{dd}$	$\lambda_{du}$	SFF
12400 Series Digital Level Instrument	B	0	0 FIT	192 FIT	575 FIT	72 FIT	91.4

#### 8.5. SAFETY FUNCTION

The Safety Function of the 12400 series Digital Level Transmitter must be to monitor the level or interface of a liquid and transmit a 4-20 mA analog signal within the measurement safety accuracy. It includes the whole hardware and software measurement chain from the displacer through the torque tube and the electronic board to the primary analog output signal AO\_1.

#### 8.6. PROOF TEST

According to section 7.4.3.2.2 f of IEC 61508-2, proof tests must be undertaken regularly to reveal dangerous faults which are undetected by diagnostic tests. This means that it is necessary to specify how dangerous undetected faults, which have been noted during the FMEDA, can be detected during proof testing

The test intervals necessary for this purpose are defined in the calculation of the respective safety loop.

Tests must be conducted by the manufacturer or an authorised person duly trained on the instrument and SIS operations.

#### Recommend Proof test

Step	Action
1	Bypass the safety function and take appropriate actions to avoid a false trip and any safe actions against dangerous atmospheres.
2	Inspect the instrument for dirty or clogging parts, adequate wiring, correct mounting of end connections and other physical damage.
3	Examine the torque tube and the displacer to detect corrosion or leaks (replace if necessary).
4	Observe the tightening torques for the nuts and studs.
5	Check the Bias spring position is correct.
5	Use HART communications to retrieve any diagnostics and take appropriate action.
6	Send a HART command to the transmitter to go to the high alarm current output and verify that the analog current reaches that value. This tests for compliance voltage problems such as a low loop power supply voltage or increased wiring resistance.
7	Send a HART® command to the transmitter to go to the low alarm current output and verify that the analog current reaches that value. This tests for possible quiescent current related failures.
8	Perform a five-point calibration check of the displacer and transmitter over the full working range using the process fluid(s). If the calibration check is performed by any means other than the fluid(s) acting on the displacer, this proof test will <u>not</u> detect any failures of the displacer.
9	Lock the settings by adjusting the hardware lock jumper position
10	Remove the bypass and otherwise restore normal operation.

# 9. Maintenance

## DANGER

1. Do not remove covers (281, 104 and 107) from 12400 case without prior reading of ATEX instruction manual GEA19100 (400152322). See figures 12 and 13.
2. The following actions may require opening the mechanism compartment. Before any new commissioning, check that all covers and the plug are correctly mounted with gaskets/O-rings in good condition.
3. Use only Masoneilan original parts. Pay particular attention to the plug (90) which includes a compressible gasket (192).
4. Read carefully instructions from the ATEX instruction Manual GEA19100 (400152322).

### 9.1. REMOVAL OF 12400 CASE FROM TORQUE TUBE (FIGURES 1, 12, 13, 15 & 21)

- a. Switch off power supply. Unscrew safety screw (106) until it disengages from the case and remove the cover (104) of the connection compartment. Disconnect supply wires from terminals (90).
- b. Remove cover (107) of the mechanism compartment. Remove the spring arm (242) from the pin (243) on the beam to disengage and relax it.
- c. Using a 2.5 mm hex wrench, loosen screw (62) to uncouple the beam (54) from the torque rod.
- d. While holding the case to prevent it from falling, loosen the four screws (121), using a 5 mm hex wrench, and remove them along with the washers (122). Remove the case by pulling it along the axis of the torque tube while being careful to prevent from any deformation of the coupling flexure (70).
- e. If the original case or an identical one is reinstalled on the same torque tube, do not remove the coupling flange (116) from the torque rod. Also, do not disconnect the coupling flexure subassembly (70). As an alternative, loosen screws (119) using a 1.5 mm hex wrench and remove the coupling flange-flexure sub-assembly (116-70).
- f. If the torque tube is not dedicated to 12400 instrument, remove the DLT case adapter kit, if necessary. This kit includes a flange, a gasket, and screws, (see Figure 21).

### 9.2. INSTALLATION OF 12400 CASE ON A TORQUE TUBE (FIGURES 1, 12, 13, 15, 20 & 21)

#### 9.2.1. ON A 12200/300/400 SERIES TORQUE TUBE

- a. Mount the torque tube (137) on a support. The knife pivot at the back of the tube must be oriented toward the top.
- b. On the transmission rod (138), mount the bias assembly (241).
- c. On the transmission rod (138), mount the coupling S/A (75) including flange (116), coupling flexure S/A (70) [incl. flexure (71), pin (72) and washer (73)], flange (117) and its two loosened screws (118) (see figure 19).
- d. Attach a weight to the torque arm equivalent to that of a displacer half immersed in a 1.4 specific gravity liquid. The target is the coupling S/A and bias S/A to be vertical for mid S.G.1.4. See Section 7.1.b1.
- e. Position the sub-assembly vertically on the rod so that the distance between the coupling flexure (71) and the torque tube flange is 59.5 mm  $\pm$ 0.5 (see figure 20). Firmly tighten this sub-assembly to the rod, using the two lateral screws (119).
- f. Put the bias at 1 mm from the coupling S/A, align the bias S/A with the coupling S/A and tighten it on the rod with the two lateral screws (244).

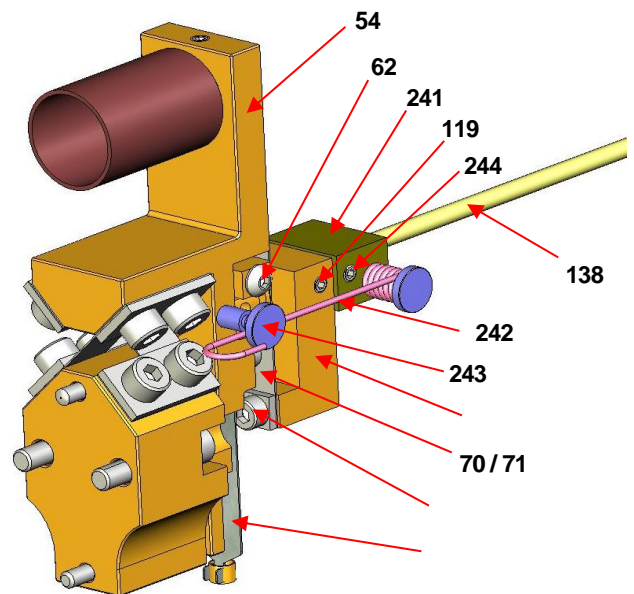

Figure 20  
Adjustment of Coupling Flexure t (71)  
On Coupling Flange (116)

- g. Verify that the screw (62) on the beam (54) is loose.
- h. Position the case correctly oriented toward the front and in line with the axis of the torque tube.
- i. Slide the case into the torque tube flange while observing through the side opening that the pin (72) is inserted into the beam coupling end. Use a flat tool to easily backup the coupling flexure (71).
- j. When the case is in contact with the torque tube flange, verify that the beam is free to rotate by placing your finger on the flexure (59) through the lower 3/4"NPT hole.
- k. Fasten the case with four screws (121) and washers (122). Firmly tighten.
- l. Verify again that the beam is free to rotate and that the coupling flexure (71) is not deformed. The coupling on the beam (54) is tightened later.

**Note:** At this point, if instrument service conditions are well defined, refer to Section 7 for instrument setting, coupling to the torque tube and setting the bias block S/A.

### 9.2.2. ON A 12120 OR 12800 SERIES TORQUE TUBE (FIGURE 21)

The 12400 instrument can be mounted on different types of existing torque tubes. Kits including flange, gasket, and screws are provided for the adapter tubes. However, due to the bias block S/A (241) implemented on 12400 SIL design, mounting and assembly of a 12400 head with SIL design on a 12120/12800 torque tube cannot be performed.

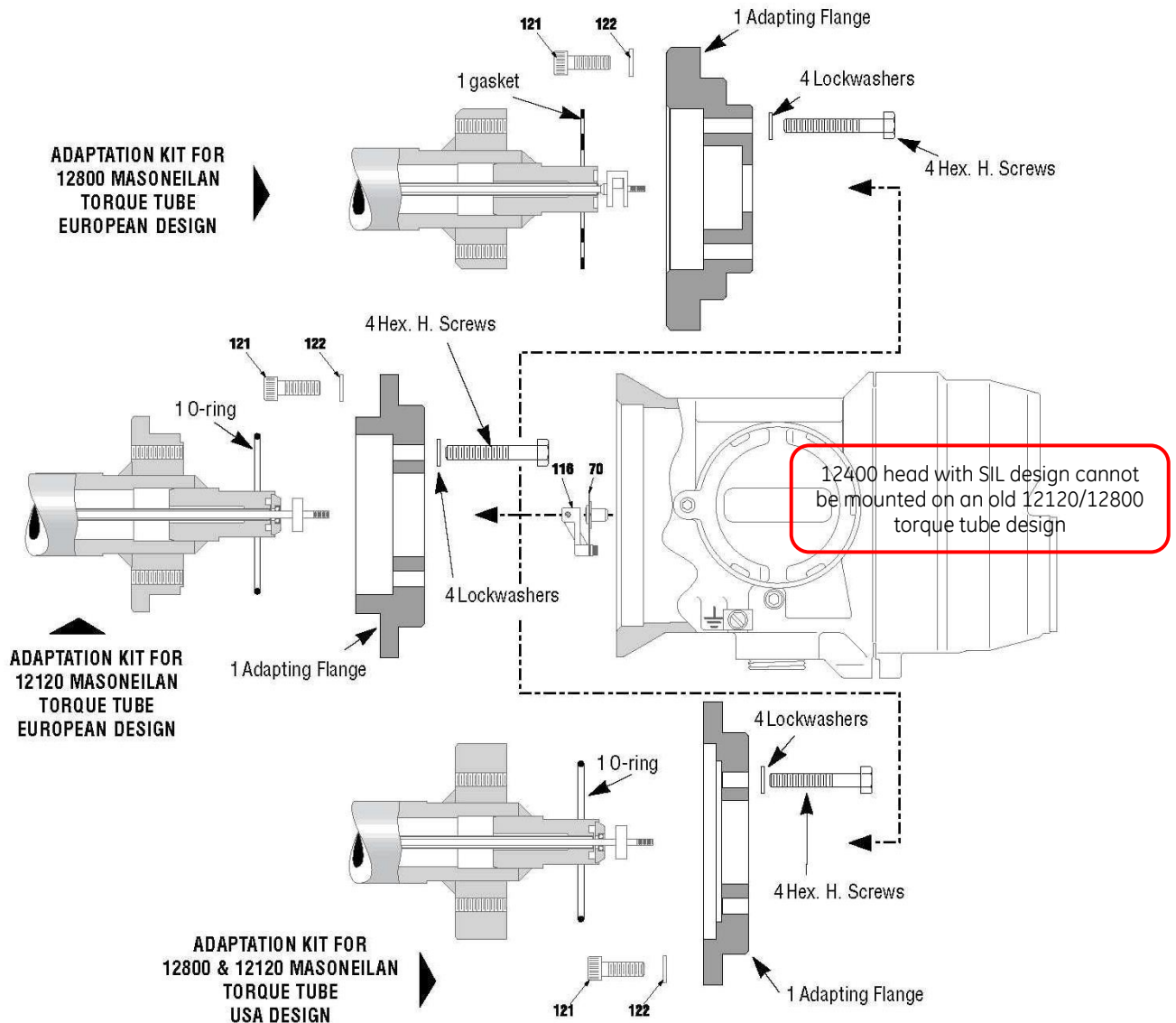

Figure 21 - Adaptation on 12800/12120 torque tube

### 9.3. REMOVAL OF 12400 CASE AND TORQUE TUBE SUB-ASSEMBLY (SEE FIGURES 22 & 23)

#### CAUTION:

To remove the displacer, the torque arm must be removed. When the two arm screws (133) are loosened, hold the torque arm so as not to damage the torque tube (Figure 22).

- a. Switch off power supply.
- b. For instruments with a displacer chamber, close isolation valves, and purge the chamber.
- c. Remove the upper flange (146) and blind flange (144).
- d. Lower the torque arm (135) and unhook the displacer (130). A hook-shaped 3 mm steel wire facilitates unhooking and holding of the displacer. The wire may be inserted through the clevis hole.
- e. Remove the two torque arm screws (133) and remove the torque arm (135) from the chamber.
- f. Remove the displacer from its chamber (131) or tank.
- g. Be sure that requirements for instruments installed in explosive areas are strictly followed. Remove screw (106) from connection compartment and unscrew cover (104). Disconnect supply electrical wires and other equipment from terminals (90).
- h. Remove nuts (142) holding the torque tube subassembly and slide the subassembly out of the mechanism chamber.

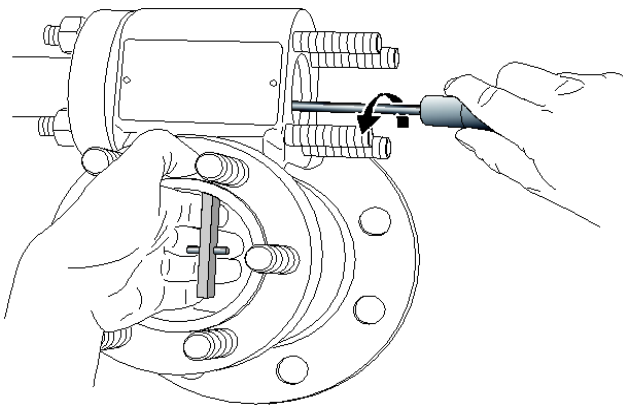

Figure 22

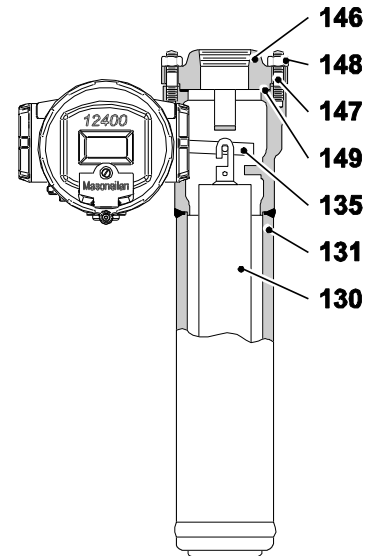
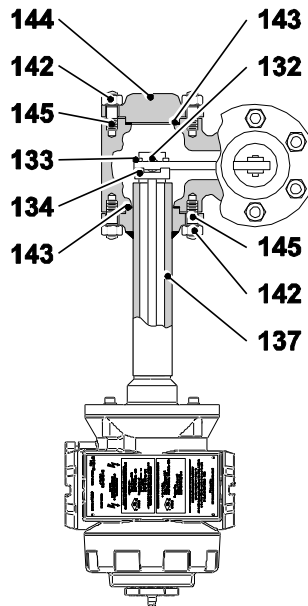

Figure 23

PARTS REFERENCE			
130	Displacer	143	Gasket
131	Displacer chamber	144	Blind flange
132	Knife of torque tube	145	Stud
133	Torque arm screw	146	Upper flange
134	Torque arm screw block	147	Upper flange stud
135	Torque arm	148	Upper flange stud nut
137	Torque tube housing S/A	149	Upper flange gasket
142	Stud nut		

## 9.4. MOUNTING OF DLT CASE AND TORQUE TUBE SUB-ASSEMBLY (FIGURE 24)

### CAUTION:

The following procedure is valid only if the coupling between beam and torque rod has already been adjusted for the required mounting direction (see Section 7.1).

The case mounting direction for which the coupling has been made may be identified as follows:

When the case is mounted and coupled to the torque tube (without torque arm or displacer), the tip of the conical pin (53) is aligned with one side of the oval hole in the flexure (59).

- ◆ **Left mounting: see figure 24a**
- ◆ **Right mounting: see figure 24b**

For installation, reverse the procedure outlined for removing a DLT case and torque tube sub-assembly (section 9.3). It is recommended that new gaskets (143 -149) be used when installation is performed (see figure 22).

*NOTE: If the coupling does not match the mounting direction, verify that the screw (62) is loose and pin (72) is free to rotate in the coupling end of the beam (54) before hooking the displacer on the torque arm (135). Continue by performing operations **g** to **i** in Section 9.5, unless the instrument is already prepared and calibrated for the specific application required by the customer. In such a case, however, it is recommended to check the adjustments of the specific gravity meter function, adjusting screws, and the calibration, before putting the instrument in service.*

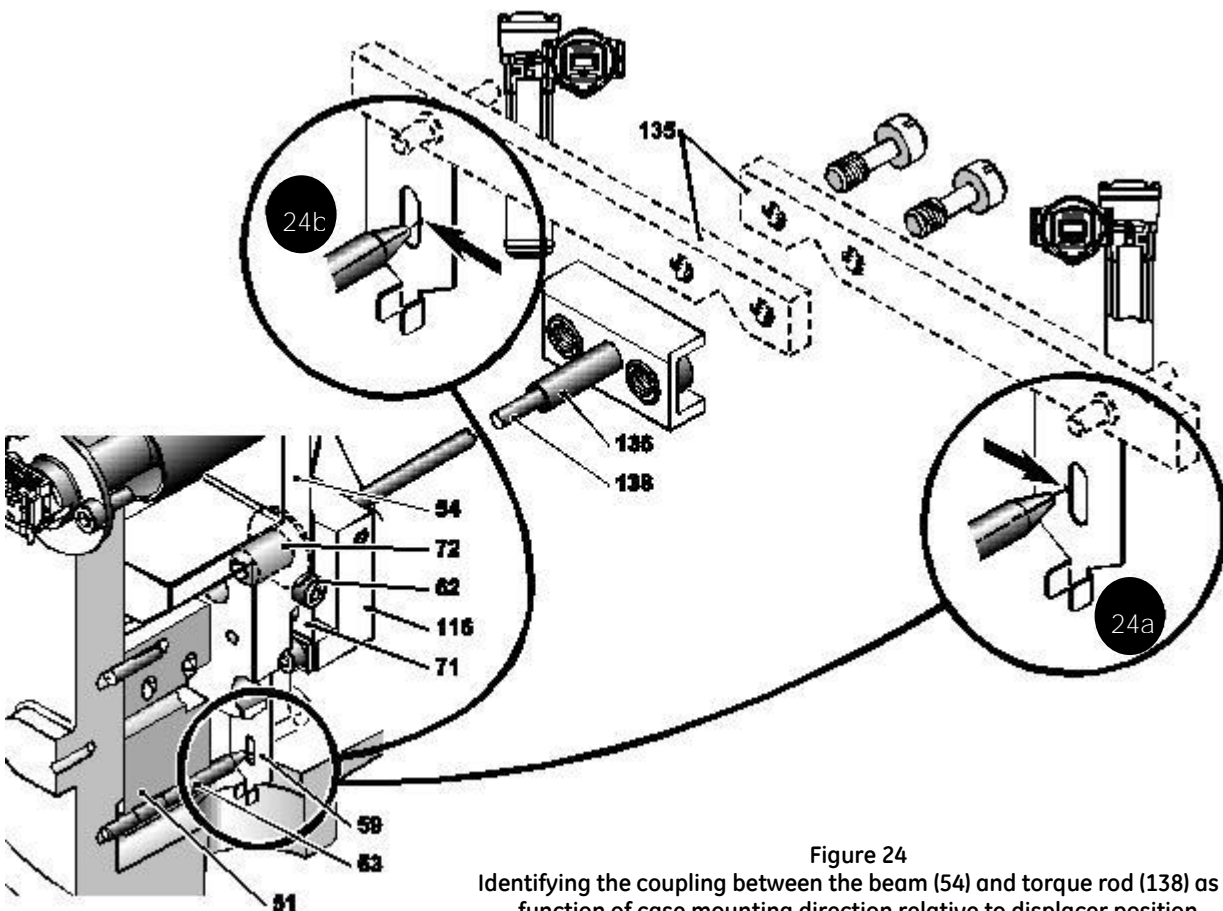

Figure 24  
Identifying the coupling between the beam (54) and torque rod (138) as a function of case mounting direction relative to displacer position

## 9.5. REVERSE INSTRUMENT CASE MOUNTING POSITION VERSUS TO DISPLACER POSITION (LEFT OR RIGHT MOUNTING) (FIGURES 7, 12 13, 20, 21 and 23)

- a. Follow instructions in Section 9.3 — Removing a DLT case and torque tube sub-assembly.
- b. Install the case/torque tube subassembly on the opposite side of mechanism chamber in place of flange (144) and open the cover (107) of the mechanism compartment. It is recommended that you install a new gasket (143) when reassembling.
- c. Using a 2.5 mm hex wrench, loosen the screw (62) of beam (54) to uncouple it from the torque rod.
- d. Replace the displacer in the chamber (131) or in the tank and hold it temporarily with a 3 mm steel hook.
- e. Insert the torque arm (135) into the mechanism chamber and assemble it to plate (134) with two screws (133).
- f. Lower the free end of the torque arm (135) and hook the displacer (130). Reassemble the top flange (146) and blind flange (144) using new gaskets (149 & 143).
- g. Open the cover (255) located in front of the instrument to gain access to the pushbuttons (260).
- h. Enter the BASIC SETUP menu then [CONFIG] and select the required configuration data corresponding to the new instrument position.
- i. Perform the coupling adjustment according to Section 7.1. If necessary, calibrate the specific gravity meter function and set adjusting screws per Sections 7.4 and 7.5. Proceed with calibration following Section 7.3.

**Note:** *The specific gravity meter function and the adjusting screws are features offered by the instrument. They enable a user to perform simulations that ease calibration in situations such as no liquid in low level when special interface displacers are used and for calibration with or without liquid in case of a level interface application using a standard displacer. If such conditions are not present, these adjustments are optional.*

## 9.6. REPLACEMENT OF ELECTRONIC AND MECHANICAL COMPONENTS

### CAUTION:

Replacement of the main electronic module, terminal board, sensor S/A or mechanism S/A must be performed using high accuracy tools and requires the instrument head to be returned to a GE's Operations.

If the actions done according to Section 10 failed to correct a default, please contact our local After-Sales Department.

If After-Sales support does not enable the device to successfully operate, replacement of a component may be required. In such case and after approval by our After-Sales Department, remove the 12400 case from torque tube following instructions given in Section 9.1 and ship it to indicated address.

### CAUTION:

Parts which constitute the mechanism subassembly (50), including elements (51 to 62) are assembled at the factory using high precision tools that guarantee highly accurate positioning, which is required to achieve specified performance. Never disassemble these parts unless a malfunction occurs. The whole sub-assembly must then be replaced or returned to the factory for rebuild.

# 10. Troubleshooting

## 10.1. NO SIGNAL

- ◆ Check connection wires to 12400 Series instrument.
- ◆ Check polarities of the connection wires.

## 10.2. EXISTING SIGNAL BUT NOTHING ON LCD DISPLAY

- ◆ The electronic module might be damaged and must be replaced at factory.

## 10.3. STEADY SIGNAL, NO CHANGE WHEN LEVEL VARIES

- ◆ In case of external mounting (see Section 4.2.1), check that displacer lock up in the displacer chamber, made for transportation purpose, has been removed.
- ◆ Check the instrument is not in FAILSAFE mode.
- ◆ Check the device is in NORMAL operating mode (alternating display of signal and level variable).
- ◆ Check correct coupling between transmission rod and mechanism sub-assembly by moving flexure (59), which allows simulating a level change.
- ◆ Check that the correct supply voltage is applied to terminal blocks of main analog output connections (AO\_1).

## 10.4. OUTPUT SIGNAL DIFFERS FROM VALUE DISPLAYED ON LCD

**WARNING:**  
FULL COMPLIANCE WITH STANDARDS REQUIREMENTS RELATED TO INSTRUMENTS INSTALLED  
IN HAZARDOUS AREAS MUST BE ENSURED.

- ◆ Check the load resistance is compliant with Section 5.4.5 and the power supply applied to main analog output signal is greater than 10 VDC.
- ◆ Insert a reference milliamp meter in series with the 4-20 mA signal loop.
- ◆ To recalibrate the internal milliamp meter, enter the [VAR SET] sub-menu via the ADVANCED SETUP menu (see Appendix C).
  - Enter into [MA LOW:mA]. Decrease or increase value (ranges from 2900 to 3500 by increment one) until the reference milliamp meter indicates 4.000mA (see Appendix C).
  - Enter into [MA HI:mA]. Decrease or increase value (ranges from 2900 to 3500 by increment one) until the reference milliamp meter indicates 20.000mA (see Appendix C).
  - Enter into [SIG GENE] via the ADVANCED SETUP menu to generate various output signals and check the current signal versus the reference milliamp meter (see Appendix E).



## 10.5. NO HART® COMMUNICATION

### DANGER:

FULL COMPLIANCE WITH STANDARDS REQUIREMENTS FOR INSTRUMENTS INSTALLED IN HAZARDOUS AREAS MUST BE ENSURED PRIOR TO ANY MAINTENANCE ACTION.

- a. Check the load resistance complies with Section 5.4.5 and is above 220 Ohms. Check the 12400 terminal board voltage is equal or greater than 10 V.
- b. If this is not the case, add a resistance greater than 220 Ohms in series on the loop.
- c. Check the electrical noise of the 4-20 mA loop complies with HART communication usage (see note).
- d. Check the position of the hardware lock jumper located in the front view of the instrument head, behind the main cover. The lock jumper function allows or disables any change of setting parameters. When set to the secure position, shorting the two-pin header, Setup and Clear Error are not permitted by the local interface or by the remote HART communication. It is not allowed to write any new data into the instrument memory. Pushbuttons, ValVue and any HART® handheld are locked out, except to read data (normal, view data and view errors menus). In such case, LOCK message is indicated on LCD display when the user presses a button.

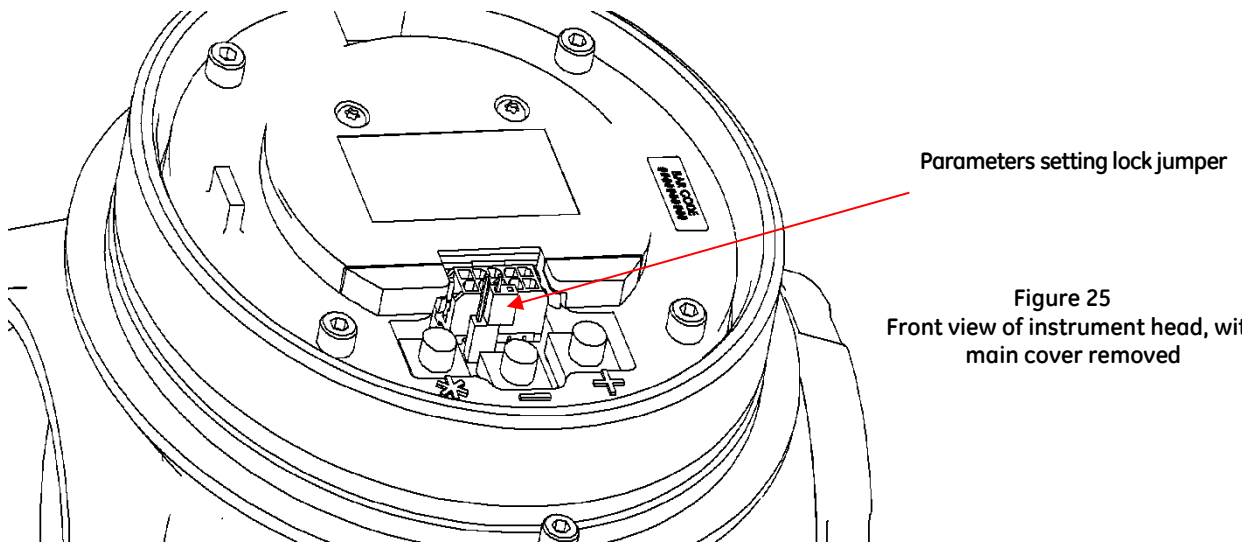

Figure 25  
Front view of instrument head, with  
main cover removed

- e. Check the wiring capacitance versus length (see note).
- Note: these data are given in the HART FSK physical layer specifications.

## 10.6. OUTPUT SIGNAL DOES NOT MATCH WITH THE LIQUID LEVEL (LINEARITY ISSUE)

- a. Check the calibration parameters, in particular [MA LOW:mA], [MA HI:mA], [Z SHIFT:%] and [R SPAN:%].
- b. Check the potential faults displayed into the VIEW ERROR menu and clear the errors with [CLR ERR] function (see Appendixes A and G).
- c. Check that the torque arm is horizontal without displacer.
- d. Check the displacer does not touch chamber bottom or inner sides.
- e. If mid-level can be generated or simulated, check coupling or do a new coupling according to Section 7.1. Caution, a new coupling requires a new zero and span calibration of the transmitter and the specific gravity meter.
- f. Recalibrate the transmitter according to Section 7.3.
- g. If the problem remains, contact our After-Sales Department.

## 10.7. VIEW ERROR DIAGNOSTICS MESSAGES

Diagnostic messages are viewed with VIEW ERROR from the SETUP Mode Menu or from NORMAL Mode Menu. The VIEW ERROR menu item allows you to read the current status information.

To clear the error messages, press \* at CLR ERR on either the SETUP or NORMAL mode menus.

Exiting from the VIEW ERR menu returns to the previous menu.

**Table - Error and Warning Messages**

Message on LCD / ValVue (English)	Description	Device Action (Warning message only or Failsafe position)	Probable Cause	Recommended Action
RESET	Reset occurred due to command or power up. Always present after power up.	Warning message	Device reboot. The power recovered.	Standard Warning. Check power supply is operating correctly and is above 10 VDC.
SENSOR OUT	Sensor output was disconnected	Failsafe position: - Fail Low or High, user adjustable - <b>Fail Low only for a SIL device</b>	Sensor wiring disconnected or damaged	Check sensor wiring
SENSOR OUT OF NORMAL RANGE	Level sensor is outside its normal operating range (+/- 2.8 degree angle)	Warning message	Wrong calibration or sensor failure	Check calibration
SENSOR OUT OF RANGE	Level sensor was outside its operating range, defined after the sensor linearization process	Warning message	Wrong calibration or sensor failure	Check calibration
SENSOR ERROR	Compensated level sensor read was outside worst-case limits of sensor output	Failsafe position: - Fail Low or High, user adjustable - <b>Fail Low only for a SIL device</b>	Sensor and related components have failed	Replace the instrument
LOW LEVEL ALARM 1	Level was below the configured threshold for more than configured time	Warning message	Low level measure for more than the configured time	Check you complete level loop
LOW LEVEL ALARM 2	Level was below the configured threshold for more than configured time	Warning message	Low level measure for more than the configured time	Check you complete level loop
HIGH LEVEL ALARM 1	Level was above the configured threshold for more than configured time	Warning message	High level measure for more than the configured time	Check you complete level loop
HIGH LEVEL ALARM 2	Level was above the configured threshold for more than configured time	Warning message	High level measure for more than the configured time	Check you complete level loop
KEYBOARD FAILED	Pushbuttons or LCD do not operate properly	Warning message	The local pushbuttons and display is defective	Replace the pushbuttons and display assembly
FACTORY MODE	Factory mode faults	Warning message	The device was in factory mode	
TEMPERATURE MODULE OUT OF RANGE	Temperature of main circuit board exceeded normal operating temperature range	Warning message	Environment. Temperature of main circuit board was higher than +85 °C (+185 °F) or lower than -40 °C (-40 °F).	Take any action to ensure temperature does not exceed normal temperature range. Return the unit if it fails.
TEMPERATURE SENSOR OUT OF RANGE	Temperature of sensor circuit board exceeded normal operating temperature range	Warning message	Environment. Temperature of sensor circuit board was higher than +85 °C (+185 °F) or lower than -40 °C (-40 °F).	Take any action to ensure temperature does not exceed normal temperature range. Return the unit if it fails.
TEMPERATURE MODULE READ	Failure to read temperature sensor of main circuit board (module)	Failsafe position: - Fail Low or High, user adjustable - <b>Fail Low only for a SIL device</b>	Environment	Replace the instrument
TEMPERATURE SENSOR READ	Failure to read temperature sensor of sensor circuit board	Failsafe position: - Fail Low or High, user adjustable - <b>Fail Low only for a SIL device</b>	Environment	Replace the instrument

Message on LCD / ValVue (English)	Description	Device Action (Warning message only or Failsafe position)	Probable Cause	Recommended Action
TEMPERATURE SENSOR OF MAIN BOARD	Compensated temperature reading of sensor circuit board was outside the -55 °C (-67 °F) to +125 °C (+257 °F) for five reads in a row	Failsafe position: - Fail Low or High, user adjustable - <b>Fail Low only for a SIL device</b>	Environment. Ambient temperature exceeded operating temperature range.	Take any action to ensure temperature does not exceed normal temperature range. Return the unit if it fails.
TEMPERATURE SENSOR OF SENSOR BOARD	Compensated temperature reading of sensor circuit board was outside the -55 °C (-67 °F) to +125 °C (+257 °F) for five reads in a row	Failsafe position: - Fail Low or High, user adjustable - <b>Fail Low only for a SIL device</b>	Environment. Ambient temperature exceeded operating temperature range.	Take any action to ensure temperature does not exceed normal temperature range. Return the unit if it fails.
NVM CHECKSUM SENSOR READ	Non Volatile Memory checksum error of main circuit board	Failsafe position	Permanent corruption of the content in non-volatile memory occurred	Remove power to the device for two minutes and restart the device. If the failure persists, replace the device.
NVM MODULE WRITE	Non Volatile Memory checksum error of sensor circuit board	Failsafe position	Permanent corruption of the content in non-volatile memory occurred	Remove power to the device for two minutes and restart the device. If the failure persists, replace the device.
NVM SENSOR WRITE	Non Volatile Memory error of main circuit board module if write to FRAM failed or if data repairing in FRAM failed	Warning message	A problem occurred when attempting to write to the non-volatile memory	Clear the condition using ValVue software or HART host. If the failure persists, replace the device.
NVM MODULE TEST	Non Volatile Memory error of sensor circuit board if write to FRAM failed or if data repairing in FRAM failed	Warning message	A problem occurred when attempting to write to the non-volatile memory	Clear the condition using ValVue software or HART host. If the failure persists, replace the device.
NVM SENSOR TEST	Non Volatile Memory error of main circuit board module if both an FRAM record and its copy have CRC errors	Warning message	A problem occurred when testing the non-volatile memory	Clear the condition using ValVue software or HART host
RAM CHECKSUM ERROR	RAM checksum error	Warning message	A corruption of the content in non-volatile memory occurred	
FLASH CHECKSUM ERROR	Flash checksum error	Failsafe position	The firmware checksum was invalid due to data corruption	Remove power to the device for 2 minutes and restart the device. If the failure persists, replace the device.
RTOS SCHEDULING ERROR	A RTOS task overran itself	Warning message	The micro-controller failed an operation	
STACK ERROR	Stack error. A valid hidden record (in RAM) existing upon reset indicating that a stack overflow has occurred, as detected by the task switching code.	Warning message	A problem with the memory stack occurred	Clear the condition using ValVue software or HART host
FACTORY WRITE	Raw write to FRAM	Failsafe position	Raw write to FRAM. Technical fault to indicate a factory-only operation.	
WATCHDOG TIMEOUT	Device recovered after reset	Warning message	Device recovered after reset	Clear the condition using ValVue software or HART host
IRQ FAULT	Valid hidden record (in FRAM) existing upon reset that indicates that an illegal interrupt occurred	Warning message	An illegal circuit board interrupt occurred	Clear the condition using ValVue software or HART host. If the failure persists, replace the device.
TIMEOUT FLASH TEST	Time to complete the whole flashing process is over	Warning message	This message appears if a round of flash test is not completed in 2 hours	Clear the condition using ValVue software or HART host. If the failure persists, replace the device.

Message on LCD / ValVue (English)	Description	Device Action (Warning message only or Failsafe position)	Probable Cause	Recommended Action
MCU (Microprocessor Unit) Self-Check error	A fatal event (watchdog, illegal interrupt, stack overflow, data checksum) occurred	Failsafe position	A valid hidden record (in RAM) existing upon reset indicating that a fatal event (watchdog, illegal interrupt, stack overflow, data checksum) occurred twice in a 20-second period.	
<b>SOFTWARE ERROR</b>	Software error. The operating system failed in conducting a task.	Warning message	A valid hidden record (in RAM) existing upon reset indicating that a CPU exception (such as invalid instruction ) occurred OR invalid target mode of the device was found	Clear the condition using ValVue software or HART host. If the failure persists, replace the device.
<b>CALIBRATION ERROR</b>	Calibration of Analog Outputs (AOs) failed	Warning message	Calibration of AOs was outside the acceptable range when attempting to calibrate. Tank empty or wrong left/right mounting position.	Using precision measuring equipment, perform calibration according to boundary limits of AOs
<b>AUTOTUNE ERROR</b>	The Autotune procedure has been cancelled. Then the procedure failed to complete	Warning message	N/A	If required start again the Autotune procedure
<b>DISPLACER HEIGHT</b>	Error of displacer height information	Warning message	The span (in engineering units) exceeded the displacer height plus 8.2 mm, entered into the instrument data base	Check the engineering unit settings and the true displacer height
<b>MOUNTING</b>	Mounting error	Warning message	Mounting configuration (left/right) conflicted zero and span transmitter calibration	Check and do coupling if necessary. Recalibrate the device.
<b>TIME WORKING</b>	Working time exceeded the configurable threshold	Warning message	N/A	Perform maintenance of device
<b>CURRENT SIGNAL SENSOR</b>	Error of 4-20 mA sensor	Failsafe position: - Fail Low or High, user adjustable - <b>Fail Low only for a SIL device</b>	Readback sensor reading was outside the -1 to 30 mA range for five reads in a row	Clear the condition using ValVue software or HART host. If the failure persists, replace the device.
<b>LOOP OUTPUT WARNING</b>	Small mismatch between commanded and read 4-20 mA loop output (lower than 0.32 mA)	Warning message	Resistance change of external loop may have changed	Clear the condition using ValVue software or HART host. If the failure persists, replace the device.
<b>4-20 LOOP OUTPUT ERROR</b>	Mismatch between commanded and read 4-20 mA loop output (lower than 0.64mA)	Warning message	Resistance change of external loop may have changed	Clear the condition using ValVue software or HART host. If the failure persists, replace the device.
<b>LOCAL USER INTERFACE OFF</b>	User Interface (UI) was turned off	Warning message	When ambient temperature is lower than -15 °C (+5 °F), LCD display is frozen. Then UI are turned off to prevent from any error of setting	N/A
<b>VOLTAGE LOOP LOW</b>	Loop voltage below threshold	Warning message	Loop voltage or power supply voltage may have changed	Check the loop voltage and ensure it is above 10 VDC
<b>VOLTAGE LOOP HIGH</b>	Loop voltage above threshold	Warning message	Loop voltage or power supply voltage may have changed	Check the loop voltage and ensure it is below 40 VDC (or 30 VDC in intrinsically safe area)
<b>VOLTAGE SHUNT DIAGNOSTIC LOW</b>	Diagnostic (shunt) voltage below threshold	Warning message	Internal voltage may have changed	Clear the condition using ValVue software or HART host. If the failure persists, replace the device.
<b>VOLTAGE SHUNT DIAGNOSTIC HIGH</b>	Diagnostic (shunt) voltage above threshold	Warning message	Internal voltage may have changed	Clear the condition using ValVue software or HART host. If the failure persists, replace the device.

Message on LCD / ValVue (English)	Description	Device Action (Warning message only or Failsafe position)	Probable Cause	Recommended Action
VOLTAGE HART® LOW	HART voltage below threshold	Warning message	Internal voltage may have changed	Clear the condition using ValVue software or HART host. If the failure persists, replace the device.
VOLTAGE HART® HIGH	HART voltage above threshold	Warning message	Internal voltage may have changed	Clear the condition using ValVue software or HART host. If the failure persists, replace the device.
VOLTAGE CORE LOW	Core (CPU) voltage below threshold	Warning message	Internal voltage may have changed	Clear the condition using ValVue software or HART host. If the failure persists, replace the device.
VOLTAGE CORE HIGH	Core (CPU) voltage above threshold	Warning message	Internal voltage may have changed	Clear the condition using ValVue software or HART host. If the failure persists, replace the device.
LEVEL OUTPUT SATUTARED	Normal level output is clamped from below at 3.8 mA or from above at 20.5 mA	Warning message	Level variable is saturated and outside the normao operating range (3.8 to 20.5mA)	Reduce level measurement or checl configuration and calibration.
LEVEL RANGE	Specific Gravity recalculated range exceeded the linearization table limits	Warning message	Specific Gravity value(s) is(are) incorrect or bad calibration	Check Specific Gravity data or instrument calibration
LEVEL CLAMP	Internal position or adjusted position is outside the range of +/- 200%	Warning message	Bad calibration or mechanical hardware adjustment	Check displacer and torque tube S/A characteristics. Redo calibration.
SG LEVEL MAX	Absolute value of Specific Gravity recalculated range is too small	Warning message	Specific Gravity value(s) is(are) incorrect	Check Specific Gravity data
SENSOR SUPPLY VOLTAGE	Sensor supply voltage was outside sensor specification	Failsafe position	Lack of supply power or circuit board component failure	Clear the condition using ValVue software or HART host. Check supply power. If the failure persists, replace the device.
SENSOR OFF	Sensor turned off because of too low analog current during 5 seconds	Warning message	Lack of supply power or circuit board component failure	Clear the condition using ValVue software or HART host. Check supply power. If the failure persists, replace the device.
LEVEL FAILURE, OUT OF RANGE	Level value is critically out of range (above 105% or below -5%) for a predefined time (10 to 1000 seconds).	Failsafe position <b>- Fail Low only for a SIL device</b>	Bad calibration or mechanical hardware adjustment	Check displacer and torque tube S/A characteristics. Redo calibration.
SENSOR OUT OF RANGE (SIL)	Level value is critically out of normal range which includes limits of full linearization table range	<b>Failsafe position (Fail Low)</b>	Bad calibration or mechanical hardware adjustment	Check displacer and torque tube S/A characteristics. Redo calibration.
4-20 LOOP OUTPUT FAILURE (SIL)	Mismatch between commanded and read 4-20 mA loop output (lower than 0.64 mA)	<b>Failsafe position (Fail Low)</b>	Resistance change of external loop may have changed	Perform an instrument reset or switch off then switch on. If the failure persists, replace the device.

# APPENDICES

Menus of Transmitter models (12420 and 12430)

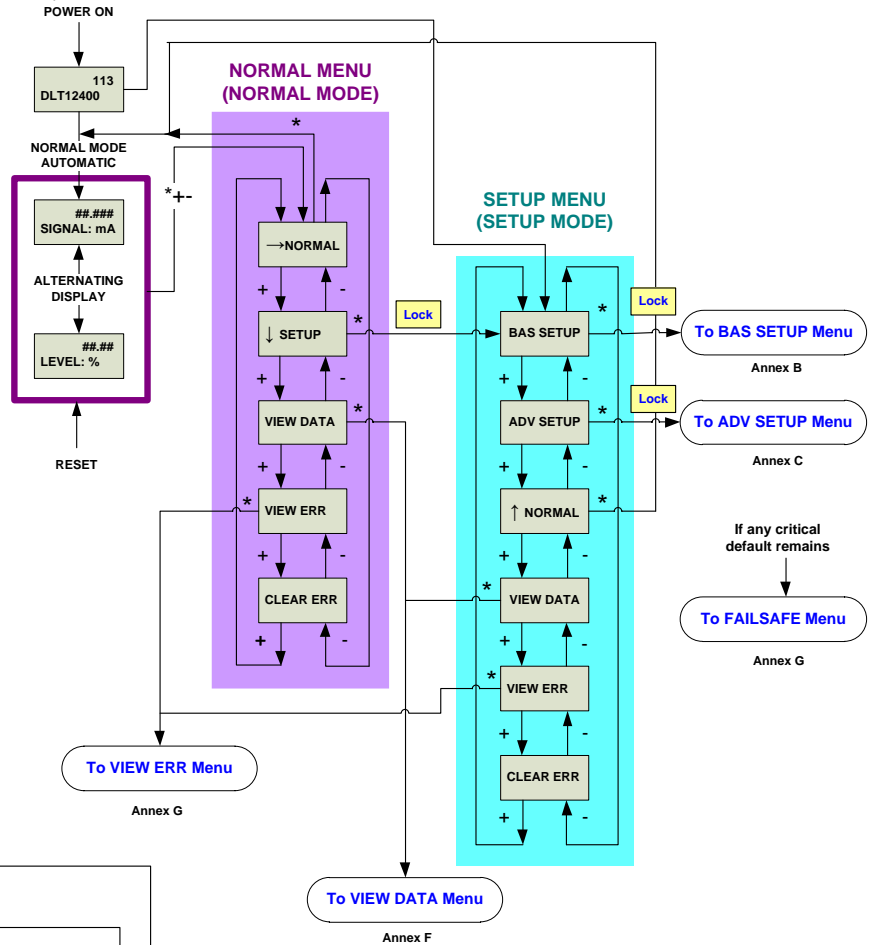

Menus of Controller model (12410)

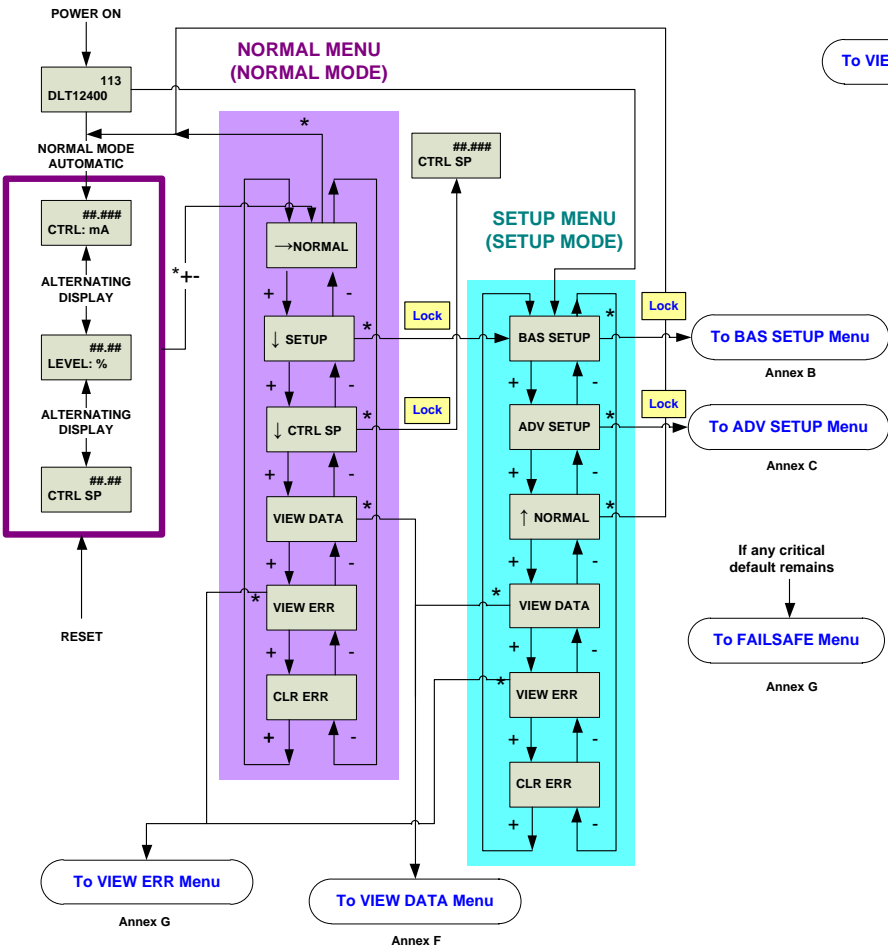

## APPENDIX A

### SCREEN DESCRIPTION FOR NORMAL MENU

→ <b>NORMAL</b>	In Normal Mode, the screen displays in sequence the value of the level and of the output current. Validate by pressing the * to stay in Normal mode.
↓ <b>SETUP</b>	Validate by pressing the * to enter the Setup Menu.
↓ <b>CONTROLLER SETPOINT</b>	Validate by pressing the * to set the setpoint of the control loop. This feature is displayed only if the instrument is a Level Controller (12410 model only).
<b>VIEW DATA</b>	Validate by pressing the * to enter the View Data Menu.
<b>VIEW ERRORS</b>	Validate by pressing the * to read eventual error indication(s) since last clear of errors.
<b>CLEAR ERRORS</b>	Validate by pressing the * to clear error message(s) saved in memory.

### SCREEN DESCRIPTION FOR SETUP MENU

<b>BASIC SETUP</b>	Validate by pressing the * to enter the Basic Setup Menu.
<b>ADVANCED SETUP</b>	Validate by pressing the * to enter the Advanced Setup Menu.
<b>NORMAL</b>	Validate by pressing the * to return to Normal Menu. In Normal Mode, the screen displays in sequence the value of the level and of the output current.
<b>VIEW DATA</b>	Validate by pressing the * to enter the View Data Menu.
<b>VIEW ERRORS</b>	Validate by pressing the * to read eventual error indication(s) since last clear of errors.
<b>CLEAR ERRORS</b>	Validate by pressing the * to clear error message(s) saved in memory.

#### Note on pushbuttons lock:

Access to main functions can be locked using the hardware lock jumper, located in the front view of the instrument head, behind the main cover, or by software activation (with ValVue software or a HART handled terminal).

When set to the secure position, shorting the two-pin header, no change of setting parameter is allowed (no access to Setup and Clear Errors menus). It is not allowed to write any new data into the instrument memory. Pushbuttons, ValVue and any HART® handheld are locked out, except to read data (normal, view data and view errors menus). In such case, LOCK message is indicated on LCD display when user presses a button.

**This hardware lock jumper must be set in the secure (locked) position to be used as a SIL 2 instrument.**



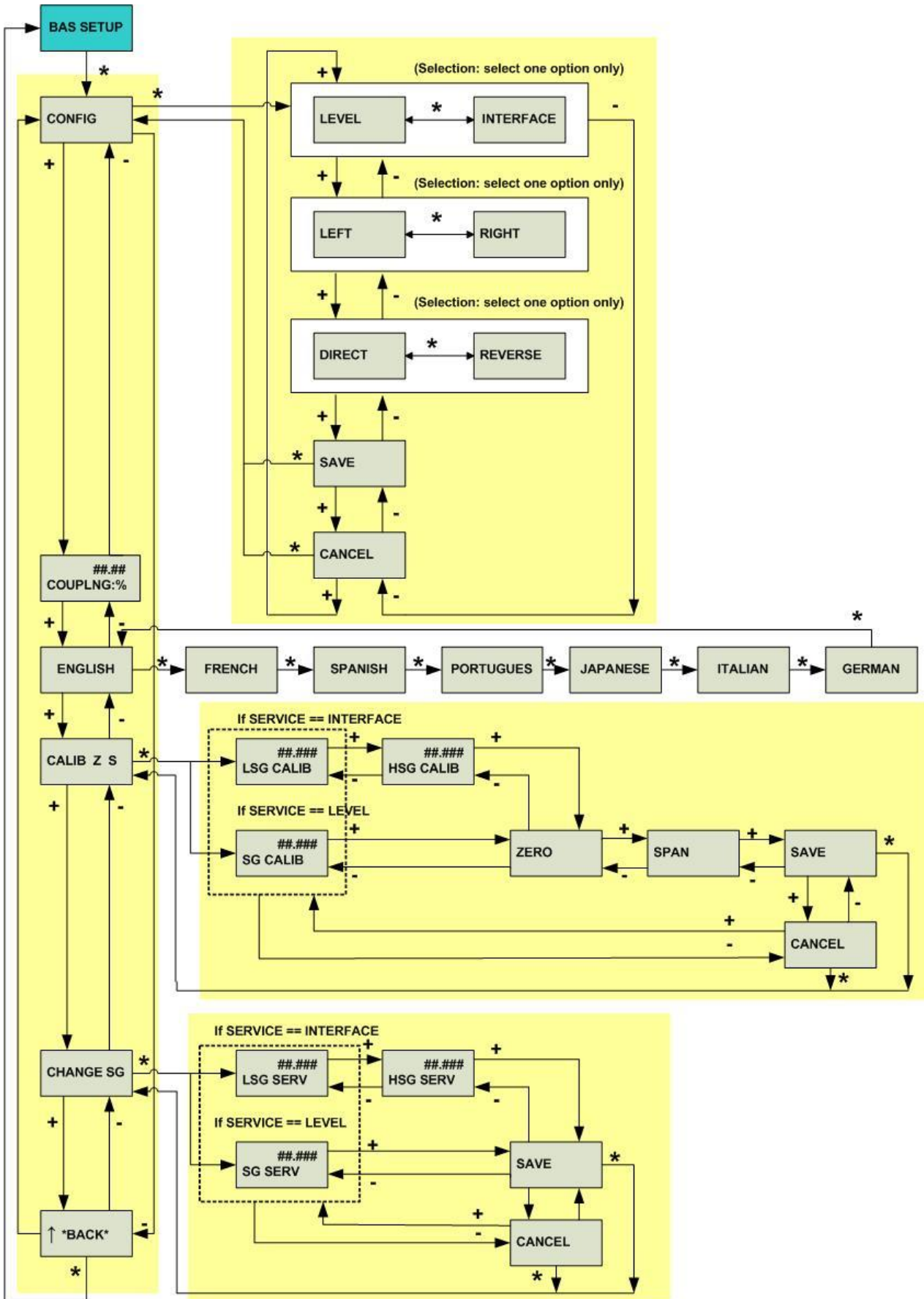

## APPENDIX B

### SCREEN DESCRIPTION FOR BASIC SETUP MENU – 1/2

<b>BASIC SETUP</b>	Validate by pressing the * to enter the Basic Setup Menu.
<b>CONFIGURATION</b>	Validate by pressing the * to enter the Configuration sub-menu.
<b>LEVEL</b>	The instrument measures the level of a liquid in which the displacer is partially immersed.
<b>INTERFACE</b>	The instrument is used to measure the interface level between 2 non-miscible liquids of different specific gravities. The displacer always must be immersed.
<b>LEFT</b>	Select the item in accordance with the relative mounting position of the instrument housing versus the displacer. The standard mounting position is LEFT.
<b>RIGHT</b>	Optionally, the mounting position may be RIGHT.
<b>DIRECT</b>	An increase in level induces an increase of the loop current. Standard action is DIRECT.
<b>REVERSE</b>	Optionally, a REVERSE action can be selected. The loop current decreases when the level increases.
<b>SAVE</b>	Validate by pressing the * to start the saving procedure of parameters previously entered in the instrument memory.
<b>CANCEL</b>	Validate by pressing the * to cancel the parameters saving procedure.
<b>COUPLING : %</b>	Only necessary on instrument head delivered alone without torque tube. Function used to mechanically couple the sensor to the torque tube rod. Requires simulating a displacer half immersed in a liquid of S.G. 1.4. The value read must be between -5% and + 5%. See Section 7.1.
<b>ENGLISH FRENCH SPANISH PORTUGUESE JAPANESE ITALIAN GERMAN</b>	Indicates the language in which the data are displayed on the screen.
<b>CALIBRATION of ZERO and SPAN</b>	Validate by pressing the * to get to sub-menu for Specific Gravity of Calibration setting, and Zero and Span calibration.
<b>SPECIFIC GRAVITY of CALIBRATION</b>	Validate by pressing the * to set the specific gravity of the liquid used during the calibration procedure. Settable value ranges from 0.001 to 10.
<b>LOW SPECIFIC GRAVITY of CALIBRATION</b>	Used in case of an Interface instrument. Validate by pressing the * to set the Specific Gravity of the lighter liquid used for calibration. Settable values range from 0.001 to the value of HSG CAL.
<b>HIGH SPECIFIC GRAVITY of CALIBRATION</b>	Used in case of an Interface instrument. Validate by pressing the * to set the Specific Gravity of the heavier liquid used for calibration. Settable values range from the value of LSG CAL to 10.0.

## APPENDIX B

### SCREEN DESCRIPTION FOR BASIC SETUP MENU – 2/2

<b>ZERO</b>	When displayed, empty the tank (or simulate) so that displacer is fully out of liquid. Wait until the displacer is stable then press * to define the low reference (REF L).
<b>SPAN</b>	When displayed, fill the tank (or simulate) so that displacer is fully immersed in liquid. Wait until the displacer is stable then press * to define the high reference (REF H).
<b>SAVE</b>	Validate by pressing the * to start the saving procedure of parameters previously entered in the instrument memory.
<b>CANCEL</b>	Validate by pressing the * to cancel the parameters saving procedure.
<b>CHANGE SPECIFIC GRAVITY</b>	Enter that function to set the Specific Gravity of Service in case it is different from the Specific Gravity of Calibration.
<b>SPECIFIC GRAVITY of SERVICE</b>	Validate by pressing the * to set the Specific Gravity of the liquid of service if it is different from the Specific Gravity of Calibration. Settable value ranges from 0.001 to 10.
<b>LOW SPECIFIC GRAVITY of SERVICE</b>	Used in case of an interface instrument. Validate by pressing the * to set the Specific Gravity of the lighter liquid used in service if it is different from LSG CAL. Settable values range from 0.001 to the value of HSG SER.
<b>HIGH SPECIFIC GRAVITY of SERVICE</b>	Used in case of an interface instrument. Validate by pressing the * to set the Specific Gravity of the heavier liquid in service if it is different from HSG CAL. Settable values range from LSG SER to 10.0.
<b>SAVE</b>	Validate by pressing the * to start the saving procedure of configuration parameters previously entered in the instrument memory.
<b>CANCEL</b>	Validate by pressing the * to cancel the parameters saving procedure.
<b>↑ BACK</b>	Return to previous menu.

# APPENDIX C

(see following pages)

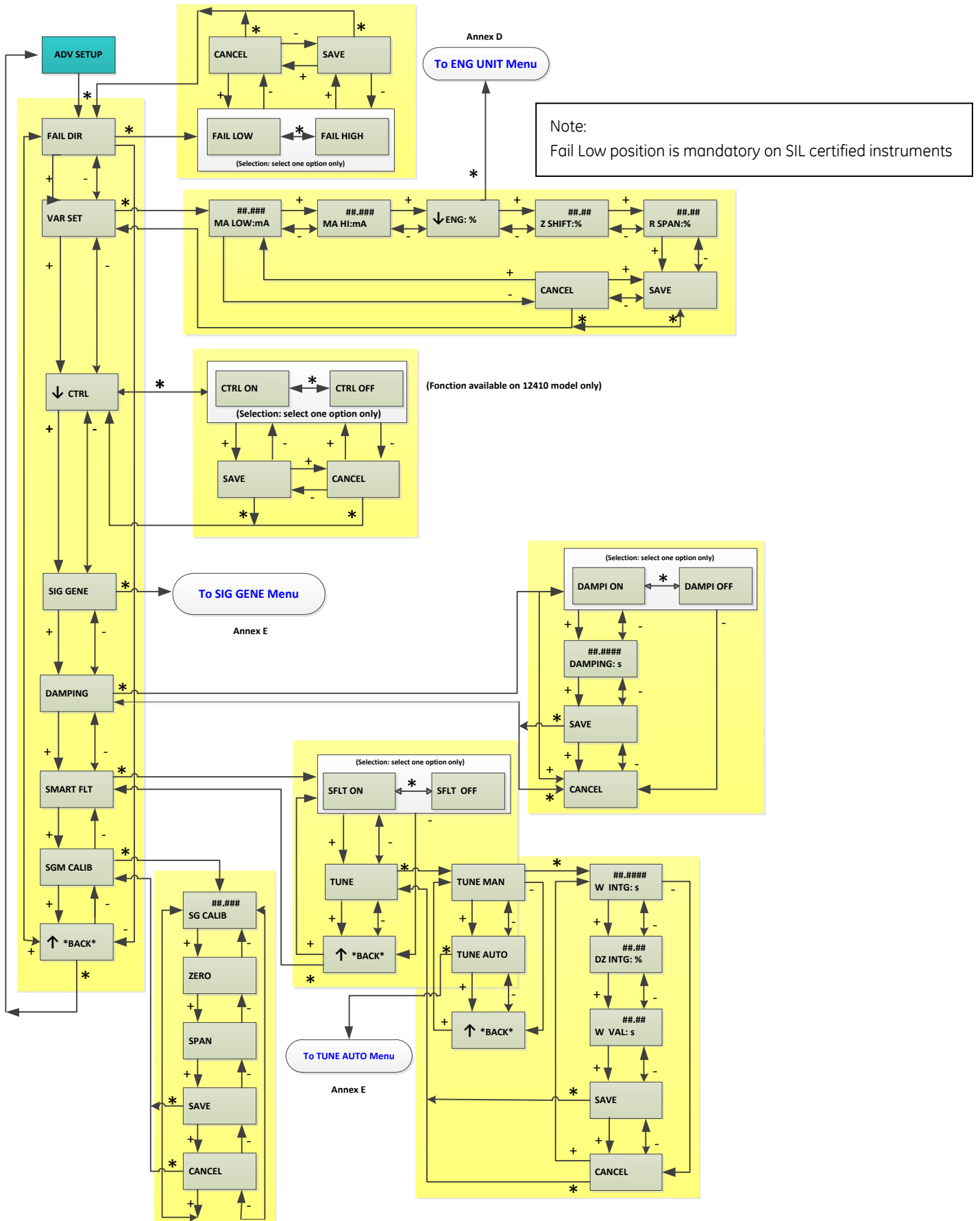

## APPENDIX C

### SCREEN DESCRIPTION FOR ADVANCED SETUP MENU – 1/2

<b>ADVANCED SETUP</b>	Validate by pressing the * to enter the Advanced Setup menu.
<b>FAILSAFE POSITION DIRECTION</b>	Validate by pressing the * to define the failsafe position direction in case of activation of Failsafe mode (severe faults).
<b>FAILSAFE POSITION LOW</b>	Define the failsafe position in case of severe faults. The instrument will generate a current safety signal below 3.6 mA. <b><u>Fail Low position in mandatory for SIL certified instruments</u></b>
<b>FAILSAFE POSITION HIGH</b>	Define the failsafe position in case of severe faults. The instrument will generate a current safety signal above 21 mA. Fail High position is not available for SIL certified instruments (Fail Low mandatory)
<b>SAVE</b>	Validate by pressing the * to start the saving procedure of parameters previously entered in the instrument memory.
<b>CANCEL</b>	Validate by pressing the * to cancel the parameters saving procedure.
<b>VARIABLE SETUP</b>	Validate by pressing the * to enter the sub-menu to set the additional variables.
<b>MA LOW</b>	Validate by pressing the * to adjust the current equivalent to the Low Level position (REF L). The value, generally 4 mA, must be between 3.8 mA and the high current signal value (MA HIGH).
<b>MA HIGH</b>	Validate by pressing the * to adjust the current equivalent to the High Level position (REF H). The value, generally 20 mA, must be between the low current signal value (MA LOW) and 20.5 mA.
<b>ENGINEERING UNIT:%</b>	Validate by pressing the * to enter the sub-menu to define the level variable and select the desired engineering unit (usually %).
<b>ZERO SHIFT:%</b>	Validate by pressing the * to set the zero of a reduced range. In case of an interface instrument, when the Specific Gravities of Service [LSG SER] and [HSG SER] are different from those of Calibration [LSG CAL] and [HSG CAL], zero shift is automatically set to the value resulting from formula : $\frac{([LSG SER] - [LSG CAL])}{([HSG SER] - [LSG SER])}$ Value ranges from -9999.9% to +9999.9%.
<b>REDUCED SPAN: %</b>	Validate by pressing the * to set the span of a reduced range. Value ranges from 0.0% to 99%.
<b>↓ CONTROLLER</b>	Validate by pressing the * to enter the Controller sub-menu and define if the Controller function is activated or not. <b>Note: only the Transmitter function is SIL certified.</b>
<b>CONTROLLER ON</b>	The Controller function is activated
<b>CONTROLLER OFF</b>	The Controller function is not activated
<b>SIGNAL GENERATOR</b>	Validate by pressing the * to enter the sub-menu allowing to generate a loop current to a defined value independently of true level measurement.
<b>DAMPING</b>	Validate by pressing the * to enter the Damping menu. This is a first order filtering function which operates on the output current signal.
<b>DAMPING ON</b>	Activate first order Filtering function.
<b>DAMPING OFF</b>	Deactivate first order Filtering function.
<b>DAMPING:s</b>	Validate by pressing the * to set the damping parameter which is a T63 time: time taken for a 63% response to a level step change. Damping time can be set between 0.1 s and 32 s.

## APPENDIX C

### SCREEN DESCRIPTION FOR ADVANCED SETUP MENU – 2/2

<b>SMART FILTERING</b>	Validate by pressing the * to enter the Smart Filtering menu.
<b>SMART FILTERING ON</b>	Activate the Smart Filtering function.
<b>SMART FILTERING OFF</b>	Deactivate the Smart Filtering function.
<b>TUNE</b>	Validate by pressing the * to manually or automatically tune the smart filtering parameters.
<b>DEAD ZONE of INTEGRATION : %</b>	Manual adjustment of this parameter between 0.01% and 10%.
<b>WINDOW of VALIDATION: s</b>	Manual adjustment of this parameter between 0.1 s and 32 s.
<b>AUTOMATIC TUNE</b>	Validate by pressing the * to automatically tune the smart filtering parameters.
<b>↑ BACK</b>	Return to previous menu.
<b>SPECIFIC GRAVITY METER CALIBRATION</b>	Validate by pressing the * to calibrate the Specific Gravity Meter. Enter the sub-menu and proceed as a normal level calibration.
<b>SPECIFIC GRAVITY for CALIBRATION</b>	Validate by pressing the * to set the specific gravity of the liquid used during the calibration procedure. Settable value ranges from 0.001 to 10.
<b>ZERO</b>	When displayed, empty the tank (or simulate) so that displacer is fully out of liquid. Wait till the displacer is stable then press * to define the zero, which is the Reference Low (REF L).
<b>SPAN</b>	When displayed, fill the tank (or simulate) so that displacer is fully immersed in liquid. Wait till the displacer is stable then press * to define the span, which is the Reference High (REF H).
<b>CANCEL</b>	Validate by pressing the * to cancel the parameters saving procedure.
<b>SAVE</b>	Validate by pressing the * to start the saving procedure of parameters previously entered in the instrument memory.

# APPENDIX D

(see following pages)



APPENDIX D

ENG UNIT Menu

(assume % is current UNIT we select)

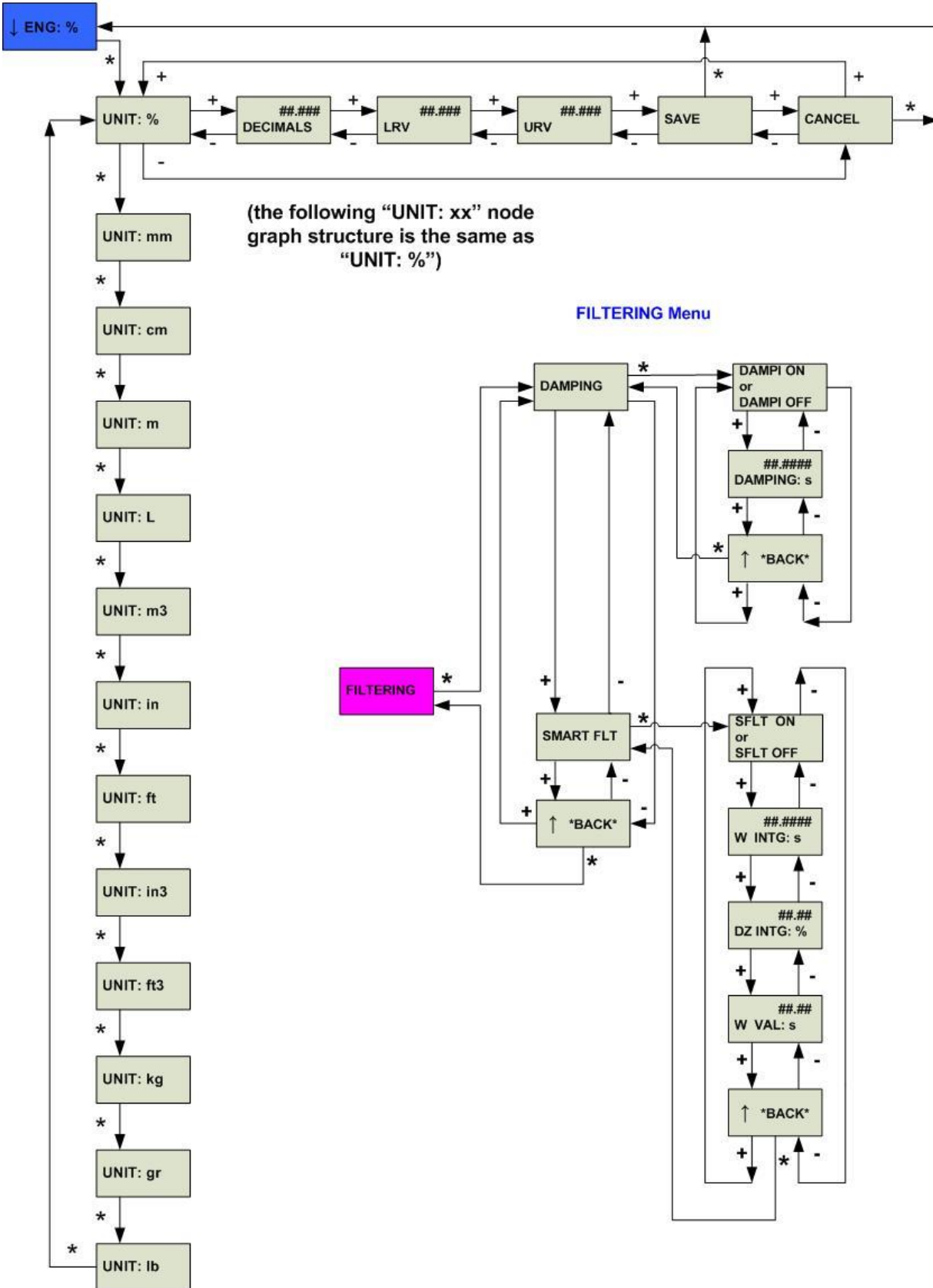

## APPENDIX D

### SCREEN DESCRIPTION FOR ENGINEERING UNIT MENU

↓ <b>ENG:%</b>	Validate by pressing the * to enter the sub-menu related to the level variable setting in engineering units.
<b>UNIT:%</b>	Validate by pressing the * to select the desired engineering unit (% , cm, m, inch...) used to express the level variable. Generally, the engineering unit is in %.
<b>##.### DECIMALS</b>	Validate by pressing the * to set the number of decimals after the dot.
<b>LOWER REFERENCE VALUE</b>	Validate by pressing the * to set the lower level value expressed in industrial unit corresponding to the Low Reference (REF L). Always set at 0 if unit is %. Value ranges from 0 to value of UPPER REFERENCE VALUE.
<b>UPPER REFERENCE VALUE</b>	Validate by pressing the * to set the higher level value expressed in industrial unit corresponding to the High Reference (REF H). Always set at 100 if unit is %. Value ranges from LOWER REFERENCE VALUE to 9999.9.
<b>SAVE</b>	Validate by pressing the * to start the saving procedure of parameters previously entered in the instrument memory.
↑ <b>BACK</b>	Return to previous menu.

### SCREEN DESCRIPTION FOR FILTERING MENU

<b>FILTERING</b>	Validate by pressing the * to check the Filtering data.
<b>DAMPING</b>	Validate by pressing the * to check the Damping data.
<b>DAMPING ON</b>	Indicates first order Filtering function is activated.
<b>DAMPING OFF</b>	Indicates first order Filtering function is not activated.
<b>DAMPING:s</b>	Indicates damping value adjusted in the Advanced Setup menu.
↑ <b>BACK</b>	Return to previous menu.
<b>SMART FILTERING</b>	Validate by pressing the * to check the Smart Filtering parameters.
<b>SMART FILTERING ON</b>	Indicates the Smart Filtering function is activated.
<b>SMART FILTERING OFF</b>	Indicates the Smart Filtering function is not activated.
<b>WINDOW of INTEGRATION : s</b>	Indicates the Window of Integration value adjusted in the Advanced Setup menu.
<b>DEAD ZONE of INTEGRATION : %</b>	Indicates the Dead Zone of Integration value adjusted in the Advanced Setup menu.
<b>WINDOW of VALIDATION</b>	Indicates the Window of Validation value adjusted in the Advanced Setup menu.
↑ <b>BACK</b>	Return to previous menu.

4-20mA GENERATION Menu

12420 Model

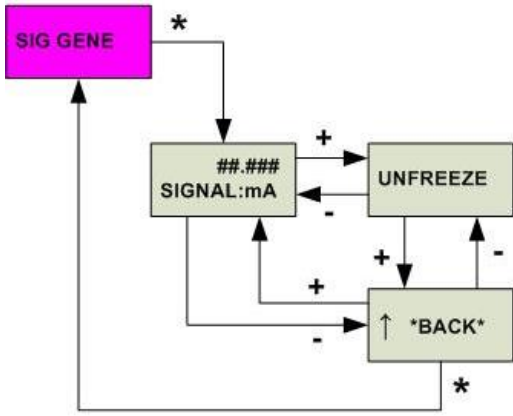

12410 or 12430 Models

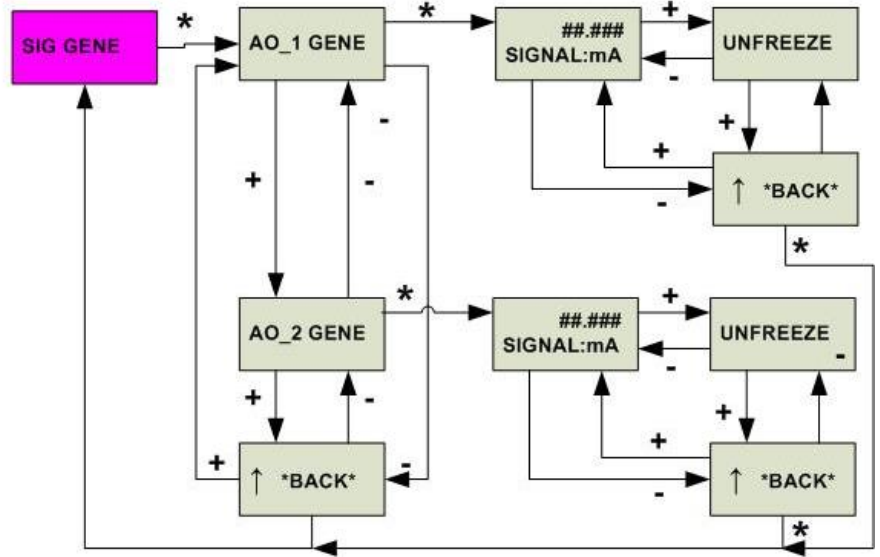

AUTOMATIC TUNING Menu

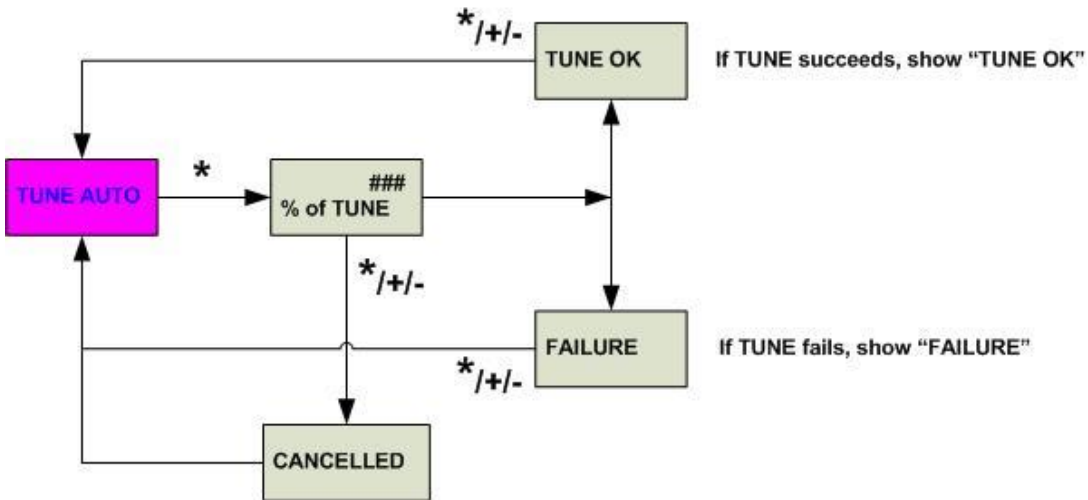

## APPENDIX E

### SCREEN DESCRIPTION FOR 4-20mA GENERATION MENU

<b>SIGNAL GENERATOR</b>	Validate by pressing the * to enter the sub-menu allowing to generate a loop current to a defined value independently of true level measurement.
<b>SIGNAL:mA</b>	Validate by pressing the * to set the loop current to a value between 3.6 and 23 mA.
<b>SAVE</b>	Validate by pressing the * to save the data.
<b>↑ BACK</b>	Return to previous menu.

<b>SIGNAL GENERATOR</b>	Validate by pressing the * to enter the sub-menu allowing to generate a loop current to a defined value independently of true level measurement.
<b>AO_1 GENERATOR</b>	Validate by pressing the * to enter the sub-menu allowing to set the Analog Output #1 loop current to a defined value.
<b>SIGNAL:mA</b>	Validate by pressing the * to set the AO_1 loop current to a value between 3.6 and 23 mA.
<b>SAVE</b>	Validate by pressing the * to save the data.
<b>↑ BACK</b>	Return to previous menu.
<b>AO_2 GENERATOR</b>	Validate by pressing the * to enter the sub-menu allowing to set the Analog Output #2 loop current to a defined value.

### SCREEN DESCRIPTION FOR AUTOMATIC TUNING MENU

<b>TUNE AUTOMATIC</b>	Validate by pressing the * to automatically tune the smart filtering parameters.
<b>% of TUNE</b>	Display the % of Auto Tune procedure execution.
<b>TUNE OK</b>	Auto Tune procedure of Smart Filtering parameters has been successfully completed.
<b>FAILURE</b>	Auto Tune procedure of Smart Filtering parameters has failed.
<b>CANCELLED</b>	Cancel the on-going procedure.

VIEW DATA Menu

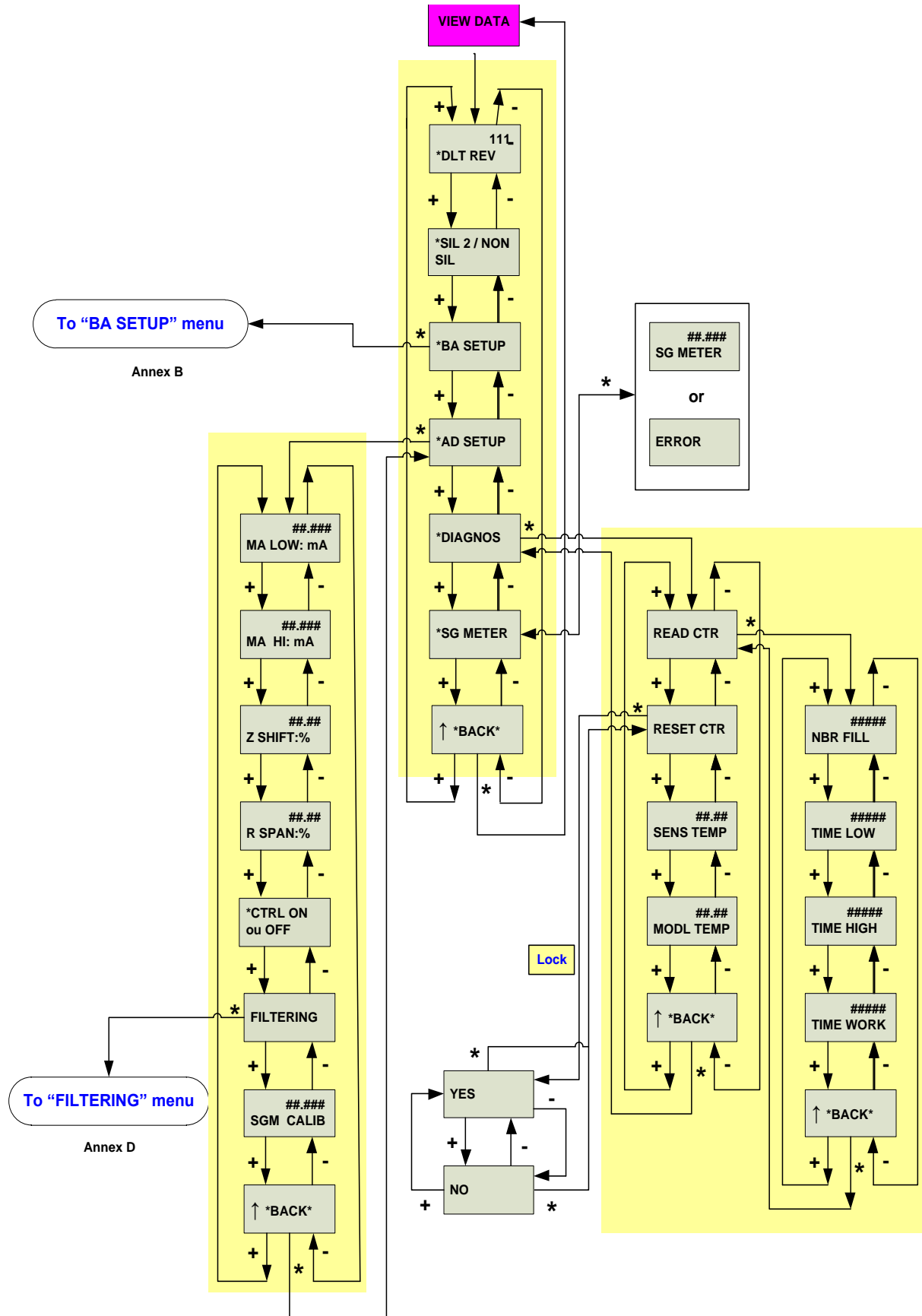

## APPENDIX F

### SCREEN DESCRIPTION FOR VIEW DATA MENU

<b>* DLT REVISION</b>	Indicates current instrument revision (firmware and hardware).
<b>* SIL 2 / NON SIL</b>	Indicates if the device is configured as a SIL 2 certified instrument or not.
<b>* BASIC SETUP</b>	Validate by pressing the * to read current Basic Setup data.
<b>* ADVANCED SETUP</b>	Validate by pressing the * to read current Advanced Setup data.
<b>* DIAGNOSTIC</b>	Validate by pressing the * to enter the Diagnostic menu.
<b>READ COUNTER</b>	Validate by pressing the * to enter the sub-menu of cumulated Diagnostic data.
<b>NUMBER of FILLINGS</b>	Totalizes the amount of liquid entering the tank. Counter increments by one when accumulated positive change in level corresponds to one height of displacer.
<b>TIME LOW</b>	Time (number of hours) during which the instrument worked within +/-5 % of low level calibrated value.
<b>TIME HIGH</b>	Time (number of hours) during which the instrument worked within +/-5 % of high level that is between 95 % and 105 % of calibrated value.
<b>TIME WORKING</b>	Time (number of hours) during which the instrument has been on service.
<b>↑ BACK</b>	Return to previous menu.
<b>RESET COUNTER</b>	Validate by pressing the * to reset the diagnostic data to zero in memory.
<b>SENSOR TEMPERATURE</b>	Indicates sensor circuit board temperature.
<b>MODULE TEMPERATURE</b>	Indicates main circuit board temperature.
<b>↑ BACK</b>	Return to previous menu.
<b>* SPECIFIC GRAVITY METER</b>	Validate by pressing the * to read the Specific Gravity value of the liquid when the displacer is fully immersed. The Specific Gravity Meter must have been previously calibrated. If the Specific Gravity Meter has not been calibrated, the screen ERROR is displayed: this is the only way to know if the Specific Gravity Meter has been previously calibrated. In both cases, push * to return to main Diagnostic menu.
<b>ERROR</b>	Displayed when the Specific Gravity Meter has not been calibrated.
<b>↑ BACK</b>	Return to previous menu.

APPENDIX G

FAILSAFE Menu

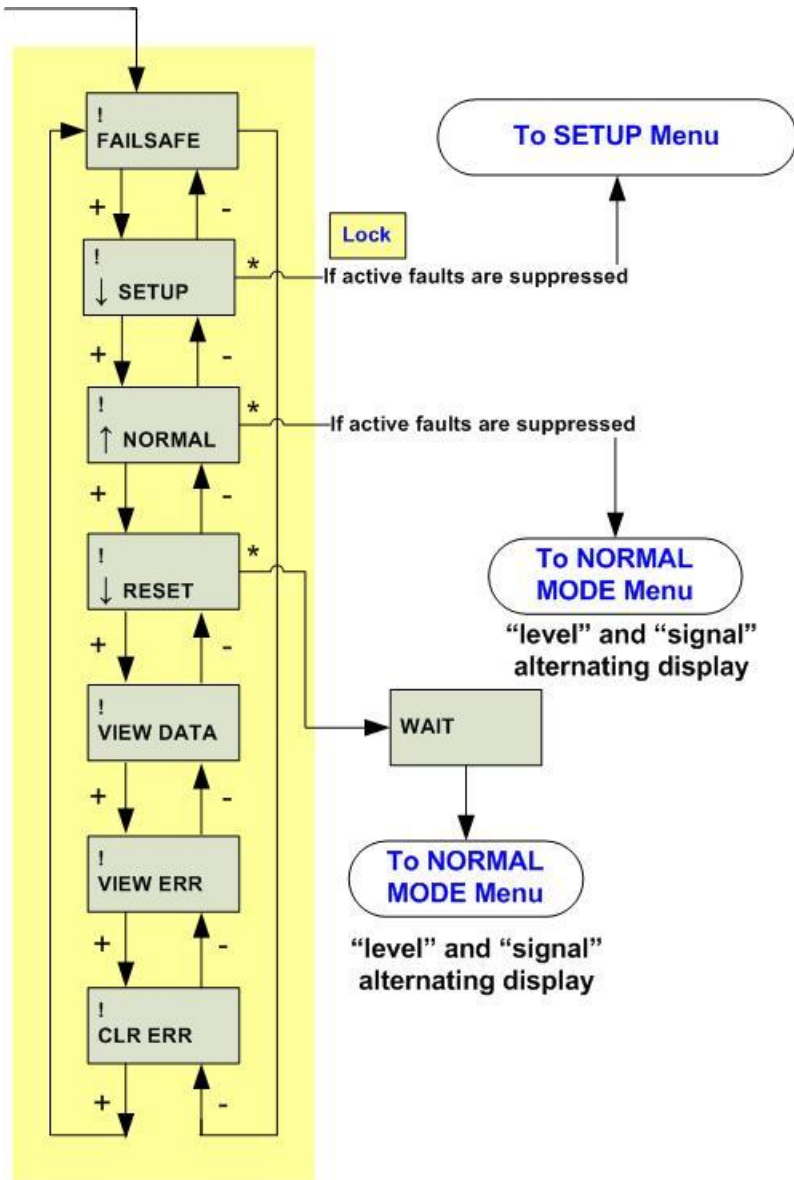

VIEW ERROR Menu

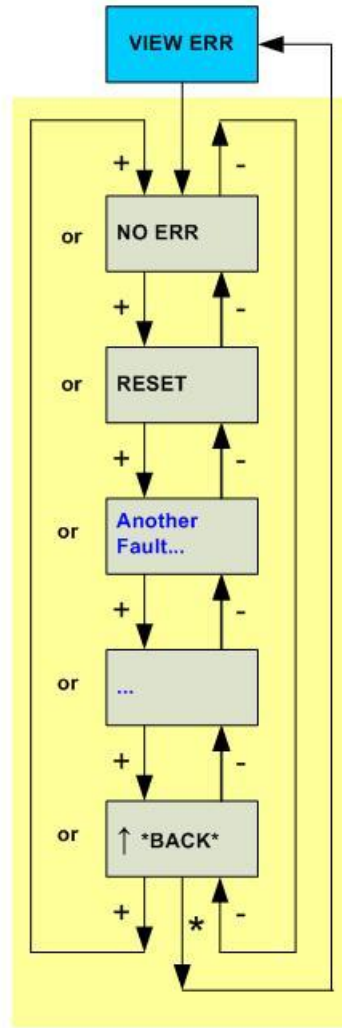

Please consult Section 10.7 to get the full list of errors or faults.

## APPENDIX G

### SCREEN DESCRIPTION FOR FAILSAFE MENU

<b>FAILSAFE</b>	Indicates that instrument is in Failsafe mode. If FAIL LOW was configured, the instrument will generate a current safety signal below 3.6 mA. If FAIL HIGH was configured, the instrument will generate a current safety signal above 23 mA.
↓ <b>SETUP</b>	Validate by pressing the * to enter the Setup Menu.
↑ <b>NORMAL</b>	Validate by pressing the * to return to Normal Menu. In Normal mode, the screen alternatively displays the level value and the loop current.
↓ <b>RESET</b>	Validate by pressing the * to put the instrument in factory set configuration.
<b>VIEW DATA</b>	Validate by pressing the * to enter the View Data Menu.
<b>VIEW ERROR</b>	Validate by pressing the * to read eventual error indication(s) since last clear of errors.
<b>CLEAR ERROR</b>	Validate by pressing the * to clear error message(s) saved in memory.

### SCREEN DESCRIPTION FOR VIEW ERROR MENU

<b>NO ERROR</b>	Indicates there is no error in memory.
<b>RESET</b>	Validate by pressing the * to put the instrument in factory set configuration.
Another Fault...	Indicates eventual other error.
...	
↑ <b>BACK</b>	Return to previous menu.

#### Note on pushbuttons lock:

Access to main functions can be locked upon the position of the hardware lock jumper located in the front view of the instrument head, behind the main cover, or by software activation (with ValVue software or a HART handled terminal).

When set to the secure position, shorting the two-pin header, no change of setting parameter is allowed (no access to Setup and Clear Errors menus). It is not allowed to write any new data into the instrument memory. Pushbuttons, ValVue and any HART® handheld are locked out, except to read data (normal, view data and view errors menus). In such case, LOCK message is indicated on LCD display when user presses a button.

**This hardware lock jumper must be set in the secure (locked) position to be used as a SIL 2 instrument.**



# DIRECT SALES OFFICE LOCATIONS

AUSTRALIA  
Brisbane  
Phone: +61-7-3001-4319  
Fax: +61-7-3001-4399

Perth  
Phone: +61-8-6595-7018  
Fax: +61-8-6595-7299

Melbourne  
Phone: +61-3-8807-6002  
Fax: +61-3-8807-6577

BELGIUM  
Phone: +32-2-344-0970  
Fax: +32-2-344-1123

BRAZIL  
Phone: +55-19-2104-6900

CHINA  
Phone: +86-10-5738-8888  
Fax: +86-10-5918-9707

FRANCE  
Courbevoie  
Phone: +33-1-4904-9000  
Fax: +33-1-4904-9010

GERMANY  
Ratingen  
Phone: +49-2102-108-0  
Fax: +49-2102-108-111

INDIA  
Mumbai  
Phone: +91-22-8354790  
Fax: +91-22-8354791

New Delhi  
Phone: +91-11-2-6164175  
Fax: +91-11-5-1659635

ITALY  
Phone: +39-081-7892-111  
Fax: +39-081-7892-208

JAPAN  
Tokyo  
Phone: +81-03-6871-9008  
Fax: +81-03-6890-4620

KOREA  
Phone: +82-2-2274-0748  
Fax: +82-2-2274-0794

MALAYSIA  
Phone: +60-3-2161-03228  
Fax: +60-3-2163-6312

MEXICO  
Phone: +52-55-3640-5060

THE NETHERLANDS  
Phone: +31-15-3808666

RUSSIA  
Veliky Novgorod  
Phone: +7-8162-55-7898  
Fax: +7-8162-55-7921

Moscow  
Phone: +7 495-585-1276  
Fax: +7 495-585-1279

SAUDI ARABIA  
Phone: +966-3-341-0278  
Fax: +966-3-341-7624

SINGAPORE  
Phone: +65-6861-6100  
Fax: +65-6861-7172

SOUTH AFRICA  
Phone: +27-11-452-1550  
Fax: +27-11-452-6542

SOUTH & CENTRAL  
AMERICA AND THE CARIBBEAN  
Phone: +55-12-2134-1201  
Fax: +55-12-2134-1238

SPAIN  
Phone: +34-93-652-6430  
Fax: +34-93-652-6444

UNITED ARAB EMIRATES  
Phone: +971-4-8991-777  
Fax: +971-4-8991-778

UNITED KINGDOM  
Bracknell  
Phone: +44-1344-460-500  
Fax: +44-1344-460-537

UNITED STATES  
Jacksonville, Florida  
Phone: +1-904-570-3409  
Fax: +1-508-427-8971

Deer Park, Texas  
Phone: +1-281-884-1000  
Fax: +1-281-884-1010

Houston, Texas  
Phone: +1-281-671-1640  
Fax: +1-281-671-1735

[bhge.com](http://bhge.com)

\*Denotes a registered trademark of the Baker Hughes, a GE company.

Other company names and product names used in this document are the registered trademarks or trademarks of their respective owners.

© 2017 Baker Hughes, a GE company. All rights reserved.

Baker Hughes, a GE company, LLC and its affiliates ("BHGE") provides this information on an "as is" basis for general information purposes and believes it to be accurate as of the date of publication. BHGE does not make any representation as to the accuracy or completeness of the information and makes no warranties of any kind, specific, implied or oral, to the fullest extent permissible by law, including those of merchantability and fitness for a particular purpose or use. BHGE hereby disclaims any and all liability for any direct, indirect, consequential or special damages, claims for lost profits, or third party claims arising from the use of the information, whether a claim is asserted in contract, tort, or otherwise. Baker Hughes, a GE company and the GE monogram are trademarks of the General Electric Company.

