

Masoneilan* Valves

87/88 Pneumatic Multi-Spring Diaphragm Actuators

Actuator air action can be changed in the field for increased flexibility and reduced inventory.



imagination at work

Numbering System

1st	2nd
8	

Actuator Type
87 Air to Close
88 Air to Open

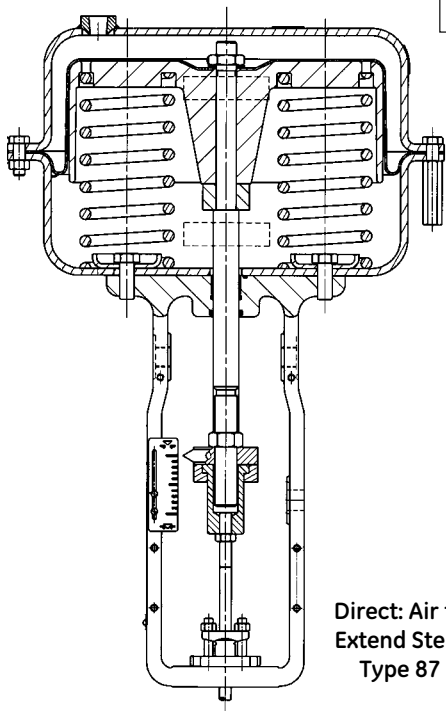

Direct: Air to Extend Stem
Type 87

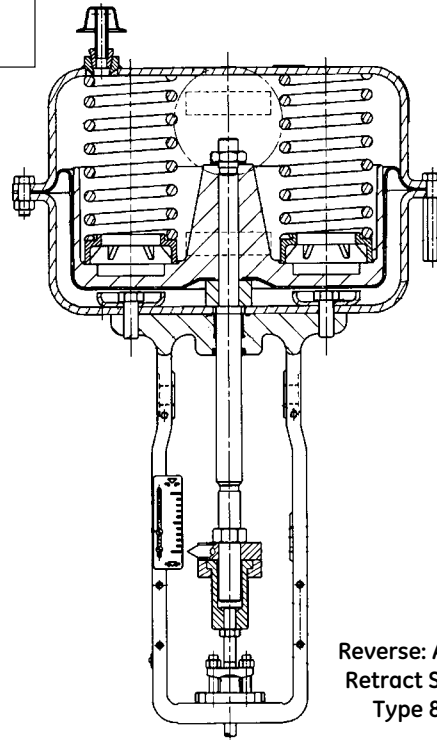

Reverse: Air to Retract Stem
Type 88

Handwheel

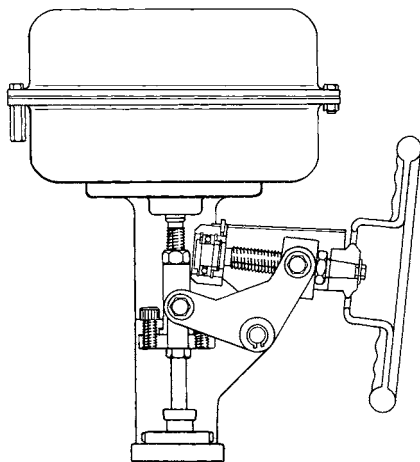

Actuator Size	Maximum Travel		Equivalent Air Supply		Number of Turns
	Inches	(mm)	psi	(bar)	
6	0.8	20	60	4.1	5
10	1.5	38	60	4.1	9
16	2.5	63	60	4.1	17
23	2.5	63	60	4.1	25

Specifications

Bench ranges available: 3-15, 6-30, 11-23, 21-45 for all actuator sizes

Actuator Size	Diaphragm Effective Area		Stem Travel		Max Supply	
	sq. in.	sq. cm.	(inches)	mm	(psi)	(bar)
6	60	387	0.8	20	60	4.1
10	100	645	0.8 / 1.5	20 / 38	60	4.1
16	160	1032	0.8 / 1.5 / 2.0 / 2.5	20 / 38 / 50 / 63	60	4.1
23	230	1484	0.8 / 1.5 / 2.0 / 2.5	20 / 38 / 50 / 63	60	4.1

Standard Springs

Actuator Size 6, 10, 16, and 23

Spring Type	Spring Qty	Placement
3-15	3	Lower Level
6-30	6	Lower Level
11-23	3	Upper Level
21-45	6	Upper Level

Air Connections

Standard: 1/4" NPT - Size 6, 10 1/2" NPT - Size 16, 23

Optional: 1/2" NPT - Size 6, 10

Materials

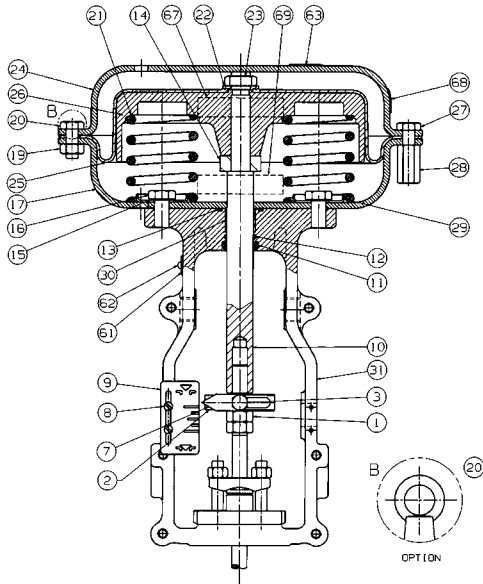

Size 6 Actuator

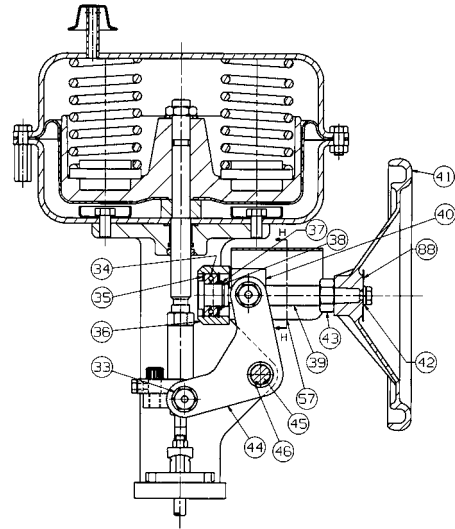

Size 10 Actuator
with Optional Handwheel

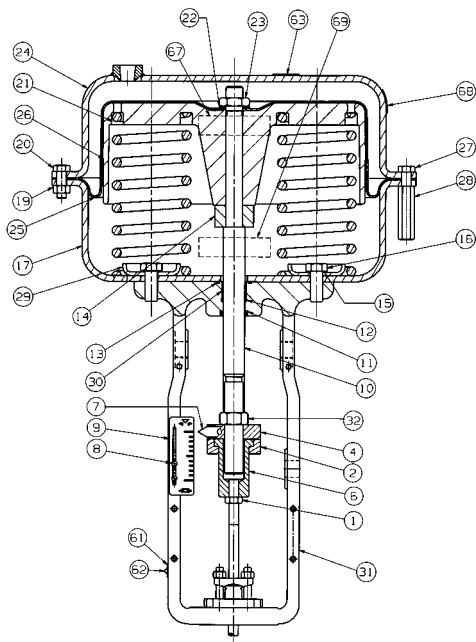

Size 16 Actuator Air to Close (Model 87)

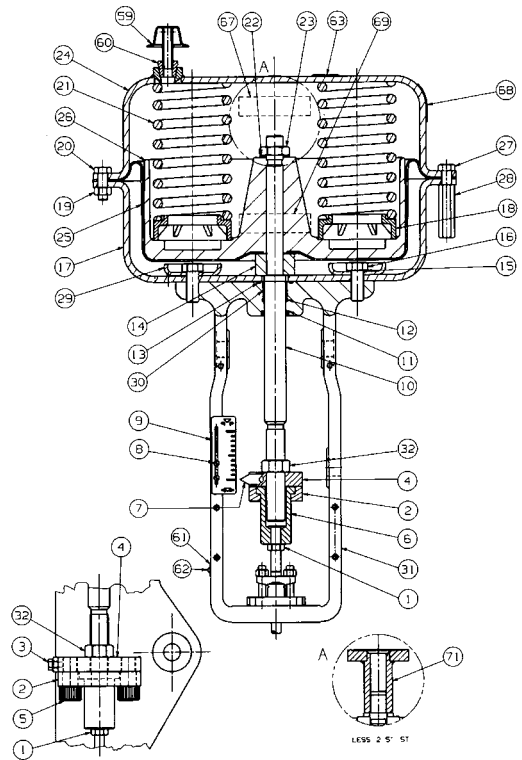

Size 16 Actuator Air to Open
(Model 88)

Materials

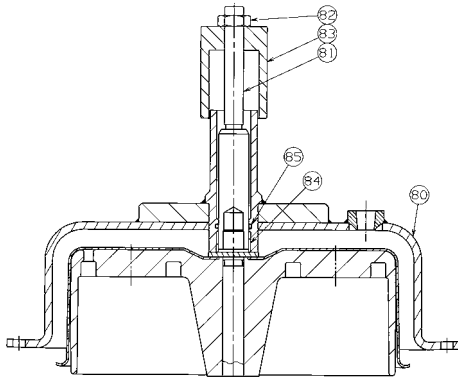

Model 87 - Down Stop
Optional Adjustable Limit Stop

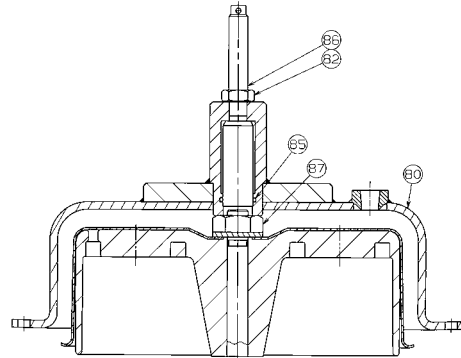

Model 87 - Up Stop
Optional Adjustable Limit Stop

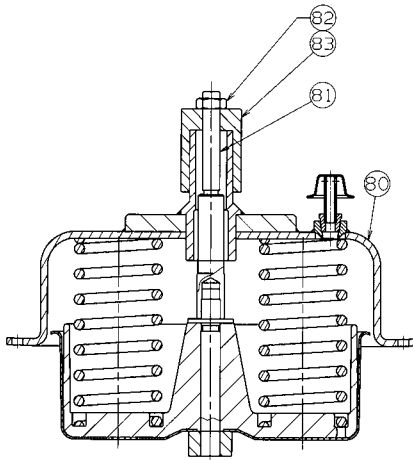

Model 88 - Down Stop
Optional Adjustable Limit Stop

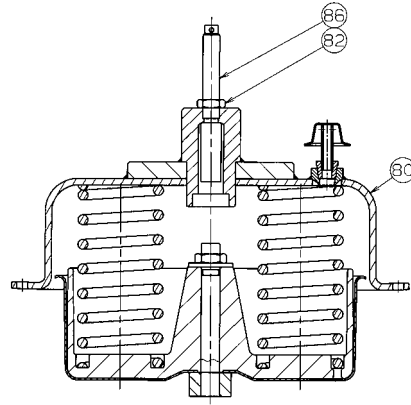

Model 88 - Up Stop
Optional Adjustable Limit Stop

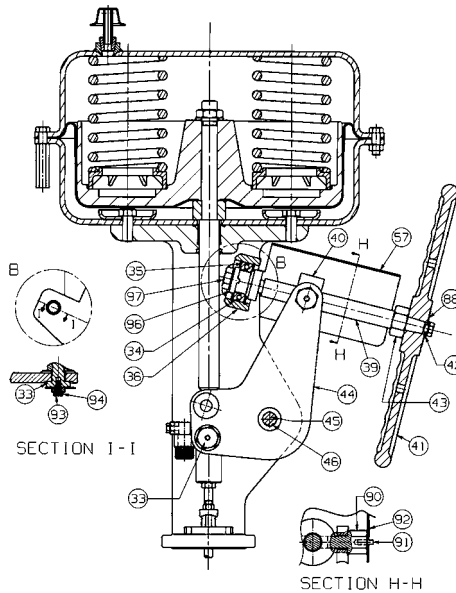

Size 23 Actuator with Optional Handwheel

Materials

Parts Reference for Actuator Sizes 6,10,16 and 23

Ref No.	Description	Material
1	Lock Nut	Carbon Steel
2	Stem Connector-Bottom	Carbon Steel, Zinc Plate
3	Cap Screw-Pointer	Carbon Steel
4	Stem Connector-Top	Carbon Steel, Zinc Plate
5	Cap Screw-Connector	Carbon Steel
6	Connector Insert	Carbon Steel, Zinc Plate
7	Pointer	Stainless Steel
8	Screw-Pan Head	Carbon Steel
9	Scale-Travel	Stainless Steel
10	Actuator Stem	Stainless Steel
11	Stem Wiper	Polyurethane
12	Oring	Buna-N
13	Oring	Buna-N
14	Spacer	Carbon Steel, Zinc Plate
15	Seal Washer	Steel & Rubber
16	Cap Screw-Yoke	Carbon Steel
17	Lower Diaphragm Case	Carbon Steel
18	Spring Spacer	Carbon Steel
19	Hex Nut	Carbon Steel
20	Cap Screw-Hex Head	Carbon Steel
21	Spring	Carbon Steel
22	Washer Flat	Carbon Steel
23	Nut-Jam	Carbon Steel
24	Upper Diaphragm Case	Carbon Steel
25	Diaphragm	Buna-N/Polyester
26	Diaphragm Plate	Aluminum Alloys
27	Cap Screw-Comp	Carbon Steel
28	Compression Nut	Carbon Steel
29	Spring Guide	Carbon Steel
30	Bushing	PTFE/Steel
31	Yoke	Cast Iron
32	Lock Nut	Carbon Steel
33	Pivot Pin	Carbon Steel, Zinc Plate
34	Thrust Bearing	Carbon Steel
35	Retaining Ring	Carbon Steel

Ref No.	Description	Material
36	HW Pivot	Carbon Steel
37	Bearing Ring	Carbon Steel
38	Retaining Ring	Carbon Steel
39	HW Stem	Carbon Steel, Zinc Plate
40	Traveling Nut	Leaded Steel
41	Handwheel	Cast Iron
42	Washer-Flat	Carbon Steel
43	HW Limitation Nut	Carbon Steel, Zinc Plate
44	HW Lever	Carbon Steel
45	Lever Pin	Carbon Steel, Zinc Plate
46	Retaining Ring-Lever Pin	Carbon Steel
57	HW Cover	Carbon Steel
59	Vent Plug	Carbon Steel
60	Pipe Fitting	Carbon Steel, Zinc Plate
63	Information Label	Vinyl
67	Warning Label	Vinyl
68	Warning Label	Vinyl
69	Warning Label	Vinyl
71	Travel Stop	Carbon Steel, Zinc Plate
80	Upper Diaphragm Case	Carbon Steel
81	Stem Extension	Stainless Steel
82	Lock Nut	Stainless Steel
83	Limit Stop	Stainless Steel
84	Bushing	Steel/PTFE Lined
85	Oring	Buna-N
86	Stopper	Stainless Steel
87	Stopper	Carbon Steel
88	Plate-Rotation Arrow	Stainless Steel
90	Pivot Pin-HW Lock	Carbon Steel, Zinc Plate
91	Handwheel Lock Pin	Stainless Steel
92	Information Plate-HW	Vinyl
93	Cap Screw-Hex Head	Carbon Steel
94	Washer-Flat	Carbon Steel
96	End Flange	Carbon Steel, Zinc Plate
97	Cap Screw-HW Stem	Carbon Steel

Dimensions and Weights (U.S.)

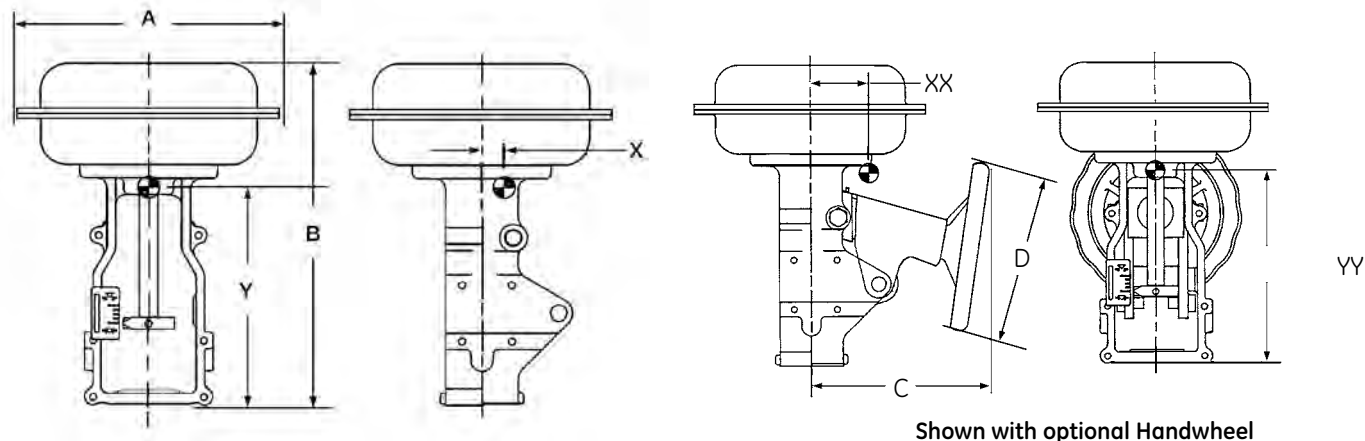

Dimensions and Weights

Actuator Size	Actuator Dimensions (inches)				Weights (lbs.)	
	A	B (Model 88)	C	D	Standard	w/Handwheel
6	11.50	15.54 (17.52)	10.00	9.00	45	60
10	14.50	19.58 (21.54)	10.90	12.00	85	105
16	18.75	28.22 (30.79)	14.00	18.00	210	245
23	21.63	30.71 (33.27)	16.00	18.00	265	320

Actuator Removal Clearance = 6 inches

Center of Gravity (inches)
Without Handwheel

Size	X	Y
6	.19	9.75
10	.0	12.88
16	.13	18.50
23	.06	21.13

With Handwheel

Size	XX	YY
6	1.25	9.13
10	0.88	12.00
16	1.38	16.75
23	1.38	19.00

Limit Stops (inches)

Up Stop

Size	Model	Overall Height B
6	87	19.45
10		25.43
16		36.42
23		38.84
6	88	19.16
10		25.06
16		35.48
23		38.65

Down Stop

Size	Model	Overall Height B
6	87	19.80
10		25.98
16		37.20
23		39.90
6	88	19.74
10		25.85
16		37.46
23		40.33

Dimensions and Weights (Metric)

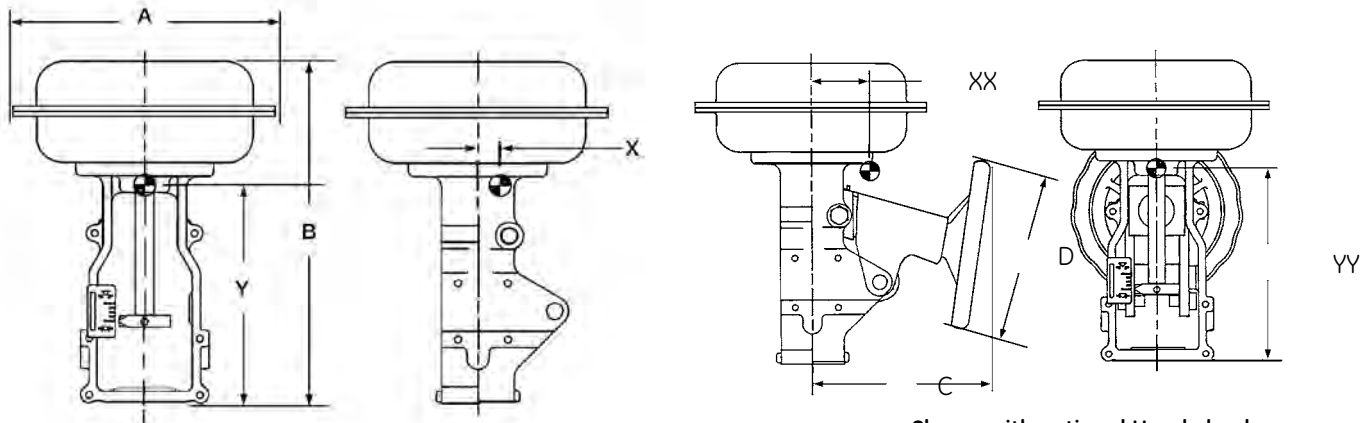

Dimensions and Weights

Shown with optional Handwheel

Actuator Size	Actuator Dimensions (mm)				Weights (kg)	
	A	B (Model 88)	C	D	Standard	w/Hand-wheel
6	302	395 (445)	254	229	20	27
10	373	497 (547)	277	305	39	48
16	476	717 (782)	356	457	95	111
23	549	780 (845)	406	457	120	145

Actuator Removal Clearance = 127 MM

Center of Gravity (mm)
Without Handwheel

Size	X	Y
6	5	248
10	0	327
16	3	470
23	2	537

With Handwheel

Size	XX	YY
6	32	232
10	22	305
16	35	425
23	35	483

Limit Stops (mm)
Up Stop

Size	Model	Overall Height B
6	87	494
10		646
16		925
23		987
6	88	487
10		636
16		901
23		982

Down Stop

Size	Model	Overall Height B
6	87	503
10		660
16		945
23		1014
6	88	501
10		657
16		952
23		1024

DIRECT SALES OFFICE LOCATIONS

BELGIUM

Phone: +32-2-344-0970
Fax: +32-2-344-1123

BRAZIL

Phone: +55-11-2146-3600
Fax: +55-11-2146-3610

CHINA

Phone: +86-10-8486-4515
Fax: +86-10-8486-5305

FRANCE

Courbevoie
Phone: +33-1-4904-9000
Fax: +33-1-4904-9010

GERMANY

Ratingen
Phone: +49-2102-108-0
Fax: +49-2102-108-111

INDIA

Mumbai
Phone: +91-22-8354790
Fax: +91-22-8354791

New Delhi

Phone: +91-11-2-6164175
Fax: +91-11-5-1659635

ITALY

Phone: +39-081-7892-111
Fax: +39-081-7892-208

JAPAN Chiba

Phone: +81-43-297-9222
Fax: +81-43-299-1115

KOREA

Phone: +82-2-2274-0748
Fax: +82-2-2274-0794

MALAYSIA

Phone: +60-3-2161-0322
Fax: +60-3-2163-6312

MEXICO

Phone: +52-5-310-9863
Fax: +52-5-310-5584

THE NETHERLANDS

Phone: +0031-15-3808666
Fax: +0031-18-1641438

RUSSIA

Veliky Novgorod
Phone: +7-8162-55-7898
Fax: +7-8162-55-7921

Moscow

Phone: +7 495-585-1276
Fax: +7 495-585-1279

SAUDI ARABIA

Phone: +966-3-341-0278
Fax: +966-3-341-7624

SINGAPORE

Phone: +65-6861-6100
Fax: +65-6861-7172

SOUTH AFRICA

Phone: +27-11-452-1550
Fax: +27-11-452-6542

SOUTH and CENTRAL

AMERICA and the CARIBBEAN
Phone: +55-12-2134-1201
Fax: +55-12-2134-1238

SPAIN

Phone: +34-93-652-6430
Fax: +34-93-652-6444

UNITED ARAB EMIRATES

Phone: +971-4-8991-777
Fax: +971-4-8991-778

UNITED KINGDOM

Wooburn Green
Phone: +44-1628-536300
Fax: +44-1628-536319

UNITED STATES

Massachusetts
Phone: +1-508-586-4600
Fax: +1-508-427-8971

Corpus Christi, Texas

Phone: +1-361-881-8182
Fax: +1-361-881-8246

Deer Park, Texas

Phone: +1-281-884-1000
Fax: +1-281-884-1010

Houston, Texas

Phone: +1-281-671-1640
Fax: +1-281-671-1735



* Masoneilan is a registered trademark of the General Electric Company.
Other company names and product names used in this document are the registered trademarks
or trademarks of their respective owners.

© 2013 General Electric Company. All rights reserved.

GEA19711 05/2013