

8000 SERIES

MONOVEYORS

January, 2009

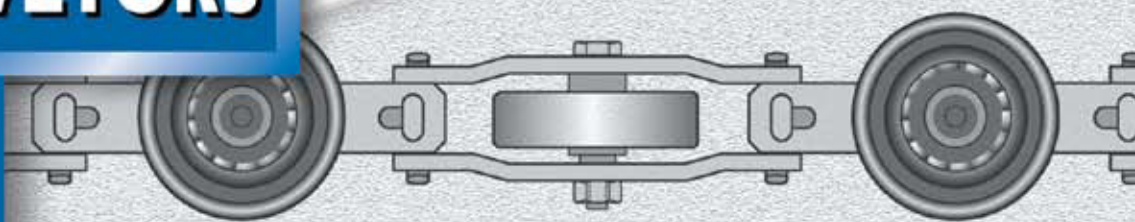

Founded in 1958 in Pickering, Ontario, Allied Conveyors Limited established a reputation as an industry leader in the design, manufacture and installation of premium quality materials handling systems. Recently acquired by interests in the United States, the company now operates under the name Allied Conveyor Systems, Inc. and proudly continues the 50 year old company traditions from Statham, Georgia.

We offer a wide variety of overhead conveyors that are suitable for various applications, from paint finish and processing, to in-line and flexible assembly operations in the automotive, electronic, agriculture, and many other industries. Our conveyors have also established a strong presence for distribution and warehousing applications.



ENCLOSED TRACK

This track is a square, tubular section composed of AISI-SAE 1030 high carbon manganese steel.

- Stocked in 20' 0" lengths
- Can be saw-cut and welded without any special equipment
- End plates can be supplied for bolted installation
- All external surfaces of track are painted grey-blue metallic
- Available in stainless steel (special order)

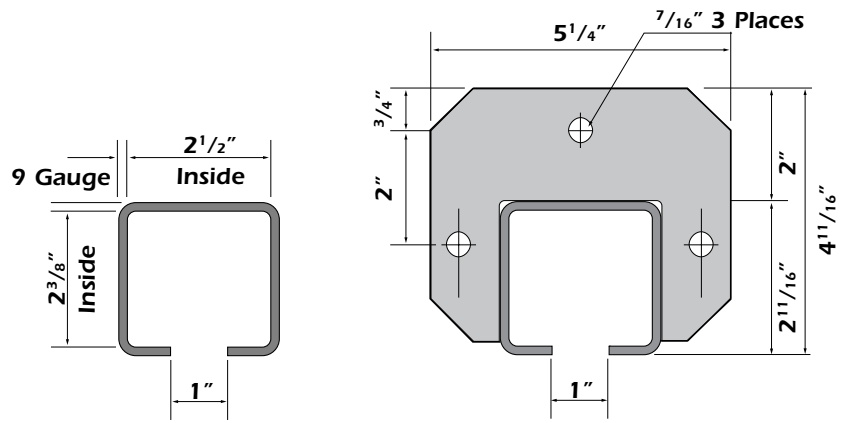

AC 8001 STRAIGHT TRACK SECTION
Weight: 5 lbs per ft.

AC 0868 END PLATE FOR BOLTED CONSTRUCTION

MASTER CONNECTING LINK ASSEMBLY:

This assembly should be used when the chain must be joined in a straight line.

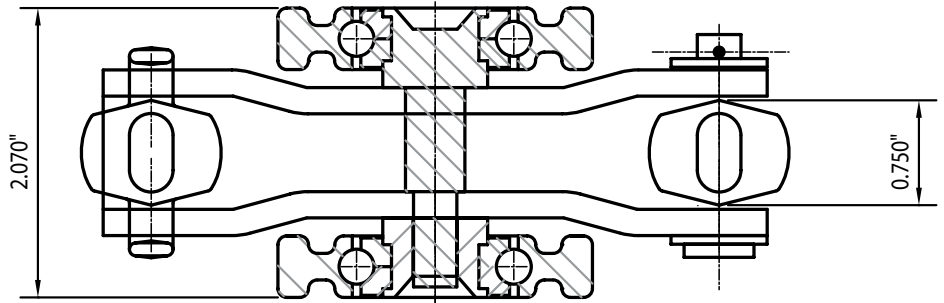

AC 8369 CONNECTING LINK ASSEMBLY

CHAIN PULL:

The ultimate tensile strength of this chain pull is 11,500 pounds. For maximum chain life, the chain pull should be limited to 750 pounds using a single drive unit, which provides a safety factor of 15 to 1.

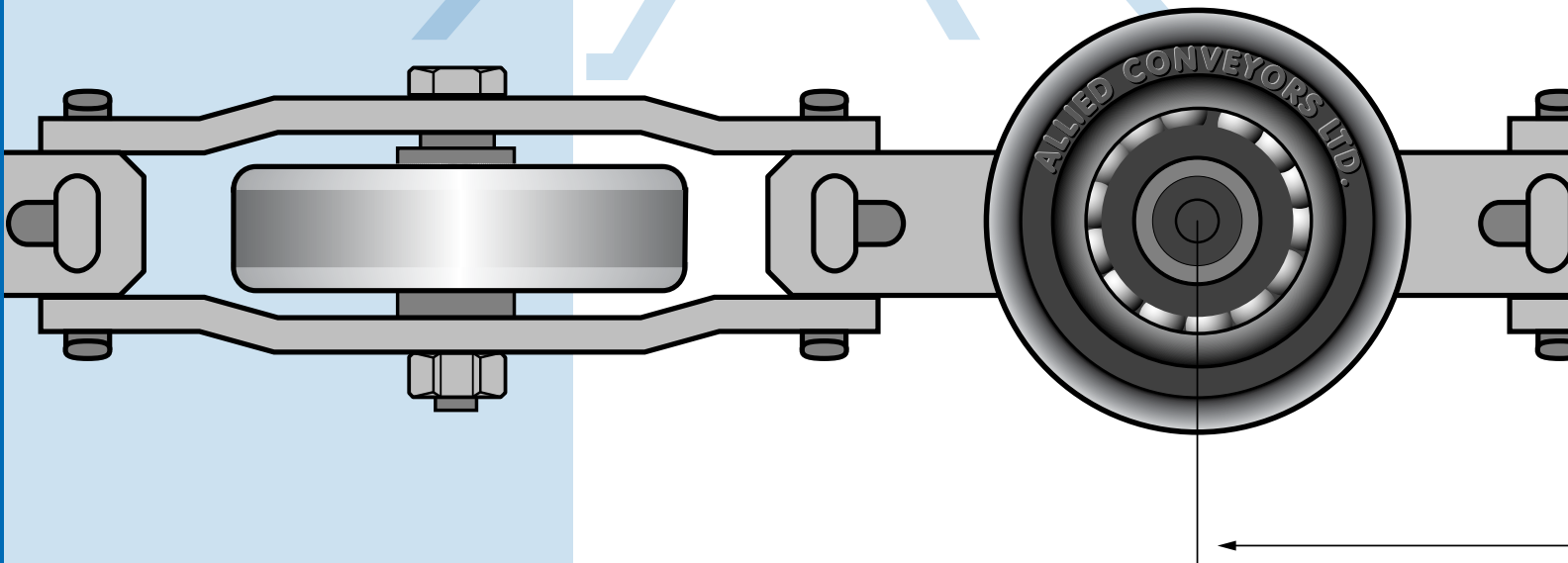

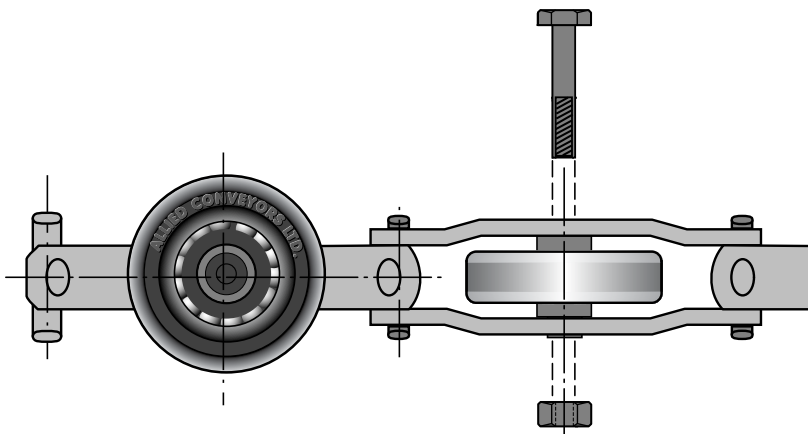

AC 8368 CHAIN ASSEMBLY
Weight: 3.25 lbs per ft.

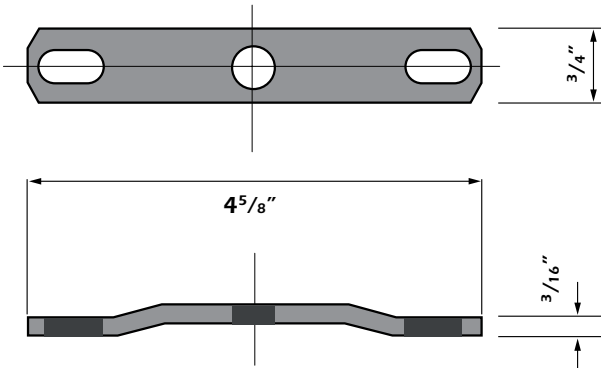

AC 0935 CHAIN SIDE BAR

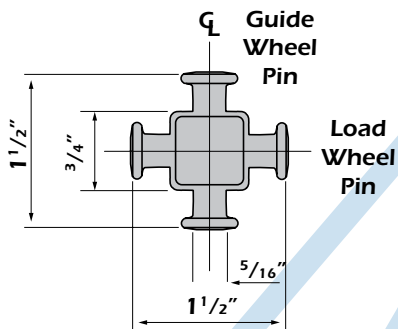

AC 0936 CHAIN PIN SYMETRICAL

ASSEMBLY:

The chain can be readily disassembled at every pitch by removing the axle bolt on the side guide wheel and rotating the link 90 degrees.

SIDE BARS – CHAIN LINK:

These chain side bars are formed of AISI-SAE 1045 high carbon steel. They are then through-hardened and tempered to Rockwell 37-47 "C" scale.

CHAIN PINS:

These pins are drop-forged from AISI-SAE 1045 high carbon steel and heat treated to Rockwell 36-42 "C" scale. This universal pin allows the chain to flex in both directions.

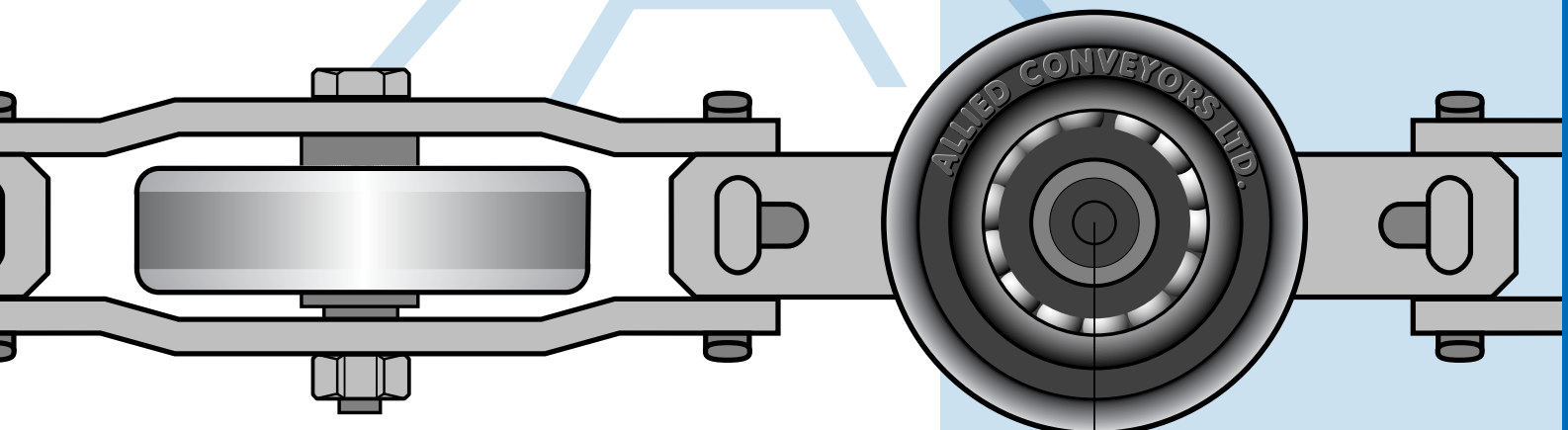

8" Nominal Pitch (8 1/8" Pitch)

LOAD WHEELS:

Each pair of load wheels measure 2.25" in diameter, with 7/16" face width and 14 - .250" diameter carbon steel balls (Grade 500). The wheels are machined from solid stock and heat treated to 58-62 Rockwell "C" scale.

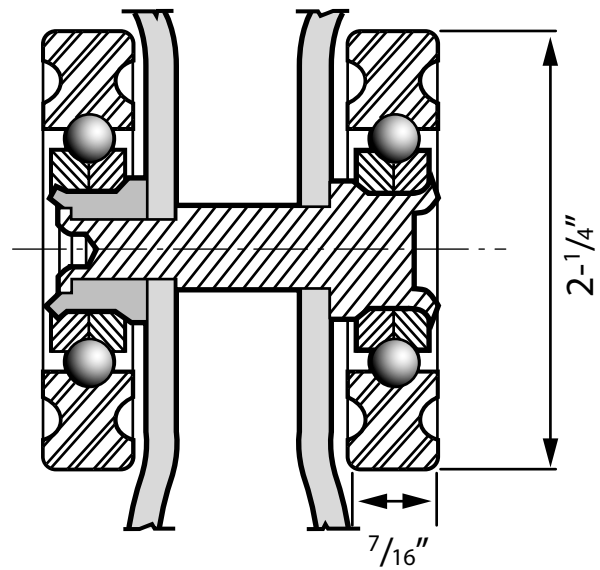

AC 0850-2F LOAD WHEEL

SIDE GUIDE WHEELS:

Each guide wheel is 2.31" in diameter with 14 - .250" diameter carbon steel balls (Grade 500) and a face width of 13/16". The greater face width allows forces to be distributed over a larger area. The wheels are hardened and heat treated to 58-62 Rockwell "C" scale.

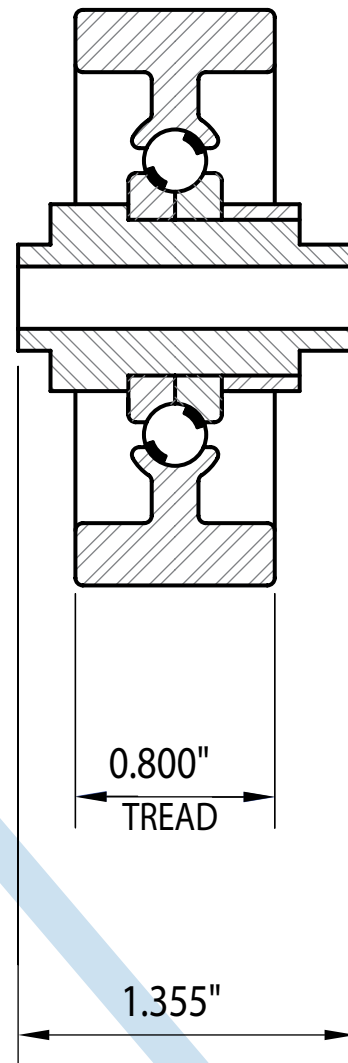

AC 0807-R GUIDE WHEEL

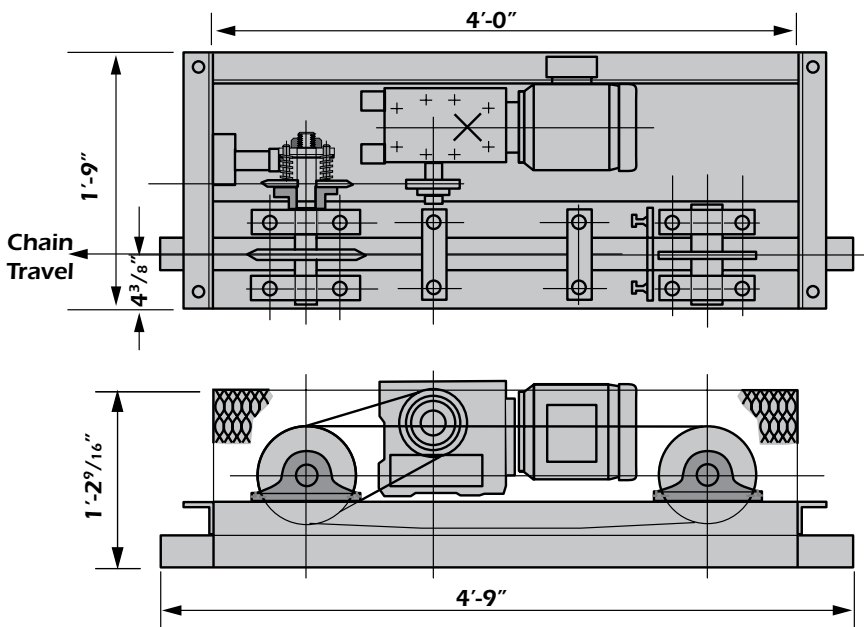

AC 8021 VARIABLE SPEED CAT DRIVE
AC 8022 CONSTANT SPEED CAT DRIVE
 Weight: 350 lbs

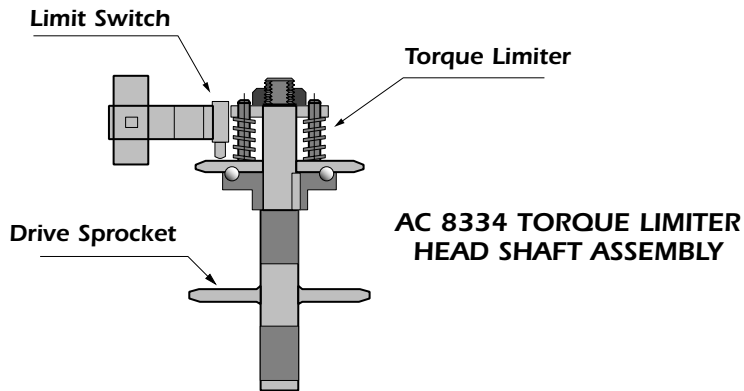

AC 8334 TORQUE LIMITER HEAD SHAFT ASSEMBLY

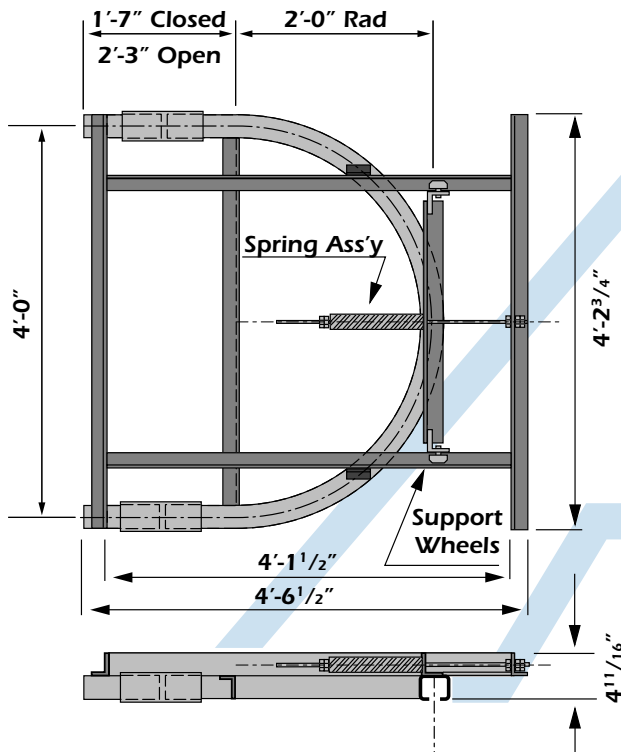

AC 8012 2'-0" R HOR. 8" TRAVEL SPRING T.U.
 Weight: 155 lbs

DRIVE:

- Maximum chain pull capacity 750 pounds.
- Standard variable 5 to 1 speed range, no exposed belts or pulleys.
- Combination right angle (helical worm) reducers.
- Eleven fixed heat treated caterpillar driving dogs.
- Chain guard supplied with each drive.
- Multiple drives are required when chain pull exceeds 750 pounds.
- Variable frequency drive controller available on request.
- Maximum conveyor speed should not exceed 60 f.p.m. with standard drive sprockets.

ALLIED TORQUE LIMITER

The Allied Torque Limiter supplies overload protection when used with a limit switch to cut off power.

TAKE-UP

A take-up is required on every system to compensate for chain stretch, wear, and chain expansion of the system if operating in dry off or bake ovens.

Take-ups are used with four different types of adjustments: manual screws, automatic spring, air cylinder and counterweighted.

The standard radius of a take-up is 2'0", resulting in a 4'0" width; however, variable radii and spreads can be supplied to suit special requirements.

CHAIN INSPECTION GATE:

This section of track with a hinged panel is designed for chain inspection and maintenance.

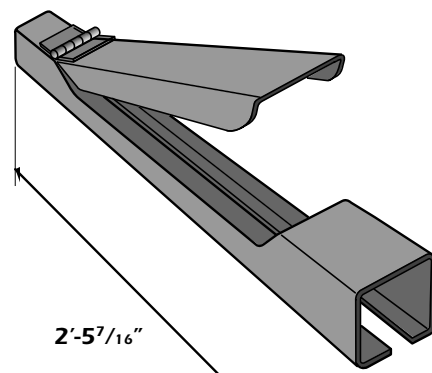

2'-5⁷/₁₆"

CHAIN INSTALLATION GATE:

This track section is supplied to ease chain installation and removal.

AC 8032 INSPECTION GATE

Weight: 12 lbs

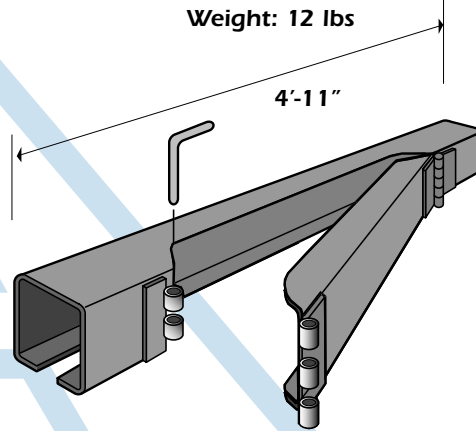

4'-11"

AC 8031 INSTALLATION GATE

Weight: 12 lbs

ANTI-BACKUP SAFETY STOP:

In the unlikely event of chain failure, anti-back-up safety stops are recommended on any loaded inclines of approximately 5' 0" drop or more. These stops will prevent runaway action caused by the loose chain.

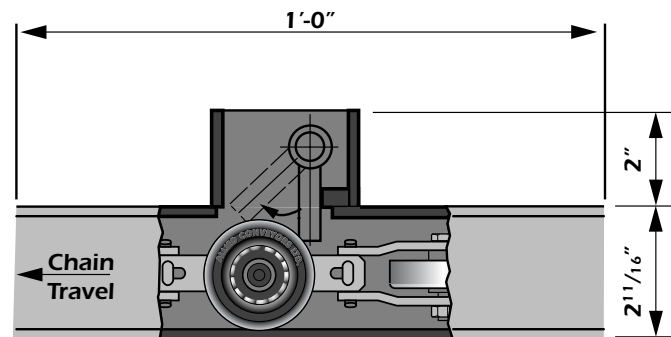

AC 8033 ANTI-BACKUP STOP ASSEMBLY

Weight: 2 lbs

ANTI-RUNAWAY SAFETY STOP:

Anti-runaway safety stops are recommended on any loaded decline of approximately 5' 0" drop or more. The stop is activated by the conveyor chain accelerating beyond its design speed. This stop can be supplied with a limit switch cutout.

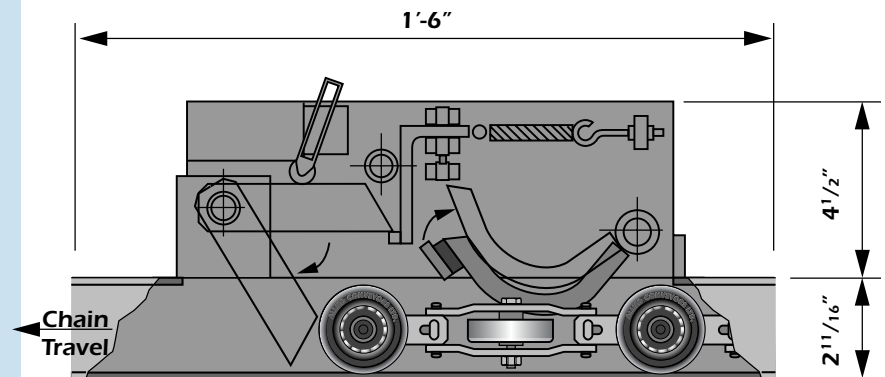

AC 8034 ANTI-RUNAWAY STOP ASSEMBLY

Weight: 15 lbs

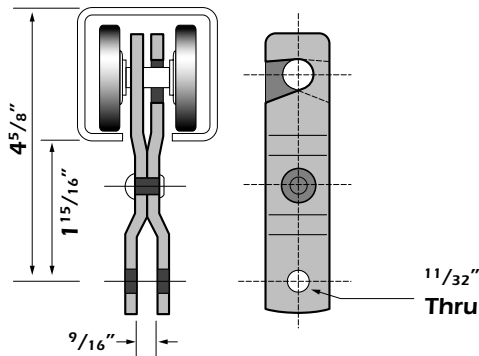

AC 8367 STD "H" ATTACHMENT
Weight: 0.5 lbs

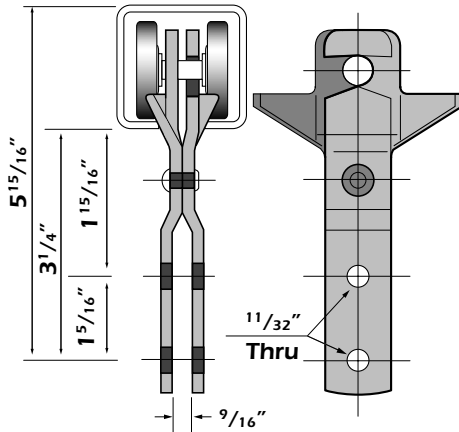

AC 8366 RIGID "H" ATT. ASSEMBLY
Weight: 1 lb

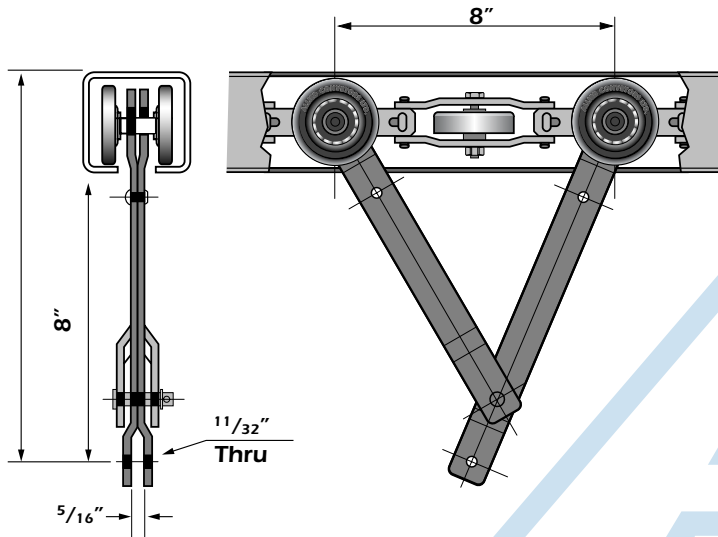

AC 8041 EXTENDED "H" ATTACHMENT
Weight: 2 lbs

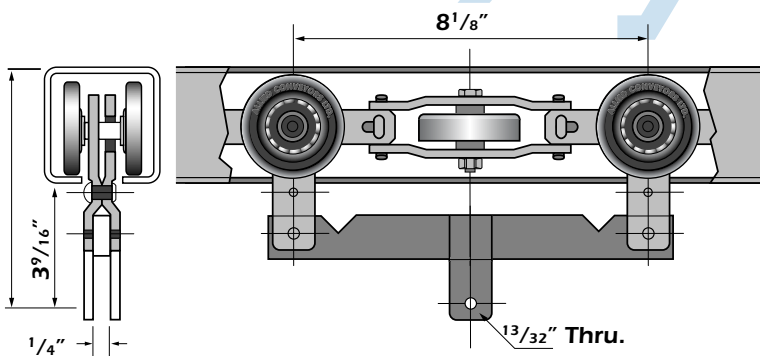

AC 8007 LOAD BAR ASSEMBLY

STANDARD "H" ATTACHMENTS:
(Capacity 125 pounds)

The standard "H" attachment attaches directly to the chain load wheel axle. The scissor-like action allows for easy installation anywhere on the line and is locked into position by the carrier clevis bolt.

RIGID "H" ATTACHMENT:
(Capacity 75 Pounds)

When installed, this attachment remains perpendicular to the chain at all times. The additional clevis hole allows the carrier to stay fixed in a rigid position.

EXTENDED "H" ATTACHMENT:
(Capacity 125 Pounds)
(Minimum Radius 24")

This attachment is primarily used on conveyors with vertical travel to hold the load or carrier away from the track.

LOAD BAR:
(Capacity 200 Pounds)

Load bars suspended from two "H" attachments are recommended for increasing the capacity of trolleys.

TRACK EXPANSION JOINTS:
(Building and Ovens)

Formed steel sliding expansion joints are available for oven conveyors and are usually required where temperatures exceed 200°F.

The rate of expansion of track in ovens is .000078" per foot of length for 1°F of temperature rise.

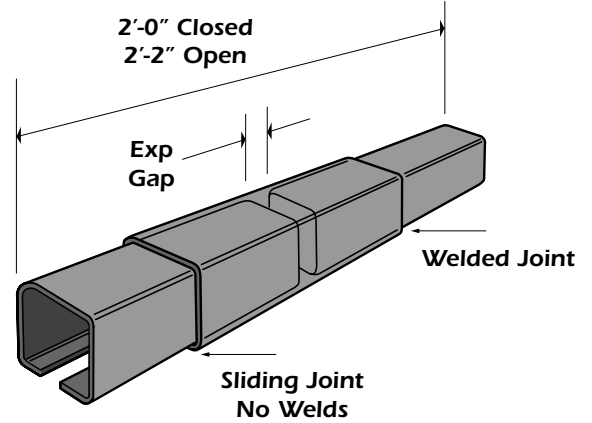

AC 8030 EXPANSION JOINT
Weight: 10 lbs

IN-LINE TRACK CLEANER:

This track cleaner installs in minutes and will become an integral part of the conveyor chain. The unit travels throughout the entire system, automatically cleaning the track.

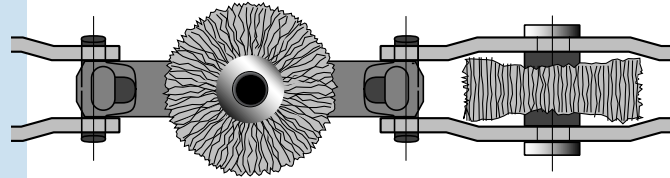

AC 8370
IN-LINE TRACK CLEANER

BRUSH TYPE CHAIN OILER:

This oiler comes in two models: auto shut-off solenoid and manual on-off control. Due to the small quantities of oil required for enclosed track conveyors, timer-controlled units are recommended for the precise application of oil. Manually-controlled oilers are available but not recommended unless continuous lubrication is desired. This oiler comes pre-mounted to a standard track section.

BRUSH TYPE CHAIN OILER

AC 8035
(AUTOMATIC SHUT-OFF)

AC 8036
(MANUAL SHUT-OFF)

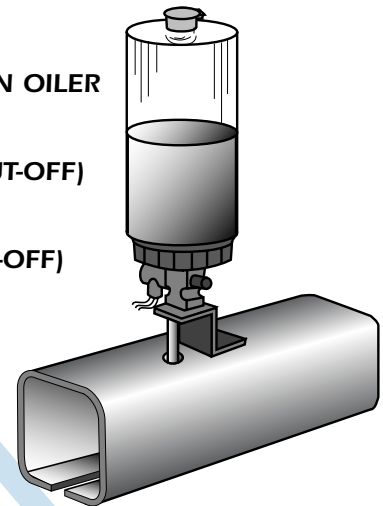

AUTOMATIC 5 POINT LUBRICATOR:

The automatic lubricator is designed to deliver precise oil to chain pins and wheels. It is pneumatically operated and electrically controlled for complete automatic operation. The unit comes fully equipped with an oil reservoir, air line regulator and gauge, and a 168-hour timer, which is used to program lubrication cycles. The lubricator comes pre-mounted to a standard track section.

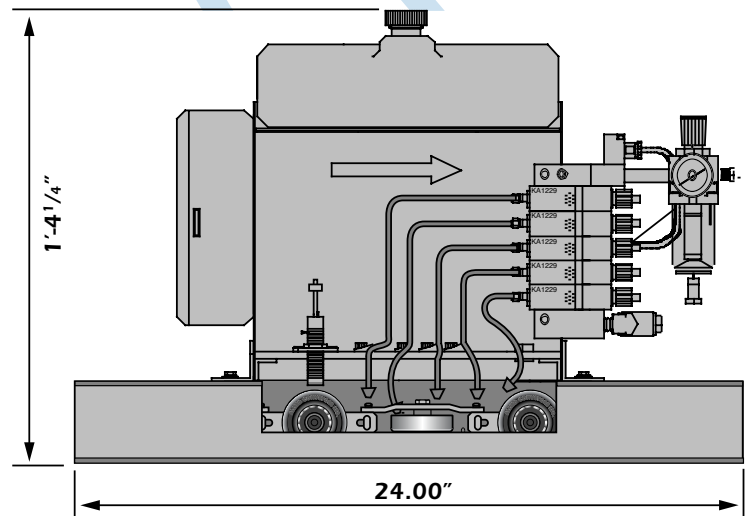

AC 8037 AUTOMATIC 5 POINT LUBRICATOR
Weight: 60 lbs

(WEIGHT: 150 LBS)

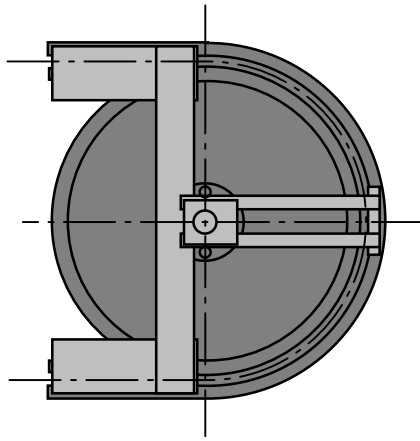

TRACTION WHEELS:

The smallest horizontal track turn available for this conveyor is a 24" radius or 48" diameter. If the system layout requires a smaller diameter turn, special traction wheel assemblies can be supplied that feature 18", 24", 30", or 36" diameters, with carbon graphite or tapered roller bearing to suit the application.

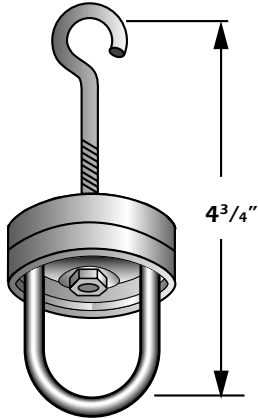

AC 1546 SWIVEL ROTATOR

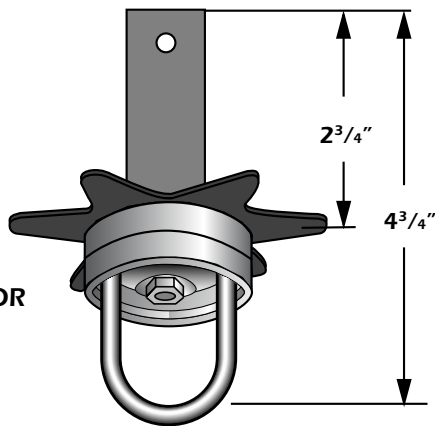

AC 1545 SWIVEL ROTATOR
C/W 6 POINT STAR

SWIVEL ROTATORS:

This free-spinning ball bearing swivel assembly can be rotated by hand or automatically rotated at any point on the system with the installation of a rub rail.

SWIVEL ROTATOR C/W 6 POINT STAR:

The addition of the 6 point star provides positive rotation.

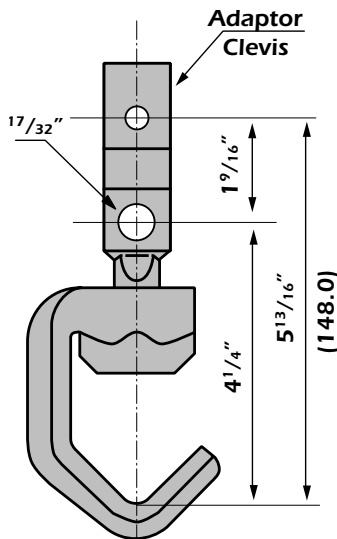

AC 8140
90° INDEXER HOOK
CAPACITY 150 POUNDS

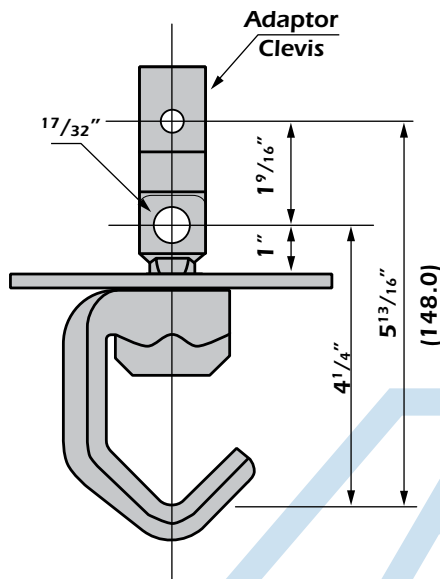

AC 8139
90° INDEXER HOOK
C/W 4 POINT STAR
CAPACITY 150 POUNDS

90 DEGREE INDEXER HOOK:

The cast, two-piece cam construction provides 90 degree indexing.

90 DEGREE INDEXER HOOK C/W 4 POINT STAR:

The addition of the 4 point star to the standard hook allows automatic indexing.

HAND PUSHED TROLLEY ASSEMBLY:
(Capacity 250 Pounds)

Four ball bearing load wheels with hardened races and two hardened side guide rollers mounted to a one-piece, high strength cast body provide long trolley life under adverse conditions.

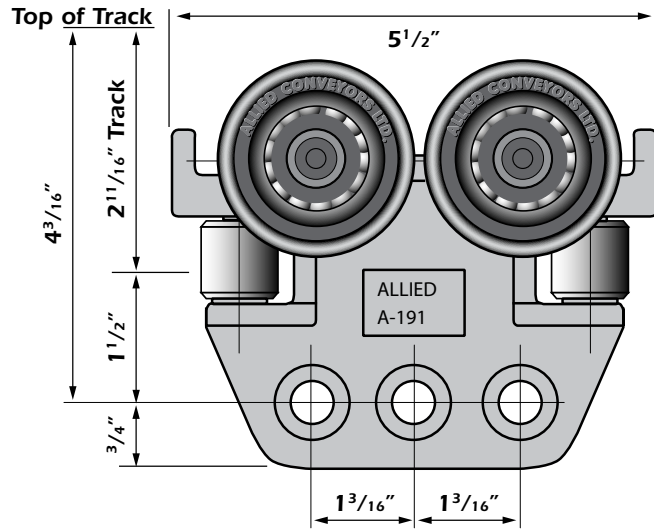

AC 8040 4 WHEEL HAND PUSHED TROLLEY
Weight: 6 lbs

4-WHEEL TROLLEY:
(Capacity 250 pounds)

Four ball bearing load wheels with hardened races can be built into the Allied 8000 series chain to handle heavy loads.

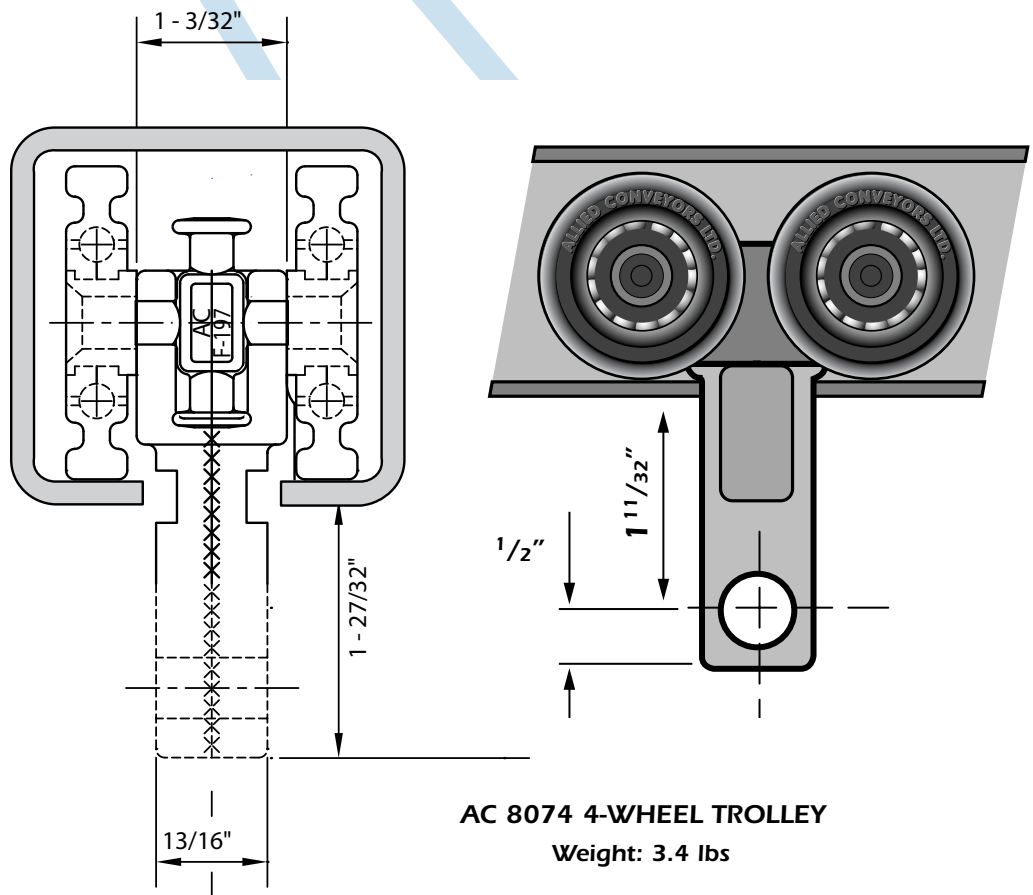

AC 8074 4-WHEEL TROLLEY
Weight: 3.4 lbs

GRAVITY FLOW MONOVEYOR:

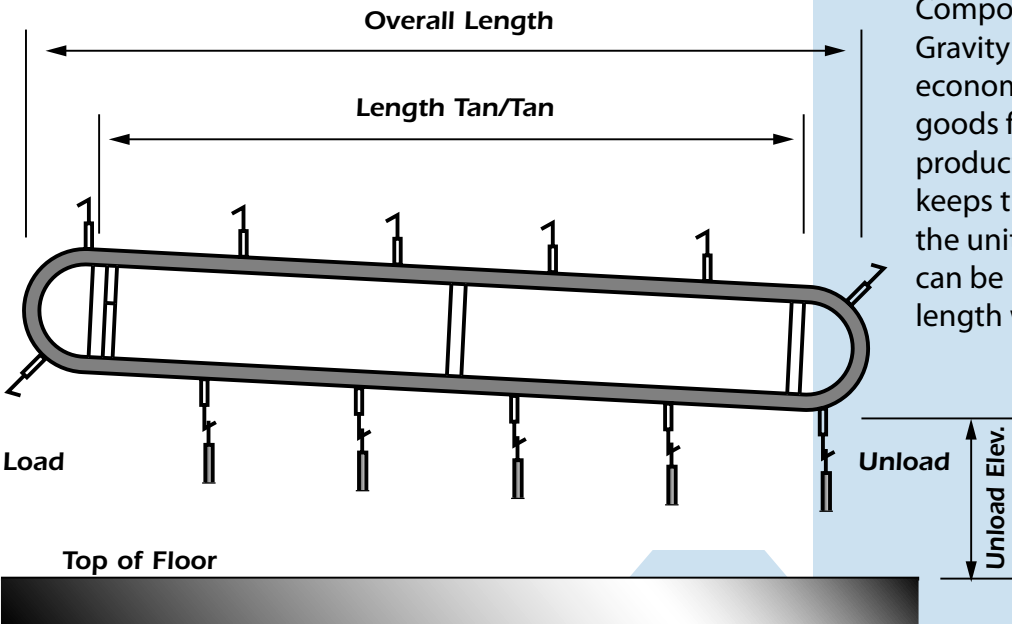

Components can be made up into Gravity Flow Monoveyors for economical storage and transfer of goods from sub-assembly to main production lines. The use of gravity keeps the price and maintenance of the units to a minimum. These units can be pre-assembled up to 40' 0" in length with the chain installed.

GRAVITY FLOW MONOVEYOR

POWERED VERTICAL LOOP:

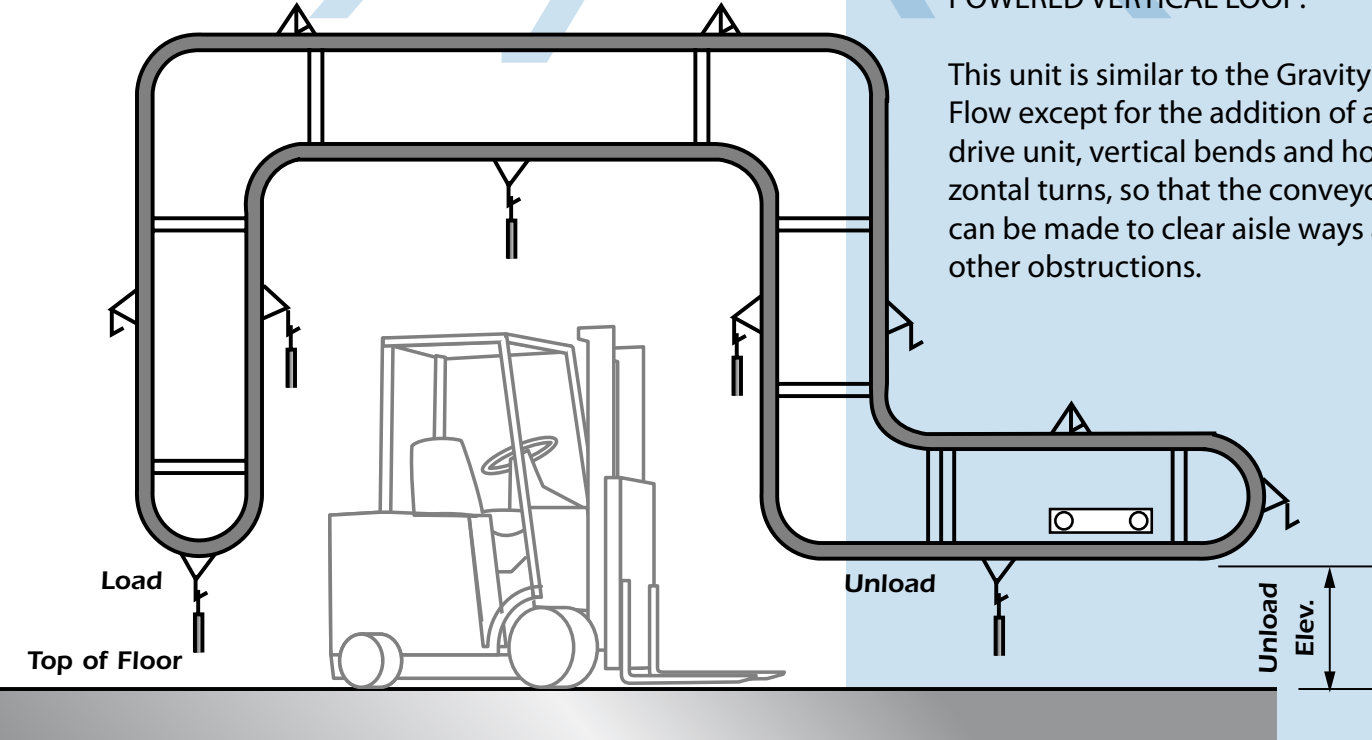

This unit is similar to the Gravity Flow except for the addition of a drive unit, vertical bends and horizontal turns, so that the conveyor can be made to clear aisle ways and other obstructions.

POWERED VERTICAL LOOP CONVEYOR

INVERTED POWER CONVEYOR:

This enclosed track can be inverted to protect product from contamination, thus eliminating the need for sanitary pans. This unit is particularly useful in clean-room applications.

Enclosed track shown inverted and used as a spindle conveyor.

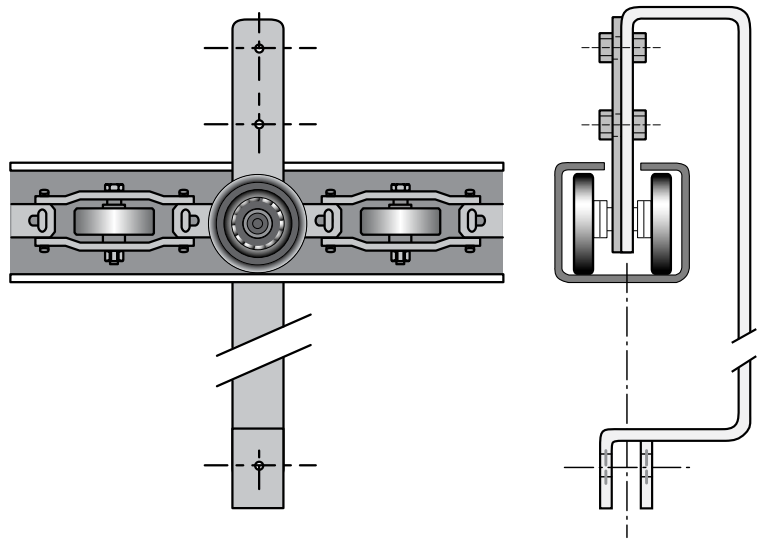

SINGLE INVERTED HANGER
CAPACITY: 125 LBS

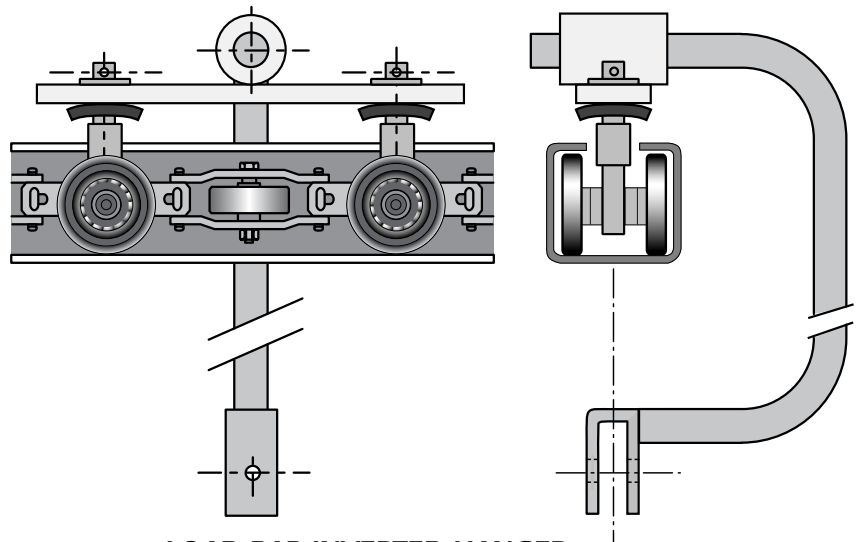

LOAD BAR INVERTED HANGER
CAPACITY: 250 LBS

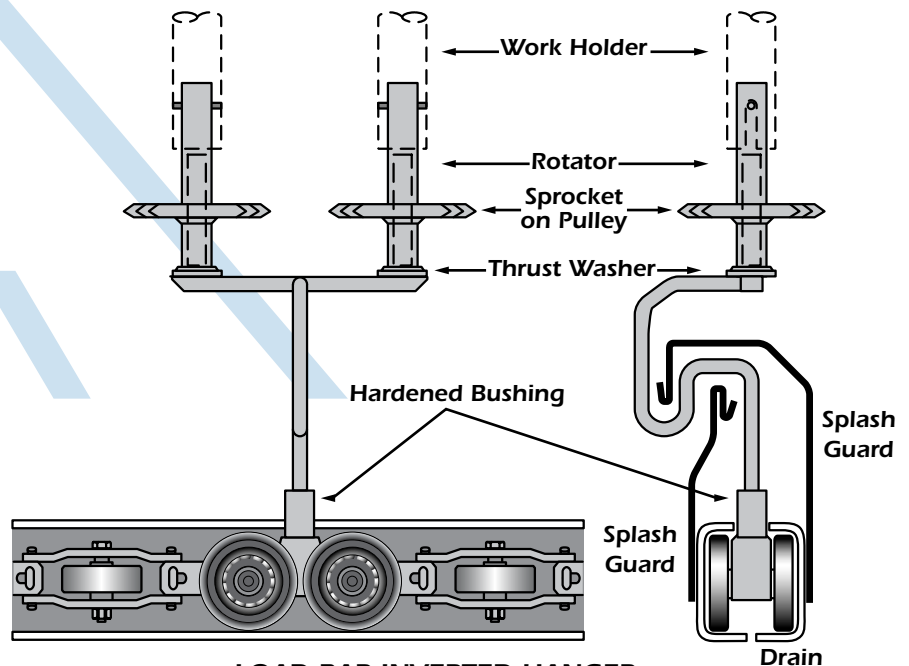

LOAD BAR INVERTED HANGER
CAPACITY: 250 LBS

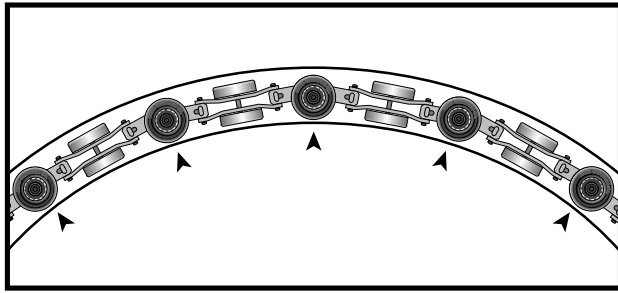

HORIZONTAL TURNS:

This horizontal turn with the top removed illustrates how the chain passes around the curve. The lateral wheels ride on the side of the track, which guides the chain smoothly around a horizontal turn without the use of special guides, traction wheels or roller turns.

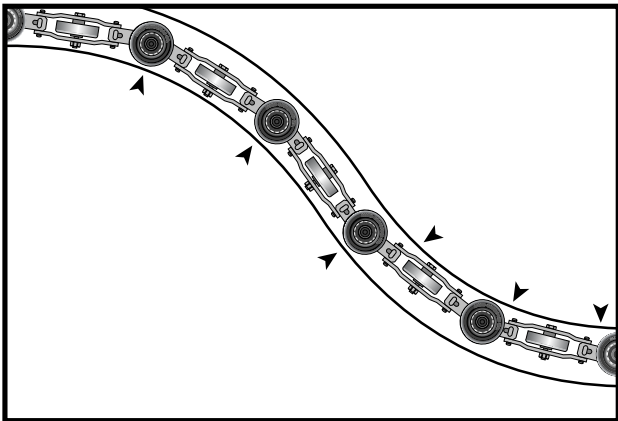

VERTICAL CURVES:

This compound vertical curve with one side removed illustrates how the vertical chain wheels contact the top of the lower curve and the bottom of the upper curve.

STANDARD TRACK CURVES:

All horizontal turns and vertical curves illustrated are available in stock for immediate delivery. Special radius or degree turns can be fabricated to-order. For turns or curves smaller than 24" radius, horizontal traction wheels can be furnished. Both horizontal turns and vertical curves are heat treated to RC35-40 in areas of wheel contact to ensure a hard, tough surface for added anti-wear qualities. Standard turns are fabricated with 8 inches of straight track on each end.

**VERTICAL BENDS
30° CURVE**

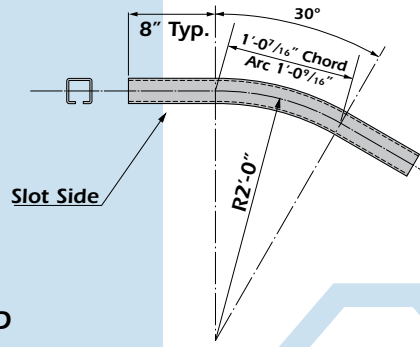
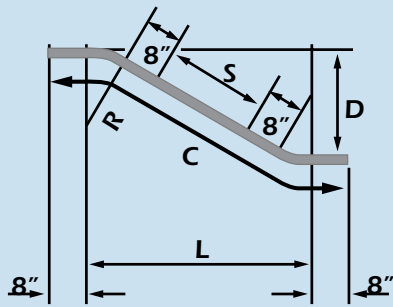

**AC 8026 UPPER VERTICAL
CURVE 2'-0" RAD. X 30°**

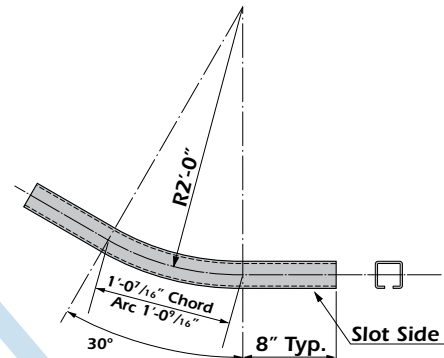

**AC 8029 LOWER VERTICAL
CURVE 2'-0" RAD. X 30°**

2'0" RADIUS X 30 DEGREES

DROP	S	L	C
1'-2-3/8"	0	3'-1-7/8"	4'-9-1/8"
1'-6"	0'-7-1/8"	3'-8"	5'-4-1/4"
1'-9"	1'-1-1/8"	4'-1-1/4"	5'-10-1/4"
2'-0"	1'-7-1/8"	4'-6-3/8"	6'-4-1/4"
2'-3"	2'-1-1/8"	4'-11-5/8"	6'-10-1/4"
2'-6"	2'-7-1/8"	5'-4-7/8"	7'-4-1/4"
2'-9"	3'-1-1/8"	5'-10"	7'-10-1/4"
3'-0"	3'-7-1/8"	6'-3-1/4"	8'-4-1/4"
3'-6"	4'-7-1/8"	7'-1-5/8"	9'-4-1/4"
4'-0"	5'-7-1/8"	8'-0"	10'-4-1/4"
4'-6"	6'-7-1/8"	8'-10-3/8"	11'-4-1/4"
5'-0"	7'-7-1/8"	9'-8-3/4"	12'-4-1/4"
5'-6"	8'-7-1/8"	10'-7-1/8"	13'-4-1/4"
6'-0"	9'-7-1/8"	11'-5-5/8"	14'-4-1/4"
6'-6"	10'-7-1/8"	12'-4"	15'-4-1/4"
7'-0"	11'-7-1/8"	13'-2-3/8"	16'-4-1/4"
7'-6"	12'-7-1/8"	14'-0-3/4"	17'-4-1/4"
8'-0"	13'-7-1/8"	14'-11-1/8"	18'-4-1/4"
8'-6"	14'-7-1/8"	15'-9-1/2"	19'-4-1/4"
9'-0"	15'-7-1/8"	16'-7-7/8"	20'-4-1/4"
9'-6"	16'-7-1/8"	17'-6-3/8"	21'-4-1/4"
10'-0"	17'-7-1/8"	18'-4-3/4"	22'-4-1/4"
10'-6"	18'-7-1/8"	19'-3-1/8"	23'-4-1/4"
11'-0"	19'-7-1/8"	20'-1-1/2"	24'-4-1/4"
11'-6"	20'-7-1/8"	20'-11-7/8"	25'-4-1/4"
12'-0"	21'-7-1/8"	21'-10-1/4"	26'-4-1/4"
12'-6"	22'-7-1/8"	22'-8-5/8"	27'-4-1/4"

3'0" RADIUS X 30 DEGREES

DROP	S	L	C
1'-5-5/8"	0	4'-1-7/8"	5'-9-3/4"
1'-9"	0'-6-3/4"	4'-7-5/8"	6'-4-3/8"
2'-0"	1'-0-3/4"	5'-0-7/8"	6'-10-3/8"
2'-3"	1'-6-3/4"	5'-6"	7'-4"
2'-6"	2'-0-3/4"	5'-11-1/4"	7'-10-3/8"
2'-9"	2'-6-3/4"	6'-4-1/2"	8'-4-3/8"
3'-0"	3'-0-3/4"	6'-9-5/8"	8'-10-3/8"
3'-6"	4'-0-3/4"	7'-8"	9'-10-3/8"
4'-0"	5'-0-3/4"	8'-6-3/8"	10'-10-3/8"
4'-6"	6'-0-3/4"	9'-4-7/8"	11'-10-3/8"
5'-0"	7'-0-3/4"	10'-3-1/4"	12'-10-3/8"
5'-6"	8'-0-3/4"	11'-1-5/8"	13'-10-3/8"
6'-0"	9'-0-3/4"	12'-0"	14'-10-3/8"
6'-6"	10'-0-3/4"	12'-10-3/8"	15'-10-3/8"
7'-0"	11'-0-3/4"	13'-8-3/4"	16'-10-3/8"
7'-6"	12'-0-3/4"	14'-7-1/8"	17'-10-3/8"
8'-0"	13'-0-3/4"	15'-5-5/8"	18'-10-3/8"
8'-6"	14'-0-3/4"	16'-4"	19'-10-3/8"
9'-0"	15'-0-3/4"	17'-2-3/8"	20'-10-3/8"
9'-6"	16'-0-3/4"	18'-0-3/4"	21'-10-3/8"
10'-0"	17'-0-3/4"	18'-11-1/8"	22'-10-3/8"
10'-6"	18'-0-3/4"	19'-9-1/2"	23'-10-3/8"
11'-0"	19'-0-3/4"	20'-7-7/8"	24'-10-3/8"
11'-6"	20'-0-3/4"	21'-6-3/8"	25'-10-3/8"
12'-0"	21'-0-3/4"	22'-4-3/4"	26'-10-3/8"
12'-6"	22'-0-3/4"	23'-3-1/8"	27'-10-3/8"

NOTE: All horizontal and vertical turns are heat treated on the contact surface to RC35-40.

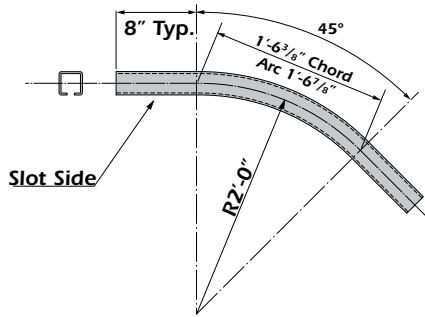

AC 8025 UPPER VERTICAL CURVE 2'-0" RAD. X 45°

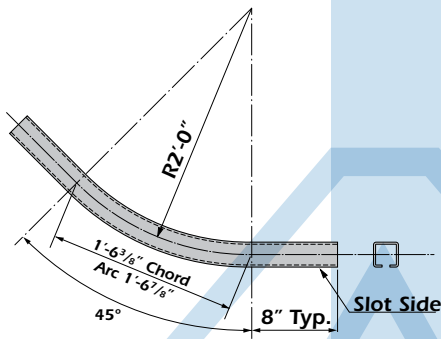

AC 8028 LOWER VERTICAL CURVE 2'-0" RAD. X 45°

**VERTICAL BENDS
45° CURVE**

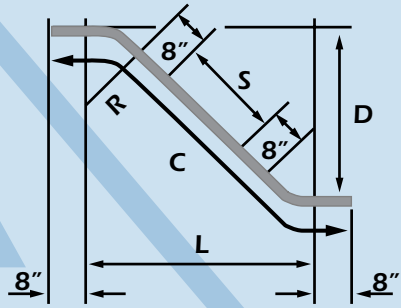

2'0" RADIUS X 45 DEGREES

DROP	S	L	C
2'-3"	0'-2-1/4"	3'-10-7/8"	6'-0"
2'-6"	0'-6-1/2"	4'-1-7/8"	6'-4-1/4"
2'-9"	0'-10-3/4"	4'-4-7/8"	6'-8-1/2"
3'-0"	1'-3"	4'-7-7/8"	7'-0-3/4"
3'-6"	1'-11-1/2"	5'-1-7/8"	7'-9-1/4"
4'-0"	2'-8"	5'-7-7/8"	8'-5-3/4"
4'-6"	3'-4-1/2"	6'-1-7/8"	9'-2-1/8"
5'-0"	4'-1"	6'-7-7/8"	9'-10-5/8"
5'-6"	4'-9-1/2"	7'-1-7/8"	10'-7-1/8"
6'-0"	5'-6"	7'-7-7/8"	11'-3-5/8"
6'-6"	6'-2-3/8"	8'-1-7/8"	12'-0-1/8"
7'-0"	6'-10-7/8"	8'-7-7/8"	12'-8-5/8"
7'-6"	7'-7-3/8"	9'-1-7/8"	13'-5-1/8"
8'-0"	8'-3-7/8"	9'-7-7/8"	14'-1-5/8"
8'-6"	9'-0-3/8"	10'-1-7/8"	14'-10-1/8"
9'-0"	9'-8-7/8"	10'-7-7/8"	15'-6-1/2"
9'-6"	10'-5-3/8"	11'-1-7/8"	16'-3"
10'-0"	11'-1-7/8"	11'-7-7/8"	16'-11-1/2"
10'-6"	11'-10-1/4"	12'-1-7/8"	17'-8"
11'-0"	12'-6-3/4"	12'-7-7/8"	18'-4-1/2"
11'-6"	13'-3-1/4"	13'-1-7/8"	19'-1"
12'-0"	13'-11-3/4"	13'-7-7/8"	19'-9-1/2"
12'-6"	14'-8-1/4"	14'-1-7/8"	20'-6"

Min. Drop is 2'-1-3/8" where S = 0
 L = 3'-9-1/4"
 C = 5'-9-3/4"

3'0" RADIUS X 45 DEGREES

DROP	S	L	C
3'-0"	0'-5-1/8"	5'-5-7/8"	7'-9-5/8"
3'-6"	1'-1-5/8"	5'-11-7/8"	8'-6-1/8"
4'-0"	1'-10"	6'-5-7/8"	9'-2-5/8"
4'-6"	2'-6-1/2"	6'-11-7/8"	9'-11-1/8"
5'-0"	3'-3"	7'-5-7/8"	10'-7-5/8"
5'-6"	3'-11-1/2"	7'-11-7/8"	11'-4-1/8"
6'-0"	4'-8"	8'-5-7/8"	12'-0-1/2"
6'-6"	5'-4-1/2"	8'-11-7/8"	12'-9"
7'-0"	6'-1"	9'-5-7/8"	13'-5-1/2"
7'-6"	6'-9-1/2"	9'-11-7/8"	14'-2"
8'-0"	7'-6"	10'-5-7/8"	14'-10-1/2"
8'-6"	8'-2-3/8"	10'-11-7/8"	15'-7"
9'-0"	8'-10-7/8"	11'-5-7/8"	16'-3-1/2"
9'-6"	9'-7-3/8"	11'-11-7/8"	17'-0"
10'-0"	10'-3-7/8"	12'-5-7/8"	17'-8-3/8"
10'-6"	11'-0-3/8"	12'-11-7/8"	18'-4-7/8"
11'-0"	11'-8-7/8"	13'-5-7/8"	19'-1-3/8"
11'-6"	12'-5-3/8"	13'-11-7/8"	19'-9-7/8"
12'-0"	13'-1-7/8"	14'-5-7/8"	20'-6-3/8"
12'-6"	13'-10-1/4"	14'-11-7/8"	21'-2-7/8"

Min. Drop is 2'-8-3/8" where S = 0
 L = 5'-2-1/4"
 C = 7'-4-1/2"

NOTE: All horizontal and vertical turns are heat treated on the contact surface to RC35-40.

VERTICAL BENDS
60° CURVE

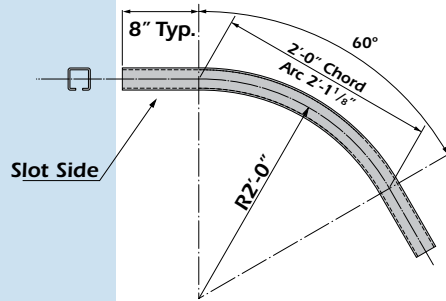
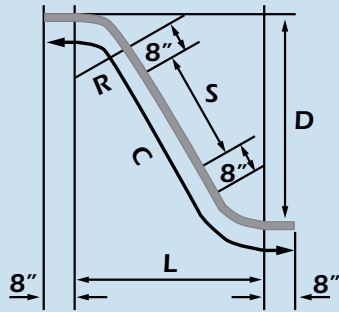

AC 8038 UPPER VERTICAL CURVE 2'-0" RAD. X 60°

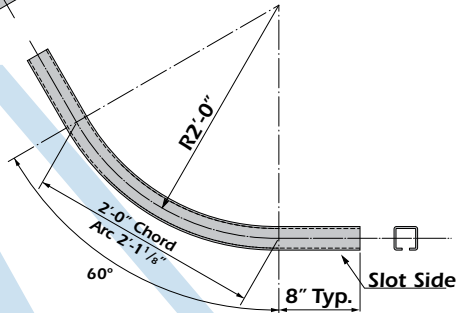

AC 8039 LOWER VERTICAL CURVE 2'-0" RAD. X 60°

2'0" RADIUS X 60 DEGREES

DROP	S	L	C
3'-6"	0'-4-3/4"	4'-4"	7'-3"
4'-0"	0'-11-3/4"	4'-7-3/8"	7'-10"
4'-6"	1'-6-5/8"	4'-10-7/8"	8'-4-7/8"
5'-0"	2'-1-5/8"	5'-2-3/8"	8'-11-7/8"
5'-6"	2'-8-1/2"	5'-5-7/8"	9'-6-3/4"
6'-0"	3'-3-3/8"	5'-9-1/4"	10'-1-3/4"
6'-6"	3'-10-3/8"	6'-0-3/4"	10'-8-5/8"
7'-0"	4'-5-1/4"	6'-4-1/4"	11'-3-1/2"
7'-6"	5'-0-1/4"	6'-7-5/8"	11'-10-1/2"
8'-0"	5'-7-1/8"	6'-11-1/8"	12'-5-3/8"
8'-6"	6'-2-1/8"	7'-2-5/8"	13'-0-3/8"
9'-0"	6'-9"	7'-6-1/8"	13'-7-1/4"
9'-6"	7'-3-7/8"	7'-9-1/2"	14'-2-1/4"
10'-0"	7'-10-7/8"	8'-1"	14'-9-1/8"
10'-6"	8'-5-3/4"	8'-4-1/2"	15'-4"
11'-0"	9'-0-3/4"	8'-7-7/8"	15'-11"
11'-6"	9'-7-5/8"	8'-11-3/8"	16'-5-7/8"
12'-0"	10'-2-5/8"	9'-2-7/8"	17'-0-7/8"
12'-6"	10'-9-1/2"	9'-6-3/8"	17'-7-3/4"

Min. Drop is 3'-1-7/8" where S = 0
L = 4'-1-5/8"
C = 6'-10-1/4"

3'0" RADIUS X 60 DEGREES

DROP	S	L	C
4'-6"	0'-4-3/4"	6'-0-3/4"	9'-4-1/8"
5'-0"	0'-11-3/4"	6'-4-1/4"	9'-11-1/8"
5'-6"	1'-6-5/8"	6'-7-5/8"	10'-6"
6'-0"	2'-1-5/8"	6'-11-1/8"	11'-1"
6'-6"	2'-8-1/2"	7'-2-5/8"	11'-7-7/8"
7'-0"	3'-3-3/8"	7'-6-1/8"	12'-2-7/8"
7'-6"	3'-10-3/8"	7'-9-1/2"	12'-9-3/4"
8'-0"	4'-5-1/4"	8'-1"	13'-4-5/8"
8'-6"	5'-0-1/4"	8'-4-1/2"	13'-11-5/8"
9'-0"	5'-7-1/8"	8'-7-7/8"	14'-6-1/2"
9'-6"	6'-2-1/8"	8'-11-3/8"	15'-1-1/2"
10'-0"	6'-9"	9'-2-7/8"	15'-8-3/8"
10'-6"	7'-3-7/8"	9'-6-3/8"	16'-3-3/8"
11'-0"	7'-10-7/8"	9'-9-3/4"	16'-10-1/4"
11'-6"	8'-5-3/4"	10'-1-1/4"	17'-5-1/8"
12'-0"	9'-0-3/4"	10'-4-3/4"	18'-0-1/8"
12'-6"	9'-7-5/8"	10'-8-1/8"	18'-7"

Min. Drop is 4'-1-7/8" where S = 0
L = 5'-10-3/8"
C = 8'-11-3/8"

NOTE: All horizontal and vertical turns are heat treated on the contact surface to RC35-40.

UPPER VERTICAL CURVES

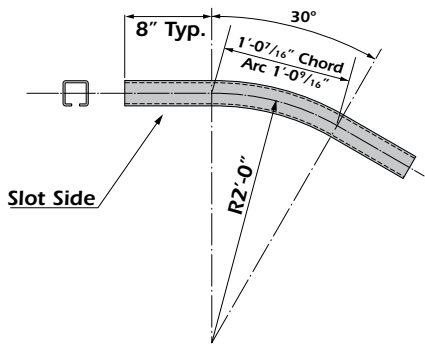

AC 8026 UPPER VERTICAL CURVE 2'-0" RAD. X 30°

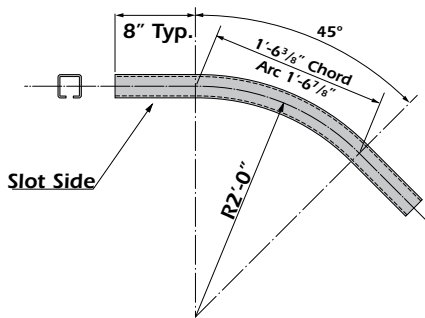

AC 8025 UPPER VERTICAL CURVE 2'-0" RAD. X 45°

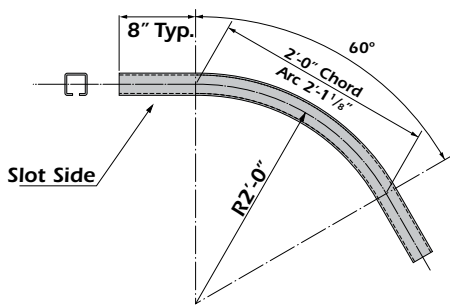

AC 8038 UPPER VERTICAL CURVE 2'-0" RAD. X 60°

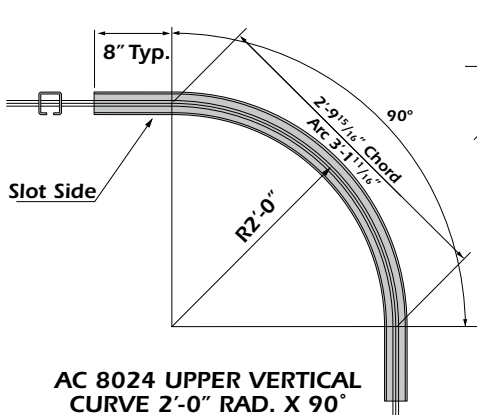

AC 8024 UPPER VERTICAL CURVE 2'-0" RAD. X 90°

LOWER VERTICAL CURVES

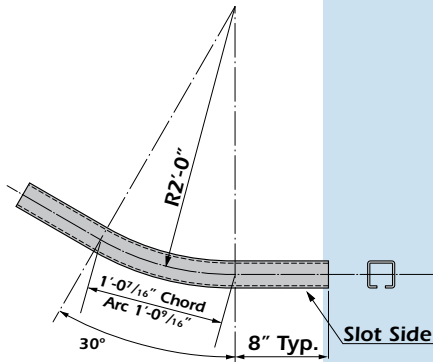

AC 8029 LOWER VERTICAL CURVE 2'-0" RAD. X 30°

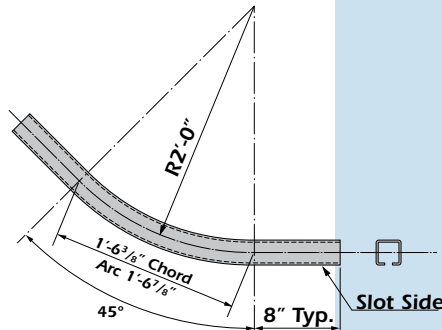

AC 8028 LOWER VERTICAL CURVE 2'-0" RAD. X 45°

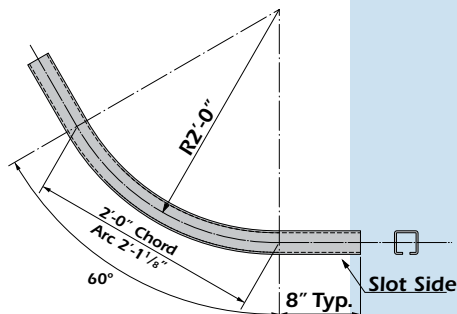

AC 8039 LOWER VERTICAL CURVE 2'-0" RAD. X 60°

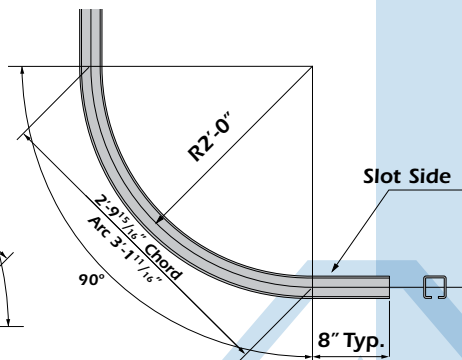

AC 8027 LOWER VERTICAL CURVE 2'-0" RAD. X 90°

HORIZONTAL TURNS

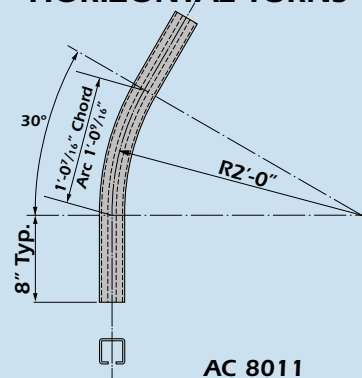

AC 8011 HORIZONTAL TURN 2'-0" RAD. X 30°

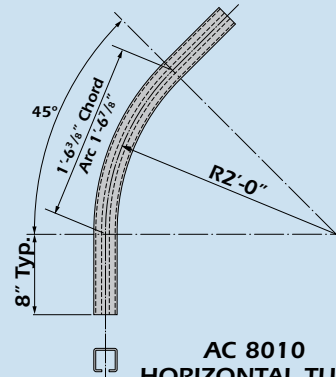

AC 8010 HORIZONTAL TURN 2'-0" RAD. X 45°

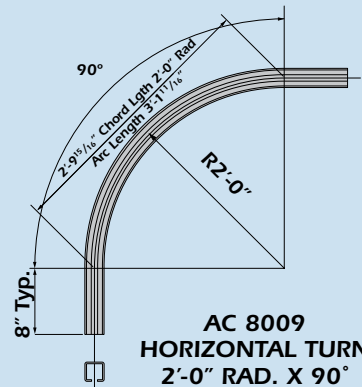

AC 8009 HORIZONTAL TURN 2'-0" RAD. X 90°

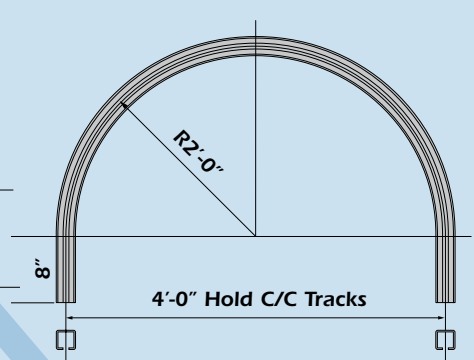

AC 8008 HORIZONTAL TURN 2'-0" RAD. X 180°

The upper and lower vertical curves, as well as horizontal turns, illustrated above are carried in stock. Special radius or degree curves can be fabricated to-order.

NOTE: All horizontal and vertical turns are heat treated on the contact surface to RC35-40.



ALLIED

8000 Series Enclosed Track Standard Components

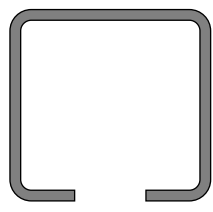

TRACK

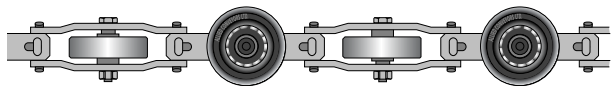

CHAIN



VERTICAL BENDS

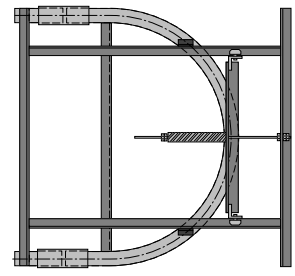

TAKE-UPS

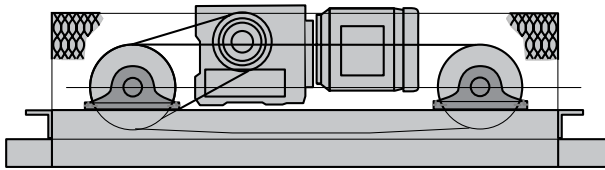

DRIVES

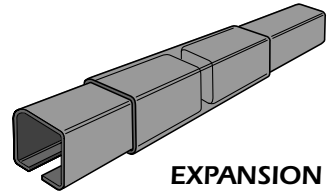

EXPANSION JOINTS

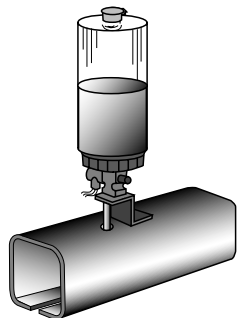

LUBRICATORS

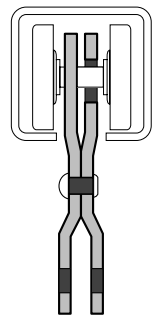

"H" ATTACHMENT

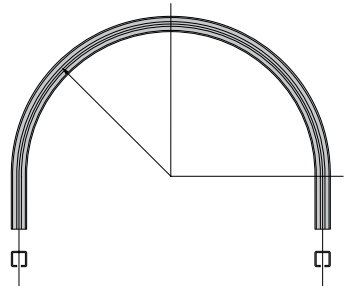

HORIZONTAL TURNS

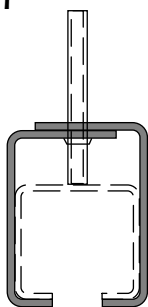

INSTALLATION CLAMPS

- AC-8001** Straight track (20'0" long)
- AC-8368** Chain 8-1/8" Pitch
- AC-8369** Master Connecting Link
- AC-8367** Pivoting "H" Attachment
- AC-8368** Rigid "H" Attachment
- AC-8007** Load Bar
- AC-8008** 2'0" R x 180° Horizontal Turn
- AC-8009** 2'0" R x 90° Horizontal Turn
- AC-8010** 2'0" R x 45° Horizontal Turn
- AC-8011** 2'0" R x 30° Horizontal Turn
- AC-8012** 2'0" R x 4'0" Spread Spring Type Take-up (8" Travel)
- AC-8013** 2'0" R x Variable Spread Spring Type Take-up (8" Travel)
- AC-8014** 1'0" R x 2'0" Spread Vertical Manual Screw Type Take-up
- AC-8015** Diameter Traction Wheel
- AC-8016** Diameter x 180° Traction Wheel Platform
- AC-8017** Traction Wheel Stub Shaft Conventional Type
- AC-8018** Traction Wheel Stub Shaft Oven Type
- AC-8019** Traction Wheel Hub Conventional Type
- AC-8020** Traction Wheel Hub Oven Type
- AC-8021** Cat Drive Assembly Variable Speed
- AC-8022** Cat Drive Assembly Constant Speed
- * **AC-8097** 1'0" R x 180° Lower Vertical Bend
- AC-8024** 2'0" R x 90° Upper Vertical Curve
- AC-8025** 2'0" R x 45° Upper Vertical Curve
- AC-8026** 2'0" R x 30° Upper Vertical Curve
- AC-8027** 2'0" R x 90° Lower Vertical Curve
- AC-8028** 2'0" R x 45° Lower Vertical Curve
- AC-8029** 2'0" R x 30° Lower Vertical Curve
- AC-8030** Expansion Joint Assembly
- AC-8031** Chain Installation Gate
- AC-8032** Chain Inspection Gate
- AC-8033** Anti-backup Stop (Inclines)
- AC-8034** Anti-runway Stop (Declines) Complete With Limit Switch
- AC-8035** Automatic Shut-off Brush Type Chain Lubricator (1 Quart)
- AC-8036** Manual Shut-off Brush Type Chain Lubricator (1 Quart)
- AC-8037** Automatic 5 Point Chain and Wheel Lubricator (1 Gallon)
- AC-8038** 2'0" R x 60° Upper Vertical Curve
- AC-8039** 2'0" R x 60° Lower Vertical Curve
- AC-8040** 4 Wheel Hand Pushed Trolley
- AC-8041** Extended Rigid "H" Attachment

Complete range of bolted and welded installation clamps, headers and hangers are available.

*For gravity flow loops only



Allied Conveyor Systems, Inc.
PO Box 1054
Statham, GA 30666
USA

866.959.2993

www.AlliedConveyorSystems.com

This catalog illustrates the various Allied 8000 Series Components available for use in making up a conveyor system. Allied Conveyor Systems, Inc. disclaims all responsibility for any equipment or system, malfunction, violation of law, property damage, personal injury or any damages resulting from the equipment selection, design, installation or operation carried out by a contractor.