

Uniclass P341	EPIC E351
CI/SfB	Ys4

March 2001

Mastic Asphalt Handbook by *Permanite*

PERMANITE
ASPHALT

Introduction

Mastic Asphalt

Mastic asphalt has a long and successful history covering a wide range of uses as a waterproofing medium for roofs, basements and foundations, and as a surfacing material for floors and paving.

The product comprises suitably graded aggregates bound together with an asphaltic cement (primarily refined bitumens) to produce a dense voidless material. It cannot be compacted and is spread rather than rolled.

Permanite Asphalt

Permanite Asphalt, a subsidiary of Ruberoid PLC is the major U.K. manufacturer of mastic asphalts, operating from two plants located at Matlock and Salford.

Each plant operates under a Quality Assurance Scheme to BS EN ISO 9002, has strict quality control procedures and a strong laboratory back up providing testing facilities for both raw materials and manufactured asphalts to ensure quality and uniformity. Although Kitemarked and covered by BSI Certification schemes, the aggregates and asphaltic cement are accurately blended to within much narrower requirements than those set out in The British Standards.

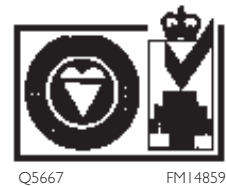

Technical Advisory Service

The laboratory back-up, coupled with many years of direct experience in the industry, enables Permanite Asphalt to provide a comprehensive Technical Advisory Service for the designer, specifier and contractor.

The Mastic Asphalt Handbook is only one element of our service, and if you require further technical advice please contact our Technical Services Department.

Permanite Limited,

Technical Services,

Cawdor Quarry, Matlock, Derbyshire DE4 2JH

Tel: (01629) 582213

Fax: (01629)583375

Section 1

Roofing

Section 2

Tanking

Section 3

Flooring

Section 4

Paving

Contents

ROOF DECKS	PAGE 1
FALLS TO CLEAR WATER	PAGE 1
SCREEDS	PAGE 1
CONDENSATION AND VAPOUR BARRIERS	PAGE 2
THERMAL INSULATION	PAGE 2
SEPARATING LAYER	PAGE 3
TYPES OF MASTIC ASPHALT	PAGE 4
APPLICATION OF ASPHALT	PAGE 4
KEYING TO SURFACES	PAGE 4
DETAIL FINISHES	PAGE 5
SURFACE PROTECTION	PAGE 7
TYPICAL SPECIFICATIONS	PAGE 8
CONCRETE DECKS	PAGE 8
TIMBER DECKS	PAGE 11
WOODWOOL DECKS	PAGE 11
METAL DECKING DECKS	PAGE 14
PROTECTED MEMBRANE ROOF	PAGE 16
SPECIAL APPLICATIONS	PAGE 17
BALCONIES, TERRACES AND ACCESS DECKS	PAGE 17
ROOF GARDENS	PAGE 19
ROOF-TOP CAR PARKS	PAGE 19
REPAIRS AND MAINTENANCE	PAGE 19



Roofing

Introduction

Mastic asphalt can be applied to form a continuous waterproof covering over flat, sloped or curved surfaces and can be worked round pipes, roof lights and other projections.

It can be laid on most types of rigid sub-structure such as concrete, pre-cast concrete deck units, timber boarding, metal decking and other proprietary decking units. Thermal insulation materials can easily be laid as part of a mastic asphalt specification to give any required U-value. Treatments applied to asphalt can provide a surface suitable for traffic, increase solar reflectivity and provide a decorative finish.

This handbook should be used in conjunction with British Standard Codes of Practice BS 8218, BS 6229 and BS 8000: Part 4.

Roofing

ROOF DECKS

Structural decking to comply with the recommendations of B.S. 6229: 1982 – (Flat roofs with continuously supported coverings) and be laid in accordance with relevant Codes of Practice.

All substrates to receive mastic asphalt roofing must be true, plane and, even free from ridges, hollows and indentations.

IN SITU CONCRETE

Concrete laid in situ to receive asphalt should have a surface free from ridges and indentations. To achieve this and to provide adequate falls it is usually necessary to apply a sand and cement screed. Construction water should be drained by forming temporary drainage holes through the slab – Reference BS 6229.

PRECAST CONCRETE

A variety of precast deck units are available in dense or lightweight concrete and these should be used and fixed in accordance with the manufacturer's instructions.

Precast concrete units usually require a screeded finish to take out any deck irregularity and provide drainage falls unless specifically excluded by the manufacturer.

Construction water should be drained by leaving the deck joints open or by forming temporary drainage holes through the deck – Reference BS 6229.

TIMBER

Where the sub-structure consists of timber board, plywood, woodwool slab or decking units liable to slight lateral movement a free standing splayed timber kerb must be fixed to the sub-structure 12mm clear of walls and upstands (see detail finishes page 5).

Timber board

Timber boards to receive asphalt should

be tongued and grooved, well seasoned, at least 19mm nominal thickness, closely clamped together and well nailed.

Plywood

Plywood roof decks should be designed to minimise the effects of warping, shrinkage or movement of the boards. Timber surrounds are necessary at eaves and verges. Decks of this type should be kept dry. They should not be fixed in position unless they can be covered the same day. For structural deck applications, plywood should comply with the relevant requirements of BS 6566, be WBP bonded in accordance with BS 6566 Part 8, and be at least 19mm thick.

Woodwool slabs

These must be of a roofing grade, complying with BS 1105 (1981) Type SB fixed according to the manufacturer's instructions to timber joists or steel purlins with all joints taped. Pre-felted or un-screeded types would only be used in conjunction with board insulation.

METAL DECKING

Steel or aluminium decking with a vapour control layer, insulation boards and asphalt can be laid to form a complete roof structure. When asphalt is used in conjunction with metal decking, the deflection should not be more than 1/325. The decking units are fixed in accordance with the manufacturer's instructions. The vapour control layer is bonded to the top surface of the metal decking, followed by the insulation board which is bonded in hot bitumen. Timber facings to free standing metal upstands are required for the application of the asphalt finishes. For high humidity situations aluminium decks are recommended, but if steel decks are used a protective coating to both sides of the deck should be specified.

FALLS TO CLEAR WATER

Where required, falls of not less than 1 in 80 must be provided for water to clear the roof. To allow for normal construction tolerances and achieve a finished fall of 1:80, a design fall of at least 1:50 (2.0%) is required, if freedom from ponding on the finished roof is to be achieved.

SCREEDS

SAND AND CEMENT

Some types of sub-structure require a sand and cement screed to receive the asphalt. This should consist of 1 part cement to 4 parts clean coarse sand by volume and be finished with a wooden float to a smooth surface. It should be laid in bays not exceeding 9m² in area, to reduce the incidence of cracking due to drying shrinkage. The screed should be adequately cured before application of the asphalt.

PROPRIETARY SCREEDS

Several proprietary screeds are available and all must be laid strictly in accordance with the manufacturers' instructions.

Cementitious screeds are recommended in order to provide a stable base to receive mastic asphalt.

CONDENSATION AND VAPOUR CONTROL LAYERS

Water vapour is always present in varying amounts in the atmosphere, and when it comes into contact with a cold surface the vapour may condense into liquid.

Condensation is liable to occur on the internal surfaces of the walls and roof of a building if the temperature and humidity of the air inside the building is appreciably higher than the outside atmosphere, particularly if the walls and roof have low thermal insulation values.

In practice such condensation is frequently more severe under the roof than on the walls, partly because roofs often cool rapidly at night by radiation to a clear sky and partly because, in the past, roofs have usually had lower thermal insulation values than walls.

When designing a roof the problem of condensation must always be borne in mind. In the case of a roof incorporating asphalt a layer of dry thermal insulation material may be introduced under the asphalt. This layer must have sufficient insulation value for its underside to remain

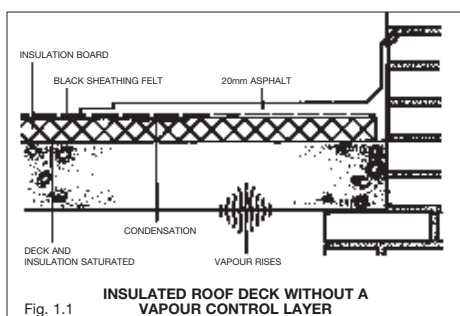

above the temperature at which condensation can start, even on the coldest nights. The provision of insulating material alone, however, may not be sufficient to prevent condensation. If the material is permeable to water vapour, the vapour will pass upwards through it and condense on the underside of the waterproof membrane (Fig. 1.1).

The droplets of water formed will then soak back into the insulating layer, eventually saturating it and lowering its

insulation value, and possibly causing unsightly staining on the ceiling beneath.

To prevent this happening a vapour check or full vapour barrier should be provided on the underside of the insulating layer.

A vapour barrier can be formed of two layers of roofing felt with side and end laps fully sealed. A single 13mm thick coat of asphalt on an underlay of glass fibre tissue can also be used as a vapour barrier (fig. 1.2). If the vapour check/barrier is used as a temporary waterproofing it will be necessary to repair any damage caused by subsequent operations prior to the installation of insulation and waterproofing.

The droplets of water formed will then soak back into the insulating layer, eventually saturating it and lowering its insulation value, and possibly causing unsightly staining on the ceiling beneath.

To prevent this happening a vapour check or full vapour barrier should be provided on the underside of the insulating layer. A vapour barrier can be formed of two layers of roofing felt with side and end laps fully sealed. A single 13mm thick coat of asphalt on an underlay of glass fibre tissue can also be used as a vapour barrier (fig. 1.2). If the vapour check/barrier is used as a temporary waterproofing it will be necessary to repair any damage caused by subsequent

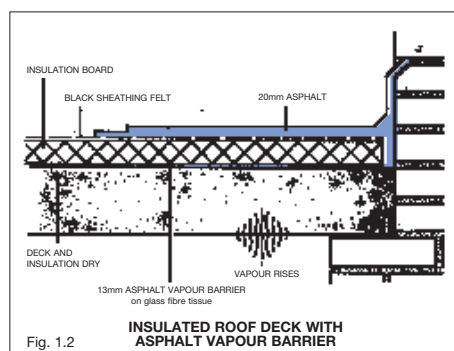

operations prior to the installation of insulation and waterproofing.

It should be noted that the use of a separate vapour control layer is not required in the 'protected membrane

system' described on page 16.

THERMAL INSULATION

The statutory requirements for the thermal

Buildings other than dwellings		
Residential	Other	Dwellings
0.35 W/m ² k	0.45 W/m ² k	0.35, 0.2 W/m ² k*

insulation of roofs are set out in approved document L – Conservation of Fuel and Power to the Building Regulations 1991. This document requires roofs to have the following maximum U values.

The statutory requirements for the thermal insulation of roofs are set out in approved document L – Conservation of Fuel and Power to the Building Regulations 1991. This document requires roofs to have the following maximum U values.

*Dependant on Building SAP rating.

These requirements are usually achieved by the inclusion of insulation boards beneath the waterproofing in a warm room system or above the waterproofing in a protected membrane system.

There are several types of insulation suitable for use in mastic asphalt roofing specifications. The following types are the most frequently used. All must be laid strictly in accordance with the manufacturer's instructions.

CORK

Cork is resistant to moisture and decay and provides a substrate of good laminar strength making it an ideal base to receive mastic asphalt.

Cork/polyurethane foam composite boards provide good insulation within acceptable thickness limits.

CELLULAR GLASS

This type of board is non combustible, impermeable to water and can normally be laid without a vapour control layer. The products high compressive strength makes it an ideal base for asphalt, particularly in situations where pedestrian traffic is anticipated.

Roofing

When asphalt is applied over cellular glass insulation, two layers of non-bituminous building paper are required between the slabs and the sheathing felt to prevent adhesion.

PERLITE

Perlite offers a high level of dimensional stability with good fire resistance. Perlite/Polyurethane composite boards provide a stable base for mastic asphalt together with good insulating properties.

POLYISOCYANURATE FOAMS

Suitable formulations of polyisocyanurate boards are available for use under mastic asphalt. As mastic asphalt retains a high temperature for long periods after application the board used must be designed to maintain dimensional stability during the application and cooling of the asphalt. It provides a substrate that is an ideal base for mastic asphalt.

EXTRUDED POLYSTYRENE

Extruded polystyrene is used in the Protected Membrane Roof system. Full details regarding the use of this type of board together with thermal insulation values are to be found under the Protected Membrane Roof system on page 16.

TABLE OF THERMAL INSULATION VALUES

Insulation	U-Value (W/m ² K)		
	0.45	0.35	0.2
Polyisocyanurate foam	50mm	65mm	115mm
Cork/polyurethane composite	60mm	70mm	125mm
Cellular Glass	80mm	90mm	180mm
Perlite/Polyurethane composite	60mm	70mm	120mm

Insulation	U-Value (W/m ² K)		
	0.45	0.35	0.2
Polyisocyanurate foam	35mm	50mm	105mm
Cork/polyurethane composite	50mm	60mm	110mm
Cellular Glass	70mm	90mm	170mm
Perlite/Polyurethane composite	50mm	70mm	120mm

Insulation	U-Value (W/m ² K)		
	0.45	0.35	0.2
Polyisocyanurate foam	40mm	55mm	105mm
Cork/polyurethane composite	50mm	70mm	115mm
Cellular Glass	60mm	90mm	170m
Perlite/Polyurethane composite	50mm	60mm	110mm

Insulation	U-Value (W/m ² K)		
	0.45	0.35	0.2
Polyisocyanurate foam	50mm	65mm	120mm
Cork/polyurethane composite	60mm	80mm	125mm
Cellular Glass	80mm	100mm	190mm
Perlite/Polyurethane composite	60mm	80mm	120mm

DECK: 150mm IN SITU CAST SLAB AND SCREED

DECK: 100mm PRECAST LIGHTWEIGHT

CONCRETE UNITS

DECK: 19mm TONGUED AND GROOVED BOARDS

DECK: 50mm WOODWOOL SLAB

DECK: STEEL OR ALUMINIUM DECKING

Insulation	U-Value (W/m ² K)		
	0.45	0.35	0.2
Polyisocyanurate foam	50mm	65mm	115mm
Cork/polyurethane composite	60mm	70mm	125mm
Cellular Glass	70mm	90mm	180mm
Perlite/Polyurethane composite	50mm	70mm	120mm

SEPARATING LAYER

The purpose of the separating layer is to isolate the asphalt from joint movement in the substrate but still provide a significant friction to help restrain the asphalt against contraction in cold weather. It must also allow a free lateral passage for hot air and moisture vapour during the application of the hot asphalt and act as a long term vapour pressure release layer.

Separation is normally provided by black sheathing felt which is laid entirely loose with lap joints of 50mm. Sheathing felt has ideal characteristics as a separating layer for normal roof specification. However, since it allows a small amount of compression under vehicular traffic, a glass fibre tissue separating layer is preferred to provide a firm support under combined roofing/paving specifications. This is again laid loose with 50mm laps.

Mastic Asphalt for Roofing (limestone aggregate) BS 6925: 1988 Type R 988.

Although Kitemarked and covered by BSI Certification the following grades are manufactured to within much narrower requirements than those set out in the British Standard specification.

Roofstar B Product code 4101 BS 6925: 1988 Type R 988/1/B	The basic roofing grade with an asphaltic cement composition of 100% bitumen, provides proven performance at an economic price.
Roofstar T Product code 4012 BS 6925: 1988 Type R 988/1/T25	The addition of 25% Trinidad Lake asphalt to the asphaltic cement composition gives improved laying qualities, and greater thermal stability.

SPECIAL GRADES

Permanite Asphalt Ltd has specialised products in its Roofstar range including acid resisting material, coloured and export grades and materials designed for pedestrian walkways.

Permaphalt is a specially formulated polymer modified mastic asphalt designed to provide even higher performance characteristics than standard grades of asphalt roofing. Permaphalt provides increased high temperature stability coupled with low temperature flexibility in all roofing situations, particularly over insulated substrates. For further details please contact our Technical Services Department.

APPLICATION OF ASPHALT

The application of roofing asphalt should be in accordance with BS 8218 and BS 8000: Part 4.

FLAT ROOFS UP TO 10°

Roofing asphalt is normally laid in two coats, breaking joint, to a total thickness of 20mm on an underlay of black sheathing felt laid loose with 50mm lapped joints.

Where thermal insulation is laid beneath the weather-proofing it is recommended that the roof pitch does not exceed 5° and the asphalt is given a reflective surface which will minimise heat build-up through solar radiation (see page 7 Surface Protection).

SLOPES OVER 10° AND VERTICAL SURFACES (EXCLUDING SKIRTINGS)

Roofing Asphalt laid on concrete or screeded sub-structures of 10°–30° slope is applied in two coats to a total thickness of 20mm direct to the concrete.

For vertical work over 300mm and slopes over 30° the asphalt is applied in three coats, the first coat being applied very thinly with a steel trowel or small wooden float. A further two coats are then applied, breaking joint, to give a total thickness of 20mm. For these applications the concrete must be left with a roughened surface to form a key for the asphalt.

In the case of sloping timber surfaces over 10° a layer of black sheathing felt is first nailed to the timber. Bitumen primed expanded metal lathing is then fixed at 150mm centres with galvanised clout nails to form a key for the asphalt which is applied in three coats to a total thickness of 20mm.

SAND RUBBING

In all cases where the asphalt is laid on flat or slightly sloping roofs, clean sharp sand should be rubbed evenly into the surface on the asphalt while it is still hot. This rubbing breaks up the skin of bitumen brought to the surface by the wooden float at the time of application. Gradual crazing of the surface due to the

action of the sun is minimised by sand rubbing in this way.

KEYING TO SURFACES

CONCRETE

Apply a light brush coat of High Bond Primer and allow to dry thoroughly before applying asphalt.

Where vertical or sloping concrete is very smooth (e.g. where steel shuttering has been used), the surface laitence should be removed by wire brush or suitable mechanical means to provide a satisfactory key for the asphalt. Where excessive blowing is experienced the fixing of bitumen coated expanded metal lathing over black sheathing felt may be required.

Note

Damage to asphalt and loss of key will be caused by excessive use of mould oil.

Asphalt cannot be applied directly to lightweight concrete or block work which should be rendered with a suitable sand cement facing or have bitumen coated expanded metal lathing on sheathing felt fixed at maximum 150mm centres.

BRICKWORK

Joints in brickwork should be flush pointed. The surface must be cleaned and high bond primer applied to avoid blistering or loss of bond.

TIMBER

The key to vertical or sloping timber surfaces is obtained by fixing expanded metal lathing over black sheathing felt fixed by nailing with extra large head galvanised felt nails to BS1202 or with galvanised staples at maximum 150mm centres.

The expanded metal lathing and black sheathing felt are supplied laid and fixed by the asphalter.

Roofing

DETAIL FINISHES

SKIRTINGS AND FLASHINGS

In the case of concrete and similar sub-structures a two-coat asphalt skirting (nominal thickness 13mm) is necessary at all upstands to a minimum height of 150mm; a two coat angle fillet being formed at the junction of the vertical and the flat. The top of the skirting is splayed and turned into a chase 25mm deep and 25mm wide unless the asphalt continues horizontally (Fig. 1.3).

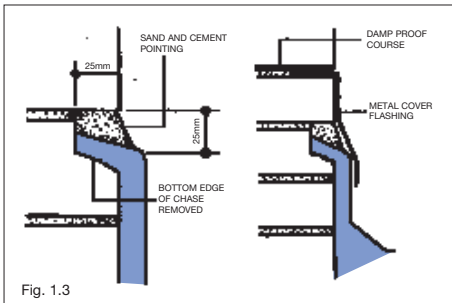

Where the substructure consists of timber board, plywood, woodwool slab or decking units which are liable to slight lateral movement require a free-standing splayed timber kerb fixed to the sub-structure 12mm clear of walls and upstands. The asphalt is then applied in three coats to a total thickness of 20mm on to bitumen coated expanded metal lathing fixed over black sheathing felt. The skirting is cover-flashed and protected by an application of solar reflective paint. (Fig. 1.4).

Where insulation is used beneath the asphalt a minimum 25mm wide support leg to the skirtings is essential. (Fig. 1.4).

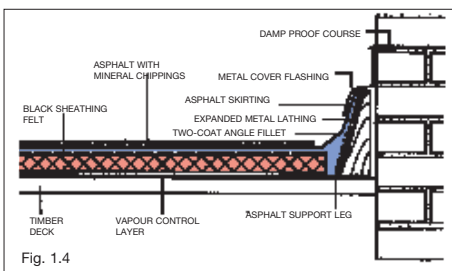

VERGES

Perimeter kerbs may be completed with a g.r.p. edge trim fixed at 300mm max. centres (Fig. 1.5). Alternatively, an asphalt apron with an undercut drip may be formed (Fig. 1.6 and 1.7).

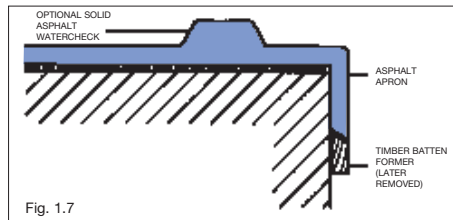
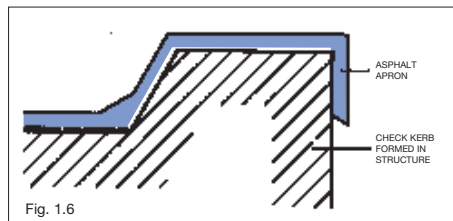
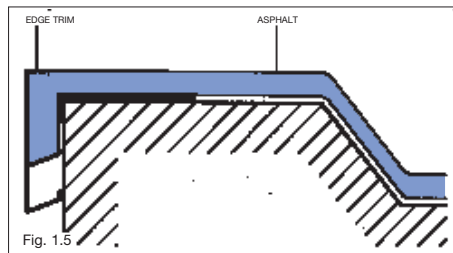

EAVES GUTTERS

Where the roof fall is into an eaves gutter the asphalt can be finished over a lead flashing set into a rebate in the sub-structure. The lead must be welted at the back and the depth of the rebate must allow for a full thickness of asphalt over the welt. (Fig. 1.8).

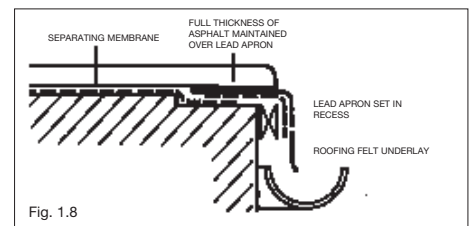

Alternatively, an asphalt apron or purposely made GRP Edge Trim can be used.

OUTLETS THROUGH PARAPET WALLS

At outlets through parapet walls the asphalt is taken through the wall on to a pre-formed lead chute.

GULLIES AND OUTLETS

Several types of gullies can be used in conjunction with asphalt but cast iron or aluminium silicon alloy outlets with a bellmouth and internal clamp ring are particularly recommended (Fig. 1.9 and Fig. 1.10).

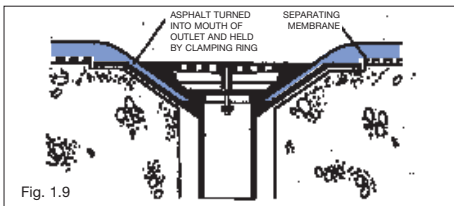

Fig. 1.9

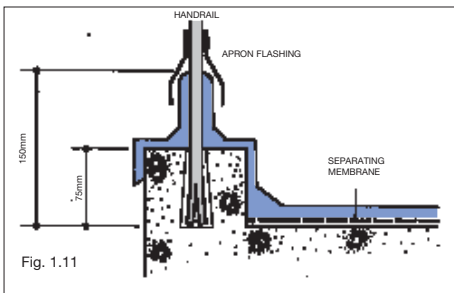

Fig. 1.11

PROJECTIONS THROUGH ROOFS

Projections fixed in or passing through the roof, such as handrail standards, pipes, metal chimney and ventilation ducts, should incorporate a metal hood. The asphalt is dressed 150mm up the projection and tucked in beneath the metal hood. (Fig. 1.11)

Certain manufacturers of vent pipes make special fittings available to provide a protection and weathering to the top edge of the asphalt. These are an excellent arrangement and are to be recommended.

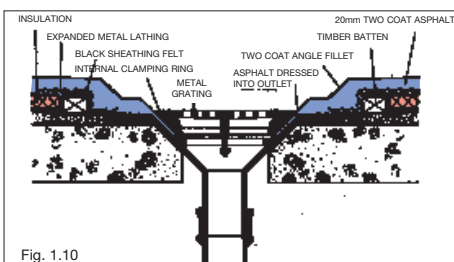

Fig. 1.10

GUTTERS

These can be lined in asphalt to follow any shape or contour in the sub-structure. Where a gutter is formed between a parapet wall and a tiled or pitched roof, the asphalt is carried up the slope and over the tilting fillet. (Fig. 1.12)

It is generally preferable to avoid the use of integral gutters on flat roofs, using, instead, falls and cross falls to direct the flow of water.

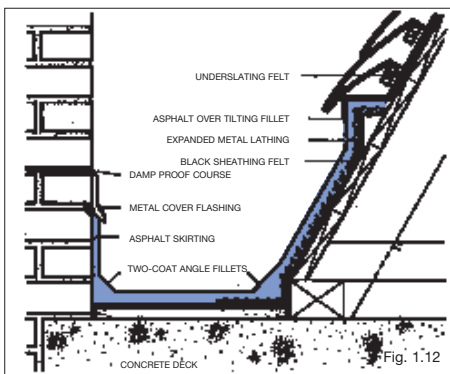

Fig. 1.12

ROOFLIGHTS AND VENTILATORS

Rooflights are commonly mounted on kerbs 150mm above the roof finish. The asphalt roofing is then taken up the side and over the top of the kerb before the roof light is placed in position.

Metal cover flashings are recommended for such details and these must also be applied before the roof light is fixed.

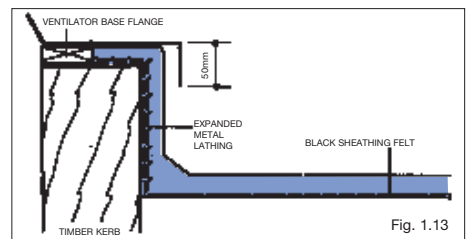

Fig. 1.13

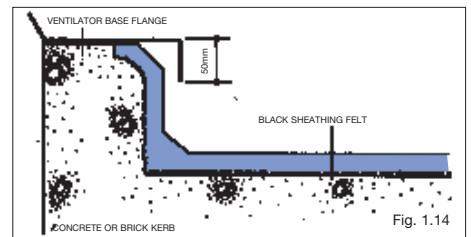

Fig. 1.14

Roofing

Proprietary metal rooflight kerbs should have a grooved surface to receive the mastic asphalt or alternatively expanded metal lathing may be spot welded to the kerb. If spot welding is not practical, the expanded metal lathing should be fixed to a timber facing over black sheathing felt. (Fig. 1.24).

Plastic curbs are also available but advice on their suitability and use must be obtained from the manufacturers. It is usually recommended that a timber facing is fixed to the kerb and treated as above.

MOVEMENT JOINTS

Twin kerb movement joints are recommended with a metal cap flashing fixed to one kerb only, or a capping system held by cleats or spring clips (Fig. 1.15). In either case suitable fixings should be provided to avoid penetrating the asphalt.

All ends should be boxed as necessary to complete the waterproofing but still allow movement. Special detail design will be required to avoid the risk of increased maintenance and repair.

The design of the structure should avoid flush surface movement joints if at all possible. However, proprietary systems are available for this application and specialist advice is necessary.

SURFACE PROTECTION

A sand rubbed surface is necessary to reduce the incidence of surface crazing, and when asphalt is applied direct to the structural deck with no insulation, further solar protection may be omitted.

Where asphalt is laid onto efficient insulation in a warm roof construction a protective surface should be applied to all flat areas using stone chippings, promenade tiles or a suitable reflective coating.

STONE CHIPPINGS

A single layer of 10–15mm dust free stone chippings is normally used in order to provide solar protection and will act as a permanent protection for the full life of the asphalt.

When the chippings are well bonded to the asphalt removal can be difficult and therefore it is better to provide a minimum bond to ensure that they remain in place. This can be achieved by using a cold applied bitumen solution.

REFLECTIVE COATINGS

Asphalt skirtings, and all vertical areas of asphalt roofing require protection by the use of a suitable reflective paint finish, but it must be remembered that periodic repainting will be required.

PROMENADE SURFACING

Where pedestrian traffic is anticipated a surfacing of tiles or paving slabs may be used. All tiled or paved areas must be efficiently drained as small amounts of standing water or dampness will lead to mould growth, or the formation of ice in cold weather.

Falls of at least 1 in 80 are required as a minimum but a design fall of 1 in 50 is recommended.

Porous concrete and GRC promenade tiles provide a lightweight surfacing. They must be applied strictly in accordance with the manufacturer's instructions.

Concrete pavings are often used as a promenade surface. They may be supported on felt shims or bedded in sand and cement. In the latter instance it is first necessary to overlay the mastic asphalt with a building paper to allow differential movement between the waterproofing and surfacing.

An allowance for expansion is necessary and it will usually be sufficient to set the tiles or slabs back 75mm from the vertical at the roof perimeter and around interruptions with intermediate joints at 3m centres.

Proprietary plastic corner supports are also used to support concrete slabs and, by separating the promenade surfacing from the asphalt, allow rapid dispersal of surface water, and easy access for inspection and repair. These can, however, cause severe indentation in a warm roof specification and their use should therefore be restricted to the protected membrane system or uninsulated decks.

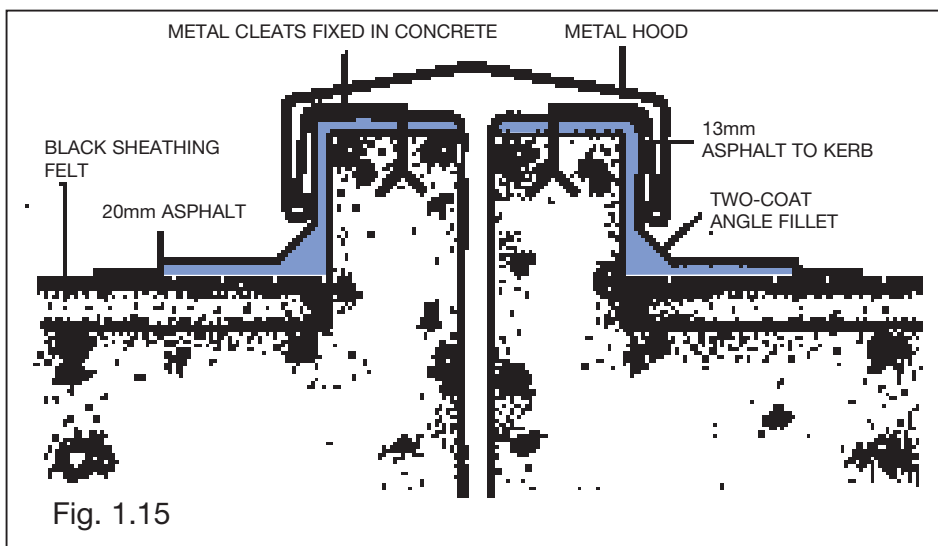

TYPICAL SPECIFICATIONS

In the following pages typical mastic asphalt specifications and details are illustrated for the most commonly encountered forms of flat roof construction.

The Protected Membrane Roof system is covered on pages 16 and 17.

Permanite Asphalt Technical Services can advise on any situation not covered by the following specifications.

CONCRETE DECKS

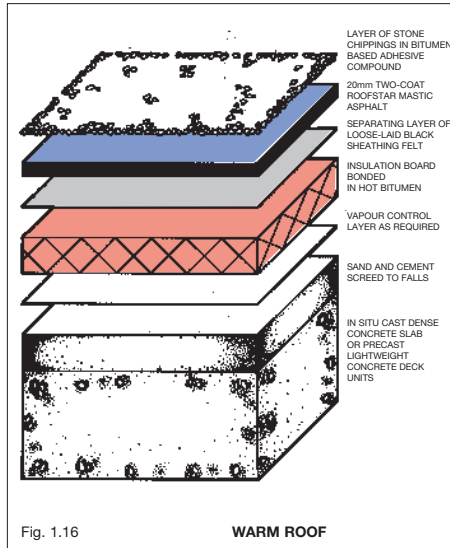

CONCRETE DECKS

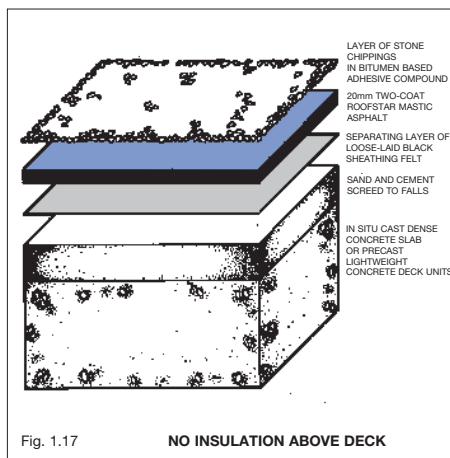

Roofing

CONCRETE DECKS

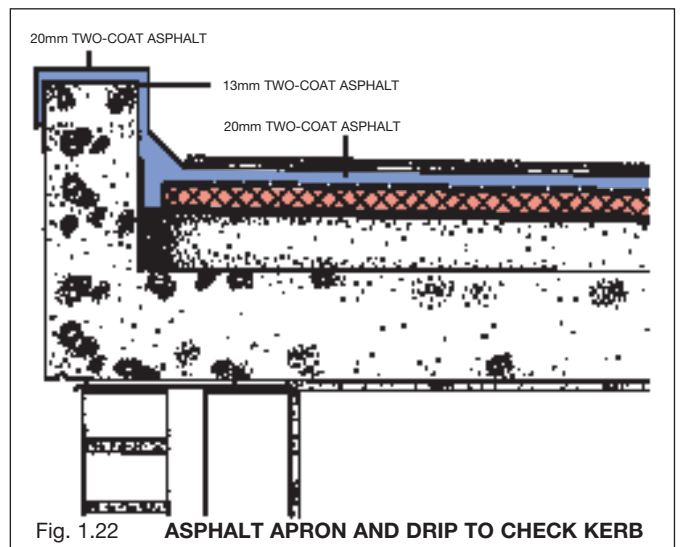
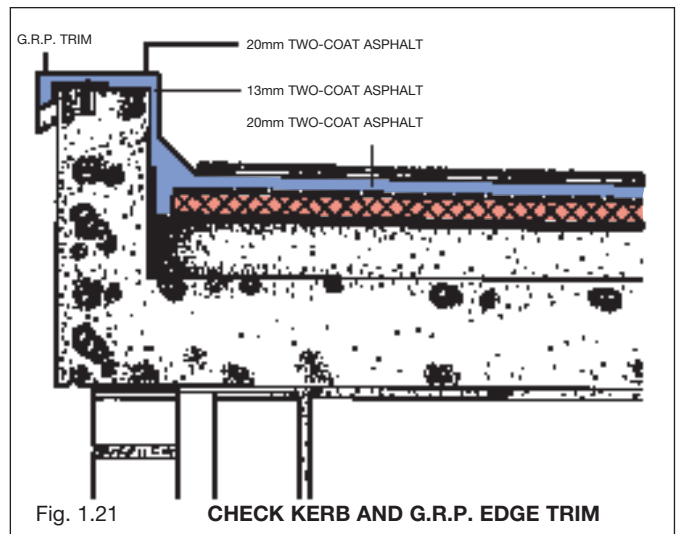
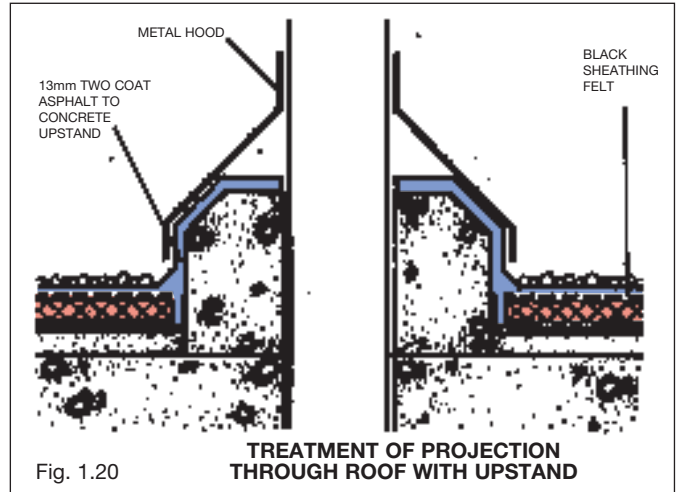
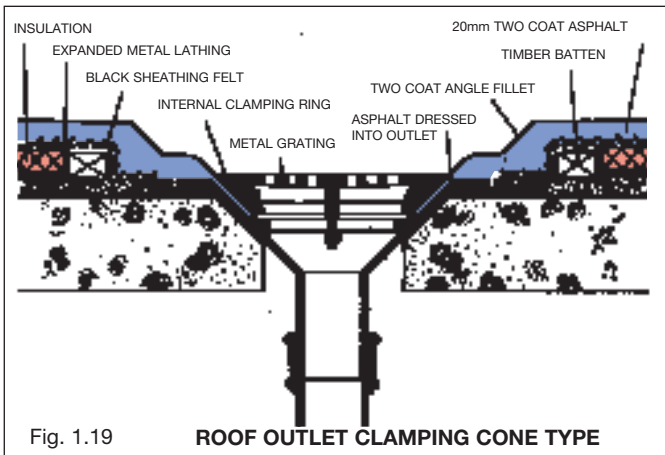
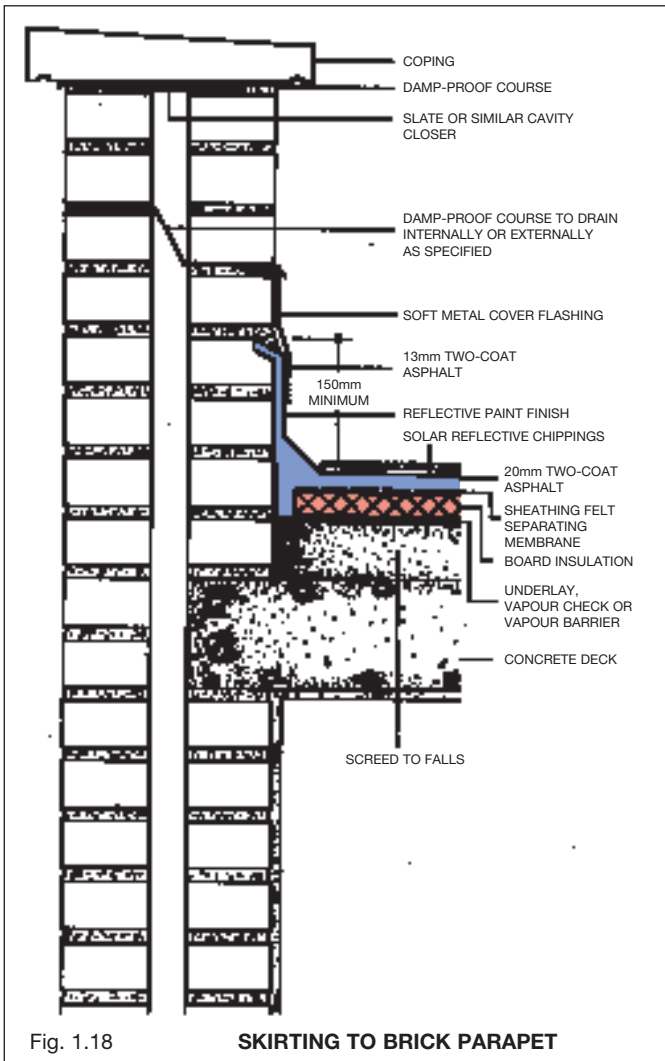

CONCRETE DECKS

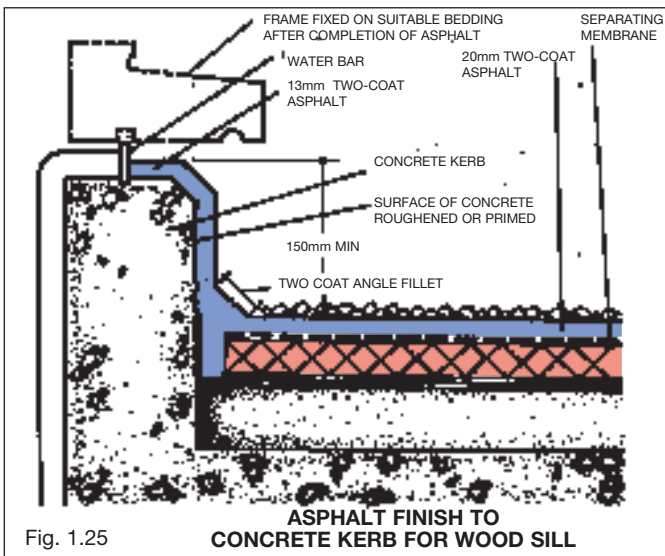
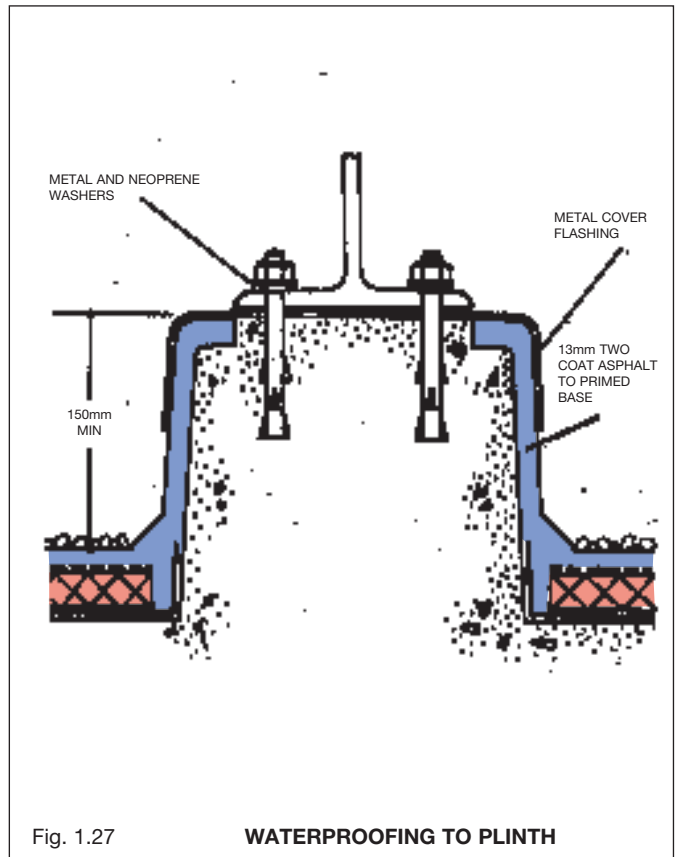
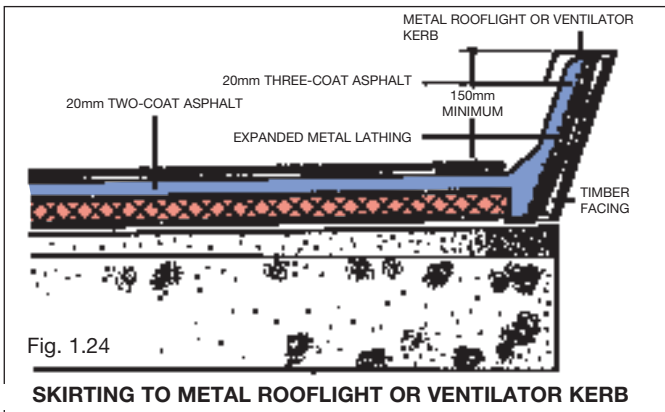
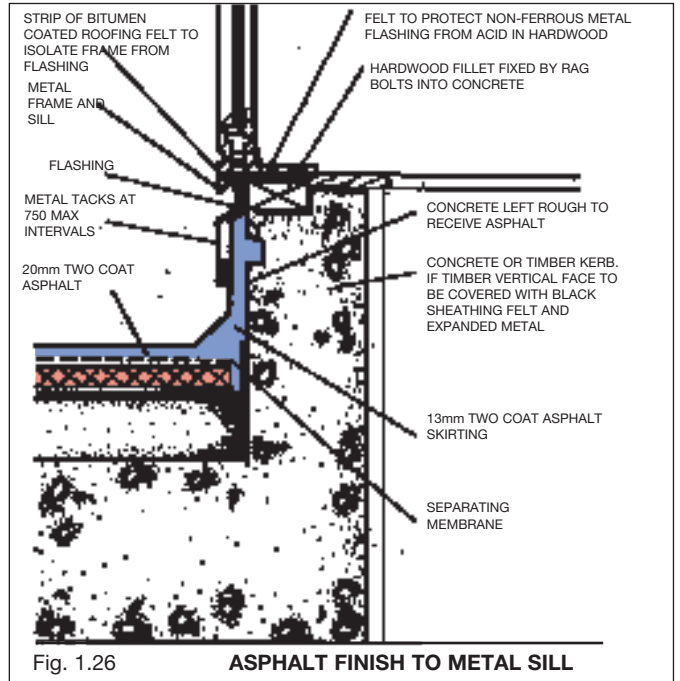
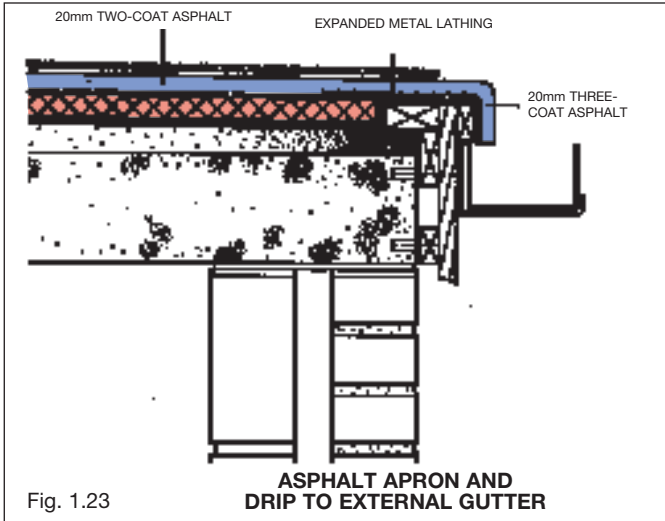
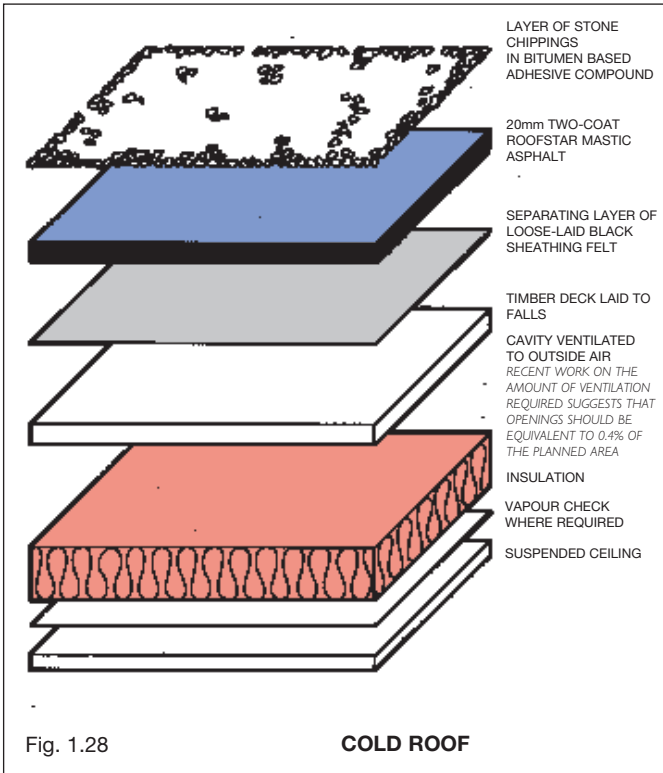

Fig. 1.25

Fig. 1.27

Roofing

TIMBER DECKS



WOODWOOL DECKS

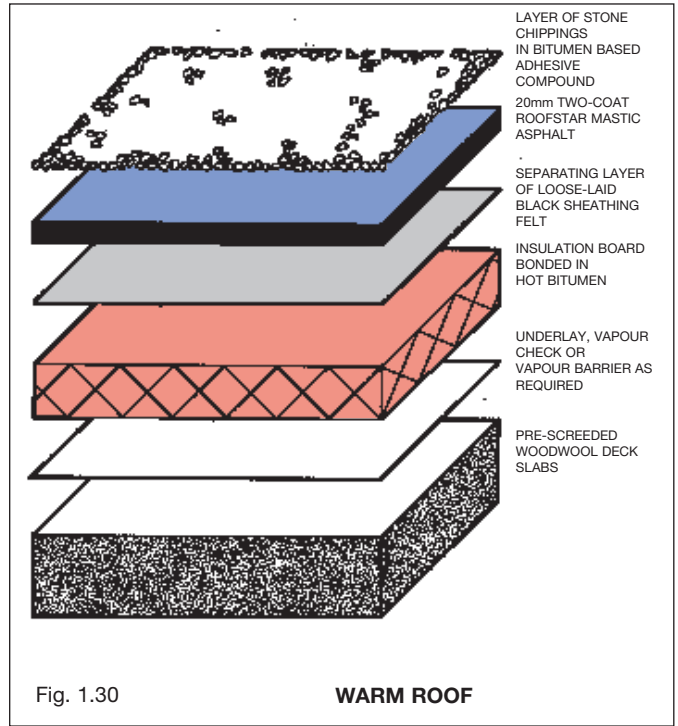

TIMBER DECKS

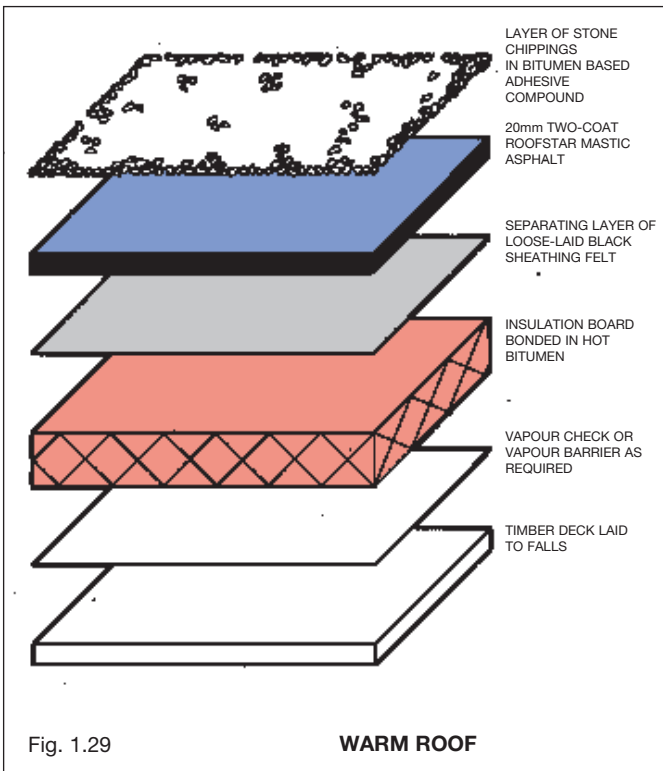

WOODWOOL DECKS

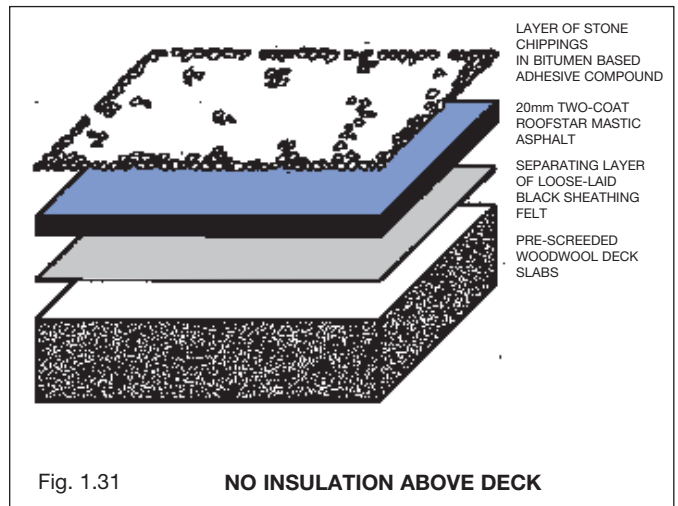

TIMBER/WOODWOOL DECKS

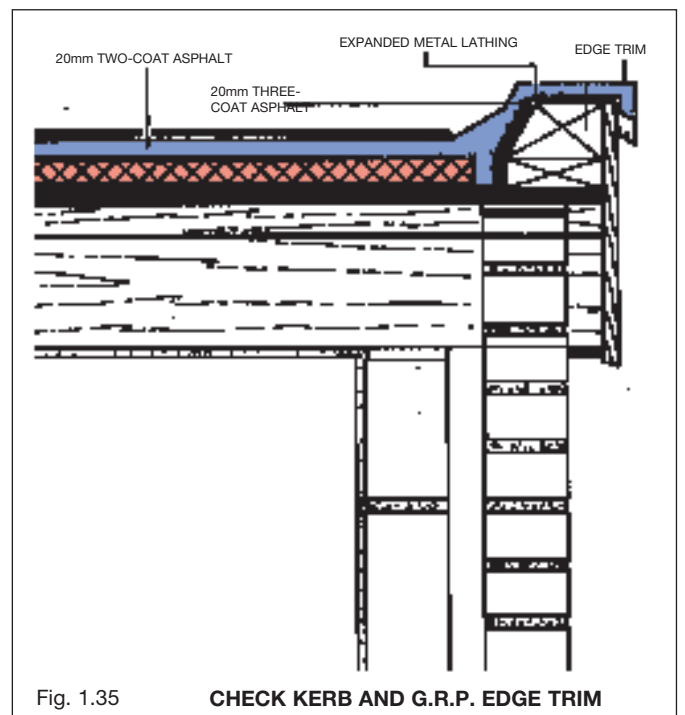
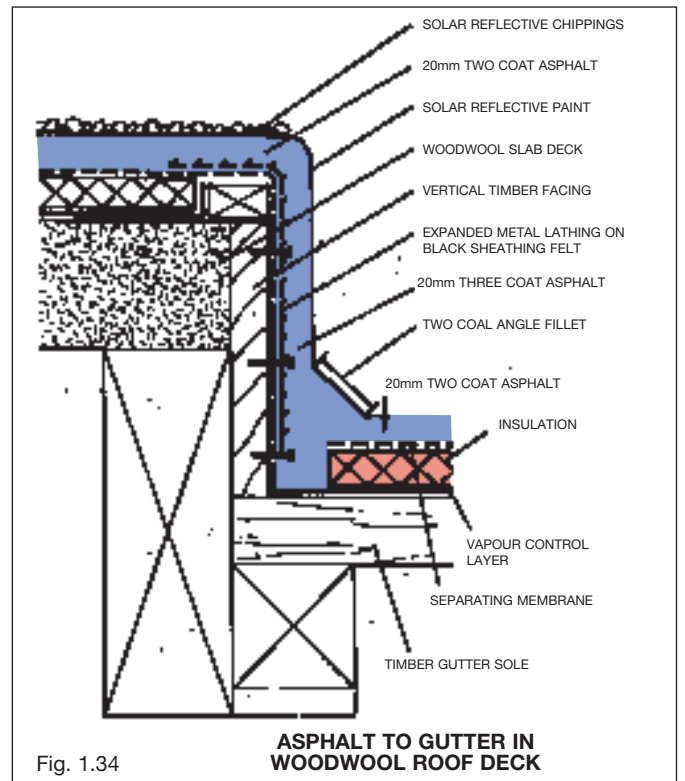
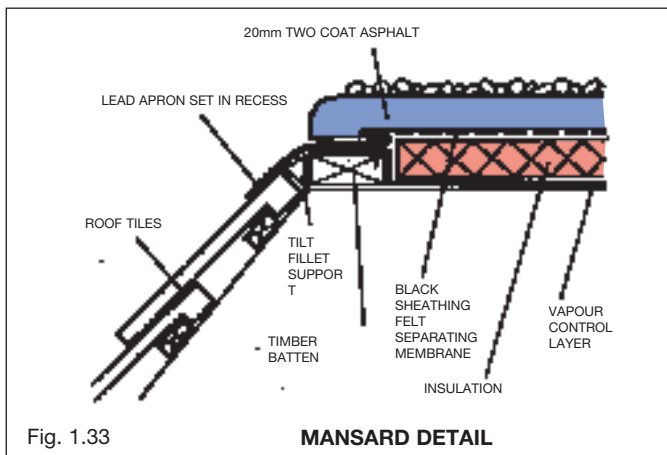
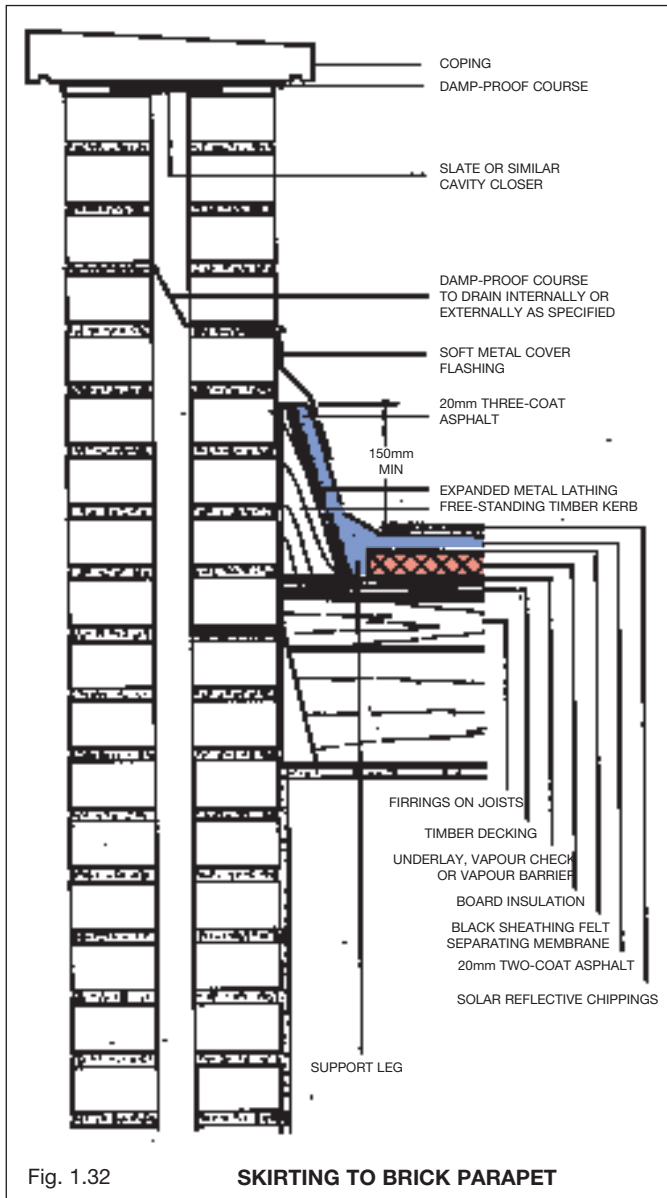

Roofing

TIMBER/WOODWOOL DECKS

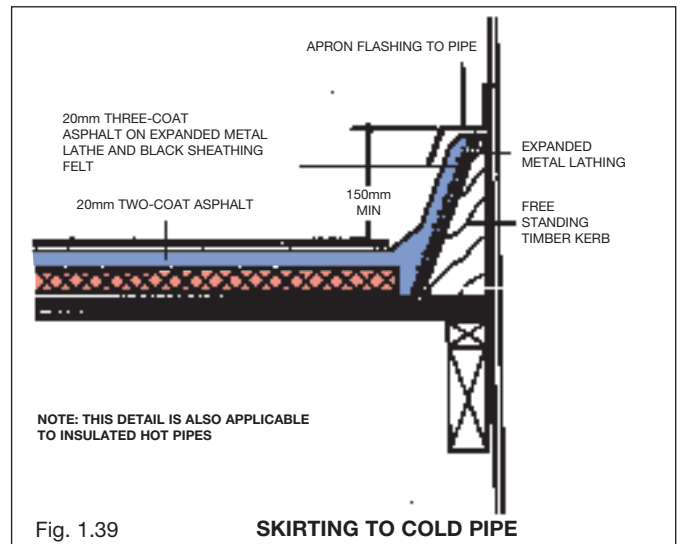
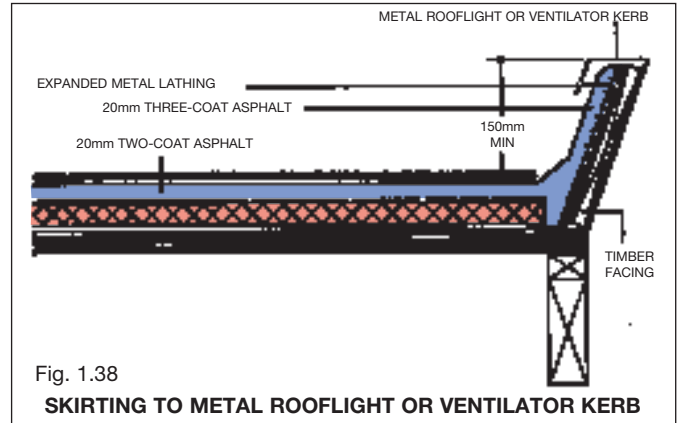
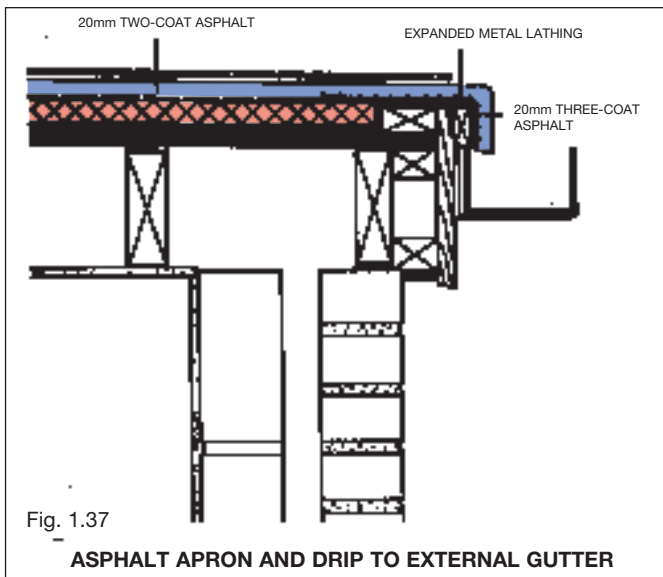
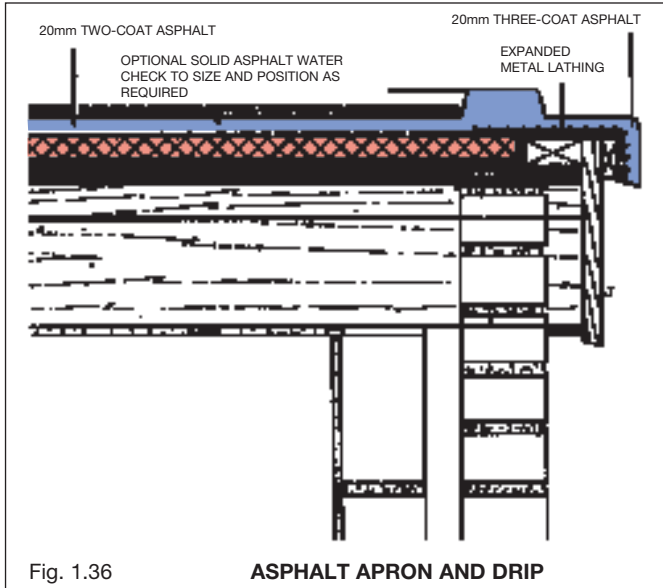

METAL DECKING

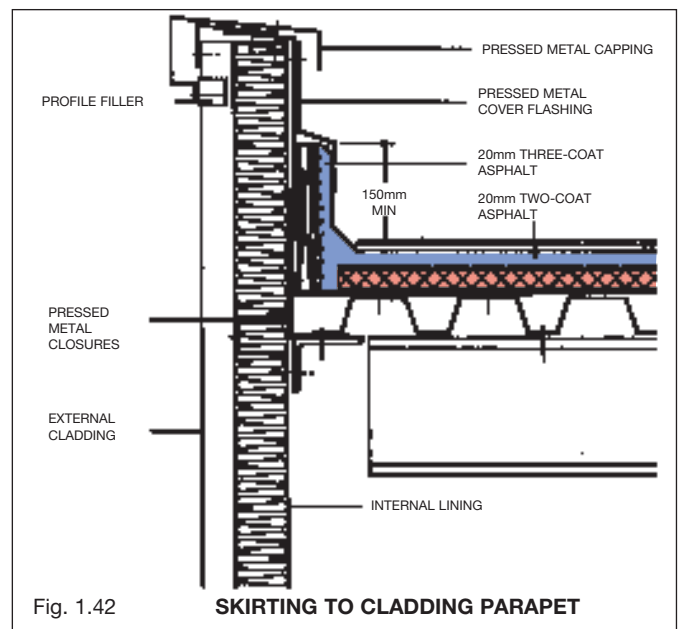
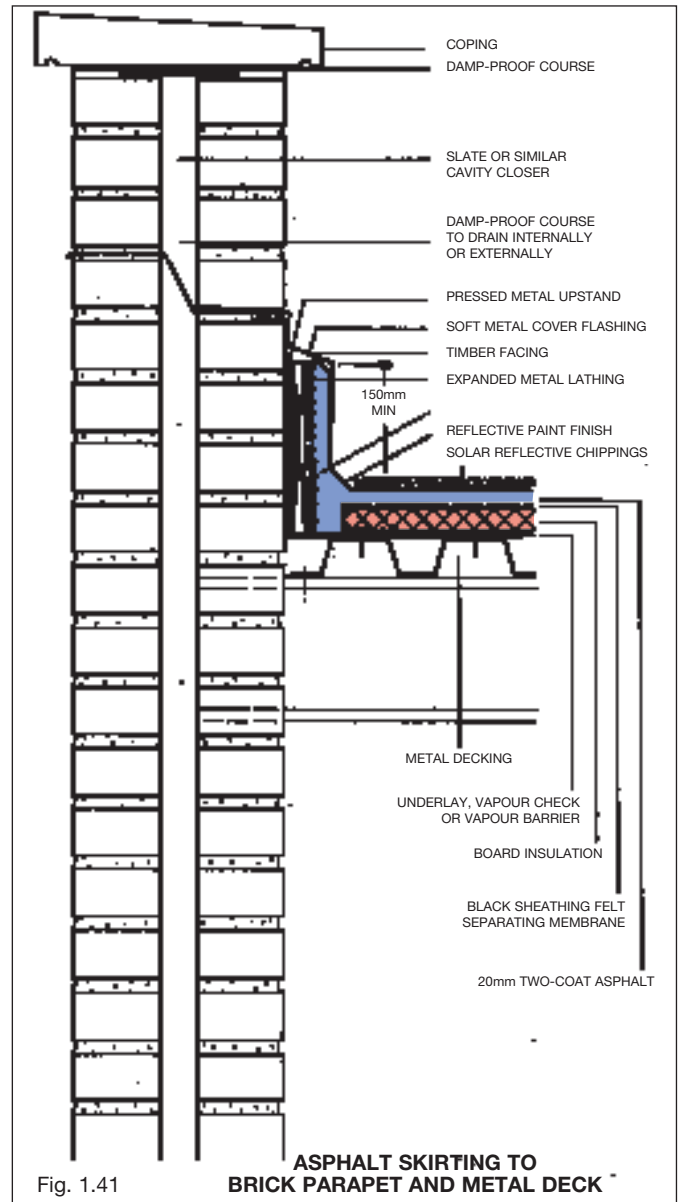
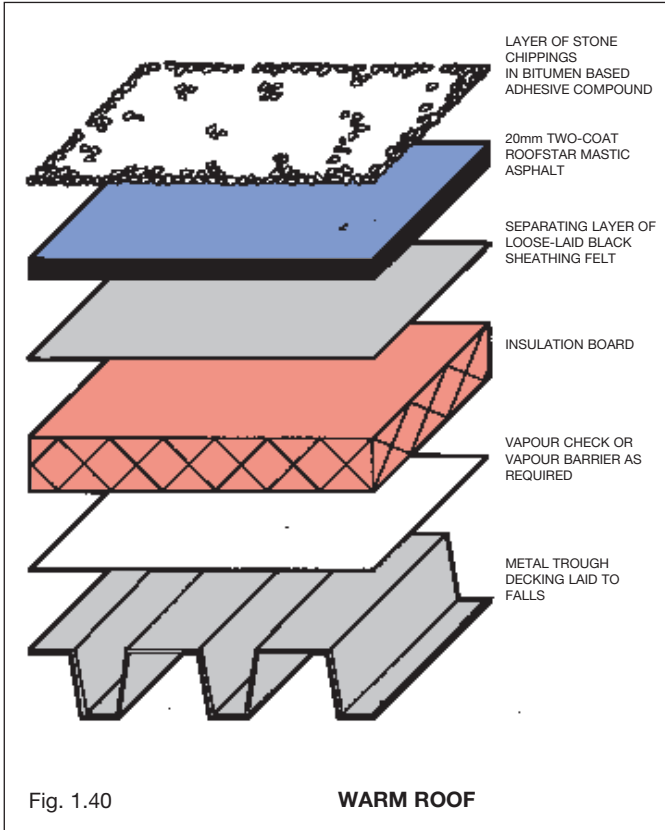

Roofing

METAL DECKING

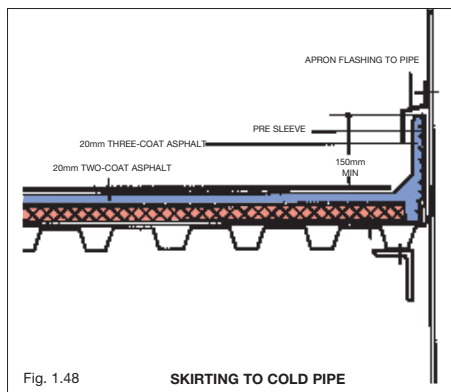
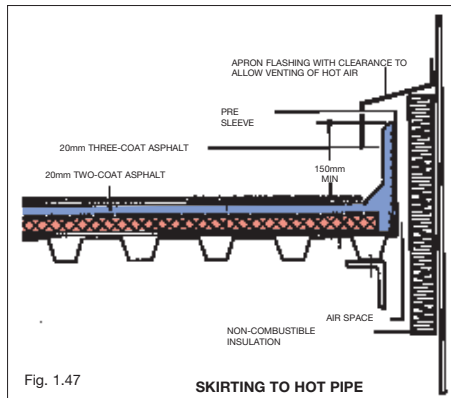
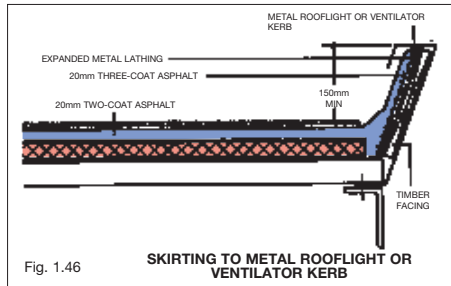
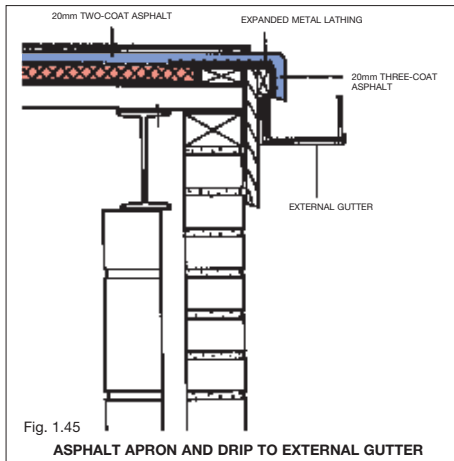
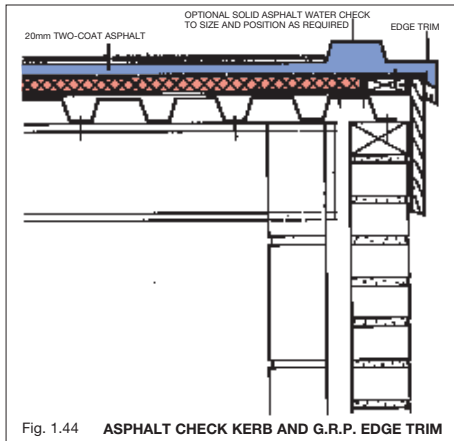
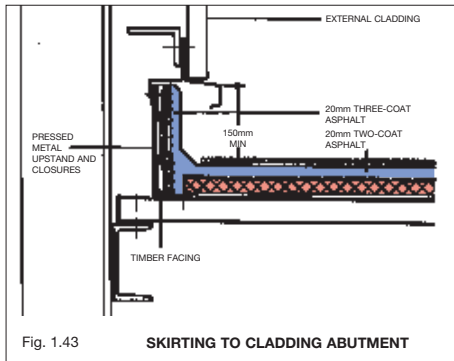

PROTECTED MEMBRANE ROOF

Consideration should be given to this form of construction especially where high thermal insulation is required.

The basic difference between the Protected Membrane Roof (also known as the Inverted Roof) and traditional flat roof construction is that the insulant is located above and not below the Asphalt membrane.

The system has significant advantages:

- The insulation acts as a protective layer to the asphalt waterproof covering.
- The asphalt and structure are protected against extremes of thermal change during winter and summer periods, giving considerable thermal stability to the roofdeck system.
- It is the ideal solution to the control of condensation problems.
- No separate vapour barrier is required.
- The System forms an ideal specification for insulated balconies and rooftop terraces.

REQUIREMENTS FOR THERMAL INSULATION

Extruded polystyrene boards are used in Protected Membrane Roof systems, loose laid and ballasted in accordance with manufacturers instructions.

To aid drainage, the asphalt membrane should be overlaid with a non-woven polyester fleece layer – 130-140g/m² with lap joints of 250-300mm. eg. Terram 1000.

When calculating board thickness to achieve a specific

U-value, it is necessary to allow for loss of efficiency once the board is installed due to the effect of rainwater draining below the insulation.

Manufacturers take this factor into account by recommending a 20% increase in board thickness.

This is allowed for in the table below.

Deck	U-Value	(W/m ² K)	
150mm in situ cast slab and screed	0.45	0.35	0.2
100mm precast lightweight concrete units	75mm	100mm	155mm
	50mm	75mm	140mm

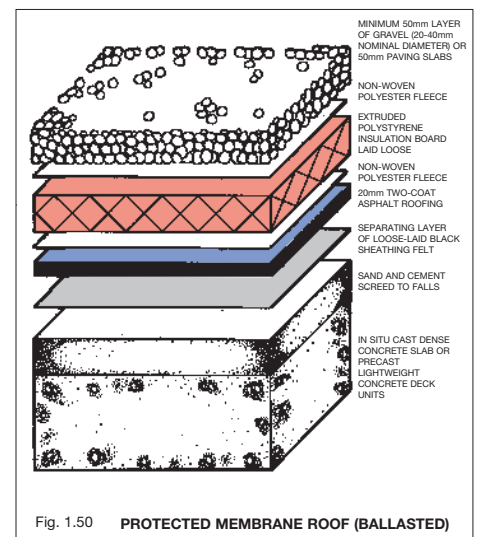
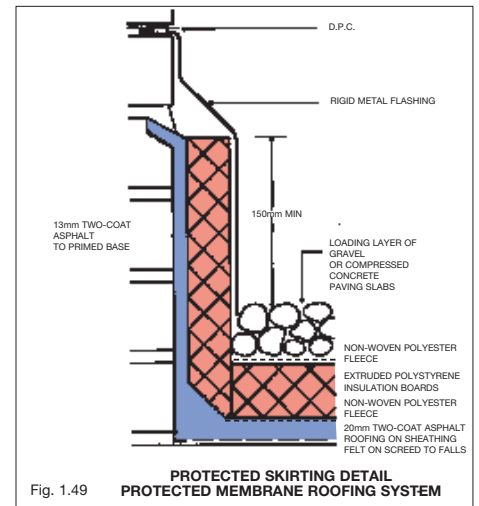

SURFACE PROTECTION

Protection for insulation in a traditional protected membrane roof is provided by minimum 50mm thick paving slabs or 20 to 40mm washed rounded gravel. The gravel layer should be at least 50mm deep and where insulation boards are in excess of 50mm thick a non woven polyester fleece e.g. Terram 1000 should be laid above the insulation.

Roofing

LIGHTWEIGHT SYSTEMS

Extruded polystyrene boards which incorporate a cementitious topping are used in lightweight protected membrane systems. The use of these boards represents a considerable weight saving over conventionally fully loaded systems. Advice on their use on any given project must be obtained from the manufacturer.

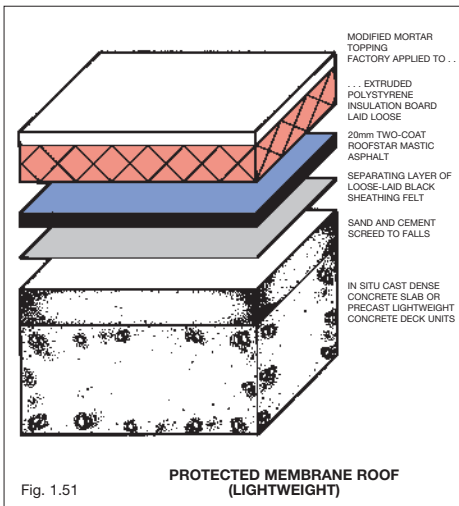

ROOF DECKS WITHOUT DRAINAGE FALLS

Where the substrate does not have a minimum finished fall of 1 in 80, 30mm three coat mastic asphalt should be specified.

SPECIAL APPLICATIONS

BALCONIES, TERRACES AND ACCESS DECKS

Falls must be provided to balconies and terraces to enable water to flow from the building. In all cases thresholds should be placed 150mm above the horizontal area to enable an asphalt skirting, turned into a chase at the top, to be formed to prevent the ingress of water. Work to handrails, gutters and outlets should be in accordance with details given on page 6.

Where asphalt is required as a paving to be exposed to the weather and subjected to foot traffic, it is laid in two coats. The first coat is laid to a nominal thickness of 10mm in roofing asphalt and the second coat 15mm in the same roofing asphalt incorporating an additional 10% to 15% by weight of 3mm coarse aggregate.

Where point loading is anticipated the surface should be tiled (Fig. 1.53).

Compressible insulation must not be used under Asphalt on balconies and terraces. A protected membrane system with paving slabs forms a suitable specification for insulated balconies. Alternatively Asphalt laid over Cellular Glass insulation and protected with promenade surfacing can usually be considered.

Advice on specific requirements is available from Permanite Asphalt Technical Services.

BALCONIES AND TERRACES

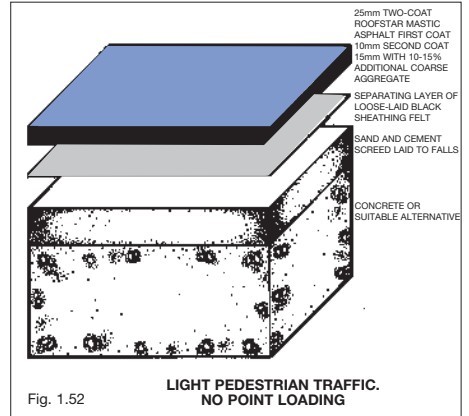

BALCONIES AND TERRACES

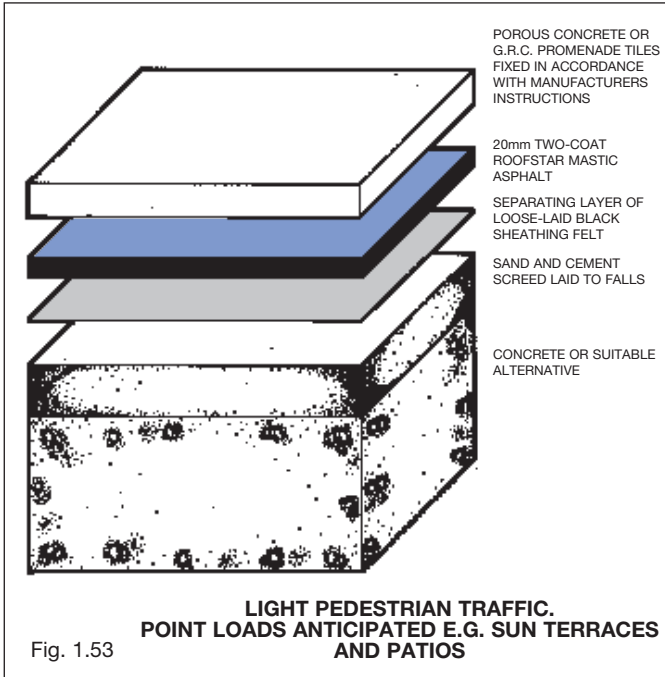

ACCESS DECKS AND PODIA

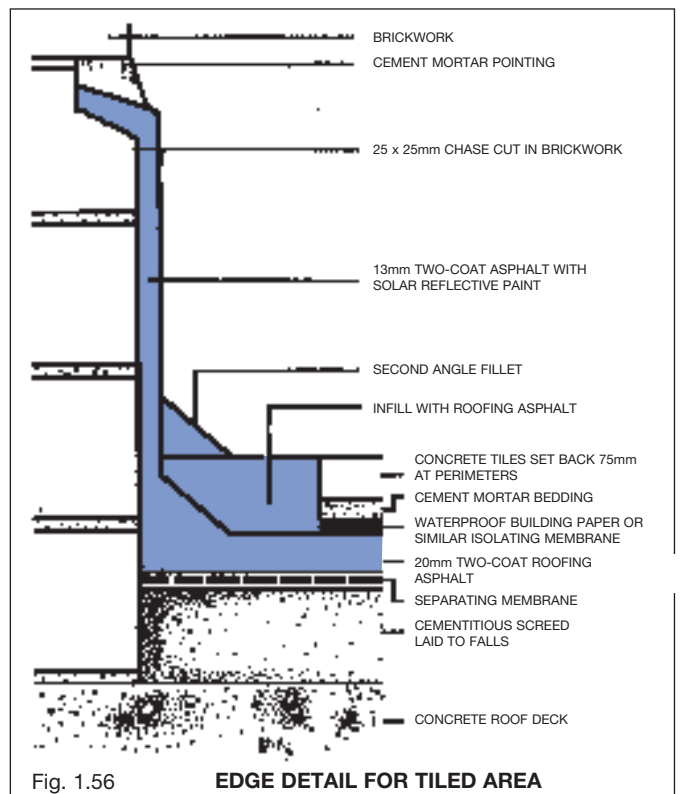
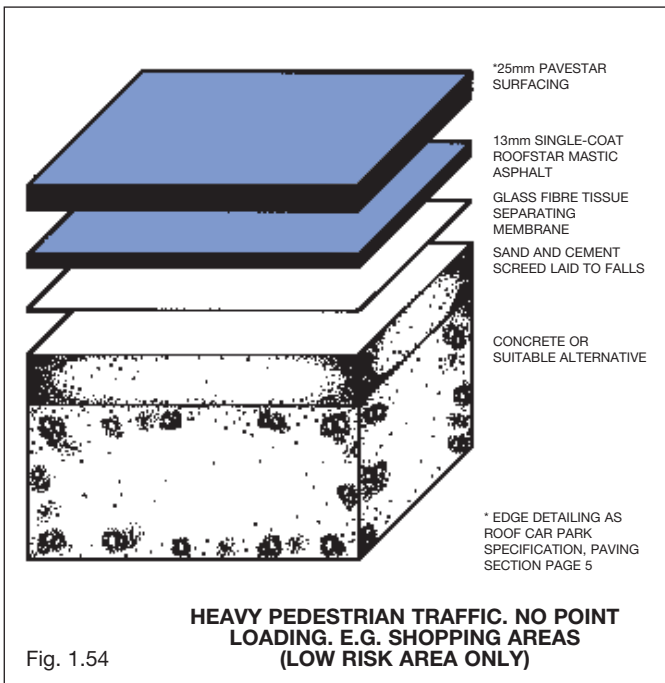
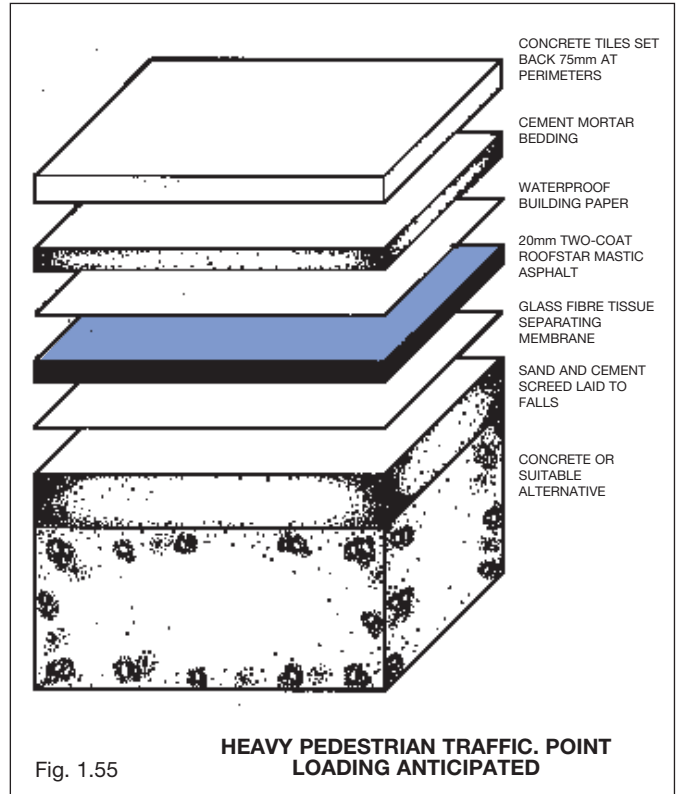

Roofing

ROOF GARDENS

Three-coat mastic asphalt is the most suitable specification for waterproofing to roof gardens and terracing where the location and repair of leaks will be difficult and expensive.

When designing roof gardens the following principles must be given attention.

- The asphalt should be protected by concrete slabs or a similar means from subsequent digging operations. An ideal alternative to concrete slabs is loose gravel laid on a glass fibre filtermat to prevent blockage of the outlets.
- All drainage should be provided at the asphalt water-proofing membrane level.
- All pedestrian areas should have adequate falls, preferably 1 in 50.
- On all horizontal areas left unburied the mastic asphalt should be suitably protected.

ROOFTOP CAR PARKS

Because of the overlap between roofing and paving, rooftop car parks are dealt with in the Paving section of this handbook.

REPAIRS AND MAINTENANCE

ROUTINE MAINTENANCE

As far as possible mastic asphalt roofs should be designed to avoid the need for maintenance, but inevitably some items of maintenance will occur.

An annual inspection of roofs is recommended and include the following.

1. Visual inspection for debris, leaves etc., and at the same time note the general condition of the roof.
2. Inspect gutters and outlets, cleaning gratings or wire cages.
3. Inspect flashings, trims, cappings and arrange for repair if they are loose. Inspect the pointing which holds flashings in position.
4. Check and ensure any displaced chippings are replaced.
5. If reflective paint was included in the original specification re-painting programmes will be required in accordance with the manufacturers recommendations.

REPAIR WORK

All repair work to a mastic asphalt roof must be performed by a specialist mastic asphalt contractor. If it is necessary to remove an area, the lines of the cuts should be covered with molten asphalt until the underlying material has softened. The asphalt should not be removed until this has taken place. Under no circumstances should a hammer and chisel be used to cut cold mastic asphalt. An angle grinder may, however, be used as an alternative.

The cut edge of the existing asphalt should be softened using molten asphalt and removed to half its depth for a width of approximately 75mm. A proper lapped joint with the relaid asphalt can then be formed.

Contents

TYPES OF MASTIC ASPHALT	PAGE 1
PREPARATION	PAGE 1
APPLICATION OF ASPHALT	PAGE 1
COMPRESSIBILITY OF ASPHALT	PAGE 2
DETAIL FINISHES	PAGE 2
SPECIAL APPLICATIONS	PAGE 4
OIL STORAGE IN BASEMENTS	PAGE 4
BOILERS AND FURNACES IN BASEMENTS	PAGE 4
REPAIRS AND MAINTENANCE	PAGE 4



Tanking

Introduction

Mastic asphalt, when used on underground structures, provides a continuous waterproof lining or 'tanking' to walls, floors and foundations, constructed in direct contact with the earth. In addition mastic asphalt is used for lining structures in water and sewage treatment works.

When fully confined it will provide an effective barrier to the transmission of water from the ground for the design life of the structure in which it is incorporated.

Acid resisting mastic asphalt tanking can also be used to line bund walls and emergency catchment areas where corrosive liquids are involved.

Tanking

TYPES OF MASTIC ASPHALT

Mastic Asphalt for Tanking and Damp-proof Courses (limestone aggregate) BS 6925: 1988 Type T 1097.

Although Kitemarked and covered by BSI Certification the following grades are manufactured to within much narrower requirements than those set out in the British Standard specification.

Permanite Asphalt manufactures an Acid Resisting Grade of Mastic Asphalt Tanking for situations where contact with acidic substances would occur. Please contact Technical Services for more information.

Tankstar B Product Code 4301 6925: 1988 Type T 1097/1/B	The most economic tanking grade with an asphaltic cement composition of 100% bitumen.
Tankstar T Product code 4302 BS 6925: 1988 Type T 1097/1/T25	The addition of 25% Trinidad Lake asphalt to the asphaltic cement composition gives improved laying qualities and greater thermal stability.

PREPARATION

FOUNDATIONS

Foundations for tanking below ground can be constructed of reinforced concrete, plain concrete or brickwork and should be designed in accordance with Code of Practice BS 8102

The concrete slab on which mastic asphalt tanking is applied should be designed and laid in a manner to ensure that any superimposed loads, such as protective screeds, concrete loading slabs and any plant, equipment or machinery subsequently used or installed, can be supported without deflection or other movement which could induce cracking in the mastic asphalt tanking.

The part of the structure on the inner side of the asphalt membrane must be capable of withstanding the water pressure to which it may be subjected from outside after the building is completed. (The pressure of water in kN per m² at any depth is 9.8 times the number of metres below water level.) In addition earth pressure must be allowed for.

SURFACE PREPARATION

Horizontal surfaces to which mastic asphalt tanking is to be applied should be level and free from irregularities such as ridges, dips, fins or concrete or mortar droppings. The surface of the concrete should, therefore, be given a wood-floated finish and be laid plane and true to allow the specified thickness of mastic asphalt to be applied uniformly.

Brickwork and concrete surfaces provided by timber shuttering are usually sufficiently rough to provide an adequate key for vertical asphalt. Smooth surfaces do not give a good key and if these cannot be avoided technical advice should be sought on the appropriate treatment.

External angles of concrete or brickwork must be rounded off to allow the full thickness of asphalt to be applied.

Chases must be provided for turning in the top of vertical asphalt unless the asphalt is being continued horizontally or as a damp-proof course.

key for vertical asphalt. Smooth surfaces do not give a good key and if these cannot be avoided technical advice should be sought on the appropriate treatment.

External angles of concrete or brickwork must be rounded off to allow the full thickness of asphalt to be applied.

Chases must be provided for turning in the top of vertical asphalt unless the asphalt is being continued horizontally or

as a damp-proof course.

CONTINUITY OF ASPHALT MEMBRANE

The structure must be designed so that the asphalt membrane forms a tank up to damp-course level without any breaks for stanchion bases, staircases, doorways or other openings.

Any openings for the passage of service pipes, drains, etc. may allow the penetration of water since such openings are not easily made watertight. If features of this kind cannot be avoided, provision must be made for all pipes to receive a sleeve of asphalt in two coats, before they are fixed in place by the main contractor, to enable the asphalter to form fillets round pipes (Fig 2.5).

PUMPING

It is essential that the site should be kept dry until the basement structure is completed. For this purpose, dewatering or pumping from carefully arranged sumps with appropriate drainage channels should be continuous whilst the laying of the mastic asphalt membrane is in progress and until all loading coats have hardened and the structure has developed sufficient strength to resist the full water pressure.

APPLICATION OF ASPHALT

Tanking asphalt must always be applied in 3 coats to a total thickness of 20mm for vertical work and 30 mm for horizontal work, in accordance with Code of Practices BS 8102.

Tanking should be laid directly to the substrate without a separating membrane. However, a separating membrane of glass fibre tissue, loose laid with minimum 50mm laps, may sometimes be necessary on horizontal areas to overcome excessive blowing of the mastic asphalt.

EXTERNAL TANKING

External tanking is defined as the application of an impervious membrane to the other surface of structural walls and the upper surface of a concrete base.

The excavations should be taken out, allowing a minimum of 600mm working space outside the walls. A sound concrete base must be provided and extended to give a 150mm set-off beyond the outside line of the structural walls, to enable an angle fillet to be formed between the horizontal and vertical asphalt. Immediately after the horizontal asphalt has been laid a protective sand and cement screed, at least 50mm thick, should be laid to prevent damage to the asphalt. horizontal loading coat of concrete, designed to withstand the maximum water pressure likely to be encountered after the building is completed, should then be applied as soon as possible.

When the structural walls have been built the vertical asphalt membrane is applied to their external faces, an angle fillet being formed at the junction of the horizontal and vertical asphalt. As soon as possible after the vertical mastic asphalt has been applied to the outside of a wall it should be protected against damage by the erection of a masonry wall or protective board. When the protective wall is of brickwork, blockwork or any form of masonry it should not abut directly against the asphalt but should be set back 40mm away from the vertical asphalt and the space flushed up course by course with mortar. (Fig 2.2) The vertical asphalt should be taken up at least 150mm above ground level.

INTERNAL TANKING

Internal tanking is defined as the application of an impervious membrane to the inner surface of structural walls and the upper surface of a concrete base.

When excavating for the underground structure approximately 300mm should be allowed outside the line of the walls and damp earth before the application of the asphalt. The concrete base and the walls must be structurally sound, whether of concrete or brickwork, and the walls should be built up to 150mm above ground level.

The horizontal asphalt membrane is laid to the concrete base and vertical asphalt is applied to the inner surface of the walls. An angle fillet is formed at the junction of the horizontal and vertical asphalt at all internal angles. A protective sand and cement screed, at least 50mm thick, should then be laid to prevent damage to the horizontal asphalt.

The loading coats, which should be designed to withstand the maximum water pressure likely to be encountered after the building is completed, should be constructed as soon as possible after the vertical asphalt has been applied.

When brickwork is used as a vertical structural loading coat it should be set 40mm away from the vertical asphalt to enable each course to be flushed up with mortar to prevent any voids occurring between the asphalt and the brickwork.

The presence of such voids can cause fractures to occur in the asphalt when the pressure of water is applied.

COMPRESSIBILITY OF ASPHALT DETAIL FINISHES

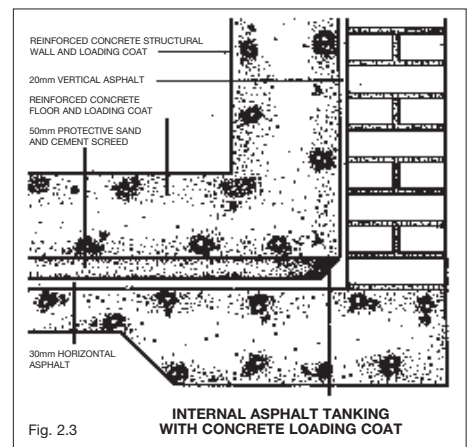
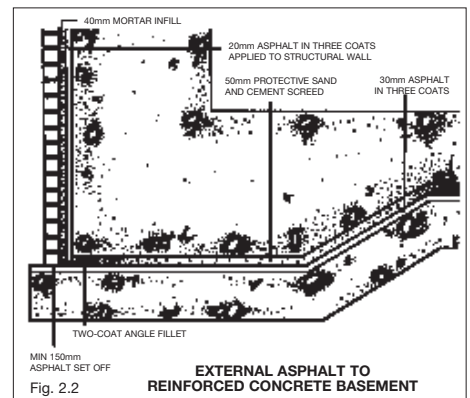
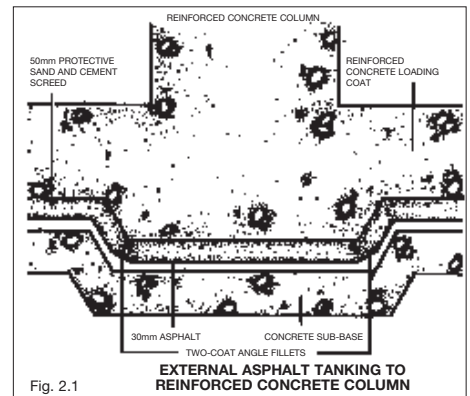

Tanking

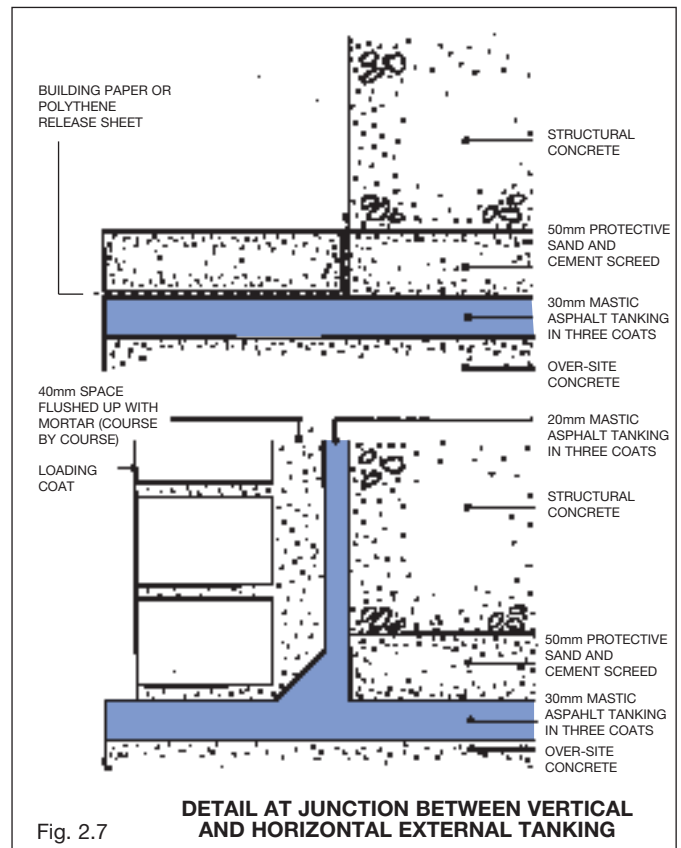
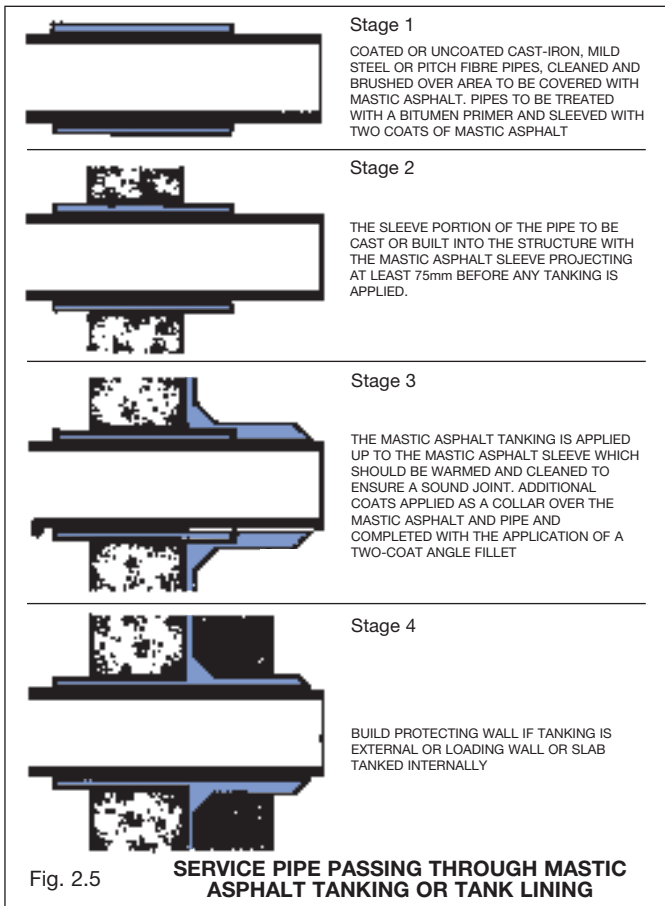
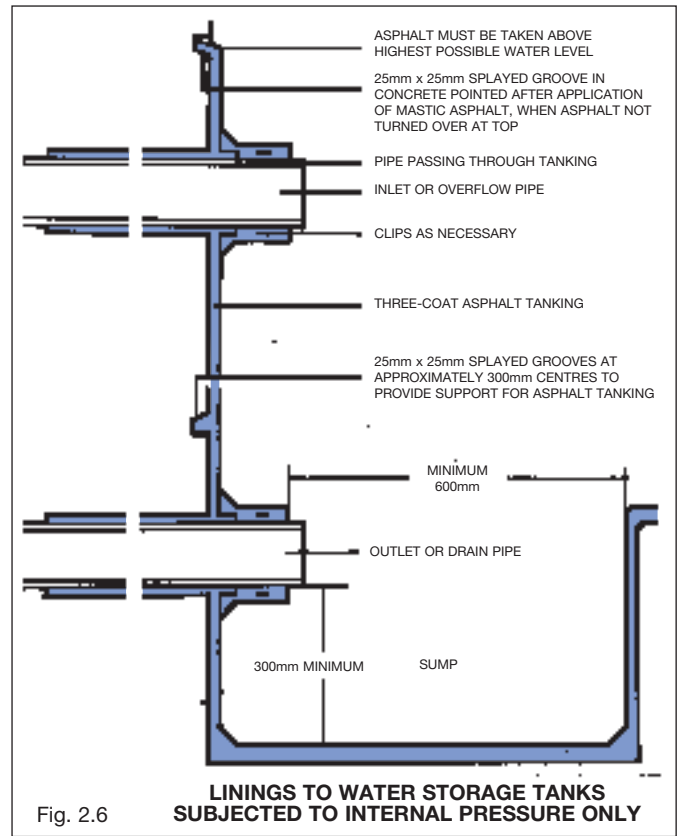
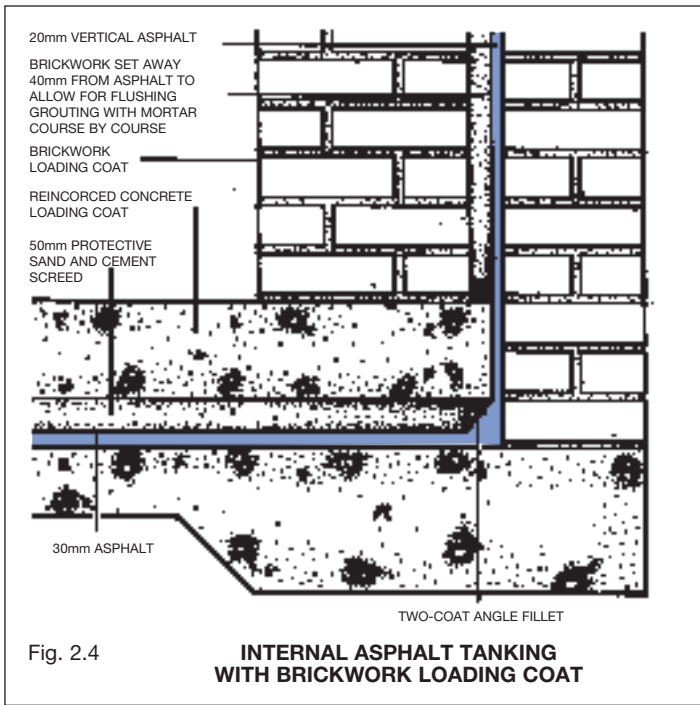

SPECIAL APPLICATIONS

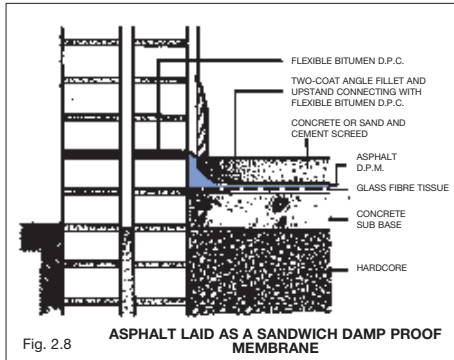

OIL STORAGE IN BASEMENTS

Mastic asphalt tanking will be seriously damaged by contact with oils. In tanked basements where fuel oil is stored or spillage of oils may occur provision should be made for an oil resisting lining which will resist saturation of the concrete loadings by oil leaks and consequent damage to the tanking.

BOILERS AND FURNACES IN BASEMENTS

Where a boiler or furnace is installed in a basement which has been tanked with asphalt, provision should be made for insulation beneath it. The insulation will prevent the transmission of excessive heat into the floor which might cause cracking of the concrete and possibly damage the asphalt membrane.

TANK LININGS

When a sump or manhole is not in a tanked area and is lined with mastic asphalt the frequent discharge of hot liquids combined with appreciable fluctuations in the level of the liquid in the tank may cause slumping of the lining. Provision should be made to provide permanent structural support for the mastic asphalt in the form of an inner brickwork lining.

REPAIRS AND MAINTENANCE

Where mastic asphalt tanking is to be repaired or joined to previously laid material making it necessary to cut into existing asphalt, the work must be carried out by a specialist mastic asphalt contractor.

When removing an area of asphalt, the lines of the cuts should be covered with molten asphalt until the underlying material has softened. The asphalt should not be removed until this has taken place. Under no circumstances should a hammer and chisel be used to cut cold asphalt. An angle grinder may, however, be used as an alternative.

The cut edge of the existing asphalt should be softened using molten asphalt and removed to two thirds of its depth for a width of approximately 75mm and to a third of its depth for a further width of approximately 75mm. A three layer lapped joint can then be formed between the new and existing asphalt.

Contents

BASES	PAGE 1
SEPARATING MEMBRANE	PAGE 1
TYPES OF MASTIC ASPHALT	PAGE 1
APPLICATION OF ASPHALT	PAGE 2
TYPICAL SPECIFICATIONS	PAGE 3
DETAIL FINISHES	PAGE 6
DECORATIVE FLOOR FINISHES	PAGE 7
MOVEMENT JOINTS	PAGE 8
REPAIRS AND MAINTENANCE	PAGE 8



Flooring

Introduction

Flooring mastic asphalts are manufactured to achieve performance characteristics from light domestic use through to heavy industrial duty and can be a self finished flooring or an underlay for tiles, carpeting, etc. A mastic asphalt floor provides a hard wearing, durable surface which will resist the passage of dampness and which can be brought into service as soon as it has cooled to ambient temperature.

The finish to mastic asphalt flooring is normally laid with a matt or natural float finish. Red variants are available throughout the Floorstar range.

Flooring

CONCRETE

Most forms of solid construction will provide a suitable base for Permanite flooring asphalts.

CONCRETE

Concrete surfaces, free from cracks or indentation, provide an excellent base for the application of flooring asphalt. They should be designed and constructed in accordance with the recommendations in BS 8204: Part 1. If the concrete surface is old and cracked it is necessary to use a separating membrane between the asphalt and the concrete. In the case of uneven concrete a levelling coat of asphalt or sand cement screed may be necessary.

CONCRETE BEAMS AND HOLLOW TILES

Where the base on which the flooring asphalt is to be laid is of precast concrete beams, hollow beams or hollow tiles, a sand and cement screed designed in accordance with BS 8204: Part 1 may be required.

STONE FLAGS, QUARRY TILES OR BRICK FLOORS

Old floors of these types can form a good base to receive asphalt flooring. However, it may be necessary to provide a levelling coat of asphalt to take up irregularities in the surface.

TIMBER BOARDING

Asphalt can be laid over timber boarded floors providing the structure is free from deflection. Minor deflection can be catered for by the inclusion of a 10mm cushion coat of roofing or tanking asphalt. In all cases a separating membrane of black sheathing felt is required.

METAL FLOORS

A thin coat of bituminous primer must be applied by the asphalter after the surface has been prepared. The asphalt is laid direct without the use of a separating membrane and to compensate for deflection a 10mm roofing or tanking layer should be specified as a cushion coat.

SEPARATING MEMBRANE

The purpose of a black sheathing felt or glass fibre separating membrane is to isolate the mastic asphalt from the base to allow for any relative movement between them. It also helps to prevent the formation of blisters and 'blowing' of asphalt.

The separating membrane is laid loose with 50mm laps.

Correct selection of the separating membrane is very important and full details are to be found in this section under Typical Specifications on page 3.

TYPES OF MASTIC ASPHALT

Mastic Asphalt for Flooring (limestone aggregate)

BS 6925: 1988 Type F 1076 and Type F 1451.

Although Kitemarked and covered by BSI Certification the following grades are manufactured to within much narrower requirement than those set out in the British Standard specification.

STANDARD GRADES

Special Hard

Floorstar S to BS 6925: 1988

Type F 1076/2/1 Product code 4200

Light Duty

Floorstar L to BS 6925: 1988

Type F 1076/2/11/B Product code 4201

Medium Duty

Floorstar M to BS 6925: 1988

Type F 1076/2/111/B Product code 4217

Heavy Duty

Floorstar H to BS 6925: 1988

Type F 1076/2/1V/B Product code 4208

Grades L, M and H are available with 25% Trinidad Lake asphalt which provides improved laying properties

SPECIAL GRADES

Permanite Asphalt has specialised products in its Floorstar range. Detailed below are a number of applications which can be catered for.

Acid and chemical-resisting asphalts.

Asphalts can be manufactured to withstand certain acids and other chemicals. Details of the chemicals, their concentrations and working temperatures must be provided. For further details please contact our Technical Services Department.

Oil-resistance

Where resistance to mineral oil contamination is required, please contact Technical Services.

Cold storage

Special asphalts are available to suit the conditions found in cold rooms and refrigerators.

Gritless asphalt

Special grades can be supplied for flooring in factories where explosives are handled and the use of a spark-proof material is essential.

Coloured asphalts

Where a decorative finish is required, for example in domestic premises, offices, schools and hospitals, Permanite flooring asphalts can be supplied in red throughout the Floorstar range.

Coloured asphalts

Where a decorative finish is required, for example in domestic premises, offices, schools and hospitals, Permanite flooring asphalts can be supplied in red throughout the Floorstar range.

FLOORING FOR UNHEATED BUILDINGS

Many internal floor areas fall outside the categories previously mentioned in that the buildings are unheated or subject to rapid changes in temperature e.g. sports halls and warehouses.

For these applications special flooring/paving grades are available which are less sensitive to temperature variations.

For advice on individual specifications contact Technical Services.

APPLICATION OF ASPHALT

The application of flooring asphalt should be in accordance with BS 8204: Part 5.

PREPARATION

If the asphalt is delivered in blocks and melted down on site any additional coarse aggregate is incorporated at this stage. Alternatively the asphalt can be delivered molten in a mobile mixer in which case any coarse aggregate is incorporated at the factory.

LAYING

The area to be covered is divided into bays of convenient size. The molten asphalt is then spread by means of a wooden float. Timber or metal gauges are used to obtain the required thickness.

Asphalt flooring is normally laid in one coat and special care is taken in effecting junctions between bays to provide a smooth and even surface. For suspended floors where wet processes will occur two coats are normally necessary, the first

coat being an underlay of roofing or tanking asphalt. (See page 5 Suspended Floors).

FALLS TO CLEAR WATER

Where wet processes or regular cleaning of the floor is a user requirement it is essential that careful consideration be given to the provision of adequate falls to channels and gullies to prevent ponding.

Falls are essential where acid and chemical resistant mastic asphalt is laid, in order to facilitate washing down. In shower rooms similar provisions are required.

PROTECTION OF THE SURFACE

The floor should not be subjected to traffic until the

mastic asphalt has cooled to ambient temperature. The finished asphalt surface should be protected against

damage from following trades and special care should be taken to avoid spillage of solvents, diesel fuel or paints.

Concrete, mortar, cement grout or plaster should not be mixed directly on the flooring.

DESIGN REQUIREMENTS

To help ensure accurate tendering the following information should be provided by the specifier:

- I. Use to which floor will be put and nature of heaviness of traffic.
- II. Loaded weight of trolleys, if any, stating size of wheels and type of tyre.
- III. Maximum weight of standing loads and area of contact with floor.
- IV. Details of any acids, other chemicals, greases, oils or solutions, including concentration and temperature, which may come into contact with the floor.
- V. Temperature of building if above or below normal.

This is particularly relevant on suspended floor applications where the slab may attain a relatively high temperature.

Mastic asphalt is a thermoplastic material. Its resistance to indentation will be reduced with increase in temperature. As they are liable to be damaged at very low temperatures, flooring grades should never be laid externally.

- VI. Details of floor finishes e.g. non-slip surface etc.
- VII. Any falls or drainage facilities required.
- VIII. Details of applied finishes and adhesives.
- IX. Details of fixtures and fittings, particularly where these penetrate the asphalt.

Flooring

TYPICAL SPECIFICATIONS

The following information allows the specifier to select the correct grade of mastic asphalt flooring and the appropriate type of separating membrane.

This list is by no means comprehensive and Technical Services can advise on any situation not represented in the following pages.

SPECIAL HARD (FLOORSTAR S)

Suitable for the following:

HOSPITAL WARDS, SCHOOLS, SHOP FLOORS to take movable racks, OFFICES, DOMESTIC FLOORS (see note 1) and SHOWROOMS (see note 2).

Note 1. For domestic floors mastic asphalt flooring may be used as a finished floor but as it is affected by fats, grease and vegetable oils it is intended only as an underlay to carpets, tiles etc. in kitchens.

Note 2. For commercial showrooms subject to rapid changes of temperature (e.g. areas with large sliding doors), it

is important that the specifier should contact Technical Services.

Note 3. The surface can either be sand-rubbed or natural float finished.

Specify Floorstar S – laid 15-20mm

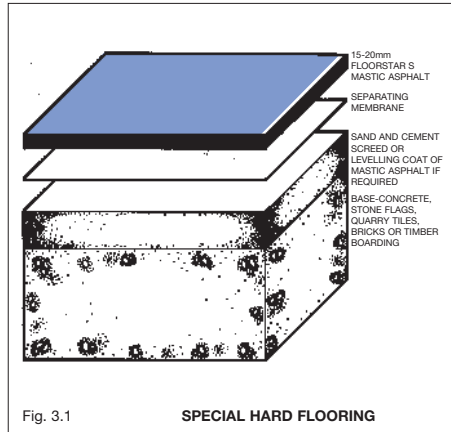

thickness in one coat.

Product code 4200

BS 6925: 1988 Type F 1076/2/1

As Floorstar S is designed for use in relatively high temperatures (25°-35°C) special care must be taken during laying.

The following practices are recommended in the application of Floorstar S.

I. The base to receive the asphalt must be sound and of a sufficiently even and accurate finish to permit the laying of the asphalt to constant thickness without 'bridging'.

II. Special Hard grade asphalts are more susceptible to the effects of thermal shock and must not be laid in open or unheated buildings when the ambient temperature is below 10°C or likely to fall below this value subsequent to laying. Rapid or uneven cooling caused by

draughts of air from external openings must be avoided.

III. Where the area to be covered requires multiple bays, these should be laid alternately to minimise the area of flooring cooling at any one time. In such cases, the remaining bays should not be laid until the contiguous ones have cooled to an ambient temperature.

IV. The laying should be planned so that the asphalt is not pinned in any way during the cooling period. Pinning is likely to occur at door thresholds and changes in wall direction that give an internal angle to the asphalt, or around stanchions, pipes, machine bases, etc. Appropriately positioned battens, set slightly away from the vertical surface involved, will allow free movement of the asphalt at these points, the asphalting to be completed after the removal of the battens.

Base

Concrete to BS8204 Part 1 with DPC below

Concrete to BS8204 Part 1 without DPC below

Timber boards (free from deflection)

Quarry Tiles Laid direct
Stone flags to earth
Bricks

Separating membrane

Black sheathing felt or glass fibre tissue

Glass fibre tissue

Black sheathing felt

Glass fibre tissue

For the above a levelling coat of mastic asphalt may be required or a sand/cement screed.

LIGHT DUTY (FLOORSTAR L)

Suitable for the following:

UNDERLAYS for other floor coverings, SHOP FLOORS (to take fixed racks), LIGHT ASSEMBLY FACTORY FLOORS (foot traffic only), DOMESTIC FLOORS (see note 1).

Note 1. If the flooring is to be laid in open or unheated buildings during the winter months or the temperature is expected to drop below 10°C, then the use of Floorstar L is accepted for domestic use, but its reduced resistance to indentation must be recognised. In all other situations such as HOSPITAL WARDS, etc. Floorstar S must be used.

Note 2. The surface can either be sand-rubbed or natural float finished.

Specify Floorstar L – laid 15-20mm thickness in one coat.

Product code 4201

BS 6925: 1988 Type F 1076/2/11/B

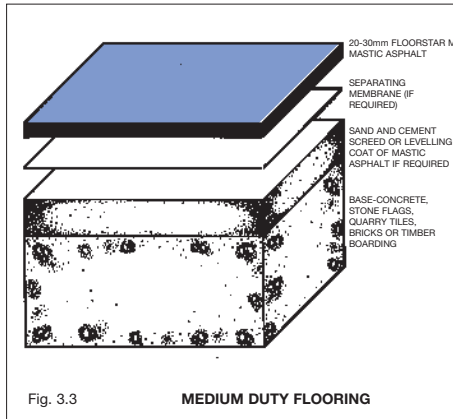
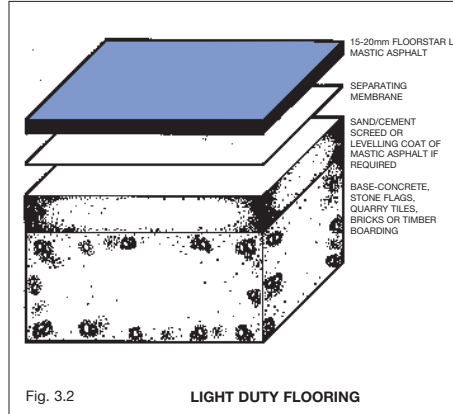

MEDIUM DUTY (FLOORSTAR M)

Suitable for the following:

FACTORY FLOORS – (Medium industrial. Note 1) HEAVILY FOOT-TRAFFICKED FLOORS, HOSPITAL CORRIDORS, HEATED SPORTS HALLS, CAR SHOWROOMS (Consultation with Permanite Asphalt Technical Services essential).

Note 1. The term ‘medium industrial’ indicates its suitability for continuous foot-trafficked floors, light hand trucks and trolleys. The surface can either be sand-rubbed or natural float finished.

Specify Floorstar M– laid 20-30mm thickness in one coat.

Product code 4217

BS 6925: 1988 Type F 1076/2/111/B

A variant of Floorstar M is manufactured for use in postal sorting offices. For details contact Technical Services.

Base		Separating membrane
Concrete to BS 8204 Part 1 with DPC below		Black sheathing felt or glass fibre tissue
Concrete to BS8204 Part 1 without DPC below		Glass fibre tissue
Timber boards (free from deflection)		Black sheathing felt
Quarry Tiles	Laid direct to earth	Glass fibre tissue
Stone flags		
Bricks		

For the above a levelling coat of mastic asphalt may be required or a sand/cement screed.

Base		Separating membrane
Concrete to BS8204 Part 1 with DPC below		Black sheathing felt or glass fibre tissue. Over 25mm the mastic flooring is either laid direct or on glass fibre tissue.
Concrete to BS8204 Part 1 without DPC below		Glass fibre tissue
Quarry Tiles		
Stone flags	Laid direct to earth	Glass fibre tissue
Bricks		
Timber floor		Black sheathing felt with 10mm Roofstar underlay as a cushion coat

For industrial buildings the base should be checked for load bearing strength.

Flooring

HEAVY DUTY (FLOORSTAR H)

Suitable for the following:

FACTORY FLOORS – heavy industrial
see note 1

LOADING SHEDS – internal

BREWERIES – see note 2

Note 1. The term 'heavy industrial' refers to floors subjected to mechanical trucks, trolleys, severe abrasion, heavy standing loads and floors subjected to impact.

Floorstar H is ideal for situations such as heavy engineering works, warehouses and most types of factory premises. The surface of the mastic asphalt flooring is usually sand rubbed to give a non-slip finish.

Note 2. As many varying conditions are present in breweries, such as rapid temperature changes, or washing with acidic detergent etc., contact Technical Services.

Specify Floorstar H- laid 30-50mm thickness in one coat.

Product code 4208

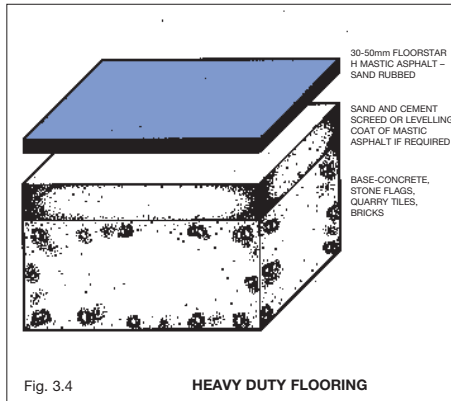

SUSPENDED FLOORS (WET PROCESS)

For special requirements such as suspended floors where a wet process is used, two coats are normally necessary, the first coat to be laid as a waterproof membrane (Roofstar or Tankstar) and the wearing surface of Floorstar L M H or S according to the type of traffic.

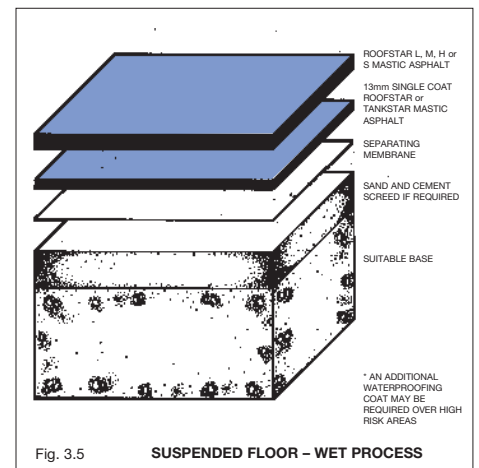

Base	Separating membrane
Concrete to BS 8204 Part 1 with or without DPC below slab	Laid direct to base without membrane.
Concrete if contaminated or cracked, or suspended floors for wet processes	Glass fibre tissue (consult Permanite Asphalt Technical Services)

IT IS ESSENTIAL THAT THE BASE ON WHICH THE MASTIC ASPHALT IS LAID SHOULD BE OF ADEQUATE LOAD BEARING STRENGTH

FLOORSTAR H grades are designed to have 6mm coarse aggregate incorporated to from 30-50% of the mastic as aid according to thickness. In the case of blocks this is ncorporated during re-melting on site. In the case of hot charge deliveries it is incorporated at the factory.

SKIRTINGS

The most commonly encountered detail is shown below.

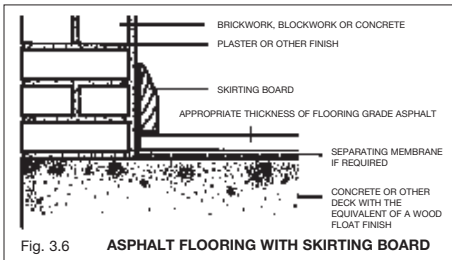

Asphalt skirtings are normally formed in roofing asphalt with a 2 coat angle fillet at the base. The detail illustrated below is suitable for areas subject to occasional washing.

ASPHALT SKIRTING TO SHOWER BATHS

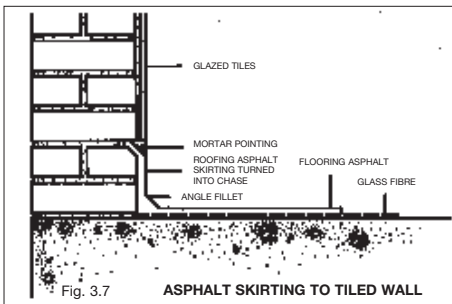

For areas subject to concentrated exposure to water (e.g. shower baths) the following details apply.

Treads and risers can be formed in asphalt or with non-slip tiles and tile risers. When the tiles are used it is recommended that an underlay of roofing or tanking asphalt be applied before the

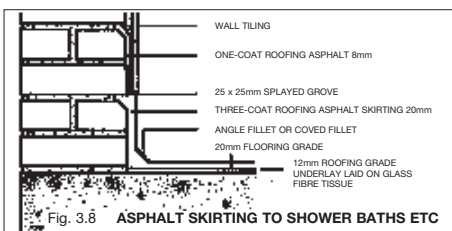

tiles are fixed.

SALT GLAZED AND HEAVY DUTY CHANNELS

Wherever hot water comes into contact with an asphalt floor, or where acid or chemical-resisting asphalt is used, any channels should be constructed with salt glazed channelling, of a type designed to allow the asphalt to be tucked into a groove.

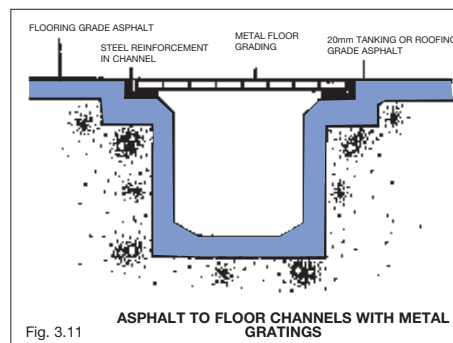
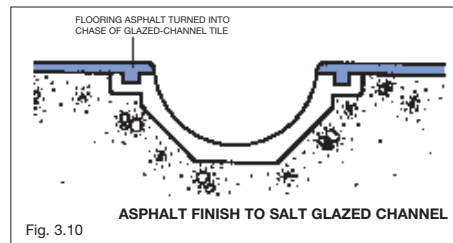
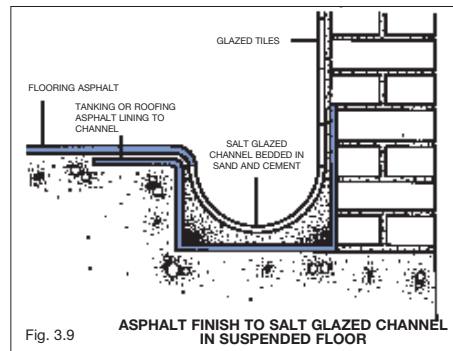

Flooring

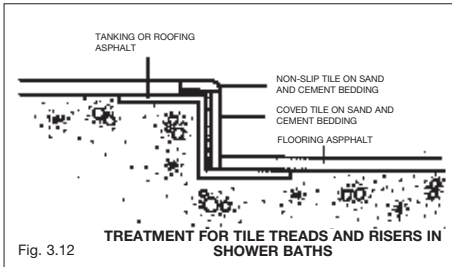

HEATING APPLIANCES

Appliances such as boilers in kitchens should be set on quarry tiles or concrete standings leaving a margin of about 300mm around the unit. In such cases a chase should be formed in the concrete foundation into which the asphalt can be turned.

CONTINUITY OF DAMPCOURSE

In the case of new buildings the flexible DPC used in the walls is continued over the separating membrane to connect with the mastic asphalt flooring.

When an existing building is being refurbished the addition of an asphalt skirting and fillet may be necessary.

DECORATIVE FLOOR FINISHES

Floorstar L and S are often used as underlays for carpets, tiles, woodblock, thin vinyl sheeting and cork etc.

One of the main advantages in selecting Floorstar as an underlay is that the

desired floor finish may be laid within a few hours of application of the mastic asphalt, eliminating waiting time for the floor screed and concrete floor to dry out.

In the case of refurbishment of existing properties it is possible to lay mastic asphalt on one day and lay the carpets on the next, causing minimum disturbance to the occupants of the building.

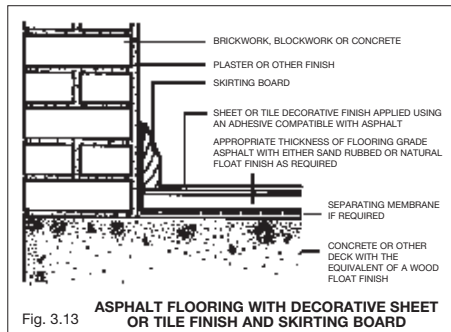

Fig. 3.13

As varying conditions of humidity frequently affect cork and woodblocks, close collaboration between the cork or woodblock supplier and the mastic asphalt contractor should be established when these materials are used as floor finishes.

FLOOR FINISH ADHESIVES

It is important that the adhesive used is recommended by the manufacturer of the floor finish material and is also compatible with mastic asphalt flooring when applied direct. Any new adhesives should be checked to establish whether they are suitable before being used in conjunction with mastic asphalt. A latex screed may be required on top of the asphalt prior to application of floor covering.

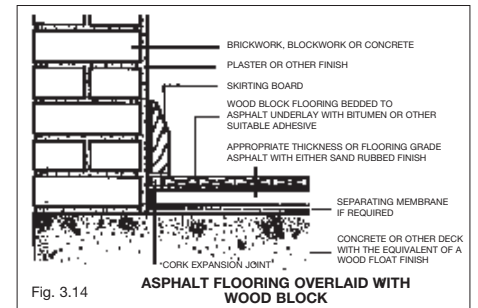

Fig. 3.14

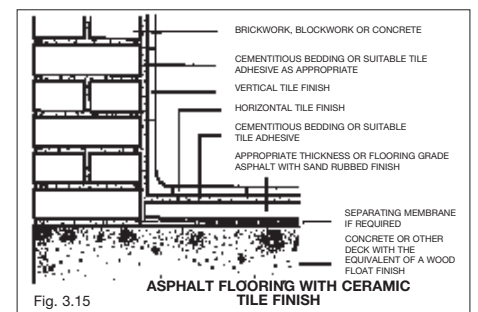

Fig. 3.15

MOVEMENT JOINTS

Allowance should be made for movement joints in mastic asphalt flooring where such joints are incorporated in the base on which the asphalt is applied.

Where floors will be cleaned by washing down, or are in wet process areas, movement joints should not be located at low points of falls or near to gullies or channels.

If a proprietary movement joint system is used it is essential to ensure that it is capable of accepting the expected type of traffic and degree of movement, that the materials of which it is made are compatible with mastic asphalt and that a secure and watertight joint can be made between the movement joint and the combined mastic asphalt waterproofing and flooring.

Where joints in the concrete base or screed are liable to move, they should be carried through the base and/or screed and the mastic asphalt to the floor surface by means of a proprietary movement joint profile. These vary in depth and thickness. Movement joint profiles should also be used between mastic asphalt and other types of flooring, and centrally over supporting beams and walls of suspended floors.

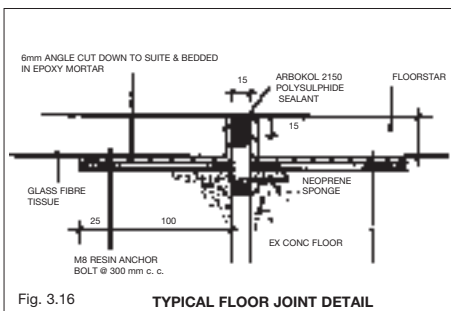

Fig. 3.16 TYPICAL FLOOR JOINT DETAIL

REPAIRS AND MAINTENANCE

A mastic asphalt flooring requires periodic, routine attention to obtain the maximum service and to maintain the best decorative effects. The user should be guided by the advice of the asphalt manufacturer or a reliable flooring contractor in the selection of suitable cleaning agents and polishes for the maintenance of the floor finish. Polishes should be of the emulsion type, free from solvents. Polishes in which wax is prepared in a paste form with a solvent should not be used.

Superficial dirt can normally be removed by washing or scrubbing with warm water and suitable detergents. Where there is much dirt on the flooring, the addition of a small quantity of washing soda to the warm water may be desirable. After the dirt has been removed the floor should be mopped with clean water. It is essential that all oils, fats and greases be removed as soon as possible.

When hosing down, a constant water temperature should be maintained with the water temperature not exceeding 40°C.

All repair work to a mastic asphalt surface must be performed by a specialist mastic asphalt contractor. If it is necessary to remove an area of mastic asphalt, the lines of the cuts should be covered with molten mastic asphalt until the underlying material has softened. The asphalt should not be removed until this has taken place. In no circumstances should a hammer and chisel be used to cut cold mastic asphalt. An angle grinder may, however, be used as an alternative.

Contents

TYPES OF ASPHALT	PAGE 1
COARSE AGGREGATE REQUIREMENTS	PAGE 1
MULTI-STOREY AND ROOF-TOP CAR PARKS	PAGE 1
HEAVY VEHICLES ACCESS AND STANDING	PAGE 3
RAMPS	PAGE 4
SURFACE FINISH	PAGE 4
DETAIL FINISHES	PAGE 5
DRAINAGE DETAILS	PAGE 5
BALCONIES AND TERRACES	PAGE 6
FOOTPATHS AND PROMENADES	PAGE 6
EXTERNAL LOADING BAYS	PAGE 6
ROADS AND BRIDGE	PAGE 6
REPAIRS AND MAINTENANCE	PAGE 6



Introduction

Mastic asphalt paving is more resistant to wear and deformation than hot rolled asphalt and can be used to surface walkways, car ports, HGV Service decks as well as heavily stressed areas such as loading bays.

Although commonly used externally, mastic asphalt paving is an ideal internal surfacing material for unheated buildings.

Paving

TYPES OF ASPHALT

Mastic asphalt for paving (limestone aggregate)

BS 1447: 1988.

Although kitemarked and covered by BSI certification the following grades are manufactured to within much narrower requirements from those set out in the British Standard specification.

Pavestar B Product code 4400 BS 1447/I/B/S	The basic paving grade with an asphaltic cement BS composition of 100% bitumen, providing proven performance at an economic price.
Pavestar T Product code 4403 BS 1447/I/T50/S	The addition of 50% Trinidad Lake asphalt to the asphaltic cement composition provides improved wearing characteristics, and greater thermal stability.
Pavestar H Product code 4405 BS 1447/I/T50/H	Heavily stressed areas.

STANDARD GRADES

SPECIAL GRADES

Permanite Asphalt also manufactures special grades in its Pavestar range, to include:

RED ROAD paving – BRIDGE DECK paving – MILITARY TANK paving – ACID RESISTING paving.

The Permapark range of Polymer modified car park systems has been developed to meet the demands of modern construction. Permapark offers total compatibility between the waterproofing and paving elements with even higher performance characteristics than British Standard grades.

For further details please contact Technical Services.

COARSE AGGREGATE REQUIREMENTS

British Standard 1447, which covers paving grade asphalts, deals with the composition of asphaltic cements and coarse aggregate additions, which vary to achieve the required wearing surface properties at various laid thicknesses. These coarse aggregate additions can be made either during manufacture when delivered in bulk as hot charge or on site when the base mastic asphalt blocks are remelted.

The following table sets out suggested thicknesses with the proportion and size of coarse aggregate.

The coarse aggregate content is expressed as a percentage by mass of the as-laid material. The following formula may be used to calculate the amount of coarse aggregate required:

$$\text{Mass of coarse aggregate required} = \frac{\text{Tonnage of as-laid material required}}{100} \times \text{Percentage of coarse aggregate}$$

Use	Coarse Aggregate		
	Thickness	% by Weight	Size mm
Footpaths	20mm	20	3
	30mm	30	3
Road Surfacing	40mm	45	10
Car Parks	25mm	30	6
	30mm	35	10
Loading Bays	40mm	45	10

The mass of coarse aggregate has to be deducted from the tonnage of as-laid material required to give the mass of mastic blocks required.

MULTI-STOREY AND ROOF-TOP CAR PARKS

This section covers all major car park specifications – insulated, uninsulated, exposed and internal decks.

UN-INSULATED DECKS

EXPOSED DECK

Where asphalt is to be used as the paving on an exposed deck it is laid in two operations. An underlay of roofing asphalt is first laid in two coats to a total thickness of 20mm, on a separating membrane of glass fibre tissue (Fig. 4.1).

A wearing surface of paving asphalt is then laid 25mm or 30mm thick and this should be set back 100mm from the perimeter with an infill of roofing asphalt incorporating a further angle fillet to the skirting (Fig. 4.9).

NOTE: In low risk situations e.g. above another car parking deck, the roofing underlay may be reduced to 10mm thick in one coat (Fig. 4.2).

INTERNAL DECKS

Where a floor in a multi-storey car park is to be subjected to wet conditions, such as hosing down, it is necessary for an underlay of roofing asphalt to be laid before the paving asphalt is applied.

The roofing asphalt is laid to a thickness of 10mm in a single coat on a separating membrane of glass fibre tissue. The paving asphalt is laid 25mm or 30mm thick in one coat direct to the roofing asphalt (Fig. 4.2). Asphalt skirtings and angle fillets are completed in the normal way with roofing asphalt.

On internal levels not subjected to wet conditions the paving asphalt and separating membrane are generally laid direct to the structural deck without a roofing underlay (Fig. 4.3).

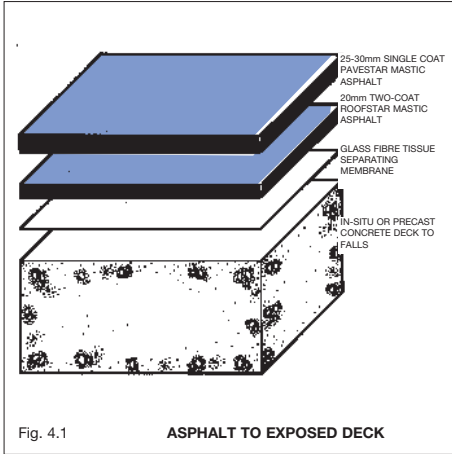

INSULATED DECKS

High density extruded polystyrene insulation is laid direct to the float finished structural base. Boards are loose laid and tightly butted at all joints and to abutments. A 75mm overlay of lytag/sand concrete grade 20, is used with a wood float finished surface, reinforced with steel wire mesh to BS4483 type A 142 at mid-height of the concrete overlay. A minimum 150mm overlap between sheets and wire ties at 600mm maximum centres is required.

The specification shown in Fig. 4.4 incorporates 50mm thickness of insulation to provide a U value of approximately 0.45 (w/m²K) for the total construction.

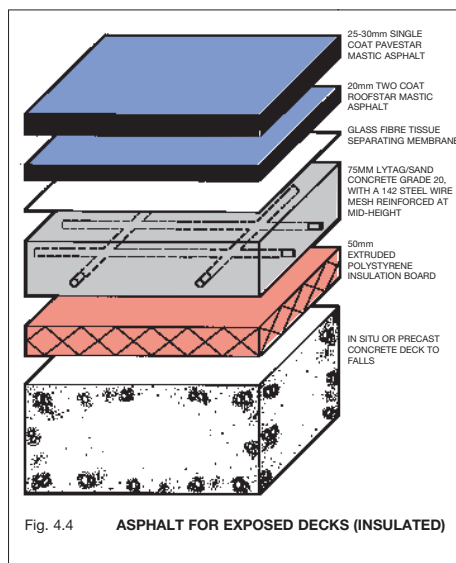
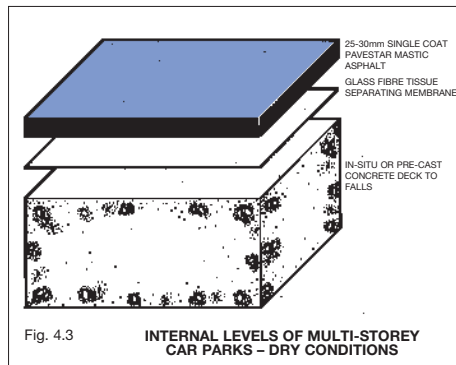
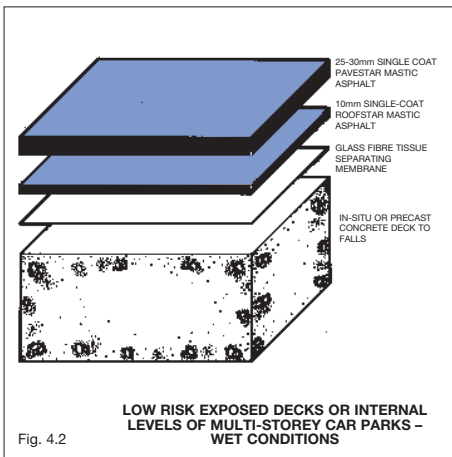

Paving

HEAVY VEHICLES – ACCESS AND

In areas where standing loads of a high order are anticipated, such as elevated service areas to shops etc., the thickness of the paving grade asphalt should be increased to 40mm. Incorporating 45% 10mm coarse aggregate.

STANDING

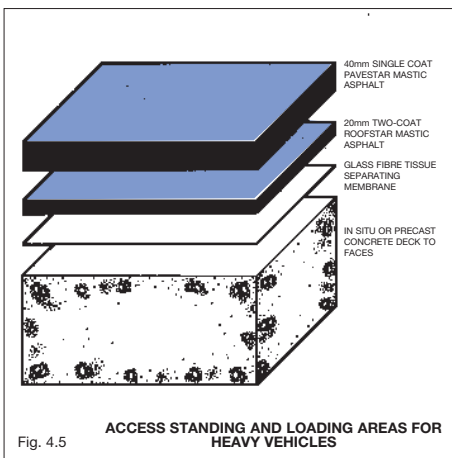

UN-INSULATED DECKS

INSULATED DECKS

This specification differs from the insulated car park system in that the thickness of the lytag concrete is increased to 100mm.

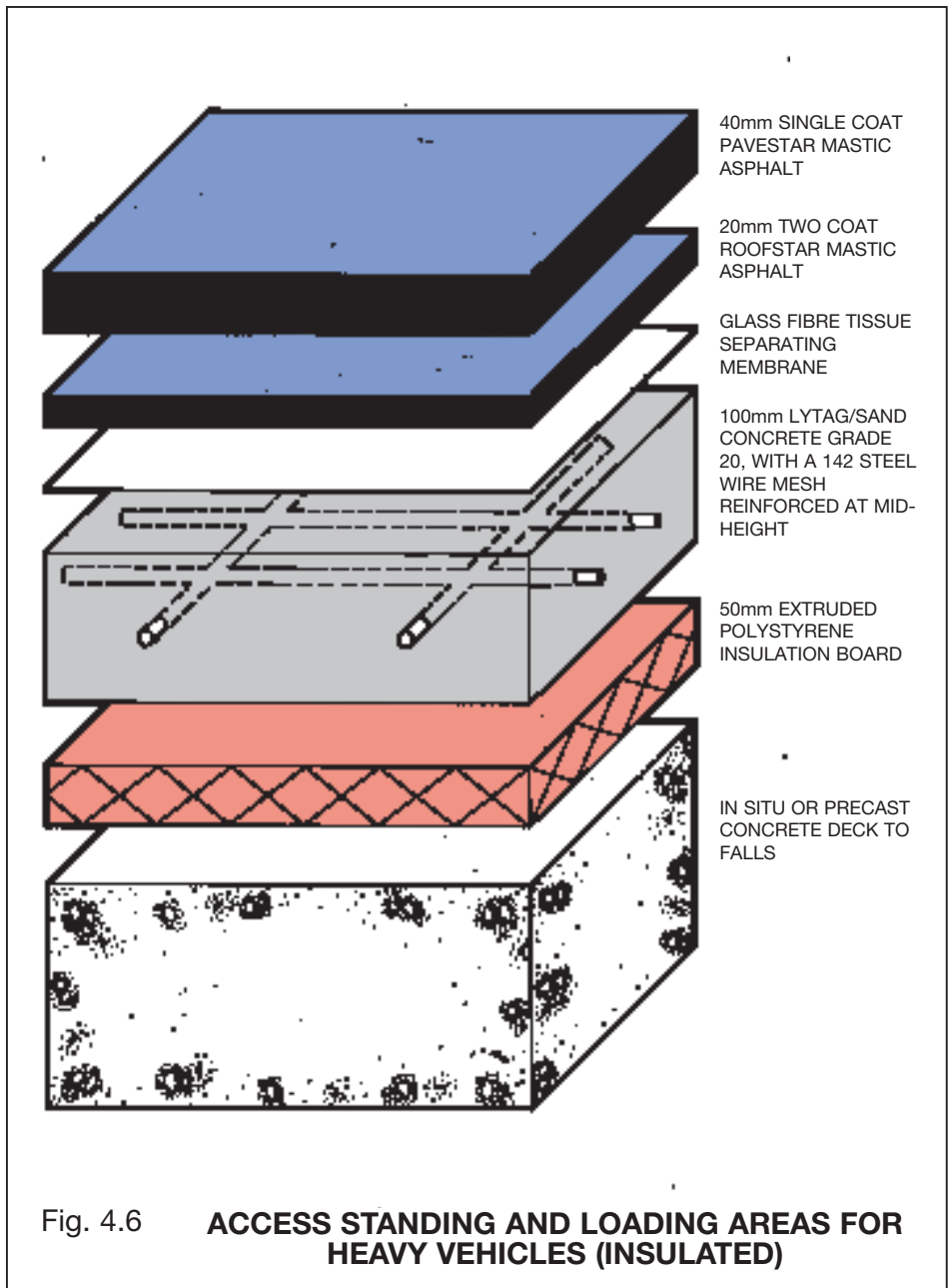

RAMPS

An asphalt surface can be provided to car park ramps with gradients not exceeding 1 in 10. The surface of the concrete should be cross tamped to provide a key for the asphalt.

Where the ramp is inside the building, paving asphalt is laid 25mm thick direct to the concrete base but where the ramp is required to be waterproof it is necessary to provide an underlay of roofing asphalt in one coat 15mm thick (Fig 4.7).

Where warming elements are to be included in the construction these must be embedded in a layer of sand and cement and not in the asphalt. In such cases roofing asphalt in two coats to a total thickness of 20mm is first laid direct to the cross tamped concrete base. A sand and cement screed in which are embedded the warming elements, is then laid by the main contractor. This screed must also be cross tamped to form a key to receive the paving asphalt which is laid 25mm thick in one coat (Fig. 4.8).

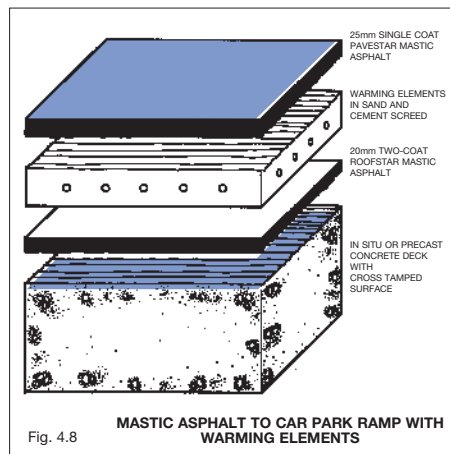
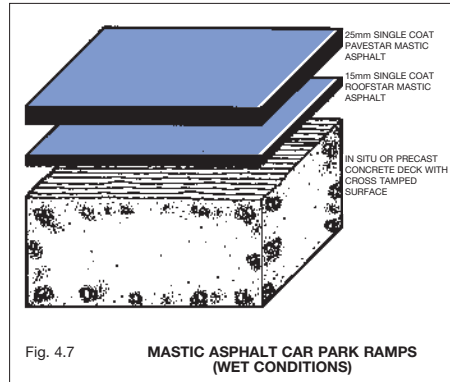

SURFACE FINISH

The paving asphalt should be well rubbed with clean sharp sand during final floating of the hot asphalt. In addition a dimpled surface may be achieved by the use of a crimping roller.

Pre-coated chippings should be rolled into the surface in heavy vehicle standing and loading areas to improve resistance to indentation, in this case the paving would not be sand rubbed. However an uneven scatter of chippings must be accepted making this finish less attractive than the alternatives.

Where the individual wheel load is likely to exceed 3 tonnes pre-coated chippings must always be specified.

For normal car park usage paving asphalt does not require protection against minor oil, petrol or grease contamination but prolonged contact may cause localised softening of the binder. Proprietary coatings are available for high risk areas or where a coloured finish is required.

Paving

DETAIL FINISHES

The mastic asphalt waterproofing is laid on glass fibre tissue with a two coat angle fillet formed between the horizontal asphalt and the 13mm two coat skirting work.

The paving grade is laid allowing for a 100mm infill of roofing grade at all abutments and a second two-coat angle fillet is formed to complete the waterproofing.

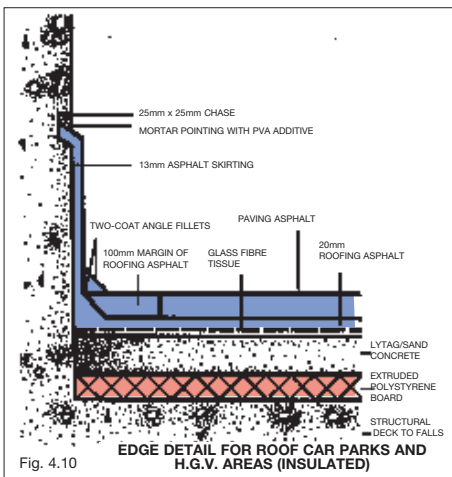
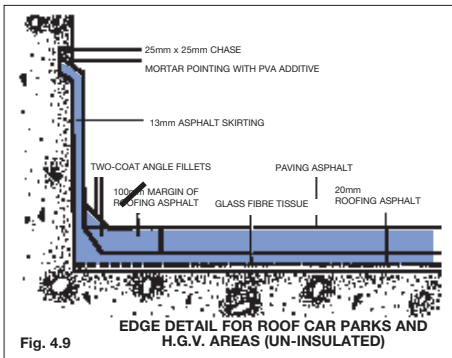

DRAINAGE DETAILS

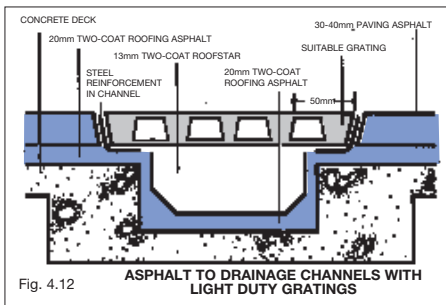
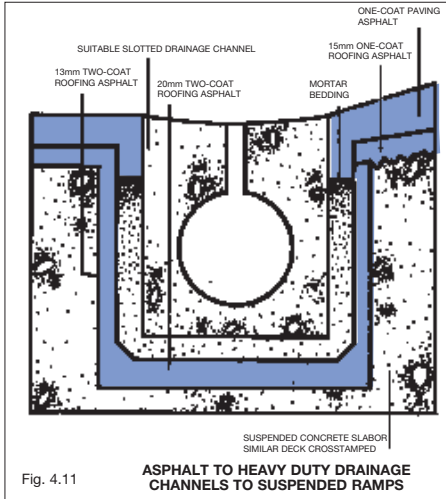

BALCONIES AND TERRACES

Refer to Roofing Section page 17.

FOOTPATHS AND PROMENADES

Normally laid at 20-30mm thickness direct to concrete on suitable base with 20%-30% of 3mm aggregate.

Surface finish is usually sand rubbed or crimped.

EXTERNAL LOADING BAYS

Pavestar H product code 4405 laid to a thickness of 40mm is normally required with 40-45% 10mm aggregate.

Edge details should be carried out as shown below.

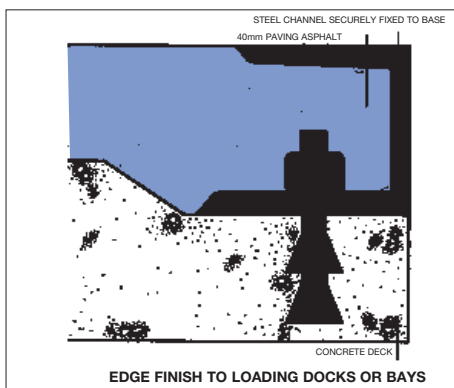

ROADS AND BRIDGES

Pavestar grades are normally specified to a nominal thickness of 38mm with 45% of 10mm aggregate.

Bridge decks are handled in a different manner from roads and usually required waterproofing. It is recommended that in both these specialist areas design assistance should be sought from Technical Services.

REPAIRS AND MAINTENANCE

Good housekeeping will ensure that gullies and gutters are kept free from leaves and debris and that damage resulting from abuse is quickly reported and repairs effected. In addition, an annual inspection should be made paying particular attention to mortar pointing and cover flashings, expansion joints, supports to crash barriers etc., and paving bay joints.

Should localised repairs be necessary they must be carried out by a specialist asphalt contractor. Prompt attention will prevent further deterioration and extend the life of the surfacing. If it is necessary to remove an area of mastic asphalt, the lines of the cuts should be covered with molten mastic asphalt until the underlying material has softened. The asphalt should not be removed until this has taken place. In no circumstances should a hammer and chisel be used to cut cold mastic asphalt. An angle grinder may, however, be used as an alternative.

Minor indentation can sometimes occur under vehicle loading during periods of high ambient temperatures but this would not be regarded as a defect and will not affect the wearing or waterproofing properties of the system.

Permanite
Asphalt Products Division

Cawdor Quarry, Matlock,
Derbyshire DE4 2JH
Telephone: 01629 582213
Facsimile: 01629 583375
Email: apd.tech@permanite.com
Internet: www.permanite.com