

WT-SYS-250-5

MATERIAL: ...

FINISH: ...

COLOR: ...

ECO	REVISION	REV DESCRIPTION	APPROVED	DATE
071607-G	A	Initial Release	GMW	7/16/2007
081407-A	B	Replace rear shield bolt with shorter one.	GMW	8/14/2007
	C	Updated Part Numbers	GMW	11/1/2007
062708-A	D	Updated Part Numbers	GMW	7/2/2008

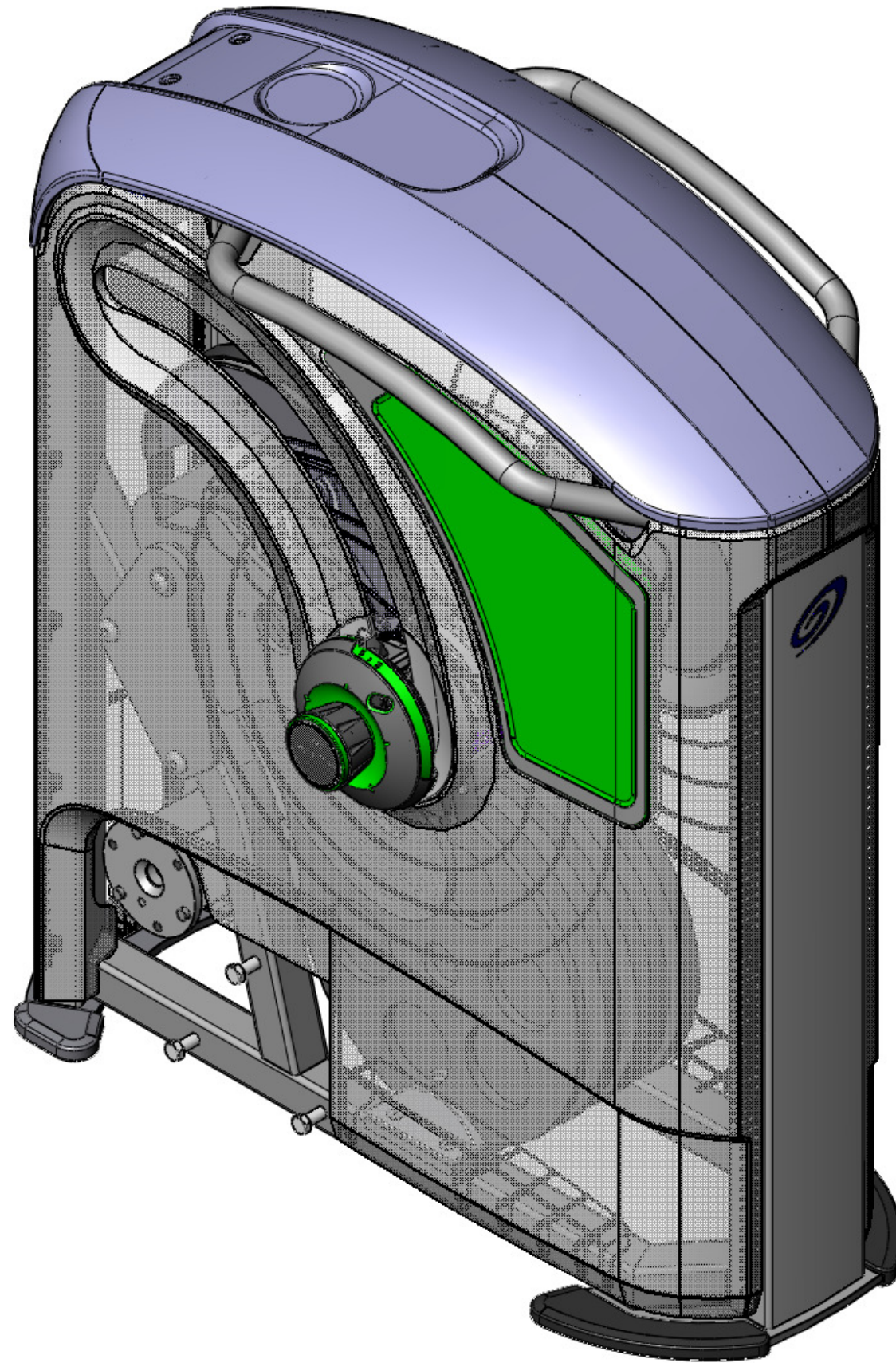

ITEM	250 Wt System with 5 lb Add-on/QTY.	PART NO.	DESCRIPTION
1	1	ENGINE-WT-250-5	ENGINE WEIGHT 250 LB 5 LB INCR
2	1	60-1202	S6 Tower Backframe
3	1	62-1211	HANDLEBAR TOWER
4	2	09-1213	Footpad Rubber Tower Front "ONE"
5	2	09-1214	Footpad Rubber Tower Rear "ONE"
6	1	01-4050	BUTTON HEAD SOCKET CAP SCREW 1/4-20 x 3/4" BRIGHT ZINC
7	2	01-4060	BUTTON HEAD SOCKET CAP SCREW 1/4-20 x 3/8" BRIGHT ZINC
8	1	KIT-TOWR-SHIELD	SHIELD KIT FOR S6 WEIGHT SYS
9	2	03-1055	1/2" Lock Nut
10	1	04-5207	WASHER, FLAT, 1/2" SAE
11	2	01-4054	BUTTON HEAD SOCKET CAP SCREW 1/2-13 x 1 1/2" BRIGHT ZINC
12	1	07-4005	Efson PF1008
13	1	01-4053	BUTTON HEAD SOCKET CAP SCREW 1/2-13 x 1" BRIGHT ZINC
14	1	67-1200	Weight Drive Tower Positive Cam
15	2	56-0035	CLAMP BELT 1 1/4"
16	1	24-6045 (49.5")	Component Belt Weight Engine "ONE" - 49.5"
17	4	01-4035	1/4-20 UNC x 1 1/4" Wiz Lock Bolt
18	1	KNOB-LB-250-5	Weight Select Knob Assy
19	1	09-5030	FOOTPAD MOLDED BLACK
20	4	01-4070	BUTTON HEAD SOCKET CAP SCREW, 5/8-11 x 1" BRIGHT ZINC
21	1	09-1273	Stop Weight Lower Engine "ONE"
22	1	56-0143	Mount Plate Inside Engine "ONE"
23	1	56-0144	Mount Plate Outside Engine "ONE"
24	1	56-0096	Mount Tower Display Marketing
25	1	03-4035	1/4-20 INSERT 11/16" LONG
26	2	02-9220	3/8-16 UNC x 1 1/4 Bolt
27	2	01-1550	3/8-16 UNC x 3 Bolt
28	4	02-3056	SCW-FHSCS 0313-18x0.625 G8-Zc
29	2	02-3054	SCW-FHSCS 0250-20x0.625 G8-Zc
30	4	03-1035	3/8" Lock Nut
31	2	03-2020	1/4" Lock Nut
32	1	09-4092	BUMPER
33	1	09-1272	Stop Weight Upper Engine "ONE"
34	1	12-5620	NLS Logo 3" Decal (001-4009)
35	1	12-5625	Engine Cover Decal "ONE"
36	1	12-1380	MADE IN USA
37	1	19-1291	SERIAL NO. DECAL
38	1	12-5626	NLS ONE Back Dome
39	1	12-5621	NLS ONE 3" Dome Decal (000-6491)
40	3	01-0011	1/2-13 UNC x 3 Bolt
41	2	56-0217	Clamp Belt ONE

NAUTILUS, INC.
16400 SE NAUTILUS DRIVE, VANCOUVER, WA 98683

UNLESS OTHERWISE SPECIFIED:
1. ALL DIMENSIONS APPLY BEFORE PLATING OR COATING.
2. REACH ALL DIMENSIONS BREAK SHARP EDGES 100 IN MAX.
3. ALL MACHINED SURFACES Ra 125 UN.
4. ALL APPLICABLE NAUTILUS STANDARDS AND SPECIFICATIONS APPLY.

INCH

THIRD ANGLE PROJECTION

TOLERANCES:
X .125
XX .020
XXX .010
X.XXX .005
XX .004
ANGULAR ±1°

DESIGNED: G. WEBB
DRAWN: G. Webb
DATE: 09/07/07

TITLE: **Tower Weight Engine "ONE" 250-5**
PART NO: **WT-SYS-250-5** REV: **D**

SCALE: 1:2 SHEET 1 OF 7

This document is the property of Nautilus, Inc. It may not be reproduced in whole or part, provided to third parties, or used for any purposes other than the performance of work for Nautilus, Inc. without written authorization. All rights are reserved, including copyrights.

WT-SYS-250-5

MATERIAL. --

FINISH. --

REVISIONS				
ZONE	REV.	DESCRIPTION	DATE	APPROVED
-	-	See Weight Tower BOM	-	-

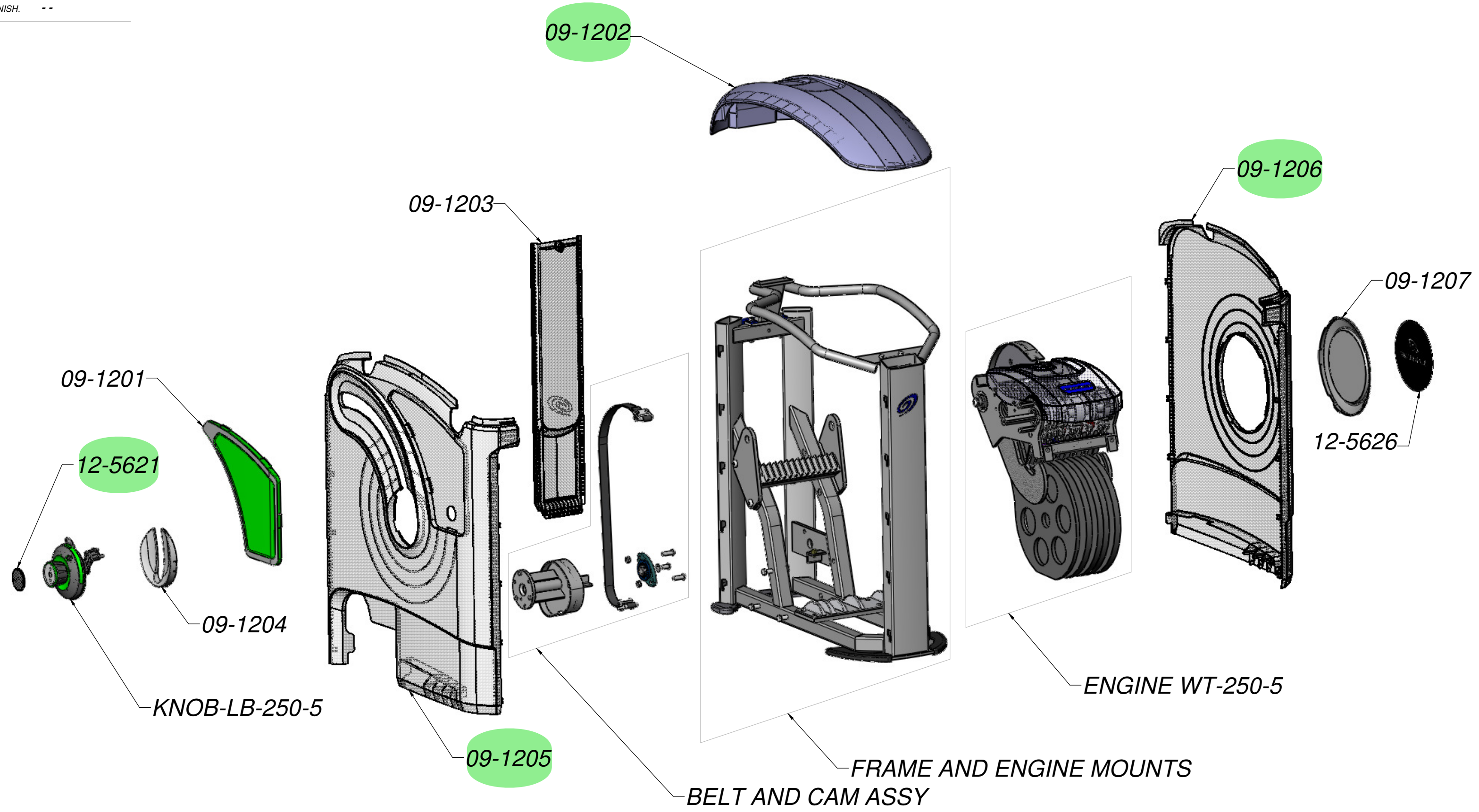

NAUTILUS, INC.
 16400 SE NAUTILUS DRIVE, VANCOUVER, WA 98683
 CONTACT email / phone #

UNLESS OTHERWISE SPECIFIED:
 1. ALL DIMENSIONS APPLY BEFORE PLATING OR COATING.
 2. REMOVE ALL BURRS, BREAK SHARP EDGES 0.5 MM MAX.
 3. ALL MACHINED SURFACES Ra 3.2 µm.
 4. ALL APPLICABLE NAUTILUS STANDARDS AND SPECIFICATIONS APPLY.

METRIC THIRD ANGLE PROJECTION

TOLERANCES.

X.	± 3
X.X	± 0.5
X.XX	± 0.25
X.XXX	± 0.1
ANGULAR	± 1°

(INTERPRET DIMENSIONS AND TOLERANCES PER ASME Y14.5M - 1994)

DESIGNED	G. WEBB
DRAWN	G. Webb
DATE	09/07/07

TITLE: **Tower Weight Engine "ONE" 250-5**

SIZE	D	PART NO.	WT-SYS-250-5	REV.	D
------	---	----------	---------------------	------	----------

SCALE: 1:6 SHEET 2 OF 7

WT-SYS-250-5

MATERIAL --
FINISH --

ZONE	REV	DESCRIPTION	REVISIONS	DATE	APPROVED
		See Weight Your BOM			

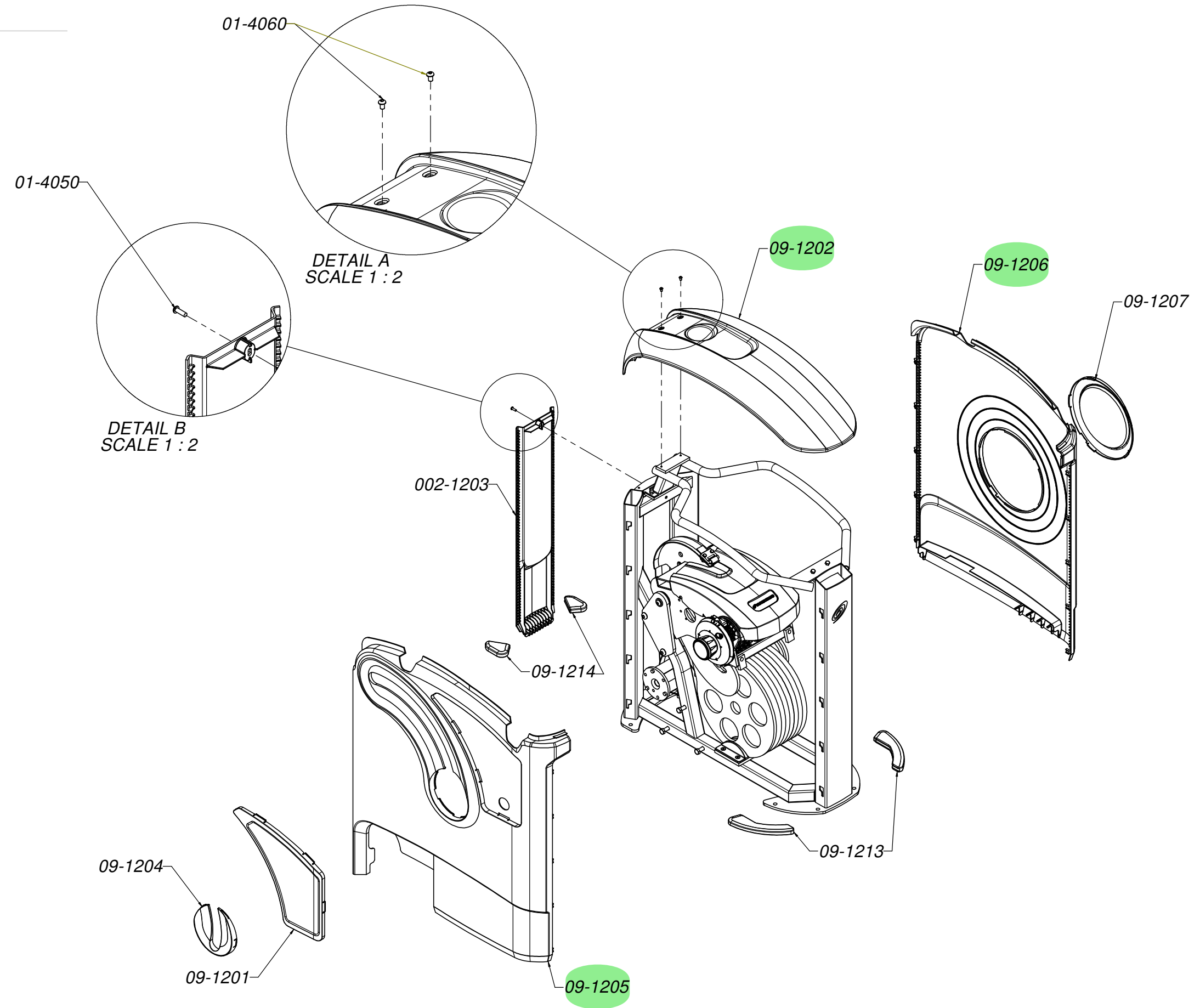

NAUTILUS
NAUTILUS, INC.
16400 SE NAUTILUS DRIVE, VANCOUVER, WA 98683
CONTACT email / phone #

UNLESS OTHERWISE SPECIFIED:
1. ALL DIMENSIONS APPLY BEFORE PLATING OR COATING.
2. FINISH: ALL BEVELS BREAK SHARP EDGES 0.5 MM MAX.
3. ALL MACHINED SURFACES Ra 3.2 UM.
4. ALL APPLICABLE NAUTILUS STANDARDS AND SPECIFICATIONS APPLY.

METRIC THIRD ANGLE PROJECTION

TOLERANCES:

X	± 3
XX	± 0.5
XXX	± 0.25
XXXX	± 0.1
ANGULAR	± 1°

(INTERPRET DIMENSIONS AND TOLERANCES PER ASME Y14.5M - 1994)

DESIGNED	G. WEBB
DRAWN	G. Webb
DATE	09/07/07

TITLE: **Tower Weight Engine "ONE" 250-5**
SIZE: **E** PART NO: **WT-SYS-250-5** REV: **D**
SCALE: 1:5 SHEET 3 OF 7

WT-SYS-250-5

MATERIAL: ..

FINISH: ..

REVISIONS				
ZONE	REV.	DESCRIPTION	DATE	APPROVED
		See Weight Tower BOM		

- ALL BOLD RED NUMBERS ARE POWDER COATED

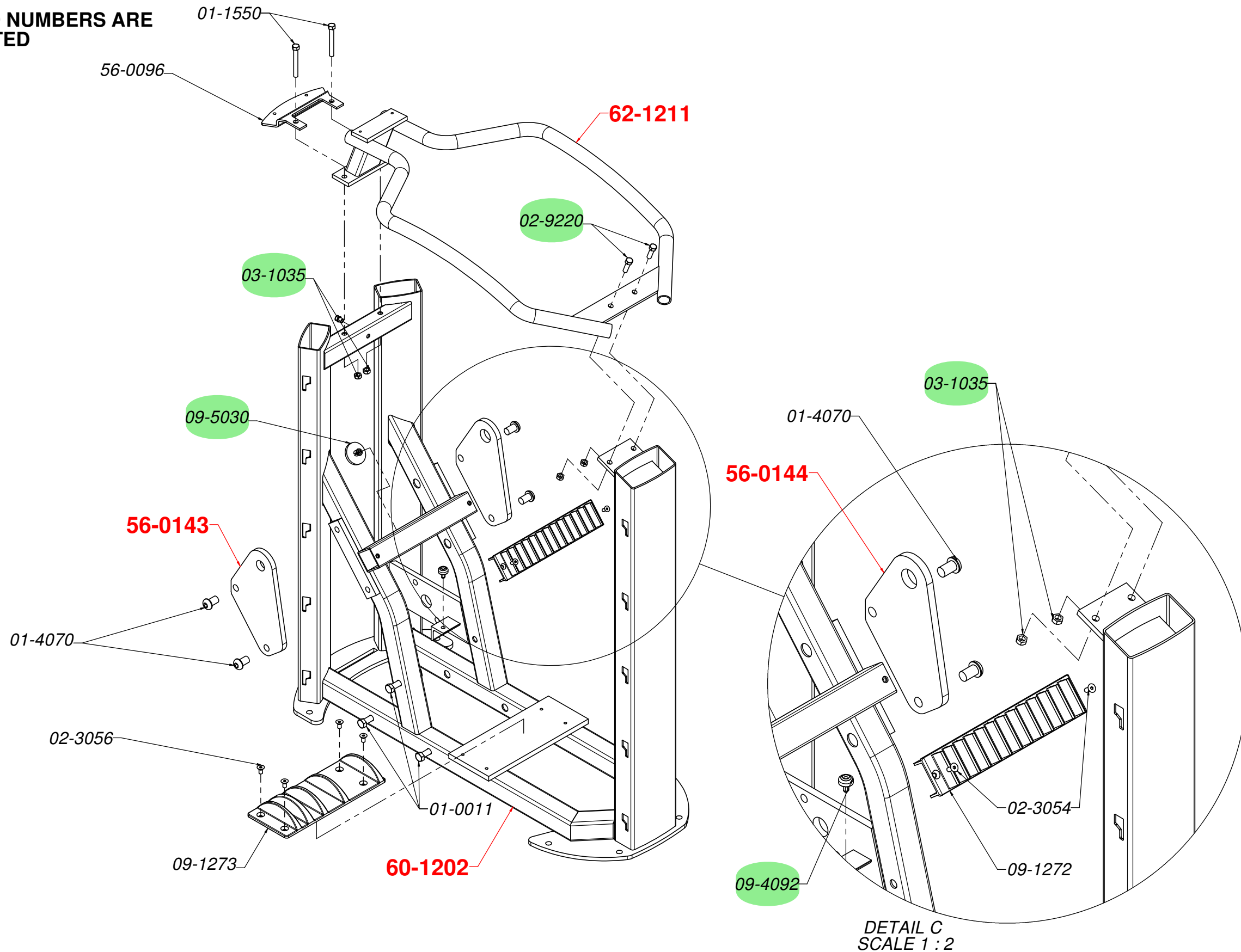

DETAIL C
SCALE 1 : 2

NAUTILUS
NAUTILUS, INC.
16400 SE NAUTILUS DRIVE, VANCOUVER, WA 98683
CONTACT: email / phone #

UNLESS OTHERWISE SPECIFIED:
1. ALL DIMENSIONS APPLY BEFORE PLATING OR COATING.
2. FINISH: ALL BEHNS BREAK SHARP EDGES 300 IN MAX.
3. ALL MACHINED SURFACES R4 125 UN.
4. ALL APPLICABLE NAUTILUS STANDARDS AND SPECIFICATIONS APPLY.

INCH

THIRD ANGLE PROJECTION

TOLERANCES:
X ±.125
XX ±.020
XXX ±.010
XXX ±.005
XXX ±.004
ANGULAR ±1°

DESIGNED: G.WEBB
DRAWN: G.Webb
DATE: 09/07/07

TITLE: Tower Weight Engine "ONE" 250-5
PART NO: WT-SYS-250-5
REV: D

SCALE: 1:3 SHEET 4 OF 7

This document is the property of Nautilus, Inc. It may not be reproduced in whole or part, provided to third parties, or used for any purposes other than the performance of work for Nautilus, Inc. without written authorization. All rights are reserved, including copyrights.

WT-SYS-250-5

MATERIAL --

FINISH --

ZONE	REV.	DESCRIPTION	DATE	APPROVED
		See Weight Tower ROM		

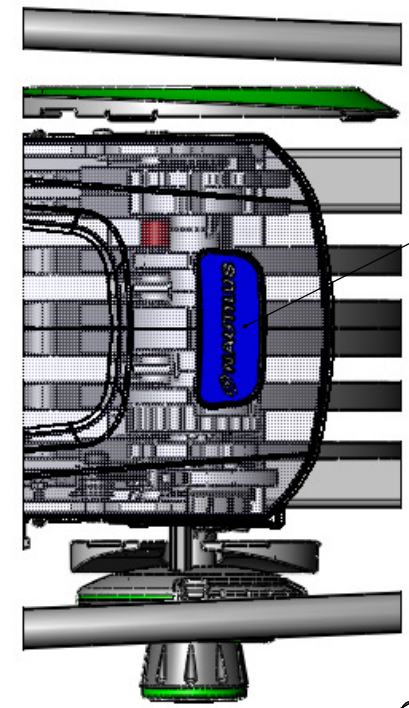
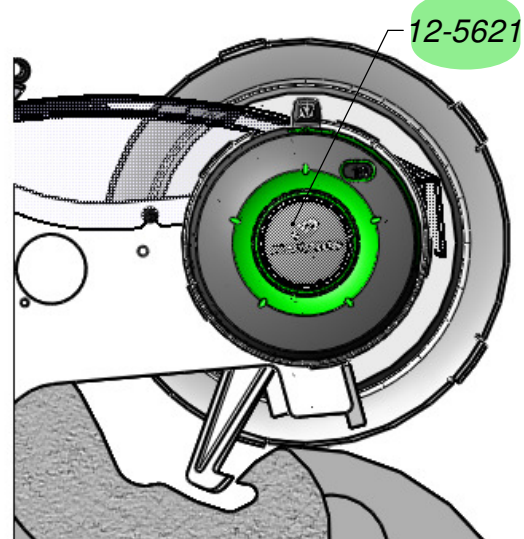
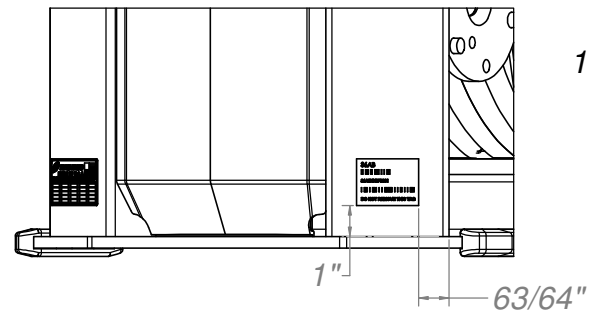
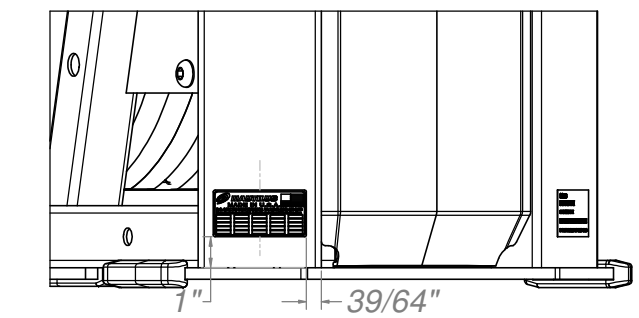

12-1380
19-1291
12-5621

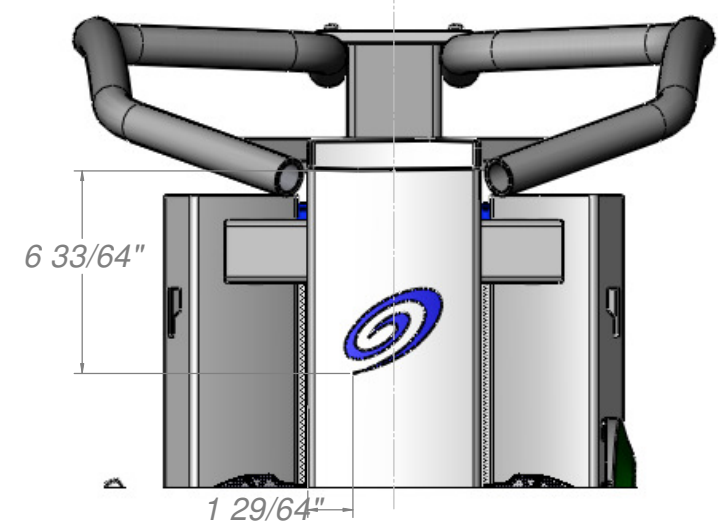
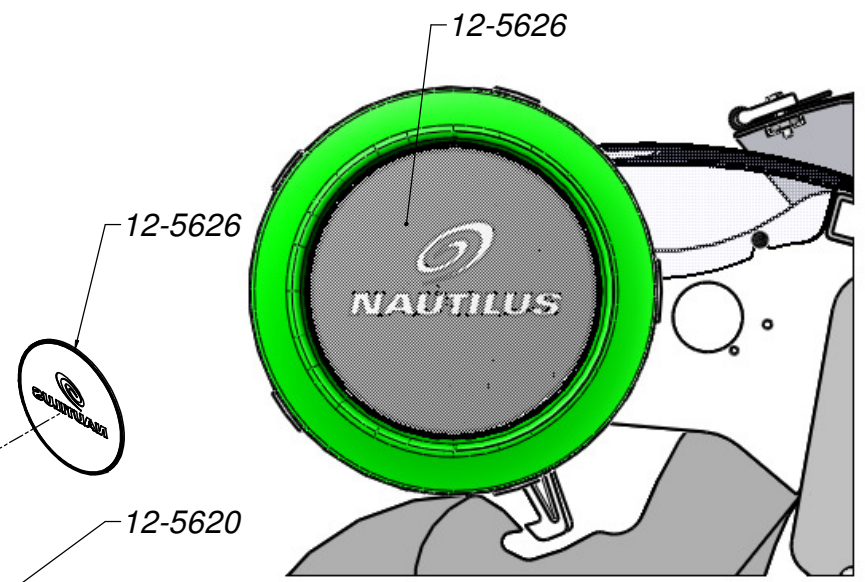
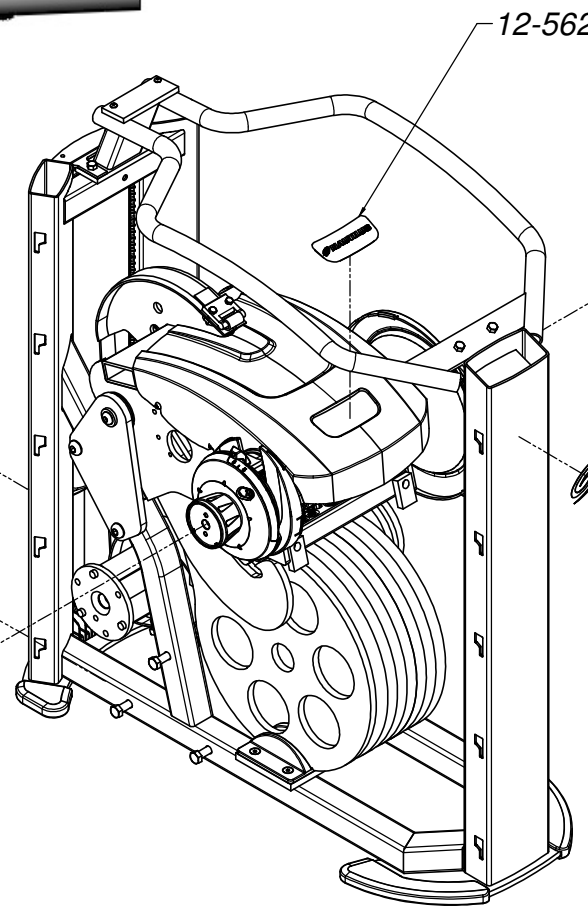

NAUTILUS
NAUTILUS, INC.
16400 SE NAUTILUS DRIVE, VANCOUVER, WA 98683
CONTACT email / phone #

UNLESS OTHERWISE SPECIFIED:
1. ALL DIMENSIONS APPLY BEFORE PLATING OR COATING.
2. REMOVE ALL BURRS; BREAK SHARP EDGES 0.5 MM MAX.
3. ALL MACHINED SURFACES Ra 3.2 UM.
4. ALL APPLICABLE NAUTILUS STANDARDS AND SPECIFICATIONS APPLY.

METRIC THIRD ANGLE PROJECTION

TOLERANCES:
X ± 3
XX ± 0.5
XXX ± 0.25
XXXX ± 0.1
ANGULAR ± 1°

DESIGNED G. WEBB
DRAWN G. Webb
DATE 09/07/07

TITLE Tower Weight Engine "ONE" 250-5
SIZE PART NO. WT-SYS-250-5
E
SCALE: 1:4 SHEET 5 OF 7

This document is the property of Nautilus, Inc. It may not be reproduced in whole or part, provided to third parties, or used for any purposes other than the performance of work for Nautilus, Inc. without written authorization. All rights are reserved, including copyrights.

WT-SYS-250-5

MATERIAL --

FINISH --

REVISIONS				
ZONE	REV.	DESCRIPTION	DATE	APPROVED
		See Weight Tower BOM		

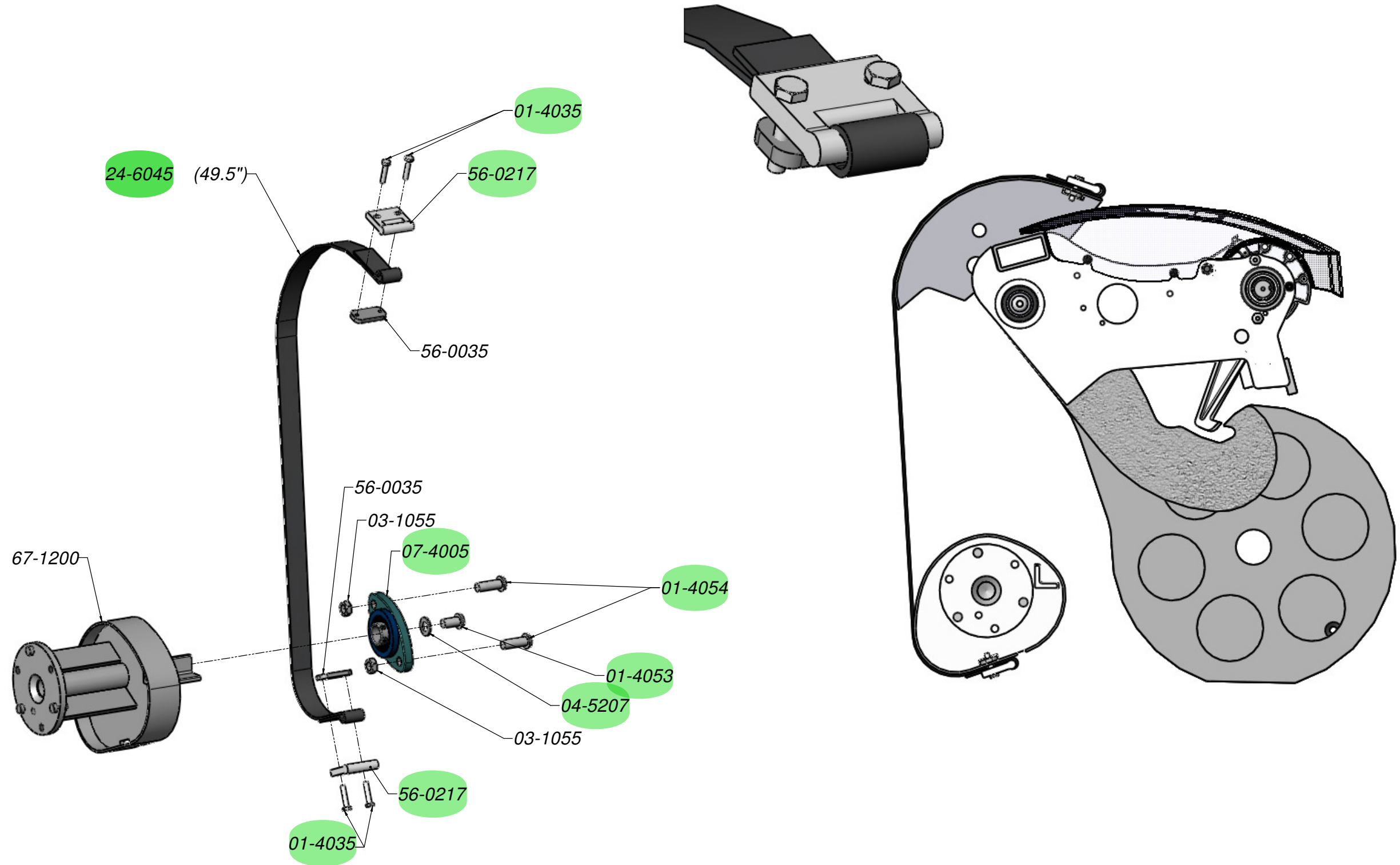

NAUTILUS
 NAUTILUS, INC.
 16400 SE NAUTILUS DRIVE, VANCOUVER, WA 98683
 CONTACT email / phone #

UNLESS OTHERWISE SPECIFIED:
 1. ALL DIMENSIONS APPLY BEFORE PLATING OR COATING.
 2. REMOVE ALL BURRS; BREAK SHARP EDGES 0.5 MM MAX.
 3. ALL MACHINED SURFACES Ra 3.2 UM.
 3. ALL APPLICABLE NAUTILUS STANDARDS AND SPECIFICATIONS APPLY.

METRIC THIRD ANGLE PROJECTION

TOLERANCES:
 X ± 3
 XX ± 0.5
 XXX ± 0.25
 XXXX ± 0.1
 ANGULAR ± 1°

DESIGNED G.WEBB
 DRAWN G.Webb
 DATE 09/07/07

TITLE Tower Weight Engine "ONE" 250-5
 SIZE PART NO WT-SYS-250-5 REV D
 SCALE: 1:2 SHEET 6 OF 7

This document is the property of Nautilus, Inc. It may not be reproduced in whole or part, provided to third parties, or used for any purposes other than the performance of work for Nautilus, Inc. without written authorization. All rights are reserved, including copyrights.

WT-SYS-250-5

MATERIAL --

FINISH --

REVISIONS				
ZONE	REV.	DESCRIPTION	DATE	APPROVED
-	-	See Weight Tower BOM	-	-

