

# MATHEMATICAL MODELLING OF TWO TANK SYSTEM

<sup>1</sup> KHELE SWARADA, ELECTRICAL, AISSMS IOIT, MAHARASHTRA, INDIA

<sup>2</sup> AARTI WALVEKAR, ELECTRICAL, AISSMS IOIT, MAHARASHTRA, INDIA

<sup>3</sup> AMITA THORAT, ELECTRICAL, AISSMS IOIT, MAHARASHTRA, INDIA

<sup>4</sup> MR S.K.MAHINDRAKAR, ELECTRICAL, AISSMS IOIT, MAHARASHTRA, INDIA

## ABSTRACT

Nowadays maintenance and controlling of liquid flow rate is been considered a vital issue. Taking into consideration this problem, coupled tank system is preferred to solve these issue. Analyzing this problem mathematical modeling of this system is been considered so that its parametric measures are taken for determination of its transfer function. Our main objective of present work is to maintain level of water at the desired set point value.

**Keyword :** (RESISTANCE), (capacitance),

## 1. INTRODUCTION

Maintaining constant liquid level is the main strategy of the two tank system. For determining the liquid level various factors are considered such as height of the tank ,area of tank, resistance of the liquid level, capacitance of the liquid level, flow rate of the liquid. First we need to calculate its individual parameters so that it becomes easy to obtain the transfer function.

The entire process of system from input and output consists of, First its suitable model structure is selected, then parameters of the model are estimated and finally the model is validated using experimental data

### 1.1 Working Principle of Two Tank System

The two tank system consist of pump, control valve , process tank , supply tank, rotameter, main power, supply switch, pump switch. The fluid level or liquid level in tank is measured by scale. The rotameter measures , the flow through the pipe and control valve's control the liquid flow.

First implement an algorithm in Matlab software. Its working principle is same as the model of two tank system and its properties are also identical and observing its response we come to know its appropriate measurement in an interacting tank system the two tanks are connected in series, the output of first tank is connected to the input of the second tank. The height of the tank is dependent on the control valve which is connected in middle between the two tanks. The liquid level flow depends on the adjustment of the control valve and its flow rate in tank 2.The height variation depends on the flow rate and control valve and thus its response is calculated.

Steps for performing experiments-

- 1) Construct the interacting two tank system as shown in figure.
- 2) Switch on the power supply of motor.
- 3) Give a constant input liquid flow(in lph) to the tank1, then open the second valve and adjust the constant reading.
- 4) Open the third valve and keep the same constant reading throughout.
- 5) Observe the level of the tank till it comes to its steady state. This is called initial state of system.

**1.2 Analysis of liquid level systems:**

Resistance and capacitance are the two important terms used in two tank system. Resistance of the liquid level is defined as change in the level difference between the two tanks which necessarily causes a unit change in flow rate.

$$R = \frac{\text{change in level difference}}{\text{change in flow rate}}$$

Capacitance of the liquid level is defined as change in quantity of stored liquid to cause a unit change in the potential head. The energy level of the system indicates the potential of the liquid level system.

$$C = \frac{\text{change in liquid stored, m}^3}{\text{change in head, m}}$$

Before explaining the modelling of two tank system we will go through a single tank system

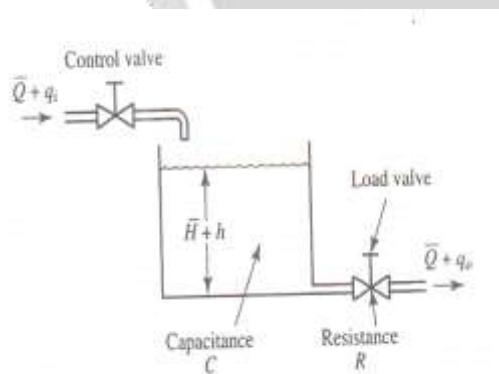

For the laminar flow if For laminar flow, the resistance *RI* is obtained as

$$R_1 = \frac{dH}{dq} = \frac{H}{Q}$$

The laminar-flow resistance is constant as it is said to be a linear flow. The nonlinear flow is the turbulent flow whose equation is represented as:

$$Q = K\sqrt{H} \dots\dots\dots 1)$$

Where,  $Q$  = steady-state liquid flow rate,  $m^3/sec$ .  $K$  = coefficient,  $m^3/sec$

$H$  = steady-state head, m .The resistance  $R$ , for turbulent flow is obtained from

$R_t = \frac{dH}{dQ}$  Since from equation 1)we have obtained

$$dQ = \frac{K}{2\sqrt{H}} dH$$

$$\frac{dH}{dQ} = \frac{2\sqrt{H}}{K} = \frac{2H}{Q}$$

$$R_t = \frac{2H}{Q}$$

The value of the turbulent-flow resistance  $R$ , depends on the flow rate and the head. The value of  $R$ , however, may be considered constant if the changes in head and flow rate are small. By use of the turbulent-flow resistance, the relationship between  $Q$  and  $H$  can be given by,

$$Q = \frac{2H}{R_t}$$

Such linearization is valid, provided that changes in the head and flow rate from their respective steady-state values are small

## 2.LIQUID LEVEL SYSTEM:

Consider the system shown in Figure(a) The variables are defined as follows:

$\bar{Q}$  = steady-state flow rate (before any change has occurred),  $m^3/sec$

$q_i$  = small deviation of inflow rate from its steady-state value,  $m^3/sec$ ,

$q_o$  = small deviation of outflow rate from its steady-state value,  $m^3/sec$

$\bar{H}$  = steady-state head (before any change has occurred), m

$h$  = small deviation of head from its steady-state value, m.

The differential equation of the system based on the assumptions that the system is either linear or linearized is as follows,

$$Cdh = (q_i - q_o)dt \quad \dots(10)$$

As the inflow minus outflow during small time interval  $dt$  is equal to the additional amount stored in tank

From the definition of resistance,

$$q_o = \frac{h}{R} \quad \dots(11)$$

The differential equation for this system for a constant value of  $R$  becomes

$$RC \frac{dh}{dt} + h = Rq_i \quad \dots(12)$$

RC is the time constant of the system.

Taking the Laplace transforms of both sides of Equation (12), assuming the zero initial condition, we obtain

$$(RCs+1)H(s)=RQ_i(s) \quad \dots(13)$$

Where

$$H(s)=L(H) \quad \text{and} \quad Q_i(s)=L(q_i)$$

If  $q_i$  is considered the input and  $h$  the output, the transfer function of the system is

$$\frac{H(s)}{Q_i(s)} = \frac{R}{RCs+1}$$

If, however,  $g_o$  is taken as the output, the input being the same, then the transfer function is

$$\frac{Q_o(s)}{Q_i(s)} = \frac{1}{RCs+1}$$

### 3. TRANSFER FUNCTION OF TWO TANK SYSTEM:

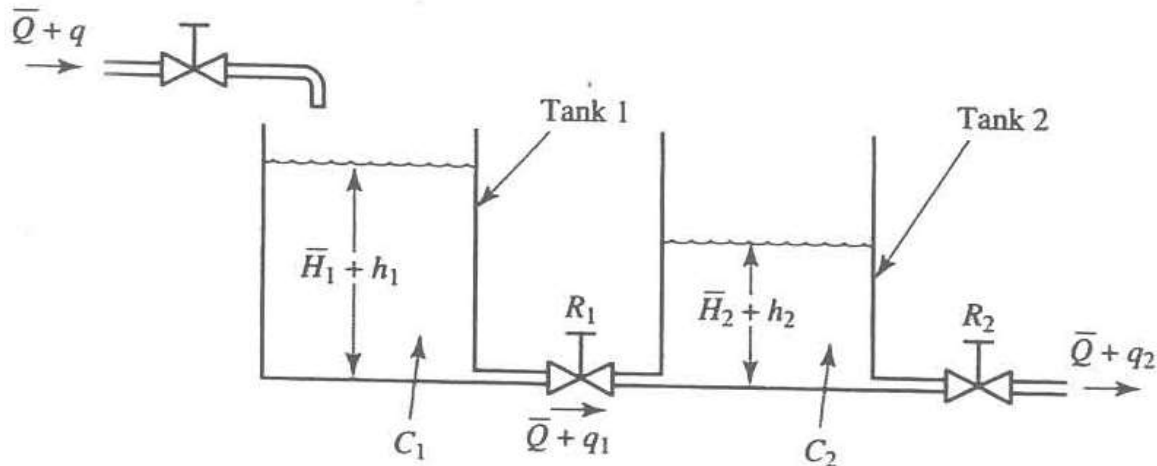

Figure(b): two tank system

Consider the system shown in Figure(b). In this system, the two tanks interact. Thus the transfer function of the system is not the product of two first-order transfer functions. In the following, we shall assume only small variations of the variables from the steady-state values. Using the symbols as defined in Figure (b) we can obtain the following equations for this system

For Tank 1

$$C_1 \frac{dh_1}{dt} = (q - q_1) \quad \dots(14)$$

Assume linear resistance to flow,

$$q_1 = \frac{h_1 - h_2}{R_1}$$

$$C_1 \frac{dh_1}{dt} = q - \frac{h_1 - h_2}{R_1}$$

$$C_1 R_1 \frac{dh_1}{dt} = R_1 q - h_1 + h_2$$

Time constant  $T_1 = C_1 R_1$

$$T_1 \frac{dh_1}{dt} + h_1 - h_2 = R_1 q$$

Taking Laplace transform on both sides of equation

$$T_1 h_1(s) + h_1(s) - h_2(s) = R_1 q(s)$$

$$h_1(s) = \frac{R_1 q(s)}{T_1 s + 1}$$

For Tank 2

$$C_2 \frac{dh_2}{dt} = q_1 - q_2$$

Assume linear resistance to flow

$$q_2 = \frac{h_2}{R_2}$$

$$C_2 \frac{dh_2}{dt} = \frac{h_1 - h_2}{R_1} - \frac{h_2}{R_2}$$

$$R_1 R_2 C_2 \frac{dh_2}{dt} = (h_1 - h_2) R_2 - h_2 R_1$$

Time constant  $T_2 = C_2 R_2$

$$T_2 R_1 \frac{dh_2}{dt} + h_2 R_2 + h_2 R_1 = h_1 R_1$$

Taking laplace transform on both sides

$$R_1 T_2 h_2(s) + h_2(s) R_2 + h_2(s) R_2 = h_1(s) R_2$$

$$(R_1 T_2 s + R_2 + R_1) h_2(s) = h_1(s) R_2$$

In equation () putting value of equation ()

$$((R_1T_2s + R_2 + R_1)h_2(s) = \frac{R_1R_2q(s)}{T_1s+1} + \frac{R_2h_2(s)}{T_1s+1}$$

Solving above equation

$$R_1(T_1s + 1)(T_2s + 1) + R_2(T_1s + 1)h_2(s) - R_2h_2(s) = R_1R_2q(s)$$

$$(T_1T_2s^2 + s(T_1 + T_2 + C_1R_2) + 1) = R_2$$

Convert above equation in form of  $\frac{h_2(s)}{q(s)}$

$$\frac{h_2(s)}{q(s)} = \frac{R_2}{T_1T_2s^2 + s(T_1 + T_2 + C_1R_2) + 1}$$

#### 4.SIMULATION :

By manipulating the values mathematically and for obtaining

Its response without computer assistance it becomes quite tedious so MATLAB is a valuable tool for solving such complex calculations .It become more convenient to simulate the two tanks liquid level controlling system .They are to be performed step by step and according to it results are obtained .The transfer function is obtained by doing analysis and thus results are been verified by simulation.

Experimental result taken from real time system

Flow in lph	Height in tank 1(cm)	Height in tank 2(cm)	Time (min.)
100	13.2	8.6	6.8
160	20.5	13.5	13.13

#### 4.1.Calculation-

Circumference of tank-

$$2\pi r=97.5$$

$$r=\frac{97.5}{2\pi}=15.51\text{cm} , h=32\text{cm}$$

$$A=\pi r^2 =\pi(15.51)*(15.51)10^{-4}$$

$$=0.0755\text{m}^2$$

$$R_1 = \frac{20.5-13.2}{160-100} = \frac{7.3\text{cm}}{60\text{lph}} = \frac{0.073\text{m}}{0.01667\text{m}^3/\text{sec}} = 4.379\text{sec}/\text{m}^2$$

$$R_2 = \frac{13.5-8.6}{160-100} = \frac{4.9\text{cm}}{60\text{lph}} = \frac{0.049\text{m}}{0.01667\text{m}^3/\text{sec}} = 2.939 \text{ sec/m}^2$$

**4.2.Open loop model for interacting tank:**

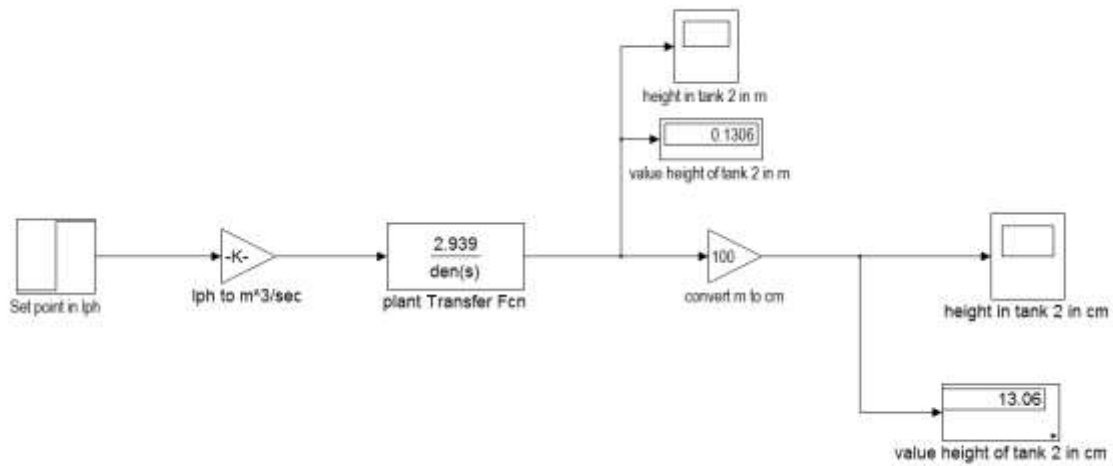

**4.3.Simulation result of open loop model:**

X-axis time in sec

Y-axis output in mm

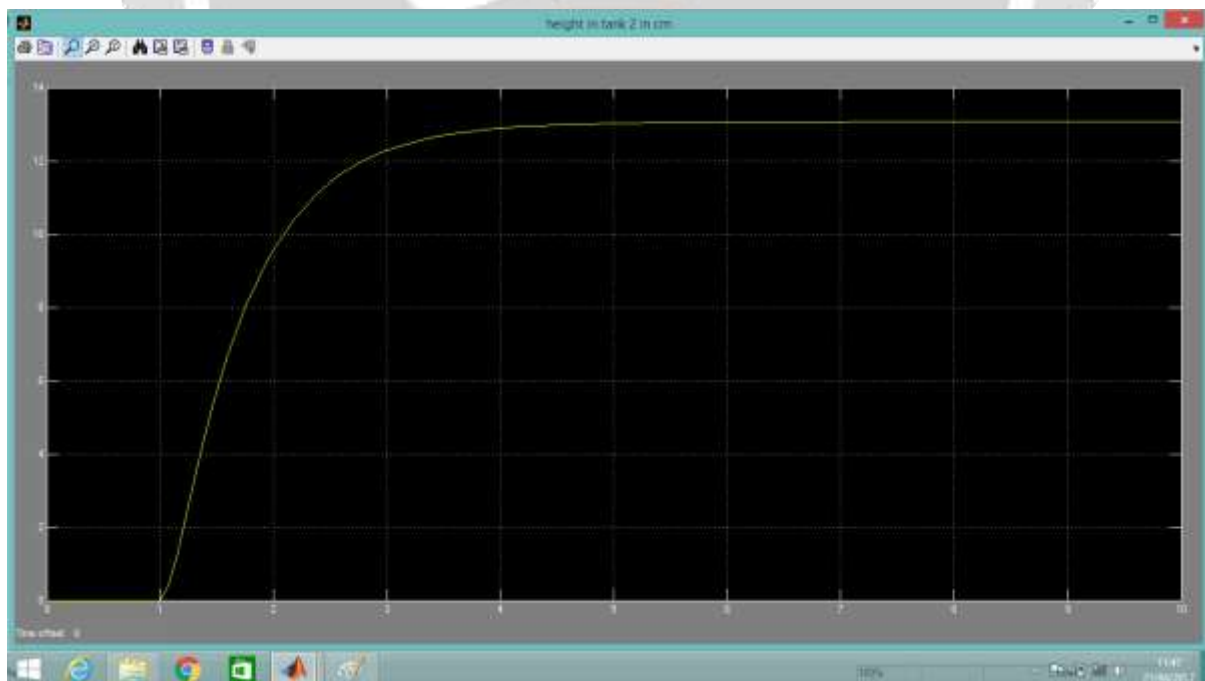

**5.CONCLUSION:**

Two tank system was mathematically modelled and its transfer function was found . The transfer function was tested using the step response considering various factors such as height of tank , area , resistance, and

capacitance of liquid and flow rate. In this paper the trial and error method was used to find the best performance by changing valve position .

#### 6. REFERENCES:

- 1.. Designing a Controller for Two Tank Interacting System **Miral Changela1, Ankit Kumar2** Department of Instrumentation and Control, Atmiya Institute of Technology and Science, Rajkot, India.
2. **Design of Tuned PID Controller for 2-Tank System** Sabah Abd Elmonem1, Muawia Mohamed Ahmed Mahmoud2 P.G. Student, Department of Control Engineering, AL Neelain University, Faculty of Engineering, KH, Sudan1 Associate Professor, Department of Control Engineering, AL Neelain University, Faculty of Engineering, KH, Sudan2.
3. **SYSTEM IDENTIFICATION AND MODELING FOR INTERACTING AND NON-INTERACTING TANK SYSTEMS USING INTELLIGENT TECHNIQUES** Bhuvaneswari N S1, Praveena R2, Divya R3 Electronics and Instrumentation Engineering Department, Easwari Engineering College, Chennai, Tamilnadu, India.
4. **Mathematical Modeling of Interacting and Non Interacting Tank System** **Mr. Parvat. B.J.1, Mr. Deo.S.A.2 and Mr.KaduC.B.3.**
5. L.ThillaiRani, N.Deepa, S.Arulselvi, “ Modeling and Intelligent Control Of two tank Interacting Level Process”, International Journal of Recent Technology and Engineering (IJRTE) ,ISSN: 2277-3878, Volume-3, Issue-1, March 2014 .

