

Maths Module 8

Trigonometry

This module covers concepts such as:

- measuring angles: radians and degrees
- Pythagoras' theorem
- sine, cosine and tangent
- cosecant, secant, cotangent

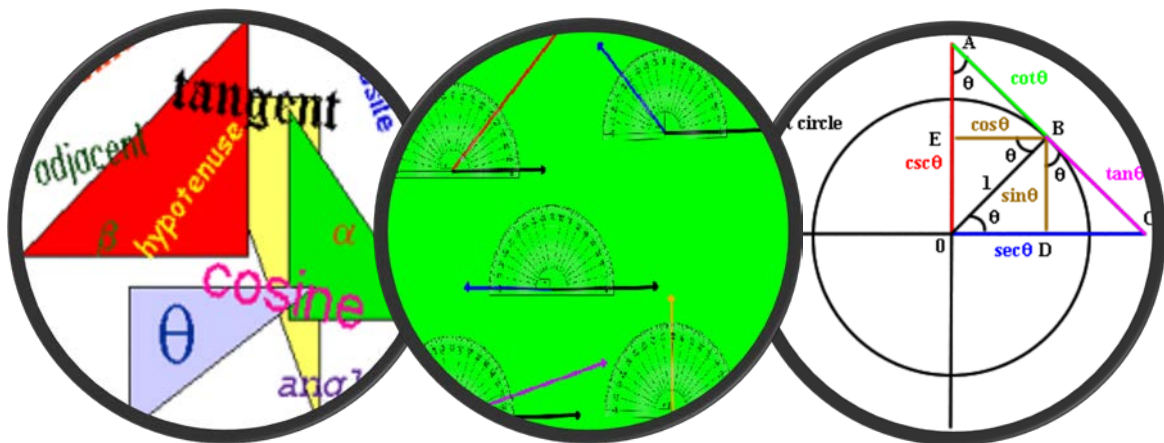

www.jcu.edu.au/students/learning-centre



The Learning Centre
UNLOCK YOUR POTENTIAL

Module 8

Trigonometry

This module will cover the following concepts:

1. Introduction to Trigonometry
2. Measuring Angles: Radians and Degrees
3. Right Angle Triangles and the Pythagorean Theorem
4. Equation of a Circle
5. Trigonometric Functions: Sine, Cosine and Tangent
6. Applying Trigonometric Functions: Word Problems
7. Reciprocal Trigonometric Functions: Cosecant, Secant and Cotangent
8. Answers
9. Helpful Websites

1. Introduction to Trigonometry

Trigonometry is the study of the properties of triangles, as the word suggests. Considering that all polygons can be divided into triangles, understanding properties of triangles is important. Trigonometry has applications for engineers, builders, architects and surveyors.

To begin we will explore the angle sum of polygons. In module seven we established that the angle sum of a triangle is 180° and the angle sum of a quadrilateral is 360° , two times that of a triangle. This reasoning applies because a quadrilateral can be divided into two triangles, as right:

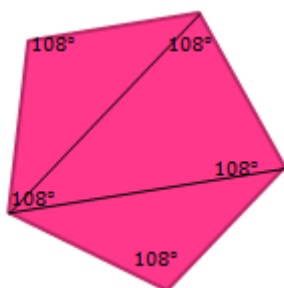
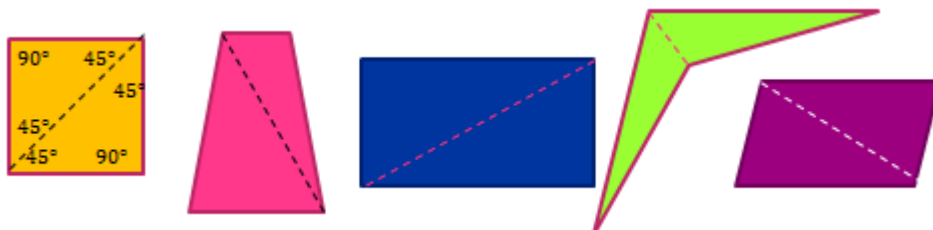

Hence, knowing that the angle sum of a triangle is 180° , and that polygons can be divided into triangles, we can use this knowledge to calculate the angle sum of polygons and then the individual angles of regular polygons. For example, a pentagon can be divided into 3 triangles: each triangle having a total angle sum of 180° , so the total angle sum of the pentagon angles is $3 \times 180^\circ = 540^\circ$. If the pentagon was a 'regular pentagon,' then each of the interior angles could be calculated by dividing the angle sum by the number of angles, in this case there are (5) $\therefore 540 \div 5 = 108^\circ$

The **general rule** is that each time we add another side to a shape, we add another 180° .

Let's look at a regular octagon. It has eight sides of equal length and eight interior angles the same. If the shape was cut into triangles, then we could calculate the total sum of the eight angles. Please note that the lines must not cross. We count the triangles and then multiply the total by 180° . Hence, there are six triangles: $6 \times 180 = 1080 \therefore$ the angle sum of an octagon is 1080° .

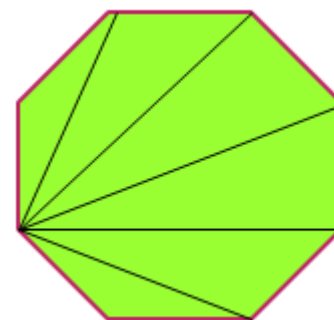

Because this is a regular octagon we can now work out the size of each interior angle: $1080 \div 8 = 135$

\therefore the angles of a regular octagon are 135°

So we can see that we have eight sides and six triangles, for the pentagon we had five sides and three triangles and for the quadrilateral we had four sides and two triangles. Can you identify a pattern?

'The number of triangles is two less than the number of sides of the polygon.'

Another general rule:

The formula to calculate the angle sum of a polygon is:

$180(n - 2) = \text{angle sum}$, where $n = \text{number of sides}$, and $\frac{180(n-2)}{n} = \text{each angle of a regular polygon}$

1. Your Turn:

Draw two hexagons, one that is regular and one that is irregular.

Divide both into triangles.

- How many triangles are there in each one?
- What is the angle sum of the hexagons?
- What is the size of the individual angles on the 'regular hexagon'?

Congruence

This section covers the term congruence. If two plane shapes can be placed on top of each other exactly, then they are **congruent**. The corresponding **angles**, for example, $\angle BAC$ and $\angle DFE$ (g and m) are the same, and the **intervals**, for instance, AB and FE of each shape match perfectly. In addition, the perimeter and the area will be identical, thus the perimeter and area of $\triangle ABC$ is identical to the perimeter and area of $\triangle DEF$. Also, the vertices and sides will match exactly for $\triangle ABC$ & $\triangle DEF$.

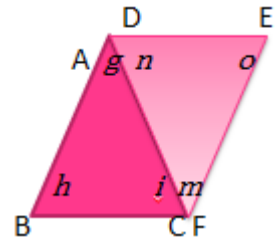

In summary: $g = m$; $h = o$; $i = n$

$$AB = EF; \quad BC = ED; \quad AC = FD$$

The mathematical symbol for congruence is " \cong ". Therefore, $\triangle ABC \cong \triangle DEF$

Many geometric principles involve ideas about congruent triangles. There are four standard tests of congruency that will be explored below.

SSS: Side, Side, Side: the three sides of one triangle are equivalent to the three sides of the other triangle.

SAS: Side, Angle, Side: an angle and the related two sides are equal to that of the corresponding sides and angle of the other triangle.

AAS: Angle, Angle, Side: two angles and the related side are identical to the corresponding two angles and side of the other triangle.

RHS: Right angle, Hypotenuse, Side: The hypotenuse and one side of a right angle triangle are identical to the corresponding hypotenuse and side of the other right angle triangle.

Similar

If a shape looks that same but is a different size it is said to be **similar**. The corresponding angles in shapes that are similar will be **congruent**. The ratios of adjacent sides in the corresponding angle will be the same for the ratio of adjacent sides in a similar triangle. For example: the ratio $AB:BC$ is as $EF:ED$.

The angles are the same: $g = m$; $h = o$; $i = n$

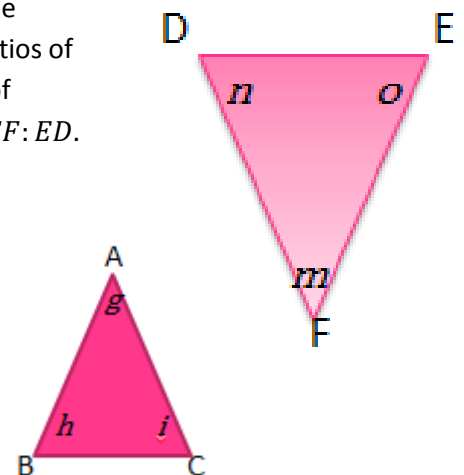

2. Measuring Angles: Radians and Degrees

This section is an introduction into angle measurement. Angles are often measured in two ways, degrees and radians. In module seven, we looked at how an angle is measured by the amount of turn of a line. The amount of turn relates to the circle, where a full revolution is 360° . Hence, 1 **degree** (1°) is $\frac{1}{360}$ th of a full revolution. If we take a line section AB , and rotate it half a revolution ($\frac{180^\circ}{360^\circ}$) to the position of AC , then we get a straight angle as shown.

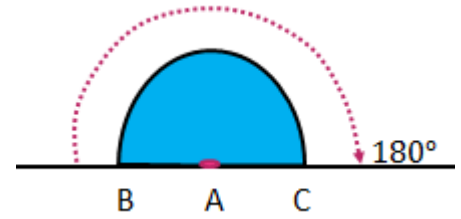

A **radian**, which is short for **radius angle**, is also based on the concept of a circle. If the arc length of a sector is equal to the radius, then we can say that the angle is 1 radian. If the angle is in degrees, we must use the correct symbol $'^\circ'$ to show that the angle has been measured in degrees. Otherwise it is assumed that the angle is measured in radians. Often radian is abbreviated, so 1 radian will be abbreviated to 1.

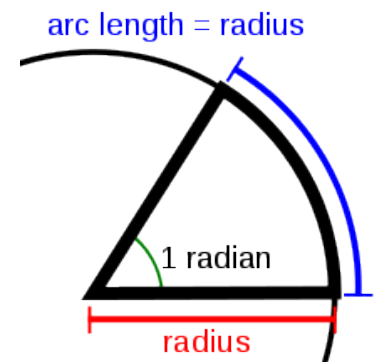

The images below show that an arc length of $1r$ is opposite to (subtends) an angle of 1 radian. Then in the next image we can see that an arc length of $3r$ is opposite to an angle of 3 radians.

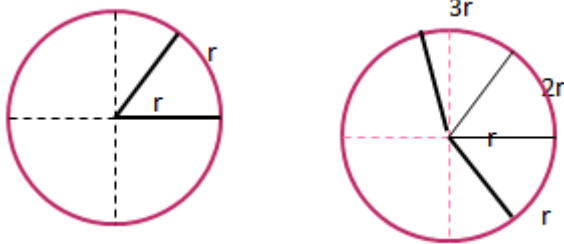

Thus if we think about the circumference of a circle as $C = 2\pi r$, we could say that an arc of $2\pi r$ subtends the angle of 2π . In other words, the circumference of a circle subtends a full revolution. This then implies that $2\pi = 360^\circ \therefore \pi = 180^\circ$.

EXAMPLE PROBLEMS:

Convert to radians:

1. Convert 30° into radians

$$180^\circ = \pi \text{ and thus } 1^\circ = \frac{\pi}{180}$$

$$30^\circ = 30^\circ \times \frac{\pi}{180^\circ}$$

$$\therefore 30^\circ = \frac{\pi}{6} \approx (0.52)$$

2. Convert 90° into radians

$$90^\circ = 90 \times \frac{\pi}{180}$$

$$\therefore 90^\circ = \frac{\pi}{2} \approx (1.57)$$

Convert to degrees:

1. Convert 1 radian to degrees

$$\text{So } \pi = 180^\circ$$

$$1 = \frac{180^\circ}{\pi} \approx 57^\circ$$

$$\therefore 1 \text{ radian} \approx 57^\circ$$

2. Convert 3 radian to degrees

$$3 = 3 \times \frac{180}{\pi} \approx 172^\circ$$

$$\therefore 3 \text{ radian} \approx 172^\circ$$

Note: to convert radian to degrees we can apply the formula: $1 \text{ Radian} = \frac{180^\circ}{\pi} \approx 57^\circ$

2. Your Turn:

a. Convert to 72° into radians

b. Convert 0.7π in degrees

3. Right Angle Triangles and the Pythagorean Theorem

To begin, we can identify the parts of a right angled triangle:

- The right angle is symbolised by a **square**.
- The side directly opposite the right angle is called the **hypotenuse**. The hypotenuse **only** exists for right angle triangles.
- The hypotenuse is always the longest side.
- If we focus on the angle $\angle BAC$, the side opposite is called the **opposite** side.
- The side touching angle $\angle BAC$ is called the **adjacent** side.

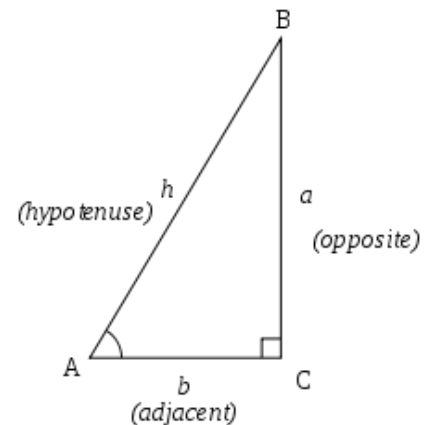

Investigating right angle triangles

What sorts of things could you say about this image, mathematically speaking?

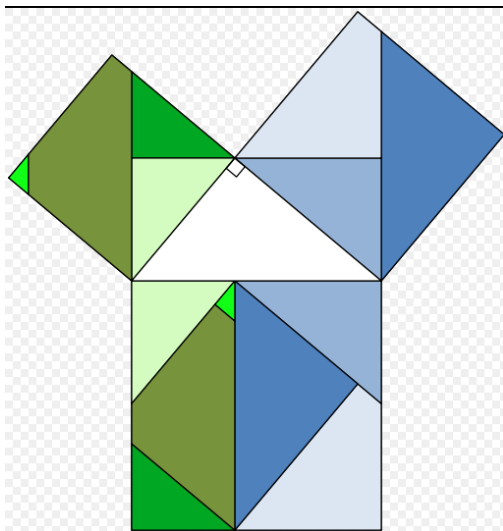

- * There is a right angle triangle in the centre.
- * It is surrounded by three squares –
- * Is there a relationship between the squares?
- * ...
- * ...
- * ...

Image accessed

from: http://en.wikipedia.org/wiki/Pythagorean_theorem#mediaviewer/File:Pythagorean_theorem_rearrangement.svg

Let's explore further and come back to this image later...

The **hypotenuse** is related to a Greek word that means to stretch. What do you do if you were to make a right angle and you did not have many measuring instruments? One way is to take a rope, mark off three units, turn; then four units, turn; and then five units. Join at the beginning and when stretched out, you should have a triangle. The triangle created will form a right angle, as right.

The relationship between these numbers, 3, 4 and 5 were investigated further by Greek mathematicians and are now commonly known now as a Pythagorean triple. Another triple is 5, 12 and 13. You might recall the mathematical formula: $a^2 + b^2 = c^2$. This is one of the rules of trigonometry; the Pythagoras theorem which states:

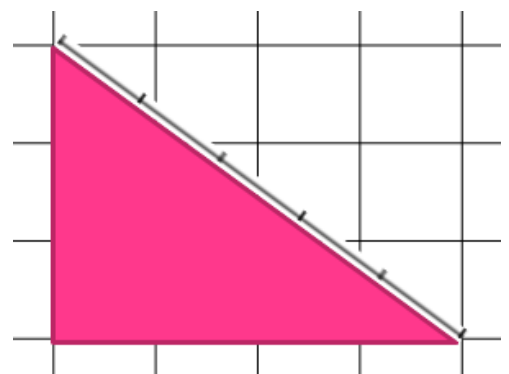

“The square of the hypotenuse is equal to the sum of the square of the other two sides”

Pythagoras was a Greek mathematician who proved the Pythagorean Theorem. Apparently there are now 400 different proofs of the theory, according to the *Math Open Reference* website (for more information go to <http://www.mathopenref.com/pythagoras.html>).

Let's return to the coloured image above. If we were to cut out the squares, then you will notice that the square off the hypotenuse covers the same area as the other two combined. (Copy it and cut it out to prove it to yourself, there is one prepared for you on the last page.)

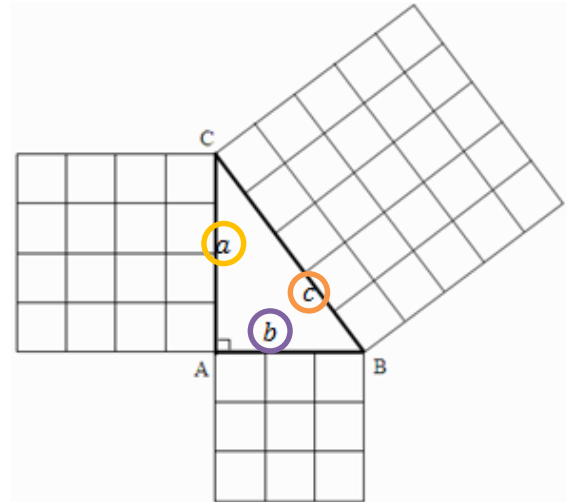

To elaborate, look at the image right. The hypotenuse is marked c . Thus if the theory $a^2 + b^2 = c^2$ is applied, the square of c should be the same as the square of a and b added together...

There are 16 squares off the side of a and there are 9 squares off the side of b .

Thus $16 + 9 = 25$ and we can see that there are 25 squares off the hypotenuse c .

This image also relates to the Pythagorean triple example above where we have three sides of units, 3, 4 & 5. You will also notice that it relates to the image on the front cover of the module.

EXAMPLE PROBLEMS:

1. Calculate the length of the unknown side.

Step 1: Recognise the hypotenuse is the unknown c .

Step 2: Write the formula: $c^2 = a^2 + b^2$

Step 3: Sub in the numbers $c^2 = 5^2 + 12^2$

$$c^2 = 25 + 144$$

$$c^2 = 169$$

$$c = \sqrt{169} \text{ (The opposite of square is root)}$$

$$c = 13$$

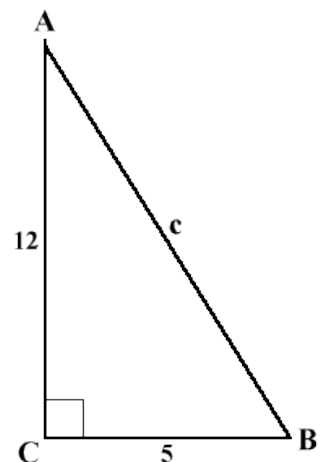

2. Calculate the length of the unknown side.

Step1: Recognise the adjacent side is unknown a .

Step 2: Write the formula: $c^2 = a^2 + b^2$

Step 3: Sub in the numbers $20^2 = a^2 + 16^2$

$$400 = a^2 + 256$$

$$400 - 256 = a^2 \text{ (Rearrange)}$$

$$144 = a^2$$

$$\sqrt{144} = a$$

$$12 = a$$

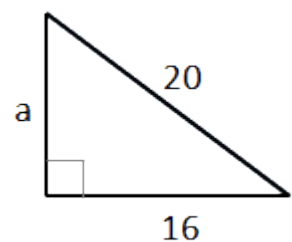

3. Your Turn:

- a. Calculate the unknown side x :

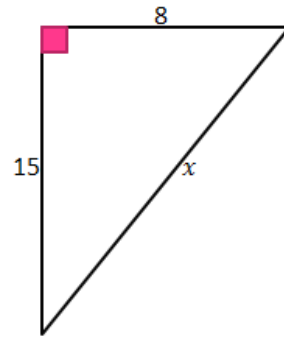

- b. Calculate the unknown side b correct to two decimal places:

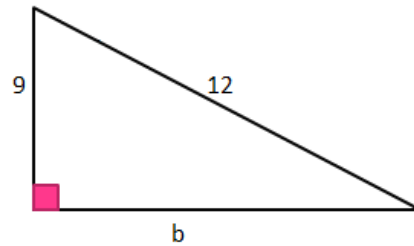

- c. A support wire is required to strengthen the sturdiness of a pole. The pole stands 20m and the wire will be attached to a point 15m away. How long will the wire be?

- d. Here we have a rhombus $ABCD$. It has a diagonal of 8cm. It has one side of 5cm.

i) Find the length of the other diagonal (use Pythagoras Theorem)

ii) Find the area of the rhombus.

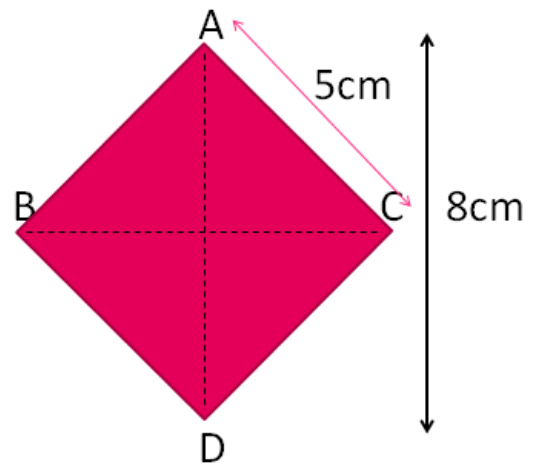

- e. Which of the following triangles is a right angle triangle? Explain why.

- f. Name the right angle.

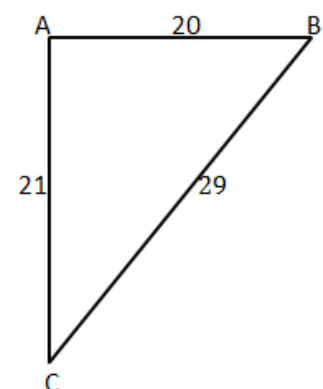
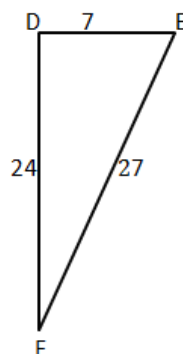

4. Equation of a Circle

The Pythagoras Theorem can do more than just determine the length of an unknown triangle side. It can also be used to write an equation for any circle, given its radius and centre point.

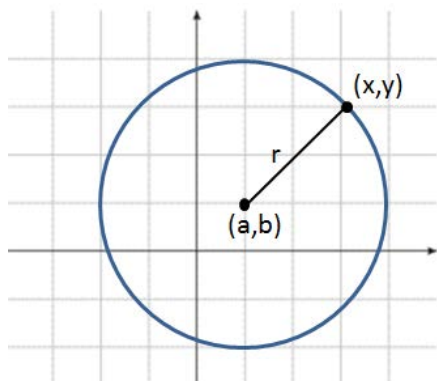

The circle on the left has the centre point (a,b) and the radius r .

Considering that all points on the circle have the distance r from the centre point, how could we describe any point (x,y) on the circle in relation to what we already know about the circle, i.e. the coordinates of its centre point and the length of its radius?

One possibility is to draw a right-angled triangle with (a,b) and (x,y) as corner points and relate the length of the triangle's shorter sides to the radius using Pythagoras because the radius is the triangle's hypotenuse.

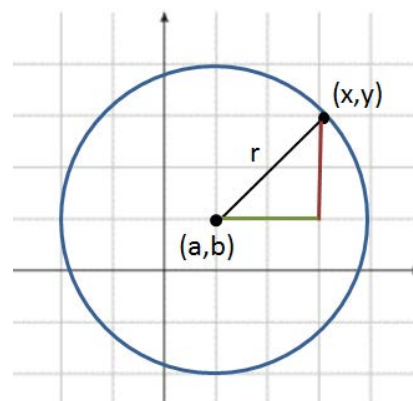

But how would we express the lengths of the red and green triangle sides with what we know?

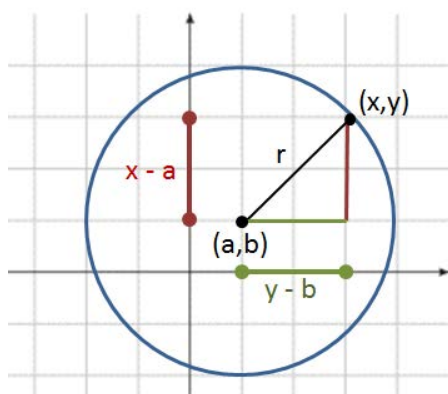

The lengths of the shorter two triangle sides can be expressed as distance between the coordinates of the point (x,y) on the circle and the centre point (a,b) , i.e. " $x - a$ " and " $y - b$ ".

Now we can express the relationship between the two shorter sides of the right-angled triangle and its hypotenuse r :

$$(x - a)^2 + (y - b)^2 = r^2$$

This is the general equation of a circle.

Let's apply this to a concrete example!

EXAMPLE PROBLEM:

Find the equation for a circle with the radius 4 and the centre point $(5, -5)$.

What do we know?

$r = 4$ centre point: $(5, -5)$

Therefore, the circle's equation is $(x - 5)^2 + (y - (-5))^2 = 4^2$

$$(x - 5)^2 + (y + 5)^2 = 16$$

4. Your Turn:

a) What are the coordinates of the centre point and the radius of the following circle?

$$(x + 3)^2 + (y - 4)^2 = 49$$

b) Give the equation of the following circle:

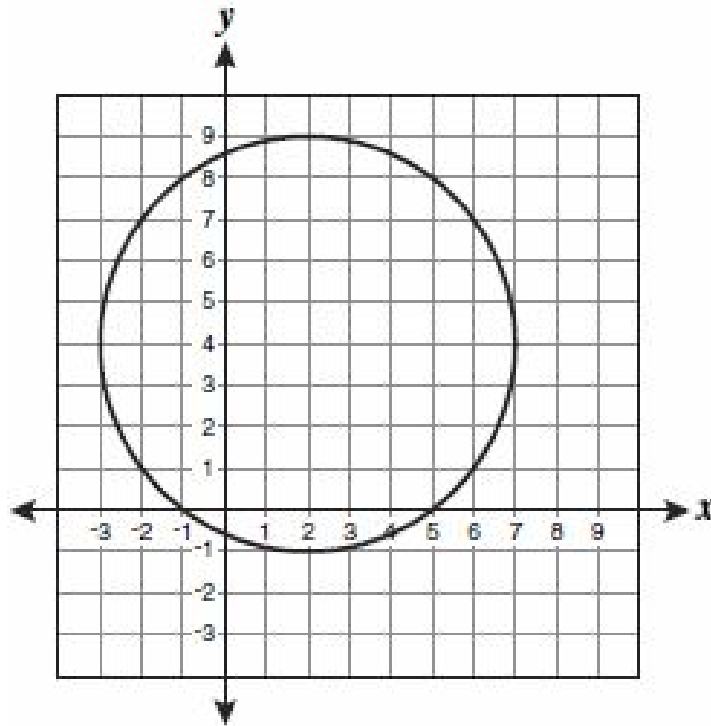

c) Challenge for Algebra fans:

What are the coordinates of the centre point and the radius of the following circle? You might like to refer to Module 6: Algebra – solving Equations, section five dealing with concepts related to factorising.

$$x^2 + y^2 + 4x - 4y - 17 = 0$$

5. Trigonometric Functions: Sine, Cosine and Tangent

In this section we extend on the Pythagoras Theorem, which relates to the three sides of a right angled triangle, to trigonometrical ratios, which help to calculate an angle of a triangle involving lengths and angles of right angle triangles. This is a basic introduction to trigonometry that will help you to explore the concept further in your studies.

Often angles are marked with ' θ ' which is the Greek letter 'theta'. This symbol helps to identify which angle we are dealing with.

For instance, to describe the right angle triangle (right)

The side BC is opposite θ

The side AC is adjacent θ

The opposite side of the right angle is the hypotenuse AB

The trigonometrical ratios do not have units of measure themselves – they are ratios. The three ratios are cosine of θ , the sine of θ and the tangent of θ . These are most often abbreviated to sin, cos and tan.

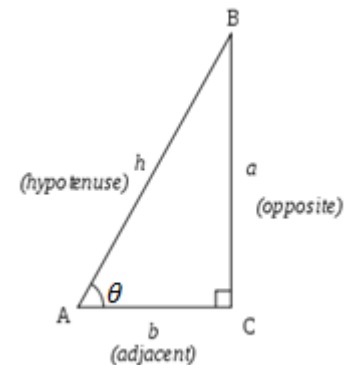

We can calculate an angle when given one of its trigonometrical ratios.

The ratios depend on which angles and sides are utilised

The three ratios are:

$$\circ \sin A = \frac{\textit{opposite}}{\textit{hypotenuse}}$$

$$\circ \cos A = \frac{\textit{adjacent}}{\textit{hypotenuse}}$$

$$\circ \tan A = \frac{\textit{opposite}}{\textit{adjacent}}$$

If you are required to work with these ratios, you might like to memorise the ratios as an acronym SOHCAHTOA pronounced “sock – a- toe – a” or the mnemonic: “**Some Old Humans Can Always Hide Their Old Age.**”

The formulas can be used to either find an unknown side or an unknown angle.

EXAMPLE PROBLEMS:

1. Find x

Step 1: Label the triangle: 19m is the hypotenuse and x is adjacent to the 60°

Step 2: Write the correct formula: $\cos A = \frac{\textit{adjacent}}{\textit{hypotenuse}}$

Step 3: Sub in the numbers: $\cos 60 = \frac{x}{19}$

Step 4: Rearrange the formula: $19 \cos 60 = x$

Step 5: Enter into calculator: $9.5 = x$

Therefore, Side $x = 9.5$ m

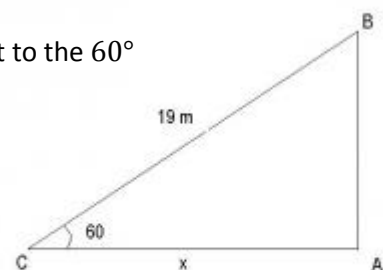

2. Find a

Step 1: Label the triangle: 6.37in is opposite and 15.3in is adjacent to the angle

Step 2: Write the correct formula: $\tan A = \frac{\textit{opposite}}{\textit{adjacent}}$

Step 3: Sub in the numbers: $\tan a = \frac{6.37}{15.3}$

Step 4: Rearrange the formula: $a = \tan^{-1}\left(\frac{6.37}{15.3}\right)$

Step 5: Enter into calculator: $a = 22.6^\circ$

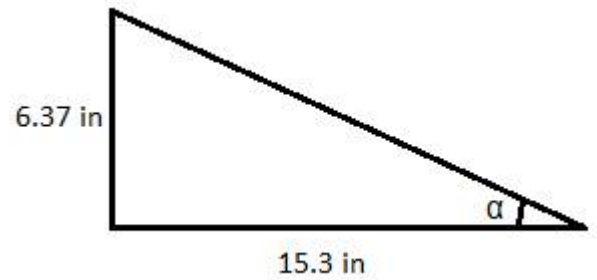

5. Your Turn:

a) Find both angles in the triangle below.

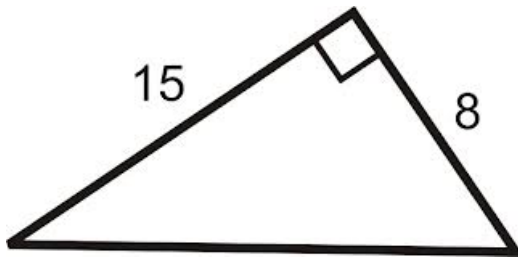

b) Find C in the triangle below.

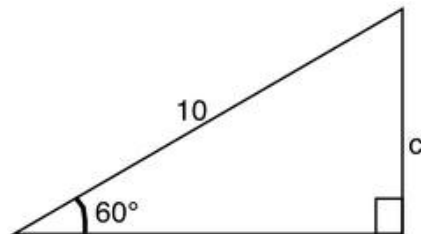

c) Find X in the triangle below.

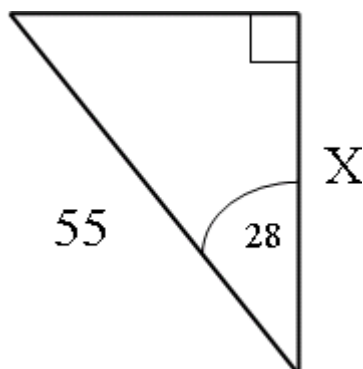

6. Applying Trigonometric Functions

Trigonometric Functions are used in a wide range of professions to solve measurement problems, e.g. architecture, cartography, navigation, land-surveying and engineering. Less obvious uses include the study of distances between stars in astronomy and more abstract applications in geophysics, medical imaging, seismology and optics. The sine and cosine functions are particularly important to the theory of periodic functions such as those that describe sound and light waves.

To simulate the real world application of trigonometric functions, you may be asked to solve word problems like the ones below in your exams.

EXAMPLE PROBLEMS:

- 1) If the distance of a person from a tower is 100 m and the angle subtended by the top of the tower with the ground is 30° , what is the height of the tower in meters?

Step 1:

Draw a simple **diagram** to represent the problem. Label it carefully and clearly mark out the quantities that are given and those which have to be calculated. Denote the unknown dimension by say h if you are calculating height or by x if you are calculating distance.

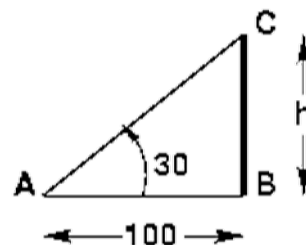

Step 2:

Identify which trigonometric function represents a ratio of the side about which information is given and the side whose dimensions we have to find out. Set up a **trigonometric equation**.

AB = distance of the man from the tower = 100 m

BC = height of the tower = h (to be calculated)

The trigonometric function that uses AB and BC is $\tan a$, where $a = 30^\circ$

Step 3:

Substitute the value of the trigonometric function and **solve the equation** for the unknown variable.

$$\tan 30^\circ = \frac{BC}{AB} = \frac{h}{100m}$$

$$h = 100m \times \tan 30^\circ = 57.74m$$

- 2) From the top of a light house 60 meters high with its base at the sea level, the angle of depression of a boat is 15 degrees. What is the distance of the boat from the foot of the light house?

Step 1: **Diagram**

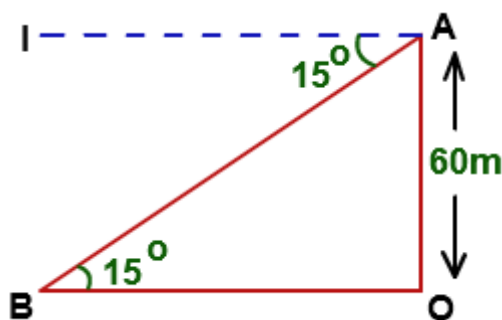

OA is the height of the light house

B is the position of the boat

OB is the distance of the boat from the foot of the light house

Step 2: Trigonometric Equation

$$\tan 15^\circ = \frac{OA}{OB}$$

Step 3: Solve the equation

$$\tan 15^\circ = \frac{60m}{OB}$$

$$OB = 60m \div \tan 15^\circ = 223.92m$$

6. Your Turn:

- a) If your distance from the foot of the tower is 200m and the angle of elevation is 40° , find the height of the tower.

- b) A ship is 130m away from the centre of a barrier that measures 180m from end to end. What is the minimum angle that the boat must be turned to avoid hitting the barrier?

- c) Two students want to determine the heights of two buildings. They stand on the roof of the shorter building. The students use a clinometer to measure the angle of elevation of the top of the taller building. The angle is 44° . From the same position, the students measure the angle of depression of the base of the taller building. The angle is 53° . The students then measure the horizontal distance between the two buildings. The distance is 18.0m. How tall is each building?

7. Reciprocal Trigonometric Functions: Cosecant, Secant and Cotangent

Sine, Cosine and Tangent are human constructed operations (like multiplication or addition) that help us better understand triangles and that are useful in a range of professions. Next to Sine, Cosine and Tangent, mathematicians have defined three other trigonometric functions: Cosecant, Secant and Cotangent. These functions are simply the reciprocals of the Sine, Cosine and Tangent functions respectively.

To calculate them, we divide the triangle sides “the other way around”:

Sine Function: $\sin A = \frac{\textit{opposite}}{\textit{hypotenuse}}$	Cosecant Function: $\csc A = \frac{\textit{hypotenuse}}{\textit{opposite}}$
Cosine Function: $\cos A = \frac{\textit{adjacent}}{\textit{hypotenuse}}$	Secant Function: $\sec A = \frac{\textit{hypotenuse}}{\textit{adjacent}}$
Tangent Function: $\tan A = \frac{\textit{opposite}}{\textit{adjacent}}$	Cotangent Function: $\cot A = \frac{\textit{adjacent}}{\textit{opposite}}$

Note that the reciprocal function of **Sine** is **Cosecant** and the reciprocal function of **Cosine** is **Secant**, even though this is counterintuitive.

To calculate Csc, Sec and Cot on your calculator, enter “1 over sin, cos or tan of the desired angle”,

e.g. $\csc a = \frac{1}{\sin a}$

EXAMPLE PROBLEM:

Give all six trigonometric ratios for angle a in the triangle below.

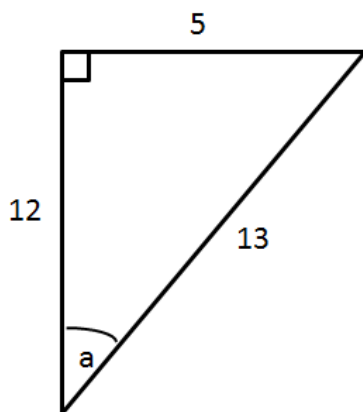

First, name the sides of the triangle in relation to the angle a:

- hypotenuse: 13
- opposite: 5
- adjacent: 12

Therefore:

$$\sin a = \frac{\textit{opp}}{\textit{hyp}} = \frac{5}{13} \qquad \csc a = \frac{\textit{hyp}}{\textit{opp}} = \frac{13}{5}$$

$$\cos a = \frac{\textit{adj}}{\textit{hyp}} = \frac{12}{13} \qquad \sec a = \frac{\textit{hyp}}{\textit{adj}} = \frac{13}{12}$$

$$\tan a = \frac{\textit{opp}}{\textit{adj}} = \frac{5}{12} \qquad \cot a = \frac{\textit{adj}}{\textit{opp}} = \frac{12}{5}$$

6. Your Turn:

For the angle b, $\sin b = \frac{5}{\sqrt{41}}$ and $\cot b = \frac{8}{10}$.

Find the values of the other four trigonometric ratios.

8. Answers

1. a. Four triangles b. both 720° c. *each angle* 120°
2. a. $\frac{2\pi}{5} \approx 1.26$ b. 126°
3. a. 17 b. 7.94 c. $25m$ d. i) $6cm$ ii) $24cm^2$
- e. $\triangle ABC$ is a right angle triangle because $21^2 + 20^2 = 29^2$
 whereas $\triangle DEF$ is not because $7^2 + 24^2 \neq 27^2$
- f. $\angle A$ ($\angle BAC$) is a right angle
4. a. centre point: $(-3,4)$ radius: 7 b. $(x-2)^2 + (y-4)^2 = 25$
- c. The trick is to change the equation into a form that resembles the equation of a circle in standard form. We can do this by factorising the given equation:
 $x^2 + y^2 + 4x - 4y - 17 = 0$
 $(x^2 + 4x + 4) + (y^2 - 4y + 4) - 17 = 0 + 4 + 4$
 $(x^2 + 4x + 4) + (y^2 - 4y + 4) - 17 + 17 = 0 + 4 + 4 + 17$
 $(x+2)^2 + (y-2)^2 = 25$
- Therefore, the centre point is $(-2,2)$ and the radius is 5
5. a. $\tan a = \frac{8}{15}$ $a \approx 28^\circ$ Note: to calculate the angle on your calculator, press "Shift" – " $\tan(\frac{8}{15})$ "
 $\tan b = \frac{15}{815}$ $b \approx 62^\circ$
- b. $\sin 60^\circ = \frac{c}{10}$ $c \approx 8.66$
- c. $\cos 28^\circ = \frac{x}{55}$ $x \approx 48.56$

6. a.



$$\tan 40^\circ = \frac{h}{200m} \quad h \approx 167.82m$$

b.

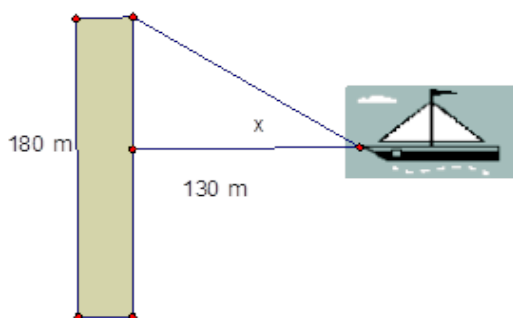

$$\tan x = \frac{90m}{130m} \quad x \approx 34.70^\circ$$

c.

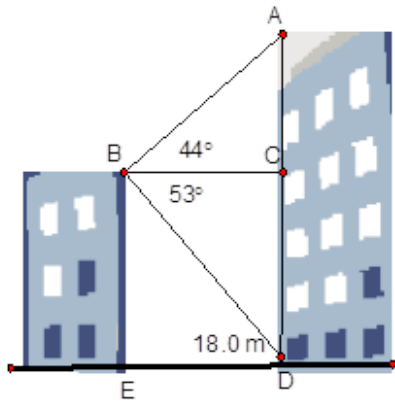

left building:

$$90^\circ - 53^\circ = 37^\circ$$

$$\tan 37^\circ = \frac{18m}{BE} \quad BE \approx 23.89m$$

right building:

$$\tan 44^\circ = \frac{AC}{18m} \quad AC \approx 17.38m$$

$$AD = BE + AC = 23.89m + 17.38m = 41.27m$$

7.

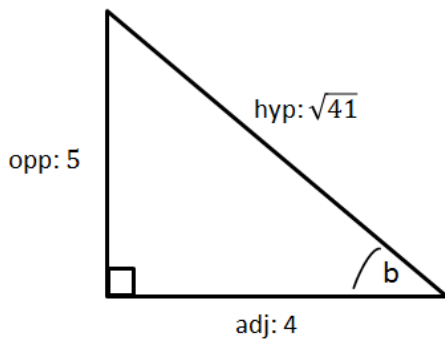

$$\sin b = \frac{opp}{hyp} = \frac{5}{\sqrt{41}}$$

$$\csc b = \frac{hyp}{opp} = \frac{\sqrt{41}}{5}$$

$$\tan b = \frac{opp}{adj} = \frac{5}{4}$$

$$\cot b = \frac{adj}{opp} = \frac{4}{5}$$

$$\text{so, } \frac{adj}{5} = \frac{4}{5} \rightarrow adj = 4$$

$$\tan b = \frac{5}{adj} = \frac{5}{4}$$

$$\cos b = \frac{adj}{hyp} = \frac{4}{\sqrt{41}}$$

$$\sec b = \frac{hyp}{adj} = \frac{\sqrt{41}}{4}$$

9. Helpful Websites

Trigonometry on Khan Academy: <https://www.khanacademy.org/math/trigonometry>

Powers: http://www.mathsteacher.com.au/year8/ch07_indices/01_ind/ind.htm

Roots: <http://www.math.utah.edu/online/1010/radicals/>

Logarithms: <http://www.mathsisfun.com/algebra/logarithms.html>

Pythagoras: <http://www.mathsisfun.com/pythagoras.html>

Sin, Cos & Tan: <http://www.mathsisfun.com/sine-cosine-tangent.html>

Trigonometry: <http://themathpage.com/atrig/trigonometry.htm>

Activity

Insert Instructions

