

# MATLAB EXPO 2019

신호 및 시계열 데이터를  
위한 딥러닝

송완빈

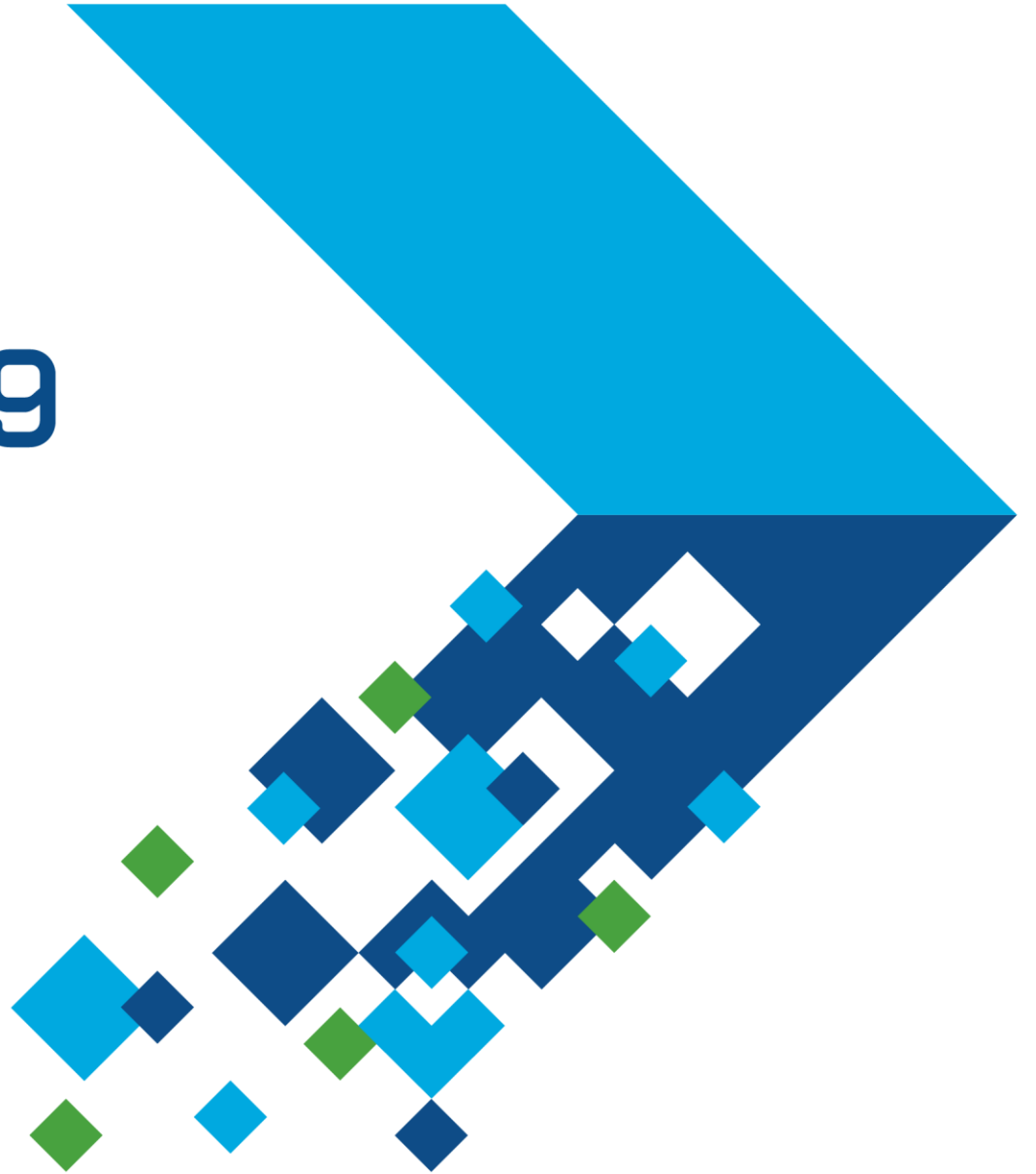

# AI and Deep Learning for Signals in the News



Deep Learning developed and evolved for image processing and computer vision applications.

It is now increasingly and successfully used on signals and time series

Video: Johns Hopkins University

**Tech for a Noisy World:** Researchers simulated an extremely noisy environment in the lab (the sound meter shows levels of around 70 decibels). They compared the audio heard through a top-notch commercial stethoscope, in which the breathing sounds are mixed with ambient noise, to that heard through the Johns Hopkins smart stethoscope, which uses active acoustic filtering to isolate the breathing sounds.

# The Use of Deep Learning is Growing Across Industries

## Aerospace, Defense and Communications



Communications devices, security

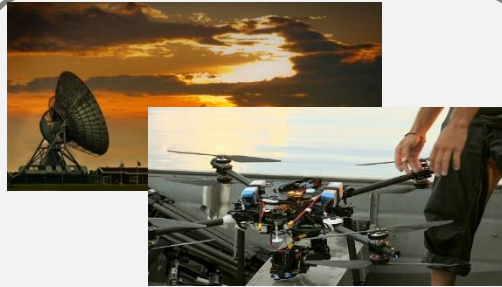

Multi-standard communications receivers, drone recognition

## Consumer Electronics and Digital Health



Voice assistants



Digital health

## Automotive



Voice control enabled Infotainment



Sensor processing, automated driving

## Industrial Automation



Condition monitoring



Predictive maintenance

# Application Examples Using MATLAB – Audio and Speech

The screenshot shows the MATLAB R2018b environment. The main window displays the 'Alexa Running Script' with the following code:

```

1 clear; close all; clc;
2 pp = actxserver('PowerPoint.Application');

3
4 load('speechNet_Trans.mat')

5
6 load('data/speechSpec_Trans.mat')
7
8 frameDuration = 0.025;
9 hopDuration = 0.010;
10 epsilon = 1e-6;
11 X = log10(X + epsilon);
12 sz = size(X);
13 specHeight = sz(1);

```

Below the script, a 'Figure 1' window displays a spectrogram plot of audio data. The x-axis represents time (0 to 16000) and the y-axis represents frequency (-0.2 to 0.2). The plot shows a blue shaded area representing the frequency content of the audio signal.

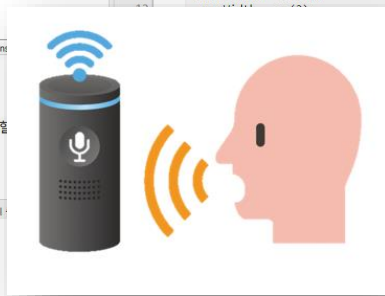

Speech Command Recognition  
(a.k.a. "Keyword Spotting")

<https://www.mathworks.com/help/deeplearning/examples/deep-learning-speech-recognition.html>

The screenshot shows a YouTube video player for 'The Best of Mozart' by HALIDONMUSIC. The video has 167,895,545 views and is published on Jan 8, 2013. The player interface includes a play button, a progress bar, and a 'Pause (k)' button. The video title is 'The Best of Mozart' and the channel name is 'HALIDONMUSIC'.



Music Genre Classification

<https://www.mathworks.com/help/audio/examples/music-genre-classification-using-wavelet-time-scattering.html>

# Application Examples Using MATLAB – Industrial and physiological sensors

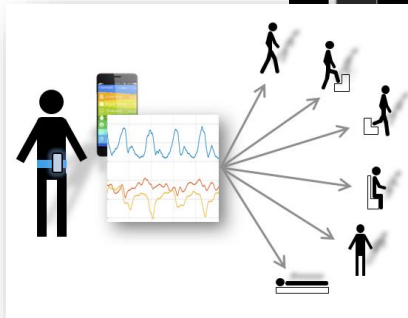
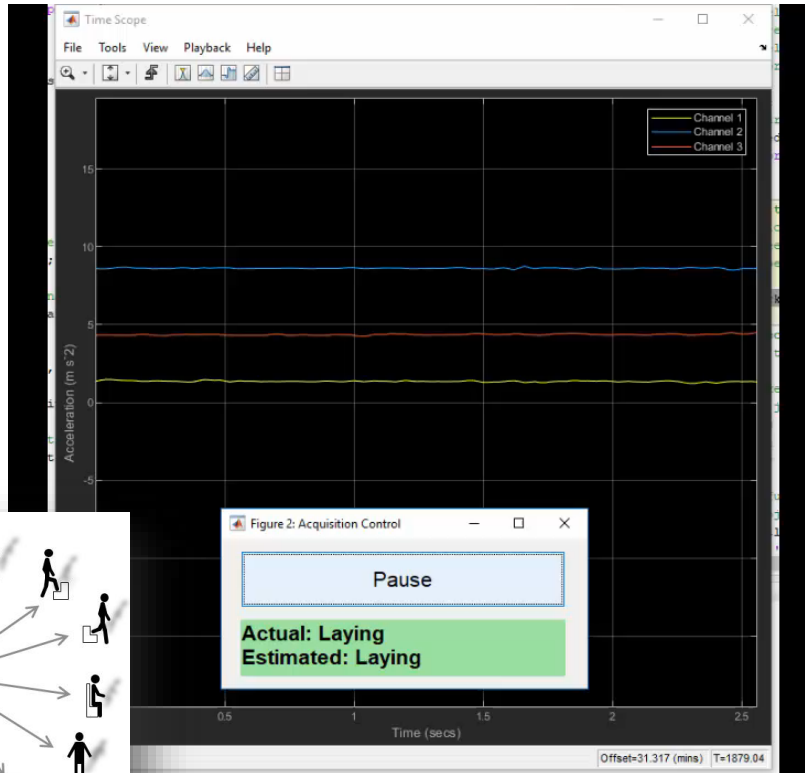

Human Activity Recognition

<https://www.mathworks.com/help/deeplearning/examples/sequence-to-sequence-classification-using-deep-learning.html>

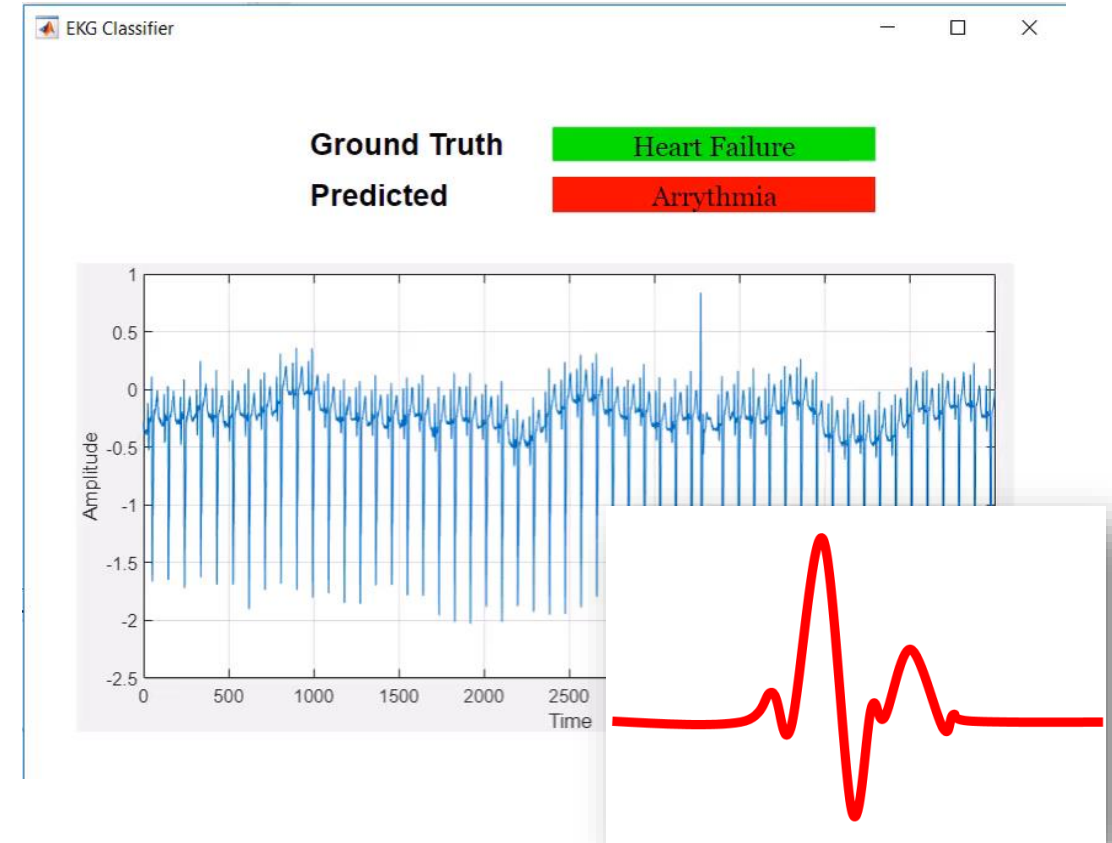

ECG Signal Classification

<https://www.mathworks.com/help/signal/examples/classify-ecg-signals-using-long-short-term-memory-networks.html>

# Application Examples Using MATLAB – Radar and Communications

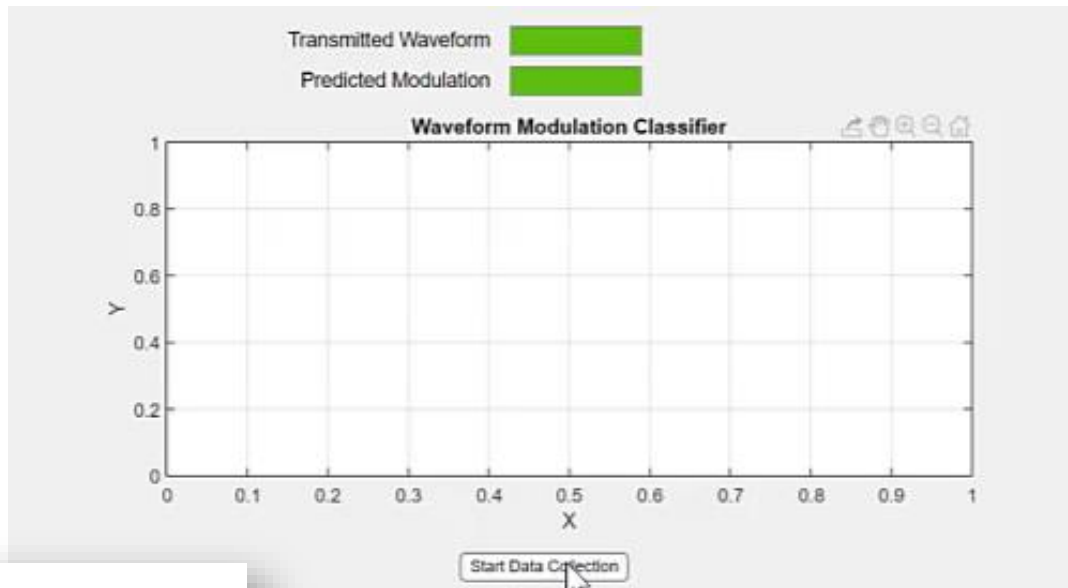

## Modulation Classification

<http://www.mathworks.com/help/comm/examples/modulation-classification-with-deep-learning.html>

**Confusion Matrix for Test Data**

16QAM	89	11								89.0%	11.0%
64QAM	1	99								99.0%	1.0%
8PSK			100							100.0%	
B-FM				100						100.0%	
BPSK					100					100.0%	
CPFSK						100				100.0%	
GFSK							100			100.0%	
PAM4								100		100.0%	
QPSK			4						96	96.0%	4.0%
	16QAM	64QAM	8PSK	B-FM	BPSK	CPFSK	GFSK	PAM4	QPSK		
	Predicted Class										

# Agenda

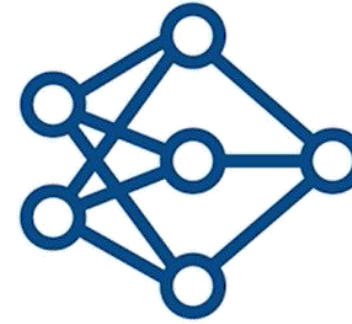

- Deep Learning – Basic ideas
- Deep Learning Model Development for Signals, Time Series, and Text
- Conclusions

# What is Deep Learning?

Deep learning is a type of machine learning in which a model learns from examples.

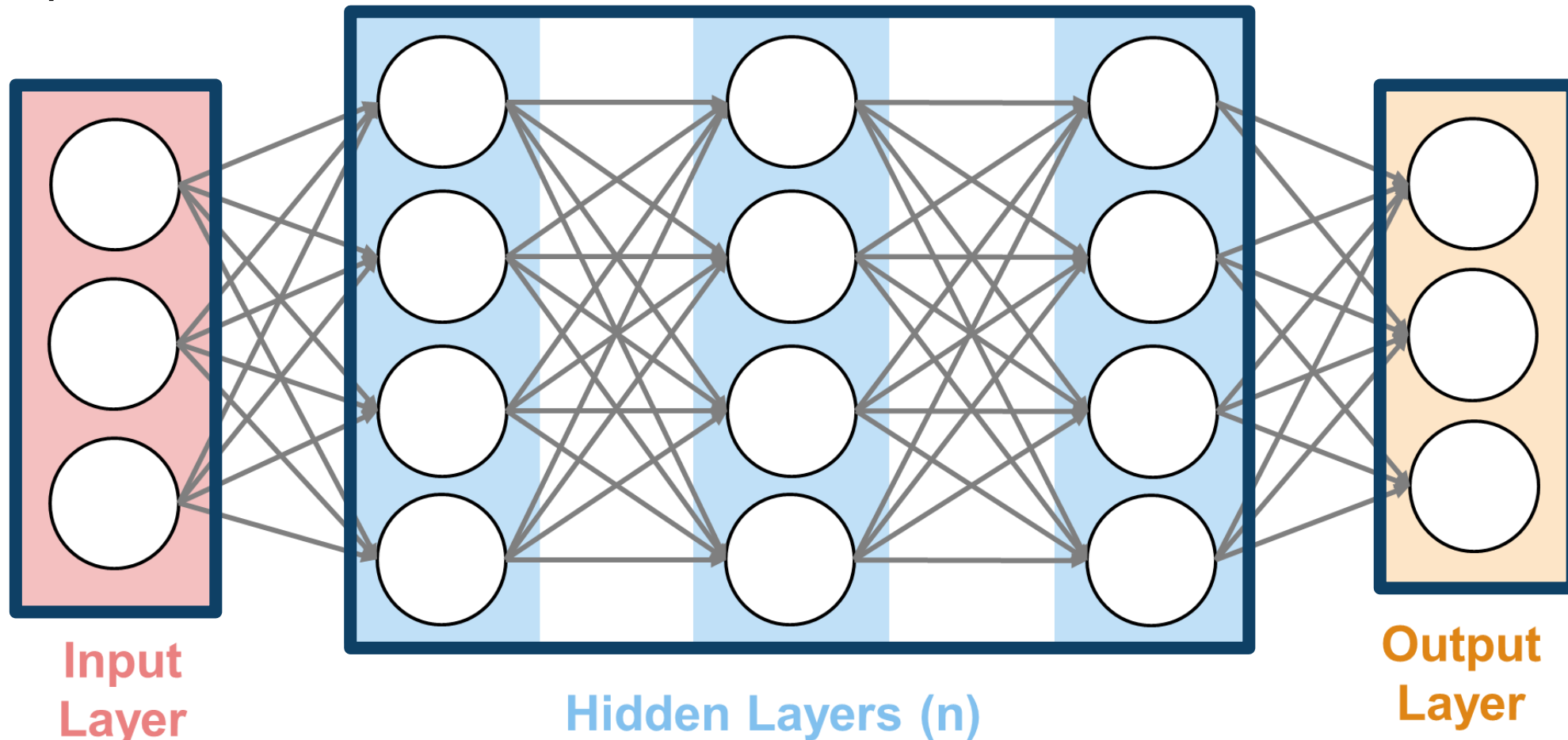



# Common Network Architectures - Signal Processing

## Convolutional Neural Networks (CNN)

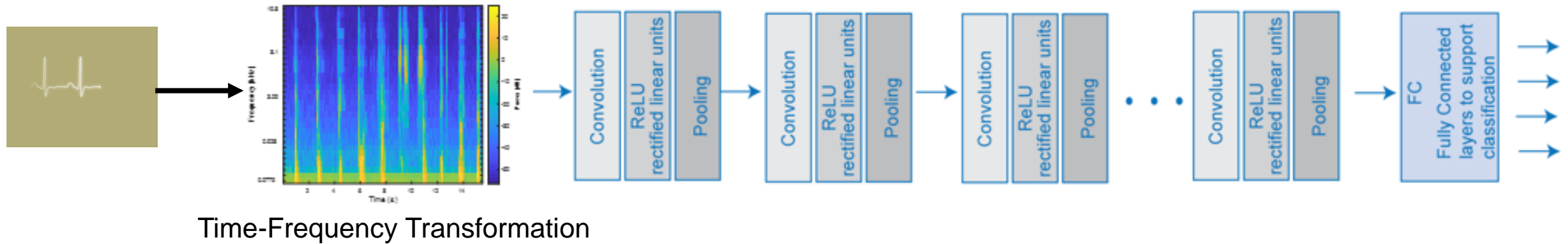

## Long Short Term Memory (LSTM) Networks

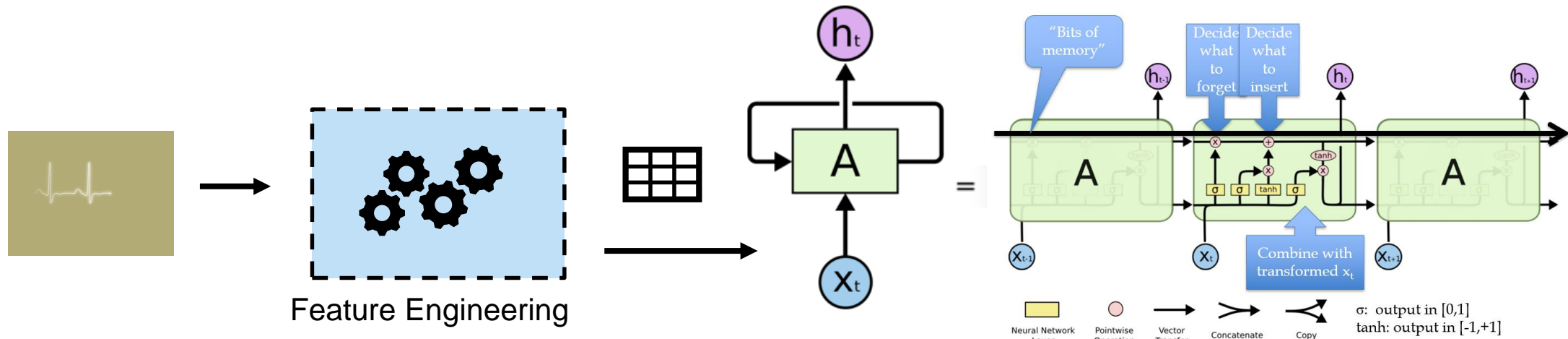

# Common Network Architectures – Text Analytics

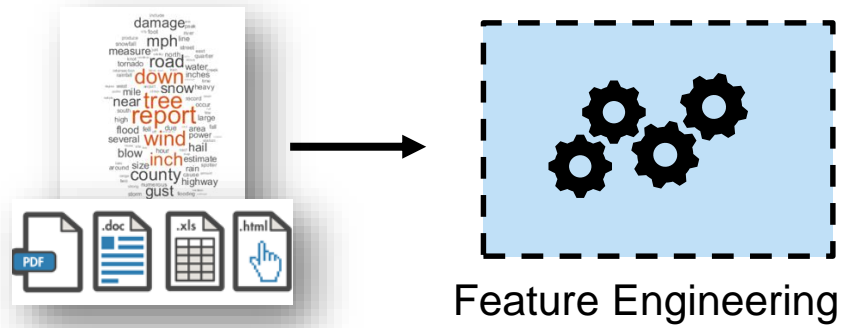

## Convolutional Neural Networks (CNN)

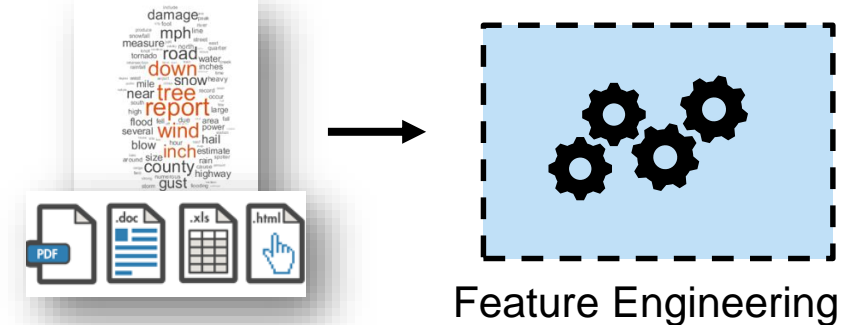

## Long Short Term Memory (LSTM) Networks

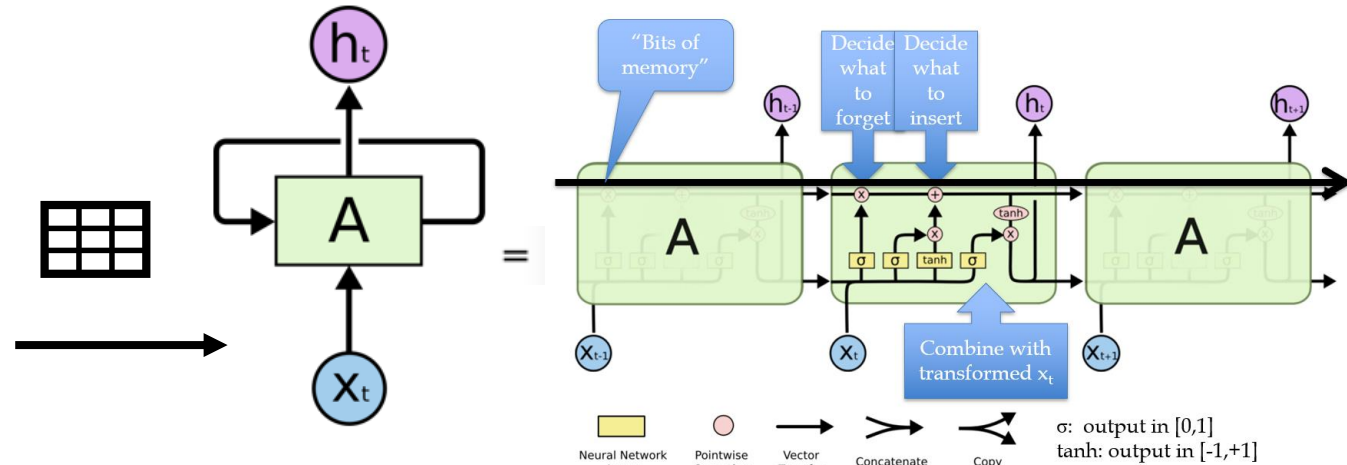

# Deep Learning Workflow

CREATE AND ACCESS DATASETS

PREPROCESS AND TRANSFORM DATA

DEVELOP PREDICTIVE MODELS

ACCELERATE AND DEPLOY

**Data sources**

---

**Simulation and augmentation**

---

**Data Labeling**

**Pre-Processing**

---

**Transformation**

---

**Feature extraction**

**Import Reference Models/ Design from scratch**

---

**Hardware-Accelerated Training**

---

**Analyze and tune hyperparameters**

**Desktop Apps**

---

**Enterprise Scale Systems**

---

**Embedded Devices and Hardware**

# Deep Learning Workflow Challenges – Signals and Time Series

Deep learning models only as good as training data

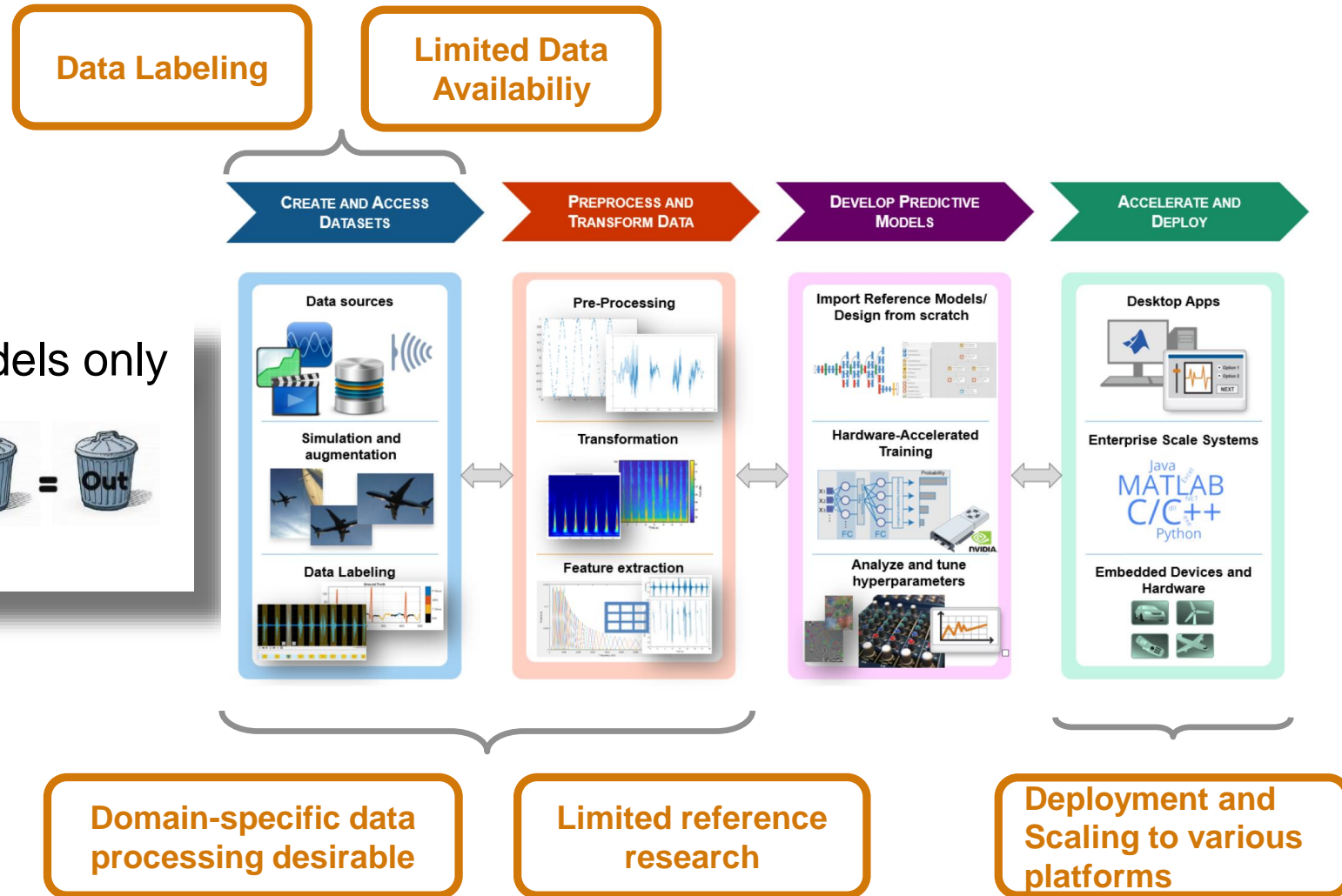
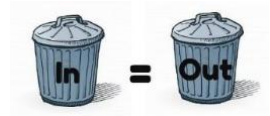

# Agenda

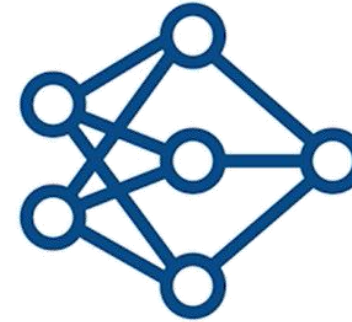

- Deep Learning – Basic ideas
- **Deep Learning Model Development for Signals, Time Series, and Text**
  - Data
  - Processing and transformation
  - Model design and optimization
  - Acceleration, prototyping, and deployment
- Conclusions

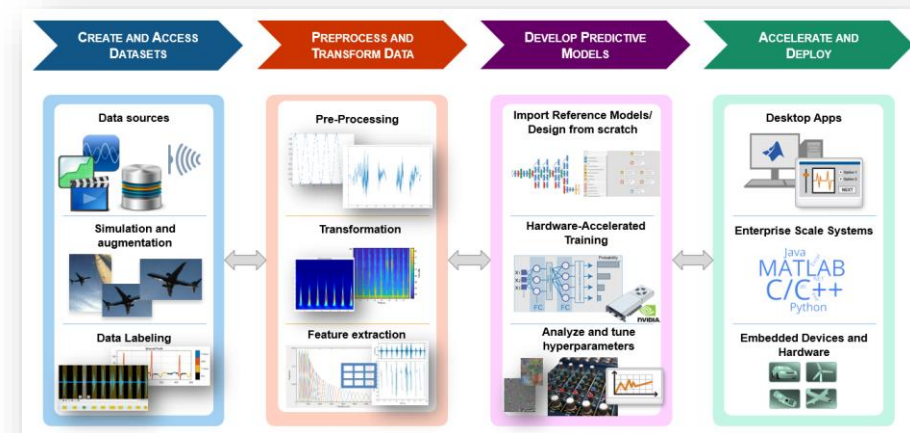

# Agenda

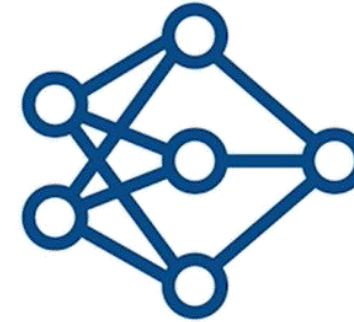

- Deep Learning – Basic ideas
- Deep Learning Model Development for Signals, Time Series, and Text
  - **Data**
  - Processing and transformation
  - Model design and optimization
  - Acceleration, prototyping, and deployment
- Conclusions

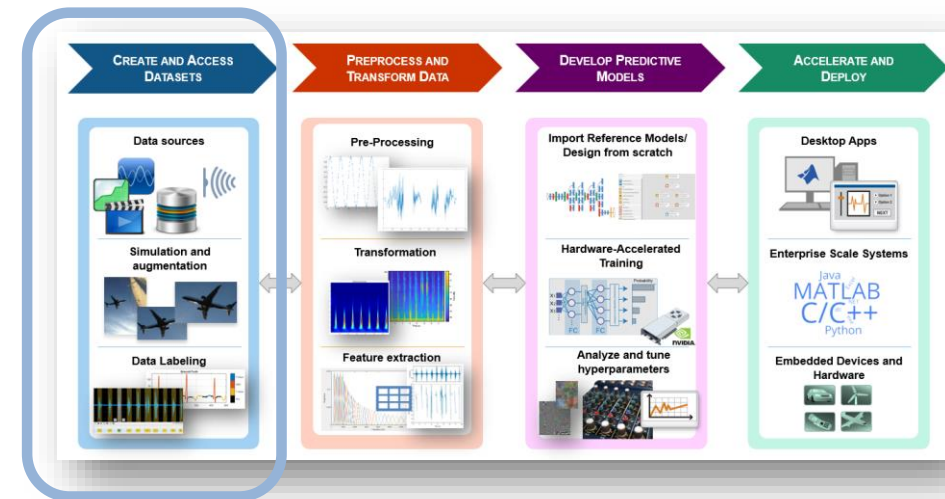

# Current Investments – Models vs. Data

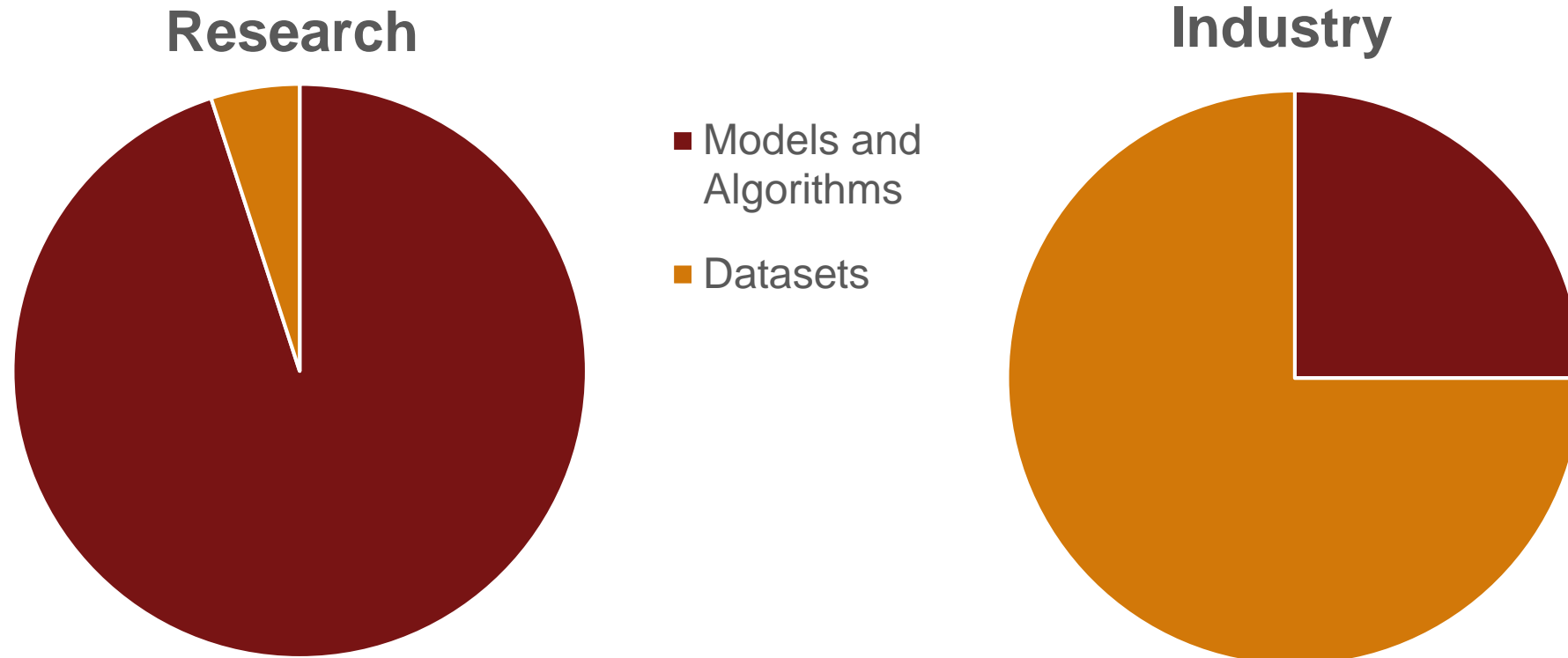

# What does a large dataset look like?

## How to navigate, index, read (and write)

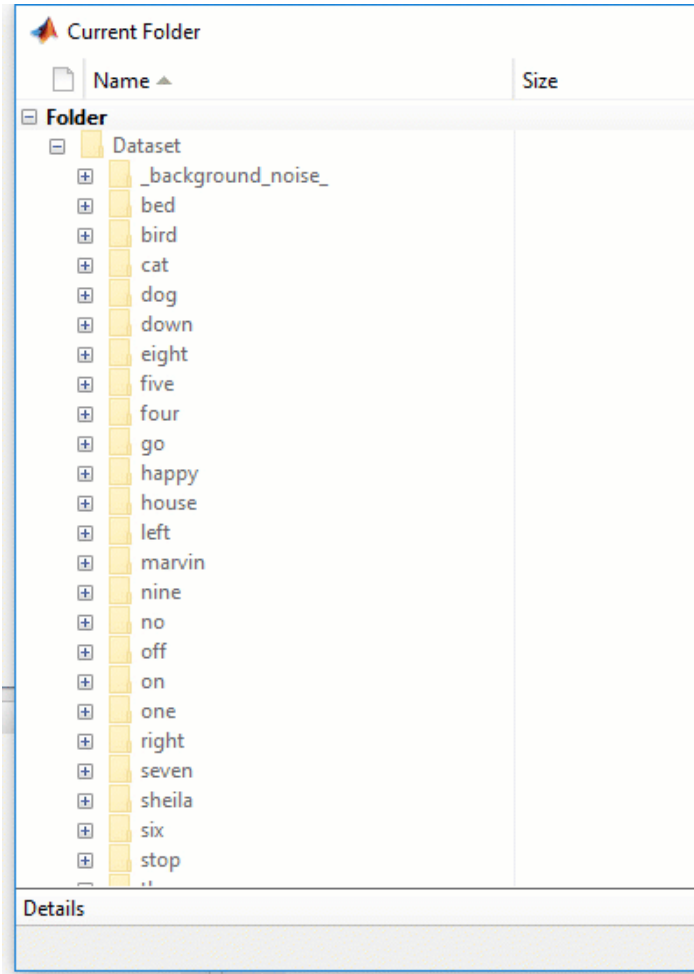

audioDatastore

imageDatastore

fileDatastore

Custom Datastores

How to...

- Build a list of all data and labels?
- Review basic statistics about available data?
- Select data subsets without nested `for` loops, `dir`, `ls`, `what`, ... aplenty?
- Jointly read data and labels?
- Automatically distribute computations?



# Label quality impacts model performance as much as the quality and quantity of the actual recordings

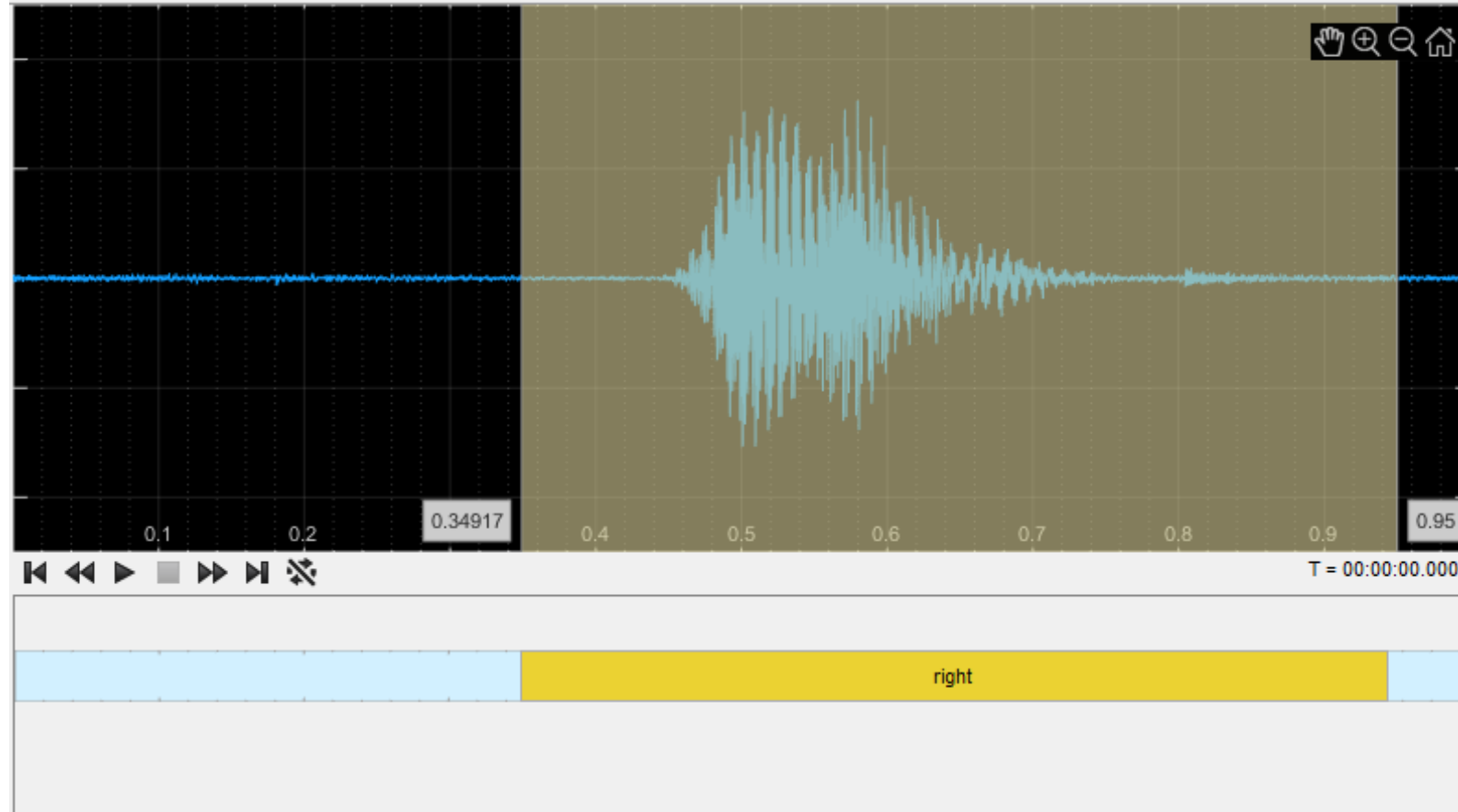

# Use appropriate tools to help you label signals

```

patientID = 1;
signalVals = getSignal(QTData,patientID);
labelVals = getLabelValues(QTData,patientID,'WaveformLabels_Chan1');

displayWaveformLabels(signalVals(1,1:1000),labelVals.Value(1:1000))
    
```

Inspect the label values

- Programmatically...

- ... or via Apps

# What if available data isn't enough?

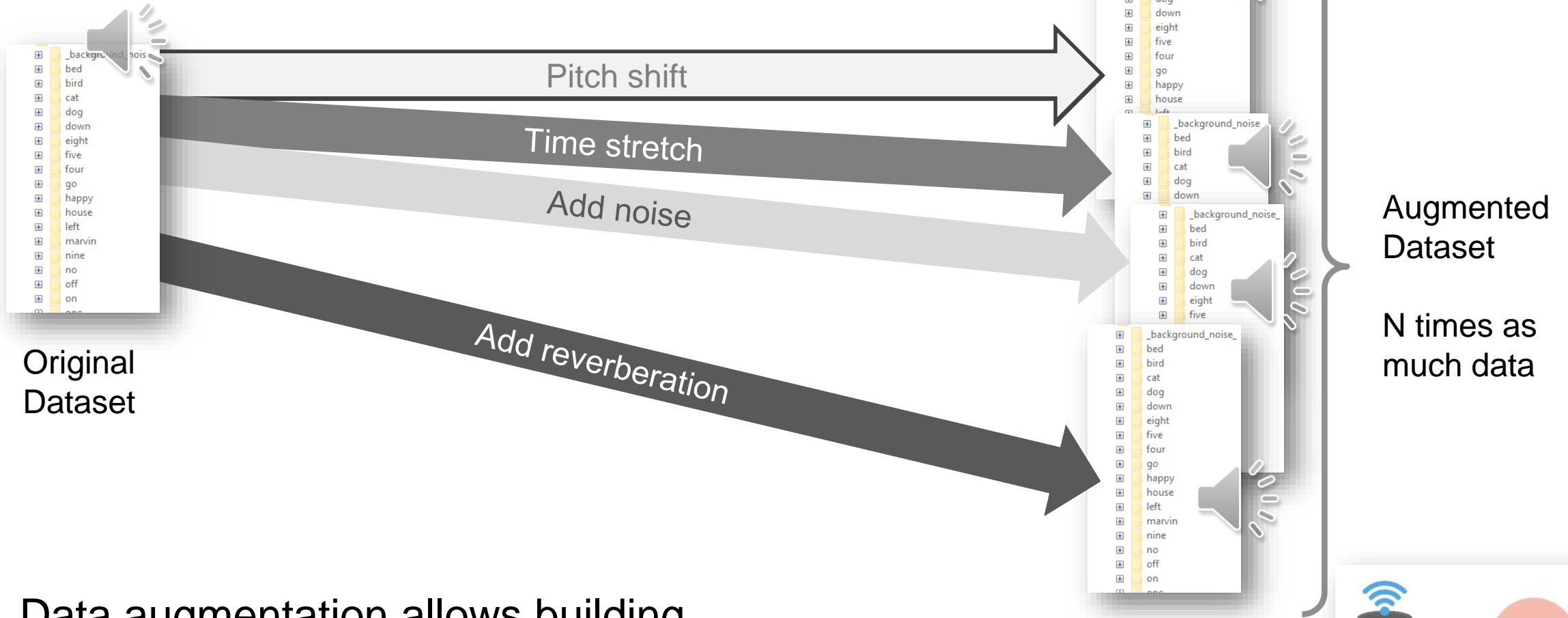

Data augmentation allows building more complex and more robust models

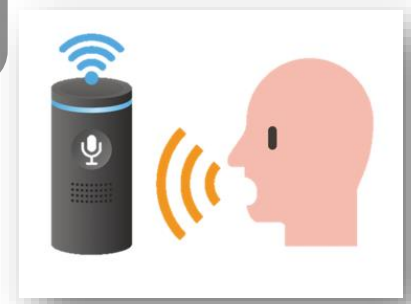

# Simulation is key if recording and labelling real-world data is impractical or unreasonable – Communications Signals

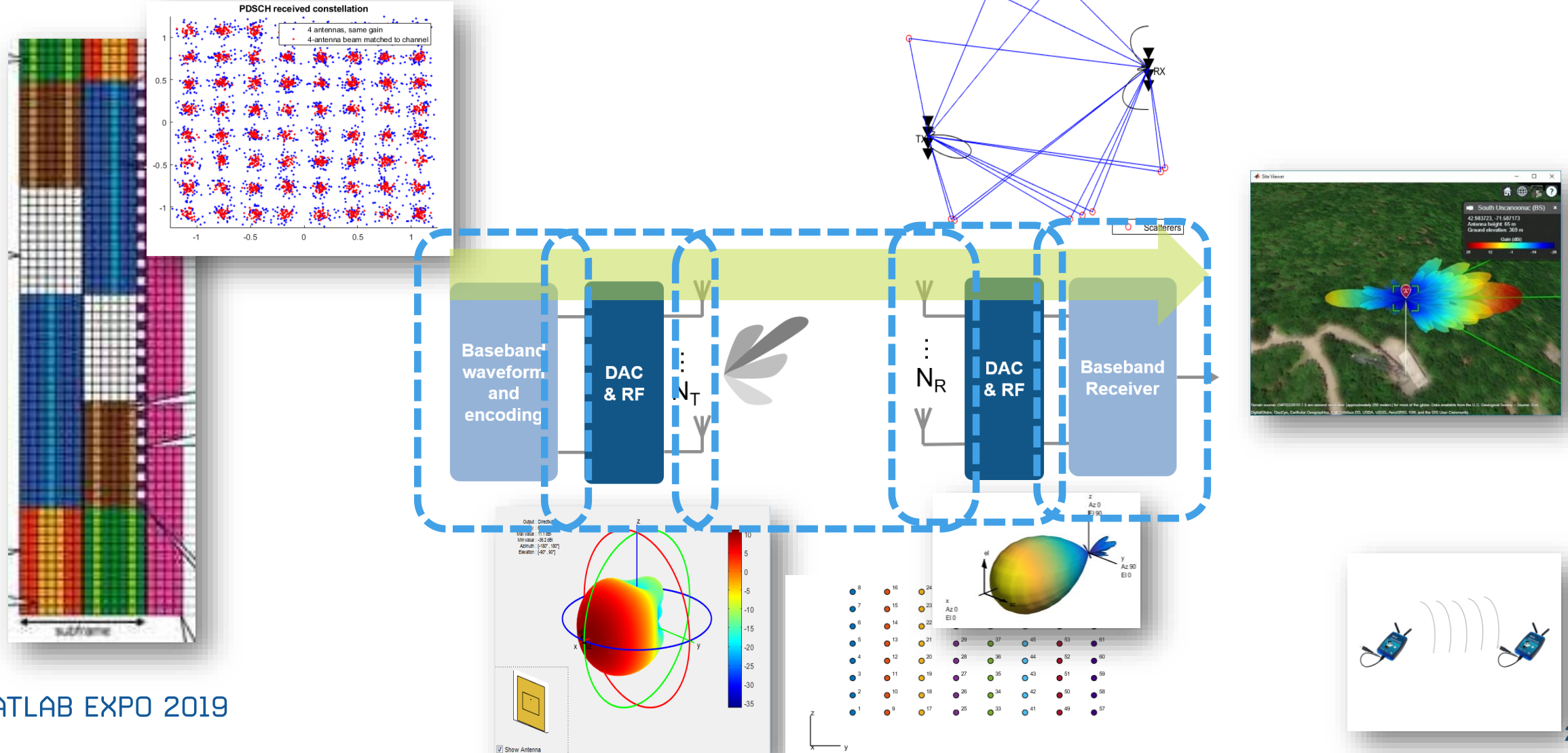

# Simulation is key if recording and labelling real-world data is impractical or unreasonable – Radar Signals

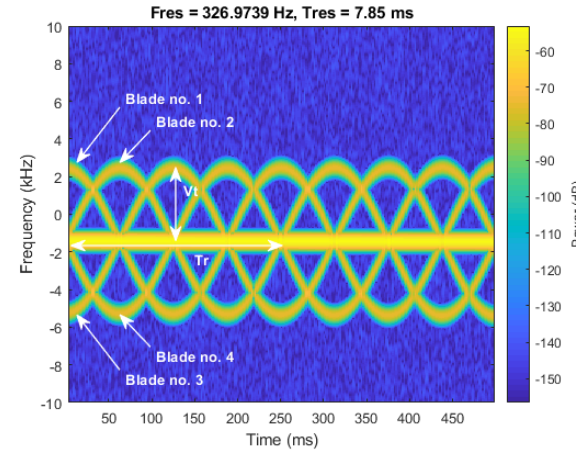
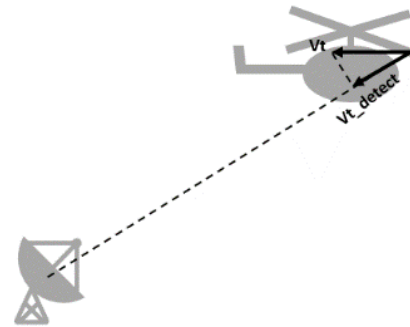

Radar Target Simulation

Micro-Doppler Analysis

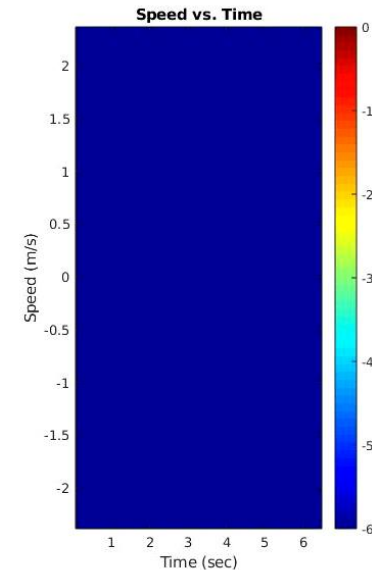
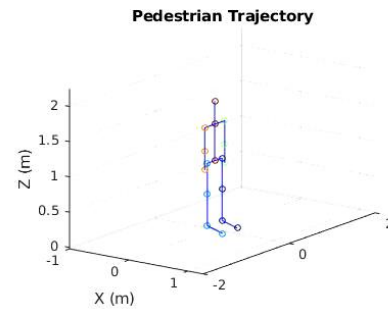

# Agenda

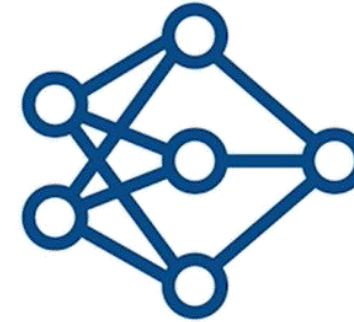

- Deep Learning – Basic ideas
  
- Deep Learning Model Development for Signals, Time Series, and Text
  - Data
  - **Processing and transformation**
  - Model design and optimization
  - Acceleration, prototyping, and deployment
  
- Conclusions

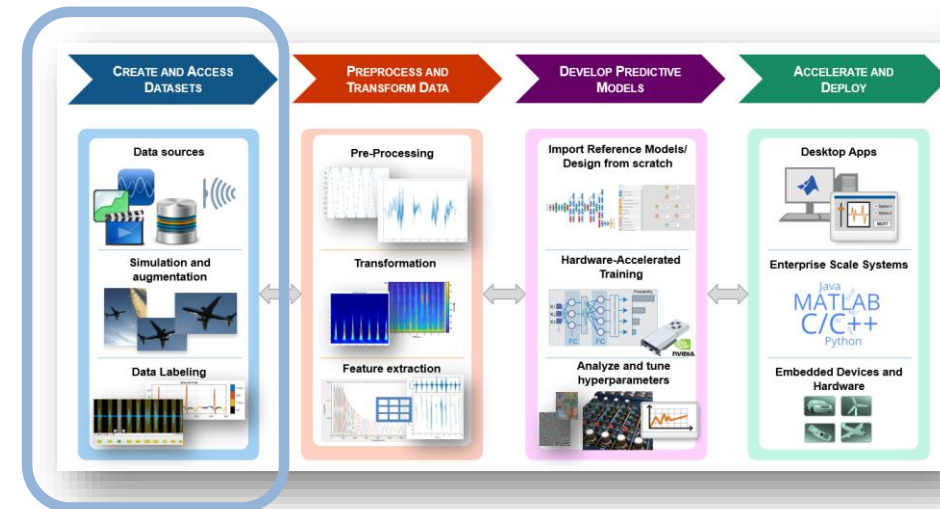

# Common types of network architectures used in signal processing and text analytics applications

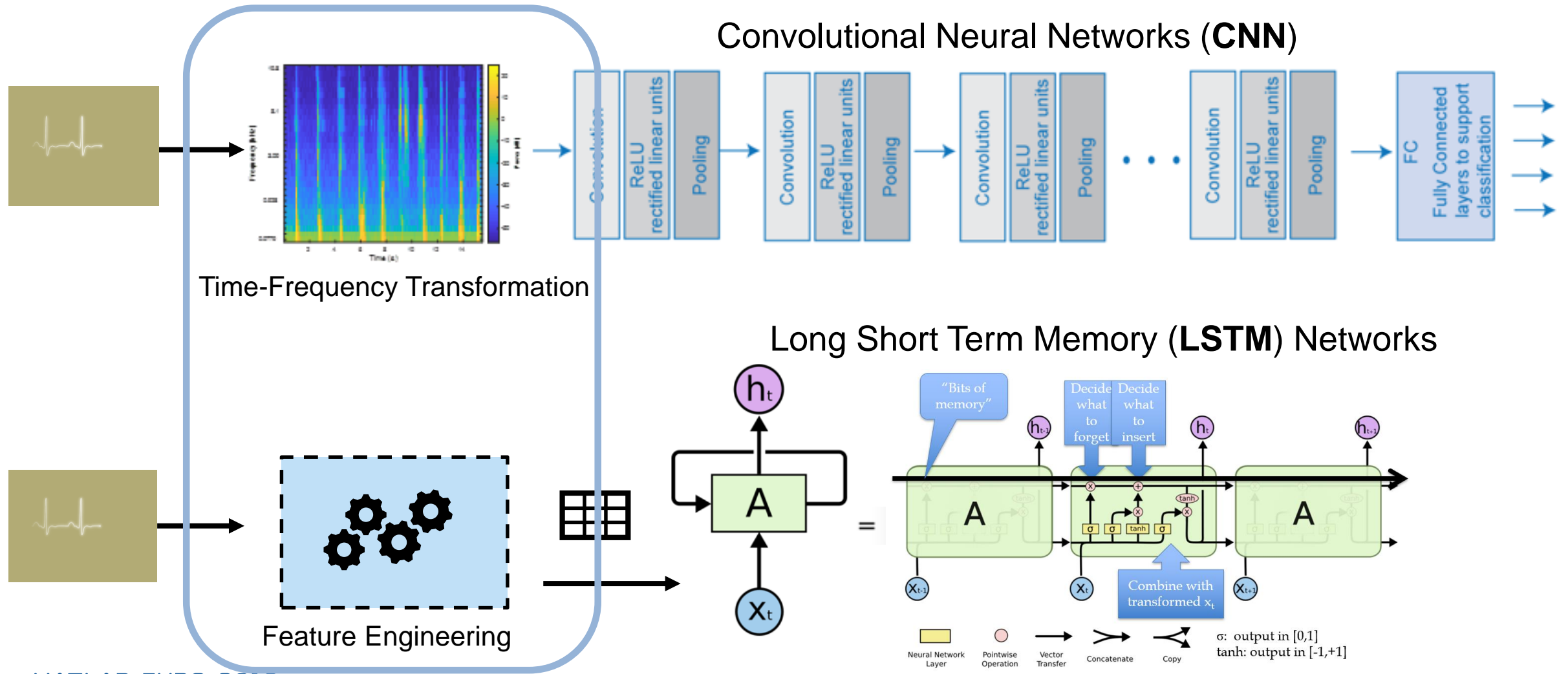

# Time-Frequency Transformations

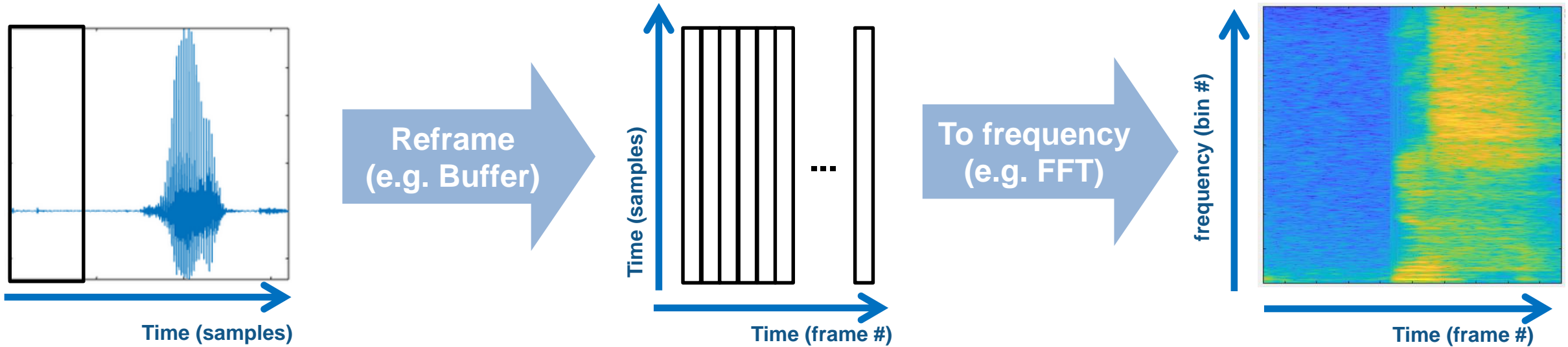

Easiest to understand and implement

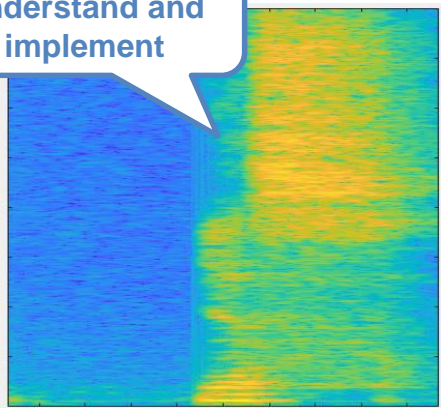

Basic spectrogram  
MATLAB EXPO 2019

More compact for speech & audio applications

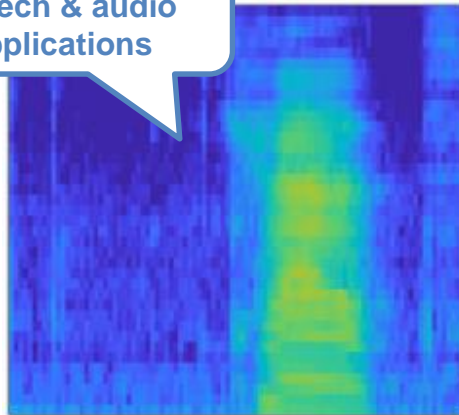

Perceptually-spaced (e.g. Mel, Bark) Spectrogram

Best resolution, for non-periodic signals

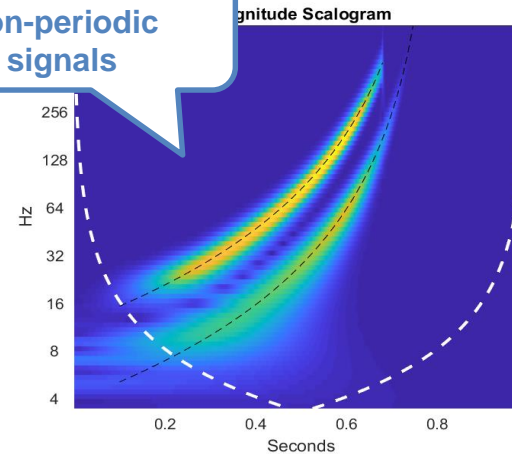

Wavelet scalogram

Better resolution at low frequencies

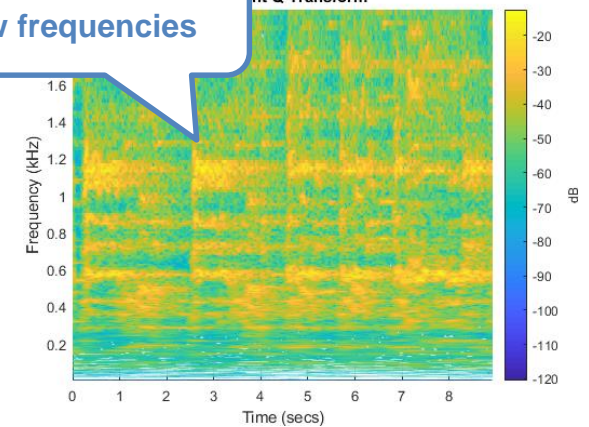

Constant Q transform



# Extracting Features from Signals: Application-Agnostic Examples

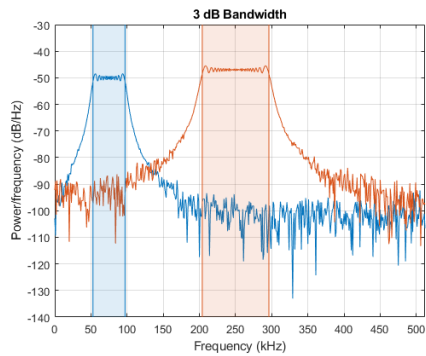

BW measurements

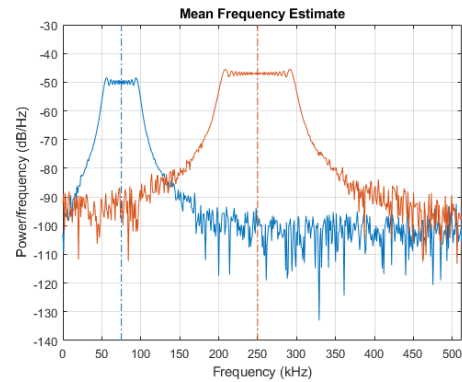

Spectral statistics

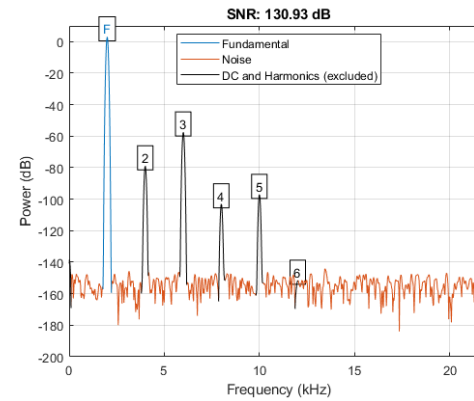

Harmonic analysis

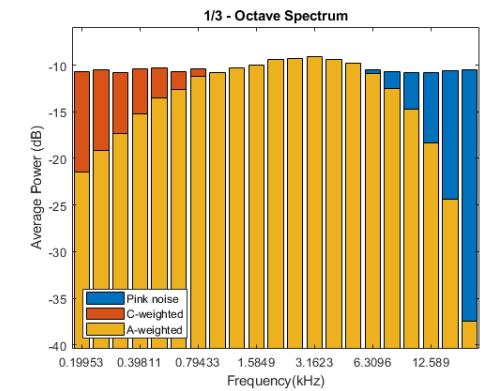

Octave spectrum

## Frequency domain

## Time domain

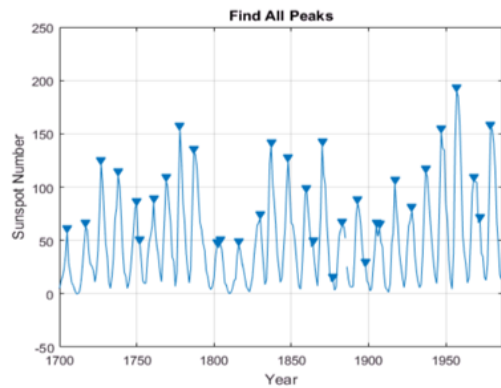

Find peaks

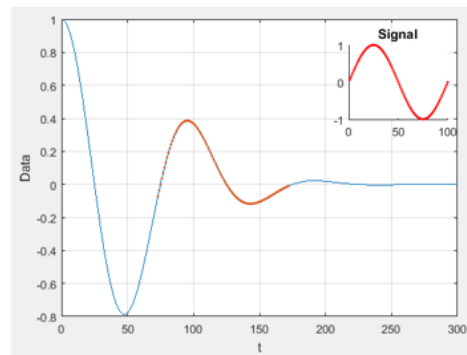

Find signal patterns

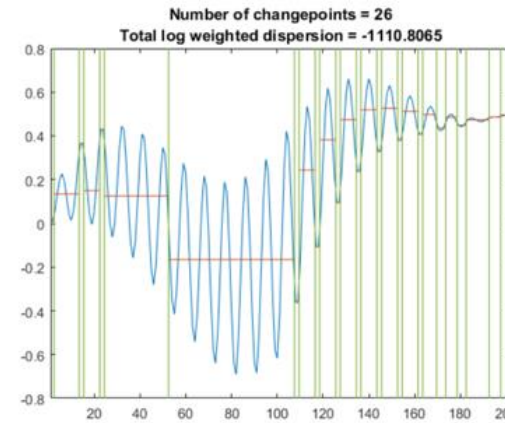

Detect change points

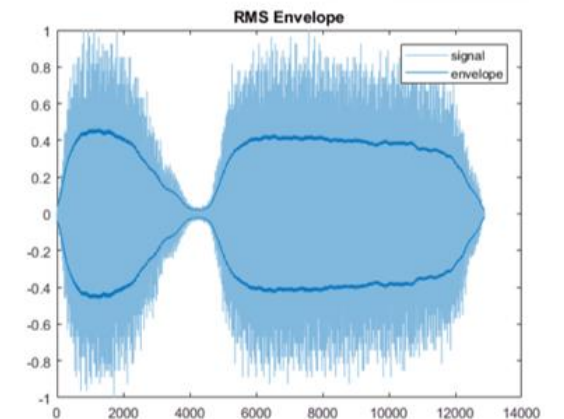

Find signal envelope

# Domain-Specific Features and Transformations – Examples

## Speech and Audio

- MFCC
- GTCC
- MDCT
- Pitch, harmonicity
- Spectral shape descriptors
- ...

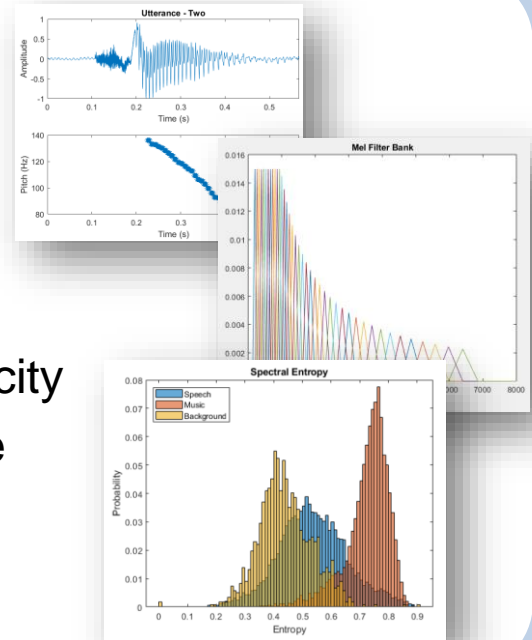

## Navigation and Sensor Fusion

- Orientation
  - Height
  - Position
- from
- Acceleration, angular velocity
  - Magnetic field
  - GPS reading
- Multi-object tracking
  - ...

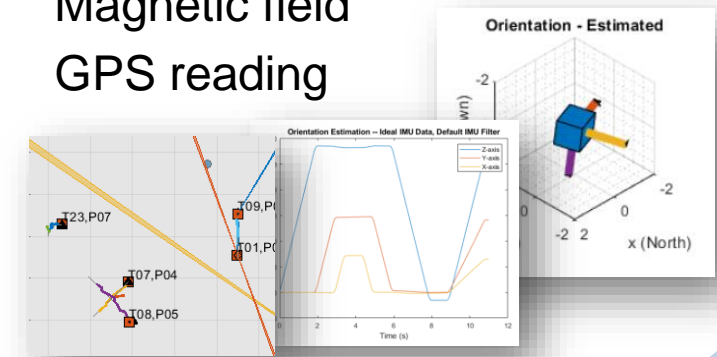

## Text Analytics

- Train Word Embeddings
- Word2Vec
- Topic Modeling
- ...

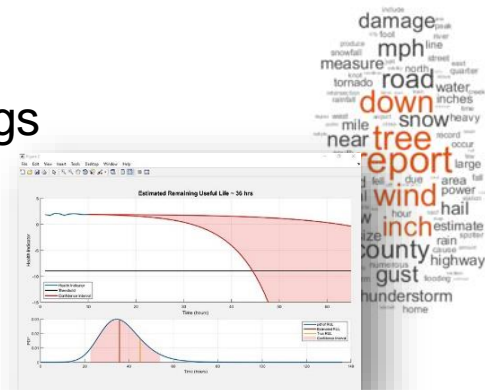

## Radar

- Micro-Doppler analysis
- Range-Doppler processing
- Synthetic aperture imaging
- Spectral analysis
- Waveform ambiguity
- ...

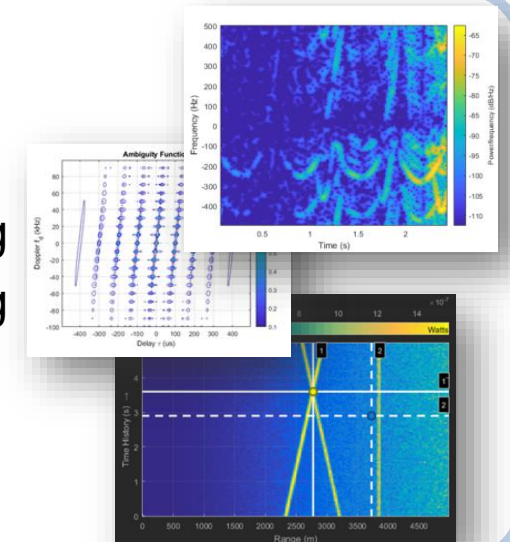

# Automated Feature Extraction: Wavelet Scattering

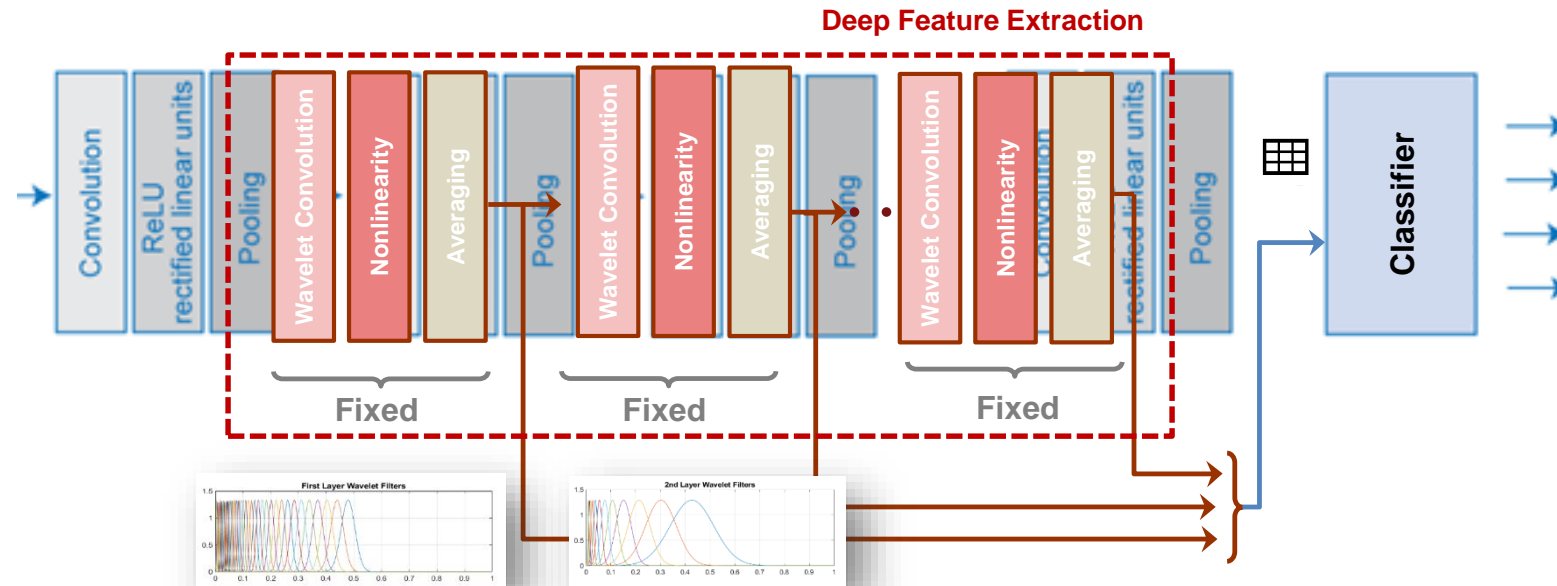

- Can relieve requirements on amount of data and model complexity
  - Featured in leader-boards a number of research competitions
- Framework for extracting features <sup>[1]</sup>

[1] Joan Bruna, and Stephane Mallat, P. 2013. Invariant Scattering Convolution Networks. [IEEE Transactions on Pattern Analysis and Machine Intelligence](#), Vol. 35, No. 8, pp. 1872-1886.



# Agenda

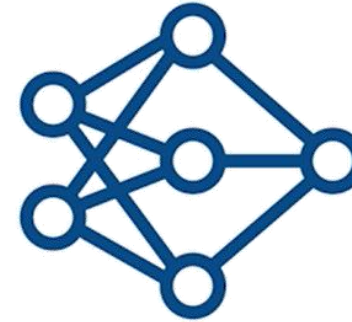

- Deep Learning – Basic ideas
- Deep Learning Model Development for Signals, Time Series, and Text
  - Data
  - Processing and transformation
  - **Model design and optimization**
  - Acceleration, prototyping, and deployment
- Conclusions

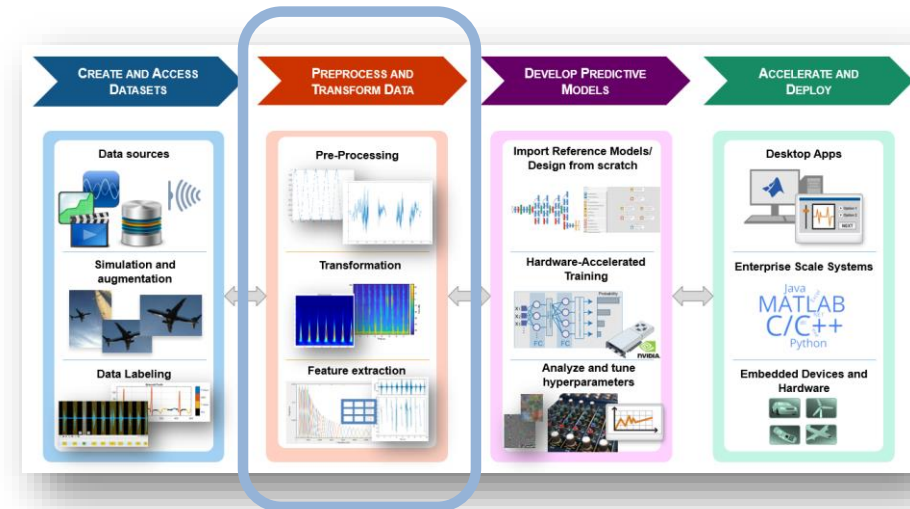

# Developing Deep Learning Models

## Design Network



## Design

## Model Exchange

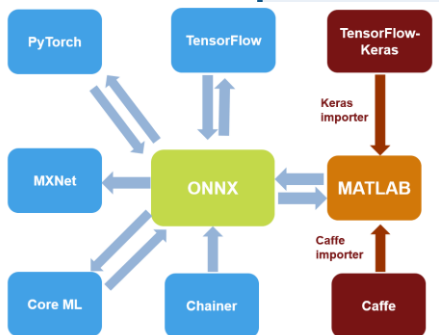

## Pre-trained Networks

<b>AlexNet</b> PRETRAINED MODEL	<b>VGG-16</b> PRETRAINED MODEL	<b>ResNet-50</b> PRETRAINED MODEL	<b>ONNX Converter</b> MODEL CONVERTER
<b>Caffe</b> IMPORTER	<b>GoogLeNet</b> PRETRAINED MODEL	<b>TensorFlow-Keras</b> IMPORTER	<b>Inception-v3</b> MODELS

## Train

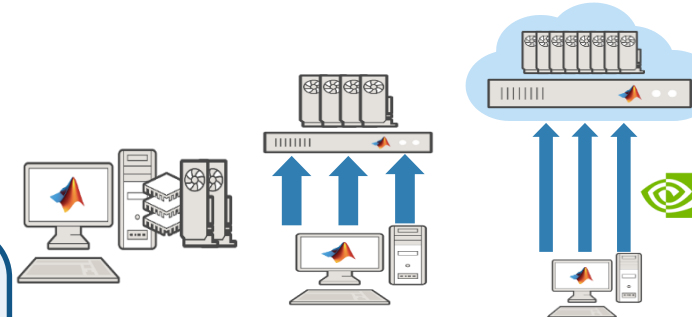

Accelerate Training

**NVIDIA GPU CLOUD**

MATLAB as a container on NGC

## Optimize

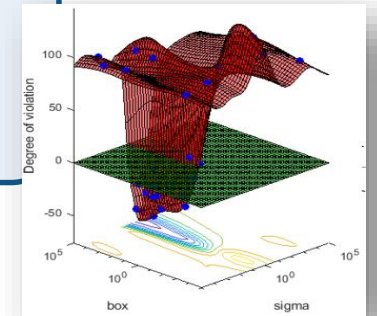

Bayesian Hyperparameter Optimization

# Exchange Models With Deep Learning Frameworks

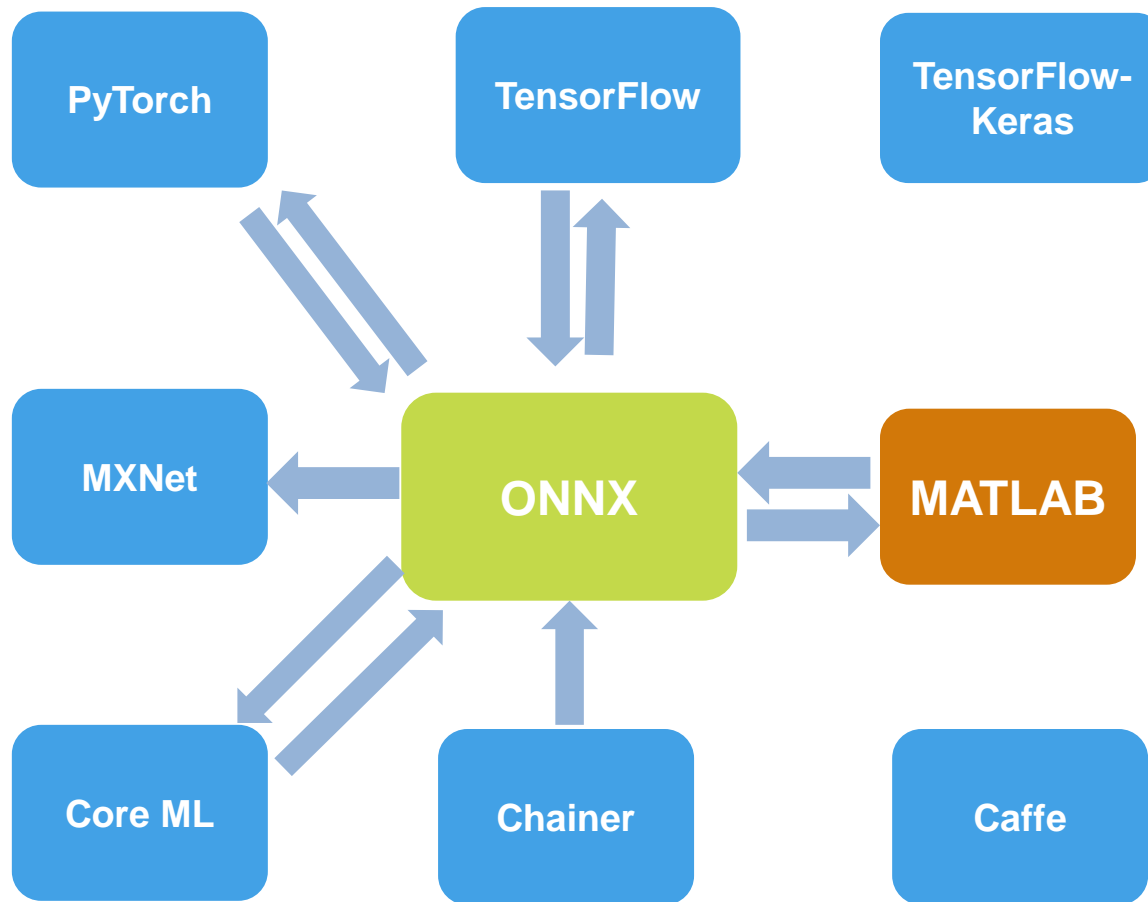

**ONNX = Open Neural Network Exchange Format**

# Exchange Models With Deep Learning Frameworks

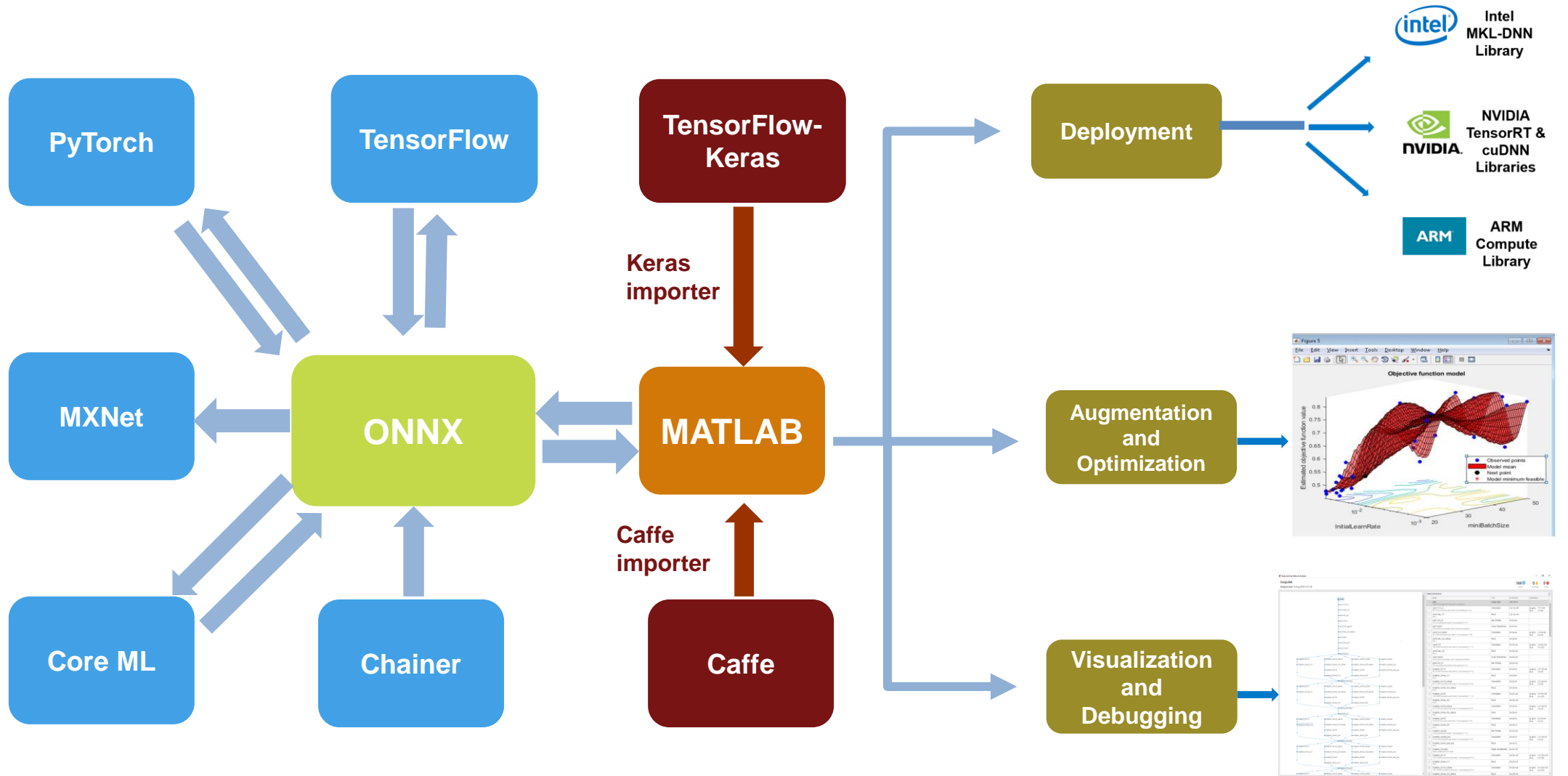

**ONNX = Open Neural Network Exchange Format**

# Agenda

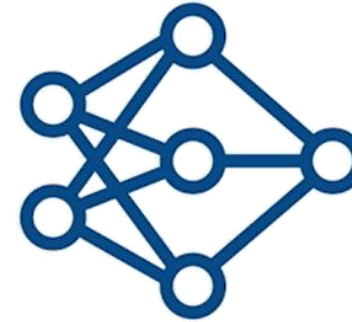

- Deep Learning – Basic ideas
- Deep Learning Model Development for Signals, Time Series, and Text
  - Data
  - Processing and transformation
  - Model design and optimization
  - **Acceleration, prototyping, and deployment**
- Conclusions

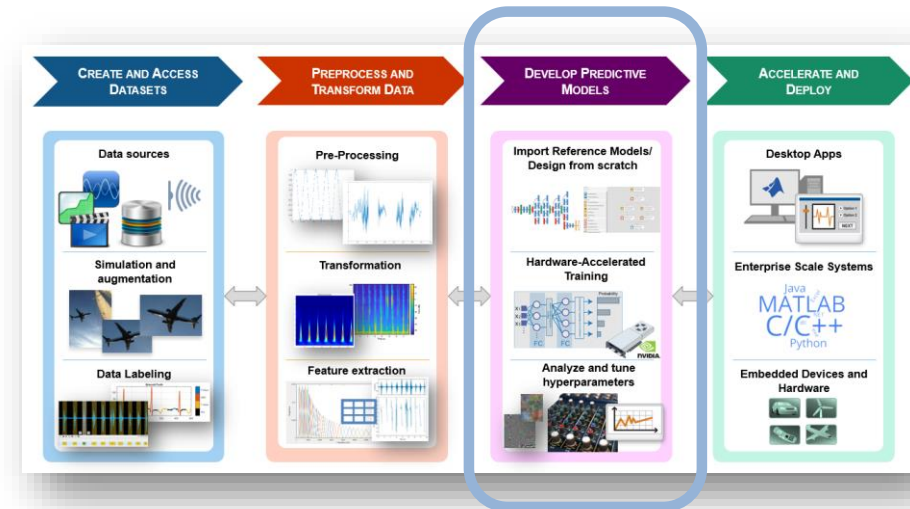



# Deployment and Scaling for A.I.

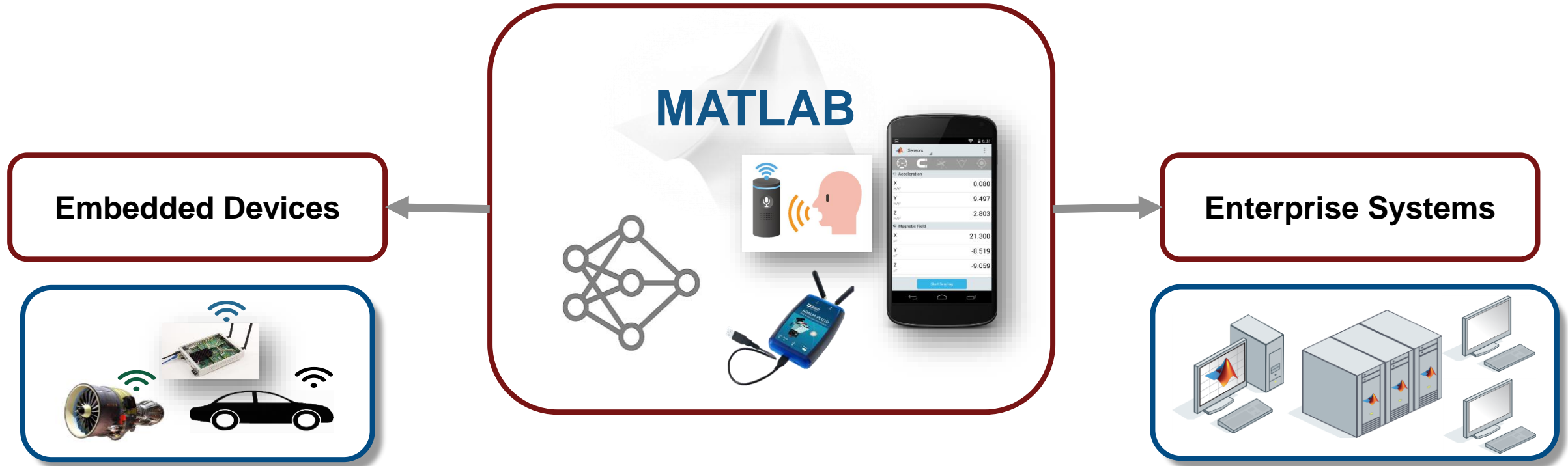

# Deploying Deep Learning Models for Inference

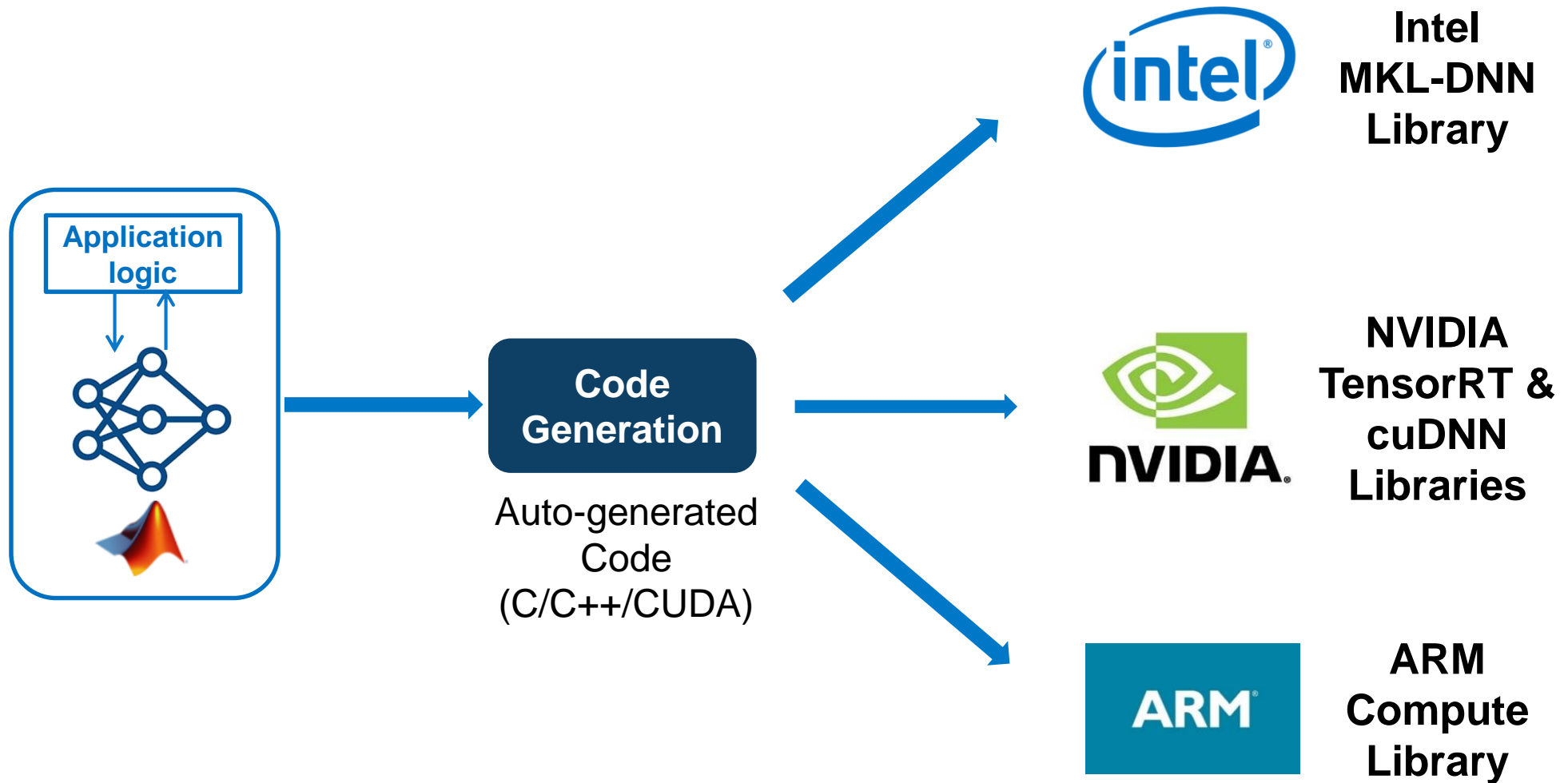

# With GPU Coder, MATLAB is fast

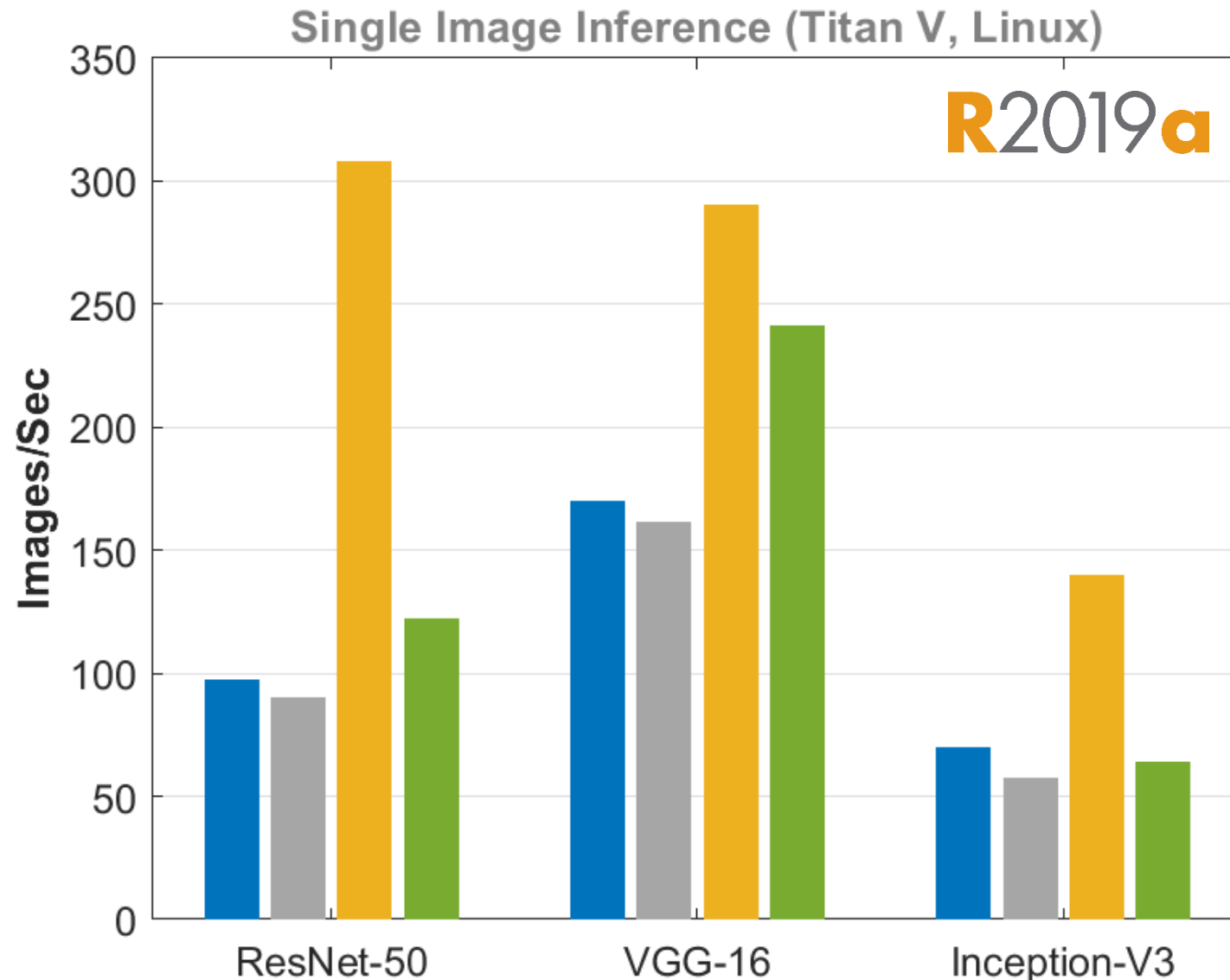

GPU Coder is faster than TensorFlow, MXNet and Pytorch

■ TensorFlow

■ MXNet

■ GPU Coder

■ PyTorch

# Enterprise Deployment

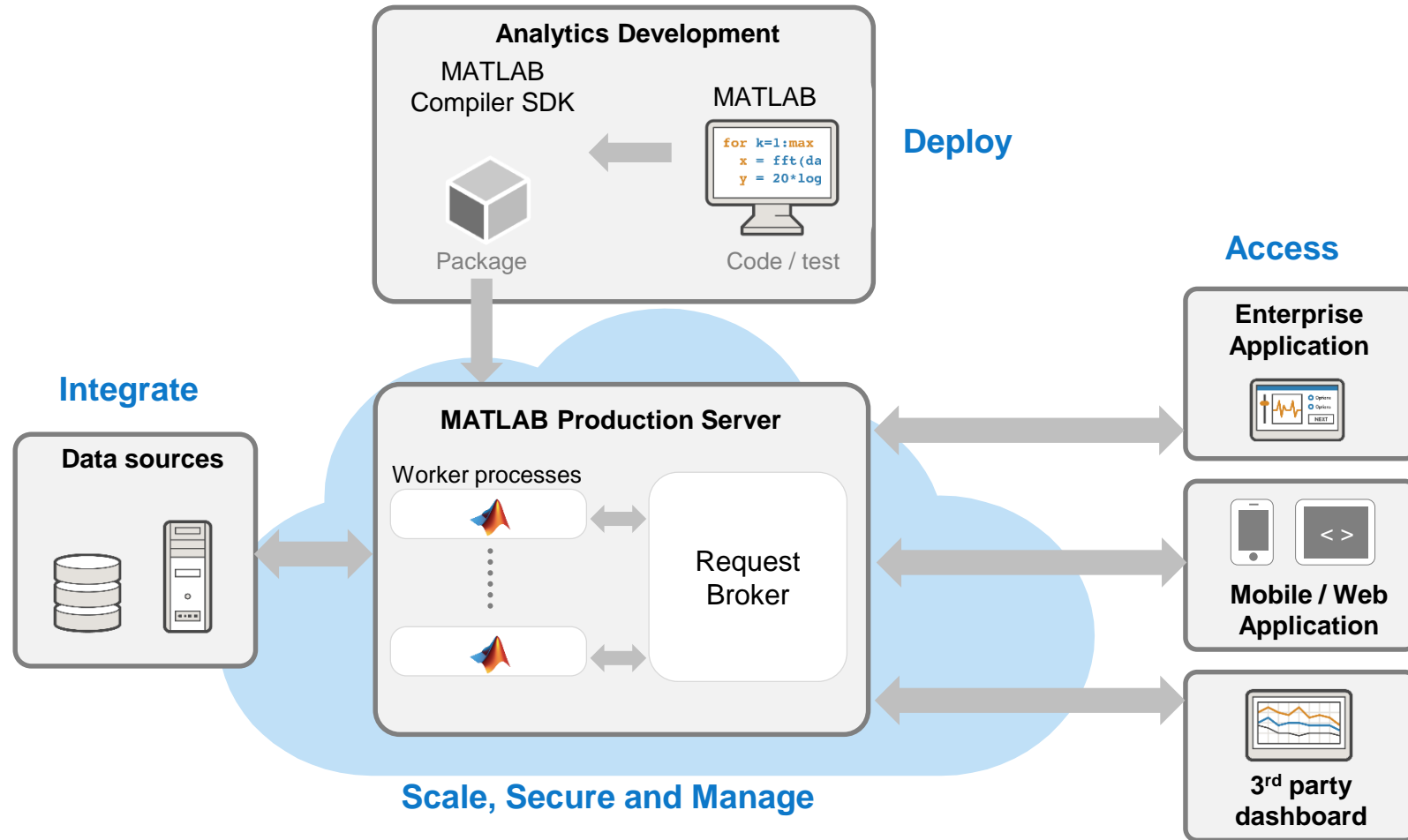

*Deployment to the cloud with MATLAB Compiler and MATLAB Production Server*

# Agenda

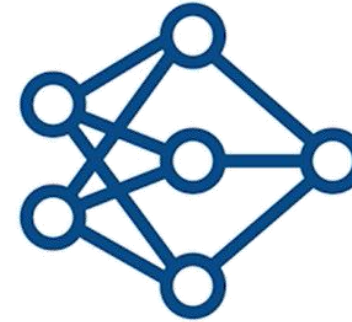

- Deep Learning – Basic ideas
- Deep Learning Model Development for Signals, Time Series, and Text
  - Data
  - Processing and transformation
  - Model design and optimization
  - Acceleration, prototyping, and deployment

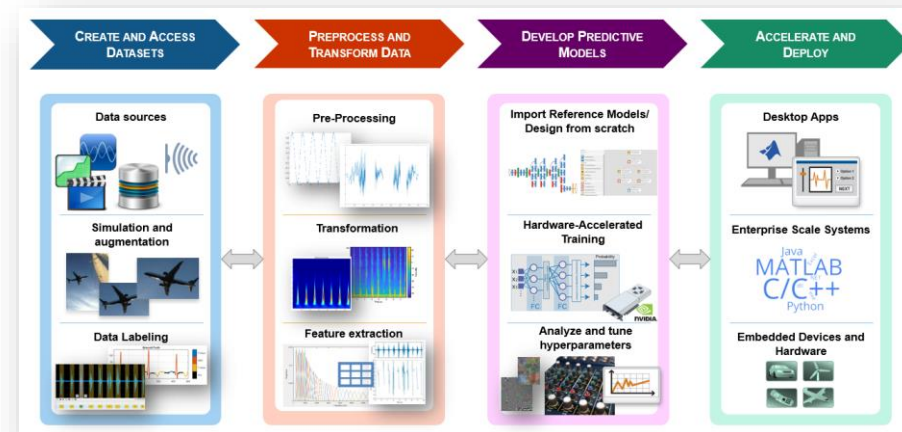

- **Conclusions**

# Deep Learning Workflow Challenges – Signals and Time Series

Deep learning models only as good as training data

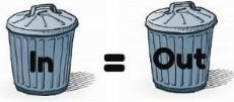

Data-labeling Apps and Examples

Augmentation and simulation algorithms

Deployment and Scaling to various platforms

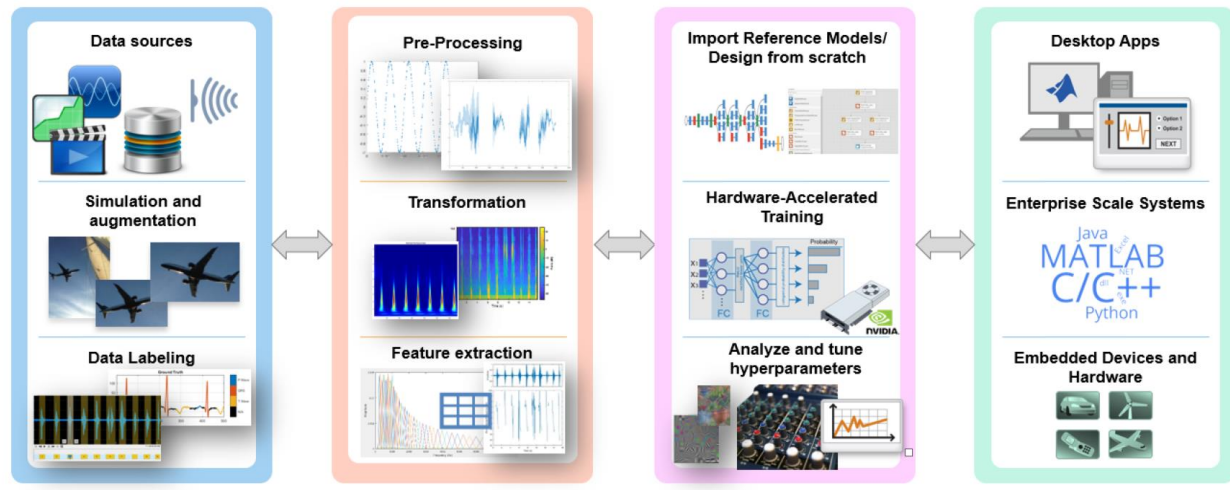
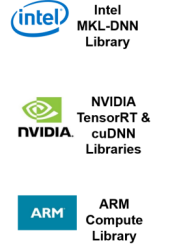

Application-specific algorithms and tools

Collaboration in the AI ecosystem

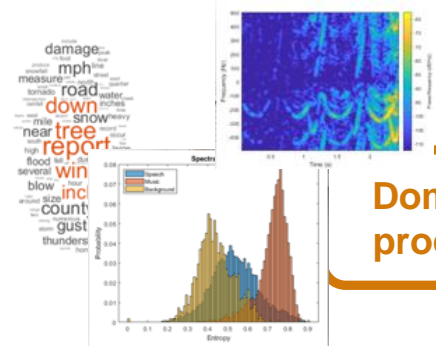
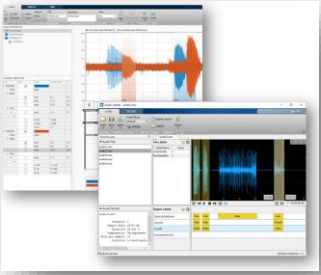
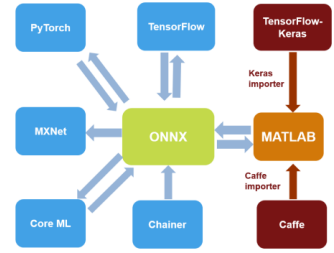

# MATLAB EXPO 2019

데모 부스와 상담부스로 질문 하시기 바랍니다.

## 감사합니다

