



MOTOROLA

MD490 Series

Digital 2.4 GHz
Cordless Telephone System

User's Guide >

Welcome

Congratulations on your purchase of a Motorola product!

Product registration is an important step. Registering helps us facilitate warranty service and permits us to contact you if your Motorola product requires an update or other service.

To register your product online, visit:

www.motorola.com/warranty/cordless

Please retain your original dated sales receipt for your records. For warranty service of your Motorola product, you will need to provide a copy of your dated sales receipt to confirm warranty status. Registration is not required for warranty coverage.

For a large-print version of this guide, or for product-related questions, please call:

1-800-353-2729 in the USA

1-888-390-6456 TTY (Text Telephone)

On the Web:

www.motorola.com/cordless

MOTOROLA and the Stylized M Logo are registered in the US Patent & Trademark Office. All other product or service names are the property of their respective owners. © Motorola, Inc. 2003

6864110W32-A

FCC and Interference Information

This equipment complies with Parts 15 and 68 of the FCC rules and the requirements adopted by the Administrative Council for Terminal Attachments (ACTA).

A plug and jack used to connect this equipment to the premises wiring and telephone network must comply with applicable FCC Part 68 rules and requirements adopted by the ACTA. A compliant telephone cord and modular plug is provided with this product. It is designed to be connected to a compatible modular jack that is also compliant. See installation instructions for details.

Notification of the Local Telephone Company

On the bottom of this equipment is a label that contains, among other information, a product identifier in the form US:AAAEQ##TXXXX. You must, upon request, provide this information to your telephone company.

The digits represented by ## in the product identifier indicate the Ringer Equivalency Number (REN) for this equipment. The REN is useful in determining the number of devices you may connect to your telephone line and still have all of these devices ring when your telephone number is called. In most (but not all) areas, the sum of the RENs of all devices connected to one line should not exceed 5. To be certain of the number of devices you may connect to your line as determined by the REN, contact your local telephone company.

Notes:

- This equipment may not be used on coin service provided by the telephone company.
- Connection to party line service is subject to state tariffs. Contact the state public utility commission, public service commission or corporation commission for information.

- If your home has specially wired alarm equipment connected to the telephone line, ensure the installation of this cordless phone does not disable your alarm equipment. If you have questions about what will disable alarm equipment, consult your telephone company or a qualified installer.
- Notice must be given to the telephone company upon permanent disconnection of your telephone from your line.
- The FCC requires that you connect your cordless telephone to the nationwide telephone network through a modular telephone jack (USOC RJ11C/RJ11W or RJ14C/RJ14W).

Rights of the Telephone Company

Should your equipment cause trouble on your line which may harm the telephone network, the telephone company shall, where practicable, notify you that temporary discontinuance of service may be required. Where prior notice is not practical and the circumstances warrant such action, the telephone company may temporarily disconnect service immediately. In case of such temporary discontinuance, the telephone company must:

1. Promptly notify you of such temporary discontinuance;
2. Afford you the opportunity to correct the situation;
3. Inform you of your right to bring a complaint to the Commission pursuant to procedures set forth in Subpart E of Part 68, FCC Rules and Regulations.

The telephone company may make changes in its facilities, equipment, operations, or procedures that could affect the operation of the equipment. If this happens, the telephone company will provide advance notice in order for you to make necessary modifications to maintain uninterrupted service.

Interference Information

This device complies with Part 15 of the FCC Rules. Operation is subject to the following two conditions:

1. This device may not cause harmful interference.
2. This device must accept any interference received, including interference that may cause undesired operation.

This equipment has been tested and found to comply with the limits for a Class B digital device, pursuant to Part 15 of the FCC Rules. These limits are designed to provide reasonable protection against harmful interference in a residential installation.

This equipment generates, uses, and can radiate radio frequency energy and, if not installed and used in accordance with the instructions, may cause harmful interference to radio communications. However, there is no guarantee that interference will not occur in a particular installation.

If this equipment does cause harmful interference to radio or television reception, which can be determined by turning the equipment on and off, the user is encouraged to try to correct the interference with one or more of the following measures:

Reorient or relocate the receiving antenna (that is, the antenna for the radio or television that is “receiving” the interference).

Reorient or relocate and increase the separation between the telecommunications equipment and the receiving antenna.

Connect the telecommunications equipment into an outlet on a circuit different from that to which the receiving antenna is connected.

If these measures do not eliminate the interference, please consult your dealer or an experienced radio/television technician for additional suggestions. Also, the Federal Communications Commission has prepared a helpful booklet, "How to Identify and Resolve Radio/TV Interference Problems." This booklet is available from the U.S. Government Printing Office, Washington, D.C. 20402. Please specify stock number 004-000-00345-4 when ordering copies.

The FCC requires this product to be serviced only by Motorola or its authorized service agents. Changes or modifications not expressly approved by Motorola could void not only the user's authority to operate the equipment, but also the limited warranty.

Hearing Aid Compatibility

This telephone system meets the FCC standards for hearing aid compatibility.

Important Safety Instructions

Follow these safety precautions when using your cordless phone to reduce the risk of fire, electric shock, and injury to persons or property:

1. Keep all slits and openings of the phone unblocked. Do not set the phone on a heating register or over a radiator. Ensure that proper ventilation is provided at the installation site.
2. Do not use while wet or while standing in water.
3. Do not use this product near water (for example, near a bath tub, kitchen sink, or swimming pool).
4. Do not allow anything to rest on the power cord. Place the power cord so that it will not be walked on.
5. Never insert objects of any kind into the product slits as that may result in fire or shock.
6. Unplug this product from the wall outlet before cleaning. Do not use liquid cleaners or aerosol cleaners. Use a damp cloth for cleaning.
7. Do not disassemble this product. If service or repair work is required, contact the Motorola address found in the back of this user's guide.
8. Do not overload wall outlets and extension cords.
9. Avoid using during an electrical storm. Use a surge protector to protect the equipment.
10. Do not use this cordless phone to report a gas leak, especially if you are in the vicinity of the gas line.

Caution: To reduce the risk of fire, use only No. 26 AWG or larger UL Listed or CSA Certified Telecommunication Line Cord.

Unplug this cordless phone immediately from an outlet if:

- The power cord or plug is damaged or frayed.
- Liquid has been spilled into the product.
- The product has been exposed to rain or water. Do not retrieve the handset or base until after you have unplugged the power and phone from the wall. Then retrieve the unit by the unplugged cords.
- The product has been dropped or the cabinet has been damaged.
- The product exhibits a distinct change in performance.

Installation Guidelines

1. Read and understand all instructions and save them for future reference.
2. Follow all warnings and instructions marked on the product.
3. Do not install this product near a bath tub, sink, or shower.
4. Operate this phone using only the power source that is indicated on the marking label. If you are unsure of the power supply to your home, consult with your dealer or local power company.
5. Do not place this product on an unstable cart, stand, or table. This product may fall, causing serious damage to the product.
6. Adjust only those controls that are covered by the operating instructions. Improper adjustment of other controls may result in damage and will often require extensive work to restore the product to normal operation.
7. Clean this product with a soft, damp cloth. Do not use chemicals or cleaning agents to clean this phone.

8. Use only the power supply that came with this unit. Using other power supplies may damage the unit.
9. Because cordless phones operate on electricity, you should have at least one phone in your home that is not cordless in case the power in your home goes out.
10. To avoid interference to nearby appliances, do not place the base of the cordless phone on or near a TV, microwave oven, or VCR.

Caution: To maintain compliance with the FCC's RF exposure guidelines, place the base unit at least 20 cm from nearby persons.

Battery Safety Instructions

- Do not burn, disassemble, mutilate, or puncture the battery. The battery contains toxic materials that could be released, resulting in injury.
- **Caution:** There is a risk of explosion if you replace the battery with an incorrect battery type. Use only the battery that came with your phone or an authorized replacement recommended by the manufacturer.
- Keep batteries out of the reach of children.
- Remove batteries if storing over 30 days.
- Do not dispose of batteries in fire, which could result in explosion.
- The rechargeable batteries that power this product must be disposed of properly and may need to be recycled. Refer to your battery's label for battery type. Contact your local recycling center for proper disposal methods.



Contents

Welcome	1
FCC and Interference Information	2
Important Safety Instructions	6
Getting Started	12
Powering the Base Station and Phone Line Connection	13
Wall Mounting the Base Station	14
Base Station Controls	16
Expansion Handset Controls	16
Using the Soft Keys	16
Using the Navigation Key	17
Using the Displays	17
Base Station Display	17
Expansion Handset Display	18
Setting Up Your Phone and Expansion Handsets ...	19
Installing Batteries in the Handsets	19
Charging the Expansion Handsets	20
Registering an Expansion Handset	20
Personalizing Your Phone System	21
Setting the Ring Tone and Ring Volume	21
Setting Key Beeps On or Off	22
Naming the Base Station or Expansion Handset	23
Entering Text	24
Storing Area Codes for Caller ID	24
Setting the Date and Time	26
Setting the Display Language	27
Setting Touch Tone or Pulse Dialing	27

Using the Basic Functions	28
Making a Call Using the Base Station	28
Making a Call Using the Speakerphone on the Base Station	28
Adjusting the Speakerphone Volume on the Base Station During a Call	29
Making a Call Using an Expansion Handset	29
Adjusting the Volume During a Call on the Expansion Handset	30
Switching Between the Handset and Speakerphone	30
Muting a Call	30
Putting a Call on Hold	30
Redialing a Number	30
Finding a Lost or Misplaced Handset	31
Saving a Number in the Phonebook	31
Private Phonebooks	32
Shared Phonebooks	32
Sorting Phonebooks	33
Calling a Number from the Phonebook	34
Editing a Phonebook Entry	35
Deleting a Phonebook Entry	35
Inserting Pauses in a Number	36
Automated Dialing	36
Using Caller ID	37
Reviewing the List of Caller ID Calls	37
Store a Caller ID Number in the Phonebook	38
Deleting Caller ID Calls	38
Answering Machine	39
Setting Up the Answering Machine	39
Turning the Answering Machine On or Off	39
Outgoing Message (OGM) Greeting	40

Recording an Outgoing Message (OGM)	40
Changing the Outgoing Message	40
Erasing the Outgoing Message	41
Setting the Number of Rings Before the Answering Machine Picks Up	41
Using Call Screening	42
Setting the Security ID Number	42
Recording a Memo	43
Using the Answer Machine	43
Checking Messages from the Base Station	43
Checking Messages from an Expansion Handset	44
Checking Messages Remotely from a Touch-Tone Phone	45
Advanced Features	47
Conference Calling	48
Using the Intercom	48
Intercom Setup	48
Handset to Handset Intercom	49
Transferring a Call from One Handset to Another . . .	50
Unannounced Transfer	50
Announced Transfer	51
Using the Handset as a Walkie Talkie	52
Monitoring a Room	53
Deregistering All Expansion Handsets	54
Motorola Limited Warranty for the United States and Canada	55

Getting Started

To set up your Motorola digital cordless phone system:

- 1 Install optional backup batteries in the base station, plug into a power outlet, and connect to phone line (see page 13).
- 2 Plug in charging bases and install batteries in expansion handsets (see page 19).
- 3 Charge expansion handset batteries (see page 20).

A rechargeable NiCd battery powers each expansion handset. Charge the battery for about 12 hours before initial use.

- 4 Register expansion handsets to the base station (see page 20).
- 5 Set the ring tone, date, time, and other features of your expansion handset(s) and base station (see page 21).

Place the Base Station:

- Away from electrical appliances such as a TV, personal computer, or another cordless phone.
- In a high and central location with no obstructions, such as walls.

If you hear noise while using the handset near a microwave or another cordless phone's base unit, move away from the microwave or base unit and closer to your handset's base station.

Powering the Base Station and Phone Line Connection

Important: Before installing or handling batteries, please read the “Battery Safety Instructions” on page 8.

The base station uses 4 AAA alkaline batteries for optional backup power. To install the batteries:

- 1 With the bottom of the base station facing you, press the cover latch with a screwdriver to lift and remove the battery cover.
- 2 Insert 4 AAA alkaline batteries into the battery compartment.

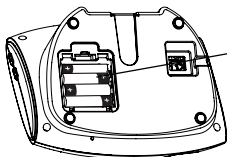

Battery compartment
(cover removed)

- 3 To replace the cover, insert the tabs of the cover into the slots and press down until the cover clicks into place.
- 4 Plug the power cord into the back of the base station and into an outlet.
- 5 Plug one end of the telephone line cord into the jack on the bottom of the base station.

- 6 Plug the other end of the cord into the phone jack.

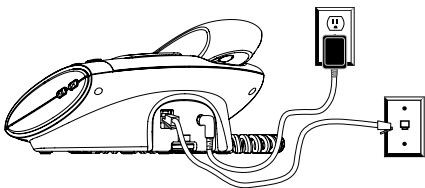

Wall Mounting the Base Station

The base station can be mounted on a wall instead of placed on a flat surface.

- 1 Remove the twist-tie from the phone cord. Do not unfold the cord.

- 2 Untuck both ends of the cord.

- 3 Hold the folded cord at the center and insert it into the back of the wall mount bracket.

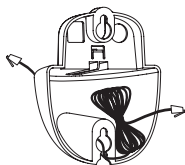

- 4 Plug the telephone cord into the phone jack on the wall.

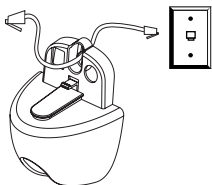

- 5 Hang the wall mount bracket on the phone wall plate.

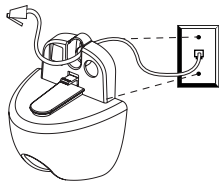

- 6 Plug the other end of the telephone cord into the back of the base station

- 7 Plug the power cord into a power outlet, if not already plugged in.

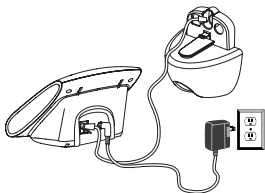

- 8 Insert the guide rail on the wall mount into the slot on the bottom of the base station and push until it snaps into place.

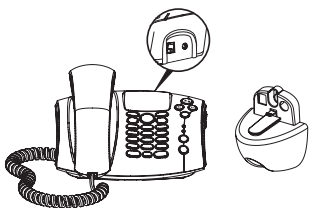

Note: To separate wall mount from base, press down on the middle clasp of the bracket and pull out.

Base Station Controls

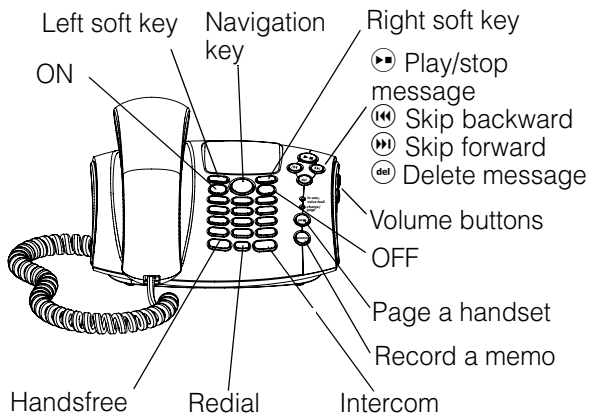

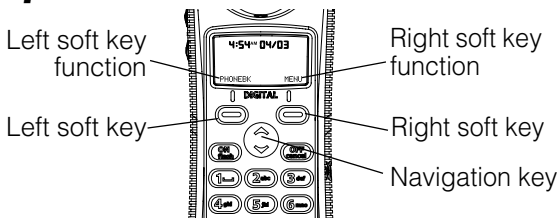

Expansion Handset Controls





Using the Soft Keys

The left and right soft keys on the base station and expansion handsets perform the function displayed above them. For example, pressing the left soft key while **PHONEBK** is displayed, opens your list of phone numbers and names. The functions change as you

move from one screen to the next. In this guide, soft key functions are shown as the function name followed by , for example, press **CHANGE** ()

Using the Navigation Key

 is used to scroll up and down through menu items, a list of settings, and other screens.

On expansion handsets,  points to the currently selected item, and 

indicates there are more items above and below the currently selected item.

Press  to scroll up or down on the display.

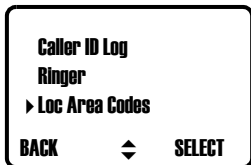

Using the Displays

Your phone has a display on the base station. Expansion handsets have a display on the front of them. The base station and expansion handsets, when not in use, show the **standby screen**.

Base Station Display

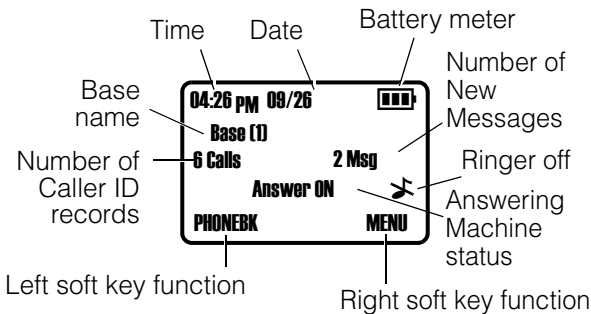

Expansion Handset Display

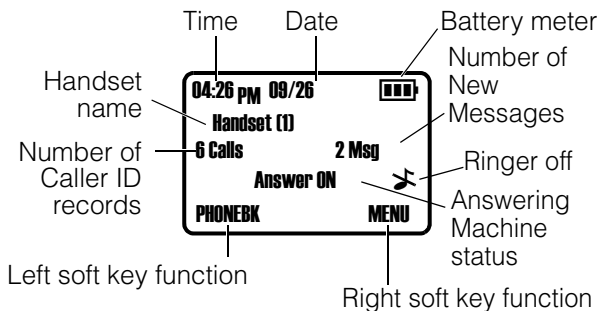

Setting Up Your Phone and Expansion Handsets

If you have expansion handsets, they do not need to be plugged into a phone line. Simply plug the power cord into the back of the charging base and into an outlet wherever you want to place the handset.

Installing Batteries in the Handsets

Important: Before installing or handling batteries, read the Battery Safety Instructions on page 8.

- 1 Remove the battery cover by pressing on the recess and sliding down and off the handset.
- 2 Plug the connector into the receptacle.
- 3 Insert the battery pack into the compartment.
- 4 Slide and snap the battery cover back into place.

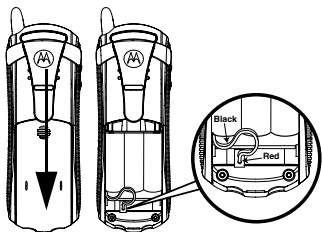

Charging the Expansion Handsets

Place the handset in the charging base. The charging LED is solid red when the handset is charging.

For the initial charge, charge the battery for at least 12 hours.



Registering an Expansion Handset

You can have up to 4 expansion handsets registered to a base station. If you try to register a 5th handset, **Too Many Handsets** displays.

You only need to register new accessory handsets you add to your phone system. To register a new handset:

Action

- 1 Press **OK** ().
- 2 Press and hold **PAGE** on the base station for at least 6 seconds or until you hear a long beep and see the expansion handset name, for example, **Handset(2)**.

Personalizing Your Phone System

You can personalize the base station and each expansion handset by setting unique ring tones, adjusting the ring tone volume for day and night time, and assigning a name to distinguish 1 handset from another.

Setting the Ring Tone and Ring Volume

Your can set a ring tone for incoming calls from numbers that are stored in the phonebook, and a different ring tone for other incoming calls. The phonebook ring tone works only if you subscribe to caller ID service from your local telephone company.

Action

- 1 Press **MENU** (☰).
- 2 Scroll to **Ringer** and press **SELECT** (☰).
- 3 The Day Volume displays. This is the ringer volume from 6 am to 9 pm. Press **CHANGE** (☰) to scroll through the settings (off, low, medium, high). Each volume level plays as you press **CHANGE** (☰). Stop at the volume level you want to set.
- 4 Scroll down (⏴) to advance to the Night Volume. This is the ringer volume from 9 pm to 6 am. Press **CHANGE** (☰) to scroll through the settings. Each volume level plays as you press **CHANGE** (☰). Stop at the volume level you want to set.
- 5 Scroll down (⏴) to advance to the Ring Tone. This is the ring sound used for incoming calls.

Action

- 6 Press **CHANGE** (≡) to scroll through the ring tones. Each tone plays as you select **CHANGE** (≡). Stop at the ring tone you want to set, then press **DONE** (≡).
- 7 Scroll down (⏴) to advance to the Phonebook Tone. This is the sound for incoming calls from numbers stored in your phonebook. You must subscribe to caller ID service from your local telephone company for this ring tone to work. Press **DONE** (≡) to confirm.
- 8 Press **CHANGE** (≡) to scroll through the phonebook tones. Each tone plays as you select **CHANGE** (≡). Stop at the phonebook tone you want to set.
- 9 Press **DONE** (≡).
- 10 Press **EXIT** (≡) to return to the standby screen, or (⏴) to scroll to a different menu option.

Setting Key Beeps On or Off

You can turn on or off the key beeps on the base station and each handset.

Action

- 1 Press **MENU** (≡).
- 2 Scroll to **Ringer** and press **SELECT** (≡).

Action

- 3 Scroll to **Key Beeps** and press **SELECT** (⏏).
- 4 Press **CHANGE** (⏏) to scroll through the selections. When your choice (**ON**, **OFF**, or **LINKED to RINGER**) display, press **SELECT** (⏏).

Note: When set to **LINKED to RINGER**, key beeps are on when the ringer is set to on, and off when the ringer is set to off.

Naming the Base Station or Expansion Handset

When you register an expansion handset, it is assigned a default name of **Handset(x)**, where *x* can be 1, 2, 3, or 4. You can change the name to something more useful, for example a location (**Kitchen**) or someone's name (**Susan**). Naming an expansion handset makes it easy to select the handset from a list (for example, to intercom another handset).

If you name an expansion handset, the handset number remains part of the name, for example, **Kitchen(2)**.

Action

- 1 Press **MENU** (⏏).
- 2 Scroll to **Name handset** or **Name base**, then press **SELECT** (⏏).
- 3 Use the keypad to enter the new name (up to 12 characters). The flashing underline shows the input cursor position. Press **DELETE** (⏏) to backspace and erase characters to the left of the input cursor, see "Entering Text" on page 24.

Action

- 4 Press **DONE** (⏏).
- 5 Press **EXIT** (⏏) to return to the standby screen, or (⌂) to scroll to a different menu option.

Entering Text

Press each button on the keypad the indicated number of times shown in the table below to enter text, numbers, and other characters. For example, to enter R, press the 7 button 3 times.

Button	Number of Presses				
	1	2	3	4	5
1	space	-	*	,	1
2	A	B	C	(2
3	D	E	F)	3
4	G	H	I	#	4
5	J	K	L	/	5
6	M	N	O	'	6
7	P	Q	R	S	7
8	T	U	V	?	8
9	W	X	Y	Z	9

Storing Area Codes for Caller ID

Note: This section applies only if you subscribe to caller ID service from your local phone company.

You can store up to 5 area codes to make it easy to dial numbers from your list of caller ID calls. Each area code can be:

- **7-digit format**

You do not have to dial the area code to call numbers in this area code.

- **10-digit format**

You have to dial the 3-digit area code + 7-digit phone number to call numbers in this area code.

- **11-digit format**

You have to dial the 1 + 3-digit area code + 7-digit phone number to call numbers in this area code.

For example, if you store area code *954* in 10-digit format, when you receive a call from that area code, the phone number is stored in your call list with all 10 digits. The number will then be in the correct format for you to dial directly from the call list without any reformatting.

Action

- 1 Press **MENU** (≡).
- 2 Scroll to **Loc area code** and press **SELECT** (≡).
- 3 Enter the first area code.
- 4 Press **FORMAT** (≡) to scroll through the formats. Stop at the format you want to set for the area code, then scroll down (⌵) to move to the next area code.
- 5 Repeat steps 3 and 4 to store up to 4 more area codes. When you are finished, press **DONE** (≡).
- 6 Press **EXIT** (≡) to return to the standby screen, or ⌵ to scroll to a different menu option.

Setting the Date and Time

Note: If you subscribe to a caller ID service, the date and time is automatically set after the 2nd ring on an incoming call.

Action	
1	Press MENU (≡).
2	Scroll to Date/Time and press SELECT (≡).
3	Enter the time. (2 digits are required for both the hour and the minutes, so use a leading 0 for 1-digit values.)
4	If using a 12-hour clock, press AM/PM (≡) to switch between am and pm .
5	Scroll down (⏴) to the next field.
6	Press CHANGE (≡) to change the time format (12- or 24-hour clock). Scroll down (⏴) to the next field.
7	Press CHANGE (≡) to select date format (MM/DD or DD/MM).
8	Scroll down (⏴) to the next field.
9	Enter the current date.
10	Press DONE (≡).
11	Press EXIT (≡) to return to the standby screen or (⏴) to scroll to a different menu option.

Setting the Display Language

Action

- 1 Press **MENU** (≡).
- 2 Scroll to **Language** and press **SELECT** (≡).
- 3 Press ⤴ until ▶ points to the language you want to set (**English, French, Spanish, or Portuguese**).
- 4 Press **DONE** (≡).
- 5 Press **EXIT** (≡) to return to the standby screen or ⤴ to scroll to a different menu option.

Setting Touch Tone or Pulse Dialing

Your phone is set to touch-tone dialing as the default setting. Do not change this setting unless touch-tone service is not available in your area.

Action

- 1 Press **MENU** (≡).
- 2 Scroll to **Tone/Pulse**.
- 3 Press ⤴ or **CHANGE** (≡) to switch between **Tone** and **Pulse**.
- 4 Press **DONE** (≡).
- 5 Press **EXIT** (≡) to return to the standby screen or ⤴ to scroll to a different menu option.

Using the Basic Functions

Making a Call Using the Base Station

Pickup the corded handset or press **ON**. When you hear the dial tone, dial the number.

or

Enter the phone number, press **ON**, then pickup the handset. This lets you see the phone number on the display before the number is dialed.

During a call, a timer on the display shows the amount of time on the call.

When you are finished talking, place the handset back on the base station, or press **OFF** to hang up.

Press **ON** or **Handsfree** to answer a call using the speakerphone.

If you have call waiting service, press **ON** to answer a second call.

Making a Call Using the Speakerphone on the Base Station

Press **Handsfree**, then dial the number.

When the speakerphone is on, **«»** appears on the display.

When you are finished talking, press **OFF** to hang up and turn the speakerphone off.

Note: Pressing **Handsfree** while in the caller ID list, redial list, or phonebook turns the speakerphone on and dials the number.

If you have call waiting service, press **ON** to answer the second call.

Adjusting the Speakerphone Volume on the Base Station During a Call

Press the volume up or volume down key on the side of the base station.

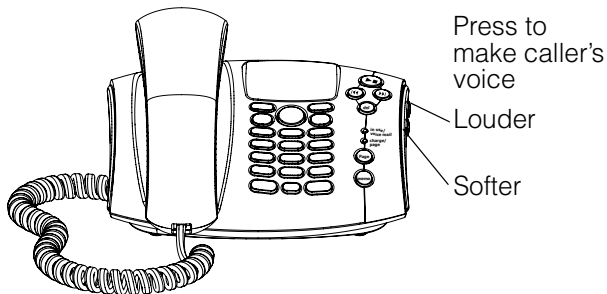

When you are not on a call, use the volume keys to change the day (6 am–9 pm) or night (9 pm–6 am) ringer volume. The time of day as set on the phone determines whether you are adjusting the day or night volume. To set the time, see page 26.

Making a Call Using an Expansion Handset

The procedure for making a call using an expansion handset is the same as for making one from the base station. However, when you dial from the base station, you can use it in speakerphone mode and by picking up the handset.

Adjusting the Volume During a Call on the Expansion Handset

Press to
make caller's
voice:

Louder

Softer

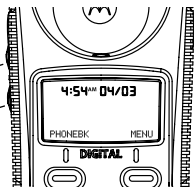

Switching Between the Handset and Speakerphone

Press **Handsfree** to toggle between handset and speakerphone.

Muting a Call

Press **MUTE** (☎).

To unmute the call, press **UNMUTE** (☎).

Putting a Call on Hold

Press **HOLD** (☎).

To return to the call, press **UNHOLD** (☎) or **ON**.

When a call is on hold, you can use the intercom features (see page 49).



Redialing a Number

To redial the most recently dialed number:

Action
1 Press ON .
2 Press Redial .

To redial one of the last 5 numbers you dialed:

Action



- 1 Press **Redial**.
- 2 Press  until  points to the number you want to redial.
- 3 Press **Dial** () , **ON** or **Handsfree**.

If a number in the redial list matches a number in your phonebook, the phonebook name and number display in the redial list instead of just the phone number.

Finding a Lost or Misplaced Handset

Press **PAGE** on the base station.

All handsets registered to the base station start beeping.

Press **OFF** or **EXIT** () to stop paging all handsets, or **OK** () on the expansion handset to stop paging that individual handset. You can also press **PAGE** on the base station to stop paging all handsets simultaneously.

Saving a Number in the Phonebook

Storing numbers in the phonebook makes it easy to dial numbers you call frequently. You can enter numbers directly into the phonebook or add them from the caller ID or redial list. You can also select to save the number in the private (handsets) or shared (base station) phonebook.

Private Phonebooks





The private phonebook is unique to each handset and is not accessible by other handsets or the base station. Each private phonebook stores up to 50 names and numbers.

Shared Phonebooks

The shared phonebook is stored in the base station and is accessible by all handsets. The shared phonebook stores up to 49 names and numbers.

Action

- 1 Press **PHONEBK** () .

- 2 Scroll () to **(New Entry)** and press **SELECT** () .
 The private phonebook is the default. To change phonebooks, press the right soft key () . For example, if **SHARED** is displayed, press the right soft key () to enter that phonebook.

- 3 Enter the name (up to 12 characters). Press **DELETE** () to backspace and erase characters to the left of the blinking cursor. See page 24 for information on entering text.







- 4 Scroll down () .

- 5 Enter the phone number (up to 24 digits). Press **DELETE** () to backspace and erase characters to the left of the blinking cursor.

- 6 Press **DONE** () .

To store a recently called number in the phonebook:

Action

- 1 Press **Redial**. The display shows the last 5 numbers you dialed, with the most recent number at the top.
- 2 Press  until  points to the number you want to save.
- 3 Press **STORE** ().
- 4 Enter the name (up to 12 characters). Press **DELETE** () to backspace and erase characters to the left of the blinking cursor. See page 24 for information on entering text.
- 5 Scroll down ().
- 6 The phone number displays in the **Number:** field. To modify the number, press **DELETE** () to backspace and erase characters to the left of the blinking cursor.
- 7 When the phone number is correct as you want to store it, press **DONE** ().

Note: You can also store a number in the phonebook from the caller ID list (see page 38).

Sorting Phonebooks

The private and shared phonebooks can be sorted alphabetically and independently of each other. Once sorted, a phonebook cannot be unsorted or reset to its previous list order.

Note: The shared phonebook can only be sorted from the base station.

Action	
1	Press PHONEBK (☐).
2	Scroll to any phonebook entry.
3	Press OPTIONS (☐).
4	Scroll to SORT PHONEBK .
5	Press SELECT (☐). ALPHABETICALLY SORT PHONEBK? displays.
6	Press YES (☐) or NO (☐).
7	Press OFF to return to the standby screen.

Calling a Number from the Phonebook

Action	
1	Press PHONEBK (☐).
2	Press ⏴ until ▶ points to the entry you want to call. Note: You can also search numerically by pressing the number(s) of the phone entry you want to dial.
3	Press ON , Handsfree , or pickup the corded handset on the base.

Editing a Phonebook Entry

When editing a phonebook entry, you can change upper case letters to lower case letters.

Action



- 1 Press **PHONEBK** (☎).
- 2 Press (⌂) until ▶ points to the entry you want to edit.
- 3 Press **OPTIONS** (☎).
- 4 Scroll to **Edit** and press **SELECT** (☎).
- 5 To modify the name, press **DELETE** (☎) to backspace and erase characters to the left of the blinking cursor. See page 24 for information on entering text.
Note: The first letter of the entry is an uppercase letter. To change the entry from upper case to lowercase, press *. A flashing square indicates that you are in the upper case text entry mode. A flashing _ indicates that you are in the lowercase text entry mode.
- 6 Scroll down (⏴) to move to the phone number field.
- 7 Modify the number.
- 8 Press **DONE** (☎).

Deleting a Phonebook Entry

Action

- 1 Press **PHONEBK** (☎).

Action

- 2 Press  until  points to the entry you want to delete.

- 3 Press **OPTIONS** ().

- 4 Scroll to **Delete** and press **SELECT** ().



Inserting Pauses in a Number

At the position where you want to insert a pause, press # twice. **P** appears. When you call a number with a pause, the phone waits 3 seconds before transmitting the next digits in the dialing sequence. This is useful, for example, when you have to dial 9 to get a dial tone or for going into a voicemail system.

Automated Dialing

You can retrieve previously entered information from the phonebook (such as PIN or credit card number) during a phone call without having to re-enter the numbers.

Action

- 1 While on a call, press  until  points to the entry you want to recall.

- 2 Press **DIAL** ().

- 3 Repeat steps 1 and 2 as many times as necessary to complete your transaction.

Note: This function is useful when using automated response systems. For example, you could access your bank account by dialing the bank's telephone number, entering your account number (using

automated dialing), and PIN (using automated dialing). Then, you can enter your most frequently used prompt, for example balance inquiry.

Using Caller ID

Note: You must subscribe to caller ID service from your local telephone company to use the caller ID features of your phone.

If you subscribe to caller ID service, the caller's name and/or number are displayed when you receive an incoming call.

If no caller ID information was sent from the phone company, or you do not subscribe to caller ID service, the display shows **Incoming Call**.

Reviewing the List of Caller ID Calls



The base station and each expansion handset can hold up to 40 caller ID records.

Action

- 1 Press  to enter the recent calls list. The most recent call is listed first.

- 2 Press  to review more calls.

- 3 To call the number, press **ON** or **Handsfree**.

To reformat the number before you call it, press **FORMAT** () until the correct format displays. For example, if a number you want to call is stored with the area code (10 digits), but you do not use the area code to call this number, press **FORMAT** () until the number appears without the area code (7 digits). For information on dialing formats, see page 24.

Store a Caller ID Number in the Phonebook

Action	
1	From the caller ID list, press OPTIONS (≡).
2	Scroll to STORE and press SELECT (≡).
3	The caller's name displays in the Name: field. You can modify the name before storing it.
4	When the name is correct as you want to store it, press ⏴ to scroll down.
5	The caller's phone number displays in the Number: field. You can modify the number before storing it.
6	When number is correct as you want to store it, press DONE (≡).

Note: To modify the name or number before storing it, press **DELETE** (≡) to backspace and erase characters to the left of the blinking cursor. Then use the keypad to enter the name or number. See page 24 for information on entering text.

Deleting Caller ID Calls

Action	
1	From the caller ID list, press OPTIONS (≡).
2	Scroll to Delete (to delete the current caller ID entry) or Delete All (to delete all caller ID calls) and press SELECT (≡).
	Note: If deleting all calls, press YES (≡) at the Delete All? prompt.
3	Press NO (≡) to return to the caller ID list.

Answering Machine

The answering machine stores up to 15 minutes of messages and/or memos. You can listen to your messages from the base station, from an expansion handset, or remotely. You can set up the answering machine from an expansion handset or the base station.

Setting Up the Answering Machine

All answering machine features are in the **Ans mach setup** menu. To get to this menu:

Action

- 1 From the standby screen, press **MENU** (≡).
 - 2 Scroll (⊙) to **Ans mach setup** and press **SELECT** (≡).
-

Turning the Answering Machine On or Off

Action

- 1 Go to the **Ans mach setup** menu.
 - 2 Scroll to **Answer ON/OFF** and press **SELECT** (≡).
 - 3 Scroll to select **ON** or **OFF** and press **DONE** (≡).
 - 4 Press **EXIT** (≡) twice to return to the standby screen, or press (⊙) to scroll to a different function.
-

Outgoing Message (OGM) Greeting

You can record a personal outgoing message greeting that plays when you receive a call and do not answer. If you do not record a personal greeting, a prerecorded greeting plays when you receive a call.

Recording an Outgoing Message (OGM)

Action

- 1 Go to the **Ans mach setup** menu.
- 2 Scroll to **Outgoing Msg** and press **SELECT** (⏎).
- 3 Scroll to **Record OGM** and press **SELECT** (⏎).
- 4 Press **YES** (⏎) to record your message.
- 5 Press **END** (⏎) when finished. Press **REPLAY** (⏎) to listen to the message.
- 6 Press **EXIT** (⏎) twice to return to the standby screen, or press ⏪ to scroll to a different feature.

Changing the Outgoing Message

Action

- 1 Go to the **Ans mach setup** menu.
- 2 Scroll to **Outgoing Msg** and press **SELECT** (⏎).
- 3 Scroll to **Change OGM** and press **SELECT** (⏎).
- 4 Scroll to **Default OGM** or **Recorded OGM** and press **SELECT** (⏎).

Action

- 5 Press **EXIT** (⏪) twice to return to the standby screen, or press ⏵ to scroll to a different feature.
-

Note: To play the current outgoing message, select **Play OGM** from the **Outgoing Msg** menu.

Erasing the Outgoing Message

Note: You cannot erase the default message.

Action

- 1 Go to the **Ans mach setup** menu.
 - 2 Scroll to **Outgoing Msg** and press **SELECT** (⏪).
 - 3 Scroll to **Erase OGM** and press **SELECT** (⏪).
 - 4 Press **YES** (⏪).
 - 5 Press **EXIT** (⏪) twice to return to the standby screen, or press ⏵ to scroll to a different feature.
-

Note: To play the current outgoing message, select **Play OGM** from the **Outgoing Msg** menu.

Setting the Number of Rings Before the Answering Machine Picks Up**Action**

- 1 Go to the **Ans mach setup** menu.
 - 2 Scroll to **Ring Number** and press **SELECT** (⏪).
-

Action

- 3 Scroll (⤴) to select 3, 4, 5, or 6 rings and press **DONE** (⏻).
- 4 Press **EXIT** (⏻) twice to return to the standby screen or (⤴) to scroll to a different feature.

Using Call Screening

You can screen incoming calls so you can decide to answer the call or allow the answering machine to answer the call.

Action

- 1 When **RECORDING INCOMING MESSAGE** displays, press **SCREEN** (⏻) to hear the caller without answering.
- 2 Press **ON** to answer the call, or press **OFF** to cancel call screening.

Setting the Security ID Number

The security ID number allows you to remotely access your messages from any touch-tone phone. The default ID is 123. To change it:

Action

- 1 Go to the **Ans mach setup** menu.

Action

- 2 Scroll (⏪) to **Security ID** and press **SELECT** (⏹).
- 3 Enter a 3-digit number and press **DONE** (⏹).
- 4 Press **EXIT** (⏹) twice to return to the standby screen, or press (⏪) to scroll to a different feature.

Recording a Memo

Press (MEMO) on the base station to record a message that you can playback later.

Using the Answer Machine

Checking Messages from the Base Station

Action

- | | |
|-------------|---------------------------|
| Press (▶) | to play and stop messages |
| Press (▶▶) | to skip forward |
| Press (◀◀) | to skip backward |
| Press (del) | to delete message |

Checking Messages from an Expansion Handset

Action

1 Press **MENU** (≡), scroll (⬇️) to **Messages**, and press **SELECT** (≡).

2 Scroll (⬇️) to the function you want, then press **SELECT** (≡). The selections are:

2:Play/Stop

3:Skip

4:Answer On/Off

5:Memo

7:Repeat menu

0:Erase



Checking Messages Remotely from a Touch-Tone Phone

Action

- 1 Call your base station.
- 2 When the answering machine picks up the call, enter the security ID. A synthesized voice prompts you with instructions.
- 3 To skip the voice prompts and operate the base station directly, press the appropriate number key on the phone. The selections are:

Press 2 abc	to play/stop messages
Press 3 def	to skip forwards
Press 1	to skip backwards
Press 4 ghi	to answer (turns the answering machine on/off)
Press 5 jkl	to record a memo
Press 7 pqrs	to repeat the memo
Press 0 oper	to delete the message

For your convenience, cut this page out and take it with you so you'll have it when you call your answering machine while you are away from home. Use the other side of this page to write down notes and phone numbers.

Advanced Features

To use some of the advance features, you need at least 2 (up to 4) expansion handsets registered to the base station.

You can expand your phone system by adding cordless handsets (up to a total of 4 expansion handsets). Expansion handsets do not require connection to a phone line. You can place the handset and its charging base anywhere a standard electrical outlet is available.

With multiple expansion handsets, you can:

- Conference call
- Talk handset to handset on the intercom
- Set up handsets to automatically answer intercom calls
- Transfer calls from one handset to another
- Monitor a room
- Use 2 handsets as walkie talkies

To order expansion handsets, call:

1-800-353-2729 USA

1-888-390-6456 TTY (Text Telephone)

On the Web:

www.motorola.com/cordless

Conference Calling

If one handset is already on a call, the display on other handsets registered to the same base station shows **Line in use**.

Once a second handset is added to the call, the display on all handsets shows **On conference**. A maximum of 2 handsets can be on a conference call at the same time.

Action

To connect a second handset to a call, press **ON** or **Handsfree** on the second handset.

To join a conference call, press **ON** from the base station.

To disconnect from the conference call, press **OFF** on either or both handsets.

Using the Intercom

Intercom Setup

You can set up a handset or base station so it automatically answers an intercom page after 1 or 3 rings. All handsets are set to No Auto Answer at the factory. Perform the following procedure on each handset to change this setting.

Action

- 1 Press **MENU** (☐).
- 2 Scroll to **Intercom Setup** and press **SELECT** (☐).
- 3 Scroll to one of the answering options and press **SELECT** (☐):
No Auto Answer—The handset does not automatically answer an intercom page.
After 1 Ring or **After 3 Rings**—The handset automatically answers and turns on the speakerphone after 1 or 3 rings.
- 4 Press **SELECT** (☐).
- 5 Press **EXIT** (☐) to return to the standby screen, or (⌂) to scroll to a different menu option.

Handset to Handset Intercom

Action

- 1 Press **Intercom**.
- 2 From the list of handsets, press (⌂) until ▶ points to the handset you want to page, or to **Select All** to page all handsets.
Note: If you have only 1 expansion handset, pressing the Intercom button automatically pages the base station and vice-versa.

Action

- 3 Press **PAGE** (☎).
- 4 To answer the page, press **OK** (☎). The first handset to respond is connected.
If no one answers the page after 2 minutes, or if the person you are paging presses **EXIT** (☎) or **OFF, No Answer** displays on your handset and paging stops.
- 5 When someone answers the page, talk into the handset.
- 6 To end the intercom session, press **OFF**.

To turn the speakerphone on or off, press **Handsfree**.

To mute or unmute the sound, press **MUTE** (☎) or **UNMUTE** (☎).

Transferring a Call from One Handset to Another

Unannounced Transfer

Action

- 1 Press **HOLD** (☎).
- 2 Press **Intercom**.

Action

- 3 Scroll to the handset you want to transfer the call to and press **PAGE** (≡).

Note: If you have only 1 handset, pressing the Intercom button automatically pages the other handset, and vice-versa.

- 4 Press **OFF** to hang up. The call is transferred to the other handset.

Announced Transfer

Action

- 1 Follow steps 1 through 3 above.
- 2 To answer the page on the other handset, press **OK** (≡).
- 3 Tell the person on the other handset that you are transferring a call, then press **UNHOLD** (≡). The call is transferred to the other handset and all three individuals are on the call.
- 4 Press **OFF** (≡) to hang up the 2nd handset.

Using the Handset as a Walkie Talkie

The walkie talkie feature lets you talk handset to handset even when the handsets are out of range from the base station. When a handset is in walkie talkie mode, you cannot make or receive phone calls. You must complete steps 1 and 2 for both handsets to use walkie-talkie mode.

Action

- 1 Press **MENU** (☐).
- 2 Scroll to **Walkie Talkie** and press **SELECT** (☐).
- 3 Press **Intercom** on one of the handsets.
- 4 Press the number on the handset keypad that corresponds to the handset you want to use walkie talkie with.

For example, if the handset you want to talk to is named **Kitchen(2)**, press 2 on the keypad.
- 5 To answer the page on the other handset, press **OK** (☐).
- 6 To end the walkie talkie session, press **EXIT** (☐) on either handset.

Monitoring a Room

Room monitoring allows you to place a handset in a room and listen to the sounds in that room from another handset.

Action

- 1 Place a handset in the room to be monitored.
- 2 On that handset, press **MENU** (≡).
- 3 Scroll to **Monitor Room** and press **SELECT** (≡). The display shows **Ready to monitor room**.
- 4 On the handset you want to listen from, press **Intercom**. The display lists the handsets registered to the base station.
Note: If you have only 1 handset, pressing the **Intercom** button automatically pages the other handset.
- 5 Scroll to the handset you set up monitoring on and press **PAGE** (≡).

The handset that was set up for monitoring automatically answers the page. The microphone on that handset is turned on, and the speaker is turned off. The handset you are monitoring from shows **Monitoring (handset name)**.

You can also use the base station for monitoring by following the instructions above from the base station.

To turn off monitoring, press **CANCEL** (≡) or **OFF** on either handset.

Note: If you answer an incoming call, monitoring is turned off.

Deregistering All Expansion Handsets



You may deregister all expansion handsets from the base station.

Caution: Read and perform the following instructions carefully. Missing a step or performing a step incorrectly may render your telephone system inoperable.

Action

- 1 Delete or listen to all voice mail messages, if necessary, to clear the **IN USE/voice mail** indicator.

Note: Skip this step if it does not apply to your MD Series cordless telephone model.

- 2 Press **OFF** on the base station and all handsets.
- 3 Press and hold down **PAGE** on the base station until the **IN USE** indicator begins to flash slowly, then release **PAGE**.
- 4 Press and hold down **PAGE** again until the **IN USE** indicator begins to flash quickly, then release **PAGE**.
- 5 Quickly and fully press and release **PAGE** again.
- 6 Register handset displays. Press **OK** () to begin the registration process (see page 20), or press **EXIT** ().

Motorola Limited Warranty for the United States and Canada

What Does this Warranty Cover?

Subject to the exclusions contained below, Motorola, Inc. warrants its telephones, pagers, messaging devices, and consumer two-way radios that operate via Family Radio Service or General Mobile Radio Service ("Products"), Motorola-branded or certified accessories sold for use with these Products ("Accessories") and Motorola software contained on CD-ROMS or other tangible media and sold for use with these Products ("Software") to be free from defects in materials and workmanship under normal consumer usage for the period(s) outlined below. This limited warranty is a consumer's exclusive remedy, and applies as follows to new Motorola Products, Accessories and Software purchased by consumers in the United States or Canada, which are accompanied by this written warranty

Products and Accessories

Products Covered	Length of Coverage
Products and Accessories as defined above, unless otherwise provided for below.	One (1) year from the date of purchase by the first consumer purchaser of the product unless otherwise provided for below.
Decorative Accessories and Cases. Decorative covers, bezels, PhoneWrap™ covers and cases.	Limited lifetime warranty for the lifetime of ownership by the first consumer purchaser of the product.
Monaural Headsets. Ear buds and boom headsets that transmit mono sound through a wired connection.	Limited lifetime warranty for the lifetime of ownership by the first consumer purchaser of the product.

Products Covered	Length of Coverage
Consumer Two-Way Radio Accessories	Ninety (90) days from the date of purchase by the first consumer purchaser of the product.
Products and Accessories that are Repaired or Replaced	The balance of the original warranty or for ninety (90) days from the date returned to the consumer, whichever is longer.

EXCLUSIONS

Normal Wear and Tear. Periodic maintenance, repair and replacement of parts due to normal wear and tear are excluded from coverage.

Batteries. Only batteries whose fully charged capacity falls below 80% of their rated capacity and batteries that leak are covered by this limited warranty.

Abuse & Misuse. Defects or damage that result from: (a) improper operation, storage, misuse or abuse, accident or neglect, such as physical damage (cracks, scratches, etc.) to the surface of the product resulting from misuse; (b) contact with liquid, water, rain, extreme humidity or heavy perspiration, sand, dirt or the like, extreme heat, or food; (c) use of the Products or Accessories for commercial purposes or subjecting the Product or Accessory to abnormal usage or conditions; or (d) other acts which are not the fault of Motorola, are excluded from coverage.

Use of Non-Motorola Products and Accessories. Defects or damage that result from the use of Non-Motorola branded or certified Products, Accessories, Software or other peripheral equipment are excluded from coverage.

Unauthorized Service or Modification. Defects or damages resulting from service, testing, adjustment, installation, maintenance, alteration, or modification in any way by someone other than Motorola, or its authorized service centers, are excluded from coverage.

Altered Products. Products or Accessories with (a) serial numbers or date tags that have been removed, altered or obliterated; (b) broken seals or that show evidence of tampering; (c) mismatched board serial numbers; or (d) nonconforming or non-Motorola housings, or parts, are excluded from coverage.

Communication Services. Defects, damages, or the failure of Products, Accessories or Software due to any communication service or signal you may subscribe to or use with the Products, Accessories or Software is excluded from coverage.

Software

Products Covered	Length of Coverage
Software. Applies only to physical defects in the media that embodies the copy of the software (e.g. CD-ROM, or floppy disk).	Ninety (90) days from the date of purchase

Exclusions

Software Embodied in Physical Media. No warranty is made that the software will meet your requirements or will work in combination with any hardware or software applications provided by third parties, that the operation of the software products will be uninterrupted or error free, or that all defects in the software products will be corrected.

Software NOT Embodied in Physical Media. Software that is not embodied in physical media (e.g. software that is downloaded from the internet), is provided “as is” and without warranty.

Who is Covered?

This warranty extends only to the first consumer purchaser, and is not transferable.

What will Motorola Do?

Motorola, at its option, will at no charge repair, replace or refund the purchase price of any Products, Accessories or Software that does not conform to this warranty. We may use functionally equivalent reconditioned/refurbished/pre-owned or new Products, Accessories or parts. No data, software or applications added to your Product, Accessory or Software, including but not limited to personal contacts, games and ringer tones, will be reinstalled.

To avoid losing such data, software and applications please create a back up prior to requesting service.

How to Obtain Warranty Service or Other Information

USA	Phones 1-800-331-6456 Pagers 1-800-548-9954 Two-Way Radios and Messaging Devices 1-800-353-2729
Canada	All Products 1-800-461-4575
TTY	1-888-390-6456
For Accessories and Software , please call the telephone number designated above for the product with which they are used.	

You will receive instructions on how to ship the Products, Accessories or Software, at your expense, to a Motorola Authorized Repair Center. To obtain service, you must include: (a) a copy of your receipt, bill of sale or other comparable proof of purchase; (b) a written description of the problem; (c) the name of your service provider, if applicable; (d) the name and location of the installation facility (if applicable) and, most importantly; (e) your address and telephone number.

What Other Limitations Are There?

ANY IMPLIED WARRANTIES, INCLUDING WITHOUT LIMITATION THE IMPLIED WARRANTIES OF MERCHANTABILITY AND FITNESS FOR A PARTICULAR PURPOSE, SHALL BE LIMITED TO THE DURATION OF THIS LIMITED WARRANTY, OTHERWISE THE REPAIR, REPLACEMENT, OR REFUND AS PROVIDED UNDER THIS EXPRESS LIMITED WARRANTY IS THE EXCLUSIVE REMEDY OF THE CONSUMER, AND IS PROVIDED IN LIEU OF ALL OTHER WARRANTIES, EXPRESS OR IMPLIED. IN NO EVENT SHALL MOTOROLA BE LIABLE, WHETHER IN CONTRACT OR TORT (INCLUDING NEGLIGENCE) FOR DAMAGES IN EXCESS OF THE PURCHASE PRICE OF THE PRODUCT, ACCESSORY OR SOFTWARE, OR FOR ANY INDIRECT, INCIDENTAL, SPECIAL OR CONSEQUENTIAL DAMAGES OF ANY KIND, OR LOSS OF REVENUE OR PROFITS, LOSS OF BUSINESS, LOSS OF INFORMATION OR DATA, SOFTWARE OR APPLICATIONS OR OTHER FINANCIAL LOSS ARISING OUT OF OR IN CONNECTION WITH THE ABILITY OR INABILITY TO USE THE PRODUCTS, ACCESSORIES OR SOFTWARE TO THE FULL EXTENT THESE DAMAGES MAY BE DISCLAIMED BY LAW.

Some states and jurisdictions do not allow the limitation or exclusion of incidental or consequential damages, or limitation on the length of an implied warranty, so the above limitations or exclusions may not apply to you. This warranty gives you specific legal rights, and you may also have other rights that vary from state to state or from one jurisdiction to another.

Laws in the United States and other countries preserve for Motorola certain exclusive rights for copyrighted Motorola software such as the exclusive rights to reproduce and distribute copies of the Motorola software. Motorola software may only be copied into, used in, and redistributed with, the Products associated with such Motorola software. No other use, including without limitation disassembly of such Motorola software or exercise of the exclusive rights reserved for Motorola, is permitted.

motorola.com

6864110W32-A