

Mechanic's Guide

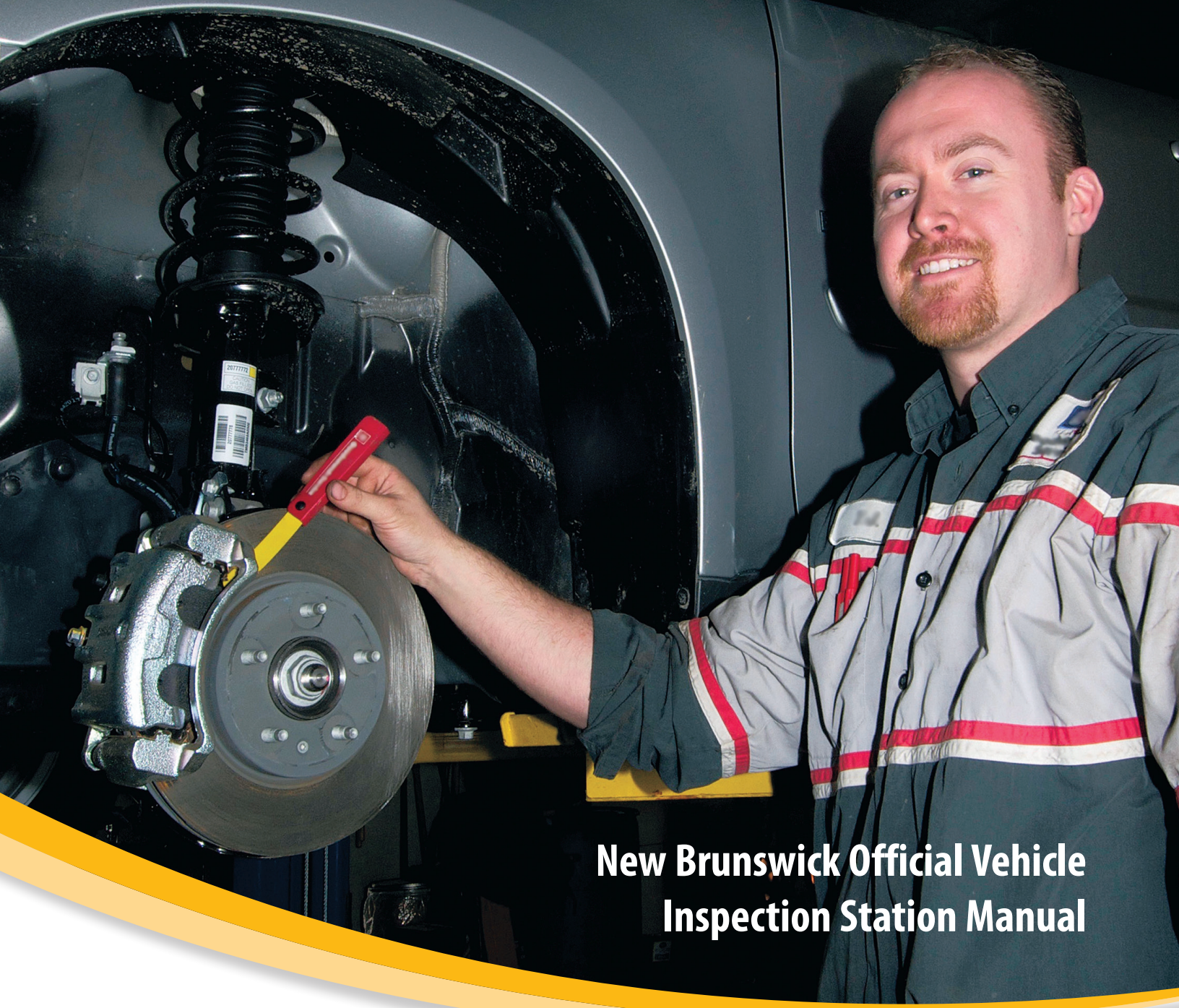

**New Brunswick Official Vehicle
Inspection Station Manual**

**New Brunswick Official Vehicle Inspection Station Manual:
*Mechanic's Guide***

Published under the authority of the
Province of New Brunswick,
Department of Justice and Public Safety
P.O. Box 6000
Fredericton, NB E3B 5H1

ISBN 1-55396-054-8

Revised June 2021
12750

Table of Contents

SECTION 1	5
Introduction	5
Station Licence Application	7
Requirements for Licensing of an Official Vehicle Inspection Station	8
Types of Inspection Licences Issued	9
Equipment	10
Official Vehicle Inspection Station Sign	10
Fee Chart	10
Duties and Responsibilities of an Inspection Station Licensee	11
Role of the Department of Justice and Public Safety Motor Vehicle Inspector	12
Vehicle Inspection Staff Qualifications	13
Mechanic Certificates	14
Certified Mechanic Responsibilities	15
Vehicle Registration	15
Approval Sticker Location	16
Rejection Sticker Location	16
Approval Sticker and Report Form Ordering	16
Sale of Vehicle for Junk, Parts or Salvage	17
Approval Stickers and Report Books	17
Rejection Stickers	17
Re-Inspection	18
Replacement Stickers	18
Inspection Routine	19
Vehicle Inspection Report	19
SECTION 2	20
SECTION 3	52

SECTION 1

Introduction

Upon applying to offer the services of a New Brunswick Official Vehicle Inspection Station, the licensee accepts the responsibility to properly inspect all vehicles submitted for inspection. Any licensee who fails to fully maintain the standards outlined in the **Official Vehicle Inspection Station Manual** is subject to the loss of the privilege of conducting official motor vehicle inspections.

The procedures as outlined herein should be carefully reviewed by your certified mechanics, as well as any other staff members involved in the motor vehicle inspection program. There can be no meaningful highway safety without safe vehicles. Members of the motoring public count on the careful work of licenced mechanics, who conduct the inspections, to reduce the likelihood of accident or injury, due to mechanical failure of their motor vehicle.

The information found in this manual is based on the direction found in the *Motor Vehicle Act* and in the Regulations to the Act, which can be found online at www.gnb.ca/acts.

Information in this manual will be used when inspecting:

- Passenger vehicles;
- Family motor coaches;
- Antique automobiles;
- Taxis;
- Commercial vehicles (with unladen curb mass of 3499 kilograms or less);
- Recreational trailers; and
- Utility trailers (but does not apply to vehicles with air brakes)

Careful use of the information in this manual will ensure that all inspections are performed in the manner prescribed by law. Included are:

- Procedures;
- Requirements;
- Performance Standards, for inspection of those items identified for examination under the *Compulsory Vehicle Inspection Program*, in New Brunswick; as well as
- Reasons for which various items might be considered unsafe.

Please note

- All items listed **must** be inspected.
- Each procedure outlined for the inspection must be completed **as directed**.
- Careful attention must be paid to the **reasons** for rejection.
- An approval sticker **must not be issued** for a vehicle which fails to meet the minimum safety requirements, as identified by this program.
- Every person who makes a false statement in completing a Vehicle Inspection Report may be found guilty of an offence and be subject to penalties prescribed by the *Motor Vehicle Act*.
- Also, a **Motor Vehicle Repair Certificate of Qualification** as issued under Occupation Regulation – *Apprenticeship and Occupational Certification Act* may be subject to suspension or cancellation.

Station Licence Application

An application to be licenced as a New Brunswick Official Vehicle Inspection Station may be obtained from the:

Motor Vehicle Branch
Department of Justice and Public Safety
P.O. Box 6000
Fredericton, NB E3B 5H1
Telephone: 506-453-2410
Fax: 506-462-2130
Email: mvi_idv@gnb.ca

Applications are also available at any **Service New Brunswick** office in the province.

Each application submitted to a licensing office of the Motor Vehicle Branch of the Department of Justice and Public Safety must be accompanied by payment of the required licence fee. In the event of rejection of an application, the fee will not be returned. A statement of responsibilities is enclosed with the application forms.

Prior to approval for a licence, each applicant's premises will be visited by a Motor Vehicle Inspector to determine suitability for appointment as a New Brunswick Official Vehicle Inspection Station. A report of the Inspector's findings will be provided to a Licensing Officer of the Motor Vehicle Branch. The Licensing Officer will then evaluate the completed application information and the Inspector's report. If found to be acceptable, the Applicant will be advised of approval as a New Brunswick Official Motor Vehicle Inspection Station Licensee, by the Licensing Officer.

All cheques or money orders must be made payable to the **Minister of Finance**.

Requirements for Licensing of an Official Vehicle Inspection Station

According to the classification of inspection licence issued, each station must employ at least one licensed mechanic, who possesses a *Certificate of Qualification* in one of the following trades:

- Motor Vehicle Mechanic (Automobile);
- Motor Vehicle Repair (Steering, Suspension and Brakes);
- Motor Vehicle Repair (Truck & Transport) or Truck Trailer repairer as issued under Occupation Regulation – *Apprenticeship and Occupational Certification Act*.

Each station must have sufficient inside working space to accommodate:

- the vehicle during its inspection;
- the certified mechanic; and all
- tools and equipment necessary to perform the inspection.

Minimum inside space requirements:

- a) not less than 3.5 metres (11.6') in width
- b) 7.5 metres (25') in length (*if mechanical headlamp aimers or headlamp testing equipment is used*)
- c) 15 metres (50') in length (*if headlamp aim testing screen is used*)
- d) 5 metres (16.6') additional length is required for heavy vehicle inspection stations.

Business sign and opening hour requirements:

Each inspection station (except fleet only) is required to display a minimum of one professionally built business sign and opening hours.

Note

Both signs must be displayed outside, facing the public view.

Types of Inspection Licences Issued

1. Regular Inspection

Issued to stations conducting inspections on:

- All buses (*except school buses or contracted conveyances*)
- Motor vehicles with an unladen curb mass of 3499 kilograms or less;
- Utility trailers; and
- Recreational trailers (*excluding any vehicle with air brakes*)

2. School Bus Inspection

Issued to stations conducting inspections on:

- School buses; and
- Contracted conveyances.

3. Heavy Vehicle Inspection

Issued to stations conducting inspections on:

- Buses (*except school buses or contracted conveyances*);
- Motor vehicles 3500 kilograms unladen curb mass or more.;
- Semi-trailers;
- Trailers; and
- Pole trailers.

4. Fleet Inspection

Issued to stations inspecting:

- A fleet of **ten or more vehicles** - Restricted to vehicles registered or operated by the licensee. (*except school buses or contracted conveyances*).

Licence privileges may be combined. For example a licence may be issued to allow for regular inspections and also for heavy inspections.

Note

Special Recreational Trailer Inspection privileges may be extended to retail recreational trailer outlets. Please inquire to the Licensing Officer at the Motor Vehicle Branch of Department of Justice and Public Safety, Fredericton, NB.

Equipment

The following list of equipment is not intended as a complete list but rather as a guide describing tools and parts which should be available to an inspection mechanic:

- Common hand tools;
- Headlamp aiming device (*One of 3 types. Headlamp aiming devices using adapters must be in a complete assembly, as per designed by manufacturers.*) Including blue adapters;
- Hoisting device: Hoist or Pit (*Suitable for the vehicles being inspected*);
- Jack, jack stands;
- Welder, cutting torch;
- Compressor;
- Torque wrench;
- Trouble light;
- Tire pressure gauge;
- Tire tread depth gauge;
- Brake drum and brake rotor gauge Vernier Caliper;
- Sealed beam replacement units;
- Brake fluid;
- Assorted lamps;
- Fuses; and
- Windshield wiper blades.

Official Vehicle Inspection Station Sign

The sign provided, designating the facility as an **Official Inspection Station** must be:

- Displayed unaltered in a prominent place to inform the motoring public of the Licensee's official authority;
- Maintained in good condition by the Licensee.

Fee Chart

The fee chart:

- Designates fees applicable to all vehicles which are required to be inspected by the compulsory vehicle inspection program in New Brunswick;
- Must be posted where it can be viewed by the public at all times.

Note

Any headlamp aiming device using adapters must be in a complete assembly, as per designed by the manufacturer.

Duties and Responsibilities of an Inspection Station Licensee

Each Official Vehicle Inspection Station licensee must fulfil the following responsibilities:

1. Each vehicle inspection must be made by, or under the direct supervision of, a mechanic who possesses the required *Certificate of Qualification* as issued under Occupational Regulation – *Apprenticeship and Occupational Certification Act*.
2. The provision of inspection services to the public must conform with all the standards outlined in this Manual.
3. Inspection approval limits established must be applied to each vehicle inspected.
4. The tools and equipment available at the Inspection Station must be adequate for inspection and repair of the vehicle being inspected. The headlamp aim inspection equipment must meet the approval of the Department of Justice and Public Safety Motor Vehicle Inspector.
5. Careful completion of inspection reports, proper distribution of report copies and control over stickers must be assured at all times.
6. The lending or borrowing of inspection supplies between Inspection Stations is **strictly** prohibited.
7. Fees charged the public for vehicle inspections shall be **only** at the rate prescribed by the *Motor Vehicle Act* Regulations.
8. The Inspection Station Licensee must notify the the Motor Vehicle Branch immediately of:
 - a) Complaints
 - b) Loss or theft of stickers or report forms
 - c) Request to adopt procedural changes
 - d) Report errors in vehicle registration to the Motor Vehicle Branch, Department of Justice and Public Safety.
 - e) Desire to cease operations as an Inspection Station and have all inspection supplies returned
 - Stickers
 - Report books
 - Manuals
9. Credit for inspection stickers will be considered only when an inspection station has permanently ceased operation.
10. The following items must be displayed in full public view at all times:
 - Official Motor Vehicle Inspection Station Licences;
 - Procedure charts; and
 - Official Motor Vehicle Inspection Station Signs.
11. All inspection material must be at the licensed premises during regular business hours and must be available for inspection by a Peace Officer , Motor Vehicle Inspector or any Official of the Motor Vehicle Branch.
12. Renewal of the Official Vehicle Inspection Station Licence must be made prior to December

31st of each year, together with full payment of the licence fee.

13. The Inspection Station Licence is valid for the issued location only. If a Licensee wishes to perform vehicle inspections at more than one location, a separate licence is required for **each** location.
14. The Inspection Station Licensee is responsible for all inspection duties under their licence, including inspection work performed by any of their employees.
15. The Inspection Station Licensee is responsible for maintaining an adequate stock of inspection supplies, to provide continuous service to the public.
NOTE: Motor vehicle inspections cannot be conducted if the station is out of inspection supplies at the time of inspection.
16. All motor vehicle inspection must be conducted on the **premises**.

Role of the Department of Justice and Public Safety Motor Vehicle Inspector

Motor Vehicle Inspectors, employed by the Department of Justice and Public Safety, are both peace officers and journeyman mechanics. The Inspectors will make direct contact with the Inspection Station licensee, normally on-site at the inspection station.

Initially, Motor Vehicle Inspectors will conduct an on-site visit to inspect the premises of each Inspection Station. This inspection is done to ensure that all requirements are met with regard to space, equipment and staff. Motor Vehicle Inspectors will then normally visit every Inspection Station on one or more occasions each year when time permits.

The Motor Vehicle Inspectors are also prepared to review and investigate complaints lodged by both Inspection Stations and by members of the public. They are available to provide assistance to both groups at any time with regard to:

- Regulations;
- Procedures; and
- General inquiries.

Moncton Region	Fredericton Region	Saint John Region	Bathurst Region	Edmundston Region
856-2958	444-4814	658-3005	547-2940	423-3088

Inquiries regarding:

- Vehicle Inspection;
- Garage And Dealer Licences;
- Inspection Stickers; and
- Vehicle Inspectors should be directed to the Manager,

Motor Vehicle Branch
Department of Justice and Public Safety
P. O. Box 6000
Fredericton, NB E3B 5H1
Telephone: 506-453-2410
Fax: 506-462-2130
Email: mvi_idv@gnb.ca

Vehicle Inspection Staff Qualifications

The motor vehicle mechanics who operate under this program are required to be holders of certificates of qualification in the:

- Motor Vehicle Mechanic (Automobile);
- Motor Vehicle Mechanic (Truck and Transport);
- Motor Vehicle Mechanic (Steering Suspension and Brakes); or
- Truck and Trailer Mechanic occupation as issued under Occupation Regulation – *Apprenticeship and Occupational Certification Act*.

Each Official Vehicle Inspection Station is required to have at least one **appropriately** licensed mechanic on duty while a vehicle is being inspected under the Compulsory Vehicle Inspection Program.

Mechanic Certificates

The following outlines the required mechanic's Certificates of Qualification for the various types of vehicles inspected.

1. All motor vehicles and buses 3499 kilograms or less unladen curb mass, recreational trailers and utility trailers may be inspected by certified mechanics who are holders of any of the following certificates of qualifications:
 - a) Motor Vehicle Mechanic/Automotive Service Technician (Automobile)
 - b) Motor Vehicle Mechanic/Automotive Service Technician (Steering Suspension & Brakes)
 - c) Motor Vehicle Mechanic/Truck & Transport Service Technician (Truck & Transport)The above mechanics can inspect any trailer no matter its size **except** those **trailers** which have an **air brake system**. Any trailer with air brakes can **only be inspected** by mechanics who hold licences in the following categories:
 - a) Truck and Transport Service Technician (Truck & Transport)
 - b) Commercial Trailer Technician (Truck Trailer Repairer)
2. All motor vehicles, buses, and semi-trailers, trailers or pole trailers may be inspected by certified mechanics who hold a Certificate of Qualification in Motor Vehicle Mechanic (Truck & Transport).
3. All semi-trailers, trailers, pole trailers, recreational trailers and utility trailers requiring inspection may be inspected by certified mechanics who are holders of the Certificate of Qualification, Truck Trailer Repairer Trade.
4. Special inspection provisions may apply to retail recreational trailer dealers, who are primarily engaged in the sale and repair of recreational trailers. Please contact a Licensing Officer at the Motor Vehicle Branch of Department of Justice and Public Safety, Fredericton (506-453-2410).
5. All motorized vehicles with air brakes must be inspected by a Truck and Transport Mechanic.

Note

A Motor Vehicle Mechanic (Truck and Transport) can perform safety inspections on any vehicle, with no weight restrictions.

Certified Mechanic Responsibilities

The inspection station mechanic must:

1. Become thoroughly familiar with the vehicle inspection requirements as outlined in the Official Motor Vehicle Inspection Manual and be able to satisfy the **Motor Vehicle Inspector** with the level of knowledge held.
2. Directly supervise or perform each vehicle inspection according to the outlined procedure and, therefore, assure vehicle owners that their inspection was properly carried out.
3. Exercise care in completing the Vehicle Inspection Report form legibly (in ink), and in recording the correct sticker number placed on the vehicle by the licensed mechanic.
4. Remove the inspection sticker on a vehicle prior to beginning the inspection.
5. **Never** pre-sign Vehicle Inspection Reports.

Vehicle Registration

During the inspection of vehicle components, the certified mechanic is required to obtain the vehicle registration from the vehicle owner. The registration plate and serial number shown should match the plate and serial number attached to the vehicle.

Where the plate and serial number are not identical, the certified mechanic must:

- a) Examine the vehicle plate and serial number and compare this with the plate and serial number shown on the vehicle registration;
- b) Record the correct vehicle plate and serial number on the Vehicle Inspection Report Form. Contact the **Motor Vehicle Inspector** in your area to advise of the discrepancy.

Moncton Region	Fredericton Region	Saint John Region	Bathurst Region	Edmundston Region
856-2958	444-4814	658-3005	547-2940	423-3088

Note

The fact that the plate(s) or serial number on the vehicle does not match the plate(s) or serial number on the registration is not sufficient reason to cause the vehicle to be rejected. By notifying the Motor Vehicle Branch, Department of Justice and Public Safety, of the error the necessary corrections can be made. (506-453-2410)

Vehicles requiring inspection, where no registration certificate is available, may be inspected in the normal manner remembering to indicate on the Vehicle Inspection Report Form that the registration has not been verified.

Note

Former school buses converted to other uses, i.e. church buses, family motor coach, shall be refused inspection if the following conditions have not been completed:

- 1. Colour must be changed from that displayed by provincial school buses.*
- 2. Amber and red flashing warning lights must be removed.*

Approval Sticker Location

All stickers prefixed **HV, AV** or **SV** (*with adhesive on the face side*) shall be placed on the inside lower left corner of the windshield on all motor vehicles required to be inspected.

All stickers prefixed **AT** (*with adhesive on the back*) shall be placed on the left side, front corner, at a readable height on all trailers, pole trailers or semi-trailers required to be inspected.

Rejection Sticker Location

- On the **outside** lower left corner of the windshield on all motor vehicles **failing** to pass inspection.
- On the **left side front corner**, covering any existing sticker, at a readable height, on all semi-trailers, pole trailers or trailers **failing** to pass inspection.

Approval Sticker and Report Form Ordering

It is the responsibility of each Inspection Station Licensee to maintain an adequate stock of inspection supplies to provide continuous inspection services to the public.

The control and safeguarding of inspection supplies is the responsibility of the Inspection Station Licensee. Only an Inspection Station Licensee or their designated agent may complete and order these supplies, since safeguarding and accounting is the Licensee's responsibility. Upon receipt of supplies the Licensee is required to verify quantities. If there is a discrepancy the licensee must immediately notify the Licensing Officer.

The ordering of inspection stickers should be carefully monitored during the last months of the year to prevent over-stocking. Please return all **unused stickers** that are not being used. The amount will be credited towards your next sticker purchase.

Sale of Vehicle for Junk, Parts or Salvage

When a vehicle is to be disposed of for any of these noted reasons, any current year **Approval Certificate** must be removed and destroyed.

Approval Stickers and Report Books

- The Approval Sticker must be punched to designate the month and year in which the Approval Sticker will expire.
- When punching Approval Stickers, use caution to ensure correct validation.
- Incorrectly punched stickers must be replaced at the expense of the Licensee.
- Approval Stickers and Report Books must be used in the order of the numbers indicated on them.
- Strict control over sticker issue must be maintained, by the Licensee, **at all times**.

Rejection Stickers

- Rejection sticker information must be completed by the certified mechanic, on the front side of the sticker, showing the date of inspection.
- A rejection sticker will be issued when a vehicle fails to meet the minimum safety requirements outlined by this manual.
- Operation of an unsafe vehicle is an offence, under the *Motor Vehicle Act*, Section 206(1):
No person shall operate and no owner shall cause or knowingly permit to be operated any vehicle or combination of vehicles that
(a) is in such unsafe condition as to endanger any person...
- Two consecutive rejection stickers **cannot** be issued for a vehicle, (in any one year or two year inspection cycle) unless approved by the Registrar of Motor Vehicles.
- Rejection stickers are to be removed by a certified mechanic and replaced with an approved sticker, after all of the previously failed items have been repaired, re-inspected and approved.

Re-Inspection

The space denoted on the *Vehicle Inspection Report* Forms as **Previous Inspection Report No.** must be used in four instances:

1. When re-inspection of a vehicle is necessary due to failure on first attempt. Only those items which have previously failed and have been repaired should be checked if the same Inspection Station is involved. In such a case, the previous Inspection Report number is noted, the re-inspection performed and no inspection fee is warranted during the 14-day extension period.
2. When a vehicle is presented for re-inspection at **other than the original inspection station**, it shall be re-inspected and charged the full inspection fee.
3. When a vehicle is presented for re-inspection, **at the same inspection station**, following the elapse of the 14-day extension period, it shall be totally re-inspected and charged the full inspection fee.
4. When replacement of an approval sticker is issued due to windshield replacement (see below for details on this matter).

Note

In no instance of re-inspection must a rejected vehicle sticker be removed until after the re-inspection items have been approved. Rejection stickers can only be issued once to any one vehicle, allowing only one 14-day period in any inspection cycle, unless an extension is approved by the Registrar of Motor Vehicles.

Replacement Stickers

When replacement of an Approval Sticker is necessary (e.g. windshield replacement) this can be achieved at the original Inspection Station, or at any station which is licensed to inspect this category of vehicle, by the certified mechanic completing the following:

1. Record the previous report number on the new report form.
2. Check off the box marked replacement.
3. Issue and record on the new report form, replacement sticker number.
4. Punch out the replacement sticker with an expiry date identical to that of the original sticker.
5. The fee for Approval Sticker replacement is as prescribed in Section 7(4) of *Regulation 83-185*.

Inspection Routine

1. All inspections must be performed on the premises which the Motor Vehicle Branch has licensed as an **Official Inspection Station**.
2. **The first step** is always to remove any existing sticker, except in the case of **AT** (annual trailer sticker) which may be attached to an easily marred surface of a trailer. In this case a new sticker must be placed over the sticker being replaced.
3. There is no precise required sequence for completing vehicle inspections excepting item 2 here above. Each certified mechanic is free to develop a procedure which fulfils all legislative requirements and appears to be the most suitable for that station or vehicle.

Vehicle Inspection Report

After a vehicle has been fully inspected an inspection report form must be completed reflecting the nature of the findings for that particular vehicle.

1. Each report must be printed so it can be easily read;
2. All required report items must be completed;
3. The first report part (**yellow** copy) must be issued to the vehicle owner;
4. The second report part (**white** copy) must be forwarded to the Manager of Licensing at the Licensing & Registration Branch, either on a monthly basis, or with each order of inspection supplies, whichever occurs first;
5. The third report part (**pink** copy) must be retained at the inspection station for the validation of the certificate of inspection.
 - One years certificate , pink inspection report must be kept for a minimum of two years
 - Two years certificate , Pink inspection report must be kept for a minimum of two years.
 - Three years certificate , pink inspection report must be kept for a minimum of three years; and
6. In the case of school bus or contracted conveyance, report parts 1, 2, and 3 are sent to the locations indicated on the forms, while the fourth part is retained at the Inspection Station, for a period of not less than one year from date of issue.

SECTION 2

Requirements and Performance Standards

Glass

• INSTRUCTIONS

Critical Vision Area

For the purpose of this Vehicle Inspection Program, the critical vision area of windshield is defined to include all of that area swept by the windshield wiper blades properly adjusted and using factory installed wiper arms and blades or equivalent replacements.

REJECT VEHICLE IF:

1. Any treatment coating or application of coloured spray or material or any opaque or reflective material has been applied to the windshield, side wings, side windows to right or left of the driver.
2. The windshield contains any cracks, fractures or other defects in the critical vision area.
3. The windshield, side wings, side or rear windows are broken in any area exposing sharp or jagged edges.
4. The windshield is discoloured in the critical vision area.

NOTE

Windshields having small stone nicks ,chips or repair not over 13 mm (1/2 in.) long are not to be considered grounds for rejection. All other glass requirements apply. All replacement glass in any vehicle or motor vehicle shall be of the safety type.

Horn(s)

- **INSTRUCTIONS**

Every motor vehicle when operated upon a highway shall be equipped with a horn audible at a distance of not less than 60 metres (200 ft.).

REJECT VEHICLE IF:

1. The horn is not securely fastened to the vehicle.
2. The horn button or actuating device does not function properly.
3. The output of a horn is insufficient to produce an adequate warning under normal conditions at a distance of 60 metres (200 ft.).
4. Push buttons not to replace original steering wheel horn button.

NOTE

If a vehicle is factory equipped with more than one horn, all must operate properly.

Windshield Wiper(s)

• **INSTRUCTIONS**

Every motor vehicle shall be equipped with a windshield cleaning device.

REJECT VEHICLE IF:

1. The vehicle is not equipped with factory installed windshield wiper blades, wiper arms or equivalent replacements.
2. The windshield wiper blades show signs of physical breakdown of the rubber wiping element.
3. The arms fail to return to original position or the blade fails to contact the windshield firmly.
4. The windshield washer fails to operate as designed.
5. Rear wiper is not functional.

NOTE

Rear wiper can be removed but hole must be plugged.

Rearview Mirror

• INSTRUCTIONS

Every motor vehicle shall be equipped with a mirror adjusted to allow the driver a reflected unobstructed view for a distance of at least 60 metres (200 ft.) to the rear of the vehicle.

REJECT VEHICLE IF:

1. The vehicle is not equipped with a rearview mirror.
2. The mirror is not mounted securely enough to prevent movement.
3. The mirror is cracked, pitted or clouded to the extent that rear vision is obscured.
4. The mirror is very difficult to adjust or will not maintain a set adjustment.
5. The mirror does not provide a reflected unobstructed view of highway at least 60 metres (200 ft.) to the rear of the vehicle.
6. Any original equipment manufacture or equivalent mirror is missing from it's original installation.

NOTE

Additionally installed mirrors must conform with the inspection standards applied to factory installed mirrors.

Exhaust System

• INSTRUCTIONS

The exhaust system may include the exhaust manifolds, pipes, muffler, catalytic converter, tail pipes, brackets, gaskets and clamps.

REJECT VEHICLE IF:

1. The entire exhaust system is not complete and elements of the system are not securely fastened.
2. There is an exhaust system cut-out or similar device.
3. Any part of the exhaust system passes through occupant compartment.
4. Any element of the exhaust system is deformed to an extent which prevents the normal escape of exhaust gases.
5. Any element of the exhaust system is rusted or deteriorated to the extent of allowing exhaust gases to escape at other than the normal discharge point.
6. The muffler is insecure, missing, leaking, improperly patched, (muffler tape) loose or missing baffles.
7. Any emission control system is removed, disabled, or altered from its original manufacture installation.

NOTE

Tail pipe must exit according to manufacturer's specifications.

Holes in the exhaust system made by the manufacturer for drainage are not cause for rejection.

Body and Associated Components

• INSTRUCTIONS

1. General body condition
2. a & b Fuel tank assembly and lines
3. Sun visor
4. – a & b Seat and adjusting mechanism
5. - 7 . Seat belts.
8. Bumpers

REJECT VEHICLE IF:

1. Torn metal, or other loose or dislocated parts protrude from the surface of the vehicle causing a safety hazard.
Note: Rust holes are not permitted whatsoever.
2. a) Fuel tank and lines are leaking.
b) Fuel tank mounting supports and fasteners are loose, broken, cracked or missing.
3. Driver visor is missing or will not maintain a set adjustment.
4. a) Broken seats frame, loose or missing fastener.
b) Adjusting mechanism does not operate as intended.
5. a) Any original seat belt assembly, or parts thereof, have been removed.
b) Seat belt anchorage is insecure.
6. Seat belt buckle or retractor does not function as intended.
7. Seat belt webbing is visibly frayed, cut, torn or otherwise damaged.
8. The bumper (front or back) is missing, badly displaced, rusted through, loosely attached, broken or torn portion is protruding creating a hazard.

NOTE

- *Fuel tank assembly, lines and fittings must be properly connected and routed as per original manufacture installation.*
- *Police vehicles shall not fail because of missing interior rear door handles or window opening devices.*
- *Any "replacement bumper" must be equivalent to original equipment manufacture . "measurements " must remain within the vehicle manufacture specification.*

Body and Associated Components

• INSTRUCTIONS

9. – 12. Fenders, hood, doors, floor pan and inner panels.

13. On vehicles having unitized bodies, inspect all structural members and in particular those members that support critical components such as suspension, steering or power train.

16. Front windshield defroster operation.

17. a, b Battery holder stabilizer tray and battery hold-down device.

REJECT VEHICLE IF:

9. Fender, hood or engine cover is missing , hood secondary or safety catch does not function properly.

10. Hood latch release mechanism or its parts are broken, missing or incorrectly adjusted so that the hood cannot be opened and closed in a normal manner.

11. Any door hinge, handle or latching device is missing or fails to function properly.

12. If doors, windows, trunk lids are not operational and properly sealed or the floor pan and inner panels, in either the occupant compartment or trunk, have openings sufficient to permit the entry of exhaust gas.

13. The frame, unitized body members , cross members and body mounts are missing, loose , fractured, misaligned, cracked, rusted in a manner that may affect the structure of the vehicle.

14. Speedometer is not in working order and does not show the speed at which the vehicle is travelling.

15. Odometer is not in working order.

16. The air fan fails to work in one single switch control position.

17. a) Any Battery holder stabilizer tray is missing, loose, or broken.

b) Any battery hold down device is missing, loose, or broken.

NOTE

- *Any repair and assembly of the body components must be carried out in such a way as to provide occupant protection that is equal to/or exceeds original equipment manufacture standard.*
- *Where the body or components thereof form the primary structure or frame of the vehicle, repairs by rivets or screws is not acceptable; must be mig welded.*

Lights

• INSTRUCTIONS

General lamp inspection includes all those lamps and/or reflex reflectors which are factory installed or required by law.

REJECT VEHICLE IF:

1. Any filament in any lamp required by the Motor Vehicle Act or Regulation fails to function as required.
2. Any lamp fails to light the proper filament indicated at switch position.
3. Any lamp, lens or reflex reflector is broken, missing, incorrectly installed, discoloured, indicating a colour contrary to law or is improperly secured to the vehicle.
4. Any auxiliary equipment is placed in, on or in front of any lamp.
5. Directional signal self-cancelling mechanism is not functioning correctly.
6. Back-up light system does not turn off automatically when vehicle is in a forward motion.
7. Any headlamp fails to have the letters "DOT" horizontally or vertically on the lens.
8. Any headlamp that has the word "motorcycle" on the lens.
9. Daytime running lamps fail to illuminate with engine running.
10. High mounted brake lamp fails to light.
11. If any lamps or lights have been covered with tinted lenses or other devices.

NOTE

- *Some vehicles require transmission to be in forward gear in order for running lamp to illuminate*
- *Suggest service brake be applied before putting vehicle in gear.*

Lights

Headlamp Aiming – On-board Device

On vehicles equipped with a Vehicle Headlamp Aiming Device (VHAD), aiming and aim checks may be performed on the vehicle if the vehicle is placed on a level surface. The level surface may be four level pads that the vehicle tires rest on. Preparation of the vehicle is similar to other aiming methods as far as loading and physical condition of vehicle.

• INSTRUCTIONS

With the vehicle properly located and loaded, check horizontal indicator and position of vertical aim bubble relative to the scale. Correct aim is “0” for horizontal and “0” for vertical.

REJECT VEHICLE IF:

- The horizontal indicator shows:
 - More than 0.8 degrees **left** or
 - More than 0.8 degrees **right**
- Or if vertical aim bubble shows:
 - More than 0.8 degrees **up** or
 - More than 0.8 degrees **down**

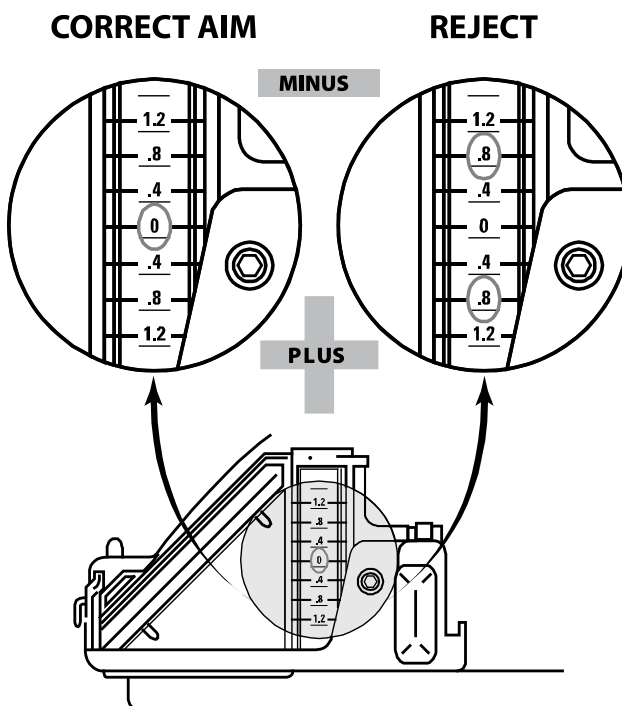

Lights

Headlamp Aiming – Other methods

Headlamp beams should be inspected for alignment by one of the following methods:

1. With mechanical headlamp aimers.
2. On a screen at a distance of approximately 7.62 metres (25 ft.) forward of the headlamps.
3. With an optical aimer using a photo-electric cell or cells or mirrors to achieve equivalent result to a screen method.

NOTE

If either a mechanical or optical aimer is used, it shall be in good repair and adjusted according to the manufacturer's instructions.

Lights

Headlamp Aiming by Screen Method

First place the vehicle so that it is square with the screen and with the front of the headlamps directly over a reference line which has been painted on the floor.

Next, locate the centre line on the aiming screen so that it is in line with the centre of the rear window of the vehicle and over the hood ornament (have vehicle moved until it is in alignment with these two points). If there is no centre hood ornament, mark the centre of the front and rear window with narrow strips of masking tape. Use these "sights" to locate the centre line of the aiming screen directly in line with the vehicle axis.

Aiming Area Required

A specific aiming area in a darkened location is sufficient for the vehicle and an additional 7.62 metres (25 ft.) measured from face of lamps to the front of the visual screen. The floor on which the vehicle rests must be flat and level with the bottom of the screen. If the floor is not level, compensate.

Aiming Screen

If a screen is used, it should be 1.9 metres (5 ft.) high and 3.6 metres (12 ft.) wide with a matte white surface well shaded from extraneous light and properly adjusted to the floor on which the vehicle stands. Provisions may be made for moving the screen so that it can be aligned parallel with the rear axle and so that a horizontal line drawn perpendicularly from the centre line of the screen will pass an equal distance midway between the two headlamps.

The screen shall be provided with a fixed vertical center line, two laterally adjustable vertical tapes and one vertically adjustable horizontal tape.

If a regular commercial aiming screen is not available, the screen may consist of a vertical wall having a clear uninterrupted area approximately 1.9 metres (5 ft.) high and 3.6 metres (12 ft.) wide.

The surface should be finished with a washable non-gloss white paint. After the aiming screen has been set up in its permanent location, it is necessary to paint a reference line on the floor directly under the lens of the lamps to indicate the proper location of the headlamps when they are being aimed.

Fog Lamps

If a vehicle is equipped with fog lamps, they should be aimed properly. The moveable horizontal and vertical lines on the aiming screen should be located so that they cross at the straight-ahead positions of the center line of each fog lamp, whether they are symmetrical or nonsymmetrical.

Lights

Headlamp Aiming – Mechanical

Equipment

Approved set of mechanical aimers. Calibrate mechanical aimer to “0”. Consult aimer instruction manual for procedure.

• INSTRUCTIONS

Vehicle must be positioned on a level area.

Always adjust lights to a setting of 0 – 0 when using a mechanical aimer.

Attach mechanical aimer in accordance with aimer manual instructions. Take readings.

REJECT VEHICLE IF:

1. Horizontal aim is more than:
 - 100 mm (4 in.) to the **left** or **right**.
2. Vertical aim is:
 - higher than 100 mm (4 in.) **up** or lower than 100 mm (4 in.) **down**.

Brakes

• INSTRUCTIONS

Brake Components – Hydraulic Systems

Make a visual inspection of all components for signs of leakage, deterioration, restrictions.

Fluid Level

Inspect fluid level in the hydraulic brake system reservoir.

Pedal Travel

REJECT VEHICLE IF:

Brake Components – Hydraulic Systems

1. The hoses and tubing leak.
2. Wheel cylinder or brake caliper leaks, seized or insecurely mounted as per original manufacture installation or equivalent.
3. Any flexible brake hoses or tubing show signs of rust deterioration, kinks, compressed areas, ballooning or deterioration of rubber covered fabric hoses or not properly secured.

Fluid Level

1. The fluid level is more than 13 mm (1/2 in.) below the lowest edge of the filler opening, in either reservoir chamber or is below the minimum level indicated by manufacturer.

Pedal Travel

1. The brake pedal when fully depressed does not maintain a position for one full minute where one third (1/3) of pedal travel remains.

NOTE

- *Any brake hoses and tubing repairs or installation must meet original equipment manufacture standard or equivalent.*
- *The use of copper tubing in a hydraulic brake system as a substitute for steel brake lines is NOT permitted.*
- *The use of "approved" copper and nickel brake lines is permitted*
- *Flexible brake hoses shall not be installed with more than a 15 degree twist.*
- *The use of any compression unit is not permitted.*

Brakes

• INSTRUCTIONS

Brake Components

Reserve capacity of a vehicle's braking system must be analyzed by a visual check of the brake linings or brake pads.

NOTE:

THIS CHECK MUST BE MADE BY REMOVING ALL WHEELS OR DRUM ASSEMBLY AS REQUIRED FROM EACH AXLE.

Anti-lock braking system (ABS) shall operate in accordance with manufacturers' specifications.

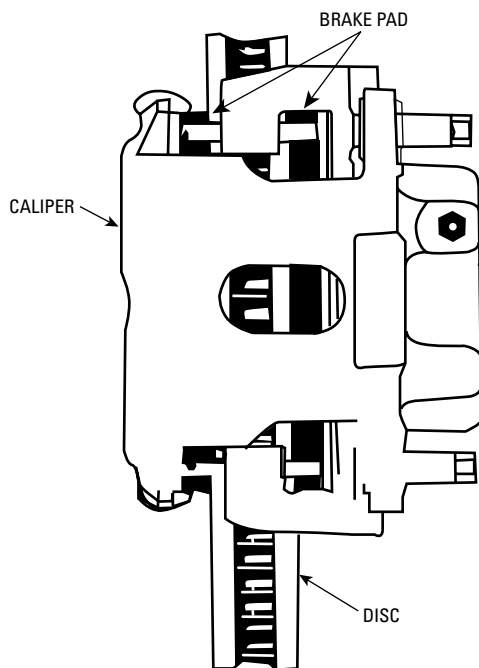

TYPICAL DISC BRAKE

REJECT VEHICLE IF:

Brake Components

1. Any bonded lining is less than 1.6 mm (2/32 in.) when measured at the thinnest point.
2. Any riveted lining surface is closer to the rivet head than specified by the vehicle manufacturer or if not specified 1.6 mm (2/32 in.) at the thinnest point.
3. Any disc brake wear indicator is indicating that the friction material is worn beyond the manufacturer's recommended limit or contacting the rotor.
4. The anti lock braking system shows any indication of not being operational.
5. Any brake lining is broken or loose on its shoe or pad.
6. Any brake lining shows evidence of contamination sufficient to affect braking performance.
7. If brake pads or brake shoes do not have **FULL CONTACT** with brake drum or brake rotor during application; i.e. corrosion build-up.
8. Any brake hardware component is loose, broken, inoperable, seized, missing or not installed as per manufacture installation.

Brakes

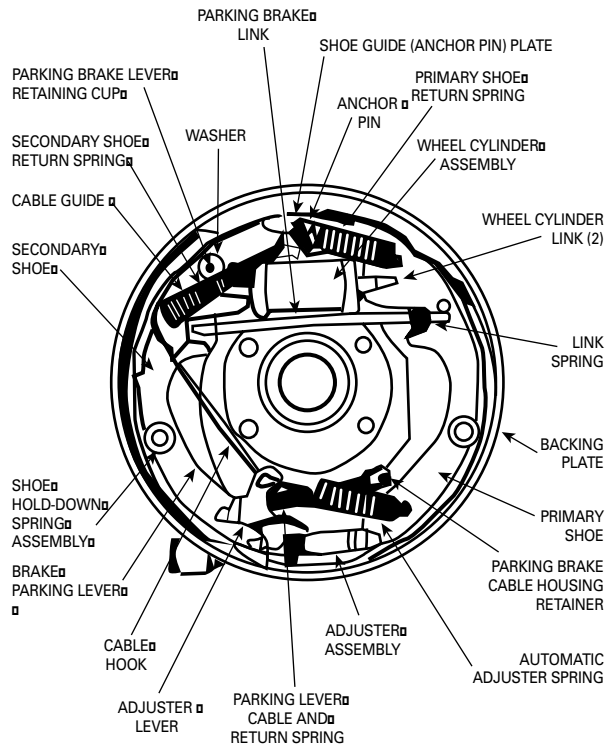

TYPICAL SERVO DRUM BRAKE

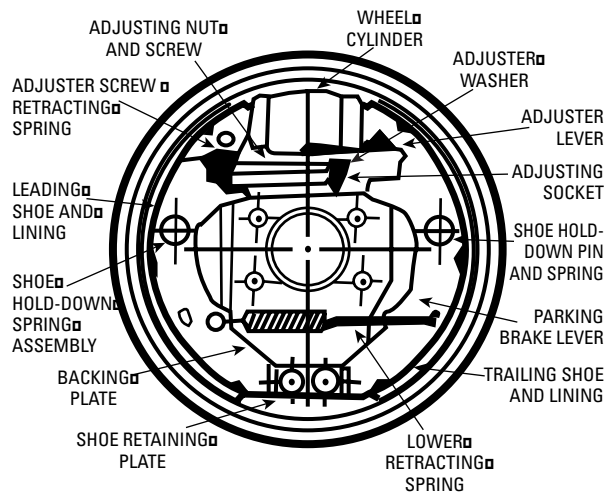

TYPICAL NON-SERVO DRUM BRAKE

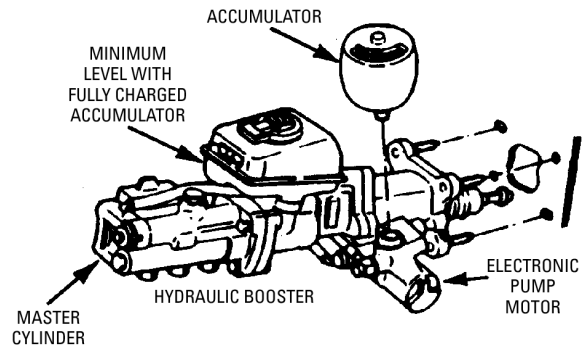

TYPICAL INTEGRATED HYDRAULIC BOOSTER ANTI-LOCK SYSTEM

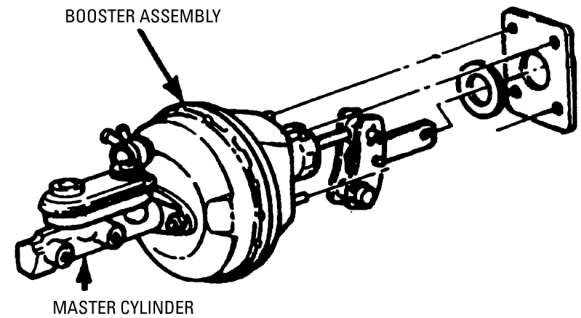

TYPICAL VACUUM BOOSTER ASSEMBLY

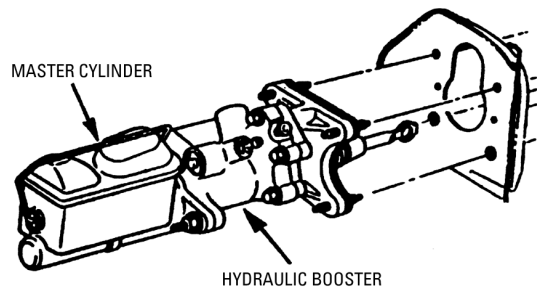

TYPICAL HYDRAULIC BOOSTER ASSEMBLY

Brakes

• INSTRUCTIONS

Brake Drum

1. Check friction surface for cracks extending to open edge of drum.
2. Inspect for mechanical damage and contaminated friction surface.

Brake Rotor

1. Inspect rotor for mechanical damage.

Vacuum Booster and Hydraulic Booster

1. With engine stopped depress brake pedal several times. Then depress brake pedal with a light foot force, maintain this force and start engine.

Vacuum Segment of System

1. Run the engine to build full vacuum and then with the engine and ignition shut off, make one full brake application.

REJECT VEHICLE IF:

Brake Drum

1. The drum has cracks on friction surface extending to the open edges.
2. Mounting holes elongated or the friction surface is contaminated.
3. Any brake drum has an inside diameter greater than the maximum diameter stamped on the drum.

Brake Rotor

1. The rotor has cracks on the friction surface extending to an open edge.
2. Any brake disc has a thickness less than the minimum thickness stamped on the disc.

Vacuum Booster and Hydraulic Booster

1. The pedal does not move slightly as engine is started while force is on brake pedal.

Vacuum Segment of System

1. There is insufficient vacuum reserve to permit one full brake application after engine is shut off.

Brakes

Parking Brake Operations

• INSTRUCTIONS

1. Inspect parking brake function for setting and release as per manufacture design. Set the parking brake firmly.

REJECT VEHICLE IF:

1. The parking brake will not hold the vehicle stationary with the engine running at slightly accelerated speed with shift lever in drive position or with shift lever in low gear with clutch engaged for standard transmission.
2. Set and release functions of parking brake do not operate properly.
3. Any parts of the parking brake system that does not meet original manufacture equipment installation or equivalent.
4. Brake system warning light fails to illuminate or remains on after park brake is released.

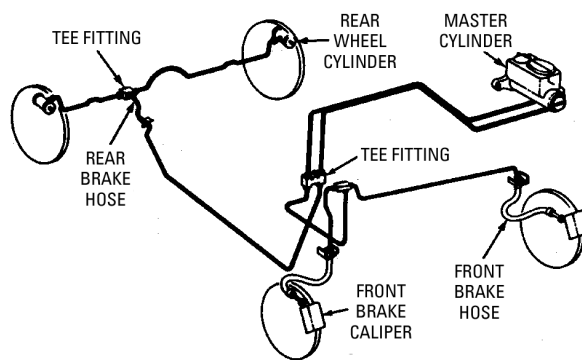

TYPICAL FRONT / REAR BRAKE SYSTEM

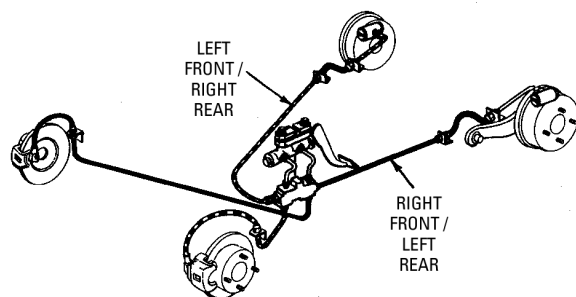

TYPICAL DIAGONAL BRAKE SYSTEM

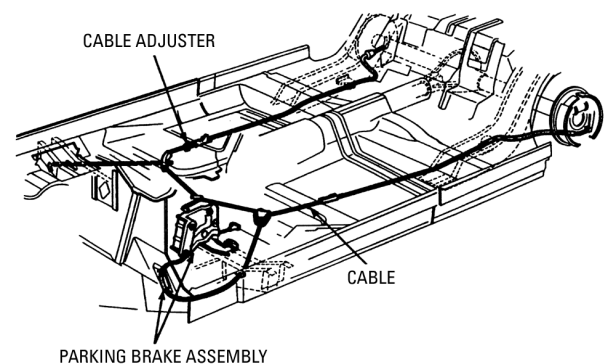

PARKING BRAKE ASSEMBLY

Steering and Suspension

• INSTRUCTIONS

Steering System Travel

1. Turn steering wheel through a full right and left turn (on vehicles without power steering, it may be desirable to unload front wheels slightly by raising off the surface).

Steering system

2. a,b,c Manually and visually inspect for major fluid leaks and operation.

NOTE:

this visual inspection must be performed when engine is running at low idle speed (RPM) and the fluid level, belt tension condition must be within manufacture specification before testing.

Steering and Suspension Systems

Shock absorbers and shock struts

1. With vehicle on level surface push down on one corner at a time and release.

NOTE

A dampness or minor seepage from an oil filled shock absorber is not cause for rejection.

REJECT VEHICLE IF:

Steering System Travel

1. The front wheels are incapable of being turned to the right and left steering stops without binding or interference.

Steering system

2. a) System does not operate as intended.
b) Cracked, deterioration, ballooning, kinks or defective covered fabric hoses.
c) constant active leak is apparent.

NOTE:

A dampness or minor seepage of the power steering is not a cause for rejection

Steering and Suspension Systems

1. The rear axle is not in proper alignment with the longitudinal axis of the vehicle as determined by the visual inspection.
2. Any shock absorber, stabilizer or steering linkage is defective, disconnected, broken, bent or worn beyond manufacturer's specifications.
3. The steering or suspension systems have been modified so as to affect the proper alignment or steering of the vehicle.
4. Any suspension component is broken or fails to meet the minimum manufacturer's tolerances.
5. The frame or unitized body members are fractured, misaligned or rusted in any manner which would affect steering alignment or suspension.

Shock absorbers and shock struts

1. Vehicle continues free rocking motion after release, indicating loss of rebound retard.

Steering and Suspension

Information

Lifting techniques vary for measuring wheel bearing movement and steering linkage play. On vehicles with coil spring or torsion bar on lower support arm, hoist on frame. On vehicles with coil spring on upper support arm, hoist at lower support arm. On front wheel drive vehicles, the certified mechanic must consult the manufacturer's lifting information.

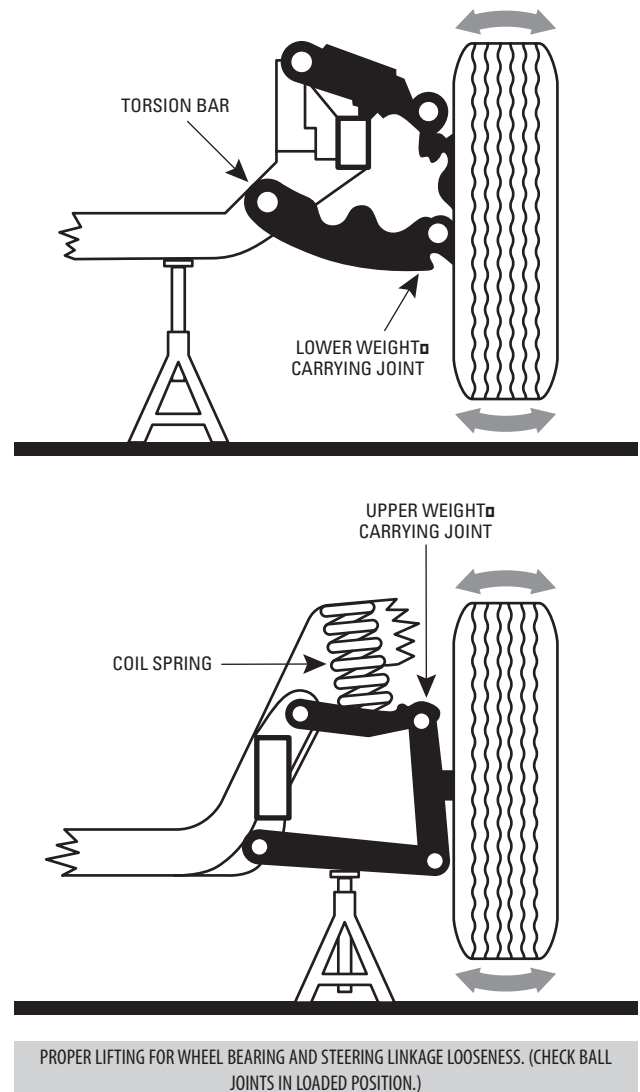

CAUTION

If air suspension vehicles are hoisted via body support area, air spring damage may occur if the air suspension switch is not turned off.

Steering and Suspension

• INSTRUCTIONS

Steering Linkage Play

1. For vehicles with power steering, engine must be running. Eliminate all wheel bearing movement by applying service brake. With vehicle lifted and wheels in straight ahead position, grasp front and rear of tire and attempt to move assembly without moving the steering gear.

REJECT VEHICLE IF:

Steering Linkage Play

1. Any component shows wear beyond manufactures specifications.

Lash or Free Play

Equipment

Ruler, scale or lash-checked instrument.

1. With wheels in straight ahead position, turn steering wheel until motion can be detected at the front road wheels. Align a reference mark on steering wheel with a mark on a ruler and slowly turn steering wheel in the opposite direction until motion can again be detected at front road wheel. Measure lash at steering wheel.

Lash or Free Play

1. The steering wheel movement exceeds:
Power: 51 mm (2 in.)
Manual: 76 mm (3 in.)
Rack and pinion (power or manual):
10 mm (0.4 in.)

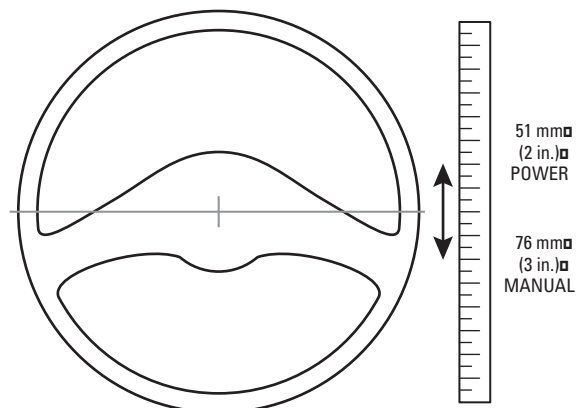

Steering and Suspension

• INSTRUCTIONS

Front Wheel Bearing on Rear Wheel Drive Vehicles or Rear Wheel Bearings on Front Wheel Drive Vehicles

1. With vehicle lifted properly, grasp tire at top and bottom, rock in and out and record movement. Wheel bearing looseness is detected by the relative movement between the brake drum or disc and the backing plate or splash shield.

King Pin Play

1. Eliminate all wheel bearing movement by applying service brake with the front end lifted. Grasp the tire at the top and bottom and attempt to move in and out to detect looseness. A pry bar may be necessary on heavy wheels. Measure the movement at the top or bottom of the tire at the outer circumference.

REJECT VEHICLE IF:

Wheel Bearings

1. Relative movement between drum and backing plate or disc and splash shield is more than 3 mm (1/8 in.) measured at the outer circumference of the tire or 6.4 mm (1/4 in.) for vehicles 2250 kg curb mass or greater.

King Pin Play

1. If measured movement at top or bottom of tire is greater than:
Wheel size
16 inches or less - 6.5 mm (1/4 in.)

Steering and Suspension

Ball Joint Wear

• INSTRUCTIONS

1. There is a trend among automobile manufacturers toward the use of “wear indicating” ball joints. Many motor vehicles, however, do not have wear indicating ball joints. The inspection of both types will be dealt with.

REJECT VEHICLE IF:

1. Ball joint movement is in excess of manufacturer’s service specifications.

NOTE

In checking for vertical motion of ball joints, keep in mind that the load carrying joint is unloaded when being tested, and that a pry bar pressure sufficient only to lift the weight of the wheel assembly is required. If the certified mechanic uses the “leverage” of a pry bar to exert excessive pressure, the mechanic can easily “force” an apparent ball joint movement and get a false reading. This may result in expensive replacement of perfectly good ball joints.

NOTE

The injection of materials into ball joints or suspension/steering components to fill voids caused by wear is not permitted.

Steering and Suspension

• INSTRUCTIONS

Ball Joints Without Wear Indicators

Equipment

Floor jack or hoist, safety stands and pry bar.

1. To check vertical movement, position a pry bar under the front tire and with a lifting motion sufficient to overcome the weight of the wheel assembly, move wheel up and down and observe movement.

To check horizontal movement, grasp the tire and wheel assembly at the top and bottom. Move in and out to detect looseness. More horizontal movement is allowable because of the nature of most ball joint construction. Some manufacturers do not accept horizontal movement as being indicative of ball joint wear.

Pre-Loaded Ball Joints

Equipment

Floor jack, safety stands and pry bar.

2. Using the same method as above, inspect for ball joint movement relative to its socket. These ball joints are pre-loaded by rubber or springs under load (or compression) and should have very little movement in a vertical direction, no more than specified in manufacturer's service specifications.

NOTE

In checking for vertical motion of ball joints, keep in mind that the load carrying joint is unloaded and that a pry bar pressure sufficient only to lift the weight of the wheel assembly is required. If the certified mechanic uses the "leverage" of a pry bar to exert excessive pressure, he can easily "force" an apparent ball joint movement and get a false reading. This may result in expensive replacement of perfectly good joints.

REJECT VEHICLE IF:

Ball Joints Without Wear Indicators

1. Ball joint movement is in excess of current manufacturer's service specifications.

Steering and Suspension

It is the responsibility of each inspection station licensee to "verify and ensure" that reference is made to current manufacturer's procedures when inspecting the steering and suspension.

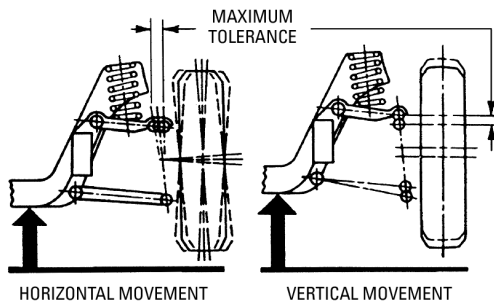

SPRING ON UPPER CONTROL ARM

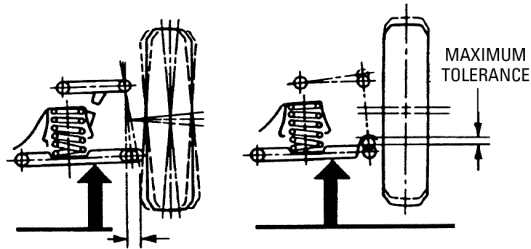

SPRING OR TORSION BAR ON LOWER CONTROL ARM

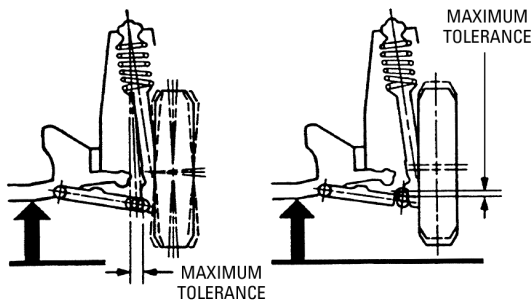

MACPHERSON STRUT

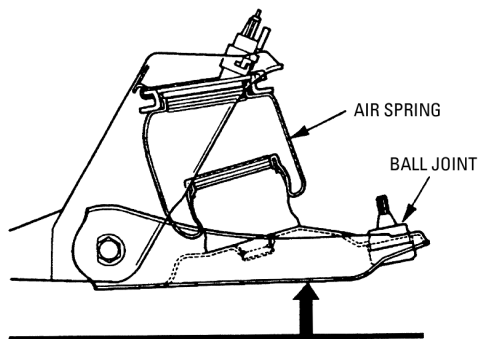

AIR SPRING

Steering and Suspension

Drive Train

- **INSTRUCTIONS**

1. Constant Velocity Joints
 - a. Rubber-Boot
 - b. Constant Velocity Joint

2. Any Drive shafts – front and rear where applicable
 - a. U- Joint
 - b. U-Clamps
 - c. Yoke, flange
 - d. Center bearing

REJECT VEHICLE IF:

1. Boot is torn or leaking
 2. Clamps missing or defective.
 3. Free play is evident or does not meet current manufacturer's specifications.
 4. Noisy or roughness in joint action.
-
1. U-Joint is seized or free play is evident.
 2. Loose U-clamps, nuts
 3. Loose , cracked or sign of welding on yokes or flange.
 4. Center bearing is defective does not meet current manufacturers' specification.

NOTE:

Drive train - Refer to manufacture specifications for proper testing.

Wheels and Tires

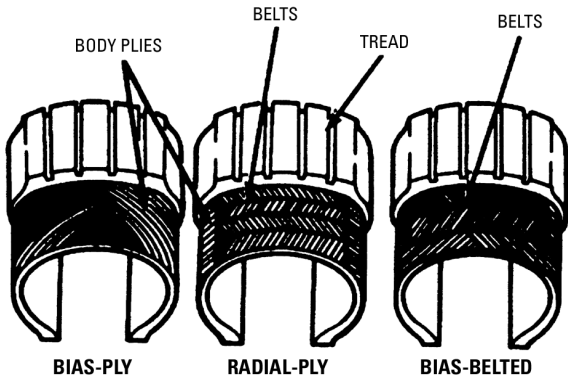

TIRE CONSTRUCTION DIAGRAM

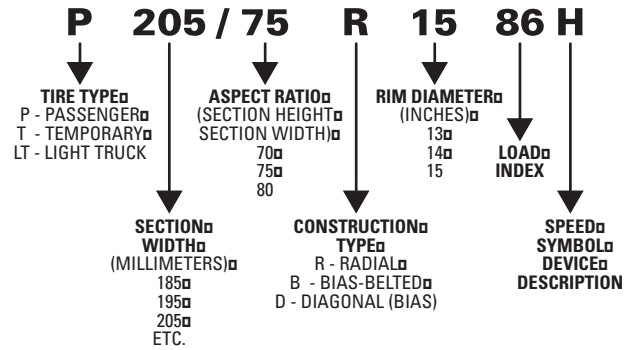
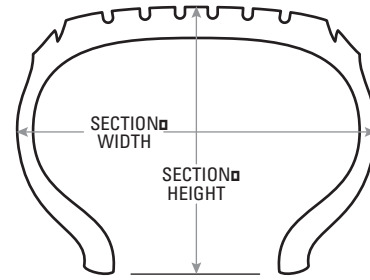

METRIC TIRE SIZE DIAGRAM

CONDITION	Rapid wear at shoulders		Rapid wear at center	Wear on one side		Bad spots or scalloped wear	Feathered edges
CAUSE	Underinflation at full load (high pressure on shoulder ribs)	Overinflation at bias tires at light load (low pressure on shoulder ribs)	Light loads on bias drive tires (driving torque concentrated on center ribs)	Excess toe or camber at full load (high pressure on outer side)	Excess toe or camber at light load (low pressure on inside rib)	Brake lock-up or excess toe in combination with loose steering joints or loose wheel bearings, or tire hop due to balance or runout	
CORRECTION	Adjust pressure to specifications when tires are cool Rotate tires			First inspect for incorrect toe and reset to minimum value in specification range, if toe setting is acceptable Adjust camber to specifications.		Correct loose steering and bearings. Correct balance and runout. Correct spotty brakes.	Adjust toe to specifications

TIRE WEAR PATTERNS

Wheels and Tires

Tire Tread Wear

• INSTRUCTIONS

1. Tires with tread wear indicator.
2. Tires without tread wear indicator.

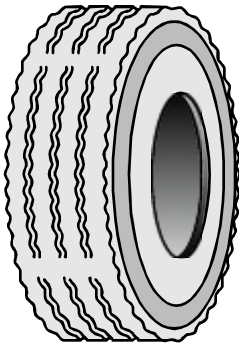

Any tire worn to the level of the tread wear indicators in any two or more adjacent tread grooves or when cord fabric is exposed.

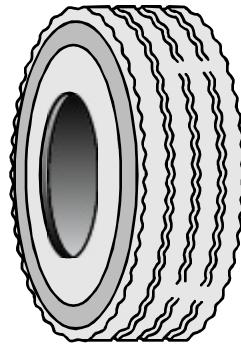

Any tire worn to the point where less than 1.6 mm (1/16 in.) of tread design depth remains in any two or more adjacent major tread grooves, exclusive of tie bars or when cord or fabric is exposed.

REJECT VEHICLE IF:

1. The tire is worn so that the tread wear indicators contact the road in any two adjacent grooves at three locations spaced approximately equally around the outside of the tire.
2. The tire is worn so that less than 1.6 mm (2/32 in.) tread remains when measured in any two adjacent major grooves at three locations spaced approximately equally around the outside of the tire.

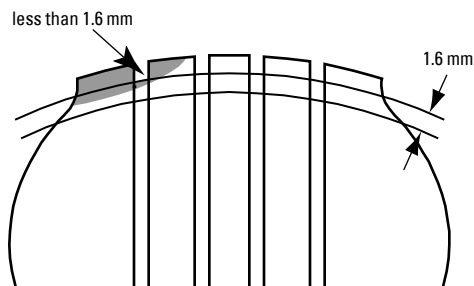

ACCEPTABLE

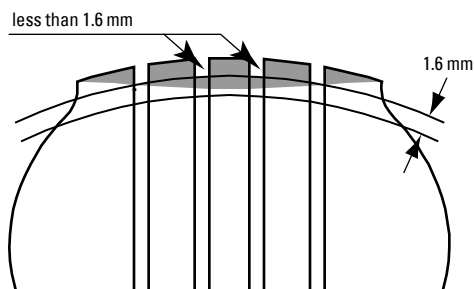

REJECT

TIRE TREAD DEPTH

Wheels and Tires

Wheels and Tires

- **INSTRUCTIONS**

General Requirements

REJECT VEHICLE IF:

1. Any tire has cord damage, ply separation causing any bump, bulge or has any visible blowout patches or is repaired by a plug in the sidewall.
2. Any tire is cut or weather cracked in excess of approximately 2.5 cm (1 in.) in any direction or to the extent of exposing tire cords.
3. Tire is marked "For Farm Use Only", "Off-Highway Use Only" or "For Racing Use Only", or not approved for highway use.
4. Any tire is of smaller size than the manufacturer's specified minimum size, or is sufficiently over size as to contact any vehicle component which may affect the safe operation of the vehicle.
5. A tire has been regrooved or recut below original groove depth, except special tires which have undertread rubber for this purpose and can be identified as such.
6. Any noticeable leak(s)

NOTE

The safest condition exists when all tires are either "conventional" or "radial" and not mixed.

Tire/Wheel size difference because of the existence of an original equipment temporary spare, or equivalent, should not be considered grounds for rejection.

Wheels and Tires

Wheels, Rims, Spokes

- **INSTRUCTIONS**

1. Check wheels, rims

REJECT VEHICLE IF:

1. Wheels, rims, nuts, studs are broken, missing, damaged, loose or incorrect type.

NOTE: ANY NUT MUST BE FULLY ENGAGED WITH THE STUD OR BOLT.

NOTE: NUTS AND BOLT MUST MEET (OEM) ORIGINAL EQUIPMENT MANUFACTURE STANDARD OR EQUIVALENT

Coupling Systems

Hitches

- **INSTRUCTIONS**

Except semi-trailers which are designed so that part of their mass and its load rest upon or is carried by another vehicle (i.e. fifth wheel trailers), there shall be two separate means of attachment so constructed and attached that the failure of one attachment will not permit the drawn vehicle to become detached.

REJECT VEHICLE IF:

1. The hitch or towing structure and attachments are insecurely mounted.
2. The latch mechanism fails to close securely on pintle or ball type hitch.
3. Any part is missing, cracked, seized or excessively worn.
4. Any cast or forge hitch shows indication that repairs have been made by brazing or welding.
5. Any connecting devices for the attachment of safety chains or cables are incapable of developing the full load capacity of the safety chains or cables.
6. The safety chains or cables do not have a load capacity at least equal to the rated hitch capacity.
7. Any safety chain that is too short or not of adequate size.
8. Any weld on chain except the original chain weld in each link.

NOTE

Safety chains must be "X" mounted to tow vehicle.

Coupling Systems

Fifth Wheel Coupling

- **INSTRUCTIONS**

Inspect the fifth wheel coupling device.

REJECT VEHICLE IF:

1. The fifth wheel is not fastened securely to the vehicle.
2. In the case of a fifth wheel secured to the vehicle frame by means of bolts, positive stops are not provided to prevent the fifth wheel from shifting on the frame.
3. The slider mechanisms, if fitted, do not lock securely or show signs of excess wear.
4. The jaw closure mechanism and locking system components are broken, cracked, out of adjustment or excessively worn.
5. Fifth wheel plate pins or bushing are excessively worn.

SECTION 3

Utility Trailer Inspection

Introduction

Utility Trailer Inspection Program

A “utility trailer” is a trailer, other than a recreational trailer, that has a gross mass of **1499 Kg or less**.

The following items are to be checked:

- a. tires and rims
- b. lights (tail, signal and brake)
- c. fenders, if applicable
- d. body condition
- e. suspension
- f. safety chains
- g. hitch
- h. wire harness
- i. coupling
- j. frame
- k. brakes and brake components if applicable. (Remove wheels)
- l. breakaway switch or similar device if required.

The other types of trailers which fall into the utility trailer category are:

- wood splitter
- portable flashing sign
- portable saw mill
- construction tool trailer
- construction office trailer
- mobile generator
- portable tar pot
- car dolly

NOTE

If a trailer type is not listed, please contact the inspector in your area.

Moncton Region	Fredericton Region	Saint John Region	Bathurst Region	Edmundston Region
856-2958	444-4814	658-3005	547-2940	423-3088

Requirements

Requirements for “newly” constructed utility trailers:

- Tail lights: Red (2)
- Brake lights: Red (2)
- Signal lights: Red or Amber (2)
- Plate light: White

Tail, brake and plate light are normally a combination of all three.

If trailer is 2 metres (80 in.es) or more in width, in addition to lights mentioned above the following is required:

- a. on front of trailer two (2) amber clearance lights, one on each side;
- b. on rear of trailer two (2) red clearance lights, one on each side;
- c. on each side near front one (1) amber reflector and near rear one (1) red reflector.

If trailer is not 2 metres (80 in.es) in width, the items (a), (b) and (c) are not required.

Other items which will be inspected are:

- fenders (if wheels are exposed)
- tires and wheels
- condition of body
- brakes (if applicable)
- safety chains
- trailer tongue, hitch & ball
- springs

Brakes

If the trailer and/or load weighs 3000 lbs. (1.5 tonnes) and is registered with a gross mass of **1500 Kg or more**, there must be brakes adequate to control and stop such vehicle and so designed as to be applied by the driver of the towing motor vehicle and connected in such a way that in case of an accidental breakaway of the trailer, the brake will automatically be applied.

The combination must be able to stop within ten (10) metres travelling at thirty (30) kilometres per hour.

There are utility trailers currently registered which will display one (1) red tail light and one (1) red brake light which will be permitted. However, newly constructed utility trailers will be required to meet federal standards which the Department of Public Safety, Licensing & Registration Branch has adopted.

Inspection Routine

In doing an inspection routine on a utility trailer, the vehicle normally used to tow the trailer is required to be available at the time of inspection so that the hitch and wiring harness can be checked on the tow vehicle.

Recreational trailer is a trailer which is used for recreational purposes and includes such vehicles as tent, travel, boat and snowmobile trailers. These trailers are required to be inspected annually.

Items to be checked:

- a. tires and rims
- b. lights (tail, signal & brake)
- c. fenders, if applicable
- d. body condition
- e. springs (if installed)
- f. safety chains
- g. hitch
- h. wire harness
- i. coupling
- j. frame
- k. brakes and brake components (Remove wheels)
- l. breakaway switch or similar device is required

Lights

• INSTRUCTIONS

General lamp inspection includes all lamps and reflectors which were factory installed and required by law. This includes taillights, left signal light, right signal light, brake lights, clearance lights and licence plate light.

REJECT VEHICLE IF:

1. Any filament required by the *Motor Vehicle Act* or Regulation fails to function as required.
2. Any lamp fails to light the proper filament indicated by switch position.
3. Any lamp, lens or reflex reflector is missing, incorrectly installed, discoloured, indicating a colour contrary to law or is improperly secured to trailer.
4. Any trailer wiring that is not secured, or does not have a connector which will allow easy connection and disconnection from tow vehicle.

NOTE

Any trailer 2 metres (80 in.) or more in width shall have: on the front, two (2) amber clearance lamps, one (1) on each side; on the rear, two (2) red clearance lamps, one (1) on each side; and on each side, an amber reflector at or near the front and a red reflector at or near the rear.

Brake

Hydraulic and electric brake systems.

• INSTRUCTIONS

Brake inspection must be analyzed by a visual check of the brake components and linings. This check must be made by removing "**all wheels or drum assembly**" as required from each axle.

NOTE:

- *Some trailers may require the towing vehicle to perform the brake inspection.*

NOTE:

- *Refer to manufacture for proper brake testing / operation.*

REJECT VEHICLE IF:

1. Any bonded lining is less than 1.6 mm (2/32 in.) when measured at the thinnest point or refer to manufactures specification.
2. Any riveted lining surface is closer to the rivet head than specified by the vehicle manufacturer or if not specified 1.6 mm (2/32 in.) at the thinnest point.
3. Any disc brake wear indicator is indicating that the friction material is worn beyond the manufacturer's recommended limit or contacting the rotor.
4. Any brake lining is broken or loose on its shoe or pad
5. Any brake lining shows evidence of contamination enough to affect braking performance.
6. The drum has cracks on the friction surface extending to the open edges.
7. The drum mounting holes elongated, or the friction surface is contaminated.
8. Any brake drum has an inside diameter greater than the maximum diameter stamped on the drum.
9. The rotor has cracks on the friction surface extending to an open edge.
10. Any brake disc has a thickness less than the minimum thickness stamped on the disk.
11. Any brake pads or brake shoe does not have full contact with brake drum or brake rotor during application, corrosion build-up.
12. The wheel cylinder or brake caliper leaks, seized or insecurely mounted as per original manufacture installation or equivalent.
13. The master cylinder is leaking, damaged, loose or fluid below manufacture specification.

Brake

REJECT VEHICLE IF:

14. Any brake hardware component is broken, inoperable, seized, missing, excessively worn or damaged that does not meet manufacture standard or equivalent.
15. Any electrical brake magnet actuator that is inoperable, seized, loose or damaged.
16. Any electrical wires are broken, shorted or not securely mounted.

17. Any brake hoses or tubing leak.
18. Any flexible brake hoses or tubing show signs of rust or deterioration, kinks, compressed area, ballooning or deterioration of the rubber covered fabric hoses.
19. The breakaway switch or similar device does not function as attended. Note: refer to manufacturer for proper testing.

NOTE:

- *The use of copper tubing in a hydraulic brake system as a substitute for steel brake lines is NOT permitted.*
- *Flexible brake hoses shall not be installed with more than a 15-degree twist.*
- *The use of any compression unit is not permitted.*
- *Any brake hoses and tubing repairs or installation must meet original equipment manufacture standard or equivalent.*

Suspension

• INSTRUCTIONS

Lift trailer so the wheels are off the floor so as access under the trailer can be made. Items to be checked are wheel bearings, axle springs and any other related components of suspension.

REJECT VEHICLE IF:

1. Any wheel bearing shows signs of failure or excessive end play of 3-mm (1/8 in.).
2. Any axle that is bent, cracked or corroded to an unsafe condition.
3. Any spring, shackle or related component that is bent, broken or fails to function.
4. Any axle assembly that has been modified for a trailer that has a design that is not suitable or structurally sound.
5. Any wheel and tire showing excessive toe in, toe out or excessive camber.

Wheels and Tires

• INSTRUCTIONS

1. Check tire tread wear and condition.
2. Check wheels, wheel bolt, nuts, studs.

REJECT VEHICLE IF:

1. The tire is worn so that the tread wear indicators contact the road in any two (2) adjacent grooves at three (3) locations around the tire.
2. The tire is worn so less than 1.6 mm (2/32 inch) tread remains at any two (2) locations around tire.
3. Any tire has cord damage.
4. Any tire has a cut or weather crack of approximately 25 mm (1 in.) in any direction.
5. Any tire marked for farm use only, off-highway or for racing use.
6. Any tire that has been regrooved.
7. Any wheel rims, bolts, studs, nuts or lugs are missing, damaged, bent or having elongated bolt hole or show signs of field welding.
8. Any noticeable leak(s).

NOTE

The use of a (DOT) automotive tire is acceptable.

NOTE

The tires should be conventional or radial - mismatched tires could cause unsafe handling condition.

NOTE

If trailer is 2 metres (80 in.) or more in width, mud flaps are required immediately behind rear tires.

Body

• INSTRUCTIONS

Check the general condition of the frame, bed, sideboards, fenders and pole.

REJECT VEHICLE IF:

1. Any torn metal, or loose, or dislocated part protrudes from the trailer that causes a safety hazard.
2. Any frame or body members are fractured, misaligned, cracked or rusted in such a manner that will affect the load carrying capabilities of the trailer.
3. The floor is deteriorated to not retain cargo.
4. Any side board or like component is deteriorated or not securely fastened.
5. Any trailer does not have fenders.
NOTE: Trailers that have tire assemblies under trailer bed do not require fenders.
6. The trailer pole is bent, cracked, distorted or made of wood.

NOTE

If trailer wheels are outside bed of trailer , then fenders are required . If wheels are under trailer bed , then mud flaps are required.

NOTE

Frame and pole cannot be wood.

Coupling Systems

• INSTRUCTIONS

1. Check the condition of coupling unit.
2. Check the condition of safety chains.
3. Light wiring connector.
4. Hitch of tow vehicle.

REJECT VEHICLE IF:

1. Any cracks or excessive wear of the coupler unit.
Any wear, cracks or failure of coupler latch to latch securely.
Any improper mounted coupler to pole.
2. Any safety chain is too short or is not of adequate size or has no fastening device to hitch.
NOTE: *Safety chains must be "X" mounted to tow vehicle.*
3. Any wiring connector cannot be easily connected and disconnected from tow vehicle.
4. Any hitch does not have the proper integrity to safely tow a trailer under the trailer operating condition (fully loaded trailer).
Any trailer where the hitch does not have (too light) the proper draw weight or tongue weight of the trailer it is towing.
Any trailer uses a pin or bolt type coupling.