



INSTITUTE OF AERONAUTICAL ENGINEERING
(Autonomous)
Dundigal, Hyderabad -500 043

MECHANICAL ENGINEERING
COURSE LECTURE NOTES

Course Name	APPLIED THERMODYNAMICS-I
Course Code	AMEB09
Programme	B.Tech
Semester	IV
Course Coordinator	Mr. G. Aravind Reddy, Assistant Professor
Course Faculty	Mr. G. Aravind Reddy, Assistant Professor
Lecture Numbers	1-129
Topic Covered	All

COURSE OBJECTIVES (COs):

The course should enable the students to:	
I	Understand the construction and working of internal combustion engines, compressors and refrigeration systems.
II	Develop the concept of ideal and real working of thermodynamic cycles for performance evaluation.
III	Understand the subsystems of internal combustion systems

COURSE LEARNING OUTCOMES (CLOs):

Students, who complete the course, will have demonstrated the ability to do the following:

CLO Code	At the end of the course, the student will have the ability to:
AMEB09.01	Understand main idea and importance behind the 2-S and 4-S IC engines
AMEB09.02	Analyze the working of the basic components in the IC engine
AMEB09.03	Understand the combustion process and also how it does affect the performance of the IC engines.
AMEB09.04	Apply the thermodynamic principles in the design of an IC engines
AMEB09.05	Formulate and perform the procedures required for the maintenance and operation of IC engine
AMEB09.06	Compare different IC engines and develop a system which meets the requirement
AMEB09.07	Knowledge of Fuel Requirements and Fuel Rating.
AMEB09.08	Testing and Performance of I.C Engines.
AMEB09.09	Analyze the working of the basic components in the Compressors and Refrigeration systems.
AMEB09.10	Apply the thermodynamic principles in the design of Compressors and refrigeration system
AMEB09.11	Formulate and perform the procedures required for the maintenance and operation of compressors and refrigeration systems.
AMEB09.12	Compare different compressors and refrigeration systems and develop a system which meets the requirements.

AMEB09.13	Understand the process of pressure enthalpy charts that are used in the Refrigeration systems.
AMEB09.14	Introduction to concepts of power and refrigeration cycles. Their efficiency and coefficients of performance.
AMEB09.15	Ability to use modern engineering tools, software and equipment to analyze energy transfer in required air-condition application.
AMEB09.16	Explore the use of modern engineering tools, software and equipment to prepare for competitive exams, higher studies etc.

SYLLABUS

MODULE I	IC ENGINES,FUEL INJECTION AND LUBRICATION SYSTEMS	Classes: 09
I. C Engines: Four and two stroke engine, SI and CI engines, valve and port timing diagrams, fuel injection systems for SI engines, fuel injection systems for CI engines, ignition systems, cooling and lubrication system, fuel properties and combustion, stoichiometry.		
MODULE II	COMBUSTION IN SI AND CI ENGINES	Classes: 09
Combustion in SI engines and CI engines: Normal combustion and abnormal combustion, importance of flame speed and effect of engine variables, type of abnormal combustion, pre-ignition and knocking, fuel requirements and fuel rating, anti-knock additives, combustion chamber, requirements, types; Combustion in CI Engines: Four stages of combustion, delay period and its importance, effect of engine variables, diesel Knock, need for air movement, open and divided combustion chambers and nozzles used, fuel requirements and fuel rating		
MODULE III	TESTING AND PERFORMANCE,COMPRESSORS	Classes: 09
Testing and performance: Parameters of performance, measurement of cylinder pressure, fuel consumption, air intake, exhaust gas composition, brake power, determination of frictional losses and indicated power, performance test, heat balance sheet. and chart. Compressors: Classification, of compressors, fans, blower and compressor, positive displacement and dynamic types, reciprocating and rotary types.		
MODULE IV	ROTARY AND AXIAL CENTRIFUGAL COMPRESSORS	Classes: 09
Rotary, dynamic and axial flow (positive displacement): Roots blower, vane sealed compressor, mechanical details and principle of working efficiency considerations; Centrifugal compressors: mechanical details and principle of operation, velocity and Pressure variation, Energy transfer, impeller blade shape-losses, slip factor, and power input factor, pressure coefficient and adiabatic coefficient, velocity diagrams, power; Axial flow compressors: Mechanical details and principle of operation, velocity triangles and energy transfer per stage degree of reaction, work done factor, isentropic efficiency, pressure rise calculations, polytropic efficiency.		
MODULE V	REFRIGERATION	Classes: 09
Refrigeration: Mechanical refrigeration and types, units of refrigeration, air refrigeration system, details and principle of operation, applications of air refrigeration, vapour compression refrigeration systems, calculation of COP, effect of superheating and sub cooling, desired properties of refrigerants and common refrigerants, vapour absorption system, mechanical details, working principle, use of p-h charts for calculations.		
Text Books:		
1. V. Ganesan, "I.C. Engines", Tata McGraw-Hill, 3 rd Edition, 2011 2. B. John Heywood, "Internal Combustion Engine Fundamentals", Tata McGraw-Hill, 2 nd Edition,2011. 3. K. Rajput, "Thermal Engineering", Lakshmi Publications, 1 st Edition, 2011.		
Reference Books:		
1. Mathur, Sharma, "IC Engines", Dhanpat Rai& Sons, 3 rd Edition, 2008. 2. Pulkrabek, "Engineering Fundamentals of IC Engines", Pearson Education, 2 nd Edition, 2008. 3. Rudramoorthy, "Thermal Engineering", Tata McGraw-Hill, 5 th Edition 2003. 4. C. P. Arora, "Refrigeration and Air Conditioning", Tata McGraw-Hill Education, 3 rd Edition, 2013.		
Web References:		
1. http://www.uobabylon.edu.iq/uobColeges/ad_downloads/4_1293_515.pdf 2. http://ebooks.library.cornell.edu/k/kmoddl/toc_heywood1.html		

MODULE- I

IC ENGINES, FUEL INJECTION AND LUBRICATION SYSTEMS

Air-Standard Cycles

The operating cycle of an internal combustion engine can be broken down into a sequence of separate processes

- i. Intake
- ii. Compression
- iii. Combustion
- iv. Expansion
- v. Exhaust

The I.C engine does not operate on thermodynamic cycle as it involves an open system. The working fluid enters the system at one working set of condition and leaves at another set of condition

However, it is often possible to analyze the open cycle as though it were a closed one by imagining one (or) more process. That would bring the working fluid at the exit condition back to the condition of the starting point.

The accurate analysis of internal combustion engine processes is very complicated. In order to understand them it is advantageous to analyze the performance of an idealized closed cycle that closely approximates the real cycle.

One such approach is the air-standard cycle, which is based on the following assumptions.

1. The working medium is assumed to be a perfect gas $pV=mRT$
2. There is no change in the mass of working medium
3. All the processes that constitute the cycle are reversible
4. Heat is assumed to be supplied from a constant high temperature source and not from chemical reactions during the cycle.
5. Some heat is assumed to be rejected to a constant low temperature sink during the cycle.
6. It is assumed that there are no heat losses from the system to the surrounding
7. The working medium has constant Sp. Heat throughout the cycle.

The Carnot Cycle:

Working medium receives heat at a higher temperature and rejects heat at a low temperature the cycle will constitute of two reversible isothermal and two reversible adiabatic. It will give the concept of maximum work output between two temperature limits. Working principle:

- i. Cylinder and piston arrangement working without friction
- ii. Wall of cylinder are assumed to be perfect insulator
- iii. Cylinder head is so arranged that it can be a perfect heat conductor as well as perfect heat insulator

Analyzing the cycle thermodynamically the efficiency of the cycle can be written as

$$\eta_{\text{Carnot}} = \frac{\text{Work done by the system during the cycle (W)}}{\text{Heat supplied to the system during the cycle (Q)}}$$

Work done = Heat Supplied - Heat rejected

$$W = Q_S - Q_R$$

$$Q_S = mRT_1 \ln \frac{V_2}{V_1}$$

$$Q_R = mRT_3 \ln \frac{V_3}{V_4}$$

$$\frac{T_3}{T_2} = \left(\frac{V_2}{V_3}\right)^{(1-\gamma)} ; \frac{V_2}{V_3} = \left(\frac{T_3}{T_2}\right)^{\frac{1}{(1-\gamma)}}$$

$$\frac{T_4}{T_1} = \left(\frac{V_1}{V_4}\right)^{(1-\gamma)} ; \frac{V_1}{V_4} = \left(\frac{T_4}{T_1}\right)^{\frac{1}{(1-\gamma)}}$$

$$\frac{V_2}{V_3} = \frac{V_1}{V_4} ; \frac{V_2}{V_1} = \frac{V_3}{V_4} = r$$

$$\eta_{\text{Carnot}} = \frac{mRT_1 \ln \frac{V_2}{V_1} - mRT_3 \ln \frac{V_3}{V_4}}{mRT_1 \ln \frac{V_2}{V_1}} = \frac{mRT_1 \ln r - mRT_3 \ln r}{mRT_1 \ln r} = \frac{T_1 - T_3}{T_1} = 1 - \frac{T_3}{T_1}$$

Carnot cycle does not provide a suitable basis for the operation of an engine using a gaseous working fluid, because the work output from this cycle will be quite low. Mean effective pressure P_m is defined as the hypothetical constant pressure acting on the piston during its expansion stroke produce the same work output as that from the actual cycle.

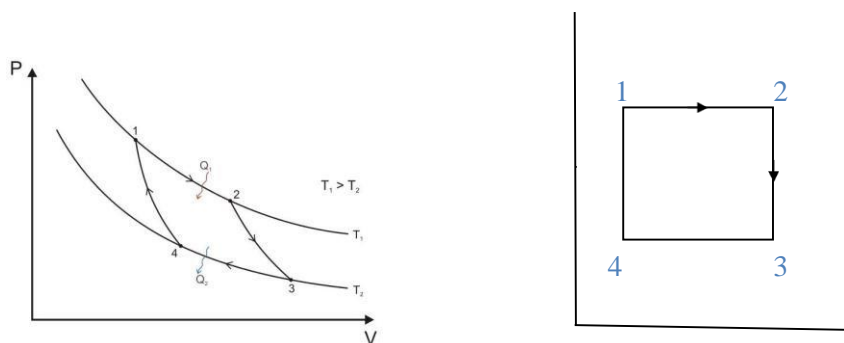

Stirling Cycle:

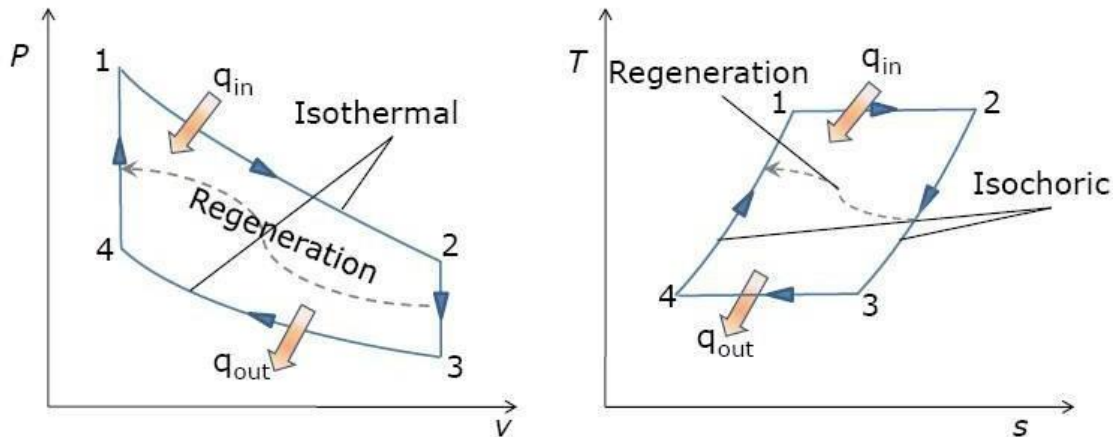

Consists of four totally reversible processes:

1-2 $T = \text{constant}$, expansion (heat addition from the external source)

2-3 $v = \text{constant}$, regeneration (internal heat transfer from the working fluid to the regenerator)

3-4 $T = \text{constant}$, compression (heat rejection to the external sink)

4-1 $v = \text{constant}$, regeneration (internal heat transfer from the regenerator back to the working fluid)

Ericsson Cycle:

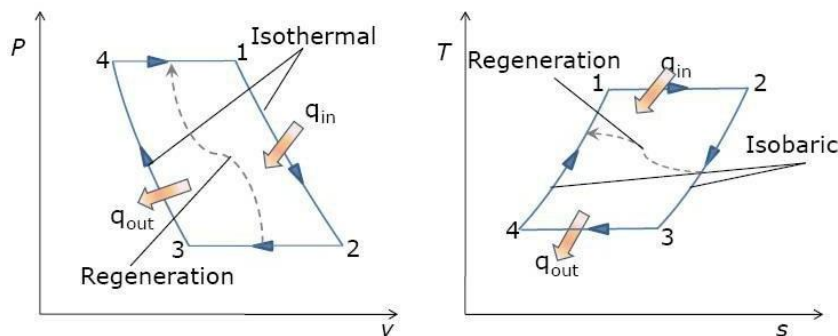

Ericsson cycle on $P-v$ and $T-s$ diagrams

Consists of four totally reversible processes:

1-2 $T = \text{constant}$, expansion (heat addition from the external source)

2-3 $P = \text{constant}$, regeneration (internal heat transfer from the working fluid to the regenerator)

3-4 $T = \text{constant}$, compression (heat rejection to the external sink)

4-1 $P = \text{constant}$, regeneration (internal heat transfer from the regenerator back to the working fluid)

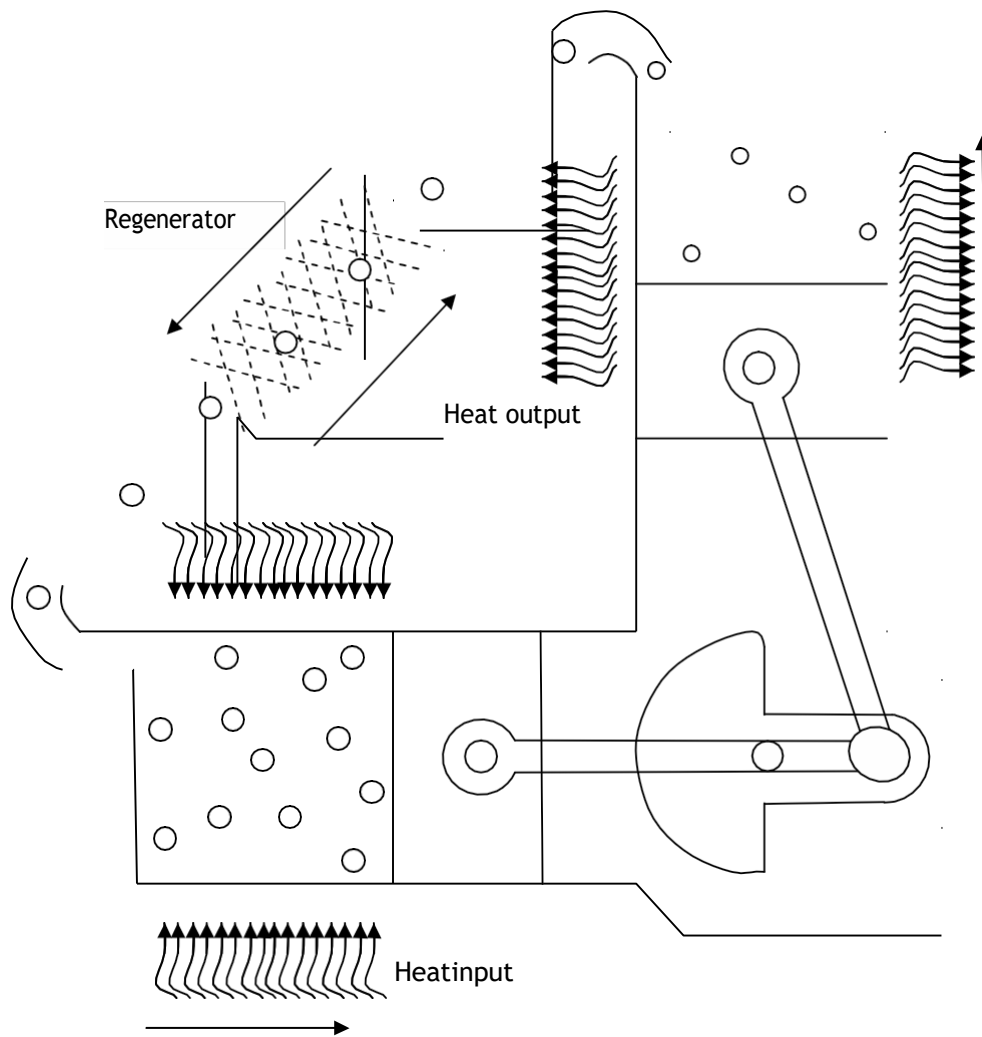
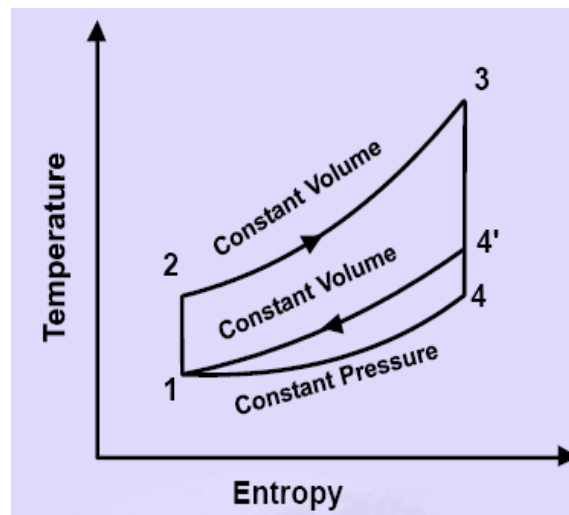
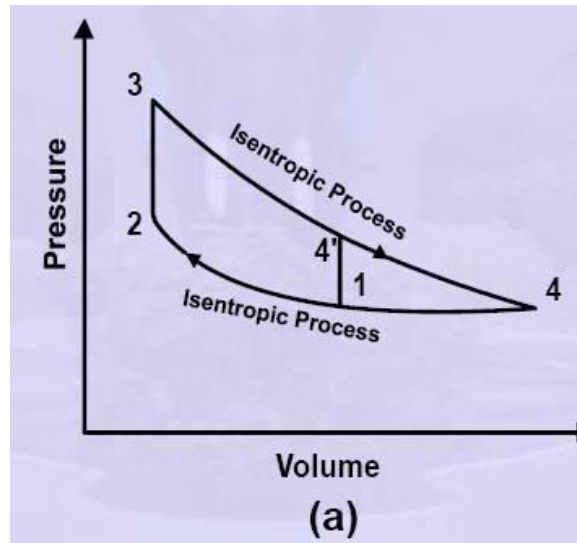

Fig Schematic view of Stirling engine

- Since both these engines are totally reversible cycles, their efficiencies equal the Carnot efficiency between same temperature limits.
- These cycles are difficult to realise practically, but offer great potential.
- Regeneration increases efficiency.
- This fact is used in many modern day cycles to improve efficiency.

Atkinson Cycle:



Atkinson cycle is an ideal cycle for Otto engine exhausting to a gas turbine. In this cycle the isentropic expansion (3-4) of an Otto cycle (1-2-3-4) is further allowed to proceed to the lowest cycle pressure so as to increase the work output. With this modification the cycle is known as Atkinson cycle.

Process 1-2: Reversible adiabatic compression (v_1 to v_2).

Process 2-3: Constant volume heat addition.

Process 3-4: Reversible adiabatic expansion (v_3 to v_4).

Process 4-1: Constant pressure heat rejection

Otto Cycle

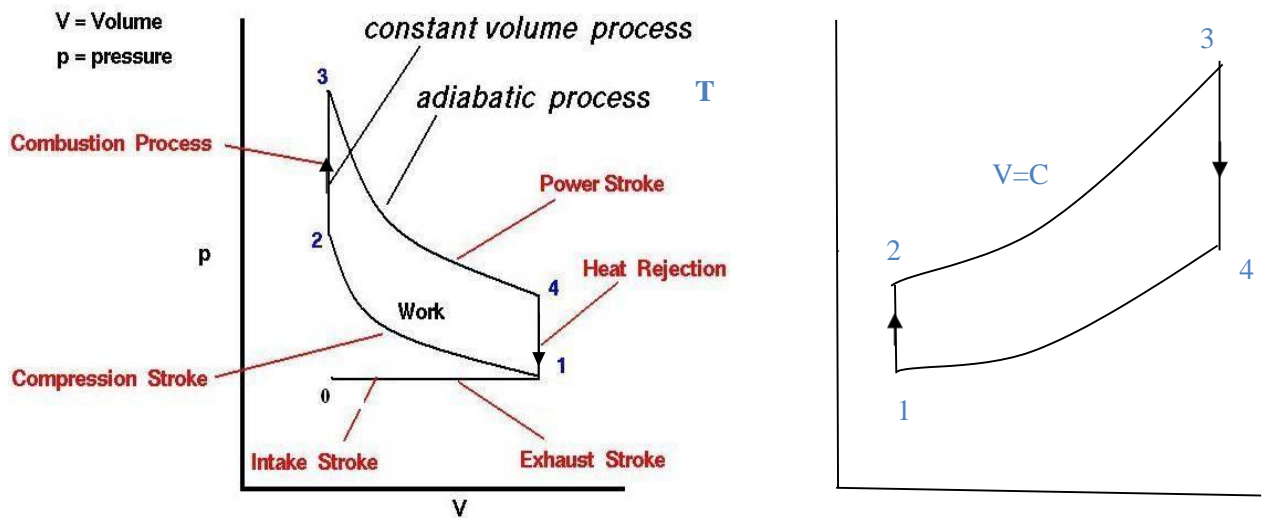

Nicolaus Otto (1876), proposed a constant-volume heat addition cycle which forms the basis for the working of today's spark-ignition engines.

$$\eta_{Otto} = \frac{\text{work done by the system during the cycle } (W)}{\text{Heat supplied to the system during the cycle } (Q_S)}$$

$$W = Q_S - Q_R$$

$$Q_S = mC_v(T_3 - T_2)$$

$$Q_R = mC_v(T_4 - T_1)$$

$$\eta_{Otto} = \frac{mC_v(T_3 - T_2) - mC_v(T_4 - T_1)}{mC_v(T_3 - T_2)} = 1 - \frac{T_4 - T_1}{T_3 - T_2} = 1 - \left(\frac{T_1}{T_2} \times \frac{\left(\frac{T_4}{T_1} - 1 \right)}{\left(\frac{T_3}{T_2} - 1 \right)} \right)$$

Consider isentropic processes 1-2 and 3-4

$$\frac{T_2}{T_1} = \frac{P_2}{P_1} \left(\frac{V_2}{V_1} \right) = \left(\frac{V_1}{V_2} \right)^\gamma \frac{v_2}{v_1} = \left(\frac{V_1}{V_2} \right)^{\gamma-1} = (r)^{\gamma-1}$$

$$\frac{T_3}{T_4} = \frac{P_3}{P_4} \left(\frac{V_3}{V_4} \right) = \left(\frac{V_4}{V_3} \right)^\gamma \frac{v_3}{v_4} = \left(\frac{V_4}{V_3} \right)^{\gamma-1} = (r)^{\gamma-1}$$

$$\frac{V_1}{V_2} = \frac{V_4}{V_3} = r; \quad \frac{T_2}{T_1} = \frac{T_3}{T_4}; \quad \frac{T_4}{T_1} = \frac{T_3}{T_2}$$

$$\eta_{Otto} = 1 - \frac{T_1}{T_2} = 1 - \frac{1}{\left(\frac{V_1}{V_2} \right)^{\gamma-1}} = 1 - \frac{1}{(r)^{\gamma-1}}$$

Note:

The thermal efficiency of Otto cycle is a function of compression ratio "r" and ratio of specific heats "γ".

As "γ" is assumed to be a constant for any working fluid the efficiency is increased with the compression ratio.

Efficiency is independent of heat supplied and pressure ratio.

The use of gases with higher “ γ ” values would increase efficiency of Otto cycle.

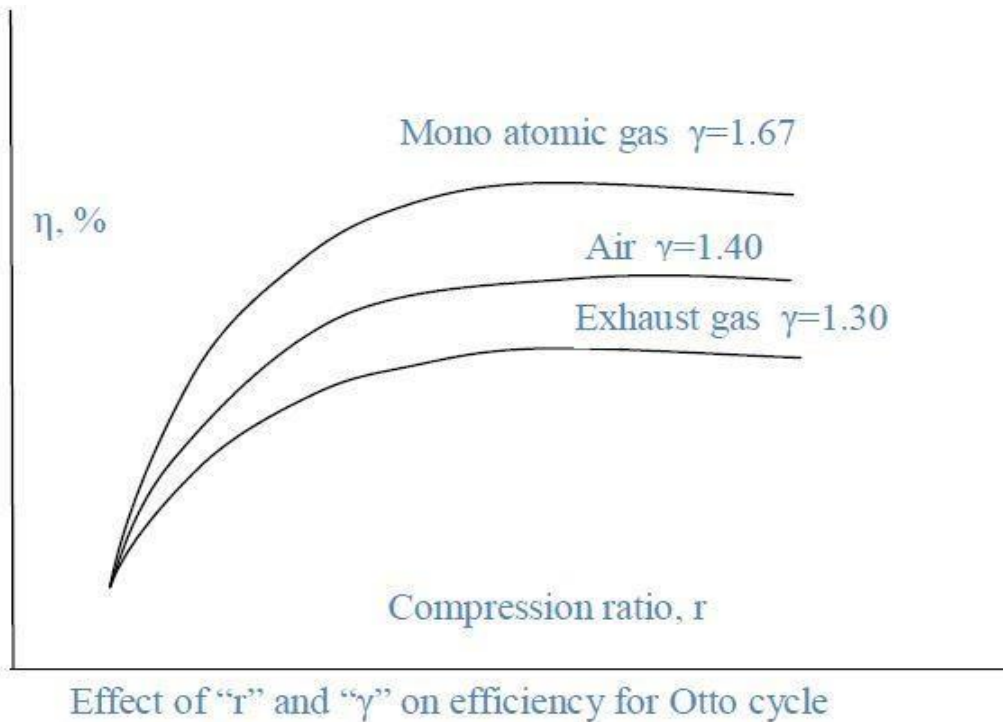

Work Output

The net work output for an Otto cycle can be expressed as

$$W = \frac{p_3 V_3 - p_4 V_4}{\gamma - 1} - \frac{p_2 V_2 - p_1 V_1}{\gamma - 1}$$

$$\frac{p_3}{p_2} = \frac{p_4}{p_1} = r_p; \quad \frac{V_1}{V_2} = \frac{V_4}{V_3} = r; \quad V_3 = V_2, V_4 = V_1$$

$$p_1 V_1^\gamma = p_2 V_2^\gamma = C; \quad p_3 V_3^\gamma = p_4 V_4^\gamma; \quad \frac{p_2}{p_1} = \frac{p_3}{p_4} = r^\gamma$$

$$W = \frac{p_1 V_1}{\gamma - 1} \left(\frac{p_3 V_3}{p_1 V_1} - \frac{p_4 V_4}{p_1 V_1} - \frac{p_2 V_2}{p_1 V_1} + 1 \right)$$

$$\frac{p_2 V_2}{p_1 V_1} = \frac{r^\gamma}{r} = r^{\gamma-1}$$

$$\frac{p_3 V_3}{p_1 V_1} - \frac{p_4 V_4}{p_1 V_1} = \frac{p_3 V_3}{p_1 r V_2} - \frac{p_4 r V_3}{p_1 r V_2} = \frac{V_3}{V_2} \left(\frac{p_3}{p_1 r} - \frac{p_4}{p_1} \right) = \frac{r_p p_2}{p_1 r} - r_p = \frac{r^\gamma r_p}{r} - r_p = r^{\gamma-1} r_p - r_p$$

$$W = \frac{p_1 V_1}{\gamma - 1} (r^{\gamma-1} r_p - r_p - r^{\gamma-1} + 1) = \frac{p_1 V_1}{\gamma - 1} (r^{\gamma-1} - 1)(r_p - 1)$$

Mean Effective Pressure

Mean effective pressure P_m is defined the hypothetical constant pressure acting on the piston during its expansion stroke produce the same work output as that from the actual cycle.

$$P_m = \frac{\text{workout}}{\text{swept volume}}$$

$$\text{swept volume} = V_1 - V_2 = V_2(r - 1)$$

$$P_m = \frac{\frac{p_1 V_1}{\gamma - 1} (r^{\gamma-1} - 1)(r_p - 1)}{V_2(r - 1)} = \frac{p_1 r (r^{\gamma-1} - 1)(r_p - 1)}{(r - 1)(\gamma - 1)}$$

Thus it can be seen that the work output is directly proportional to pressure ratio “ r_p ”. The mean effective pressure which is an indication of internal work output increases with a pressure ratio at a fixed value of compression ratio and ratio of specific heat.

Compression ratio

$$r = \frac{\text{volume before compression}}{\text{volume after compression}} = \frac{V_c + V_s}{V_c} > 1$$

Expansion ratio:

$$r_e = \frac{\text{volume after expansion}}{\text{volume before expansion}} > 1$$

Explosion ratio:

$$\alpha = r_p = \frac{\text{pressure after heat addition}}{\text{pressure before heat addition}} > 1$$

Example problems:

1. An engine working on Otto cycle has the following conditions. Pressure at the beginning of compression is 1 bar (initial temperature 17°C) and pressure at the end of compression is 15 bar. Calculate the compression ratio and air-standard efficiency of the engine. Assume $\gamma=1.4$
 $P_1= 1 \text{ bar (100 kN/m}^2)$ $P_2= 15 \text{ bar (1500 kN/m}^2)$, $\gamma=1.4$

$$p_1 V_1^\gamma = p_2 V_2^\gamma ; \frac{p_2}{p_1} = \frac{V_1^\gamma}{V_2^\gamma} = \left(\frac{V_1}{V_2}\right)^\gamma ; \frac{V_1}{V_2} = \left(\frac{p_2}{p_1}\right)^{\frac{1}{\gamma}} ; r = \left(\frac{p_2}{p_1}\right)^{\frac{1}{\gamma}} = \left(\frac{15}{1}\right)^{\frac{1}{1.4}} = 6.92$$

$$\eta_{\text{otto}} = 1 - \frac{1}{(r)^{\gamma-1}} = 1 - \frac{1}{(6.92)^{1.4-1}} = 53.9 \%$$

2. Heat is added at constant volume until the pressure rises to 40 bar. Mean effective pressure for the cycle assume $C_v=0.717 \text{ kJ/kgK}$ and $R=8.314 \text{ kJ/kmolK}$

$$\frac{T_2}{T_1} = \left(\frac{v_1}{v_2}\right)^{\gamma-1} = (6.92)^{1.4-1} = 2.17; T_2 = (273 + 17)2.17 = 629.3K$$

Consider process 2-3

$$\frac{p_2}{T_2} = \frac{p_3}{T_3}; \frac{T_3}{T_2} = \frac{p_3}{p_2}; T_3 = \frac{40}{15} \times 629.3 = 1678.13 K$$

Heat supplied

$$q_s = C_v(T_3 - T_2) = 0.717 \times (1678.13 - 629.3) = 752 \text{ kJ/kg}$$

$$\text{Work done} = \eta_{\text{otto}} \times q_s = 0.539 \times 752 = 405.33 \text{ kJ/kg}$$

$$P_m = \frac{\text{workout}}{\text{swept volume}}$$

$$V_1 = \frac{nRT_1}{p_1} = \frac{m RT_1}{M p_1} = \frac{1}{29} \times \frac{8314 \times 290}{1 \times 10^5} = 0.8314 \text{ m}^3/\text{kg}$$

$$V_1 - V_2 = V_1 \left(1 - \frac{1}{r}\right) = 0.8314 \times \frac{5.92}{6.92} = 0.711 \text{ m}^3/\text{kg}$$

$$P_m = \frac{405.33}{0.711} = 570 \text{ kN/m}^2 = 5.70 \text{ bar}$$

Diesel Cycle

In actual spark-ignition engines, the upper limit of compression ratio is limited by the self-ignition temperature of the fuel.

This limitation on compression ratio can be eliminated if air and fuel are compressed separately and brought together at the time of combustion.

In this cycle, heat is added at constant pressure instead of constant volume as in Otto cycle. This also consist of 4 processesnamely,

1. Reversible adiabaticcompression.
2. Reversible constant pressure heataddition
3. Reversible adiabaticexpansion
4. Reversible pressure heatrejection.

Process 1-2: Air inside the cylinder is compressed as piston moves from bottom dead centre (BDC) to top dead centre (TDC) adiabatically until its volume is reduced from V_1 to V_2 . Thus the pressure and temperature of air increases from P_1T_1 to P_2T_2 .

Process 2-3: From an external source heat is added. This heat addition will try to increase the temperature and pressure but as the piston moves from 2 to 3 the volume increases and pressure remains constant. This is treated as constant pressure heat addition. If we continue this heat addition the process 2-3 may continue until the piston reaches BDC hence leaving no scope to develop power. Thus after receiving certain specified volume the supply of heat is cut-off. Thus point 3 is known as cut-offpoint.

Process 3-4: The air which has gained energy is expanded adiabatically to BDC thus developing work. This stroke is called power stroke and the expansion continues till the piston reaches BDC.

Process 4-1: The cylinder is made to come in contact with a sink thus causing the rejection of heat instantaneously till the air reaches its initial state and completes the cycle

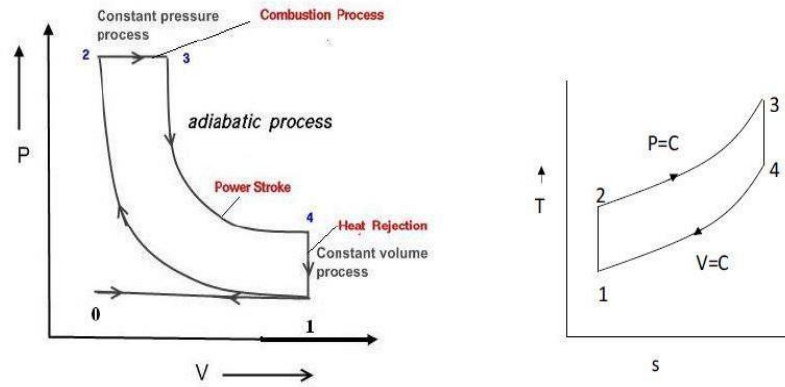

Cutoff ratio:

$$r_c = \frac{\text{volume after heat addition}}{\text{volume before heat addition}} > 1$$

$$\eta_{diesel} = \frac{Q_s - Q_r}{Q_s} = \frac{mC_p(T_3 - T_2) - mC_v(T_4 - T_1)}{mC_p(T_3 - T_2)} = 1 - \frac{C_v(T_4 - T_1)}{C_p(T_3 - T_2)} = 1 - \frac{1}{\gamma} \left(\frac{T_4 - T_1}{T_3 - T_2} \right)$$

Process 1-2

$$\frac{T_2}{T_1} = \left(\frac{V_1}{V_2} \right)^{\gamma-1} = (r)^{\gamma-1}; \quad T_2 = T_1(r)^{\gamma-1}$$

Process 2-3

$$\frac{V_2}{T_2} = \frac{V_3}{T_3}; \quad T_3 = \left(\frac{V_3}{V_2} \right) T_2; \quad T_3 = r_c T_2 = T_1(r)^{\gamma-1} r_c$$

Process 3-4

$$\frac{T_4}{T_3} = \left(\frac{V_3}{V_4} \right)^{\gamma-1} = \left(\frac{V_3 V_2}{V_2 V_4} \right)^{\gamma-1} = \left(\frac{r_c}{r} \right)^{\gamma-1}; \quad T_4 = T_3 \left(\frac{r_c}{r} \right)^{\gamma-1} = T_1(r)^{\gamma-1} r_c \left(\frac{r_c}{r} \right)^{\gamma-1} = T_1 r_c^\gamma$$

$$\begin{aligned} \eta_{diesel} &= 1 - \frac{1}{\gamma} \left(\frac{T_1 r_c^\gamma - T_1}{T_1(r)^{\gamma-1} r_c - T_1(r)^{\gamma-1}} \right) = 1 - \frac{1}{\gamma} \left(\frac{r_c^\gamma - 1}{(r)^{\gamma-1} r_c - (r)^{\gamma-1}} \right) \\ &= 1 - \frac{1}{\gamma} \left(\frac{r_c^\gamma - 1}{r^{\gamma-1} (r_c - 1)} \right) = 1 - \frac{1}{r^{\gamma-1}} \left(\frac{r_c^\gamma - 1}{\gamma (r_c - 1)} \right) \end{aligned}$$

The network output for an Otto cycle can be expressed as

$$\begin{aligned}
W &= p_2(V_3 - V_2) + \frac{p_3V_3 - p_4V_4}{\gamma - 1} - \frac{p_2V_2 - p_1V_1}{\gamma - 1} \\
W &= p_2V_2 \left(\frac{V_3}{V_2} - 1 \right) + \frac{p_3r_cV_2 - p_4rV_2}{\gamma - 1} - \frac{p_2V_2 - p_1rV_2}{\gamma - 1} \\
\frac{V_3}{V_2} &= r_c; V_3 = r_cV_2; V_4 = V_1 = rV_2; p_3 = p_2 \\
W &= \frac{V_2}{\gamma - 1} \left(p_2(r_c - 1)(\gamma - 1) + p_3 \left(r_c - \frac{p_4}{p_3} r \right) - p_2 \left(1 - \frac{p_1}{p_2} r \right) \right) \\
\frac{p_4}{p_3} &= \left(\frac{V_3}{V_4} \right)^\gamma = \left(\frac{V_3 V_2}{V_2 V_1} \right)^\gamma = \left(\frac{r_c}{r} \right)^\gamma; \frac{p_1}{p_2} = \left(\frac{1}{r} \right)^\gamma; \frac{p_2V_2}{T_2} = \frac{p_1V_1}{T_1}; p_2V_2 = p_1V_1 \left(\frac{T_2}{T_1} \right); p_2V_2 \\
&= p_1V_1(r)^{\gamma-1} \\
W &= \frac{p_2V_2}{\gamma - 1} \left((r_c - 1)(\gamma - 1) + \left(r_c - \left(\frac{r_c}{r} \right)^\gamma r \right) - \left(1 - \left(\frac{1}{r} \right)^\gamma r \right) \right) \\
W &= \frac{p_2V_2}{\gamma - 1} \left((r_c^\gamma - r_c - \gamma + 1) + (r_c - r_c^\gamma r^{1-\gamma}) - (1 - r^{1-\gamma}) \right) \\
W &= \frac{p_2V_2}{\gamma - 1} (\gamma(r_c - 1) - r_c + r_c - r^{1-\gamma}(r_c^\gamma - 1)) \\
W &= \frac{p_1V_1(r)^{\gamma-1}}{\gamma - 1} (\gamma(r_c - 1) - r^{1-\gamma}(r_c^\gamma - 1)) = \frac{p_1V_1}{\gamma - 1} (\gamma(r)^{\gamma-1}(r_c - 1) - (r_c^\gamma - 1))
\end{aligned}$$

Mean Effective Pressure

Mean effective pressure P_m is defined the hypothetical constant pressure acting on the piston during its expansion stroke produce the same work output as that from the actual cycle.

$$P_m = \frac{\text{workout}}{\text{swept volume}}$$

$$\text{swept volume} = V_1 - V_2 = V_1 \left(1 - \frac{1}{r}\right) = V_1 \left(\frac{r-1}{r}\right)$$

$$P_m = \frac{\frac{p_1 V_1}{\gamma-1} (\gamma(r)^{\gamma-1} (r_c - 1) - (r_c^\gamma - 1))}{V_1 \left(\frac{r-1}{r}\right)} = \frac{p_1 r (\gamma(r)^{\gamma-1} (r_c - 1) - (r_c^\gamma - 1))}{(\gamma-1)(r-1)}$$

Example problems:

1. A diesel engine works on Diesel cycle with a compression ratio of 15 and cut-off ratio of 1.75. Calculate the air-standard efficiency assuming $\gamma=1.4$.

$$\text{Solution: } \eta_{diesel} = 1 - \frac{1}{r^{\gamma-1}} \left(\frac{r_c^\gamma - 1}{\gamma(r_c - 1)} \right) = 1 - \frac{1}{15^{0.4}} \times \frac{1}{1.4} \times \left(\frac{1.75^{1.4} - 1}{1.75 - 1} \right) = 61.7 \%$$

2. A diesel engine is working with a compression ratio of 15 and expansion ratio of 10. Calculate the air-standard efficiency assuming $\gamma=1.4$.

$$\text{Solution: } \eta_{diesel} = 1 - \frac{1}{r^{\gamma-1}} \left(\frac{r_c^\gamma - 1}{\gamma(r_c - 1)} \right) = 1 - \frac{1}{15^{0.4}} \times \frac{1}{1.4} \times \left(\frac{1.75^{1.4} - 1}{1.75 - 1} \right) = 61.7 \%$$

$$r = \frac{V_1}{V_2}; r_e = \frac{V_4}{V_3}; r_c = \frac{V_3}{V_2}; V_4 = V_1; r_e = \frac{V_2 r}{V_2 r_c}; r_c = \frac{r}{r_e} = \frac{15}{10} = 1.5$$

$$\eta_{diesel} = 1 - \frac{1}{r^{\gamma-1}} \left(\frac{r_c^\gamma - 1}{\gamma(r_c - 1)} \right) = 1 - \frac{1}{15^{0.4}} \times \frac{1}{1.4} \times \left(\frac{1.5^{1.4} - 1}{1.5 - 1} \right) = 63 \%$$

Brayton Cycle

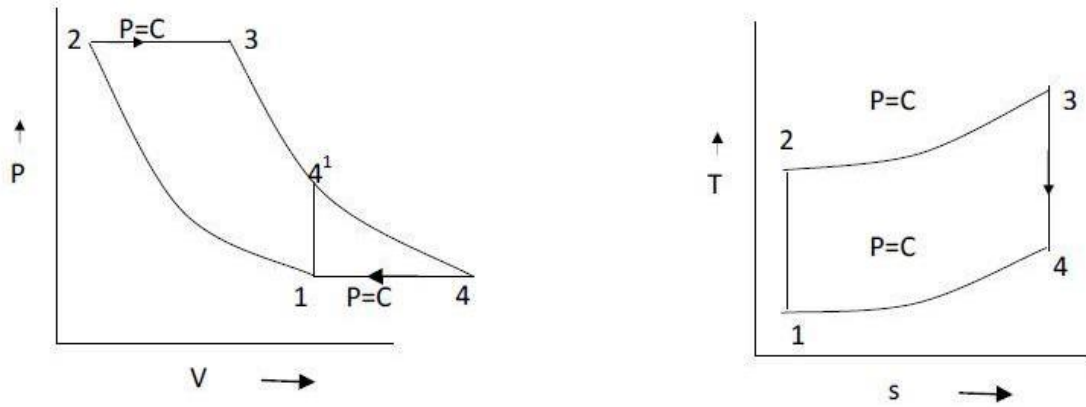

It is theoretical cycle for gas turbines. Constant pressure heat rejection.

$$\eta_{brayton} = \frac{Q_s - Q_r}{Q_s} = \frac{m C_p (T_3 - T_2) - m C_p (T_4 - T_1)}{m C_p (T_3 - T_2)} = 1 - \frac{T_4 - T_1}{T_3 - T_2}$$

$$\frac{T_2}{T_1} = \left(\frac{V_1}{V_2}\right)^{\gamma-1}; T_1 = \frac{T_2}{(r)^{\gamma-1}}$$

$$\frac{T_3}{T_4} = \left(\frac{p_3}{p_4}\right)^{\frac{\gamma-1}{\gamma}} = \left(\frac{p_2}{p_1}\right)^{\frac{\gamma-1}{\gamma}} = \left[\left(\frac{V_1}{V_2}\right)^{\gamma}\right]^{\frac{\gamma-1}{\gamma}} = \left(\frac{V_1}{V_2}\right)^{\gamma-1} = r^{\gamma-1}; T_4 = \frac{T_3}{(r)^{\gamma-1}}$$

$$\eta_{brayton} = 1 - \frac{\frac{T_3}{(r)^{\gamma-1}} - \frac{T_2}{(r)^{\gamma-1}}}{T_3 - T_2} = 1 - \frac{1}{(r)^{\gamma-1}} = 1 - \frac{1}{\left(\frac{p_2}{p_1}\right)^{\frac{\gamma-1}{\gamma}}} = 1 - \frac{1}{(r_p)^{\frac{\gamma-1}{\gamma}}}$$

Dual Cycle

In dual cycle a part of the heat is first supplied to the system at constant volume and then the remaining part at constant pressure

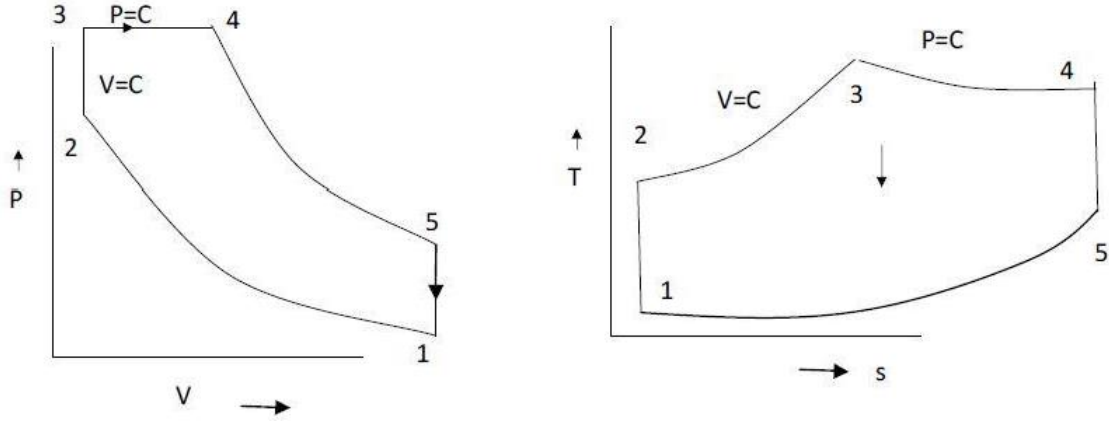

$$\eta_{dual} = \frac{Q_s - Q_r}{Q_s} = \frac{m C_v(T_3 - T_2) + m C_p(T_4 - T_3) - m C_v(T_5 - T_1)}{m C_v(T_3 - T_2) + m C_p(T_4 - T_3)}$$

$$= 1 - \frac{T_5 - T_1}{(T_3 - T_2) + \gamma(T_4 - T_3)}$$

$$\frac{T_2}{T_1} = \left(\frac{V_1}{V_2}\right)^{\gamma-1}; \quad T_2 = T_1 r^{\gamma-1}$$

$$\frac{T_3}{T_2} = \frac{p_3}{p_2}; \quad T_3 = T_2 \frac{p_3}{p_2} = T_2 r_p = T_1 r_p r^{\gamma-1}$$

$$\frac{T_4}{T_3} = \frac{V_4}{V_3} = r_c; \quad T_4 = T_3 r_c = T_1 r_c r_p r^{\gamma-1}$$

$$\frac{T_5}{T_4} = \left(\frac{V_4}{V_5}\right)^{\gamma-1}; \quad \frac{V_4}{V_5} = \frac{V_4}{V_1} = \frac{V_4}{V_3} \times \frac{V_3}{V_1} = \frac{V_4}{V_3} \times \frac{V_2}{V_1} = \frac{r_c}{r}; \quad V_3 = V_2$$

$$T_5 = T_4 \left(\frac{r_c}{r}\right)^{\gamma-1} = T_1 r_c r_p r^{\gamma-1} \left(\frac{r_c}{r}\right)^{\gamma-1} = T_1 r_c^\gamma r_p$$

$$\eta_{dual} = 1 - \frac{T_1 r_c^\gamma r_p - T_1}{(T_1 r_p r^{\gamma-1} - T_1 r^{\gamma-1}) + \gamma(T_1 r_c r_p r^{\gamma-1} - T_1 r_p r^{\gamma-1})}$$

$$= 1 - \frac{r_c^\gamma r_p - 1}{(r_p r^{\gamma-1} - r^{\gamma-1}) + \gamma(r_c r_p r^{\gamma-1} - r_p r^{\gamma-1})}$$

$$= 1 - \frac{1}{r^{\gamma-1}} \frac{r_c^\gamma r_p - 1}{(r_p - 1) + \gamma(r_c r_p - r_p)} = 1 - \frac{1}{r^{\gamma-1}} \frac{r_c^\gamma r_p - 1}{(r_p - 1) + \gamma r_p (r_c - 1)}$$

With $r_c=1$, it becomes an Otto cycle, and with $r_p=1$, it becomes a Diesel cycle.

Work output

$$\begin{aligned}
 W &= C_v[(T_3 - T_2) + \gamma(T_4 - T_3) - (T_5 - T_1)] \\
 &= C_v[(T_1 r_p r^{\gamma-1} - T_1 r^{\gamma-1}) + \gamma(T_1 r_c r_p r^{\gamma-1} - T_1 r_p r^{\gamma-1}) - (T_1 r_c^\gamma r_p - T_1)] \\
 &= C_v T_1 [(r_p r^{\gamma-1} - r^{\gamma-1}) + \gamma(r_c r_p r^{\gamma-1} - r_p r^{\gamma-1}) - (r_c^\gamma r_p - 1)] \\
 &= C_v T_1 [r^{\gamma-1}(r_p - 1) + \gamma r_p r^{\gamma-1}(r_c - 1) - (r_c^\gamma r_p - 1)] \\
 p_1 V_1 &= RT_1; \quad T_1 = \frac{p_1 V_1}{R} = \frac{p_1 V_1}{C_p - C_v} = \frac{p_1 V_1}{C_v \left(\frac{C_p}{C_v} - 1\right)} = \frac{p_1 V_1}{C_v(\gamma - 1)} \\
 &= \frac{p_1 V_1}{(\gamma - 1)} [r^{\gamma-1}(r_p - 1) + \gamma r_p r^{\gamma-1}(r_c - 1) - (r_c^\gamma r_p - 1)]
 \end{aligned}$$

Mean effective pressure

$$\begin{aligned}
 P_m &= \frac{W}{V_1 - V_2} = \frac{W}{V_1 \left(1 - \frac{1}{r}\right)} = \frac{rW}{V_1(r - 1)} \\
 &= \frac{r \frac{p_1 V_1}{(\gamma - 1)} [r^{\gamma-1}(r_p - 1) + \gamma r_p r^{\gamma-1}(r_c - 1) - (r_c^\gamma r_p - 1)]}{V_1(r - 1)} \\
 &= \frac{p_1 r}{(\gamma - 1)(r - 1)} [r^{\gamma-1}(r_p - 1) + \gamma r_p r^{\gamma-1}(r_c - 1) - (r_c^\gamma r_p - 1)]
 \end{aligned}$$

Comparison of the Otto, Diesel and Dual Cycles

The important variable factors which are used as the basis for comparison of the cycle are compression ratio, peak pressure, heat addition, heat rejection, and the net work.

1. Same Compression Ratio and Heat Addition:

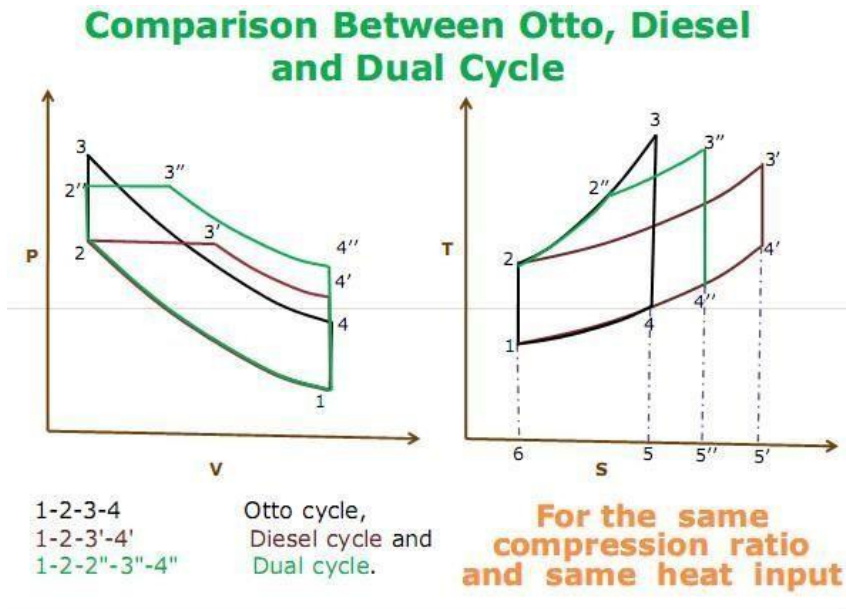

All the cycles start from the same initial state points 1 and air is compressed from state 1 to 2 as the compression ratio is same. From the T-s same heat input for the three cycles are same and heat rejection is low for Otto cycle and high for Diesel cycle.

$$\eta_{\text{Otto}} > \eta_{\text{Dual}} > \eta_{\text{Diesel}}$$

Otto cycle allows the working medium to expand more whereas Diesel cycle is least in this respect.

2. Same Compression Ratio and Heat Rejection

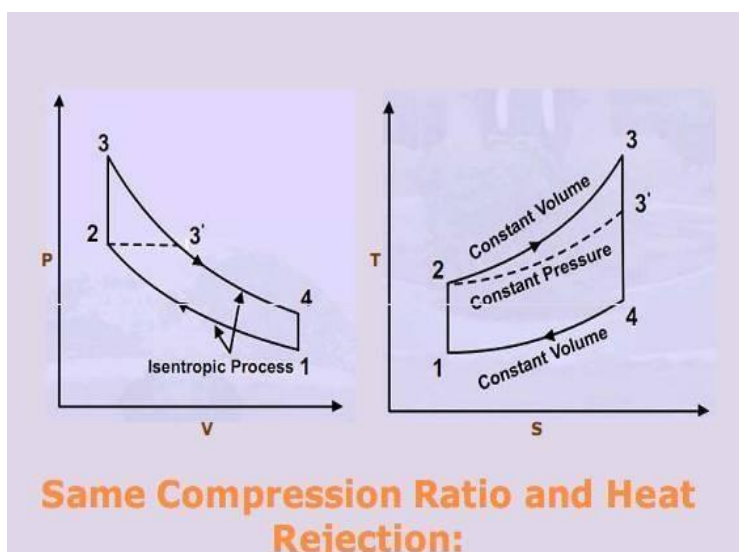

Heat supplied in Otto cycle is more compared to Diesel Cycle. The heat rejection and Compression ratio is same.

$$\eta_{\text{Otto}} > \eta_{\text{Dual}} > \eta_{\text{Diesel}}$$

3. Same Peak Pressure, Peak Temperature and Heat Rejection.

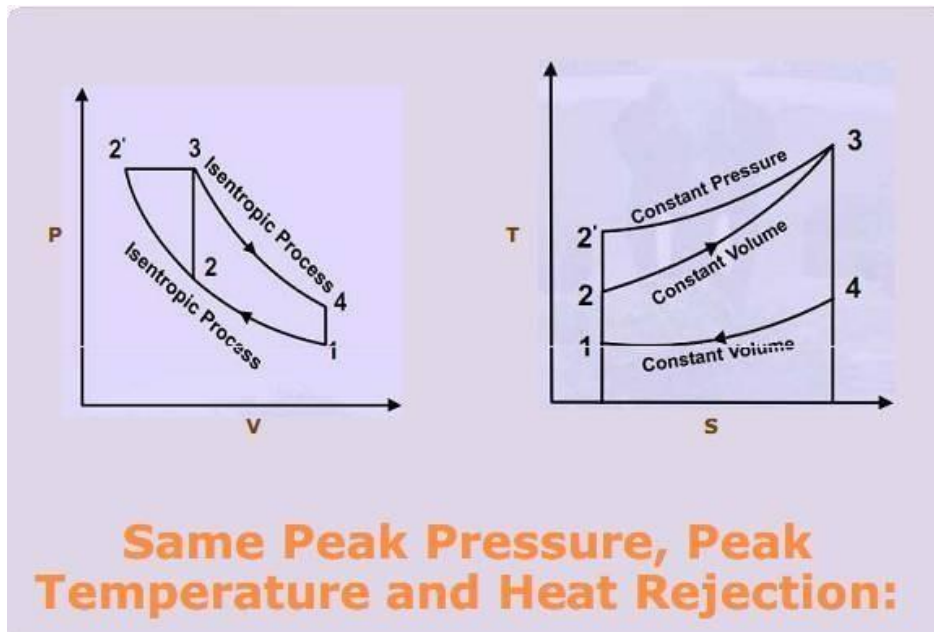

Heat supplied in Diesel Cycle is more compared to Otto cycle. The heat rejections, Peak Pressure, Peak Temperature are same

$$\eta_{\text{Diesel}} > \eta_{\text{Dual}} > \eta_{\text{Otto}}$$

4. Same Maximum Pressure and Heat Input.

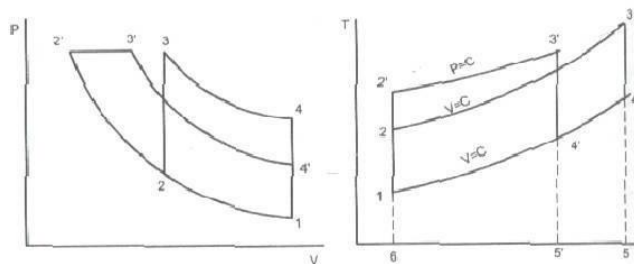

For the same Maximum pressure and same heat input

Heat rejection in Diesel Cycle is less compared to Otto cycle. The heat input, and Peak Pressure are same.

$$\eta_{\text{Diesel}} > \eta_{\text{Dual}} > \eta_{\text{Otto}}$$

5. Same Maximum Pressure and Work Output

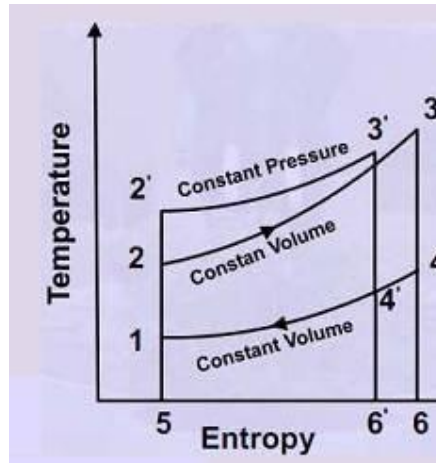

Heat rejection in Diesel Cycle is less compared to Otto cycle. The heat input, and Peak Pressure are same.

$$\eta_{\text{Diesel}} > \eta_{\text{Dual}} > \eta_{\text{Otto}}$$

IC Engines

Over the centuries a wide array of devices and systems has been developed for this purpose. Some of these energy converters are quite simple. The early windmills, for example, transformed the kinetic energy of wind into mechanical energy for pumping water and grinding grain. Other energy-conversion systems are decidedly more complex, particularly those that take raw energy from fossil fuels and nuclear fuels to generate mechanical energy/electricity. Systems of this kind require multiple steps or processes in which energy undergoes a whole series of transformations through various intermediate forms.

The machine which does this job of energy conversion is called an engine. Engine:

An **engine** is a machine designed to convert one form of energy into another form of energy. Normally most of the engines convert thermal energy into mechanical work and therefore they are called ‘heat engines’

Heat Engine:

Heat engine is a device which transforms the chemical energy of fuel into thermal energy and utilizes this thermal energy to perform useful work.

1. Internal Combustion Engine.
2. External Combustion Engine

Basic Engine Components

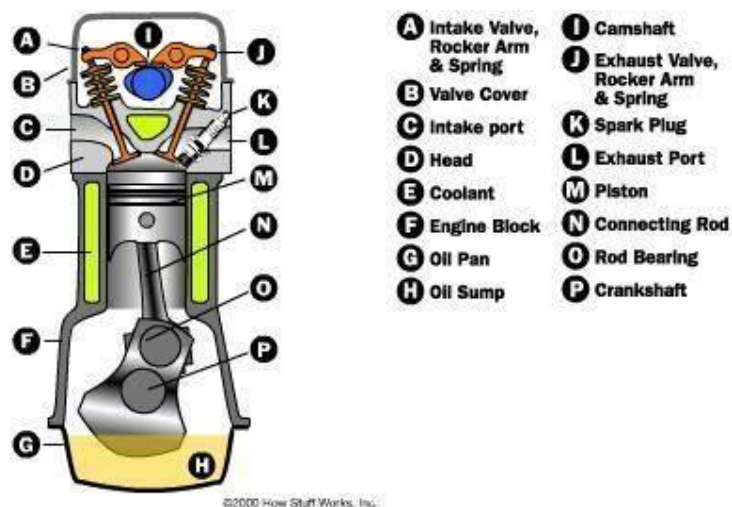

1. Cylinderblock

Cylinder is the main body of IC engine. Cylinder is a part in which the intake of fuel, compression of fuel and burning of fuel take place. The main function of cylinder is to guide the piston. It is in direct contact with the products of combustion so it must be cooled. For cooling of cylinder a water jacket (for liquid cooling used in most of cars) or fin (for air cooling used in most of bikes) are situated at the outer side of cylinder.



2. Cylinderhead

The top end of cylinder is closed by means of removable cylinder head. There are two holes or ports at the cylinder head, one for intake of fuel and other for exhaust. Both the intake and exhaust ports are closed by the two valves known as inlet and exhaust valve. The inlet valve, exhaust valve, spark plug, injector etc. are bolted on the cylinder head. The main function of cylinder head is to seal the cylinder block and not to permit entry and exit of gases on cover head valve engine.



3. Piston

A piston is fitted to each cylinder as a face to receive gas pressure and transmit the thrust to the connecting rod. It is the prime mover in the engine. The main function of piston is to give tight seal to the cylinder through bore and slide freely inside of cylinder. Piston should be light and sufficient strong to handle the gas pressure generated by combustion of fuel. So the piston is made by aluminum alloy and sometimes it is made by cast iron because light alloy piston expands more than cast iron so they need more clearances to the bore.



4. Pistonrings

A piston must be a fairly loose fit in the cylinder so it can move freely inside the cylinder. If the piston is too tight fit, it would expand as it got hot and might stick tight in the cylinder and if it is too loose it would leak the vapor pressure. To provide a good sealing fit and less friction resistance between the piston and cylinder, pistons are equipped with piston rings. These rings are fitted in grooves which have been cut in the piston. They are split at one end so they can expand or slip over the end of piston. A small two stroke engine has two piston rings to provide good sealing but in a four stroke engine has an extra ring which is known as oil ring. Piston rings are made of cast iron of fine grain and high elastic material which is not affected by the working heat. Sometimes it is

made by alloy spring steel.



5. Connectingrod

Connecting rod connects the piston to crankshaft and transmits the motion and thrust of piston to crankshaft. It converts the reciprocating motion of the piston into rotary motion of crankshaft. There are two end of connecting rod one is known as big end and other as small end. Big end is connected to the crankshaft and the small end is connected to the piston by use of piston pin. The connecting rods are made of nickel, chrome, and chrome vanadium steels. For small engines the material may be aluminum.



6. Crankshaft

The crankshaft of an internal combustion engine receives the efforts or thrust supplied by piston to the connecting rod and converts the reciprocating motion of piston into rotary motion of crankshaft. The crankshaft mounts in bearing so it can rotate freely. The shape and size of crankshaft depends on the number and arrangement of cylinders. It is usually made by steel forging, but some makers use special types of cast-iron such as nickel alloy castings which are cheaper to produce and have good service life.



7. Crankcase

The main body of the engine to which the cylinder are attached and which contains the crankshaft and crankshaft bearing is called crankcase. It serves as the lubricating system too and sometime it is called oil sump. All the oil for lubrication is placed init.



8. Valves

To control the inlet and exhaust of internal combustion engine, valves are used. The number of valves in an engine depends on the number of cylinders. Two valves are used for each cylinder one for inlet of air-fuel mixture inside the cylinder and other for exhaust of combustion gases. The valves are fitted in the port at the cylinder head by use of strong spring. This spring keep them closed. Both valves usually openinwards.



9. Camshaft

Camshaft is used in IC engine to control the opening and closing of valves at proper timing. For proper engine output inlet valve should open at the end of exhaust stroke and closed at the end of intake stroke. So to regulate its timing, a cam is use which is oval in shape and it exerts a pressure on the valve to open and release to close. It is drive by the timing belt which drives by crankshaft. It is placed at the top or at the bottom of cylinder.



10. Gudgeon pin or pistonpin

These are hardened steel parallel spindles fitted through the piston bosses and the small end bushes or eyes to allow the connecting rods to swivel. It connects the piston to connecting rod. It is made hollow for lightness.



11. Pushrod

Pushrod is used when the camshaft is situated at the bottom end of cylinder. It carries the camshaft motion to the valves which are situated at the cylinder head.



12. Manifold

The main function of manifold is to supply the air fuel mixture and collects the exhaust gases equally from all cylinder. In an internal combustion engine two manifold are used, one for intake and other for exhaust. They are usually made by aluminum alloy.



13. Sparkplug

It is used in spark ignition engine. The main function of a spark plug is to conduct the high potential from the ignition system into the combustion chamber to ignite the compressed air fuel mixture. It is fitted on cylinder head. The spark plug consists of a metal shell having two electrodes which are insulated from each other with an air gap. When high potential current supply to spark plug it jumping from the supply electrode and produces the necessary spark.



14. Injector

Injector is usually used in compression ignition engine. It sprays the fuel into combustion chamber at the end of compression stroke. It is fitted on cylinder head.

15. Flywheel

The net torque imparted to the crankshaft during one complete cycle of operation of the engine fluctuates causing a change in the angular velocity of the shaft. In order to achieve a uniform torque an inertia mass in the form of a wheel is attached to the output shaft and this wheel is called the flywheel.

Nomenclature:

Cylinder Bore (d): The nominal inner diameter of the working cylinder is called the cylinder bore. (mm)

Piston Area (A): The area of a circle of diameter equal to the cylinder bore (cm^2)

Stroke (L): The nominal distance through which a working piston moves between two successive reversals of its direction of motion.

Dead Centre: The position of the working piston and the moving parts which are mechanically connected to it, at the moment when the direction of the piston motion is reversed at either end of the stroke is called the dead centre.

Top Dead Centre (TDC): It is the dead centre when the piston is extreme from the crankshaft. *Bottom Dead Centre (BDC)*: It is the dead centre when the piston is nearest to the crankshaft

Clearance Volume (V_C): The nominal volume of the combustion chamber above the piston when it is at the top dead centre.

Compression Ratio (r): It is the ratio of the total cylinder volume when the piston is at the bottom dead centre (V_T), to the clearance volume, V_C

$$r = V_T / V_C$$

Four Stroke Spark Ignition Engine

Petrol engines are also known as spark-ignition (S.I.) engines. Petrol engines take in a flammable mixture of air and petrol which is ignited by a timed spark when the charge is compressed. The first four stroke spark-ignition (S.I.) engine was built in 1876 by Nicolaus August Otto.

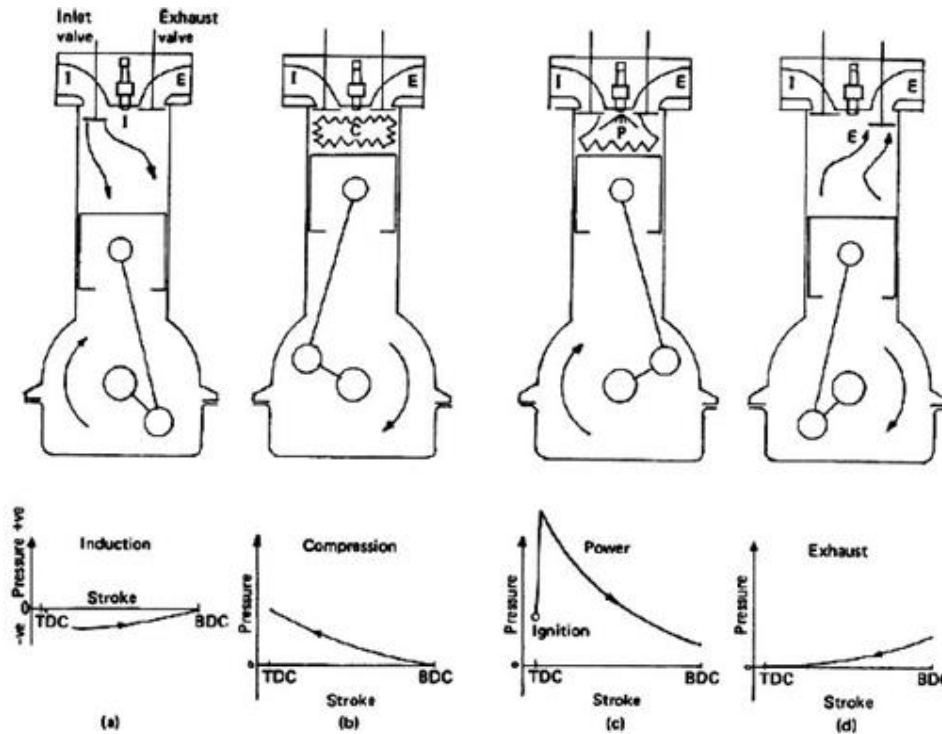

Four stroke Spark-ignition (S.I) engines require four piston strokes to complete one cycle or two revolutions of the crankshaft. During the four strokes, there are five events to be completed (i) suction, compression, combustion, expansion and exhaust. An air-and-fuel intake stroke moving outward from the cylinder head, an inward movement towards the cylinder head compressing the charge, an outward power stroke, and an inward exhaust stroke.

Suction stroke/Intake stroke: The inlet valve is opened and the exhaust valve is closed. The piston is at top dead centre and about to move downwards. Due to the suction created by the motion of the piston towards the bottom dead centre. The suction actually generated will depend on the speed and load experienced by the engine, but a typical average value might be 0.12 bar below atmospheric pressure. When the piston reaches the bottom dead centre the suction stroke ends and the inlet valve closes.

Compression stroke: Both the inlet and the exhaust valves are closed. The piston begins to return stroke towards the cylinder head. The induced air-and-petrol charge is progressively compressed into clearance volume (something of the order of one-eighth to one-tenth of the cylinder's original

volume at the piston's innermost position). This compression squeezes the air and atomized-petrol molecules closer together and not only increases the charge pressure in the cylinder but also raises the temperature (Typical maximum cylinder compression pressures will range between 8 and 14 bar with the throttle open and the engine running underload).

Combustion stroke: At the end of compression stroke the mixture is ignited with the help of spark-plug. In an ideal engine it is assumed that burning takes place instantaneously when the piston is at to dead centre and hence the burning process can be approximated as heat addition at the constant volume. During the burning process the chemical energy of the fuel is converted into heat energy producing a temperature rise of about 2000 °C. the pressure at the end of the combustion process is considerably increased due to the heat released from the fuel.

Power stroke (or) Expansion: Both the inlet and the exhaust valves are closed and, the burning gases then expand and so change the piston's direction of motion and push it to its bottom dead centre. Of the four stroke this stroke power is produced. The cylinder pressure and temperature both will decrease during the expansion.

Exhaust stroke: At the end of the power stroke the inlet valve remains closed but the exhaust valve is opened. The piston changes its direction of motion and now moves from the bottom dead centre to the top dead centre. Most of the burnt gases will be escape by the existing pressure energy of the gas, but the returning piston will push the last of the spent gases out of the cylinder through the exhaust-valve port and to the atmosphere. During the exhaust stroke, the gas pressure in the cylinder will fall from the exhaust-valve opening pressure (which may vary from 2 to 5 bar, depending on the engine speed and the throttle-opening position) to atmospheric pressure or even less as the piston nears the innermost position towards the cylinder head. At the end of the exhaust stroke and some residual gases trapped in the clearance volume remain in the cylinder.

Two Stroke Spark Ignition Engine

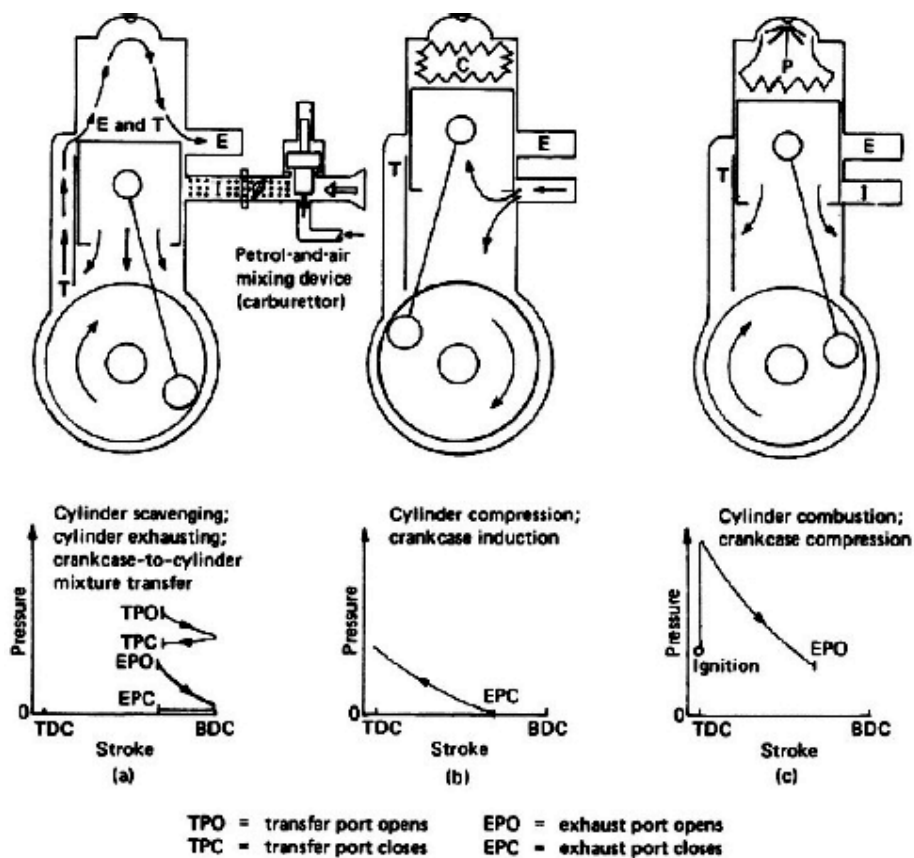

Two unproductive strokes the suction and exhaust could be served by an alternative arrangement, especially without movement of the piston then there will be a power stroke for each revolution of the crankshaft.

The first successful design of a three-port two-stroke Spark-ignition (S.I) engine was invented Dugald Clark (1878) and patented in 1889 by Joseph Day & Son of Bath. This employed the underside of the piston in conjunction with a sealed crank-case to form a scavenge pump ('scavenging' being the pushing-out of exhaust gas by the induction of freshcharge)

The two stroke spark-ignition (S.I) engine completes the cycle of events - suction, compression, power, and exhaust - in one revolution of the crankshaft or two complete piston strokes.

Crankcase-to-cylinder mixture transfer: The piston moves down the cylinder and initially uncovers the exhaust port, releasing the burnt exhaust gases to the atmosphere. Simultaneously the downward movement of the underside of the piston compresses the previously filled mixture of air and atomized petrol in the crankcase. Further outward movement of the piston will uncover the transfer port (T), and the compressed mixture in the crankcase will then be transferred to the combustion-chamber side of the cylinder. The situation in the cylinder will then be such that the freshcharge entering the cylinder will push out any remaining burnt products of combustion - this

process is generally referred to as cross-flow scavenging.

Cylinder compression and crankcase suction: The crankshaft rotates, moving the piston in the direction of the cylinder head. Initially the piston seals off the transfer port, and then a short time later the exhaust port will be completely closed. Further inward movement of the piston will compress the mixture of air and atomized petrol to about one-seventh to one-eighth of its original volume.

At the same time as the fresh charge is being compressed between the combustion chamber and the piston head, the inward movement of the piston increases the total volume in the crank-case so that a depression is created in this space. About half-way up the cylinder stroke, the lower part of the piston skirt will uncover the inlet port (I), and a fresh mixture of air and petrol prepared by the carburetor will be inducted into the crank-case chamber.

Cylinder combustion and crankcase compression: Just before the piston reaches the top of its stroke, a spark-plug situated in the centre of the cylinder head will be timed to spark and ignite the dense mixture. The burning rate of the charge will rapidly raise the gas pressure to a maximum (of about 50 bar under full load). The burning mixture then expands, forcing the piston back along its stroke with a corresponding reduction in cylinder pressure.

Considering the condition underneath the piston in the crankcase, with the piston initially at the top of its stroke, fresh mixture will have entered the crankcase through the inlet port. As the piston moves down its stroke, the piston skirt will cover the inlet port, and any further downward movement will compress the mixture in the crankcase in preparation for the next charge transfer into the cylinder and combustion-chamber space.

Difference between Two & Four Stroke Cycle Petrol Engines

The differences between two- and four-stroke-cycle petrol engines regarding the effectiveness of both engine cycles are given below:

- a) The two-stroke engine completes one cycle of events for every revolution of the crankshaft, compared with the two revolutions required for the four-stroke engine cycle.
- b) Theoretically, the two-stroke engine should develop twice the power compared to a four-stroke engine of the same cylinder capacity.
- c) In practice, the two-stroke engine's expelling of the exhaust gases and filling of the cylinder with fresh mixture brought in through the crankcase is far less effective than having separate exhaust and induction strokes. Thus the mean effective cylinder pressures in two-stroke units are far lower than in equivalent four-stroke engines.

- d)** With a power stroke every revolution instead of every second revolution, the two-stroke engine will run smoother than the four-stroke power unit for the same size offlywheel.
- e)** Unlike the four-stroke engine, the two-stroke engine does not have the luxury of separate exhaust and induction strokes to cool both the cylinder and the piston between power strokes. There is therefore a tendency for the piston and small-end to overheat under heavy driving conditions.
- f)** Due to its inferior scavenging process, the two-stroke engine can suffer from the following:
 - i)* inadequate transfer of fresh mixture into the cylinder,
 - ii)* excessively large amounts of residual exhaust gas remaining in the cylinder,
 - iii)* direct expulsion of fresh charge through the exhaust port. These undesirable conditions may occur under different speed and load situations, which greatly influences both power and fuel consumption.
- g)** Far less maintenance is expected with the two-stroke engine compared with the four-stroke engine, but there can be a problem with the products of combustion carburizing at the inlet, transfer, and exhaust ports.
- h)** Lubrication of the two-stroke engine is achieved by mixing small quantities of oil with petrol in proportions anywhere between 1:16 and 1:24 so that, when crankcase induction takes place, the various rotating and reciprocating components will be lubricated by a petrol-mixture mist. Clearly a continuous proportion of oil will be burnt in the cylinder and expelled into the atmosphere to add to unwanted exhaust emission.
- i)** There are fewer working parts in a two-stroke engine than in a four-stroke engine, so two-stroke engines are generally cheaper to manufacture.

Four Stroke Compression Ignition Engine

Compression-ignition (C.I) engines burn fuel oil which is injected into the combustion chamber when the air charge is fully compressed. Burning occurs when the compression temperature of the air is high enough to spontaneously ignite the finely atomized liquid fuel. In other words, burning is initiated by the self-generated heat of compression. Compression- ignition (C.I) engines are also referred to as 'oil engines', due to the class of fuel burnt, or as 'diesel engines' after Rudolf Diesel, one of the many inventors and pioneers of the early C.I. engine.

Just like the four-stroke-cycle petrol engine, the Compression-ignition (C.I.) engine completes one cycle of events in two crankshaft revolutions or four piston strokes. The four phases of these strokes are (i) suction of fresh air, (ii) compression and heating of this air, (iii) injection of fuel and its burning and expansion, and (iv) expulsion of the products of combustion.

Suction Stroke With the inlet valve open and the exhaust valve closed, the piston moves away from the cylinderhead.

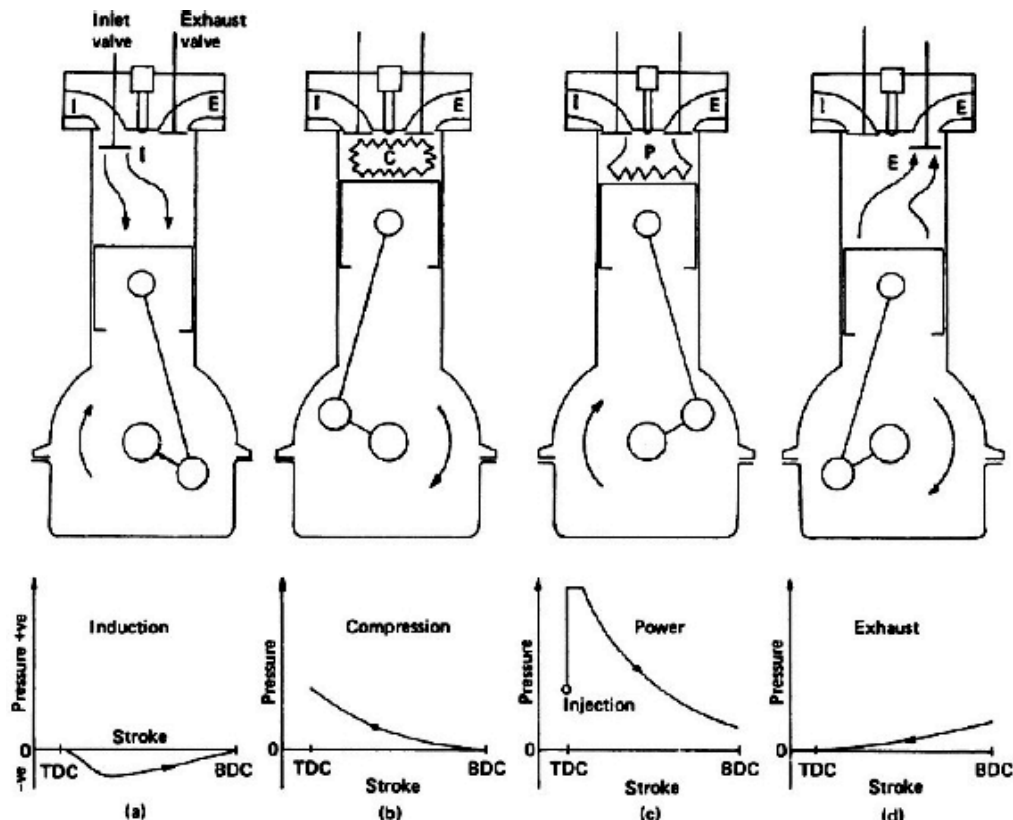

The outward movement of the piston will establish a depression in the cylinder, its magnitude depending on the ratio of the cross-sectional areas of the cylinder and the inlet port and on the speed at which the piston is moving. The pressure difference established between the inside and outside of the cylinder will induce air at atmospheric pressure to enter and fill up the cylinder. Unlike the petrol engine, which requires a charge of air-and-petrol mixture to be drawn past a throttle valve, in the

diesel-engine inlet system no restriction is necessary and only pure air is induced into the cylinder. A maximum depression of maybe 0.15 bar below atmospheric pressure will occur at about one-third of the distance along the piston's outward stroke, while the overall average pressure in the cylinder might be 0.1 bar or even less.

Compression stroke: With both the inlet and the exhaust valves closed, the piston moves towards the cylinder head. The air enclosed in the cylinder will be compressed into a much smaller space of anything from 1/12 to 1/24 of its original volume. A typical ratio of maximum to minimum air-charge volume in the cylinder would be 16:1, but this largely depends on engine size and designed speed range.

During the compression stroke, the air charge initially at atmospheric pressure and temperature is reduced in volume until the cylinder pressure is raised to between 30 and 50 bar. This compression of the air generates heat which will increase the charge temperature to at least 600 °C under normal running conditions.

Power stroke: With both the inlet and the exhaust valves closed and the piston almost at the end of the compression stroke, diesel fuel oil is injected into the dense and heated air as a high-pressure spray of fine particles. Provided that they are properly atomized and distributed throughout the air charge, the heat of compression will then quickly vaporize and ignite the tiny droplets of liquid fuel. Within a very short time, the piston will have reached its innermost position and extensive burning then releases heat energy which is rapidly converted into pressure energy. Expansion then follows, pushing the piston away from the cylinder head, and the linear thrust acting on the piston end of the connecting-rod will then be changed to rotary movement of the crankshaft.

Exhaust stroke: When the burning of the charge is near completion and the piston has reached the outermost position, the exhaust valve is opened. The piston then reverses its direction of motion and moves towards the cylinder head. The sudden opening of the exhaust valve towards the end of the power stroke will release the still burning products of combustion to the atmosphere. The pressure energy of the gases at this point will accelerate their expulsion from the cylinder, and only towards the end of the piston's return stroke will the piston actually catch up with the tail-end of the outgoing gases.

Two Stroke Compression Ignition Engine

The pump scavenge two stroke diesel engine designed by Sir Dugald Clerk in 1879 was the first successful two-stroke engine; thus the two-stroke-cycle engine is sometimes called the Clerk engine. Unit-flow scavenging took place - fresh charge entering the combustion chamber above the piston while the exhaust outflow occurred through ports uncovered by the piston at its outermost position.

Low- and medium-speed two-stroke marine diesels engines still use this system, but high- speed two-stroke diesel engines reverse the scavenging flow by blowing fresh charge through the bottom inlet ports, sweeping up through the cylinder and out of the exhaust ports in the cylinder head.

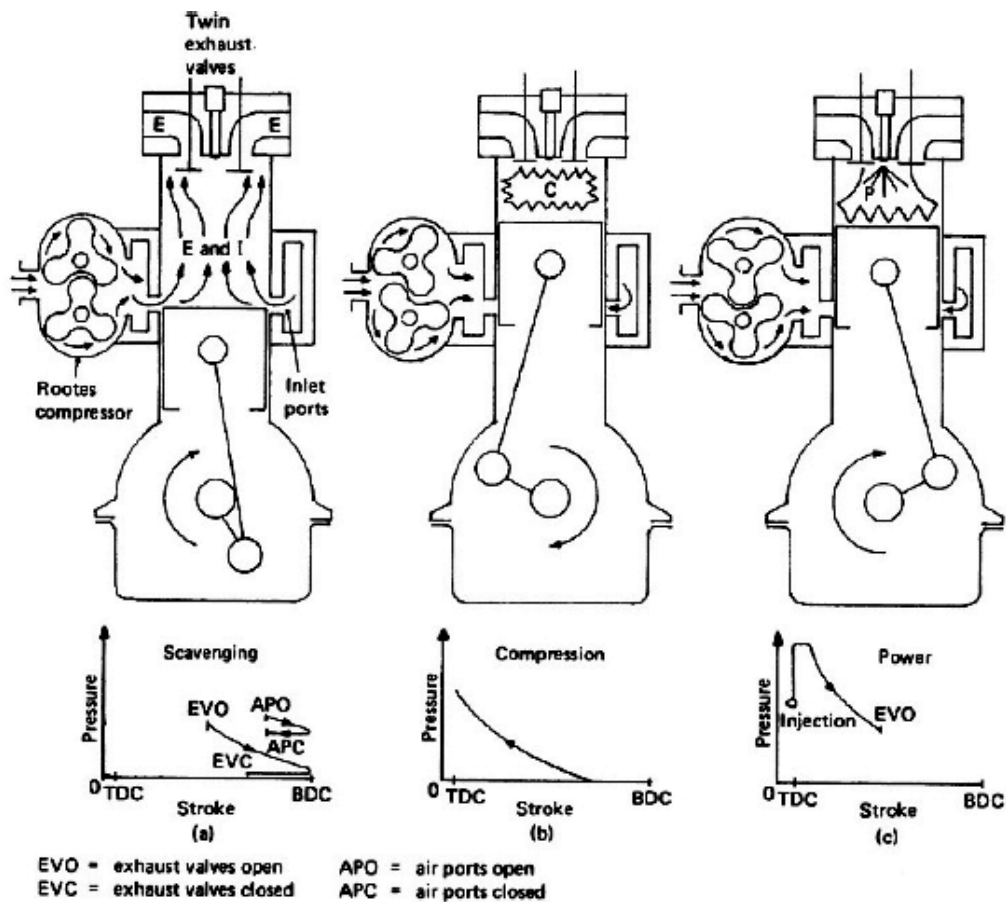

With the two-stroke diesel engine, intake and exhaust phases take place during part of the compression and power stroke respectively, so that a cycle of operation is completed in one crankshaft revolution or two piston strokes. Since there are no separate intake and exhaust strokes, a blower is necessary to pump air into the cylinder for expelling the exhaust gases and to supply the cylinder with fresh air for combustion.

Scavenging (suction and exhaust) phase The piston moves away from the cylinder head and, when it is about half-way down its stroke, the exhaust valves open. This allows the burnt gases to escape into the atmosphere. Near the end of the power stroke, a horizontal row of inlet air ports is uncovered by the piston lands (Fig. 1.1-9(a)). These ports admit pressurized air from the blower into the cylinder. The space above the piston is immediately filled with air, which now blows up the cylinder towards the exhaust valves in the cylinder head. The last remaining exhaust gases will thus be forced out of the cylinder into the exhaust system. This process of fresh air coming into the cylinder and pushing out unwanted burnt gas is known as scavenging.

Compression phase towards the end of the power stroke, the inlet ports will be uncovered. The piston then reaches its outermost position and reverses its direction of motion. The piston now moves upwards so that the piston seals and closes the inlet air ports, and just a little later the exhaust valves close. Any further upward movement will now compress the trapped air. This air charge is now reduced to about 1/15 to 1/18 of its original volume as the piston reaches the innermost position. This change in volume corresponds to a maximum cylinder pressure of about 30-40 bar. Power phase, shortly before the piston reaches the innermost position to the cylinder head on its upward compression stroke, highly pressurized liquid fuel is sprayed into the dense intensely heated air charge. Within a very short period of time, the injected fuel droplets will vaporize and ignite, and rapid burning will be established by the time the piston is at the top of its stroke. The heat liberated from the charge will be converted mainly into gas-pressure energy which will expand the gas and so do useful work in driving the piston outwards.

Comparison of SI and CI Engine

Comparison of S.I. and C.I. engines is made from various aspects is made below:

1. Basic cycle of operation
2. Introduction of fuel
3. Ignition system
4. Compression ratio
5. Speed
6. Thermal efficiency
7. Weight

Fuel economy the chief comparison to be made between the two types of engine is how effectively each engine can convert the liquid fuel into work energy. Different engines are compared by their thermal efficiencies. Thermal efficiency is the ratio of the useful work produced to the total energy supplied. Petrol engines can have thermal efficiencies ranging between 20% and 30%. The corresponding diesel engines generally have improved efficiencies, between 30% and 40%. Both sets of efficiency values are considerably influenced by the chosen compression-ratio and design.

Power and torque the petrol engine is usually designed with a shorter stroke and operates over a much larger crankshaft-speed range than the diesel engine. This enables more power to be developed towards the upper speed range in the petrol engine, which is necessary for high road speeds; however, a long-stroke diesel engine has improved pulling torque over a relatively narrow speed range, this being essential for the haulage of heavy commercial vehicles.

Reliability Due to their particular process of combustion, diesel engines are built sturdier, tend to

run cooler, and have only half the speed range of most petrol engines. These factors make the diesel engine more reliable and considerably extend engine life relative to the petrol engine.

Pollution Diesel engines tend to become noisy and to vibrate on their mountings as the operating load is reduced. The combustion process is quieter in the petrol engine and it runs smoother than the diesel engine. There is no noisy injection equipment used on the petrol engine, unlike that necessary on the diesel engine. The products of combustion coming out of the exhaust system are more noticeable with diesel engines, particularly if any of the injection equipment components are out of tune. It is questionable which are the more harmful: the relatively invisible exhaust gases from the petrol engine, which include nitrogen dioxide, or the visible smoky diesel exhaust gases.

Safety Unlike petrol, diesel fuels are not flammable at normal operating temperature, so they are not a handling hazard and fire risks due to accidents are minimized.

Cost Due to their heavy construction and injection equipment, diesel engines are more expensive than petrol engines.

Valve Timing Diagram

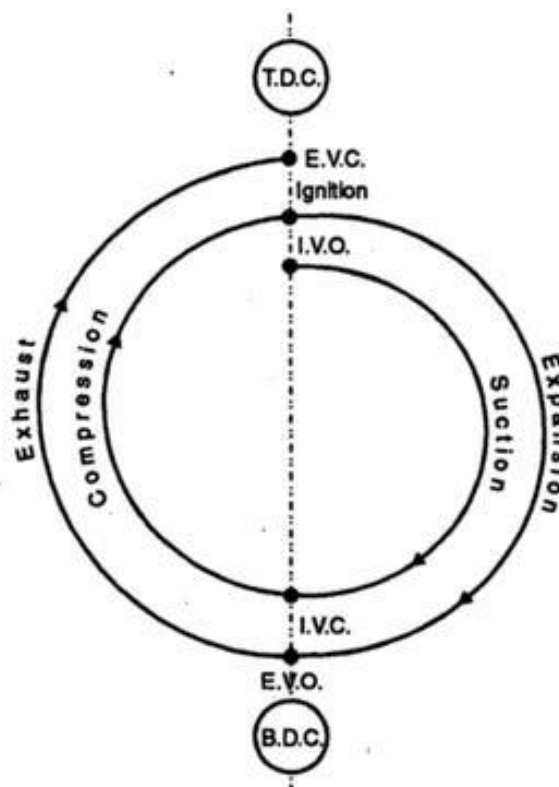

Fig: Theoretical Valve Time Diagram for Otto Cycle

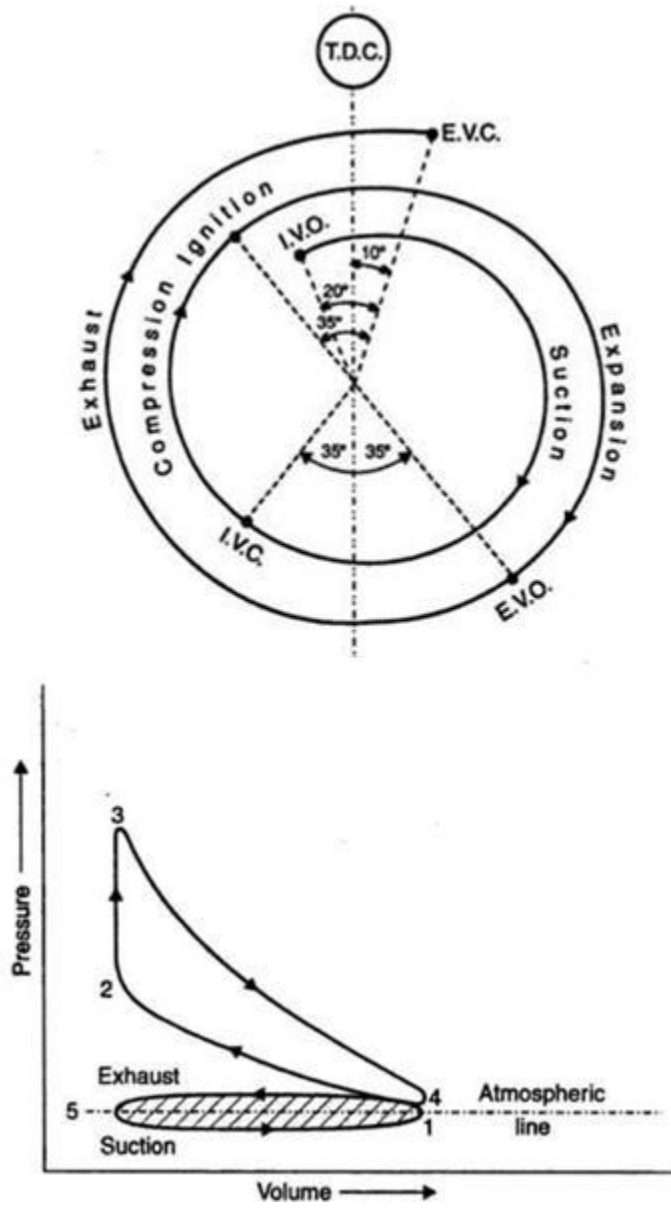

Fig: Actual Valve Time Diagram for Otto Cycle

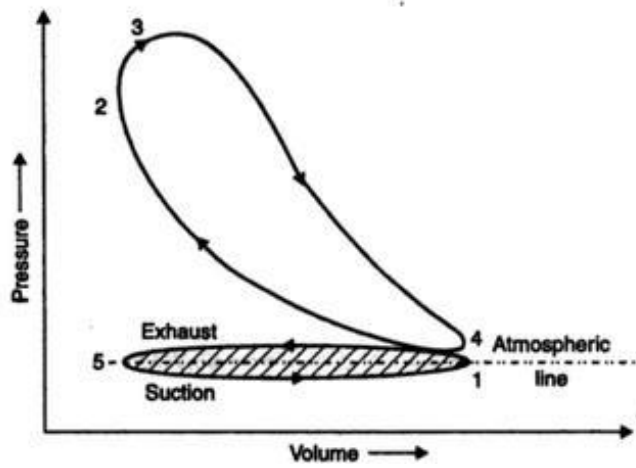
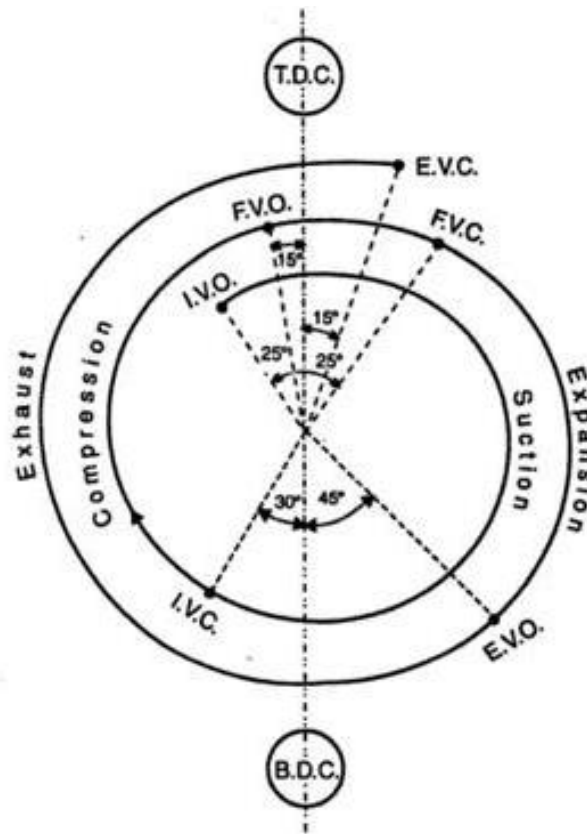

Fig: Actual Valve Time Diagram for Diesel Cycle

1. Ottoengine:

A theoretical valve timing diagram for four-stroke “Otto Cycle” engines which is self-explanatory. In actual practice, it is difficult to open and close the valve instantaneously. So as to get better performance of the engine the valve timings are modified. The inlet valve is opened 10° to 30° in advance of the T.D.C. position to enable the fresh charge to enter the cylinder and to help the burnt gases at the same time, to escape to the atmosphere. The suction of the mixture continues up to $30^\circ - 40^\circ$ (or) even 60° after BDC position. The inlet valve closes and compression of the entrapped mixture starts. The sparking plug produces a spark $30^\circ-40^\circ$ before the TDC position; thus fuel gets more time to burn. The pressure becomes maximum nearly 10° past the TDC position. The exhaust valve opens $30^\circ-60^\circ$ before the BDC position and the gases are driven out of the cylinder by piston during its upward movement. The exhaust valve closes when piston is nearly 10° past TDC position.

2. Dieselenines:

The inlet valve is opened 10° to 25° in advance of the T.D.C. position and closes $25^\circ - 50^\circ$ after BDC position. The exhaust valve opens $30^\circ-50^\circ$ in advance BDC position and closes when piston is nearly 10° to 15° after the TDC position. The fuel injection takes place 5° to 10° before TDC position and continues up to 15° to 25° near TDC position

Port Timing Diagram for Two Stroke PetrolEngine

In two stroke petrol engines, ports are use in its place of valves, and therefore, the port timing diagram.

1. Inlet port

Inlet port opens 35° to 50° prior to TDC position which closes in the same amount after TDC place.

2. Exhaust port

Exhaust port opens and closes 35° near 70° before and after BDC place, in that order.

3. Transfer port

Transfer port opens 35° to 60° in proceed to BDC place and closes 35° to 60° after TDC place.

4. Ignition

Ignition takes place with spark by 15° to 20° before TDC place as charge requires for a while to ignite. It can be noted to the exhaust and transfer ports open and close at the same angles on also side of BDC place.

Port Timing Diagram for Two Stroke Diesel Engine

1. Inlet port

Inlet port opens 35° near 50° prior to TDC position which closes in the same sum after TDC place.

2. Exhaust port

Exhaust port opens and closes 35° to 70° before and after BDC position, correspondingly.

3. Transfer port

Transfer port opens 35° to 60° in move on to BDC position and closes 35° to 60° after TDC place.

4. Ignition

Fuel injection valves opens 10° near 15° before TDC position as air need for a moment to start ignition which closes 15° to 20° after TDC place for improved and capable combustion. The scavenge stage for petrol engines must not go over above 70° where as, this stage is large in case diesel engine.

Port Timing Diagram for Two Stroke C.I Engine

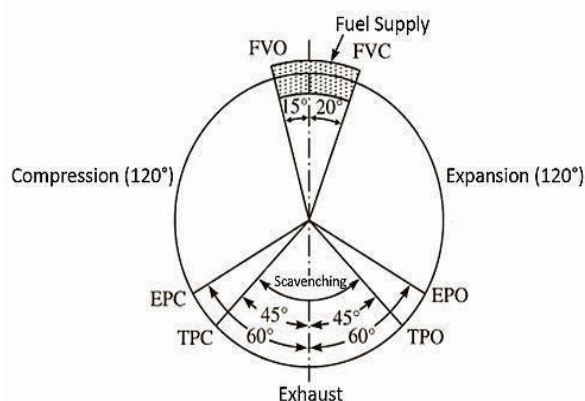

Port Timing Diagram for Two Stroke S.I Engine

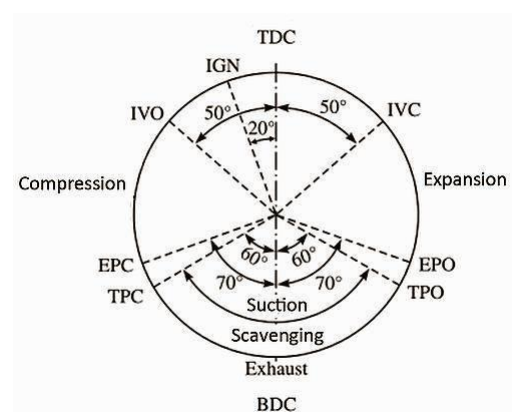

Classification of Internal Combustion Engines

1. Cycle of operation
2. Type of fuel used
 - a. Engine uses volatile liquid fuels like gasoline, alcohol, kerosene, benzene etc.
 - b. Engine using gaseous fuels like natural gas, liquefied petroleum gas, blast furnace gas and biogas
 - c. Engine using solid fuels like charcoal, powdered coal etc.
 - d. Engine using viscous liquid fuels like heavy and light diesel oils
 - e. Engine using dual-fuels
3. Method of charging
 - a. Naturally aspirated engines
 - b. Supercharged engines

4. Type of ignition (a. battery ignition system , b. magneto ignitionsystem)
5. Type of cooling (a. air, b. liquid cooling likewater)
6. CylinderArrangements
 - a. In-line Engine: Auto mobile(4 and 6cylinder)
 - b. "V" Engine: high powered automobiles use the 8 cylinder "V" Engine four in line on each side of:V".
 - c. Opposed Cylinder Engine: This engines has two cylinder banks located in the same plane on opposite sides of the crankshaft. It is well balanced engine and has the advantage of single crankshaft. This design is used in smallaircrafts
 - d. Opposed Piston Engine: It has the advantage of no cylinder head (two stroke Dieselengine)
 - e. Radial Engine: where more than two cylinders in each row are equally spaced around the crankshaft. (air-cooled air craftengines)
 - f. "X" Type Engine: four banks of cylinders attached to a single crankshaft
 - g. "H" Type Engine: Two Opposed Cylinder type utilizing two separate, but interconnected crankshaft.
 - h. Delta Type Engines: combination of three Opposed Piston Engine with three crank shafts interlinked to oneanother.

Application of IC Engines:

Two-stroke Petrol Engine: little high fuel consumption is acceptable. 100-150 CC engine will generate 5 kW at 5500 rpm, 250 CC engine will generate 1 kW at 5000 rpm.

Two-stroke Diesel Engines: ship propulsion (very high power). All engines between 400 to 900 mm bore loop scavenged or uniflow type with exhaust valves, the brake power on single crankshaft can be unto 37000 kW. 12 cylinders, 800 bore and 1550 stroke, develop 20000 kW at 120 rpm. This speed allows the engine to be directly coupled to the propeller ofship.

Four Stroke Petrol Engine: small auto mobiles 4 cylinder 30-60 KW at speed about to 4500 rpm. 6-8 cylinders 185 kW. 4000 CC six cylinder maximum brake power 90 kW. Small pumping sets and mobile electrical generators. Small air crafts having maximum power output from 400 kW to 4000 kW.

Four Stroke Diesel Engines: most efficient and versatile prime mover. Bore 50 mm to 1000 mm and engine speed ranging from 100 to 450 rpm, while developing output up to 35000 kW. Small diesel engines are used in pump sets, construction machinery, air compressors, drilling rigs etc. Tractors, jeeps, buses and trucks use 40 to 100 kW. Locomotive applications require outputs 600 to 4000 kW. Electrical Generation plants

MODULE- II

Combustion in C.I and S.I Engines

Ignition System

The combustion in a spark ignition engine is initiated by an electrical discharge across the electrodes of a spark plug, which usually occurs from 10° to 30° before TDC depending upon the chamber geometry and operating conditions

The ignition system provides a spark of sufficient intensity to ignite the air-fuel mixture at the predetermined position in the engine cycle under all speeds and load conditions. In a four-stroke, four cylinder engine operating at 3000 rpm, individual cylinders require a spark at every second revolution, and this necessitates the frequency of firing to be $(3000/2) \times 4 = 6000$ sparks per minute or 100 sparks per second. This shows that there is an extremely short interval of time between firing impulses.

Ignition System –Requirements

- It should provide a good spark between the electrodes of the plugs at the correct timing
- The duration of the spark must be long enough with sufficient energy to ensure that ignition of the mixture has a high chance of occurring
- The system must distribute this high voltage to each of the spark plugs at the exact time in every cycle, i.e., it must have in it a distributing device
- It should function efficiently over the entire range of engine speed
- It should be light, effective and reliable in service

Glow plug ignition

One of the early ignition systems employed was the glow plug ignition used in some kinds of simple engines like model aircraft

A glow plug is a coil of nickel chrome wire that will glow red hot when an electric current is passed through it. This ignites the air-fuel mixture upon contact.

The coil is electrically activated from engine starting, and once it runs, it will retain sufficient residual heat on each stroke due to heat generated on the previous stroke.

Glow plugs are also used to aid starting of diesel engines.

Contact ignition

The other method used was the contact ignition. It consisted of a copper or brass rod that project into the cylinder, and was heated using an external source. Heat conduction kept the end of the rod hot, and ignition takes place when the combustible mixture comes into its contact. Naturally this was very inefficient as the fuel would not be ignited in a controlled manner.

This type of arrangement was quickly superseded by spark ignition

Modern ignition systems

The development of high speed, high compression internal combustion engine requires a

reliable high-speed ignition system. This is met by a high-tension ignition system that uses a spark plug as the source of ignition. The electrical energy to the spark plug is supplied by one of the following systems and is termed accordingly

1. Battery ignition system
2. Magneto ignition system
3. Electronic ignition system

Battery ignition system

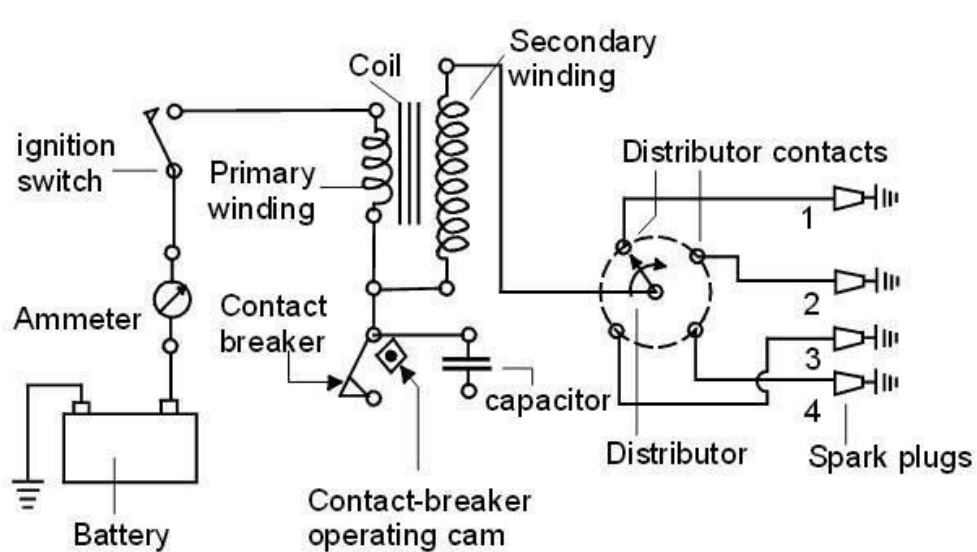

- The primary circuit consists of the battery, ammeter, ignition switch, primary coil winding, capacitor, and breaker points. The functions of these components are:
- Battery: provides the power to run the system
- Ignition switch: allows the driver to turn the system on and off
- Primary coil: produces the magnetic field to create the high voltage in the secondary coil
- Breaker points: a mechanical switch that acts as the triggering mechanism
- Capacitor: protects the points from burning out

The secondary circuit converts magnetic induction into high voltage electricity to jump across the spark plug gap, firing the mixture at the right time. The functions of the components are:

- Secondary coil : the part of the coil that creates the high voltage electricity
- Coil wire : a highly insulated wire to take the high voltage to the distributor cap
- Distributor cap : a plastic cap which goes on top of the distributor, to hold the high tension wires in the right order
- Rotor : spins around on the top of the distributor shaft, and distributes the spark to the right spark plug
- Spark plug leads : another highly insulated wire that takes the high voltage from the cap to the plugs

- Spark plugs: take the electricity from the wires, and give it an air gap in the combustion chamber to jump across, to light the mixture

The current flowing through the primary coil, which is wound on a soft iron core, produces magnetic field in the core. A cam driven by the engine shaft is arranged to open the breaker points whenever an ignition discharge is required. When the breaker point open, the current which had been flowing through the points now flows into the condenser, which is connected across the points. As the condenser becomes charged the primary current falls and magnetic field collapses. The collapse of this field induces a voltage in the primary winding, which charges the condenser to a voltage much higher than the battery voltage. The condenser then discharges into the battery, reversing the direction of both the primary current and the magnetic field. The rapid collapse and reversal of the magnetic field in the core induce a very high voltage in the secondary winding of the ignition coil. The secondary winding consists of a large number of turns of very fine wire wound on the same core with the primary. The high secondary voltage is led to a proper spark plug by means of rotating switch called the distributor, which is located in the secondary or high tension circuit of the ignition system.

Magneto ignition system

- The high powered, high speed spark ignition engines like aircraft, sports and racing cars use magneto ignition system.
- The basic components of a magneto ignition system consist of a magneto, breaker points, capacitor, ignition switch, distributor, spark plug leads, and spark plugs.
- Magneto can either be rotating armature type or rotating magneto type. In the former, the armature consisting of the primary and secondary windings all rotate between the poles of a stationary magneto, while in the second type, the magneto revolves and the windings are kept stationary.

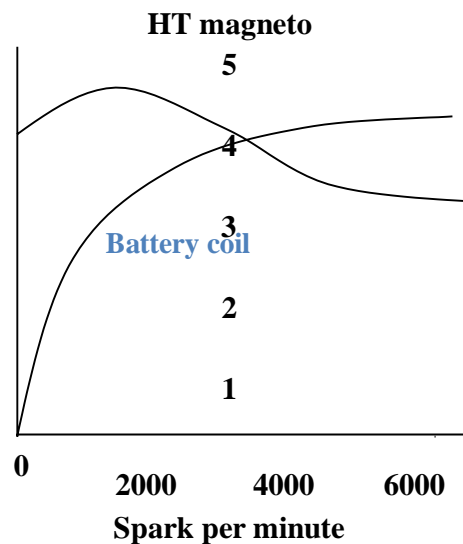

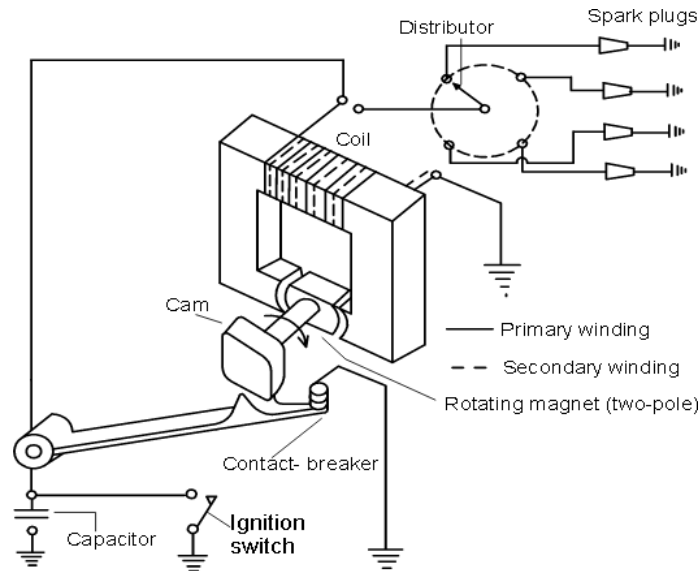

A magneto when rotated by the engine is capable of producing a very high voltage and does not need a battery as a source of external energy. The high tension magneto incorporates the windings to generate the primary voltage as well as to step up the voltage and thus does not require a separate coil to boost up the voltage required to operate the spark plug. Magnet revolves and winding kept stationary.

The variation of the breaker current with speed for the coil ignition system and magneto ignition system in below fig. It can be seen that since the cranking speed at start is low the current generated by the magneto is quite small. As the engine speed increases the flow of current also increases.

Comparison between Battery Ignition and Magneto Ignition System.

Battery Ignition System	Magneto Ignition System
Battery is necessary, Difficult to start the engine when battery is discharged	No battery is needed and therefore there is no problem of battery discharge.
Maintenance problems are more due to battery	Maintenance problems are less since there is no battery
Current from the primary circuit is obtained from the battery	The required electrical current is generated by the magneto
A good spark is available at the spark plug even at low speed	During starting quality of spark is poor due to low speed
Efficiency of the system decreases with reduction in spark intensity as engine speed rises.	Efficiency of the system improves as the engine speed rises due to high intensity spark.
Occupies more space	Occupies less space
Commonly employed in cars and light commercial vehicles.	Mainly used in racing cars and two wheelers

Firing Order

Firing order indicates the sequence or order in which the firing impulses occur in a multi-cylinder spark ignition engine. It is chosen to give a uniform torque, and hence a uniform distribution of firing per revolution of the engine.

This is naturally dictated by the engine design, the cylinder arrangement and the crankshaft design. The firing order be such that there must always be a proper balance so as to minimize the engine vibration.

As for example, in a four-stroke, four-cylinder engine, the firing or the ignition in all the cylinders has to be completed in two revolutions of the crankshaft. With crank throws at 180° , the cylinders 1 and 4 will reach TDC at the same time. Now, if the firing interval is made by 180° , the firing in cylinder-1 cannot be followed by cylinder-4.

For the same reason, the firing of cylinder-2 cannot be followed by cylinder-3. As such, the possible sequence is 1-2-4-3 or 1-3-4-2.

Consider another example of four-stroke, six-cylinder inline engine, where cranks are set at 120° , and with the cylinders 1-6, 2-5 and 3-4 will reach TDC simultaneously. Here, the possible sequence is 1-5-3-6-2-4 or 1-4-2-6-3-5.

For radial engines, the cylinders are usually numbered consecutively. Thus, for a seven-cylinder radial engine, the sequence is 1,3,5,7,2,4,6.

Carburetion

The process of mixture preparation in an SI engine is called carburetion. This air-fuel mixture is prepared outside the cylinder in a device called CARBURETOR.

The carburetor atomizes the fuel and mixes with air in different proportions for various LOAD conditions

Functions

It must atomize, vaporize and mix the fuel homogeneously with air.

It must supply correct amount of air-fuel mixture in correct proportion under all load conditions and speed of the engine.

It must run the engine smoothly by supplying correct mixture strength

Chemically correct (15:1)

Rich Mixture (9:1)

Lean Mixture (19:1)

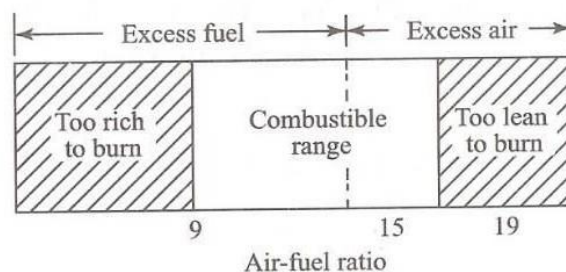

Variation of power output and SFC with A-F ratio in SI engine (Full throttle and constant speed)

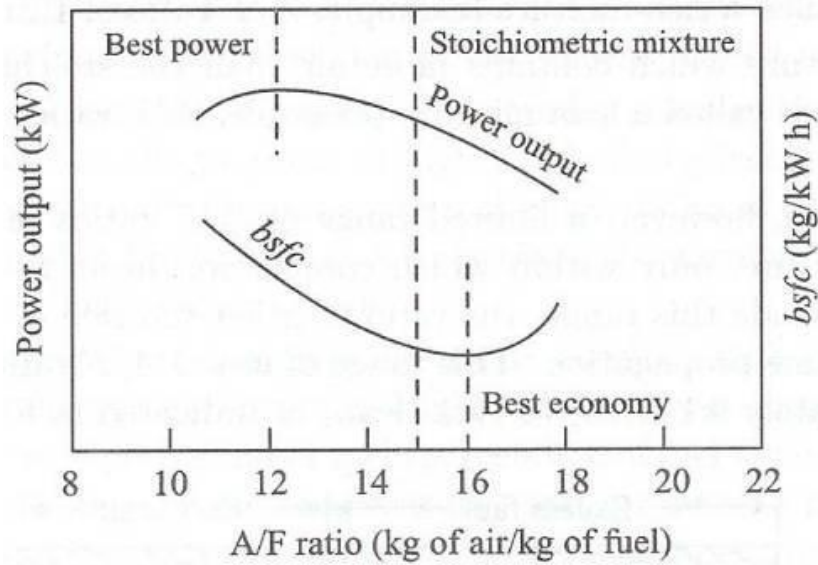

Output=12:1 (Best power mixture)

Minimum Fuel Consumption = 16:1 (Best economy mixture)

Various Loads

Idling/Starting: Engine runs without load. Produces power only to overcome friction between the parts. Rich mixture is required to sustain combustion.

Normal Power/Cruising/Medium Load: Engine runs for most of the period. Therefore, fuel economy is maintained. Low fuel consumption for maximum economy. Requires a lean mixture.

Maximum power/Acceleration: Overtaking a vehicle (short period) or climbing up a hill (extra load). Requires a rich mixture

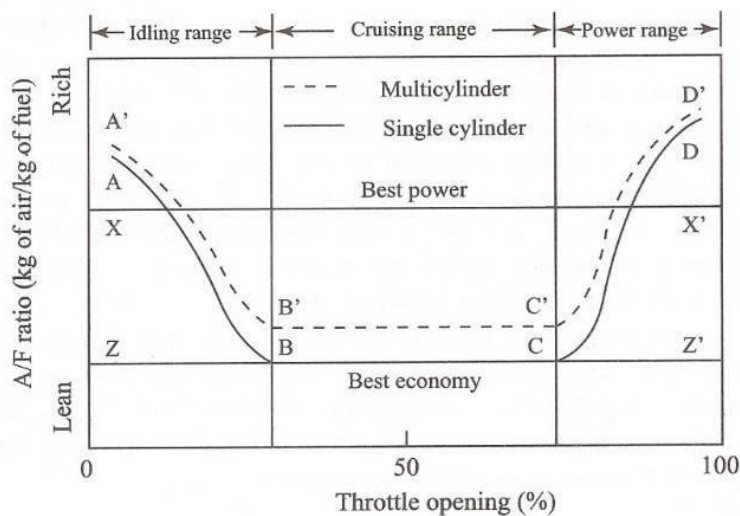

Simple Carburetor Operation

Because of the narrow passage at the venturi throat, the air velocity increases but its pressure falls. This causes a partial vacuum (called carburetor depression) at the venturi throat. This carburetor depression causes fuel to come out as jet in the form of a spray. This fuel spray vaporizes and mixes with the incoming air, and the mixture goes into the cylinder through the throttle valve

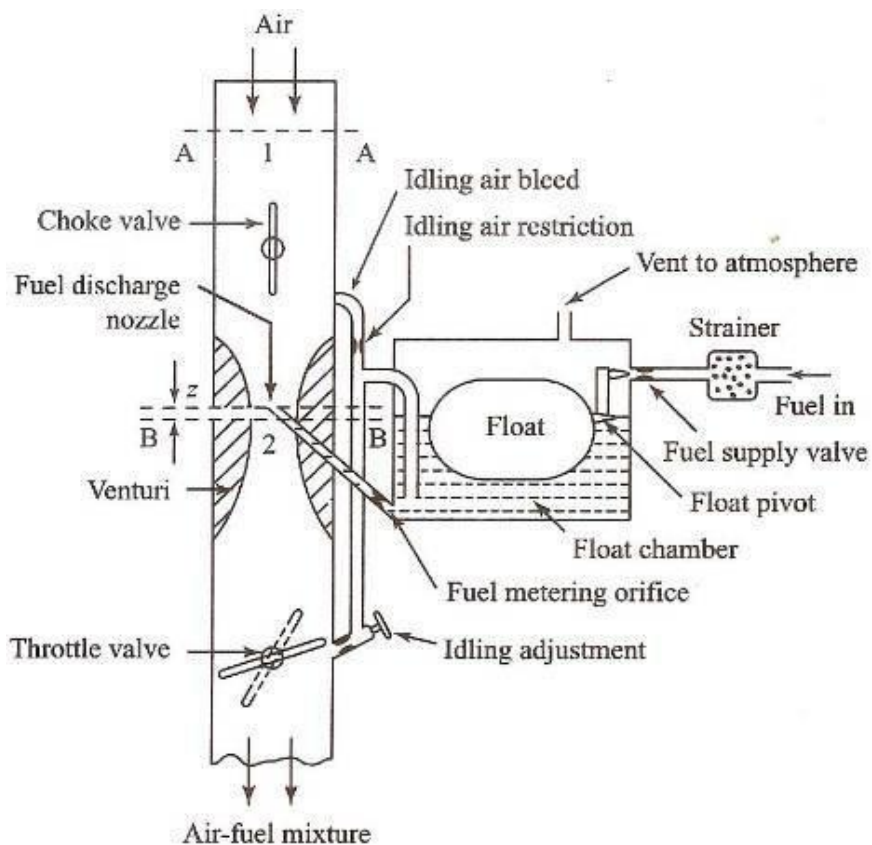
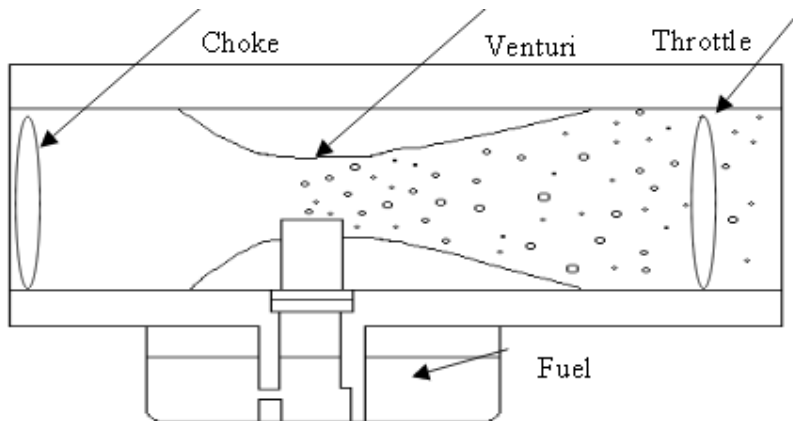

Essential parts of a carburetor

1. Fuel Strainer

To prevent possible blockage of the nozzle by dust particles, the fuel is filtered by installing a fuel strainer at the inlet to the float chamber.

2. The Float Chamber

The function of a float chamber in a carburetor is to supply the fuel to the nozzle at constant pressure head. This is possible by maintaining a constant level of the fuel in the float bowl. The fuel level must be maintained slightly below the discharge nozzle outlet holes in order to prevent leakage of the fuel from the nozzle when the engine is not operating.

3. The Choke and The Throttle

At low cranking speeds and initial temperatures a very rich mixture (9:1) is required. The most popular method of providing such mixture is by using of choke valve. This is simple butterfly valve located between the entrance to the carburetor and venturi throat. When the choke is partly closed, large pressure drop occurs at the venturi throat results large amount of fuel from the main nozzle and provides rich mixture.

The speed and the output of an engine is controlled by the use of the throttle valve, which is located on the downstream side of the venturi. It is simply a means to regulate the output of the engine by varying the quantity of charge going into the cylinder.

4. The Main Metering and Idling System.

The main metering system of the carburetor controls the fuel feed for cruising and full throttle operation. It consists of three principal units.

- i. The fuel metering orifice through which fuel is drawn from the float chamber.
- ii. The main discharge nozzle
- iii. The passage leading to the idling system.

Complete Carburetor

A simple carburetor is capable to supply a correct air-fuel mixture to the engine only at a particular load and speed. In order to meet the engine demand at various operating conditions, the following additional systems are added to the simple carburetor.

- Idling system
- Auxiliary port system
- Power enrichment by economizer system
- Accelerating pump system
- Choke

• Idling system:

During starting or idling, engine runs without load and the throttle valve remains in closed position. Engine produces power only to overcome friction between the parts, and a rich mixture is to be fed to the engine to sustain combustion.

The idling system as shown consists of an idling fuel passage and an idling port. When the throttle is partially closed, a depression past the throttle allows the fuel to go into the intake through the idle tube. The depression also draws air through the idle air bleed and mixes with fuel. The fuel flow depends on the location of the idle nozzle and the adjustment of the idle screw.

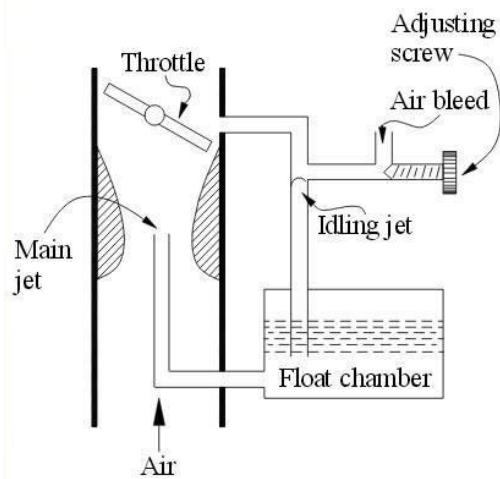

- **Auxiliary portsystem**

During normal power or cruising operation, where the engine runs for most of the period, the fuel economy has to be maintained. Thus, it is necessary to have lower fuel consumption for maximum economy. One such arrangement used is the auxiliary port carburetor as shown, where opening of butterfly valve allows additional air to be admitted, and at the same time depression at the venturi throat gets reduced, thereby decreasing the fuel flowrate.

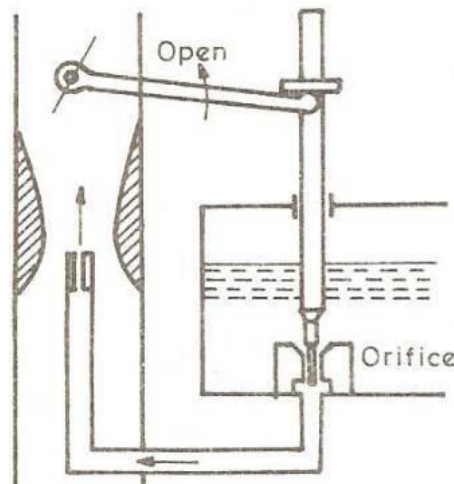

- **Power enrichment by economizersystem**

In order to obtain maximum power, the carburetor must supply a rich mixture. This additional fuel required is supplied by a power enrichment system that contains a meter rod economizer that provides a larger orifice opening to the main jet as the throttle is opened beyond a certain point.

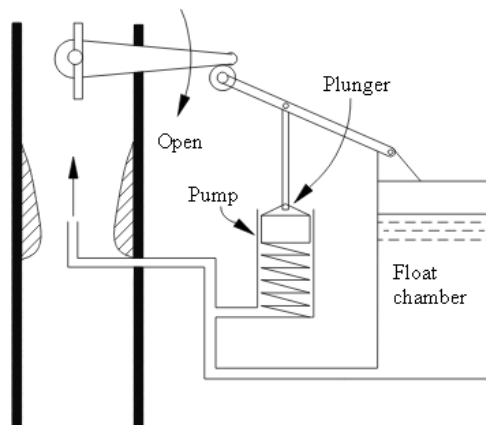

- **Accelerating pump system**

During sudden acceleration of an engine (e.g., overtaking a vehicle), an extra amount of fuel is momentarily required to supply a rich mixture. This is obtained by an accelerating pump system. It consists of a spring-loaded plunger, and the necessary linkage mechanism. The rapid opening of the throttle moves the plunger into the cylinder, and an additional amount of fuel is forced into the venturi.

Types of Carburetor based on direction of flow

- Up-draught (updraft) carburetor
- Down-draught (downdraft) carburetor
- Cross-draught or horizontal carburetor

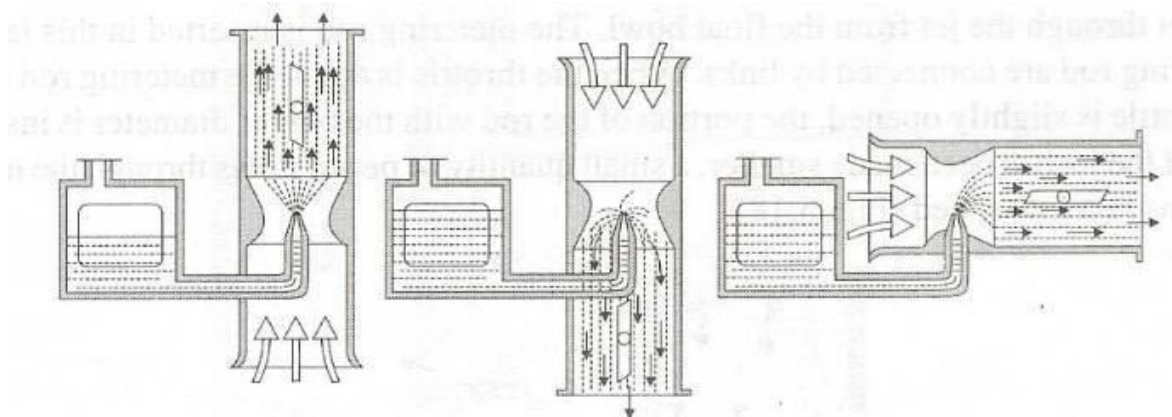

Important Carburetor requirement of Automobile Engine:

1. Ease of starting the engine, particularly under low ambient conditions.
2. Ability to give full power quickly after starting the engine.
3. Equally good and smooth engine operation at various loads
4. Good and quick acceleration of the engine.
5. Developing sufficient power at high engine speeds
6. Simple and compact in construction
7. Good fuel economy
8. Absence of racing of the engine under idling conditions
9. Ensuring full torque at low speeds.

Some of the popular brands of carburetors in use are (i) Solex (ii) Carter (iii) S.U carburetor.

Injection System

Initiating and controlling the combustion process. Fuel Injection System –Requirements

- The fuel injection should occur at the correct moment
- It should supply the fuel in correct quantity as required by the varying engine loads
- The injected fuel must be broken into very fine droplets
- The spray pattern should ensure rapid mixing of fuel and air
- It should supply equal quantities of metered fuel to all the cylinders in a multi cylinder engines
- The beginning and the end of injection should be sharp

Types of Injection Systems Air (Blast) Injection System:

In air blast injection system, fuel is forced into the cylinder by means of compressed air. This system is little used universally at present, because it requires a multistage air compressor, which increases engine weight and reduces brake power.

This method is capable of producing better mixing of fuel resulting in higher brake mean effective pressure. Another is the ability to utilize fuels of high viscosity which are less expensive.

Solid Injection System:

In solid injection, the liquid fuel is injected directly into the combustion chamber without the aid of compressed air. Hence, it is termed as airless mechanical injection or solid injection.

Every solid injection system must have a pressuring unit (the pump) and an atomizing unit (the injector).

Solid Injection –Classification

Depending upon the location of the pumps and injectors, and the manner of their operations, solid injection systems may be further classified as follows:

- Common Rail System
- Unit Injection System
- Individual Pump and Nozzle System
- Distributor System

Elements of Fuel Injection System

- Distribution elements: to divide the metered fuel equally among the cylinders
- Pumping elements: to supply fuel from fuel tank to cylinder
- Metering elements: to meter fuel supply as per load and speed
- Timing controls: to adjust the start and the stop of injection
- Mixing elements: to atomize and distribute the fuel within the combustion chamber Fuel from the fuel tank first enters the coarse filter from which is drawn into the plunger feed pump where the pressure is raised very slightly. Then the fuel enters the fine filter where all the dust and dirt particles are removed. From the fine filter the fuel enters the fuel pump where it is pressurized to about 200 bar and injected into the engine cylinder by means of the injector. Any spill over in the injector is returned to the fine filter. A pressure relief valve is also provided for safety of the system.

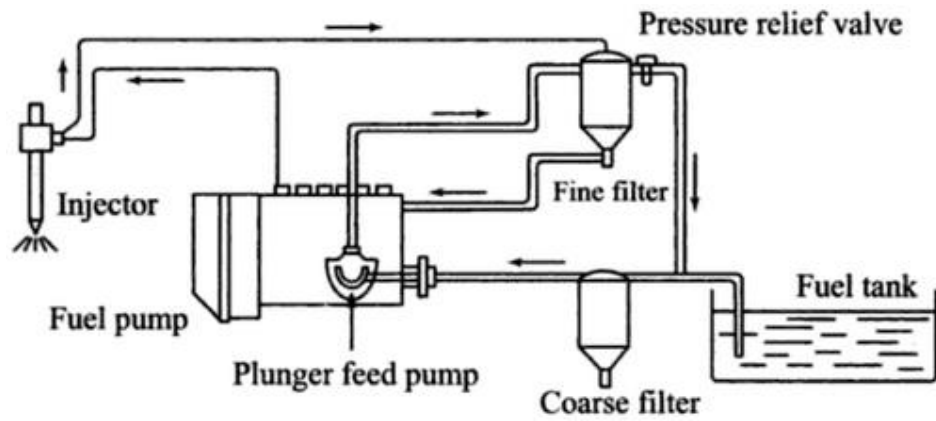

Common Rail System

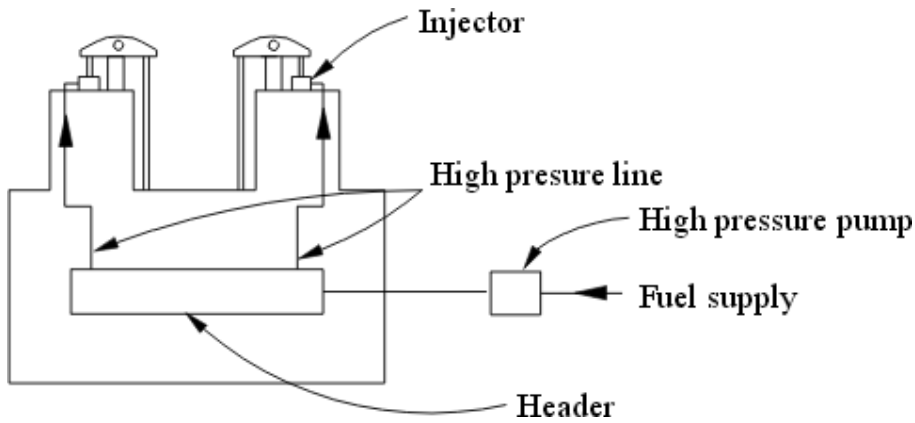

In this system, a high-pressure pump supplies fuel to a fuel header as shown. The high- pressure in the header forces the fuel to each of the nozzles located in the cylinders. At the proper time, a mechanically operated (by means of push rod and rocker arm) valve allows the fuel to enter the cylinder through nozzle.

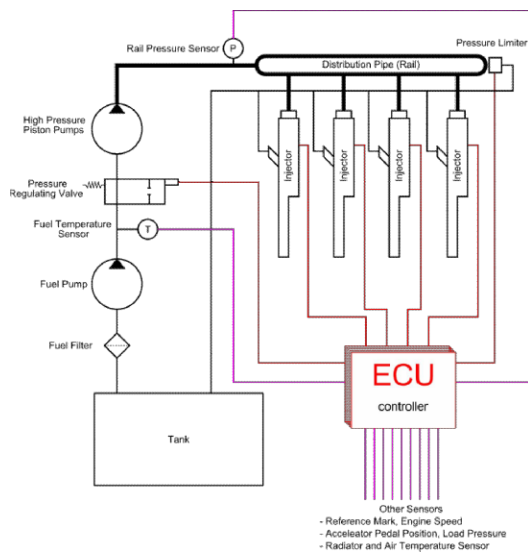

In common rail systems, a high-pressure pump stores a reservoir of fuel at high pressure — up to and above 2,000 bars (200 MPa; 29,000 psi). The term "common rail" refers to the fact that all of the fuel injectors are supplied by a common fuel rail which is nothing more than a pressure accumulator where the fuel is stored at high pressure. This accumulator supplies multiple fuel injectors with high-pressure fuel. This simplifies the purpose of the high-pressure pump in that it only needs to maintain a commanded pressure at a target (either mechanically or electronically controlled). The fuel injectors are typically ECU-controlled. When the fuel injectors are electrically activated, a hydraulic valve (consisting of a nozzle and plunger) is mechanically or hydraulically opened and fuel is sprayed into the cylinders at the desired pressure. Since the fuel pressure energy is stored remotely and the injectors are electrically actuated, the injection pressure at the start and end of injection is very near the pressure in the accumulator (rail), thus producing a square injection rate. If the accumulator, pump and plumbing are sized properly, the injection pressure and rate will be the same for each of the multiple injection events.

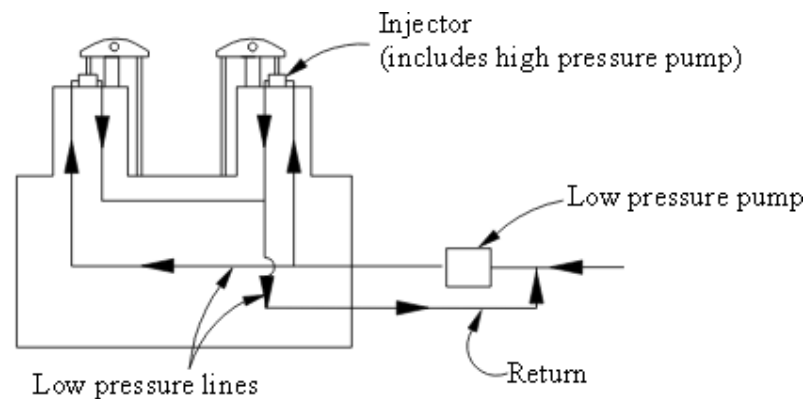

(b)

Unit Injection System

Here, the pump and nozzle are combined in one housing. Each cylinder is provided with one of these unit injectors. Fuel is brought up to the injector by a low-pressure pump, where at the proper time; a rocker arm activates the plunger and thus injects the fuel into the cylinder.

The quantity of fuel injected is controlled by the effective stroke of the plunger.

Individual Pump and Nozzle Systems

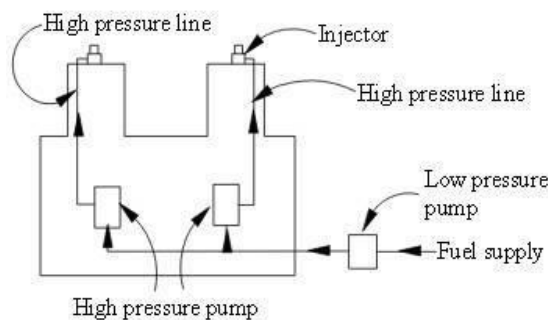

Separate pumps

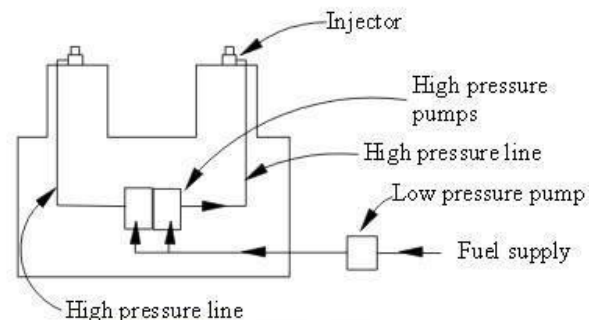

Pumps in Clusters

In this system, each cylinder is provided with one pump and one injector. This type differs from the unit injector in that the pump and injector are separated from each other, i.e., the injector is located on the cylinder, while the pump is placed on the side of the engine. Each pump may be placed close to the cylinder, or may be arranged in a cluster. The high-pressure pump plunger is actuated by a cam, and produces the fuel pressure necessary to open the injector valve at the correct time. The quantity of fuel injected is again controlled by the effective stroke of the plunger.

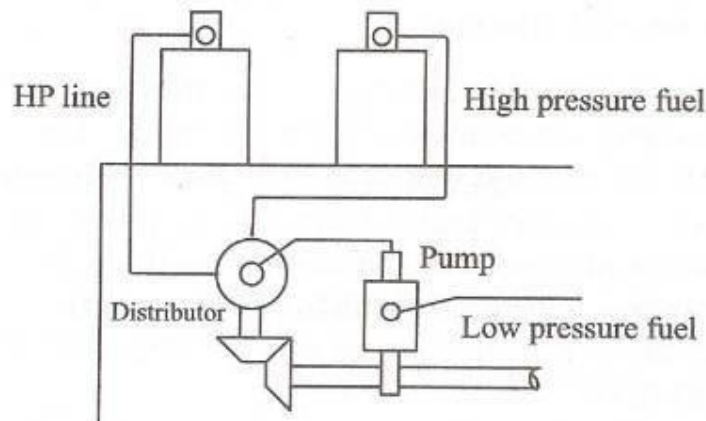

Distributor System

Here, the pump which pressurizes the fuel also meters and times it. The fuel pump after metering the required quantity of fuel supplies it to a rotating distributor at the correct time for supply to each cylinder. Since there is one metering element in each pump, a uniform distribution is ensured.

Two common types include the unit injection system and the distributor/inline pump systems. While these older systems provided accurate fuel quantity and injection timing control, they were limited by several factors:

- They were cam driven, and injection pressure was proportional to engine speed. This typically meant that the highest injection pressure could only be achieved at the highest engine speed and the maximum achievable injection pressure decreased as engine speed decreased. This relationship is true with all pumps, even those used on common rail systems. With unit or distributor systems, the injection pressure is tied to the instantaneous pressure of a single pumping event with no accumulator, and thus the relationship is more prominent and troublesome.
- They were limited in the number and timing of injection events that could be commanded during a single combustion event. While multiple injection events are possible with these older systems, it is much more difficult and costly to achieve.
- For the typical distributor/inline system, the start of injection occurred at a pre-determined pressure (often referred to as: pop pressure) and ended at a pre-determined pressure. This characteristic resulted from "dumb" injectors in the cylinder head which opened and closed at

pressures determined by the spring preload applied to the plunger in the injector. Once the pressure in the injector reached a pre-determined level, the plunger would lift and injection would start.

Injection Pump and Governor

The main objective of the fuel injection pump is to deliver accurately a metered quantity of fuel under high pressure at the correct instant to the injector fitted on each cylinder. Two types of pumps are generally used viz., jerk type and distributor type.

Fuel delivered by a pump increases with speed while the opposite is true about the air intake. This results in over fueling at higher speeds. At low speeds, the engine tends to stall due to insufficiency of fuel. To overcome this, injector pump governors are generally used.

Two types of governors are found in applications viz., (a) mechanical governor and (b) pneumatic governor.

Fuel Injectors and Nozzles

Quick and complete combustion is ensured by a well-designed fuel injector. By atomizing the fuel into very fine droplets, it increases the surface area of the droplets resulting in better mixing and subsequent combustion. Atomization is done by forcing the fuel through a small orifice under high pressure. An injector assembly consists of the following components.

- a needle valve
- a compression spring
- a nozzle
- an injector body

Components of injector nozzle

Operation

- Fuel is injected by a pump. The pump exerts sufficient pressure/force that lifts the nozzle valve.
- When the nozzle valve is lifted up, fuel is sprayed into the combustion chamber. As the fuel supply is exhausted, the spring pushes the valve back on its seat.
- The spring tension and hence the valve operating pressure is controlled by adjusting the screw at the top.

Nozzle

The nozzle sprays the liquid fuel. The functions of the nozzle are: (a) atomization, (b) distribution of fuel to the required area, (c) non-impingement on the walls, and (d) no leakage. Note:

- High injection pressure allows better dispersion and penetration into the combustion chamber. High air density in the cylinder gives high resistance to the droplets. This further causes dispersion.
- The fuel striking on the walls decomposes and produces carbon deposits. This causes smoky exhaust and increases fuel consumption.

Lubrication

The lubrication is essential to reduce friction and wear between the components in an engine.

Function of lubrication: It is an art of admitting a lubricant, between two surfaces that are in contact and in relative motion. The purpose of lubrication in an engine is to perform the following functions

- a. To reduce friction and wear between the moving parts and thereby the engine loss and increase the life of the engine.
- b. To provide sealing action eg. The lubricating oil helps the piston rings to maintain an effective seal against the high pressure gases in the cylinder from the leaking out into the crankcase.
- c. To cool the surface by carrying away the heat generated in engine components.
- d. To clean the surfaces by washing away carbon and metal particles caused by wear.
 - i. Friction between the components and metal to metal contact
 - ii. Overheating of the components
 - iii. Wear of the components
 - iv. Corrosion
 - v. Deposits

Lubrication Engine Components

- i. **Piston and cylinders**
- ii. **Crankshaft and their bearing**
- iii. **Crankpin and their bearing**
- iv. **Wristpin and their bearing**
- v. **Valve gear Properties of lubrication**

1. **Viscosity:** high load high viscosity and high speed low viscosity
Viscosity Index: it is a measure of change in viscosity of an oil with temperature as compared to the reference oils having the same viscosity at 100 °C. where in a typical Pennsylvania (paraffinic base) oil is assigned an index of 100 and gulf coast (naphthenic – base) oil is assigned an index of 0.
2. **Flash and fire points:** high flash point and fire point
3. **Cloud and pour points:** wax separation and stop flowing
4. **Oiliness or film strength:** it refers to the ability of lubricant to resist welding.
5. **Corrosiveness:** no
6. **Detergency:** dispersing properties
7. **Stability:** the ability of oil to resist oxidation that would yield acids.
8. **Foaming:** it describes the condition where minute bubbles of air are held in the oil.

Additives for lubricants

1. **Anti-oxidants and anticorrosive agents:** Zinc dithiophosphate
2. **Detergent-dispersant:** metallic salts or organic acids
3. **Extreme pressure additives:**
4. **Pour point depressors:** add wax containing oils to lower the pour point instead of de-waxing the oil.
5. **Viscosity index improvers:** high molecule polymers
6. **Oiliness and film strength agents:** organic sulphur, chlorine and phosphorus compounds.
7. **Antifoam agents:** silicone polymers

Lubrication systems: The function of a lubrication system is to provide sufficient quantity of cool, filtered oil to give positive and adequate lubrication to all the moving parts of an engine.

1. Mist lubrication system

This system is used where crankcase lubrication is not suitable. In two stroke engine, as the charge is compressed in the crankcase, it is not possible to have the lubricating oil sump. Hence, mist lubrication is adopted in practice. In such engines, the lubricating oil is mixed with the fuel, the usual ratio being 3% to 6%. The oil and fuel mixture is inducted through the carburetor. The fuel is vaporized and the oil in the form of mist goes via the crankcase into cylinder. The oil which strikes the crankcase walls lubricates the main and connecting rod bearing, and the rest of oil lubricates the piston, piston rings and cylinder.

The advantage of this system is its simplicity and low cost as it does not require an oil pump, filter, etc. However, there are certain disadvantages which are enumerated below.

- i. It causes heavy exhaust smoke due to burning of lubricating oil partially or fully and also forms deposits on piston crown and exhaust ports which affect engine efficiency.
- ii. Since the oil comes in close contact with acidic vapours produced during the combustion process gets contaminated and may result in the corrosion of bearing surface.
- iii. This system calls for a thorough mixing for effective lubrication. This requires either separate mixing prior to use or use of some additive to give the oil good mixing characteristics.
- iv. During closed throttle operation as in the case of the vehicle moving down to hill, the engine will suffer from insufficient lubrication as the supply of fuel is less.

In some of the modern engines, the lubricating oil is directly injected into the carburetor and the quantity of oil is regulated. Thus the problem of oil deficiency is eliminated to a very great extent. In this system the main bearing also receive oil from a separate pump. For this purpose, they will be located outside the crankcase. With system, formation of deposits and corrosion of bearings are also eliminated.

2. Wet sump lubrication system

In this wet sump system, the bottom of the crankcase contains an oil pan or sump from which the lubricating oil is pumped to various engine components by a pump. After lubricating these parts, the oil flows back to the sump by gravity. Again it is picked up by pump and re-circulated through the engine lubricating system. There are three varieties in the wet sump lubrication system.

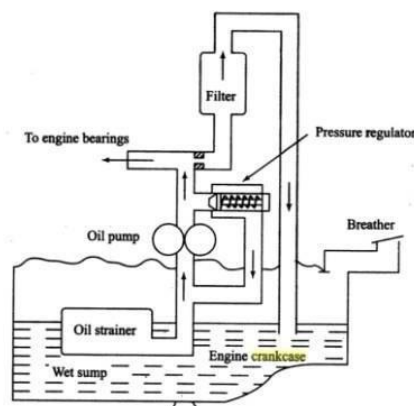

Basic components of Wet Sump Lubrication System

A. The splash system

This system is used in light duty engines. The lubricating oil is charged into the bottom of the engine crankcase and maintained at a predetermined level. The oil is drawn by pump and delivered through a distributing pipe extending the length of the crankcase into splash troughs located under the big end of all the connecting rods. These troughs were provided with overflows and the oil in the troughs are kept at constant level. A splasher or dipper is provided under each connecting rod cap which dips into the oil is splashed all over the interior of the crankcase, into the piston and on to the exposed portion of the cylinder walls. A hole is drilled through the connecting rod cap through which oil will pass to the bearing surface. Oil pockets are also provided to catch the splashing oil over all the main bearings and also over the camshaft bearings. The oil dripping from the cylinders is collected in the sump where it is cooled by air flowing around. The cooled oil is then recirculated.

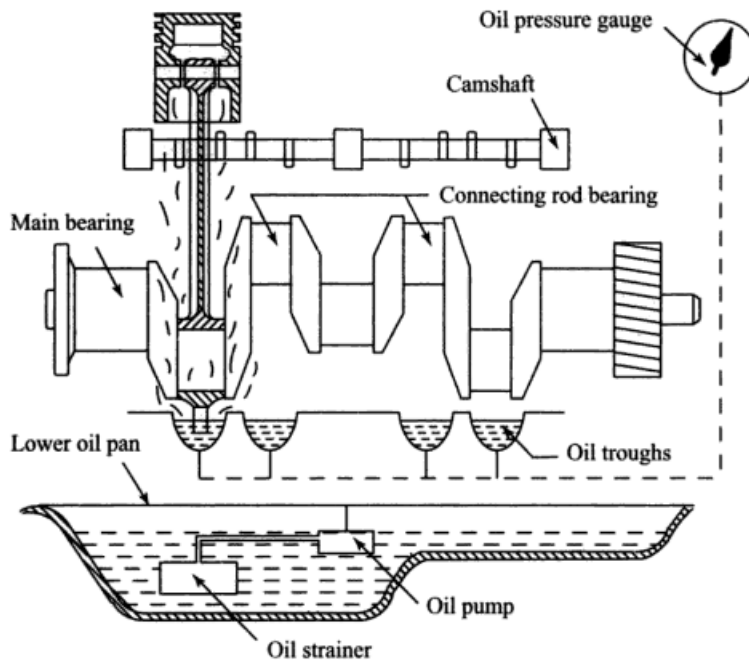

B. The splash and pressure system

Lubricating oil is supplied under pressure to main and camshaft bearings. Oil is also supplied under pressure to pipes which direct a stream of oil against the dippers on the big end of the connecting rod bearing cup and thus the crankpin bearings are lubricated by the splash or spray of oil throw up by the dipper.

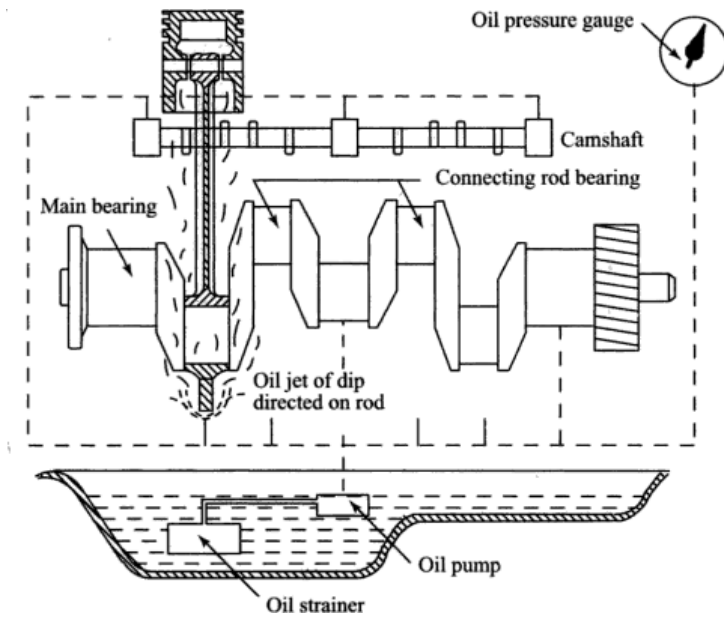

C. The pressure feedsystem.

Oil is drawn in from the sump and forced to all the main bearings of the crankshaft through distributing channels. A pressure relief valve will also be fitted near the delivery point of the pump which opens when the pressure in the system attains a predetermined value. An oil hole is drilled in the crankshaft from the centre of each crankpin to the centre of an adjacent main journal, through which oil can pass from the main bearings to the crankpin bearing. From the crank pin it reaches piston pin bearing through a hole drilled in the connecting rod. The cylinder walls, piston and piston rings are lubricated by oil spray from around the piston pins and themain connected rod bearings. 1. Pump ii. Strainer iii. Pressure regulator iv. Filter v. breather. Oil is drawn from the sump by gear or rotor type oil pump through an oil strainer. The strainer is a fine mesh screen which prevents foreign particles from the entering the oil circulating systems. A pressure relief valve is provided which automatically keeps the delivery pressure constant and can be set to any value. Most of the oil from the pump goes directly to the engine bearings and a portion of the oil passes through a cartridge filter which removes the solid partials from the oil. This reduces the amount of contamination from carbon dust and other impurities present in theoil.

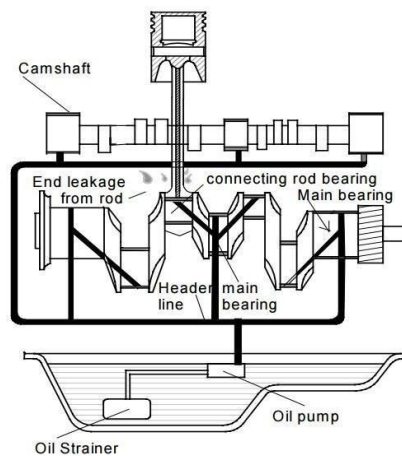

3. Dry sump lubrication

In this the supply of oil is carried in an external tank. An oil pump draws oil from the supply tank and circulates it under pressure to various bearings of the engine. Oil dripping from the cylinders and bearings into the sump is removed by a scavenging pump which internally the oil is passed through a filter, and is fed back to supply tank. Thus, oil is prevented from accumulating in the base engine. The capacity of the scavenging pump is always greater than the oil pump. In this system a filter with a bypass valve is placed in between the scavenge pump and the supply tank. A separate oil cooler with either water or air as the cooling medium, is usually provided in the dry sum system to remove heat from the oil.

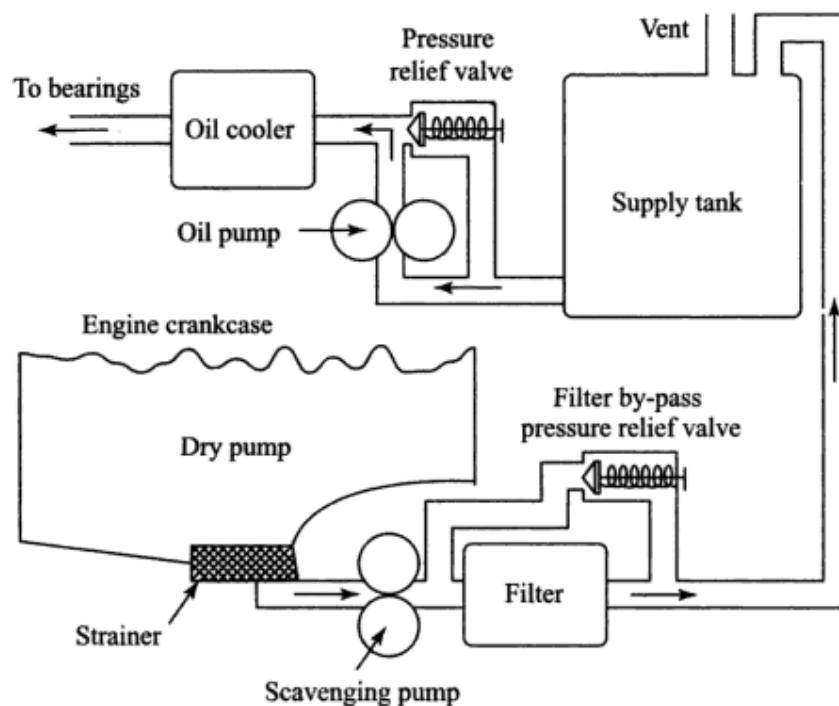

4. Crankcase ventilation

During the compression and the expansion strokes the gas inside the cylinder gets past the piston rings and enters the crankcase which is called the blow by. It contains water vapour and sulphuric acid, they might cause corrosion of steel parts in the crankcase. Removal of the blow by can be achieved effectively by passing constant stream of fresh air through crankcase known as crankcase ventilation. By doing so, not only all the water vapour but also a considerable proportion of the fuel in the blow by may remove from the crankcase.

The crankcase must have an air inlet and air outlet for the effective crankcase ventilation. The breather and oil filter forms a suitable inlet placed near the forward end of the case where fan blows the cooling air and an outlet opening is then provided near the rear end of the engine block and a tube is taken from this outlet to a point below the crankcase where rapid flow of air flows past its outlet when the vehicle is in motion causing an ejector effect.

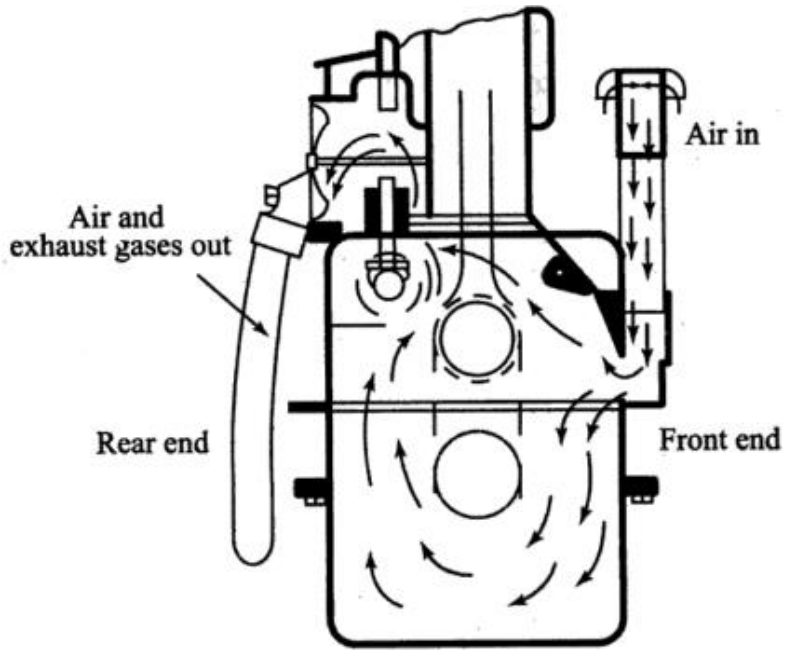

Cooling Systems of IC Engines

Parameters Affecting Engine Heat Transfer

1. Fuel-Airratio
2. CompressionRatio
3. SparkAdvance
4. Engine Output
5. Cylinder WallTemperature

We know that in case of Internal Combustion engines, combustion of air and fuel takes place inside the engine cylinder and hot gases are generated. The temperature of gases will be around 2000-2500 K. This is a very high temperature and may result into burning of oil film between the moving parts and may result into seizing or welding of the same. So, this temperature must be reduced to about 175-220 K at which the engine will work most efficiently. Too much cooling is also not desirable since it reduces the thermal efficiency. So, the object of cooling system is to keep the engine running at its most efficient operating temperature.

It is to be noted that the engine is quite inefficient when it is cold and hence the cooling system is designed in such a way that it prevents cooling when the engine is warming up and till it attains to maximum efficient operating temperature, then it starts cooling.

Characteristics of an efficient cooling system:

It should be capable of removing about 30 % of heat generated in the combustion chamber while maintaining the optimum temperature of the engine under all operating conditions of the engine. It should remove heat at faster rate when engine is hot. However, during starting of the engine the cooling should be minimum, So that the working parts of the engine reach their operating temperatures in a short time.

There are mainly two types of cooling systems:

- (a) Air cooled system, and
- (b) Liquid cooled system.

Air Cooled System

Air cooled system is generally used in small engines say up to 15-20 kW and in aero plane engines. In this system fins or extended surfaces are provided on the cylinder walls, cylinder head, etc. Heat generated due to combustion in the engine cylinder will be conducted to the fins and when the air flows over the fins, heat will be dissipated to air.

The amount of heat dissipated to air depends upon:

- (a) Amount of air flowing through the fins.
- (b) Fin surface area.
- (c) Thermal conductivity of metal used for fins.

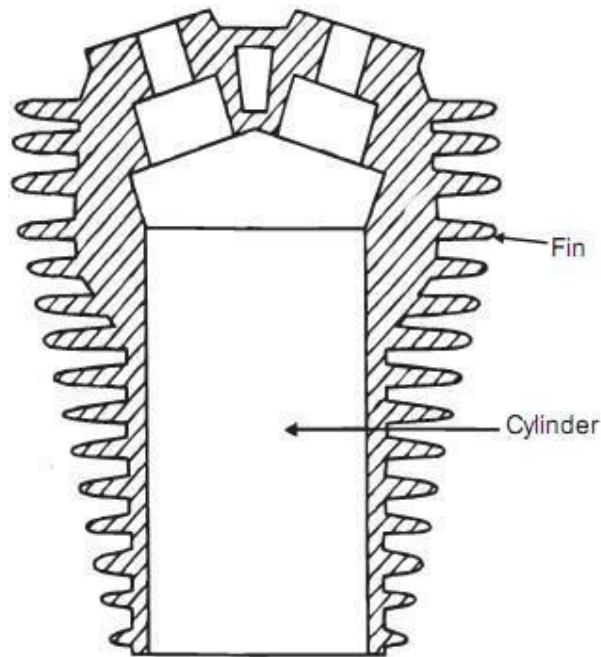

Cylinder with Fins

Advantages of Air Cooled System Following are the advantages of air cooled system:

- (a) Radiator/pump is absent hence the system is light.
- (b) In case of water cooling system there are leakages, but in this case there are no leakages.
- (c) Coolant and antifreeze solutions are not required.
- (d) This system can be used in cold climates, where if water is used it may freeze.

Disadvantages of Air Cooled System

- (a) Comparatively it is less efficient.
- (b) It is used in aero planes and motorcycle engines where the engines are exposed to air directly.

2. Liquid cooled system

In this system mainly water is used and made to circulate through the jackets provided around the cylinder, cylinder-head, valve ports and seats where it extracts maximum heat.

Water cooling can be carried out by any one of the following five methods

- i. Direct or non-return system
- ii. Thermosyphon system
- iii. Forced circulation cooling system
- iv. Evaporative cooling system
- v. Pressure cooling system

i. Direct or non-return system:

This system is useful for large installations where plenty of water is available. The water from a storage tank is directly supplied through an inlet valve to the engine cooling water jacket. The hot water is not cooled for reuse but simply discharge.

ii. Thermosyphon system

In this system the circulation of water is due to difference in temperature (i.e. difference in

densities) of water. So in this system pump is not required but water density difference only.

is circulated because of

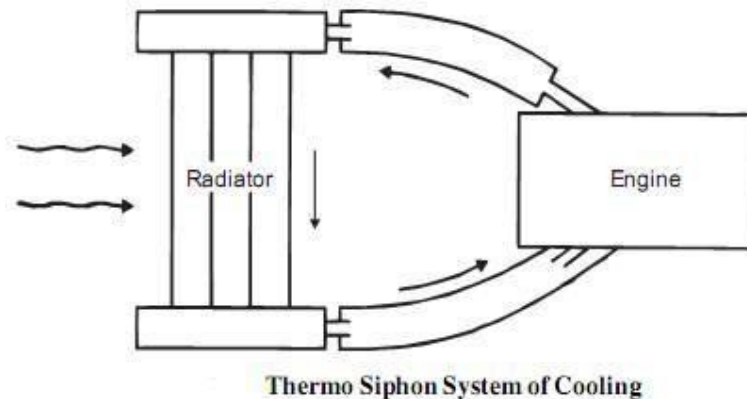

iii. *Forced circulation cooling system*

In this system circulation of water is obtained by a pump. This pump is driven by means of engine output shaft through V-belts.

Water cooling system mainly consists of:

- (a) Radiator,
- (b) Thermostat valve,
- (c) Water pump,
- (d) Fan,
- (e) Water Jackets, and
- (f) Antifreeze mixtures.

Radiator It mainly consists of an upper tank and lower tank and between them is a core. The upper tank is connected to the water outlets from the engine's jackets by a hose pipe and the lower tank is connected to the jacket inlet through water pump by means of hose pipes.

When the water is flowing down through the radiator core, it is cooled partially by the fan which blows air and partially by the air flow developed by the forward motion of the vehicle. As shown through water passages and air passages, water and air will be flowing for cooling purpose. It is to be noted that radiators are generally made out of copper and brass and their joints are made by soldering.

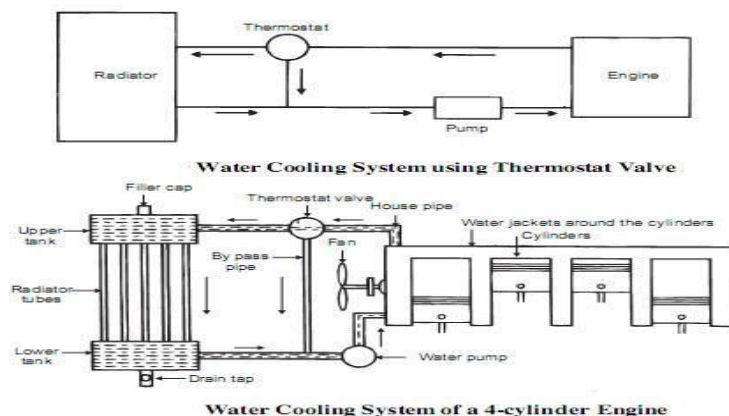

Thermostat Valve It is a valve which prevents flow of water from the engine to radiator, so that engine readily reaches to its maximum efficient operating temperature. After attaining maximum efficient operating temperature, it automatically begins functioning. Generally, it prevents the water below 70°C. Figure shows the Bellow type thermostat valve which is generally used. It contains a bronze bellow containing liquid alcohol. Below is connected to the butterfly valve disc through the link.

When the temperature of water increases, the liquid alcohol evaporates and the bellow expands and in turn opens the butterfly valve, and allows hot water to the radiator, where it is cooled.

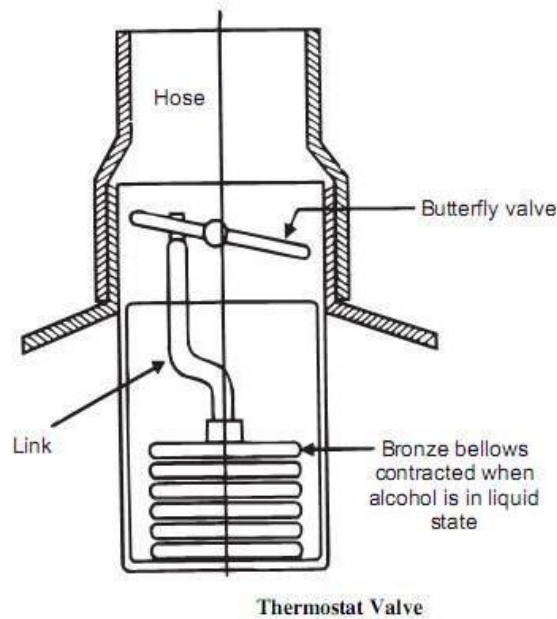

Water Jackets Cooling water jackets are provided around the cylinder, cylinder head, valve seats and any hot parts which are to be cooled. Heat generated in the engine cylinder, conducted through the cylinder walls to the jackets. The water flowing through the jackets absorbs this heat and gets hot. This hot water will then be cooled in the radiator.

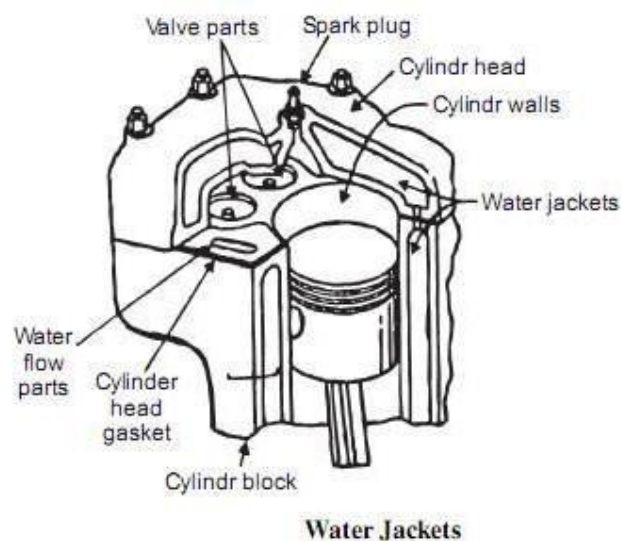

Antifreeze Mixture In western countries if the water used in the radiator freezes because of cold climates, then ice formed has more volume and produces cracks in the cylinder blocks, pipes, and

radiator. So, to prevent freezing antifreeze mixtures or solutions are added in the cooling water.

The ideal antifreeze solutions should have the following properties:

- (a) It should dissolve in water easily.
- (b) It should not evaporate.
- (c) It should not deposit any foreign matter in cooling system.
- (d) It should not have any harmful effect on any part of cooling system.
- (e) It should be cheap and easily available.
- (f) It should not corrode the system.

No single antifreeze satisfies all the requirements. Normally following are used as antifreeze solutions:

- (a) Methyl, ethyl and isopropyl alcohols.
- (b) A solution of alcohol and water.
- (c) Ethylene Glycol.
- (d) A solution of water and Ethylene Glycol.
- (e) Glycerin along with water, etc.

Liquid-Cooling System Advantages

- i. Compact design of engines with appreciably smaller frontal area is possible.
- ii. The fuel consumption of high compression liquid-cooled engines are rather lower than air cooled ones.
- iii. Because of the even cooling of cylinder barrel and head due to jacketing makes it possible to reduce the cylinder head and valves seat temperatures.
- iv. In case of liquid cooled engines, installation is not necessarily at the front of the mobile vehicles, aircraft etc. as the cooling system can be conveniently located wherever required. This is not possible in case of air-cooled engines.
- v. The size of engine does not involve serious problems as far as the design of cooling systems is concerned. In case of air cooled engines particularly in high horsepower range difficulty is encountered in the circulation of requisite quantity of air for cooling purposes.

Limitations

- i. This is dependent system in which liquid circulation in the jackets is to be ensured by additional means.
- ii. Power absorbed by the pump for water circulation is considerable and this affects the power output of the engine.
- iii. In the event of failure of the cooling system serious damage may be caused to the engine.
- iv. Cost of the system is considerably high.
- v. System requires considerable maintenance of its various parts.

Air-Cooling System Advantages

- i. The design of the engine becomes simpler as no liquid jackets are required. The cylinder can have identical dimensions and be individually detachable and therefore cheaper to renew in case of accident etc.
- ii. Absence of cooling pipes, radiator etc, makes cooling system simpler thereby has minimum maintenance problems.
- iii. No danger of coolant leakage etc.

- iv. The engine is not subject to freezing troubles etc, usually encountered in case of watercooled engines.
- v. The weight of the air-cooled engine is less than that of liquid cooled engine, i.e power to weight ratio is improved.
- vi. In this case, the engine is rather a self-contained unit as it requires no external components like radiator, tank etc.
- vii. Installation of air cooled engine is easier.

Limitations

- i. Can be applied only to small and medium sized engines
- ii. In places where ambient temperatures are lower
- iii. Cooling is not uniform
- iv. Higher working temperatures compared to liquid cooling
- v. Produce more aerodynamic noise
- vi. Specific fuel consumption is slightly higher
- vii. Lower maximum allowable compression ratios.

Super Charging

The power output of an engine depends upon the amount of air inducted per unit time and the degree of utilization of this air, and the thermal efficiency of the engine.

Three possible methods utilized to increase the air consumption of an engine are as follows:

Increasing the piston displacement: This increases the size and weight of the engine, and introduces additional cooling problems.

Running the engine at higher speeds: This results in increased mechanical friction losses and imposes greater inertia stresses on engine parts.

Increasing the density of the charge:

This allows a greater mass of the charge to be inducted into the same volume.

Definition

The method of increasing the air capacity of an engine is known as supercharging. The device used to increase the air density is known as supercharger.

Supercharger is simply a blower or a compressor that provides a denser charge to the engine.

Objectives

For ground installations, it is used to produce a gain in the power output of the engine.

For aircraft installations, in addition to produce a gain in the power output at sea-level, it also enables the engine to maintain a higher power output as altitude is increased.

SI Engines

Supercharging in SI engine is employed only in aircraft and racing car engines. Apart from increasing the volumetric efficiency of the engine, supercharging results in an increase in the intake temperature of the engine.

This reduces the ignition delay and increases the flame speed. Both these effects result in a greater tendency to knock or pre-ignite. For this reason, the supercharged petrol engines employ lower compression ratios.

CI Engines

In case of CI engines, supercharging does not result in any combustion problem, rather it improves combustion. Increase of pressure and temperature of the inducted air reduces ignition delay, and

hence the rate of pressure rise results in a better, quieter and smoother
Methods of super charging

1. Mechanical Supercharger:

In this case, blower is driven by the engine crankshaft. The blower is usually a positive displacement type that runs at the engine speed.

This allows quick response to the throttle change.

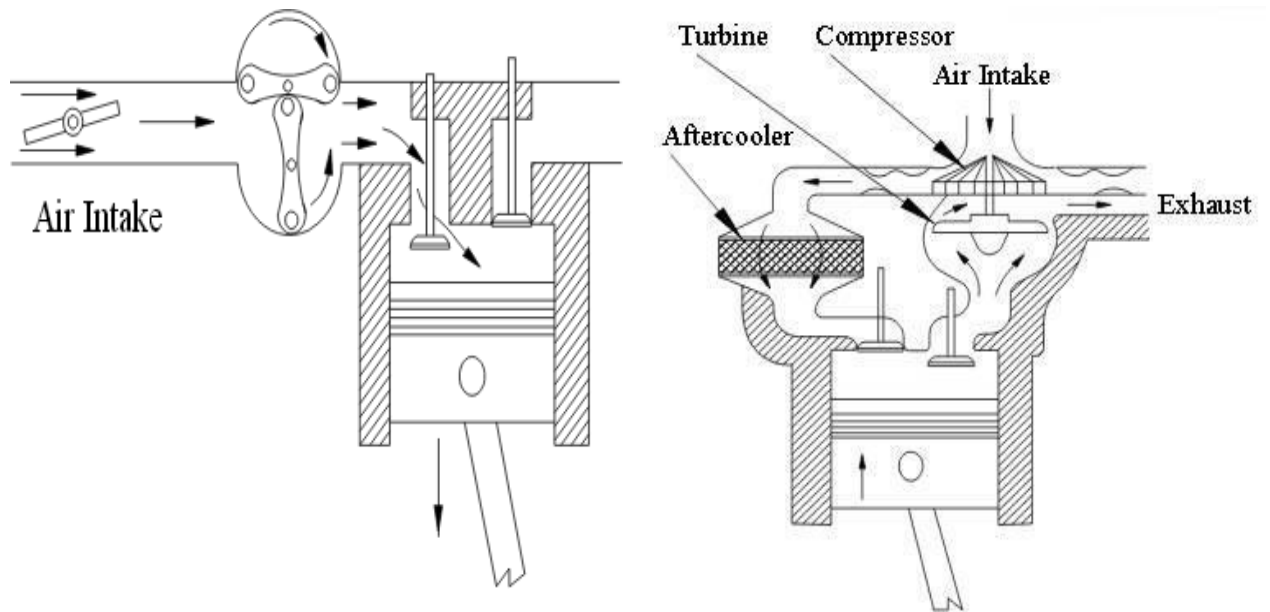

2. Turbocharger:

The blower/compressor and the turbine are mounted on the same shaft. The compressor is run by the turbine, and the turbine, in turn, is run by the exhaust gases.

Turbo lag

One of the main problems with turbochargers is that they do not provide an immediate power boost when you step on the gas. It takes a second for the turbine to get up to speed before boost is produced. This results in a feeling of lag when you step on the gas, and then the car lunges ahead when the turbo gets moving. One way to decrease turbo lag is to reduce the inertia of the rotating parts, mainly by reducing their weight. This allows the turbine and compressor to accelerate quickly, and start providing boost earlier.

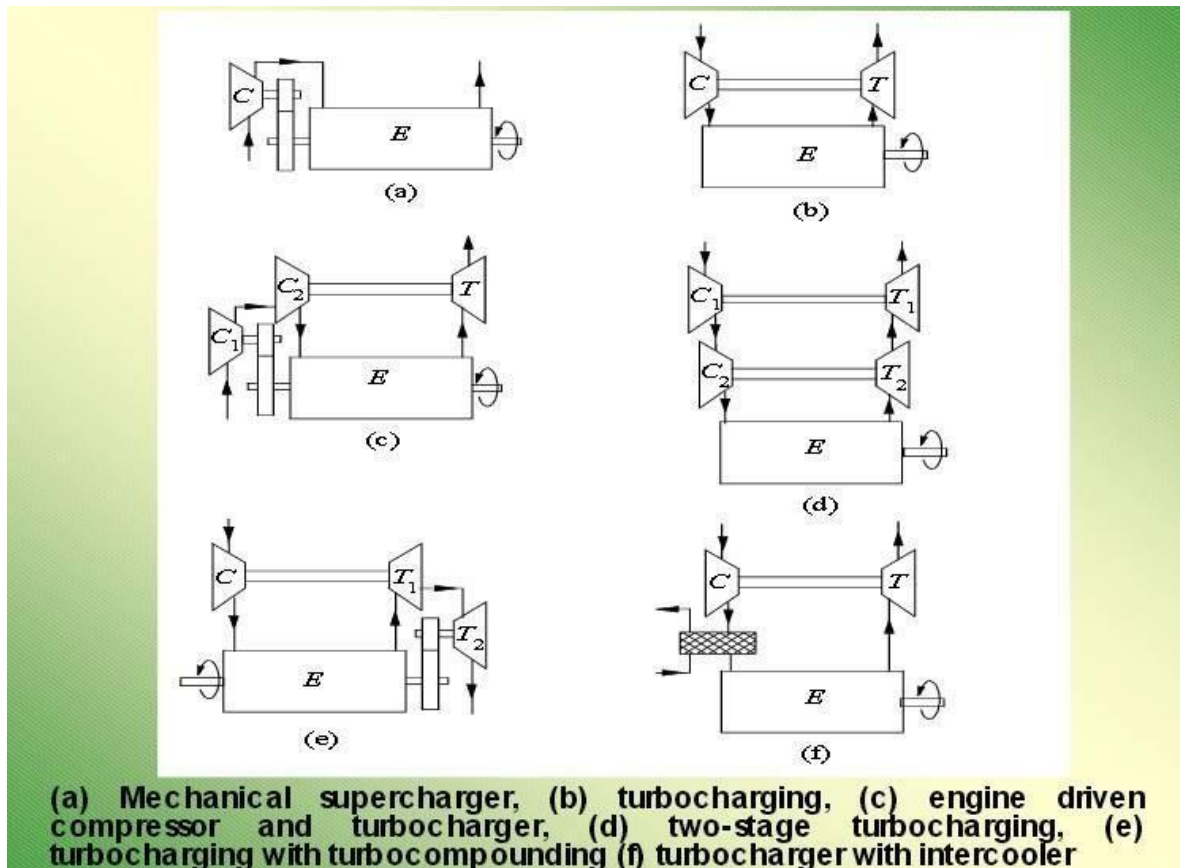

Use of After-coolers/Intercoolers

In the process of raising the input air pressure, supercharger also raises the inlet air temperature by compressive heating.

This is undesirable in SI engines. If the temperature at the start of the compression stroke is higher, all temperatures in the rest of the cycle will also be higher. This causes self-ignition. To avoid this, many superchargers are equipped with an after cooler that cools the compressed air to a lower temperature. The after cooler can be either an air-to-air heat exchanger or an air-to-liquid heat exchanger.

After-coolers/Intercoolers

The temperature drop through an after cooler is usually expressed in terms of effectiveness, defined as the ratio of the measured temperature drop to the maximum possible temperature drop that would bring the cooled fluid to the coolant temperature.

Use of After-coolers

The after coolers are not needed on superchargers used in CI engines, because there is no concerns about engine knock. After coolers are costly and takes up space in the engine compartment. For these reasons, superchargers on some automobiles do not have after coolers. These engines usually have reduced compression ratios to avoid problems of self- ignition.

Two-stage Supercharger

A single stage supercharger becomes prohibitive in size and weight for high altitude planes. Two stage superchargers are, therefore, used for high altitude aircraft. Two superchargers are used in tandem, and the charge is compressed in two stages. Such an arrangement produces the necessary

compression without the excessive size or speed of the impeller that would be required for a single stage supercharger of same capacity.

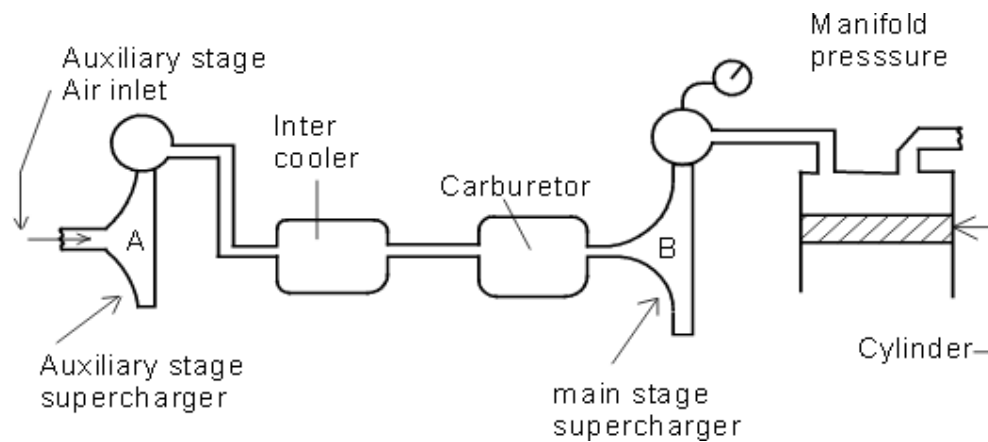

It also provides a convenient arrangement for the use of an intercooler between the stages to assist in keeping the temperature of the charge from exceeding the detonation limits due to compression. One typical arrangement of a two-stage supercharger is shown. At low altitudes, only the main stage (B) is used and the air enters through the main stage air inlet. At some altitude, where the main stage no longer has sufficient capacity to provide the mass of air required, the auxiliary stage is cut in, main stage air inlet is closed, and the air is inducted through the auxiliary air inlet. The auxiliary supercharger then compresses the air, which passes through the intercooler where its temperature is reduced, and then flows into main stage compressor where it is compressed further. The auxiliary stage sometimes may be two-speed, and the installation is known as a two-stage, two-speed supercharger.

Turbo-supercharger

A turbocharger or turbo-supercharger is often used for high altitude aircraft. Figure above represents a two-stage system in which the auxiliary stage is driven by energy remaining in the exhaust gas. At low altitudes, the auxiliary stage is not used and the exhaust gases are passed to the atmosphere through an open blast gate.

When it becomes necessary to use the auxiliary stage (A) at higher altitude, the blast gate is closed forcing the exhaust gases to pass through a turbine wheel, which in turn drives the auxiliary stage. This stage is thus a variable speed supercharger whose capacity is increased by increasing the flow of the exhaust gases through the turbine by reducing the blast gate opening. When the blast gate is fully closed, the maximum capacity of the supercharger can be obtained.

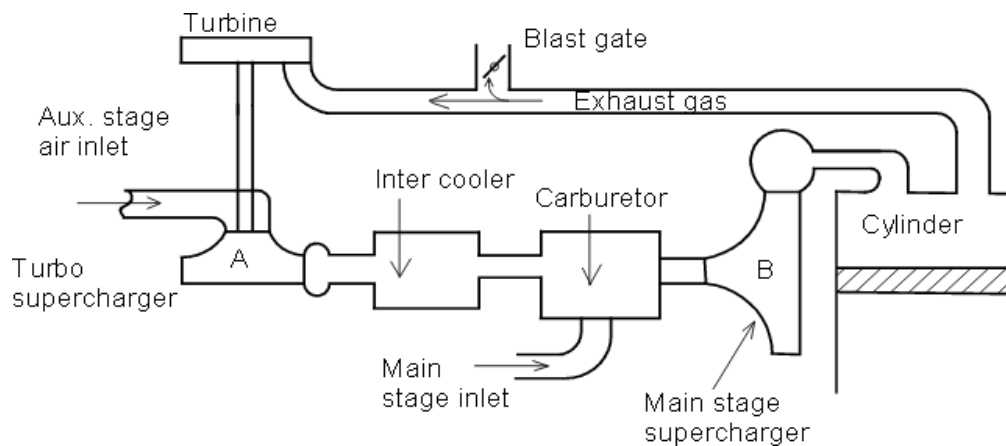

Turbo-supercharger

Effects of Supercharging

1. High poweroutput
2. Greater introduction of chagemass
3. Better atomization offuel
4. Better mixing of fuel andair
5. Better scavenging ofproducts
6. Better torque characteristic over the whole speedrange
7. Quicker acceleration ofvehicle
8. More complete and smoothcombustion
9. Inferior or poor ignition quality fuelused
10. Smoother operation and reduction in diesel knocktendency
11. Increase detonation tendency in SIengines
12. Improved coldstarting
13. Reduced exhaustsmoke
14. Reduced specific fuel consumption in turbocharging
15. Increased mechanicalefficiency
16. Increased thermalstress
17. Increased heat losses due to increasedturbulence
18. Increased gasloading
19. Increased valve overlap period of 60° to 160° of crankangle
20. Increased cooling requirements of pistons andvalves

HOMOGENEOUS MIXTURE

In spark-ignition engines a nearly homogeneous mixture of air and fuel is formed in the carburettor. Homogeneous mixture is thus formed outside the engine cylinder and the combustion is initiated inside the cylinder at a particular instant towards the end of the compression stroke. The flame front spreads over a combustible mixture with a certain velocity. In a homogeneous gas mixture the fuel and oxygen molecules are more or less, uniformly distributed.

Once the fuel vapour-air mixture is ignited, a flame front appears and rapidly spreads through the mixture. The flame propagation

is caused by heat transfer and diffusion of burning fuel molecules from the combustion zone to the adjacent layers of unburnt mixture. The flame front is a narrow zone separating the fresh mixture from the combustion products. The velocity with which the flame front moves, with respect to the unburned mixture in a direction normal to its surface is called the normal flame velocity.

In a homogeneous mixture with an equivalence ratio, ϕ , (*the ratio of the actual fuel-air ratio to the stoichiometric fuel-air ratio*) close to 1.0, the flame speed is normally of the order of 40 cm/s. However, in a spark-ignition engine the maximum flame speed is obtained when ϕ is between 1.1 and 1.2, i.e., when the mixture is slightly richer than stoichiometric.

If the equivalence ratio is outside this range the flame speed drops rapidly to a low value. When the flame speed drops to a very low value, the heat loss from the combustion zone becomes equal to the amount of heat-release due to combustion and the flame gets extinguished. Therefore, it is quite preferable to operate the engine within an equivalence ratio of 1.1 to 1.2 for proper combustion. However, by introducing turbulence and incorporating proper air movement, the flame speed can be increased in mixtures outside the above range.

Normal Combustion: When the flame travels evenly or uniformly across the combustion chamber.

Abnormal Combustion: When the combustion gets deviated from the normal behavior resulting in loss of performance or damage to the engine.

Combustion is dependent upon the rate of propagation of flame front (or flame speed).

Stages of Combustion

a → b : Compression b → c : Combustion c → d : Expansion

Ideally, entire pressure rise during combustion occurs at constant volume, i.e., when the piston is at TDC

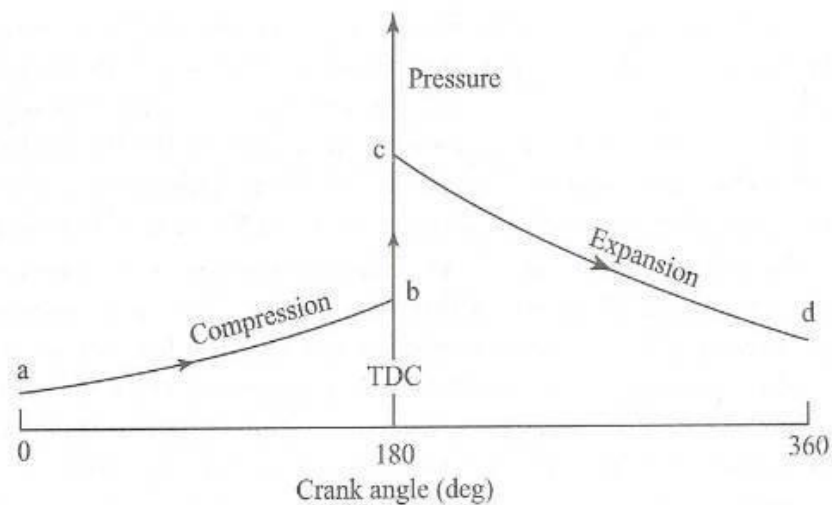

Actual p-θ diagram

- I. Ignition lag (A→B): Flame front begins to travel.
- II. Spreading of Flame (B→C): Flame spreads throughout the Combustion Chamber.
- III. Afterburning (C→D): C is the point of max. pressure, a few degrees after TDC. Power stroke begins.

First stage (A-B) Ignition lag/Preparation phase: in which growth and development of a self-propagating nucleus of flame takes place.

It is a chemical process and depends upon both temperature and pressure, the nature of the fuel and proportion of the exhaust residual gas.

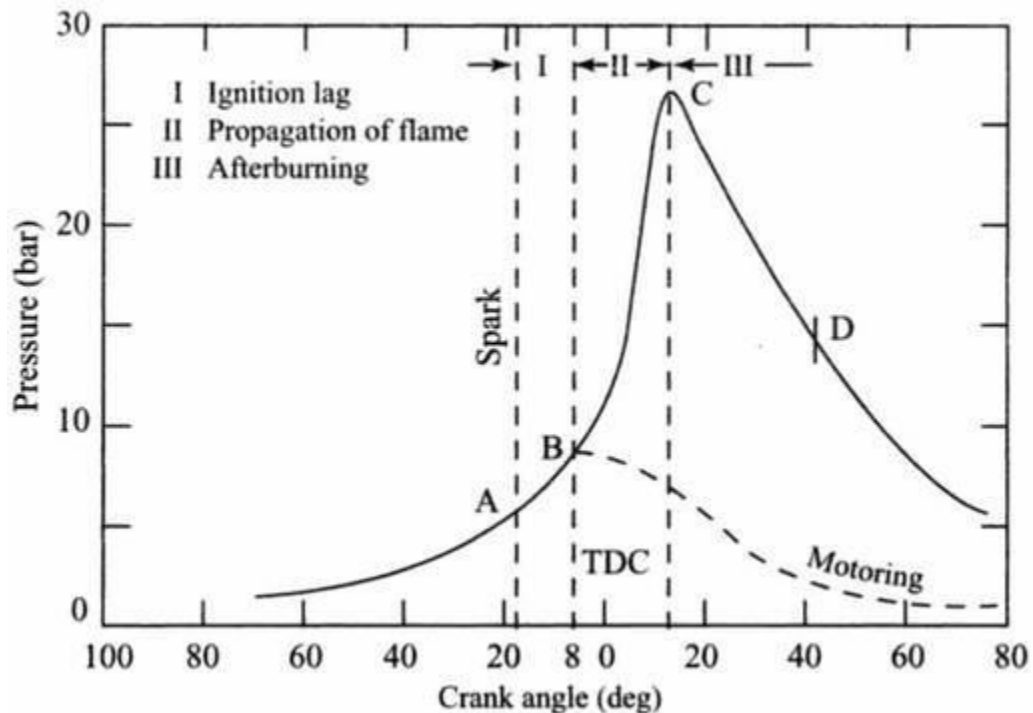

Second stage (B-C) Propagation of flame: It is physical one and it is concerned with the spread of the flame throughout the combustion chamber.

The starting point of the second stage is where the first measurable rise of pressure is seen on the indicator diagram.

In this the flame propagates practically at constant velocity. Heat transfer to the cylinder wall is low, because only a small part of the burning mixture comes in contact with the cylinder wall during this period.

The rate of heat release depends largely on the turbulence intensity and also on the reaction rate which is depends on the mixture composition. The rate of pressure rise is proportional to the rate of heat-release because during this stage, the combustion chamber volume remains practically constant.

Third stage (C-D) Afterburning: the starting point of third stage is usually taken as the instant at which the maximum pressure is reached.

The flame velocity decreases during this stage, the rate of combustion becomes low due to lower flame velocity and reduced flame front surface.

Since expansion stroke starts before this stage of combustion, with the piston moving away from the top dead center, there can be no pressure rise during this stage.

Flame front Propagation:

Efficient combustion the rate of propagation of the flame front within the cylinder is quite critical.

The reaction rate and transposition rate are two major factors.

The reaction rate is the resultant of a purely chemical combination process in which the flame eats its way into the unburned charge.

The transposition rate is due to the physical movement of the flame front relative to the cylinder wall and is also the result of the pressure differential between the burning gases and the unburnt gases in the combustion chamber.

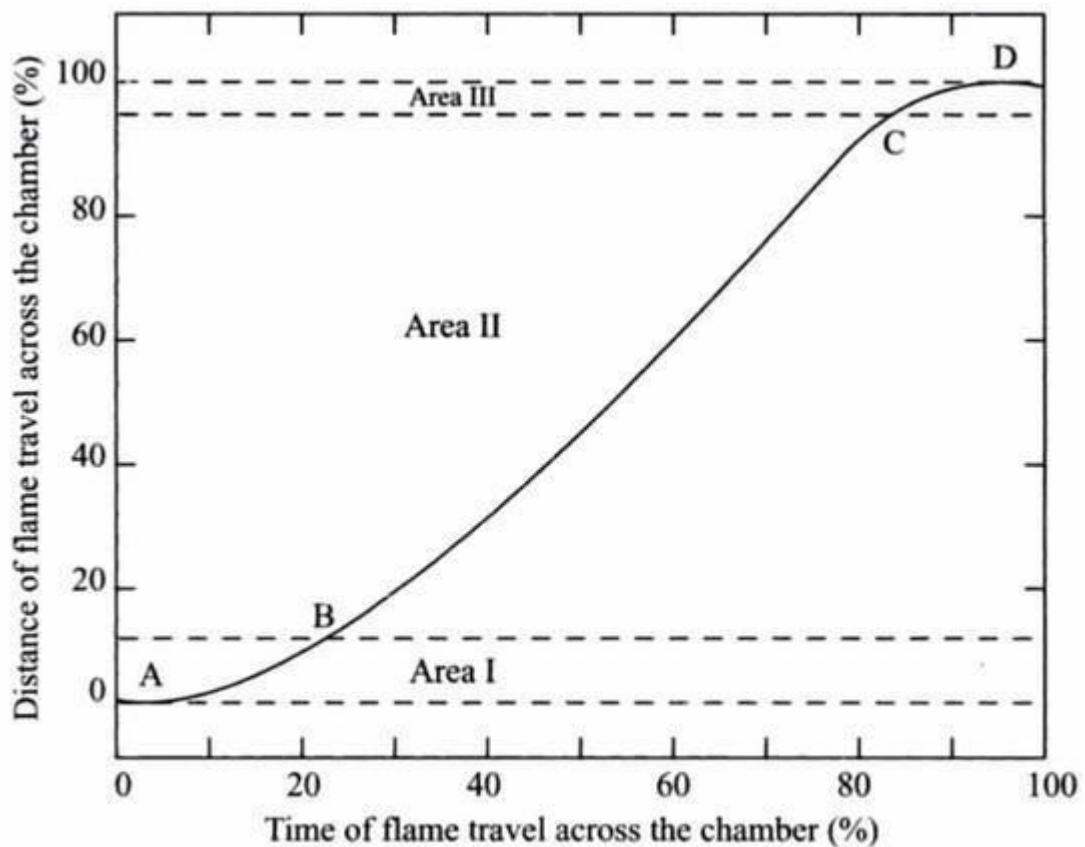

Details of Flame Travel

Factors influencing the flame speed:

The flame velocity influences the rate of pressure rise in the cylinder and it is related to certain types of abnormal combustion. There are several factors which affect the flame speed, to a varying degree, the most important being the turbulence and the fuel-air ratio.

Turbulence:

The flame speed is quite low in non-turbulent mixtures and increases with increasing turbulence. The turbulence in the incoming mixture is generated during the admission of fuel-air mixture through comparatively narrow sections of the intake pipe, valve openings etc., in the suction stroke.

Turbulence which is supposed to consist of many minute swirls appears to increase the rate of reaction and produce a high flame speed than that made up larger and fewer swirls.

Geometry of cylinder head and piston crown increases the turbulence during the compression stroke.

Effects of turbulence:

It increases the heat flow to the cylinder wall.

It accelerates the chemical reaction by initiate mixing of fuel and oxygen so that spark advance may reduce. So this helps burning lean mixture.

The increase of flame speed due to turbulence reduces the combustion duration and hence minimizes the tendency of abnormal combustion.

Excessive turbulence may extinguish the flame resulting in rough and noisy operation of the engine.

Fuel-Air Ratio: the high flame velocities (minimum time for complete combustion) are obtained with somewhat richer mixture. When the mixture is made leaner or richer than equivalent ration (1.2-1.3) the flame speed decreases.

Less thermal energy is released in the case of lean mixtures resulting in lower flame temperature.

Very rich mixtures lead to incomplete combustion which results again in release of less thermal energy.

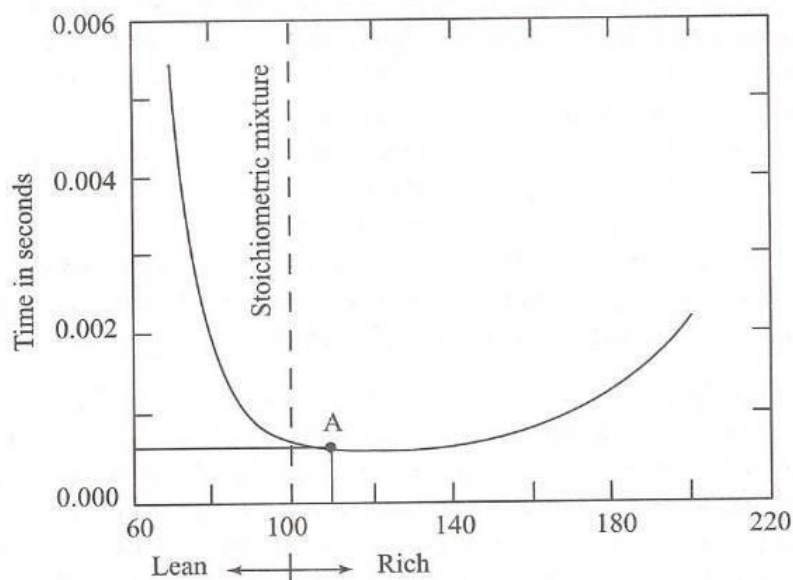

Temperature and pressure: flame speed will increase with an increase in intake temperature and pressure

Engine output: cycle pressure will increase with engine output is increased. When the output is decreased by throttling, the initial and final compression pressures decrease and dilution of working mixture increases. The smooth development of self-propagating nucleus of flame becomes unsteady and difficult. Poor combustion at low load for SI engines.

Engine speed: The flame speed increases almost linearly with engine speed since the increase in engine speed increases the turbulence inside the cylinder.

The crank angle required for the flame propagation during the entire phase of combustion, will be

remain nearly constant at all speeds.

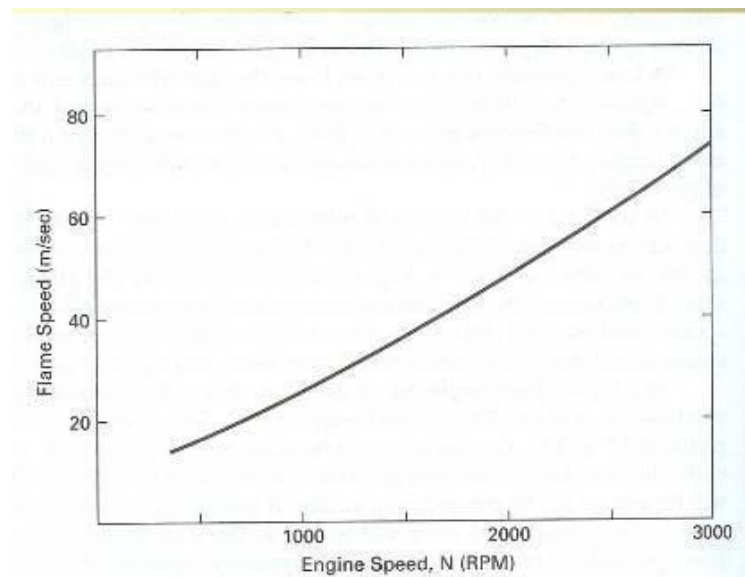

Engine size: the size of engine does not have much effect on the rate of flame propagation. In large engines the time required for complete combustion is more because the flame has to travel a longer distance. This requires increased crank angle duration during the combustion. This one of the reasons why large sized engines are designed to operate at low speeds.

Abnormal Combustion:

In normal combustion, the flame initiated by the spark travels across the combustion chamber in a fairly uniform manner. Under certain operating conditions the combustion deviates from its normal course leading to loss of performance and possible damage to the engine. This type of combustion may be termed as an abnormal combustion or knocking combustion. The consequences of this abnormal combustion process are the loss of power, recurring pre-ignition and mechanical damage to the engine.

Rate of pressure rise:

The rate of pressure rise in an engine combustion chamber exerts a considerable influence on the peak pressure developed, the power produced and the smoothness with which the forces are transmitted to the piston. The rate of pressure rise is mainly dependent upon the mass rate of combustion of mixture in the cylinder.

High peak pressures closer to TDC produce greater force acting through a large part of the power stroke and hence increase the power output of the engine.

The higher rate of pressure rise causes rough running of the engine because of vibrations produced in the crankshaft rotation. It also tends knocking.

A compromise between these opposing factors is accomplished by designing and operating the engine in such a manner that approximately one-half of the maximum pressure is reached by the time the piston reaches TDC.

Effect of Ignition: Constant Volume Cycle

Because of ignition lag, it is necessary to ignite the charge in the cylinder some degrees before the crankshaft reaches TDC. The number of degrees before TDC at which ignition occurs is called Ignition Advance.

The optimum angle of advance allows combustion to cease just after TDC, so that maximum possible pressure is built at a point just at the beginning of expansion stroke. This is shown as the normal curve, indicating smooth engine running.

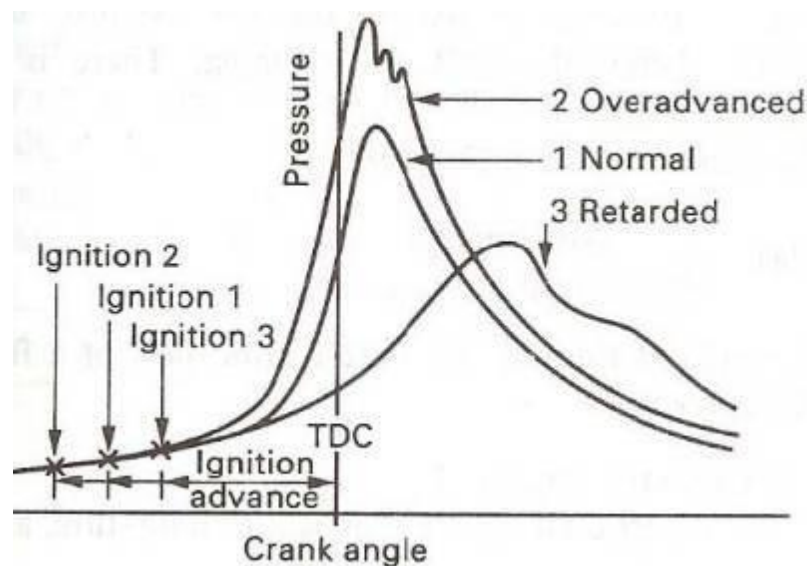

Effect of Over-advanced ignition

When the engine ignition is over-advanced, combustion is initiated too early and the cylinder pressure begins to rise rapidly while the piston is still trying to complete its compression stroke. This creates excessive cylinder pressures and may even produce shock waves in the cylinder as illustrated by the ragged top on curve 2. An over-advanced engine will run rough, it will tend to overheat resulting in loss of power.

When the engine ignition is retarded (curve 3), combustion is initiated late. In fact, combustion will continue while the piston is sweeping out its power stroke. Maximum pressure will occur late, and will not as high as that of the normal case. A retarded engine will produce less power output, and due to the late burning the engine will run hot, and may cause damage to the exhaust valves and ports.

Phenomenon of knocking in SI engine

Auto ignition

A mixture of fuel and air can react spontaneously and produce heat by chemical reaction in the absence of flame to initiate the combustion or self-ignition. This type of self-ignition in the absence of flame is known as Auto-Ignition. The temperature at which the self-ignition takes place is known as self-igniting temperature. The pressure and temperature abruptly increase due to auto-ignition because of sudden release of chemical energy.

Pre -Ignition

Pre-ignition is the ignition of the homogeneous mixture of charge as it comes in contact with hot surfaces, in the absence of spark. Auto ignition may overheat the spark plug and exhaust valve and it remains so hot that its temperature is sufficient to ignite the charge in next cycle during the compression stroke before spark occurs and this causes the stroke before spark occurs and this causes the Pre-ignition of the charge.

Pre-ignition is initiated by some overheated projecting part such as the sparking plug electrodes; exhaust valve head, metal corners in the combustion chamber, carbon deposits or protruding cylinder head gasket rim etc.

Effects of Pre-ignition

- It increase the tendency of knocking in the engine
- It increases heat transfer to cylinder walls because high temperature gas remains in contact with for a long time
- Pre-ignition in a single cylinder will reduce the speed and power output
- Pre-ignition may cause seizure in the multi-cylinder engines, only if only cylinders have pre-ignition

Knocking

Knocking is due to auto ignition of end portion of unburned charge in combustion chamber. As the normal flame proceeds across the chamber, pressure and temperature of unburned charge increase due to compression by burned portion of charge. This unburned compressed charge may auto ignite under certain temperature condition and release the energy at a very rapid rate compared to normal combustion process in cylinder. This rapid release of energy during auto ignition causes a high pressure differential in combustion chamber and a high pressure wave is released from auto ignition region. The motion of high pressure compression waves inside the cylinder causes vibration of engine parts and pinging noise and it is known as knocking or detonation. This pressure frequency or vibration frequency in SI engine can be up to 5000 Cycles per second

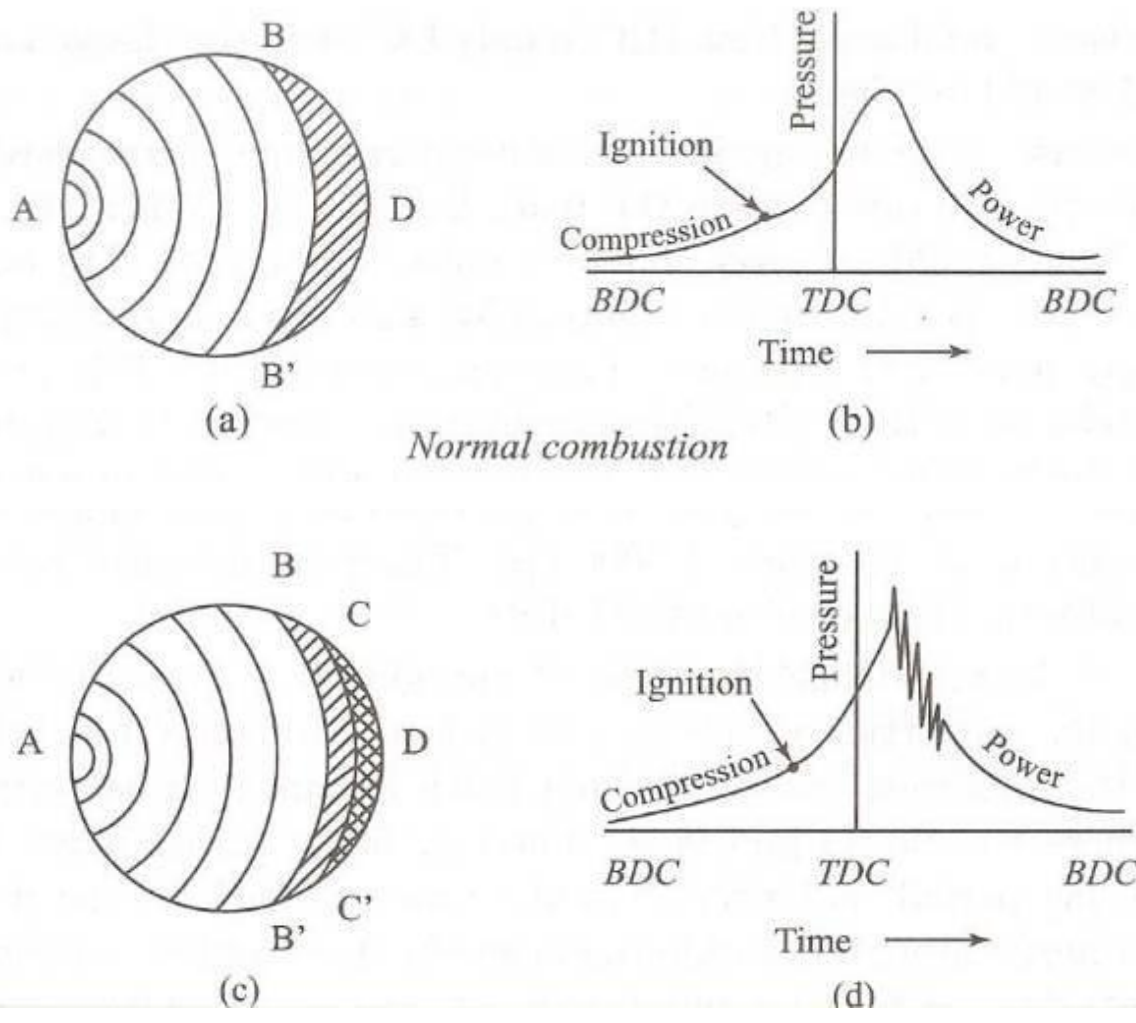

Normal combustion

Flame travels from A→D and compresses the end charge BB'D and raises its temperature. Temperature also increases due to heat transfer from the flame front. Now, if the final temperature is less than the auto ignition temperature, Normal Combustion occurs and charge BB'D is consumed by the flame itself. Now, if the final temperature is greater than and equal to the auto-ignition temperature, the charge BB'D auto-ignites (knocking). A second flame front develops and moves in opposite direction, where the collision occurs between the flames. This causes severe pressure pulsation, and leads to engine damage/failure

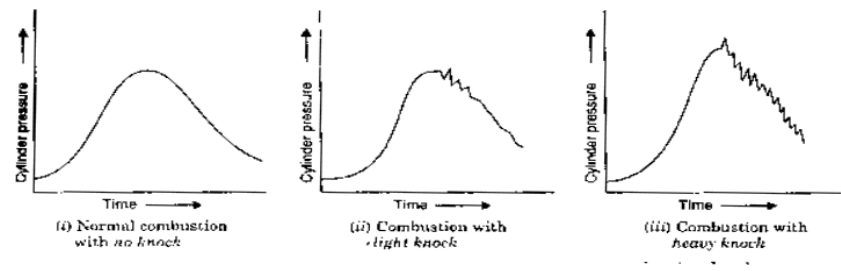

Knocking is undesirable as it affects the engine performance and life, as it abruptly increases sudden large amount of heat energy. It also put a limit on increases sudden large amount of heat energy. It also put a limit on compression ratio at which engine can be operated which directly affects the engine efficiency and output.

Effect of knocking

1. **Noise and roughness.** Knocking produces a loud pulsating noise and pressure waves. These waves which vibrates back and forth across the cylinder. The presence of vibratory motion causes crankshaft vibrations and the engine runs rough.
2. **Mechanical damage.**
 - (a) High pressure waves generated during knocking can increase rate of wear of parts of combustion chamber. Sever erosion of piston crown (of combustion chamber. Sever erosion of piston crown (in a manner similar to that of marine propeller blades by cavitation), cylinder head and Cylinder head and pitting of inlet and outlet valves may result in complete wreckage of the engine.
 - (b) Knocking is very dangerous in engines having high noise level. In small engines the knocking noise is easily detected and the corrective measures can be taken but in aero-engines it is difficult to detect knocking noise and hence corrective measures cannot be taken. Hence severe detonation may persist for a long time which may ultimately result in complete wreckage of the piston.
3. **Carbon deposits.** Detonation results in increased carbon deposits.
4. **Increase in heat transfer.** Knocking is accompanied by an increase in the rate of heat transfer to the combustion chamber walls.

The increase in heat transfer is due to two reasons.

The minor reason is that the maximum temperature in a) knocking engine is about 150°C higher than in a non –knocking engine, due to rapid completion of combustion

The major reason for increased heat transfer is the scouring away of protective layer of inactive stagnant gas on the cylinder walls due to pressure waves. The inactive layer of gas normally reduces the heat transfer by protecting the combustion and piston crown from direct contact with flame.

5. **Decrease in power output and efficiency.** Due to increase in the rate of heat transfer the power output as well as efficiency of a **knocking** engine decreases.

Effect of engine operating variables on the SI engine knocking

The various engine variables affecting knocking can be classified as:

I. Temperature factors

1. **Compression ratio (CR):** When CR ratio increases, p and T increase and an overall increase in density of charge raises the knocking tendency.

2. **Mass of inducted charge:** A reduction in the mass of inducted charge (by throttling or by reducing the amount of supercharging) reduces both temperature and density at the time of ignition. This decreases the knocking tendency.
3. **Inlet temperature of mixture:** An increase in the inlet temperature of mixture makes the compression temperature higher. This increases the knocking tendency. Further, volumetric efficiency is lowered. Hence, a lower inlet temperature is always preferred. However, it should not be too low to cause starting and vaporization problems.
4. **Temperature of the Combustion Chamber wall**
5. **Power Output of Engine**

II. Density factors

Increasing the density of un-burnt mixture will increase the possibility of knock in the engine. The density of un-burnt mixture will increase the possibility of knock in the engine.

- The engine parameters which affect the density are as follows:
- Increased compression ratio increases the density.
- Increasing the load opens the throttle valve more and thus the density.
- Supercharging increases the density of the mixture.
- Increasing the inlet pressure increases the overall pressure during the cycle. The high pressure end gas decreases the delay period which increases the tendency of knocking.

Retarding spark timing: Having a spark closer to TDC, peak pressures are reached down the on the power stroke, and are of lower magnitudes. This might reduce the knocking tendency, however, it will affect the brake torque and power output.

III. Time factors: Increasing the flame speed or the ignition lag will tend to reduce the tendency to knock.

1. **Turbulence:** Increase of turbulence increases the flame speed and reduces the time available for the end charge to reach auto-ignition condition. This reduces the knocking tendency.
2. **Engine size:** Flame requires more time to travel in Combustion Chamber of larger engines. Hence, larger engines will have more tendency to knock.
3. **Engine speed:** An increase in engine speed increases the turbulence of the mixture considerably resulting in increased flame speed. Hence, knocking tendency reduces at higher engine speeds.
4. **Spark plug locations:** To minimize the flame travel distance, spark plug is located centrally. For larger engines, two or more spark plugs are located to achieve this.

IV. Composition factors: These include ratio of air-fuel mixture, and the properties of fuel employed in the engine.

1. **Fuel-air ratio:** The flame speeds are affected by fuel-air ratio. Also, the flame temperature and reaction time are different for different fuel-air ratios.
2. **Octane value:** In general, paraffin series of hydrocarbon have the maximum and aromatic series

the minimum tendency to knock. The naphthene series comes in between the two.

To provide a standard measure of a fuel's ability to resist knock, a scale has been devised in which fuels are assigned an **octane number** ON. The octane number determines whether or not a fuel will knock in a given engine under given operating conditions. By definition, normal heptane ($n\text{-C}_7\text{H}_{16}$) has an octane value of zero and isooctane (C_8H_{18}) has a value of 100. The higher the octane number, the higher the resistance to knock. Blends of these two hydrocarbons define the knock resistance of intermediate octane numbers: e.g., a blend of 10% n-heptane and 90% isooctane has an octane number of 90. A fuel's octane number is determined by measuring what blend of these two hydrocarbons matches the test fuel's knock resistance.

Anti-knocks additives

- Ethyl tetrachloride ($\text{TEO})\text{Pb}(\text{C}_2\text{H}_5)_4$
- Ethyl alcohol(ethanol)
- Methyl alcohol(methanol)
- Tetra-butyl alcohol(TBA)
- Ester methyl-tetra-butyl(MTBE)
- Ester tetra-amyl-methyl(TAME)

iso-octane	10.96
n-heptane	3.75

3. **Humidity of air:** Increasing atmospheric humidity decreases the tendency to knock by decreasing the reaction time of the fuel

Design Considerations

- Minimal flame travel
- The exhaust valve and spark plug should be close together
- Sufficient turbulence
- A fast combustion, low variability
- High volumetric efficiency
- Minimum heat loss to combustion walls
- Low fuel octane requirement

Summary of Variables Affecting Knock in an SI Engine

Increase in variable	Major effect on unburned reduce charge	Action to be taken to knocking	Can operator usually control?
Compression ratio	Increases temperature & pressure	Reduce	No
Mass of charge inducted	Increases pressure	Reduce	Yes
Inlet temperature	Increases temperature	Reduce	In some cases
Chamber wall temperature	Increases temperature	Reduce	Not ordinarily
Spark advance	Increases temperature & pressure	Retard	In some cases
A/F ratio	Increases temperature &	Make very rich	In some cases
Turbulence	Decreases time factor	Increase	Somewhat (through engine speed)
Engine speed	Decreases time factor	Increase	Yes
Distance of flame travel	Increases time factor	Reduce	No

Combustion in CI Engines

In a CI engine the fuel is sprayed directly into the cylinder and the fuel-air mixture ignites spontaneously in diesel engines, only air is send into the combustion chamber during induction. This air is compressed during the compression stroke and towards the end of compression stroke, fuel is injected by the fuel-injection system into the cylinder - just before the desired start of combustion. Liquid fuel is injected at high velocities as one or more jets through small orifices or nozzles in the injector tip. The fuel atomizes into small droplets and penetrates into the combustion chamber - the droplets vaporize and mix with high-temperature and high-pressure cylinder air

Combustion in a CI engine is quite different from that of an SI engine. While combustion in

an SI engine is essentially a flame front moving through a homogeneous mixture, combustion in a CI engine is an unsteady process occurring simultaneously in many spots in a very non-homogeneous mixture controlled by fuel injection. Air intake into the engine is un-throttled, with engine torque and power output controlled by the amount of fuel injected per cycle. Only air is contained in the cylinder during compression stroke, and a much higher compression ratio (12 to 24) are used in CI engines. In addition to swirl and turbulence of the air, a high injection velocity is needed to spread the fuel throughout the cylinder and cause it to mix with the air.

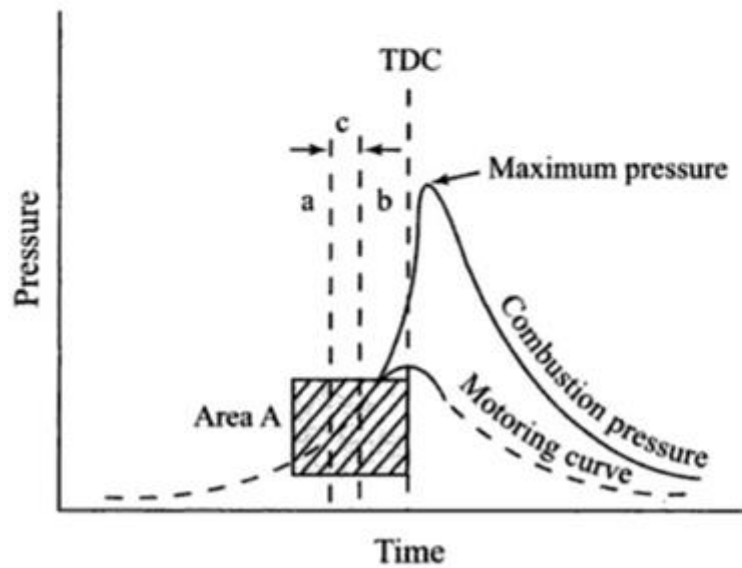
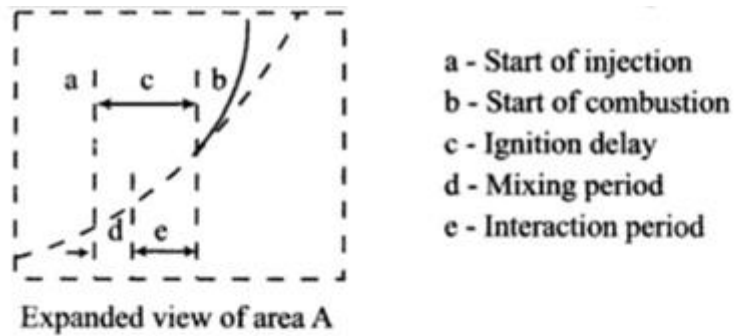

Cylinder pressure as a function of crank angle/Time for a CI engine.

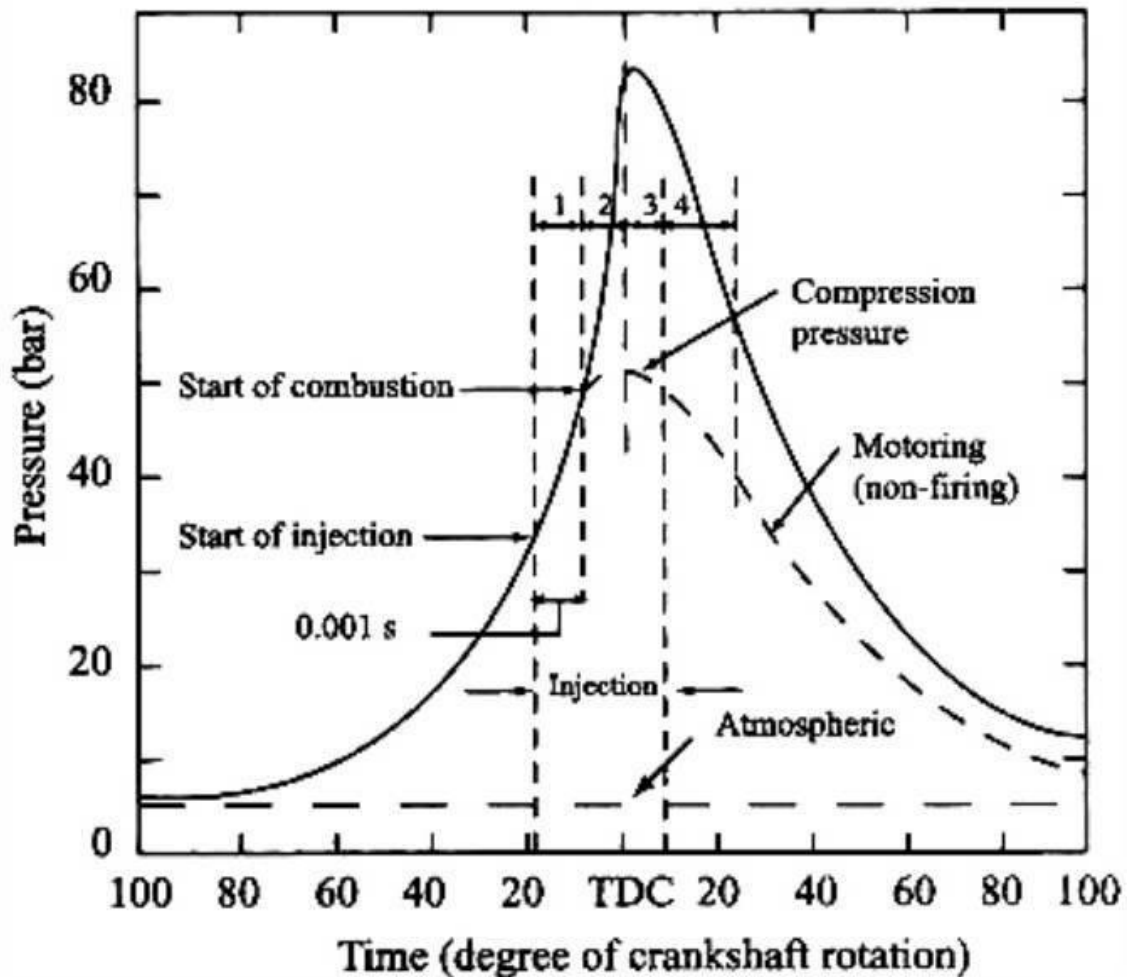

Stages of Combustion

1. Ignition Delay period /Pre-flamecombustion.

The fuel does not ignite immediately upon injection into the combustion chamber. There is a definite period of inactivity between the time of injection and the actual burning the actual burning this period is known as the ignition delay period. In Figure 2. the delay period is shown on pressure crank angle (or time) diagram between points a and b. Points "a" represents the time of injection and point "b" represents the time of combustion. The ignition delay period can be divided into two parts, the physical delay and the chemical delay. The delay period in the CI engine exerts a very great influence on both engine design and performance. It is of extreme importance because of its effect on both the combustion rate and knocking and also its influence on engine starting ability and the presence of smoke in the exhaust.

2. Period of RapidCombustion

The period of rapid combustion also called the uncontrolled combustion, is that phase in which the pressure rise is rapid. During the delay period, a considerable amount of fuel is accumulated in combustion chamber, these accumulated fuel droplets burns very rapidly causing a steep rise in pressure. The period of rapid combustion is counted from end of delay period or the beginning of the combustion

to the point of maximum pressure on the indicator diagram. The rate of heat- release is maximum during this period.

This is also known as uncontrolled combustion phase, because it is difficult to control the amount of burning/ injection during the process of burning. It may be noted that the pressure reached during the period of rapid combustion will depend on the duration of the delay period (the longer the delay the more rapid and higher is the pressure rise since more fuel would have been present in the cylinder higher is the pressure rise since more fuel would have been present in the cylinder before the rate of burning comes under control).

3. Period of Controlled Combustion

The rapid combustion period is followed by the third stage, the controlled combustion. The temperature and pressure in the second stage are so high that fuel droplets injected burn almost as they enter and find the necessary oxygen and any further pressure rise can be controlled by injection rate. The period of controlled combustion is assumed to end at maximum cycle temperature.

MODULE- III - A

Engine Performance Parameters

Engine Performance Parameters

The performance of the engine depends on inter relationship between power developed, speed and the specific fuel consumption at each operating condition within the useful range of speed and load.

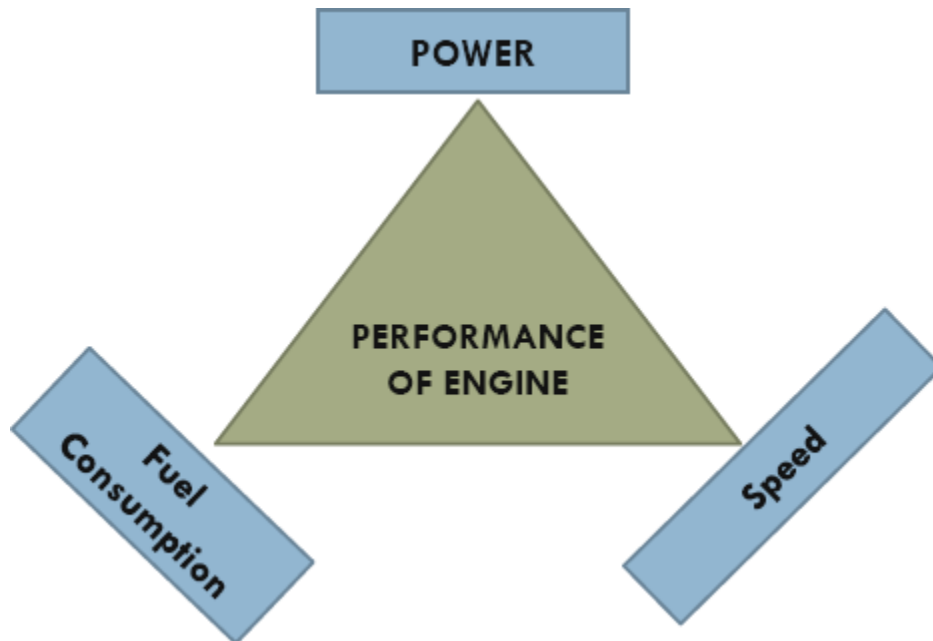

Internal combustion engine should generally operate within a useful range of speed. Some engines are made to run at fixed speed by means of a speed governor which is its rated speed. At each speed within the useful range, the power output varies and it has a maximum usable value. The specific fuel consumption varies with load and speed.

Absolute Rated Power: The highest power which the engine could develop at sea level with no arbitrary limitation on speed, fuel-air ratio or throttle opening.

Maximum rated power: The highest power an engine is allowed to develop for short periods of operation.

Normal rated power: The highest power an engine is allowed to develop in continuous operation.

Rated speed: The crank shaft rotational speed at which rated power is developed.

□ The performance of an engine is judged by quantifying its efficiencies.

Five important engine efficiencies are

Indicated thermal efficiency (η_{ith})

Brake thermal efficiency (η_{bth})

Mechanical efficiency (η_m)

Volumetric efficiency (η_v)

Relative efficiency or Efficiency ratio (η_{rel})

- Other Engine performance Parameters
 - Mean effective pressure (MEP or P_m)
 - Mean piston speed (sp)
 - Specific power output (P_s)
 - Specific fuel consumption (SFC)
 - Inlet-valve Mach Index (Z)
 - Fuel-air or air-fuel ratio (F/A or A/F)
 - Calorific value of the fuel (CV)

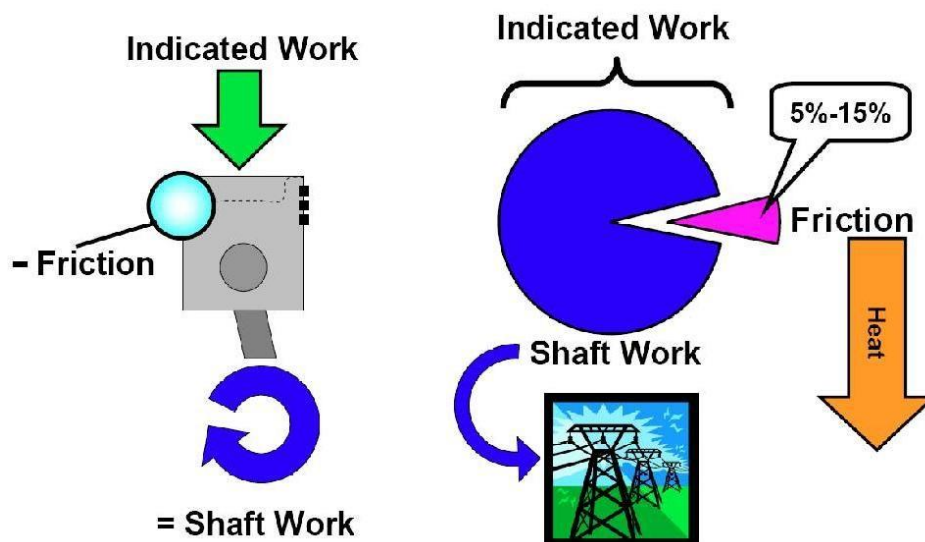
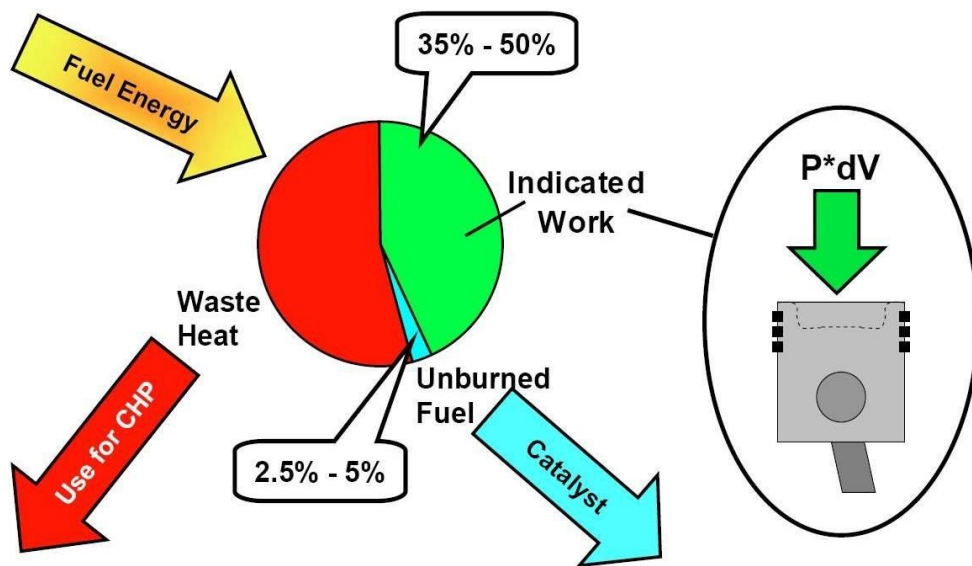

Indicated Power (ip) or (Pi)

Indicated Work

$$W_i = \int P \, dV$$

Negative work done by piston due to charge compression

+

Positive work done to the piston due to heat release and expansion

=

Positive work done by compression/expansion cycle
*** indicated work ***

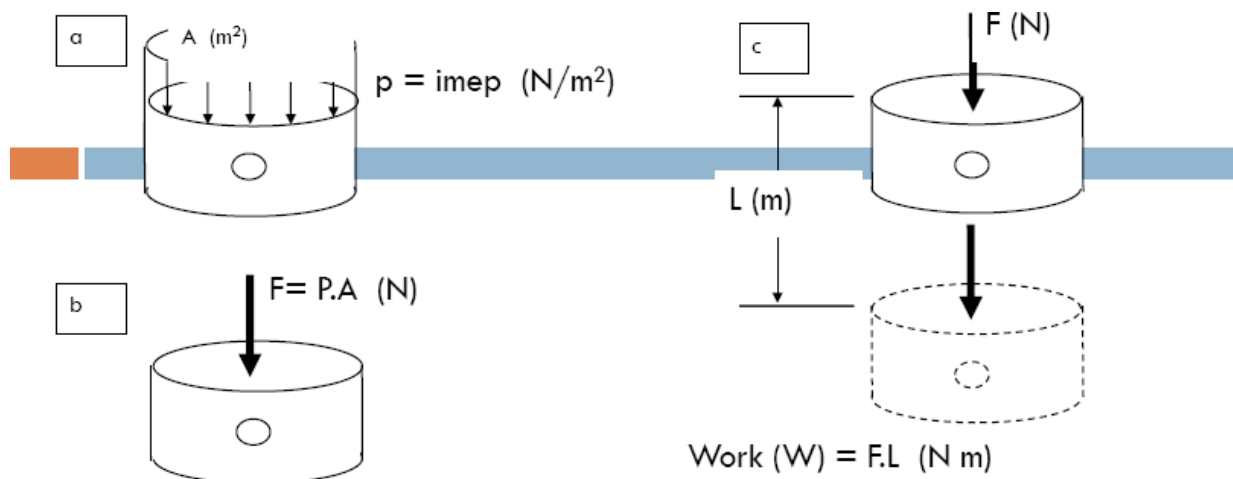
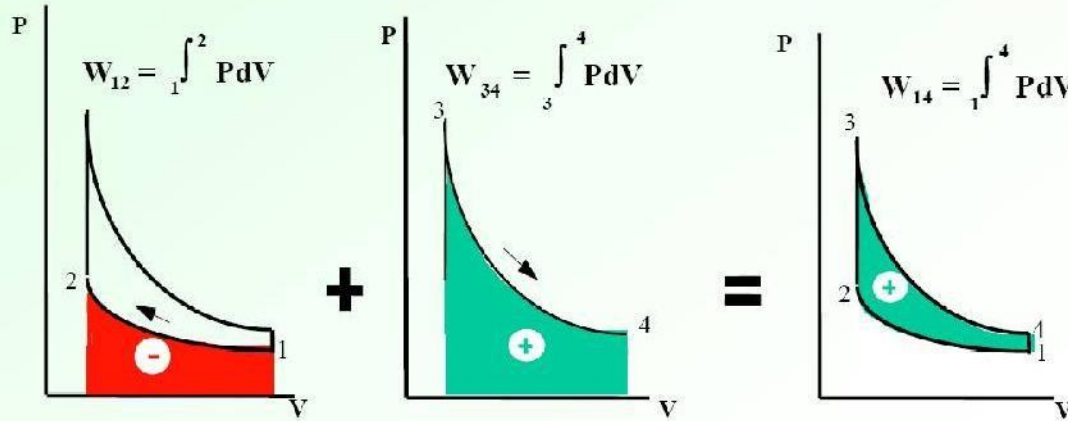

$$\text{Work (W)} = F.L \text{ (N m)}$$

$$\text{Time (t)} = 60 / (N_e / k) \text{ (s)}$$

$$\text{Indicated power } (P_i)_{\text{cylinder}} = W/t = F.L \cdot N_e / (k \cdot 60) \text{ (W)}$$

$$(P_i)_{\text{cylinder}} = (\text{imep} \cdot A \cdot L \cdot N) / (n_R \cdot 60)$$

$n_R = 2$ (four stroke)

$n_R = 1$ (two stroke)

$$(P_i)_{\text{engine}} = \text{imep} \cdot (A \cdot L \cdot n) / (n_R \cdot 60)$$

$n = \text{number of cylinder}$

$$(P_i)_{\text{engine}} = [\text{imep} \cdot V_e \cdot N_e / (n_R \cdot 60)] \text{ (W)}$$

AC
Go

Indicated, brake and frictional power

The indicated power per engine can also be given in terms of indicated work per cycle:

$$P_i = \frac{n \times W_i \times N}{n_R}$$

Where N—crankshaft speed in rev/s

n_R -number of crank revolutions per cycle

= 2 for 4-stroke

= 1 for 2-stroke

The term brake power, P_b , issued to specify that the power is measured at the out put shaft, this is the usable power delivered by the engine to the load.

Part of the gross indicated work per cycle or power is used to expel exhaust gases and induct fresh charge.

An additional portion is used to over come the friction of the bearings, pistons, and other mechanical components of the engine ,and to drive the engine accessories. The energy flow through the engine is expressed in 3 distinct terms Indicated Power, Brake Power, Friction Power.

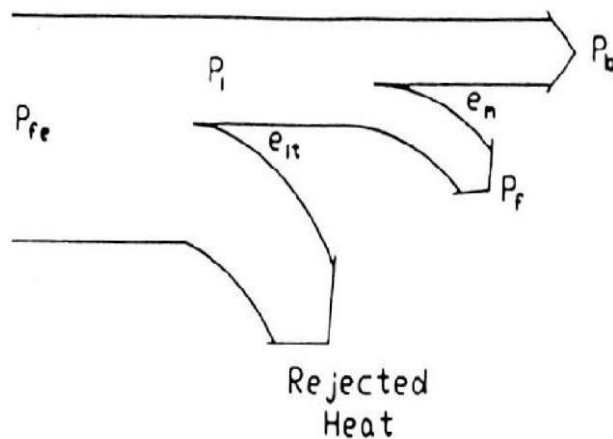

Mechanical Efficiency

The ratio of the brake (or use ful)power delivered by the engine to the indicated power is called the *mechanical efficiency*.

$$\eta_m = \frac{P_b}{P_{ig}} = 1 - \frac{P_f}{P_{ig}}$$

Mechanical efficiency depends on *throttle position* as well as *engine design* and *engine speed*.

Typical values for a modern automotive engine at wide open or full throttle are 90 percent at speeds

below about 30 to 40 rev/s (1800 to 2400 rev/min), decreasing to 75 percent at maximum rated speed.

Power Speed Curve

$$P_{ig} = P_b + P_f$$

Where:

P_{ig} = indicated power

P_b = brake power

P_f = friction power

$$\eta_m = \frac{P_b}{P_{ig}} = 1 - \frac{P_f}{P_{ig}}$$

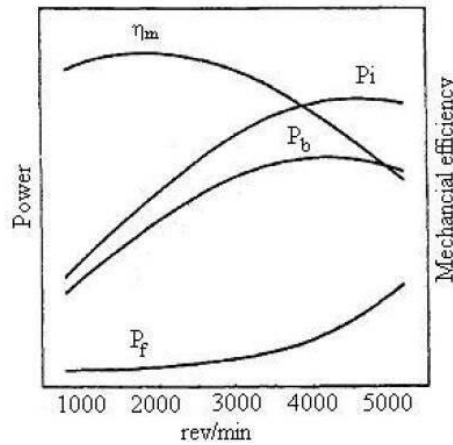

Mean effective pressure (m_{ep})

MEP is a fictitious pressure that, if acted on the piston during the entire power stroke, would produce the same amount of network as that produced during the actual cycle

Mean effective pressure (m_{ep}) is the work done per unit displacement volume. $m_{ep} = W/VD$

The net work during the intake and exhaust strokes is: $W_{p,net} = (P_i - P_e)$

The work per displacement volume required to pump the working fluid into and out of the engine during the intake and exhaust strokes is termed as the pump work (WP) and the mean effective pressure is called pump mean effective pressure (PMEP)

$$W_{p,net}/VD = p_{mep} = (P_i - P_e)$$

The indicated mean effective pressure (i_{mep}) is defined as the work per unit displacement volume done by the gas during the compression and expansion stroke.

$$i_{mep} = W_i/VD$$

The net indicated mean effective pressure for the whole cycle, $i_{mep,net} = i_{mep} - p_{mep}$

$$m_{ep} = W/VD$$

$$W_i = \frac{P \times n_R}{N}$$

$$m_{ep} = \frac{P \times n_R}{V_D \times N}$$

n_R is the number of crank revolutions for each power stroke per cylinder Indicated and brake Mean effective Pressure

- For SI unit

$$mep(N/m^2) = \frac{P(kW) \times n_R \times 6 \times 10^4}{V_D(m^3) \times N(rpm)}$$

- Mean effective pressure can also be expressed in terms of torque

$$P = \frac{2 \pi N(rpm) \times T(Nm)}{60} [W]$$

$$mep(N/m^2) = \frac{2 \pi T(Nm) \times n_R}{V_D(m^3)}$$

- Indicated power gives **indicated mean effective pressure**:

$$imep(N/m^2) = \frac{P_i(kW) \times n_R \times 6 \times 10^4}{V_D(m^3) \times N(rpm)}$$

Brake Mean effective Pressure

$$bmep(N/m^2) = \frac{P_b(kW) \times n_R \times 6 \times 10^4}{V_D(m^3) \times N(rpm)}$$

Engine Torque Te-Torque and crank shaft angle

Work is also accomplished when the torque is applied through an angle.

- Distance

$$xy = r\theta$$

$$W = F \cdot xy = Fr\theta = T\theta$$

$$W_{per\ revolution} = T(2\pi)$$

$$P = W/t = T(2\pi)/t = T\omega$$

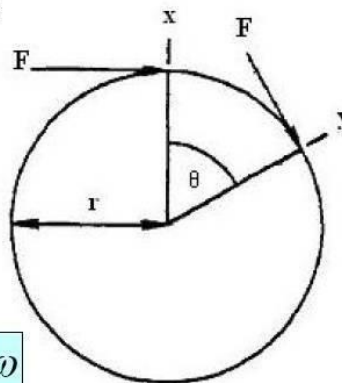

Where:

$$\omega = \frac{2 \pi N}{60}$$

Ac
Go

Engine Brake Torque Te

$$P_b = T_e \times \omega = \frac{2\pi N \times T_e}{60} = \frac{T_e(Nm) \times N(rpm)}{9550} (kW)$$

Brake mean effective pressure can also be expressed in terms of torque

$$bmep(N/m^2) = \frac{2\pi T_e(N.m) \times n_R}{V_D(m^3)}$$

$$T_e(N.m) = \frac{bmep(N/m^2) \times V_D(m^3)}{2\pi \times n_R}$$

Where:

N = Engine speed (rpm)

V_D = engine Displacement capacity (m³)

n_R = 2, for 4-stroke engines

1, for 2-stroke engines

Specific fuel consumption (sfc) is fuel flow rate per unit power output.

It measures how efficiently an engine is using the fuel supplied to produce work:

$$sfc = \frac{\dot{m}_f}{P}$$

$$sfc(mg/J) = \frac{\dot{m}_f(g/s)}{P(kW)}$$

$$sfc(g/kW.h) = \frac{\dot{m}_f(g/h)}{P(kW)}$$

- Brake power gives **brake specific fuel consumption:**

$$bsfc = \frac{\dot{m}_f}{P_b}$$

- Indicated power gives **indicated specific fuel consumption:**

$$isfc = \frac{\dot{m}_f}{P_i}$$

A
G

Brake Specific Fuel Consumption vs Engine Size

Brake specific fuel consumption generally decreases with engine size, being best (lowest) for very large engines. One reason for this is less heat loss due to the higher volume to surface area ratio of the combustion chamber in large engines. Also large engines operate at lower speeds which reduce friction losses.

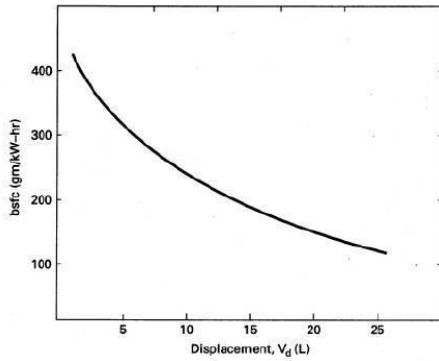

Brake specific fuel consumption decreases as engine speed increases, reaches a minimum, and then increases at high speeds. Fuel consumption increases at high speeds because of greater friction losses. At low engine speed, the longer time per cycle allows more heat loss and fuel consumption goes up.

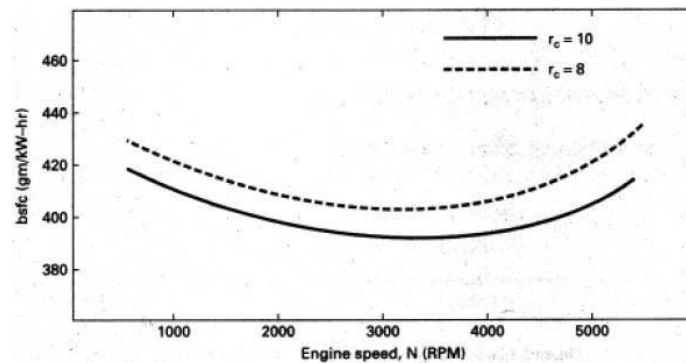

Engine Thermal Efficiencies

The time for combustion in the cylinder is very short so not all the fuel may be consumed or local temperatures may not favor combustion. A small fraction of the fuel may not react and exits with the exhaust gas. The combustion efficiency is defined as:

$$\eta_c = \frac{\text{actual heat input}}{\text{theoretical heat input}} = \frac{Q_{in}}{m_f Q_{HV}}$$

Where Q_{in} = heat added by combustion per cycle

m_f = mass of fuel added to cylinder per cycle

Q_{HV} = heating value of the fuel (chemical energy per unit mass)

Indicated thermal efficiency (η_{ith})

Is the ratio of energy in the indicated power, P_i , to the input fuel energy in appropriate units

$$\eta_{ith} = \frac{P_i}{\text{rate of heat input per cycle}} = \frac{P_i}{\dot{Q}_{in}} = \frac{P_i}{\dot{m}_f Q_{HV} \eta_C}$$

Indicated thermal efficiencies are typically 50% to 60% and brake thermal efficiencies are usually about 30%

Brake Thermal Efficiency (η_{bth})

Is the ratio of energy in the brake power P_b to the input fuel energy in appropriate units

$$\eta_{bth} = \frac{P_b}{\text{rate of heat input per cycle}} = \frac{P_b}{\dot{Q}_{in}} = \frac{P_b}{\dot{m}_f Q_{HV} \eta_C}$$

Volumetric efficiency CI (η_v)

The volumetric efficiency is used to measure the effectiveness of an engine's induction process.

Volumetric efficiency is usually used with four stroke cycle engines which have a distinct induction process.

It is defined as the volume flowrate of air into the intake system divided by the rate at which volume is displaced by the piston:

$$\eta_v = \frac{m_a}{\rho_{a,i} V_D} = \frac{2 \dot{m}_a}{\rho_{a,i} V_D N} \quad \left| \quad \dot{V}_d = V_d \frac{N}{2} \right.$$

Where: m_a is the mass of air inducted into the cylinder per cycle.

Volumetric Efficiency SI (η_v)

Where number of intake strokes per minutes

$$\eta_v = \frac{2(\dot{m}_a + \dot{m}_f)}{\rho_{a,i} V_d N}$$

$n=N/2$ for 4-S Engines $n= N$ for 2-S Engines

N = speed of engine in rpm

Typical values of volumetric efficiency for an engine at wide open throttle (WOT) are in the range 75% to 90%, going down to much lower values as the throttle is closed.

MODULE- III B AIR COMPRESSOR

Syllabus:

Classification and working principle of various types of compressors, work of compression with and without clearance, Volumetric efficiency, Isothermal efficiency and Isentropic efficiency of reciprocating compressors, Multistage air compressor and inter cooling – work of multistage air compressor.

Classification of compressors:

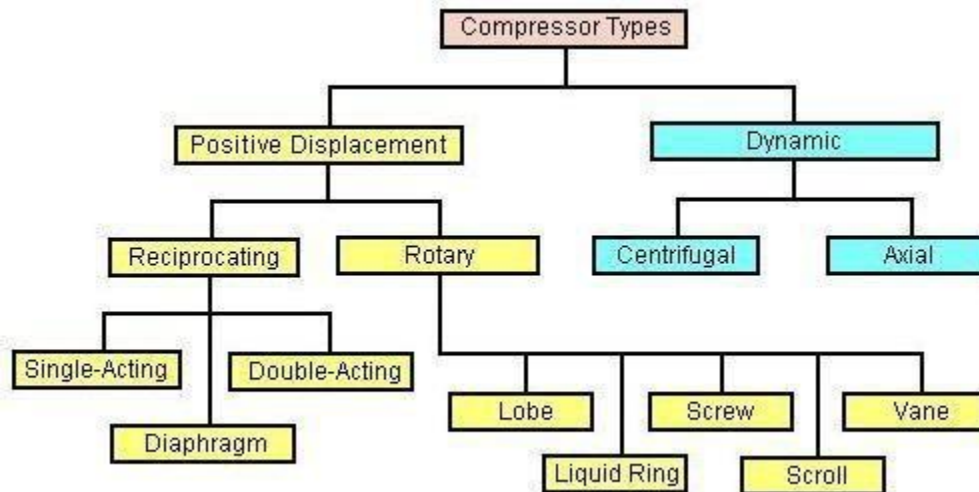

The compressors are also classified based on other aspects like

1. Number of stages (single-stage, 2-stage and multi-stage),
2. Cooling method and medium (Air cooled, water cooled and oil-cooled),
3. Drive types (Engine driven, Motor driven, Turbine driven, Belt, chain, gear or direct coupling drives),
4. Lubrication method (Splash lubricated or forced lubrication or oil-free compressors).
5. Service Pressure (Low, Medium, High)

Positive Displacement compressors:

Reciprocating Compressor:

Single-Acting Reciprocating compressor:

These are usually reciprocating compressors, which has piston working on air only in one direction. The other end of the piston is often free or open which does not perform any work. The air is compressed only on the top part of the piston. The bottom of the piston is open to crankcase and not utilized for the compression of air.

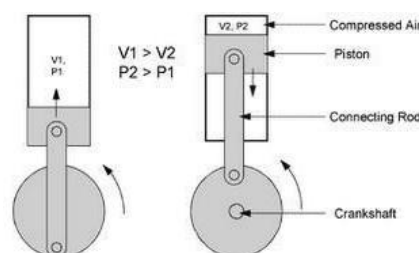

Double acting compressor:

These compressors are having two sets of suction/intake and delivery valves on both sides of the piston. As the piston moves up and down, both sides of the piston is utilized in compressing the air. The intake and delivery valves operate corresponding to the stroke of the compressor. The compressed air delivery is comparatively continuous when compared to a single-acting air compressor. Thus both sides of the pistons are effectively used in compressing the air.

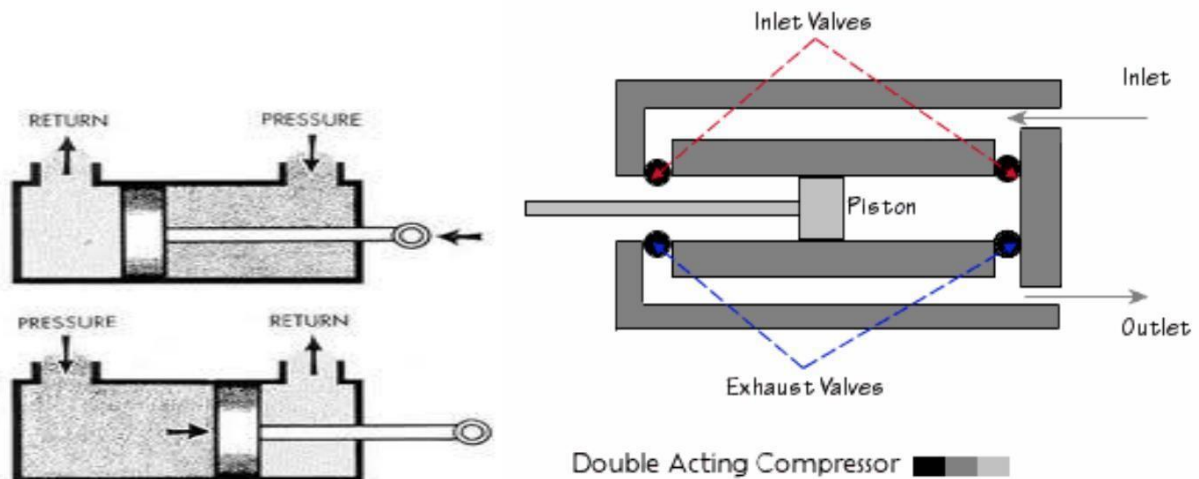

Diaphragm Compressors:

In the diaphragm compressor, the piston pushes against a diaphragm, so the air does not come in contact with the reciprocating parts. This type compressor is preferred for food preparation, pharmaceutical, and chemical industries, because no effluent from the compressor enters the fluid.

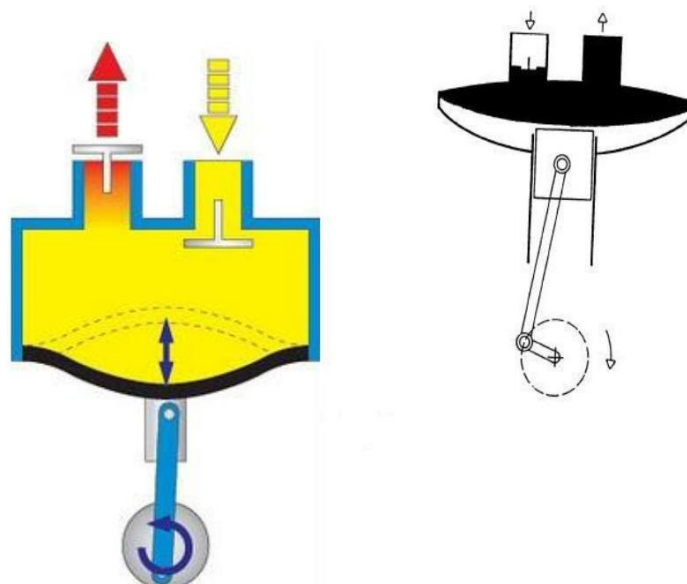

Rotary compressors:

Lobe compressor:

The Lobe type air compressor is very simpler type with no complicated moving parts. There are single or twin lobes attached to the drive shaft driven by the prime mover. The lobes are displaced by 90 degrees. Thus if one of the lobes is in horizontal position, the other at that particular instant will be in vertical position. Thus the air gets trapped in between these lobes and as they rotate they get compressed and delivered to the delivery line.

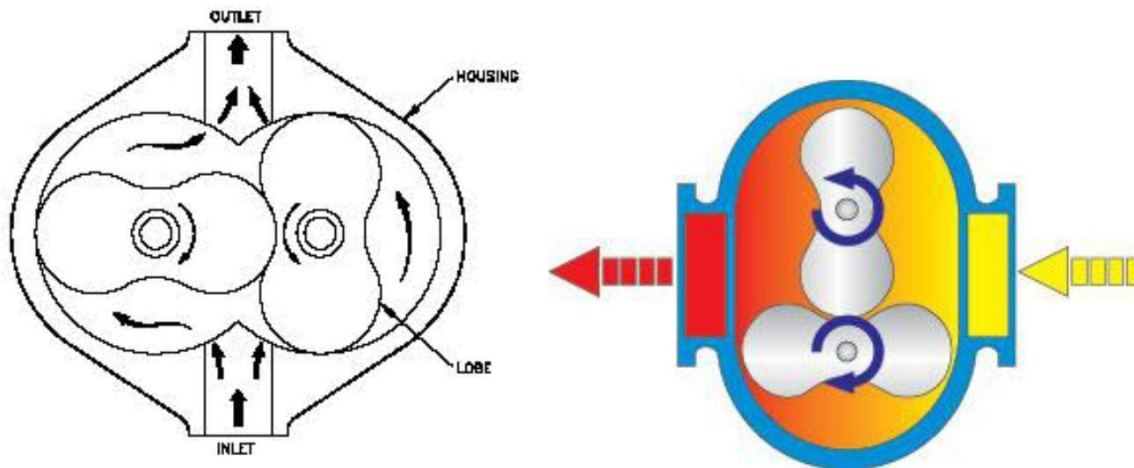

Liquid ring compressor:

Liquid ring compressors require a liquid to create a seal. For medical applications, liquid ring compressors are always sealed with water but not oil. An impeller, which is offset so the impeller is not in the center of the pump housing, rotates and traps pockets of air in the space between the impeller fins and the compressor housing. The impeller is typically made of brass. As the impeller turns, there is a pocket of air that is trapped in the space between each of the fins. The trapped air is compressed between the impeller and the pump housing, sealed with the waterring. As the air is compressed, it is then pushed out of the pumps discharge. To avoid possible contaminants the compressor is always getting a supply of fresh sealing water.

In a “once through” system, sealing water is drained and used only once, while in a “partial re-circulating” system, some (but never all) of the discharged water is re-circulated.

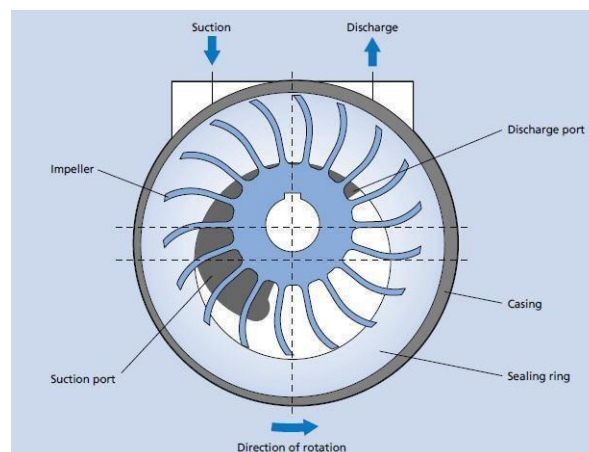

Vane Type compressor:

The rotary slide vane-type, as illustrated in Figure, has longitudinal vanes, sliding radially in a slotted rotor mounted eccentrically in a cylinder. The centrifugal force carries the sliding vanes against the cylindrical case with the vanes forming a number of individual longitudinal cells in the eccentric annulus between the case and rotor. The suction port is located where the longitudinal cells are largest. The size of each cell is reduced by the eccentricity of the rotor as the vanes approach the discharge port, thus compressing the air.

This type of compressor, looks and functions like a vane type hydraulic pump. An eccentrically mounted rotor turns in a cylindrical housing having an inlet and outlet. Vanes slide back and forth in grooves in the rotor. Air pressure or spring force keeps the tip of these vanes in contact with the housing. Air is trapped in the compartments formed by the vanes and housing and is compressed as the rotor turns.

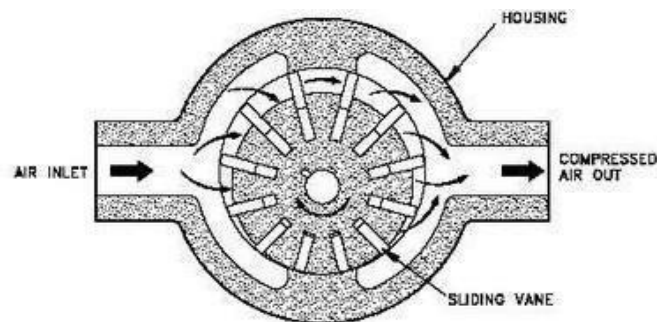

Screw Type compressor:

The screw compressors are efficient in low air pressure requirements. Two screws rotate intermeshing with each other, thus trapping air between the screws and the compressor casing, forming pockets which progressively travel and gets squeezed and delivering it at a higher pressure which opens the delivery valve. The compressed air delivery is continuous and quiet in operation than a reciprocating compressor.

Rotary air compressors are positive displacement compressors. The most common rotary air compressor is the single stage helical or spiral lobe oil flooded screw air compressor. These compressors consist of two rotors within a casing where the rotors compress the air internally. There are no valves. These units are basically oil cooled (with air cooled or water cooled oil coolers) where the oil seals the internal clearances.

Since the cooling takes place right inside the compressor, the working parts never experience extreme operating temperatures. The rotary compressor, therefore, is a continuous duty, air cooled or water cooled compressor package.

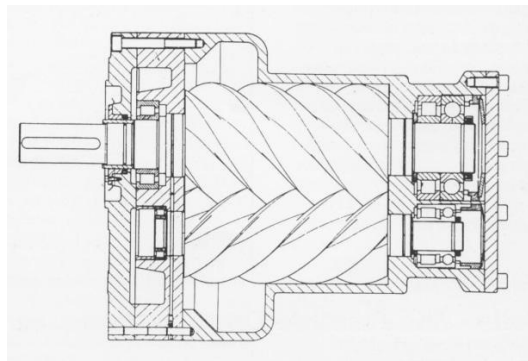

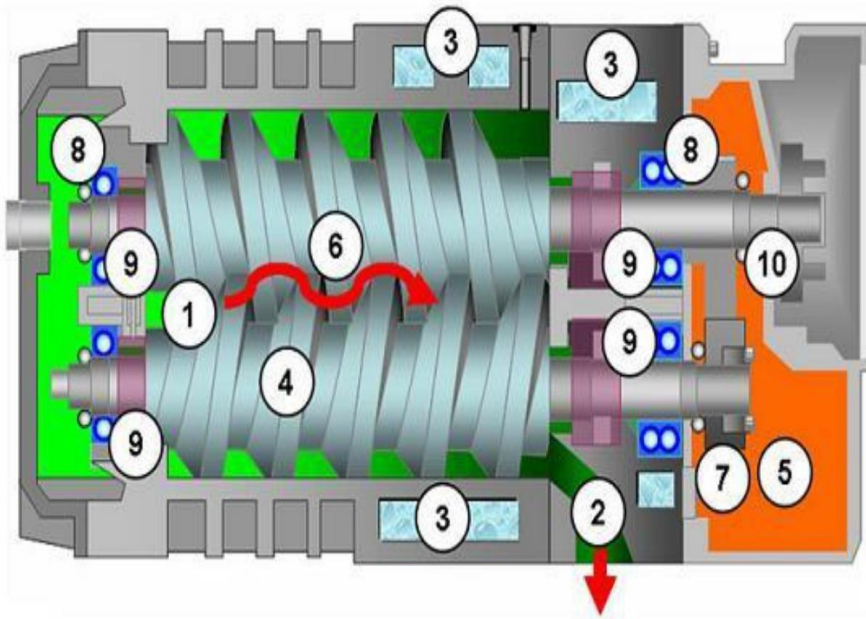

1	Inlet	6	Gas Path
2	Exhaust	7	Timing Gears
3	Water Jacket	8	Bearings
4	Screw	9	Shaft Seal
5	Oil	10	Oil Seal

Scroll Type Compressor:

This type of compressor has a very unique design. There are two scrolls that look like loosely rolled up pieces of paper—one rolled inside the other. The orbiting scroll rotates inside of the stationary scroll. The air is forced into progressively smaller chambers towards the center. The compressed air is then discharged through the center of the fixed scroll. No inlet or exhaust valves are needed.

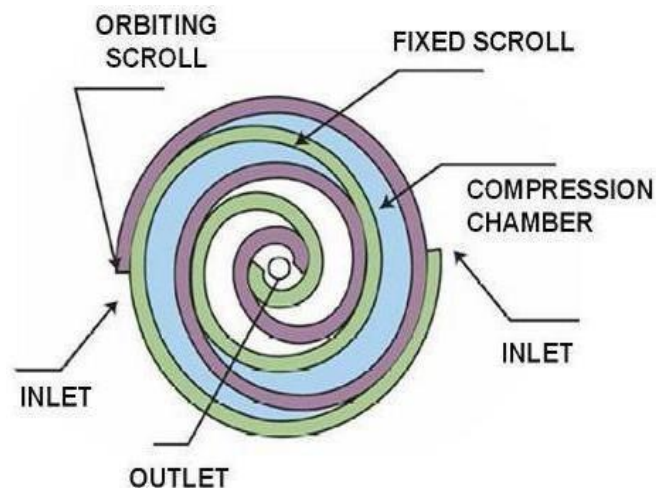

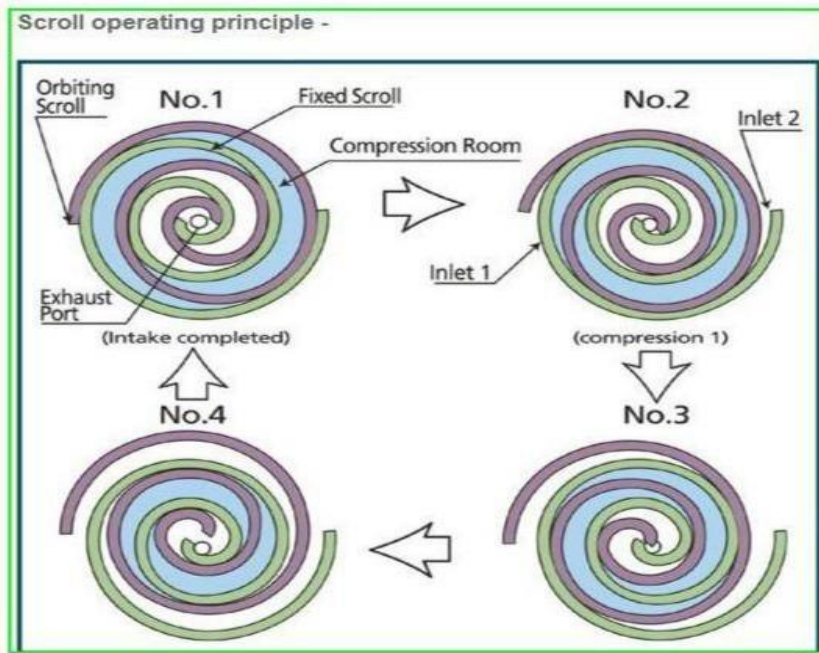

Non-Positive displacement compressors or Dynamic compressor

MODULE -IV

Rotary and Centrifugal Compressor

The centrifugal air compressor is a **dynamic** compressor which depends on transfer of energy from a **rotating impeller** to the air.

Centrifugal compressors produce high-pressure discharge by converting angular momentum imparted by the rotating impeller (dynamic displacement). In order to do this efficiently, centrifugal compressors rotate at higher speeds than the other types of compressors. These types of compressors are also designed for higher capacity because flow through the compressor is continuous. Adjusting the inlet guide vanes is the most common method to control capacity of a centrifugal compressor. By closing the guide vanes, volumetric flows and capacity are reduced. The centrifugal air compressor is an oil free compressor by design. The oil lubricated running gear is separated from the air by shaft seals and atmospheric vents.

The centrifugal air compressor is a dynamic compressor which depends on a rotating impeller to compress the air. In order to do this efficiently, centrifugal compressors must rotate at higher speeds than the other types of compressors. These types of compressors are designed for higher capacity because flow through the compressor is continuous and oil free by design.

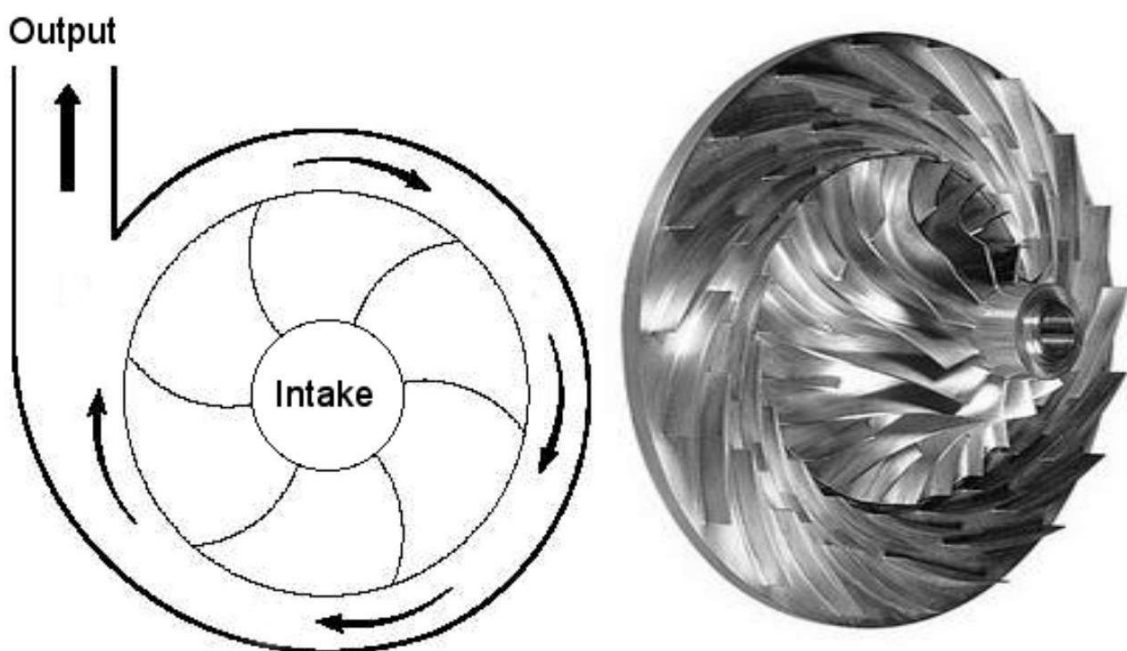

Axial Compressor:

These are similar to centrifugal compressors except the direction of air flow is axial. The blades of the compressor are mounted onto the hub and in turn onto the shaft. As the shaft rotates at a high speed, the ambient air is sucked into the compressor and then gets compressed (high speed of rotation of the blades impart energy to the air) and directed axially for further usage. An

axial flow compressor, in its very simple form is called as axial flow fan, which is commonly used for domestic purposes. The pressure built depends on the number of stages. These are commonly used as vent fans in enclosed spaces, blower ducts, etc. One can find its main application in the aerospace industry, where the gas turbines drive the axial flow air compressors.

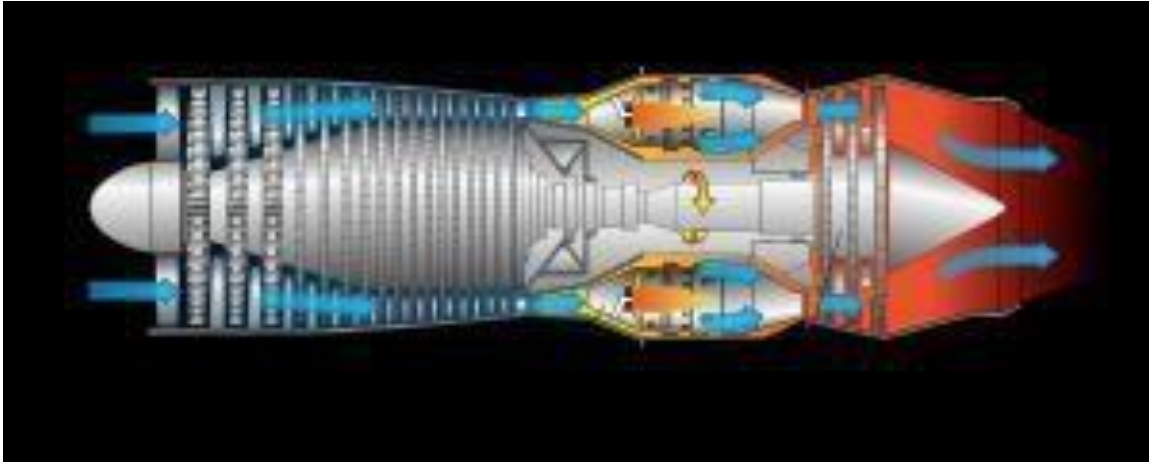

Roots Blower Compressor:

This type is generally called as blower. The discharge air pressure obtained from this type of machine is very low. The Discharge Pressure of 1 bar can be obtained in Single Stage and pressure of 2.2 bar is obtained from Stage. The discharge pressure achieved by two rotors which have separate parallel axis and rotate in opposite directions. This is the example of Positive Displacement Compressor in Rotary Type Air Compressor.

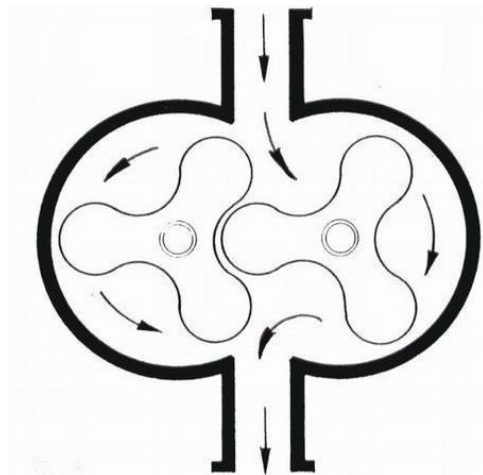

Multistage Compression:

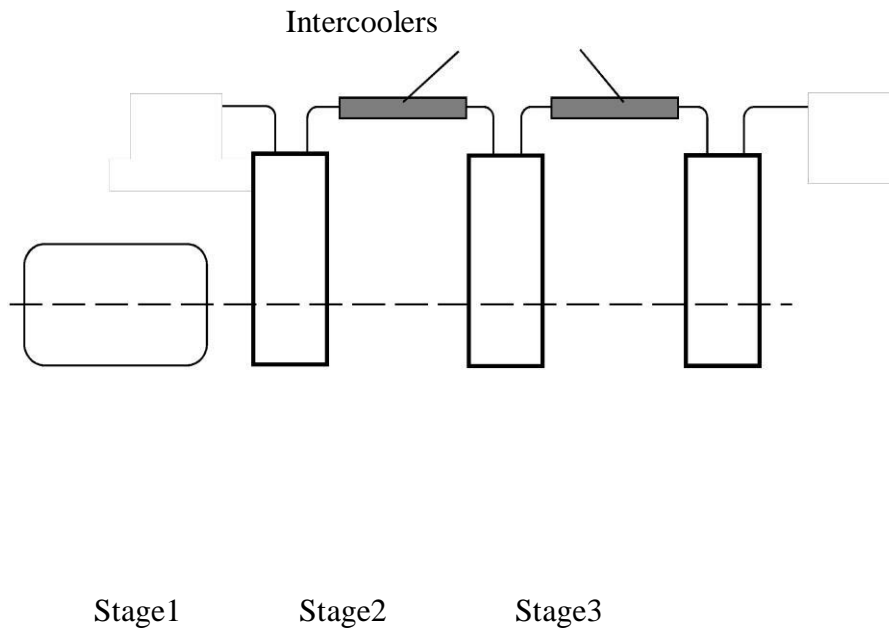

Multistage compression refers to the compression process completed in more than one stage i.e., a part of compression occurs in one cylinder and subsequently compressed air is sent to subsequent cylinders for further compression. In case it is desired to increase the compression ratio of compressor then multi-stage compression becomes inevitable. If we look at the expression for volumetric efficiency then it shows that the volumetric efficiency decreases with increase in pressure ratio. This aspect can also be explained using p-V representation shown in Figure.

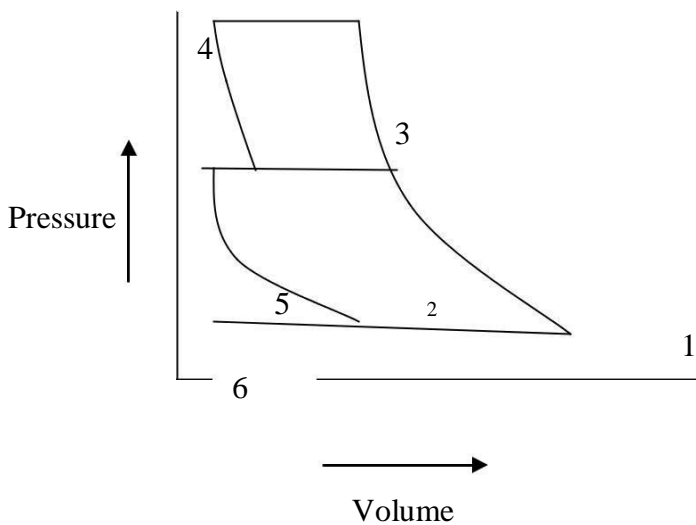

A multi-stage compressor is one in which there are several cylinders of different diameters. The intake of air in the first stage gets compressed and then it is passed over a cooler to achieve a temperature very close to ambient air. This cooled air is passed to the intermediate stage where it is again getting compressed and heated. This air is again passed over a cooler to achieve a temperature as close to ambient as possible. Then this compressed air is passed to the final or the third stage of the air compressor where it is compressed to the required pressure and delivered to the air receiver after cooling sufficiently in an after-cooler.

Advantages of Multi-stage compression:

1. The work done in compressing the air is reduced, thus power can be saved
2. Prevents mechanical problems as the air temperature is controlled
3. The suction and delivery valves remain in cleaner condition as the temperature and vaporization of lubricating oil is less
4. The machine is smaller and better balanced
5. Effects from moisture can be handled better, by draining at each stage
6. Compression approaches near isothermal
7. Compression ratio at each stage is lower when compared to a single-stage machine
8. Light moving parts usually made of aluminum, thus less cost and better maintenance

Work done in a single stage reciprocating compressor without clearance volume:

9.

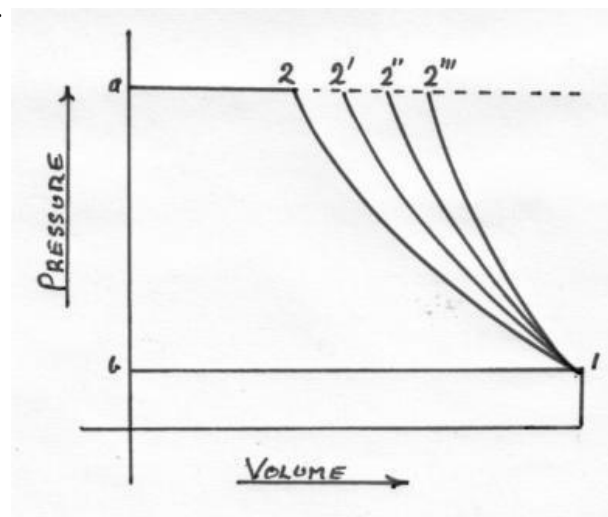

Air enters compressor at pressure p_1 and is compressed upto p_2 . Compression work requirement can be estimated from the area below the each compression process. Area on p-V diagram shows that work requirement shall be minimum with isothermal process 1-2''. Work requirement is maximum with process 1-2ie., adiabatic process. As a designer one shall be interested in a

compressor having minimum compression work requirement. Therefore, ideally compression should occur isothermally for minimum work input. In practice it is not possible to have isothermal compression because constancy of temperature during compression cannot be realized. Generally, compressors run at substantially high speed while isothermal compression requires compressor to run at very slow speed so that heat evolved during compression is dissipated out and temperature remains constant. Actually due to high speed running of compressor the compression process may be assumed to be near adiabatic or polytropic process following law of compression as $Pv^n=C$ with of „n“ varying between 1.25 to 1.35 for air. Compression process following three processes is also shown on T-s diagram in Fig.16.4. it is thus obvious that actual compression process should be compared with isothermal compression process. A mathematical parameter called isothermal efficiency is defined for quantifying the degree of deviation of actual compression process from ideal compression process. Isothermal efficiency is defined by the ratio is isothermal work and actual indicated work in reciprocating compressor.

$$\text{Isothermal efficiency} = \frac{\text{Isothermal work}}{\text{Actual indicated Work}}$$

Practically, compression process is attempted to be closed to isothermal process by air/water cooling, spraying cold water during compression process. In case of multistage compression process the compression in different stages is accompanied by intercooling in between the stages. $P_2 V_2$.

Mathematically, for the compression work following polytropic process, $PV^n=C$. Assuming negligible clearance volume the cycle work done.

Volumetric Efficiency:

Volumetric efficiency of compressor is the measure of the deviation from volume handling capacity of compressor. Mathematically, the volumetric efficiency is given by the ratio of actual volume of air sucked and swept volume of cylinder. Ideally the volume of air sucked should be equal to the swept volume of cylinder, but it is not so in actual case. Practically the volumetric efficiency lies between 60 to 90%.

Volumetric efficiency can be overall volumetric efficiency and absolute volumetric efficiency as given below.

$$\text{Overall volumetric efficiency} = \frac{\text{Volume of free air sucked in cylinder}}{\text{Swept volume of LP cylinder}}$$

$$(\text{Volumetric efficiency})_{\text{Free air Condition}} = \frac{\text{Volume of free air sucked in cylinder}}{(\text{Swept volume of LP cylinder})_{\text{free air condition}}}$$

Here free air condition refers to the standard conditions. Free air condition may be taken as 1 atm or 1.01325 bar and 15°C or 288K. Consideration for free air is necessary as otherwise the different compressors cannot be compared using volumetric efficiency because specific volume or density of air varies with altitude. It may be seen that a compressor at datum level (sea level) shall deliver large mass than the same compressor at high altitude.

MODULE- V

REFRIGERATION AND AIRCONDITIONING

Syllabus:

Vapour compression refrigeration cycle- super heat, sub cooling – Performance calculations - working principle of vapour absorption system, Ammonia –Water, Lithium bromide –water systems (Description only) - Alternate refrigerants – Comparison between vapour compression and absorption systems – Air conditioning system: Types, Working Principles - Psychrometry, Psychrometric chart - Cooling Load calculations - Concept of RSHF, GSHP, ESHF.

Vapour Compression Refrigeration Cycle:

Process 1-2: Isentropic compression of the refrigerant from state 1 to state 2. During this process work is done on the refrigerant by the surroundings. At the end of the process the refrigerant will be in superheated vapour state.

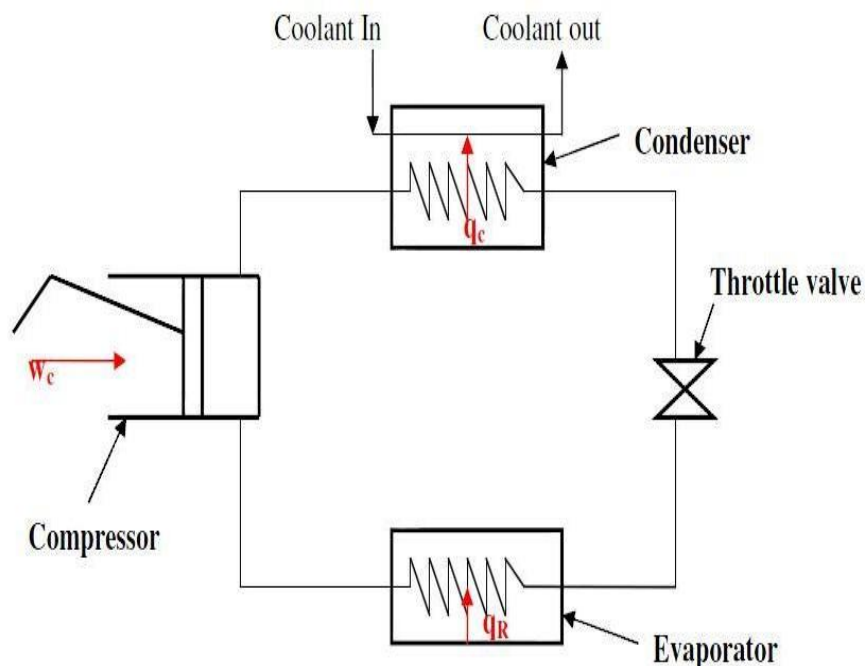

Process 2-3: Constant pressure condensation of the refrigerant in the condenser till it becomes a saturated liquid.

Process 3-4: Throttling expansion of the refrigerant from condenser pressure to the evaporator pressure.

Process 4-1: Constant pressure vaporization of the refrigerant in the evaporator till it becomes a dry saturated vapour. During this process heat is absorbed by the refrigerant from the place to be refrigerated.

Applying steady flow steady state energy equation to the evaporator and neglecting

the changes in kinetic and potential energies we have

$$\text{Refrigeration effect} = Q_R = m (h_1 - h_4)$$

Since process 3-4 is a throttling process, $h_4 = h_3$.

$$\text{Hence } Q_R = m (h_1 - h_3)$$

Similarly, by applying steady flow, steady state energy equation to compressor we get

$$\text{Compressor work input} = W_c = m (h_2 - h_1)$$

Hence
$$\text{COP} = \frac{Q_R}{W_c} = \frac{(h_1 - h_4)}{(h_2 - h_1)}$$

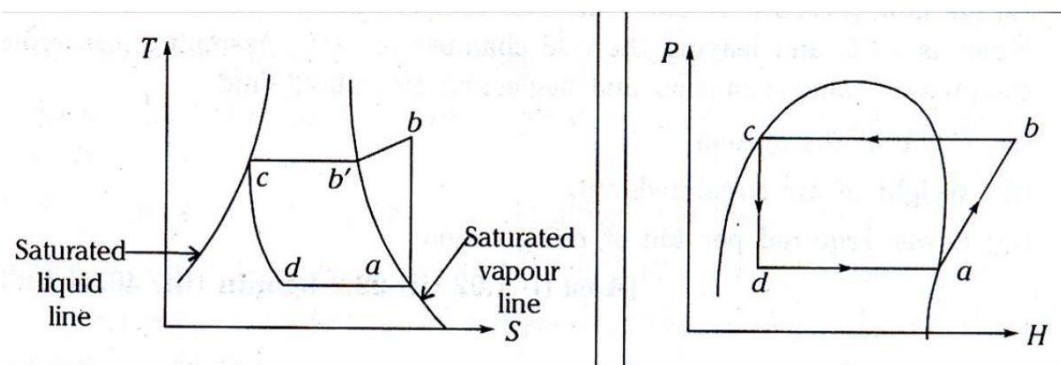

Sub cooling or under cooling:

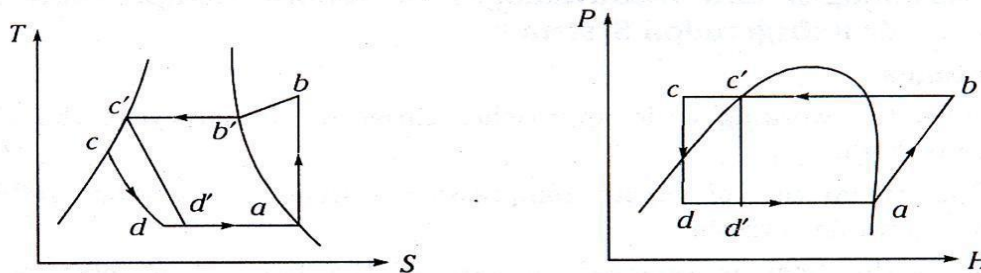

Super Heating:

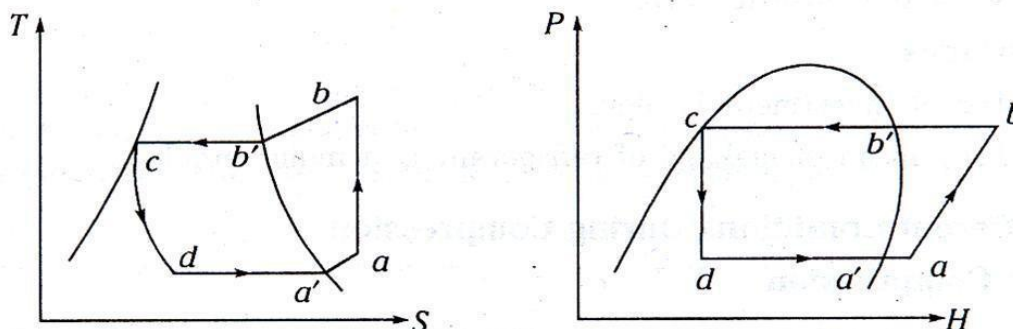

Advantages of Vapour compression refrigeration system over air refrigeration system:

- Since the working cycle approaches closer to Carnot cycle, the C.O.P is quite high.
- Operational cost of vapour compression system is just above 1/4th of air refrigeration system.
- Since the heat removed consists of the latent heat of vapour, the amount of liquid circulated is less and as a result the size of the evaporator is smaller.
- Any desired temperature of the evaporator can be achieved just by adjusting the throttle valve.

Disadvantages of Vapour compression refrigeration system over air refrigeration system

- Initial investment is high
- Prevention of leakage of refrigerant is a major problem

Refrigerant

A refrigerant is a fluid in a refrigerating system that by its evaporating takes the heat of the cooling coils and gives up heat by condensing the condenser.

Identifying refrigerants by numbers

The present practice in the refrigeration industry is to identify refrigerants by numbers. The identification system of numbering has been standardized by the American Society of Heating, Refrigerating and Air Conditioning Engineers (ASHRAE), some refrigerants in common use are

<i>Refrigeration</i>	<i>Name and Chemical Formula</i>
R-11	Trichloromonofluoromethane CCl_3F
R-12	Dichlorodifluoromethane CCl_2F_2
R-22	Monochlorodifluoromethane CHClF_2
R-717	Ammonia NH_3
R114(R40)	Azeotropic mixture of 73.8%
R-500	(R-22) and 26.2% R-152a
R502	Azeotropic mixture of 48.8%
	(R-22) and 51.2% R-115
R-764	Sulphur Dioxide SO_2

Properties of Refrigerants

- **Toxicity:**
It is obviously desirable that the refrigerant have little effect on people

- **Inflammability:**
Although refrigerants are entirely sealed from the atmosphere, leaks are bound to develop. If the refrigerant is inflammable and the system is located where ignition of the refrigerant may occur, a great hazard is involved.
- **Boiling Point.**
An ideal refrigerant must have low boiling temperature at atmospheric pressure
- **Freezing Point**
An ideal refrigerant must have a very low freezing point because the refrigerant should not freeze at low evaporator temperatures.
- **Evaporator and condenser pressure.**
In order to avoid the leakage of the atmosphere air and also to enable the detection of the leakage of the refrigerant, both the Evaporator and condenser pressure should be slightly above the atmosphere pressure.
- **Chemical Stability**
An ideal refrigerant must not decompose under operating conditions..
- **Latent heat of Evaporation.**
The Latent heat of Evaporation must be very high so that a minimum amount of refrigerant will accomplish the desired result; in other words, it increases the refrigeration effect
- **Specific Volume**
The Specific Volume of the refrigerant must be low. The lower specific volume of the refrigerant at the compressor reduces the size of the compressor.
- **Specific heat of liquid vapour.**
A good refrigerant must have low specific heat when it is in liquid state and high specific heat when it is vaporized
- **Viscosity**
The viscosity of the refrigerant t both the liquid and vapour state must be very low as improved the heat transfer and reduces the pumping pressure.
- **Corrosiveness.**
A good refrigerant should be non-corrosive to prevent the corrosion of the metallic parts of the refrigerator.
- **Odour.**
A good refrigerant must be odourless, otherwise some foodstuff such as meat, butter, etc. loses their taste
- **Oil solvent properties.**
A good refrigerant must be not react with the lubricating oil used in the refrigerator for

lubricating the parts of the compressor.

Ton of refrigeration:

Amount of heat required to Melt a Ton of Ice in a 24/h Period

One ton of refrigeration is the heat required to melt 1 ton of ice in 24 hrs. That is, a refrigeration machine rated at 1 ton cools as much in 24 hrs. as 1 ton of ice would by melting in the same period.

The heat required is the product of the latent heat of fusion and the mass in kg.

$$Q = mH,$$

$$1 \text{ ton} = 907 \text{ kg}$$

$$\text{latent heat of fusion: } H = 340 \text{ kJ/kg}$$

$$Q = 907 * 340 = 308380 \text{ kJ}$$

The power required is then:

$$P = E/t = Q/t = 308380 \text{ kJ}/24 \text{ hr} = 308380/(24*3600) = 3.57 \text{ kw}$$

Note: 1 watt = 1 J/s

so that 1 kw = 1 kJ/s

Ammonia Water vapour absorption refrigeration system:

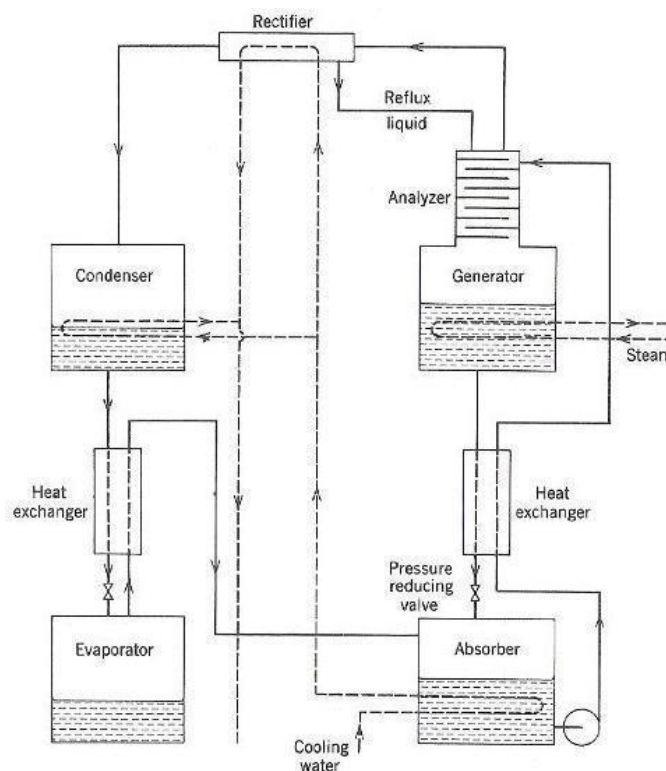

1) Evaporator: It is in the evaporator where the refrigerant pure ammonia (NH_3) in liquid state produces the cooling effect. It absorbs the heat from the substance to be cooled and gets evaporated. From here, the ammonia passes to the absorber in the gaseous state.

2) Absorber: In the absorber the weak solution of ammonia-water is already present. The water, used as the absorbent in the solution, is unsaturated and it has the capacity to absorb more ammonia gas. As the ammonia from evaporator enters the absorber, it is readily absorbed by water and the strong solution of ammonia-water is formed. During the process of absorption heat is liberated which can reduce the ammonia absorption capacity of water; hence the absorber is cooled by the cooling water. Due to absorption of ammonia, strong solution of ammonia-water is formed in the absorber.

3) Pump: The strong solution of ammonia and water is pumped by the pump at high pressure to the generator.

4) Generator: The strong solution of ammonia refrigerant and water absorbent are heated by the external source of heat such as steam or hot water. It can also be heated by other sources like natural gas, electric heater, waste exhaust heat etc. Due to heating the refrigerant ammonia gets vaporized and it leaves the generator. However, since water has strong affinity for ammonia and its vaporization point is quite low some water particles also get carried away with ammonia refrigerant, so it is important to pass this refrigerant through an analyzer.

5) Analyzer: One of the major disadvantages of the ammonia-water vapor absorption refrigeration system is that the water in the solution has quite low vaporizing temperature, hence when ammonia refrigerant gets vaporized in the generator some water also gets vaporized. Thus the ammonia refrigerant leaving the generator carries appreciable amount of water vapor. If this water vapor is allowed to be carried to the evaporator, the capacity of the refrigeration system would reduce. The water vapor from ammonia refrigerant is removed by analyzer and the rectifier.

The analyzer is a sort of the distillation column that is located at the top of the generator. The analyzer consists of number of plates positioned horizontally. When the ammonia refrigerant along with the water vapor particles enters the analyzer, the solution is cooled. Since water has higher saturation temperature, water vapor gets condensed into the water particles that drip down into the generator. The ammonia refrigerant in the gaseous state continues to rise up and it moves to the rectifier.

6) Rectifier or the reflex condenser: The rectifier is a sort of the heat exchanger cooled by the water, which is also used for cooling the condenser. Due to cooling the remaining water vapor mixed with the ammonia refrigerant also gets condensed along with some particles of ammonia. This weak solution of water and ammonia drains down to the analyzer and then to the generator.

7) Condenser and expansion valve: The pure ammonia refrigerant in the vapor state and at high pressure then enters the condenser where it is cooled by water. The refrigerant ammonia gets converted into the liquid state and it then passes through the expansion valve where its temperature and pressure falls down suddenly. Ammonia refrigerant finally enters the evaporator, where it produces the cooling effect. This cycle keeps on repeating continuously.

Meanwhile, when ammonia gets vaporized in the generator, weak solution of ammonia and water is left in it. This solution is expanded in the expansion valve and passed back to the absorber and its cycle repeats.

Lithium Bromide-Water vapour absorption refrigeration system:

This refrigeration system is used for large tonnage capacity. In this system, lithium-bromide is acting as the absorbent and water is acting as refrigerant. Thus in the absorber the lithium bromide absorbent absorbs the water refrigerant and solution of water and lithium bromide is formed. This solution is pumped by the pump to the generator where the solution is heated. The water refrigerant gets vaporized and moves to the condenser where it is heated while lithium bromide flows back to the absorber where it further absorbs water coming from the evaporator.

The water-lithium bromide vapor absorption system is used in a number of air conditioning applications. This system is useful for the applications where the temperature required is more than 32 degree F.

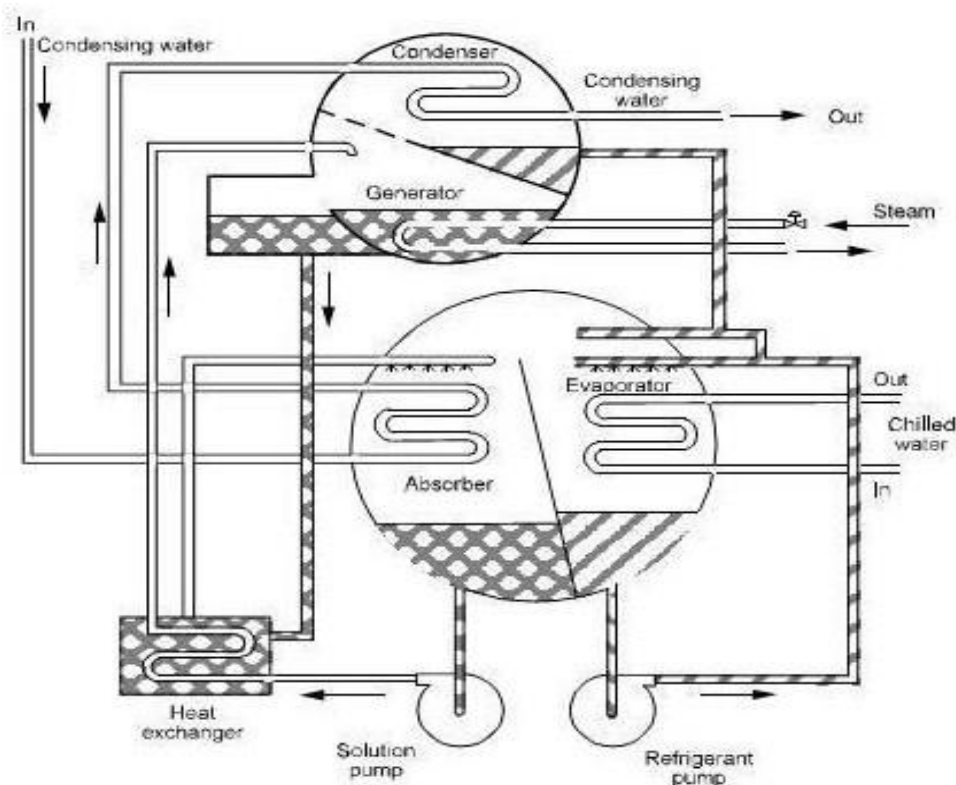

Special Features of Water-Lithium Bromide Solution

Here are some special features of the water and lithium bromide in absorption refrigeration system:

1) As such lithium bromide has great affinity for water vapor, however, when the water-lithium bromide solution is formed, they are not completely soluble with each other under all the operating conditions of the absorption refrigeration system. Hence, when the water-lithium bromide absorption refrigeration system is being designed, the designer must take care that such conditions would not be created where the crystallization and precipitation of lithium bromide would occur.

2) The water used as the refrigerant in the absorption refrigeration system means the operating pressures in the condenser and the evaporator would be very low. Even the difference of pressure between the condenser and the evaporator are very low, and this can be achieved even without installing the expansion valve in the system, since the drop in pressure occurs due to friction in the refrigeration piping and also in the spray nozzles.

3) The capacity of any absorption refrigeration system depends on the ability of the absorbent to absorb the refrigerant, which in turn depends on the concentration of the absorbent. To increase the capacity of the system, the concentration of absorbent should be increased, which would enable absorption of more refrigerant. Some of the most common methods used to change the concentration of the absorbent are: controlling the flow of the steam or hot water to the generator, controlling the flow of water used for condensing in the condenser, and re-concentrating the absorbent leaving the generator and entering the absorber.

Parts of the Water-Lithium Bromide Absorption Refrigeration and their Working

Let us see various parts of the water-lithium bromide absorption refrigeration and their working (please refer the figure above):

1) Evaporator: Water as the refrigerant enters the evaporator at very low pressure and temperature. Since very low pressure is maintained inside the evaporator the water exists in the partial liquid state and partial vapor state. This water refrigerant absorbs the heat from the substance to be chilled and gets fully evaporated. It then enters the absorber.

2) Absorber: In the absorber concentrated solution of lithium bromide is already available. Since water is highly soluble in lithium bromide, solution of water-lithium bromide is formed. This solution is pumped by the pump to the generator.

3) Generator: The heat is supplied to the refrigerant water and absorbent lithium bromide solution in the generator from the steam or hot water. Due to heating water gets vaporized and it moves to the condenser, where it gets cooled. As water refrigerant moves further in the refrigeration piping and through nozzles, its pressure reduces and so also the temperature. This water refrigerant then enters the evaporator where it produces the cooling effect. This cycle is repeated continuously. Lithium bromide on the other hand, leaves the generator and reenters the absorber for absorbing water refrigerant.

As seen in the image above, the condenser water is used to cool the water refrigerant in the condenser and the water-Li Br solution in the absorber. Steam is used for heating water-Li Br solution in the generator. To change the capacity of this water-Li Br absorption refrigeration system the concentration of Li Br can be changed.

Comparison between vapour compression and vapour absorption systems:

Compression systems	Absorption systems
Work operated	Heat operated
High COP	Low COP (currently maximum ≈ 1.4)
Performance (COP and capacity) very sensitive to evaporator temperatures	Performance not very sensitive to evaporator temperatures
System COP reduces considerably at part loads	COP does not reduce significantly with load
Liquid at the exit of evaporator may damage compressor	Presence of liquid at evaporator exit is not a serious problem
Performance is sensitive to evaporator superheat	Evaporator superheat is not very important
Many moving parts	Very few moving parts
Regular maintenance required	Very low maintenance required
Higher noise and vibration	Less noise and vibration
Small systems are compact and large systems are bulky	Small systems are bulky and large systems are compact

