

HYDRAULICS

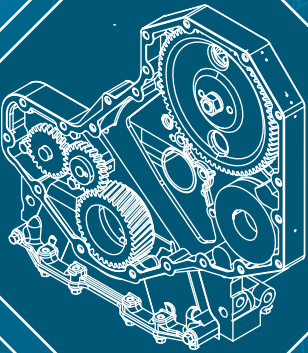
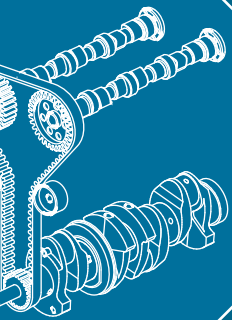
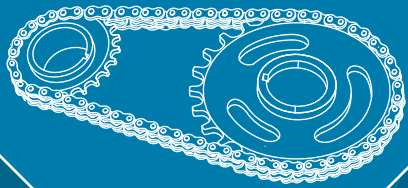

3

BASIC LEVEL
MECHANICS

Table of Contents

1. Basic principles of hydraulics	1
1.1 Additional component needed to run a Hydraulic System.....	3
2. Control valve (4/3 valve)	4
2.1 A Pressure Relief Valve.....	4
2.2 The Pros and Cons of Hydraulics.....	4
2.3 Two major Types of Hydraulic systems are used today.....	5
2.4 Variations on Open and Closed Center Systems.....	6
2.5 Control Valves.....	8
2.6 Open Center System with Series Connection.....	9
2.7 Open Center System with Series / Parallel Connection.....	10
3. Hydraulic pumps	11
3.1 Positive Displacement pump.....	12
3.1.1 Fixed Displacement.....	12
3.1.2 Variable Displacement.....	12
3.2 Types of Hydraulic Pumps.....	13
3.3 Axial Piston Pump (Variable Displacement).....	14
3.4 Gear pumps.....	14
3.4.1 External Gear Pump.....	15
3.4.2 Internal Gear Pump.....	16
3.5 Vane pumps.....	17
3.5.1 Balanced vane pump.....	17
3.5.2 Unbalanced vane pump.....	18
3.6 Piston pumps.....	20
3.6.1 Axial Piston Pumps.....	20
3.6.1.1 In-line Axial Piston Pumps.....	21
3.6.1.2 Axial Piston Pump.....	22
3.6.1.3 Bend-Axis Axial Piston Pump.....	24
3.6.2 Radial Piston Pumps.....	25
3.7 Hydraulic Pump Efficiency.....	26
3.8 Pump Qualities.....	26
3.9 Pump Delivery, Pressure and Speed.....	27
4. Safety	28
5. Hydraulic valves	29
5.1 Introduction.....	29

5.2 Pressure Control Valves.....	30
5.3 Relief Valves.....	30
5.3.1 Direct Acting Relief Valves.....	30
5.3.2 Pilot Operated Relief Valves.....	32
5.4 Pressure Reducing Valves.....	33
5.5 Pilot Operated Types.....	34
5.6 Pressure Sequence Valves.....	35
5.7 Unloading Valves.....	36
5.8 Unloading Valves for Accumulator Circuits.....	36
6. Hydraulic cylinders.....	37
6.1 Introduction.....	37
6.2 Double Acting Cylinders.....	40
6.3 Cushions (Hydraulic Buffer).....	41
6.4 Maintenance of Cylinders.....	42
6.5 Bleeding Air from Remote Cylinders.....	43
6.6 Caution.....	44
6.7 Basic Hydraulic System.....	45
7. Hydraulic accumulators.....	46
7.1 Introduction.....	46
7.2 Pneumatic Accumulators.....	48
7.3 Bladder Type Accumulators.....	48
7.4 Precautions.....	50
7.4.1 Checking Precharged Accumulator on the Machine.....	50
7.4.2 Before Removing Accumulator from Machine.....	51
7.4.3 Repairing Accumulator.....	51
7.4.4 Precharging Accumulator.....	52
7.4.5 Installing Accumulator on Machine.....	52
7.5 New Developments.....	52
8. Practical Exercise.....	53

1. Basic Principles of Hydraulics

The basic principles of hydraulics are:

- Liquids have no shape of their own
- Liquids are practically incompressible
- Liquids transmit applied pressure in all directions
- Liquids provide great increases in work force

A) Liquids have no shape of their own

They acquire the shape of any container. Because of this, oil in a hydraulic system will flow in any direction and into a passage of any size or shape.

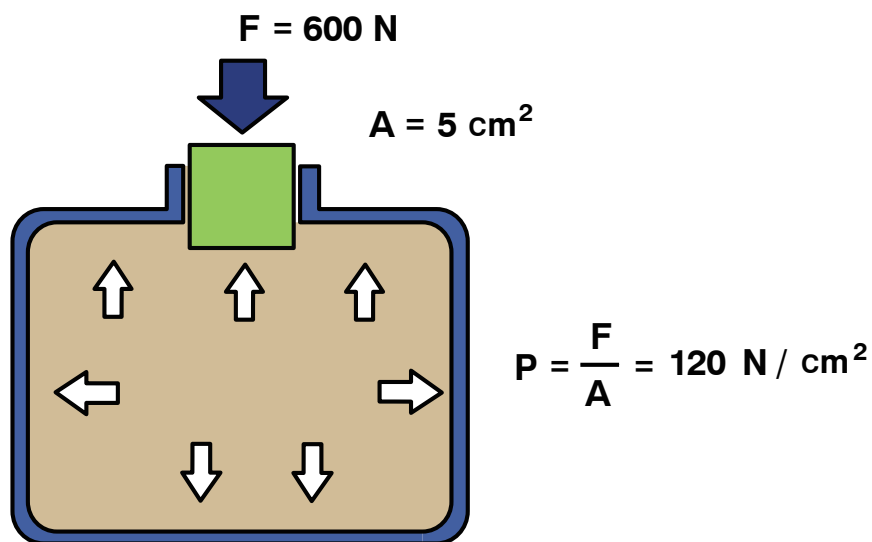

B) Liquid transmit applied pressure in all directions

The experiment in the glass jar will shatter the glass jar and also showed how liquids transmit pressure in all directions when they are put under compression. This is very important in a hydraulic system.

A force of 600N on top of the cork will transmit a pressure of $P = 600 : 5 = 120 \text{ N/cm}^2$

This pressure is created throughout the system, and an equal force of 120N/cm^2 is applied to all the walls (and cork) of the jar.

C) Liquids are practically incompressible

For safety reasons, we obviously wouldn't perform the experiment shown. However, if we were to push down on the cork of the tightly sealed jar, the liquid in the jar would not compress. The jar would shatter first.

Note: Liquids will compress slightly under pressure, but for our purposes they are incompressible.

D) Liquids provide great increases in work force

Let's take a bottle jack as an example.

The pump plunger has an area of 7,07 cm² and the large lifting piston has an area of 314 cm².

Weight of the vehicle on the large piston is 1800kg
1800 divided by 314 is 40,5 (kilo)

Required force on the small plunger is 40,5 kilogram.
A small force on the small plunger is able to lift a heavy load (1800kg)

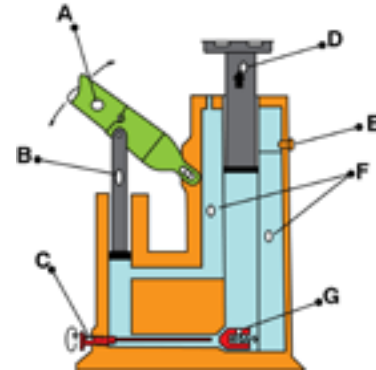
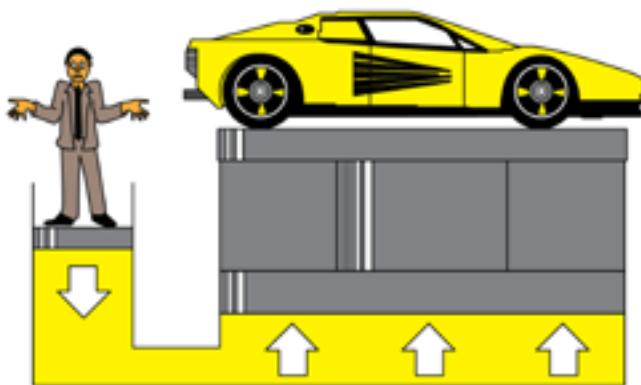

Letter:	Description:
A	Pump plunger with handle
B	Pomp-plunger (with small plunger area)
C	Release valve (for lowering plunger D)
D	Large pump plunger (lifting piston)
E	Filler plug (oil)
F	Hydraulic oil
G	Check valve

For transporting high oil pressures, special hoses are required, reinforced with metal layers.

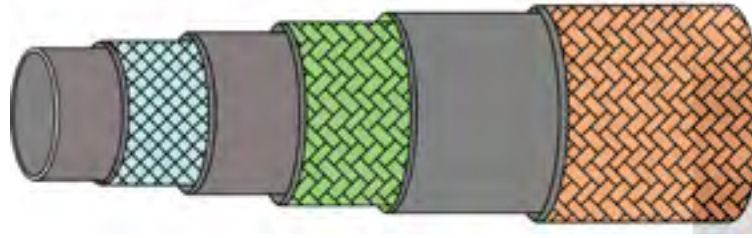

Pressure can be measured by using a manometer.

How a hydraulic system works

A basic hydraulic system has two parts:

- A pump which transports the oil
- The cylinder or hydraulic motor which uses the moving oil to do work.

In effect, the pump converts a mechanical force to hydraulic power, while the cylinder converts the hydraulic power back to mechanical force to do work.

1.1 Additional component needed to run a hydraulic system:

A) Check valves: to hold the oil in the cylinders between strokes and to prevent oil from returning to the reservoir during the pressure stroke. The ball-type valves open when oil is flowing but close when the flow stops.

B) A hydraulic tank (reservoir): to store the oil. If you keep on operating the pump to raise the weight, a supply of extra oil is needed. The reservoir has an air vent which allows oil to be forced into the pump by gravity and atmospheric pressure when the pump piston is retracted.

C) A control valve: directs the oil. This allows the operator to control the constant supply of oil from the pump to and from the hydraulic cylinder. When the control valve is in the neutral position, the flow of oil from the pump goes directly through the valve to a line which carries the oil back to the reservoir. At the same time, the valve has trapped oil on both sides of the hydraulic cylinder, thus preventing its movement in either direction.

2. Control valve (4/3 way valve)

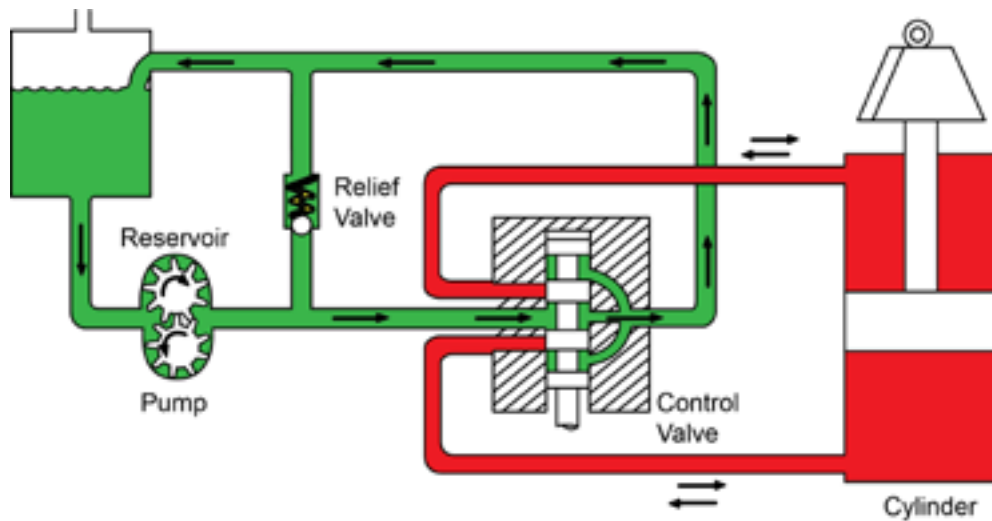

2.1 A pressure relief valve

Basically protects the system from high pressures. If the pressure required to lift the load is too high, this valve opens and relieves the pressure by dumping the oil back to the reservoir.

The relief valve is also required when the piston reaches the end of the stroke. At this time there is no other path for the oil and it must be returned to the reservoir through the relief valve.

2.2 The pros and cons of hydraulics

As you have seen in the simple hydraulic system, we have just developed, the purpose is to transmit power from a source (engine or motor) to the location where this power is required for work.

To look at the advantages and disadvantages of the hydraulic system, let's compare it to the other common methods of transferring this power. These would be mechanical (shafts, gears, or cables) or electrical.

A) Advantages

1. **Flexibility:** Unlike the mechanical method of power transmission where the relative positions of the engine and work site must remain relatively constant with the flexibility of hydraulic lines, power can be moved to almost any location.

2. **Multiplication of force:** In the hydraulic system, very small forces can be used to move very large loads simply by changing cylinder sizes.
3. **Simplicity:** The hydraulic system has fewer moving parts, fewer points of wear. And it lubricates itself.
4. **Compactness:** Compare the size of a small hydraulic motor with an electric motor of equal horsepower. Then imagine the size of the gears and shafts which would be required to create the forces which can be attained in a small hydraulic press. The hydraulic system can handle more horsepower for its size than either of the other systems.
5. **Economy:** This is the natural result of the simplicity and compactness which provide relatively low cost for the power transmitted. Also, power and frictional losses are comparatively small.
6. **Safety:** There are fewer moving parts such as gears, chains, belt and electrical contacts than in other systems. Overloads can be more easily controlled by using relief valves than is possible with the overload devices on the other systems.

B) Disadvantages

1. **Need for cleanliness:** Hydraulic systems can be damaged by rust, corrosion, dirt, heat and breakdown of fluids. Cleanliness and proper maintenance are more critical in the hydraulic system than in the other methods of transmission.

2.3 Two major types of hydraulic systems are used today:

- Open-Center Systems
- Closed-Center Systems

A) Open Center System

The simple hydraulic system shown on page 4 is what we call an Open center system. This system requires the control valve spool to be open in the center to allow pump flow to pass through the valve and return to the reservoir. The pump we have used supplies a constant flow of oil and the oil must have a path for return when it is not required to operate a function.

In the Closed center system, the pump is capable of "taking a break" when oil is not required to operate a function. Therefore, the control valve is closed in the center, which stops (dead ends) the flow of oil from the pump-the "closed center" feature.

Fixed displacement pumps:

are commonly used in combination with an Open center system

Variable displacement pumps:

are commonly used in combination with a Closed center system

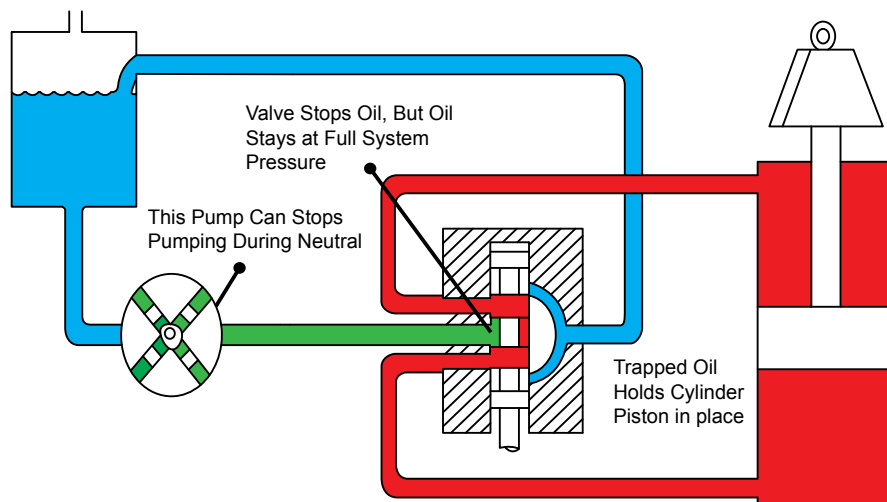
B) Closed Center System

2.4 Variations on Open- and Closed center systems

To operate several functions at once, hydraulic systems have the following connections:

A) Open center systems

- Open-Center with Series Connection
- Open-Center with Series Parallel Connection
- Open-Center with Flow Divider

B) Closed center systems

- Closed-Center with Fixed Displacement Pump and Accumulator
- Closed-Center with Variable Displacement Pump

A family of graphic symbols has been developed to represent fluid power components and systems on schematic drawings. In the United States, the American National Standards Institute (ANSI) is responsible for symbol information. The Institute controls the make-up of symbols and makes changes or additions as required.

The International Standards Organization (ISO) has the same control over symbols used internationally. Both systems have almost the same format (especially since ANSI changed its symbols in 1966 to eliminate all written information).

Standard symbols allow fluid power schematic diagrams to be read and understood by persons in many different countries, even when they don't speak the same language. Either symbol set (ANSI or ISO) may be -- and is -- used in the United States.

However, many companies today use the ISO symbols as their standard for work with foreign suppliers and customers. In order to simplify drawings of hydraulic systems, we will continue this book using ISO symbols.

Instead of drawing complicated circuit diagrams, using pictures of original machine components, hydraulic symbols are easy to draw and Internationally recognisable as uniform language on hydraulic systems.

Example:

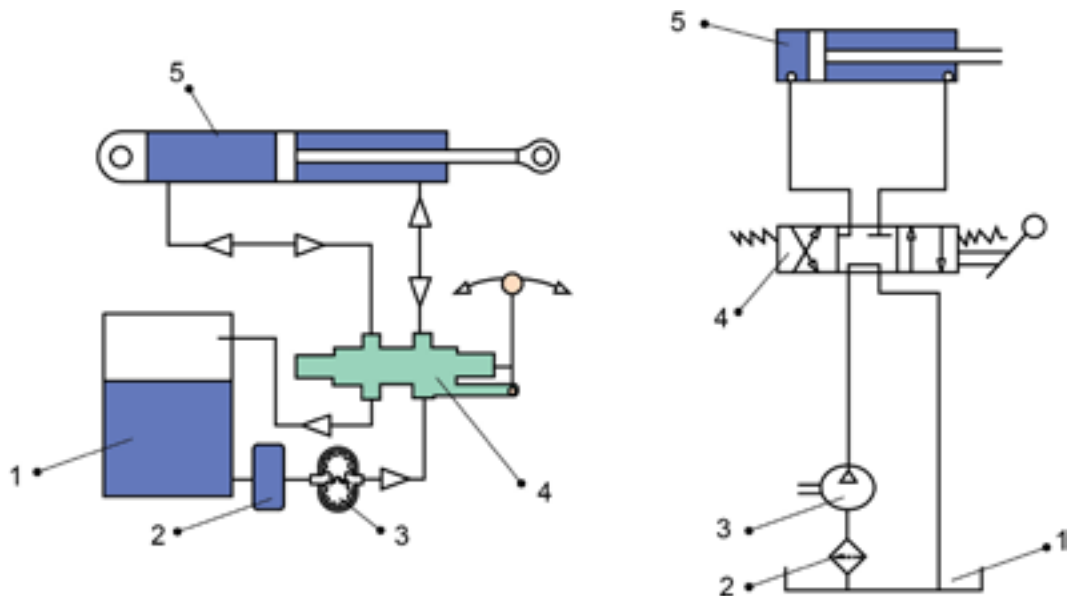

Number:	Description:
1	Hydraulic oil tank (reservoir)
2	Suction filter (strainer)
3	Hydraulic oil pump
4	Hydraulic control valve
5	Hydraulic cylinder (double acting

The advantage of using symbols instead of pictures of original components, symbols are designed in such a way that the kind of valve can be recognised easily.

Number 4 in the picture above, is a 4/3 way valve with open centre. The symbol has all the information you need to know what kind of valve it is.

2.5 Control valves

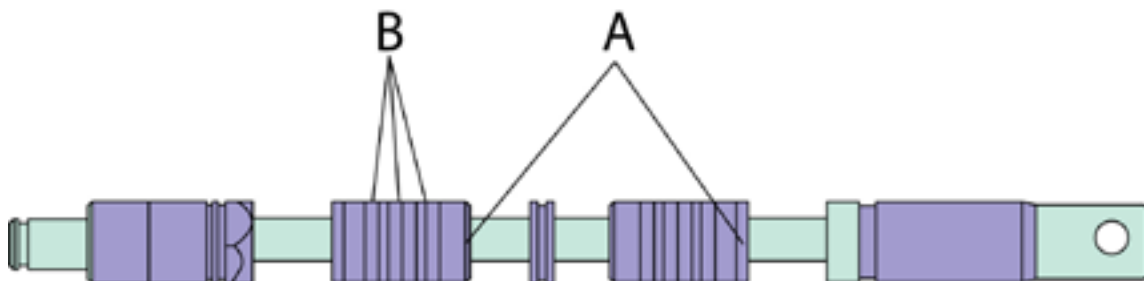

Control valves can be operated by hand, by oil (servo) and electric (solenoid).

The spool valve itself consists of a number of lands having slots "A" to meter the oil.

The grooves labeled "B" are used as a kind of hydraulic bearing/seal.

Spool slots are available in all kind of shapes, depending on the sensitivity required for each particular system.

Solenoid operated valves are available in On / Off shifting valves and Proportional operated valves.

2.6 Open-Center System with Series Connection

Oil from the pump is routed to the two control valves in series.
When the 1st valve is operated, no oil will reach the 2nd valve.

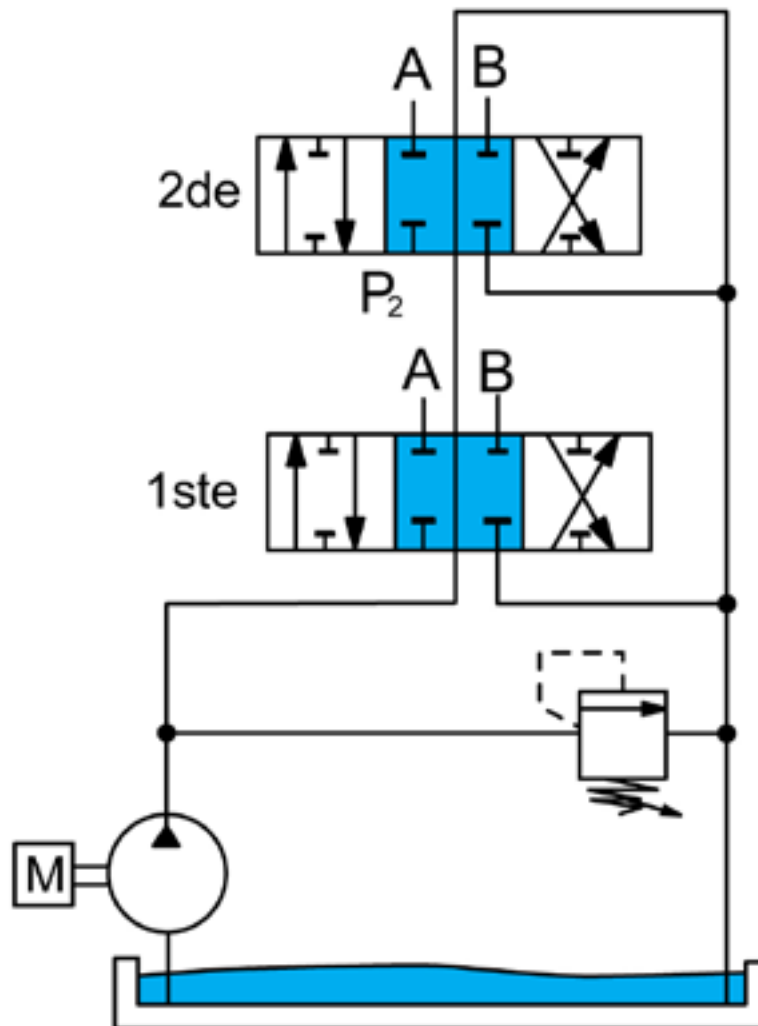

In neutral, the oil passes through the valves in series and returns to the reservoir as shown by the arrows. When a control valve is operated, incoming oil is diverted to the cylinder which that valve serves.

This system is satisfactory as long as only one valve is operated at a time. In this case the full output of the pump at full system pressure is available to that function. However, if more than one valve is operated, the total of the pressures required for each individual function cannot exceed the system relief setting.

2.7 Open-Center System with Series / Parallel Connection

This system, shown below, is a variation on the series connected type. Oil from the pump is routed through the control valves in series- but also in parallel. The valves are sometimes "stacked" to allow for the extra passages.

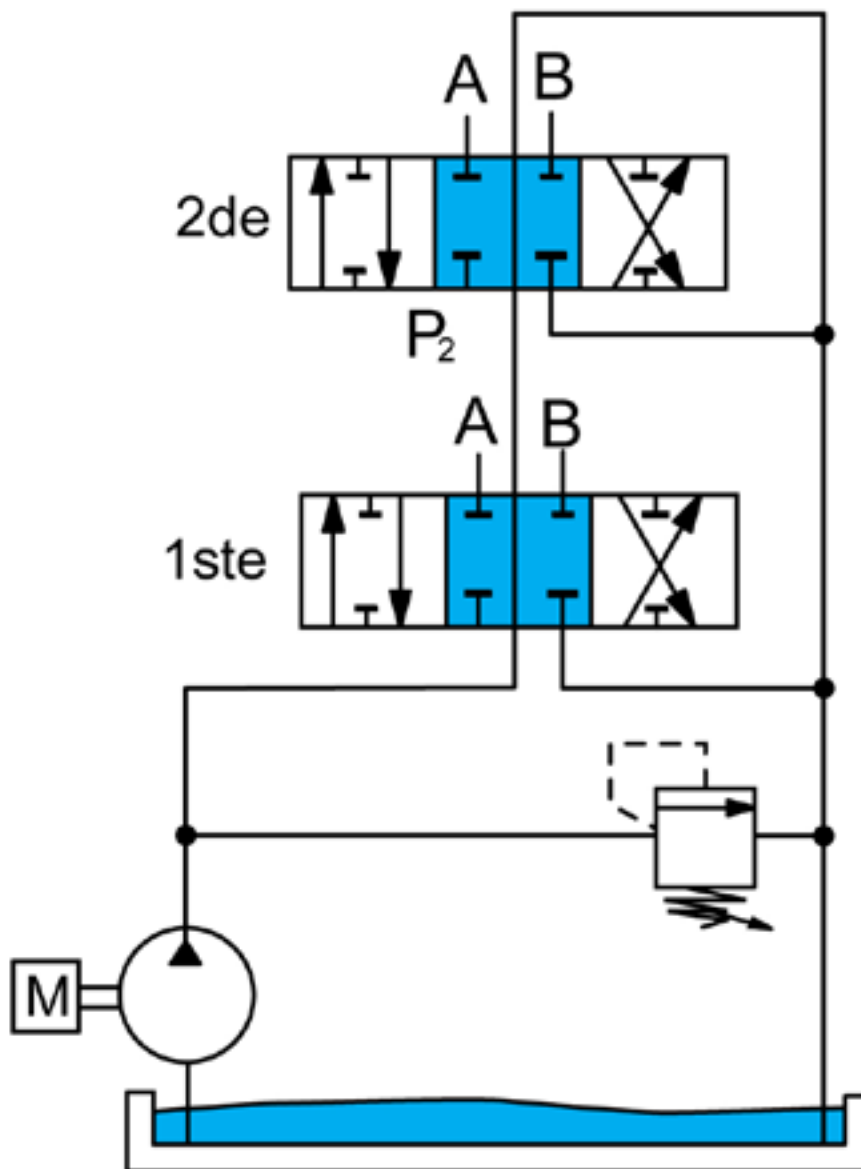

In neutral, the oil passes through the valves in series as shown by the arrows.

Valve 2 and 3 are a combination of series and parallel connection. When valve 2 is operated, valve 3 is also receiving oil and can be operated at the same time.

3. Hydraulic pump

The pump is the heart of the hydraulic system. It creates the flow of fluid which supplies the whole circuit.

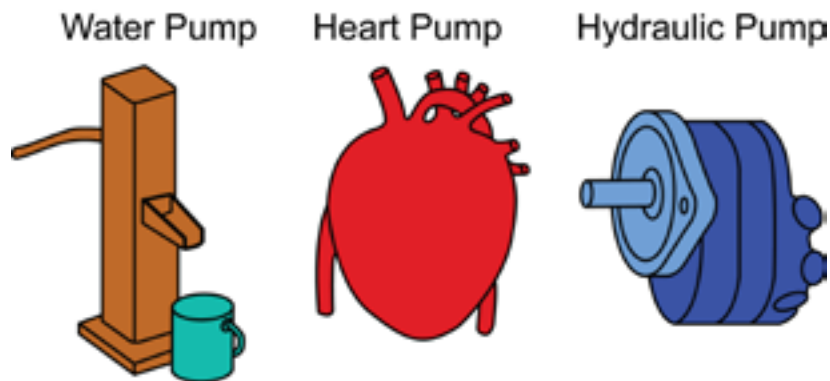

The human heart is a pump. So was the old water pump once found on the farm.

Once the term "hydraulics" meant the study of fluids in motion. Therefore, any pump which moved fluids was considered a hydraulic pump.

But today, "hydraulics" means the study of fluid pressure and flow-fluids in motion plus the ability to do work.

When is a pump hydraulic

All pumps create flow. They operate on a principle called **displacement**. The fluid is taken in and displaced to another point.

Displacement can be done in two ways:

- Non-Positive Displacement
- Positive Displacement

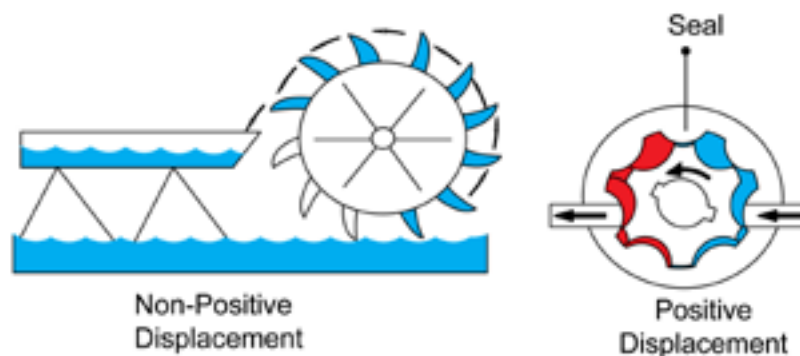

3.1 Positive displacement pump

But the positive displacement pump, used in hydraulics today, not only creates flow, it also backs it up. Notice the sealed case around the gear. This traps the fluid and holds it while it moves.

As the fluid flows out the other side, it is sealed against back-up. This sealing is the “positive” part of displacement. Without it, the fluid could never overcome the resistance of the other parts in the system.

When high pressure is needed in a circuit, a positive displacement pump is a must. This is true for all modern hydraulic systems which provide fluid power.

In low-pressure systems, such as water cooling or crop spraying types, the old non-positive displacement pump still works.

In this chapter, we will discuss only the **positive displacement** pump which is the heart of modern oil hydraulic systems. This pump is a true hydraulic pump.

Displacement of hydraulic pump

“Displacement” is the volume of oil moved or displaced during each cycle of a pump.

In this sense, hydraulic pumps fall into two broad types:

- Fixed Displacement Pumps
- Variable Displacement Pumps

3.1.1 Fixed displacement

Pumps move the same volume of oil with every cycle. This volume is only changed when the speed of the pump is changed.

Volume can be affected by the pressure in the system, but this is due to an increase in leakage back to the pump inlet. Usually this occurs when pressure rises.

This leakage means that fixed displacement pumps are usually found in lower pressure systems or as aids to another pump in a higher pressure system.

3.1.2 Variable displacement

Variable displacement pumps can vary the volume of oil they move with each cycle-even at the same speed. These pumps have an internal mechanism which varies the output of oil, usually to maintain a constant pressure in the system.

- When system pressure drops, volume increases
- As pressure rises, volume decreases.

Remember:

A hydraulic pump does not create pressure: it creates flow.

Pressure is caused by resistance to flow !

3.2 Types of hydraulic pumps

Now that we have seen what hydraulic pumps are and what they can do, let's take an "inside" look.

a)

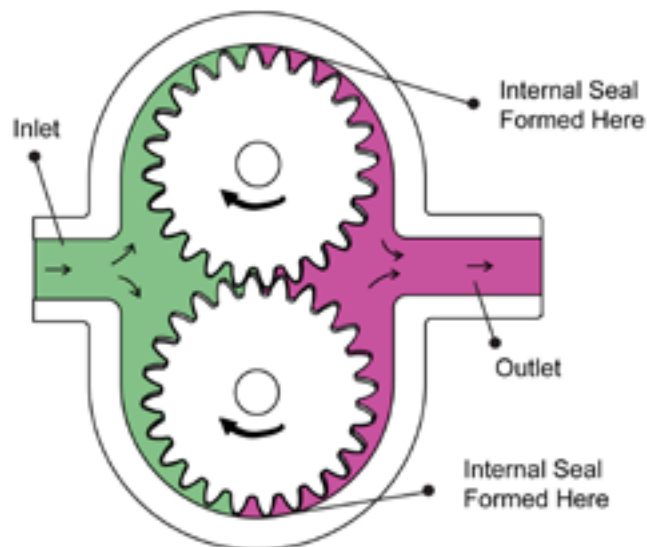

b)

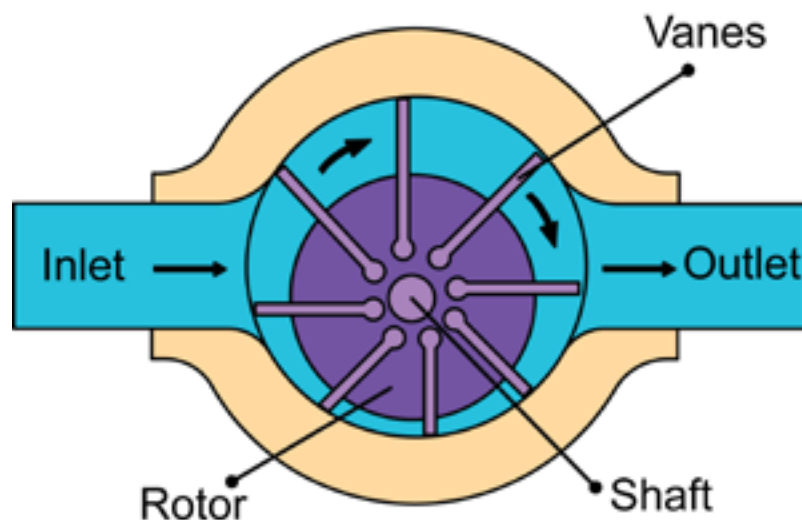

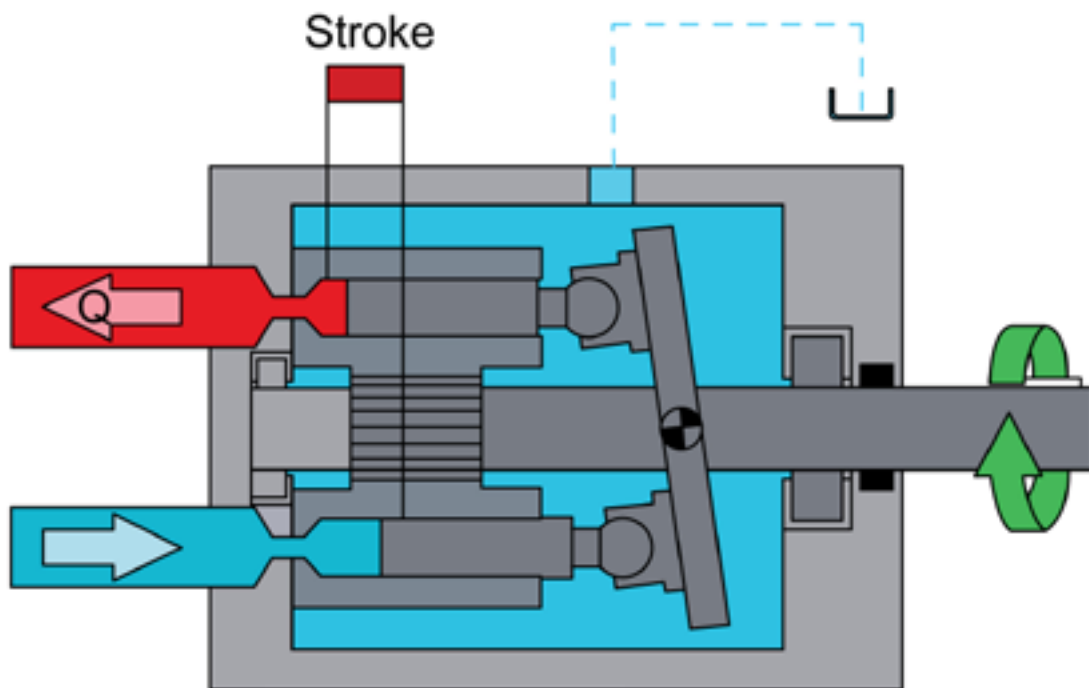

3.3 Axial Piston Pump (Variable Displacement)

We will show how each type of pump operates and how it is used. A hydraulic system may use one of these pumps, or it may use two or more in combination.

All three designs work on the rotary principle: a rotating unit inside the pump moves the fluid. A rotary pump can be built very compact, yet displace the necessary volume of fluid. This is the number one need in a mobile system where space is limited.

3.4 Gear pumps

Gear pumps are of the fixed displacement type. Two types being External gear type and Internal gear type. They are widely used because they are simple and economical. While not capable of variable displacement, they can produce the volume needed by most systems using fixed displacement. Often they are used as charging pumps for larger system pumps of other types. Servo systems also make use of gear pumps.

Basic types of gear pumps are used:

- External Gear Pumps
- Internal Gear Pumps

3.4.1 External gear pump

External gear pumps usually have two gears in mesh, closely fitted inside a housing. The drive shaft drives one gear, which in turn drives the other gear. Shaft bushings and machined surfaces or wear plates are used to seal in the working gears.

Operation

Operation is quite simple. As the gears rotate and come out of mesh, they trap inlet oil between the gear teeth and the housing. The trapped oil is carried around to the outlet chamber. As the gears mesh again they form a seal which prevents oil from backing up to the inlet. The oil is forced out at the outlet port and sent through the system.

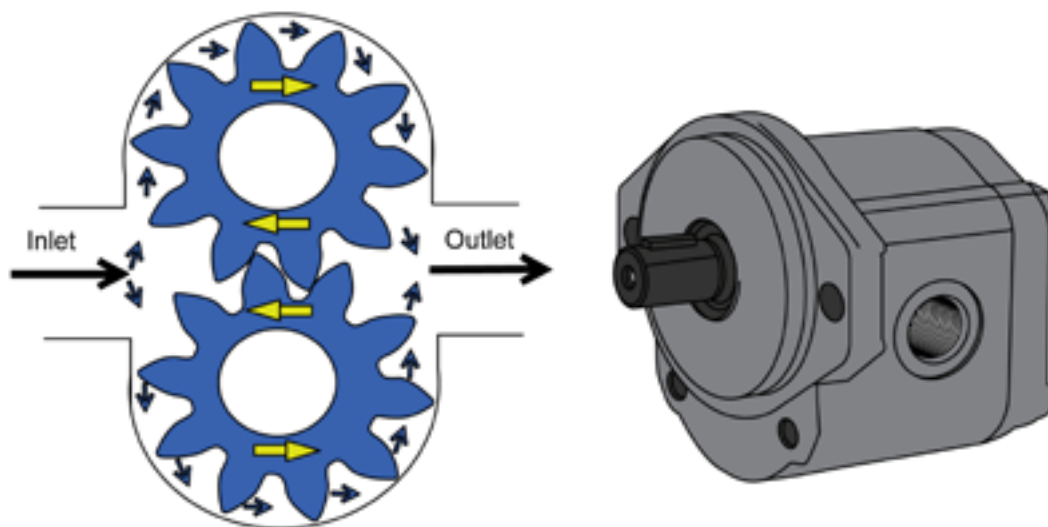

This oil is pushed out by the continuous flow of trapped oil coming into the outlet chamber with each rotation of the gears. At the inlet side, gravity feeds in more oil from the reservoir to replace that drawn out by the turning gears.

Some gear pumps use a pressurized plate working against the gears to increase pump efficiency. A small amount of pressure oil is fed under the backing plate, pressing it against the gears and forming a tighter seal against leakage.

3.4.2 Internal gear pump

The internal gear pump also uses two gears, but now a spur gear is mounted inside a larger gear. The spur gear is in mesh with one side of the larger gear, and both gears are divided on the other side by a crescent-shaped separator. The drive shaft turns the spur gear, which drives the larger gear.

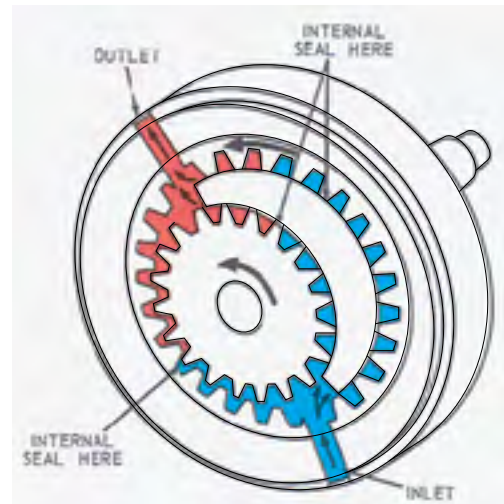

Operation

Operation is basically the same as for the external gear pump. The major difference is that both gears turn in the same direction.

As the gears come out of mesh, oil is trapped between their teeth and the separator and is carried around to the outlet chamber. As the gears mesh again, a seal is formed, preventing back-up of the oil. A continuous flow of oil to the outlet pushes the fluid out into the circuit. Gravity keeps feeding oil into the pump inlet to fill the partial vacuum created as oil is drawn in by the gears.

3.5 Vane pumps

Vane pumps are fairly versatile pumps and can be designed as single, double, or even triple units.

All vane pumps move oil using a rotating slotted rotor with vanes fitted into the slots.

Two types of vane pumps are most often used:

- Balanced Vane Pumps
- Unbalanced Vane Pumps

The balanced vane pump is strictly a fixed displacement type. The unbalanced vane can have a fixed or a variable displacement.

3.5.1 Balanced vane pumps

In the balanced vane pump, the rotor is driven by the drive shaft and turns inside an oval rotor ring.

The vanes are fitted into the rotor slots and are free to move in or out.

The “balanced” part of this pump is shown by the position of the oil ports. The pump has two inlet ports, located opposite each other. And it has two outlet ports, also on opposite sides of the pump. Both sets are connected to a central inlet and outlet.

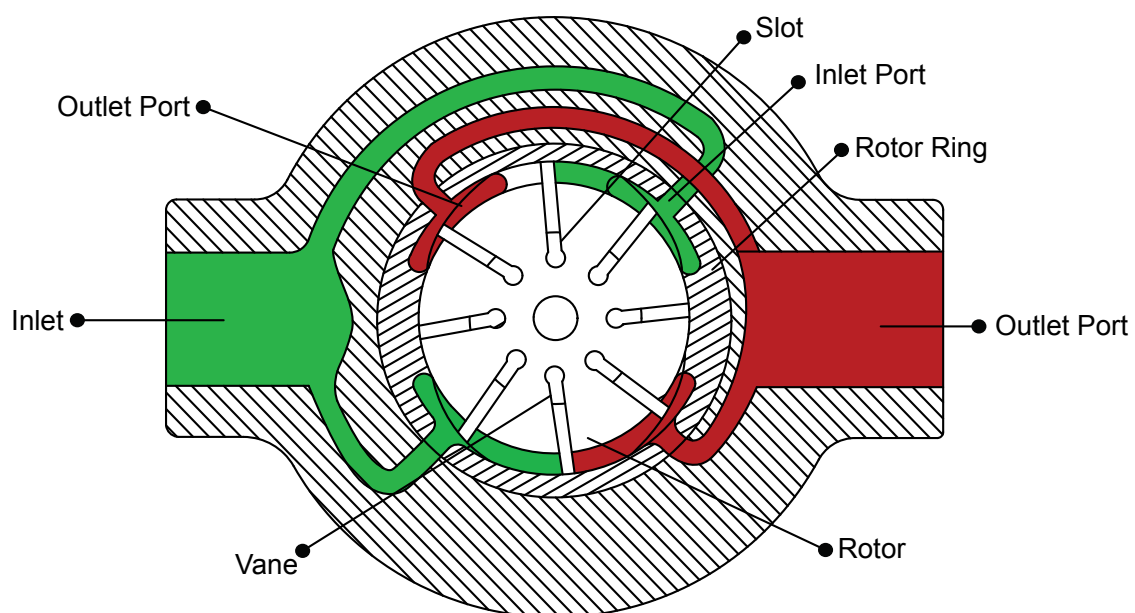

Operation

As the rotor turns, the vanes are thrown out against the inside surface of the ring by centrifugal force. As the vanes follow the contour of the oval-shaped ring, they divide the crescent-shaped areas between the rotor and the ring into two separate chambers. These chambers are continually expanding and shrinking in size—twice during each revolution. The inlet ports are located where each chamber begins to expand: the outlet ports are located where each chamber begins to shrink.

As the chamber begins to expand, inlet oil rushes in to fill the partial vacuum. This oil is carried around by the vanes. As the oil chamber begins to reduce, the confined oil is forced out at the outlet port.

In the second half of the revolution, this action is repeated at the second set of inlet and outlet ports.

3.5.2 Unbalanced vane pumps

The unbalanced vane pump uses the same basic principle of a turning rotor with vanes working inside a fixed rotor ring.

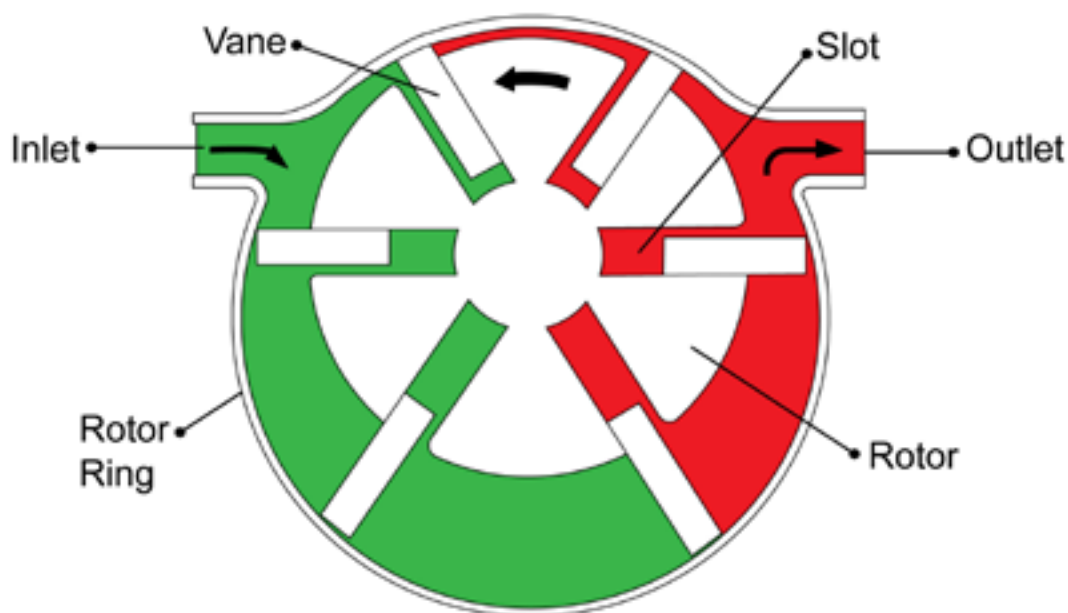

However, the operating cycle only happens once each revolution. So this pump has only one inlet and one outlet port. Also, the slotted rotor is now set offside in a circular ring.

In operation, the oil chamber starts to expand at the inlet port, and finishes its contracting at the outlet port.

Oil is drawn in by the partial vacuum, and forced out by the shrinking of the chamber, the same as in the balanced vane pump.

However, the design of the unbalanced vane pump is different from the balanced type, as we'll explain now.

Balanced vane pumps cannot operate as variable displacement pumps.

Unbalanced pumps can be used as a variable displacement pump.

The balanced vane pump is really a refinement of the unbalanced model. Why was this refinement needed?

The unbalanced vane pump seemed to have frequent bearing failures. The cause was found to be force on the shaft and bearings of the back pressure from oil being expelled at the outlet side of the pump. No equal force was exerted on the opposite side, since the inlet oil was under little or no pressure.

The balanced vane pump was a solution to this problem. To balance off the outlet pressures on the shaft, two (2) outlet ports were used, directly opposite each other. This equalized the forces, increased bearing life, and made the pump work longer.

While the balanced vane pump solved one problem, it posed another one: it could only be used for fixed displacement. The outlet port positions cannot be changed or the balance would be upset.

The unbalanced model can be used either for fixed or variable displacement. By special design, the position of its rotor ring and oil ports can be changed in relation to the offset of the rotor. This changes the size of the chambers which the vanes create, thus the amount of oil each carries. The result: a variable displacement pump.

3.6 Piston pumps

Piston pumps are often favored on modern hydraulic systems which use high speeds and high pressures. However, piston pumps are more complex and more expensive than the other two types. Piston pumps can be designed for either fixed or variable displacement.

- **Axial Piston Pumps**
- **Radial Piston Pumps**

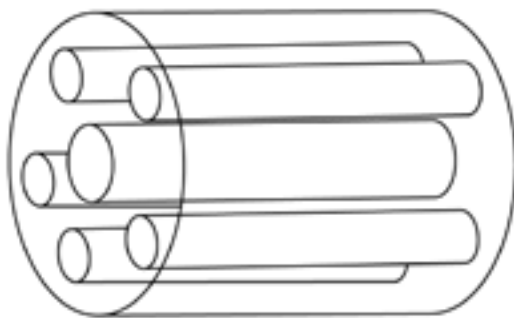

Axial Piston

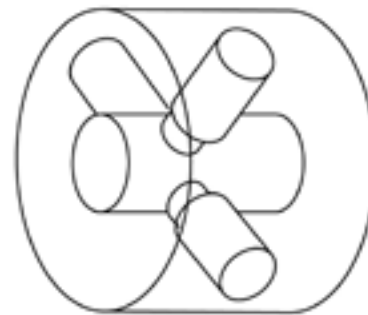

Radial Piston

3.6.1 Axial Piston pumps

AXIAL piston means that the pistons are mounted in lines parallel with the pump's "axis" (a line down the center).

RADIAL piston means that the pistons are set perpendicular to the pump's center like the sun's rays.

Both styles of piston pumps operate using pistons which pump oil by moving back and forth in cylinder bores. (Another term for this movement is "reciprocate.")

Axial and radial piston pumps use reciprocating pistons but drive them by the rotary principle. In this way the efficiency of the reciprocating method is combined with the compactness of the rotary operating pump.

The result is a pump which is efficient, yet can fit into a machine hydraulic system.

Axial piston pumps usually fall into two broad types: inline and bent-axis.

3.6.1.1 In-line Axial Piston Pumps

In this pump, the cylinder block is mounted on a drive shaft and rotates with the shaft. The pistons work in bores in the cylinder block which are parallel to the axis of the block. The heads of the pistons are in contact with a tilted plate called a swashplate.

The swashplate does not turn but it can be tilted back and forth. It mounts on a pivot and is controlled either manually or by an automatic "servo" device.

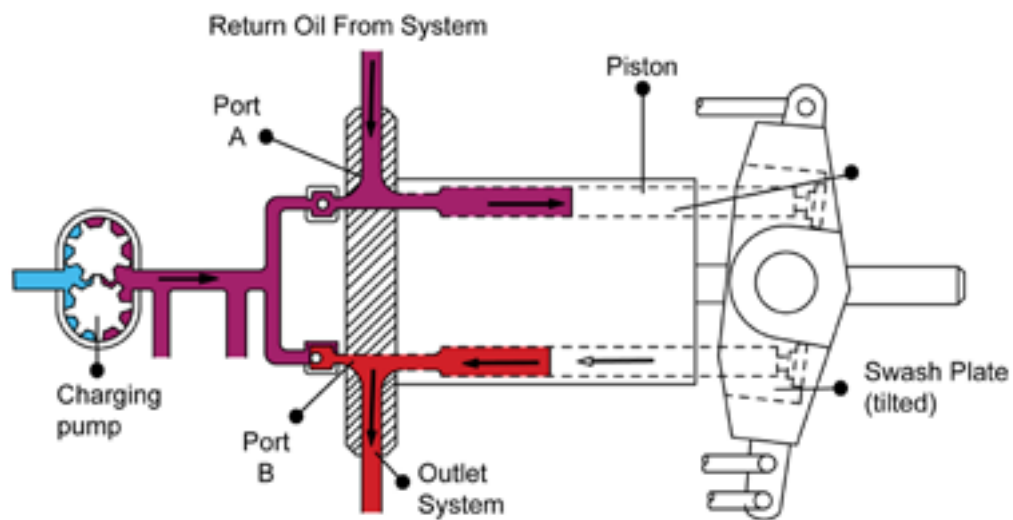

Since the swashplate controls the output of the pistons, this pump has a variable displacement.

Remember that the angle of the swashplate controls the distance that the pistons can move back and forth in their bores. The greater the angle, the farther the pistons travel and the more oil that is displaced by the pump.

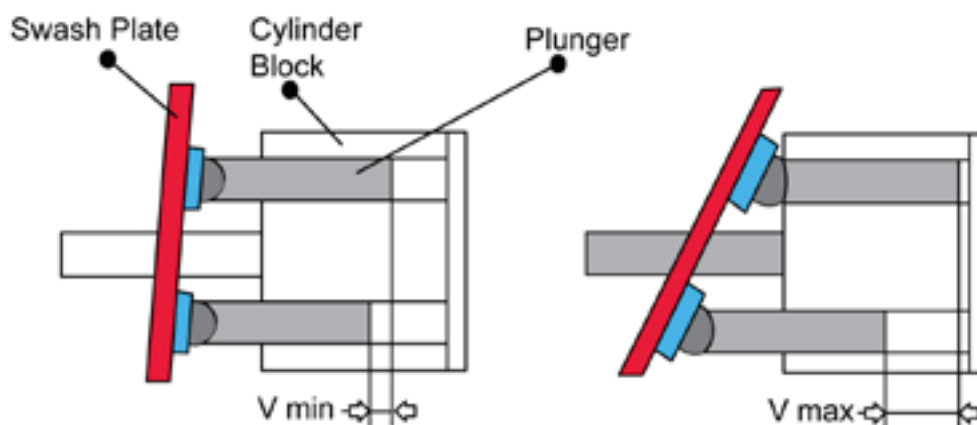

When the swashplate is tilted as shown. As the cylinder block rotates, piston bores align with this port and oil is forced into the bores by the small charging pump. This oil pushes the pistons against the swashplate. Then as they revolve, these pistons follow the tilt of the swashplate and force the oil out of their bores into the outlet port.

If the angle of the swashplate was fixed, the pump would operate as a fixed displacement type, putting out the same amount of oil with each revolution.

Swash Plate



Bend Axis



The bend axis shown above is of the fixed displacement type. It is often used as hydraulic motor driving the tracks of hydraulic excavators.

3.6.1.2 Axial piston pump

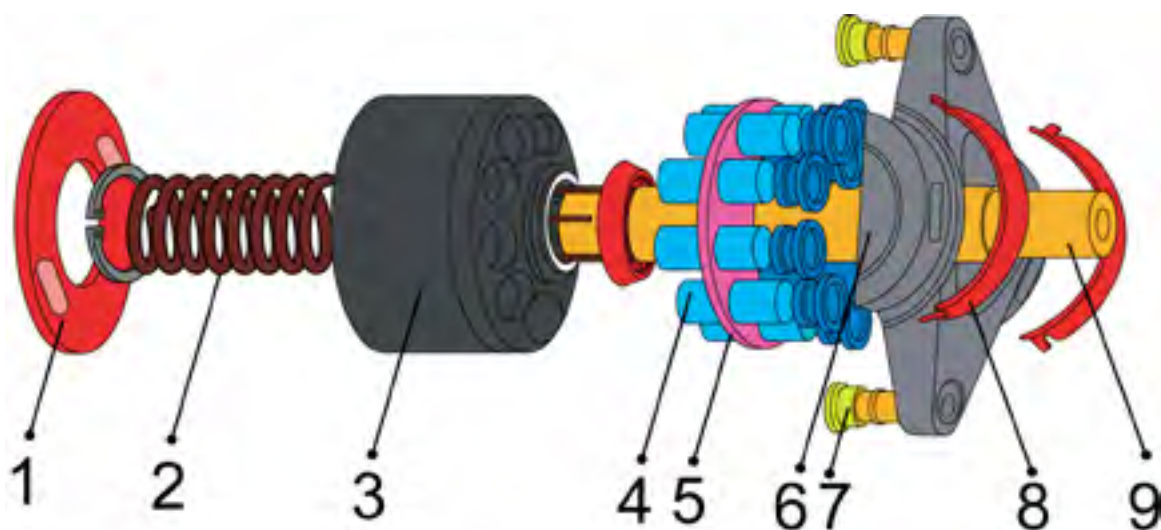

Number:	Description:
1	Port plate (inlet and outlet ports)
2	Heavy coil spring
3	Cylinder block (holding the pistons/plungers)
4	Plungers (or pistons)
5	Piston slippers retraction ring
6	Swash plate
7	Servo controlled operation of swash plate
8	Bearings shells of swash plate (often needle bearing)
9	Drive shaft of cylinder block

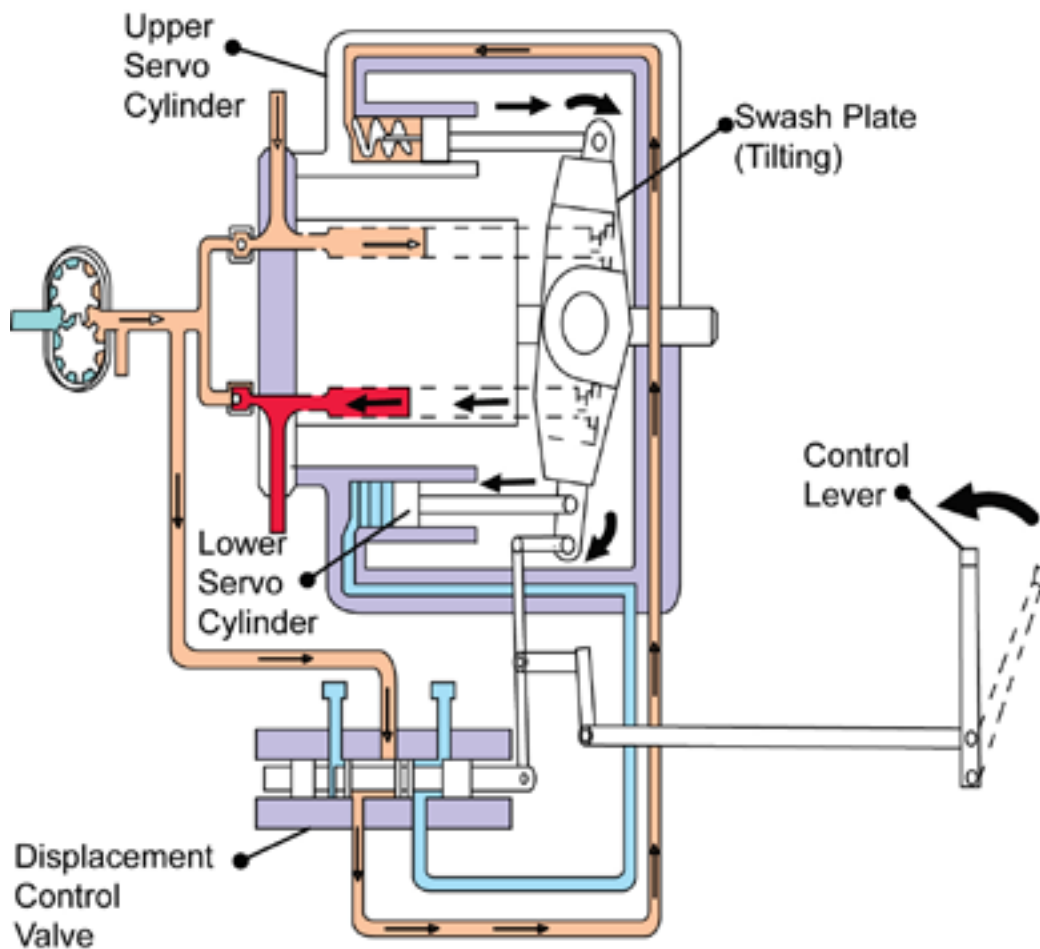

To tilt the swashplate, the control lever is actuated, moving the displacement control valve to the left. This directs oil from the charging pump into the upper servo cylinder, moving the piston which tilts the swashplate.

Meanwhile the piston in the lower servo cylinder is pushed in by the lower part of the swashplate, forcing its oil back through the valve to the pump case.

When the swashplate reaches the angle set by the control lever, the control valve returns to neutral and traps the oil in the servo cylinders. This holds the swashplate until the control lever is moved again.

The pump keeps on pumping as explained before, drawing in oil at the top and pushing out oil at the bottom of each revolution.

If the swashplate were tilted the opposite way, the inlet-outlet cycle of the pump would be reversed. Oil would be drawn in at the bottom and pushed out at the top. So the servo device not only controls the pump displacement but also the direction of this oil.

3.6.1.3 Bend-Axis Axial Piston Pump

As explained earlier, the bend axis is a fixed displacement type of pump.

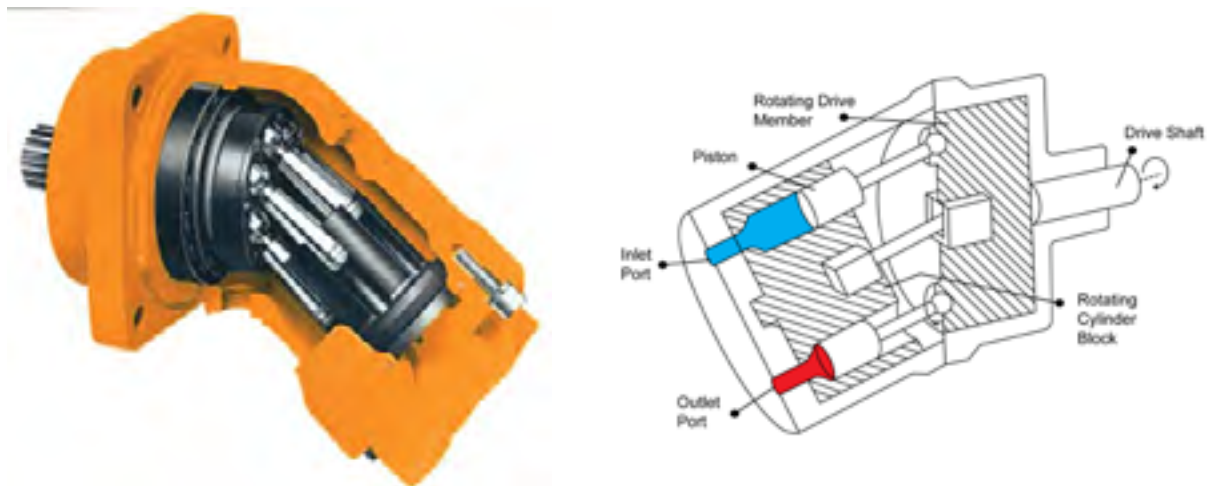

Hydrostatic driven wheel loaders used to be equipped with bent axis hydraulic **motors**. Since more difference in speed and torque is needed, the latest type of wheel loaders are equipped with a axial piston pump, variable displacement, two directions of flow. The hydraulic motors are no longer of fixed displacement type but are variable and some Wheel loader have two of them fixed onto the transfer box (high and low speed).

Radial piston pumps

Radial piston pumps are among the most sophisticated of all pumps. They are capable of high pressures, high volumes, high speeds, and variable displacement.

The basic operation is simple, but by using extra valves and other devices, this pump can be adapted to many systems and needs.

This pump is closely fitted, so wear can be a problem unless clean oil is used. And the oil must contain properties which lubricate the closely fitted parts.

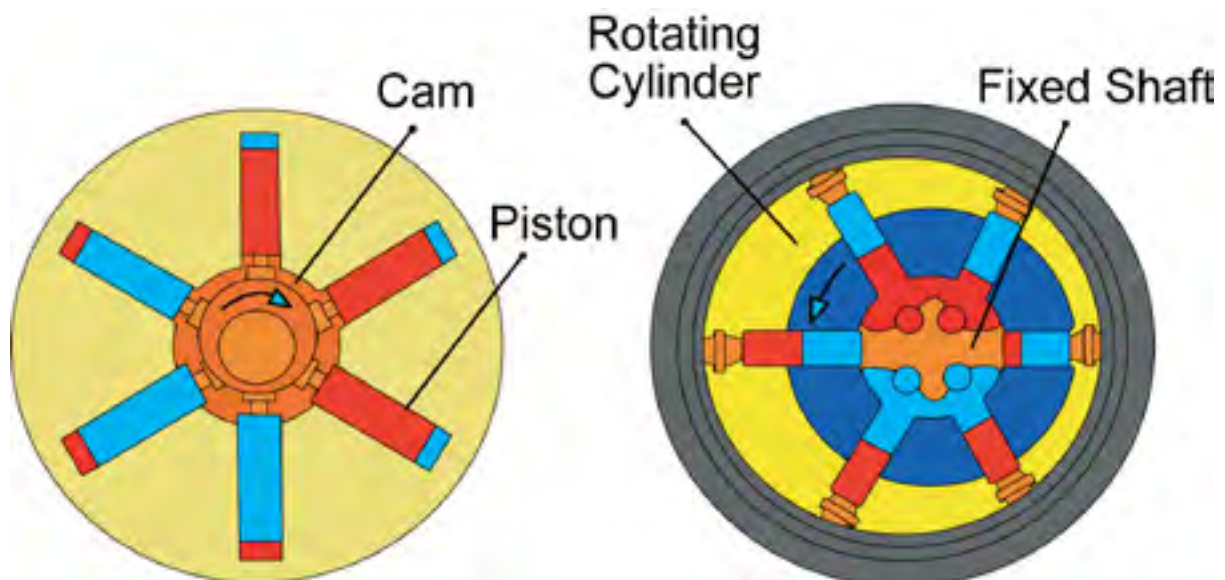

Radial piston pumps are designed to operate in two ways.

In the "rotating cam" pump, the pistons are located in a fixed pump body. The center shaft has a cam which drives the pistons as it rotates.

In the "rotating piston" pump, the pistons are located in a rotating cylinder. As the cylinder rotates, the pistons are thrown out against the outer housing. Since the rotating cylinder is set offside in the housing, the pistons are moved back and forth as they follow the housing.

Excavators used to be equipped with Radial piston pumps.

Today most heavy machinery and equipment use axial piston pumps.

In summary:

1. *A hydraulic pump converts mechanical force into hydraulic or fluid power-in other words, induces fluid to work.*
2. *Of the two main types of pumps, positive displacement and non-positive displacement, the positive displacement type is best suited for power hydraulics due to its ability to produce a steady flow against the high pressures in the system.*
3. *A hydraulic pump can be designed to produce either a specific volume of fluid at a specific speed, or to produce a variable volume of fluid at a constant speed . . . fixed displacement or variable displacement.*
4. *The three types of pumps most often used in machine hydraulic Systems are gear, vane, and piston.*
5. *These three pumps operate on a rotary principle. This allows them to be constructed as small units, yet still have the ability to produce the required volume of fluid.*
6. *The preceding text covers only basic hydraulic pumps and there are a great number of variations on all of the pumps selected.*

3.7 Hydraulic pump efficiency

Thus far, we have only described the three most popular types of pumps. This, of course, is not the whole story on hydraulic pumps. Their application and efficiency is just as important as their operation and this may help later in diagnosing hydraulic problems.

3.8 Pump Qualities

Because of the wide variety of pumps and hydraulic systems, we could not possibly prescribe a particular model of pump for a particular system without having full information about the system. However, we can describe the desirable and undesirable qualities of the three pumps and let you judge for yourself the reasons why a particular pump is used in a hydraulic system.

One of the first factors to consider when choosing a pump for a machine system is the pump's physical size. Most of these systems have little or no room to spare and may allow just a small area for the pump.

Fortunately, with the wide variety of pumps and pump sizes available, this is not a big problem unless the system requires a function that a pump cannot provide except as a large unit. In this case, space for the pump, regardless of size, will be made available, because the other more important requirements of the system cannot be sacrificed.

3.9 Pump Delivery, Pressure and Speed

One other requirement is the volume of fluid that the pump produces.

Most pumps are rated by volume, which is usually expressed in Liters per minute (or gallons per minute (gpm)). This rating is called several names - delivery rate, discharge, capacity, or size. Regardless of the rating, it cannot stand alone. It must be accompanied by a figure stating the amount of back pressure that the pump can withstand and still produce the gpm rating: for as pressure increases, internal pump leakage increases and usable volume decreases.

Pump speed must also be included with the volume rating for two reasons.

First, in a fixed displacement pump, flow is directly related to the speed of the pump-the faster the speed, the more fluid pumped.

Second, how fast the pump must go to produce a certain flow indicates at what speed the driving mechanism for the pump must travel (in revolutions per minute or rpm). Add this to the delivery rate of a pump, and here is an example of how a rating could read: "11.5 gpm with 2000 psi at 2100 rpm."

Occasionally, a pump will have an alternate delivery rate, referred to as an intermittent delivery rate. This rating indicates the highest level a pump can operate, in terms of delivery, pump speed and pressure, for a period of time and still maintain satisfactory service life.

Pump efficiency

The efficiency of a pump (how well it does its job) is also important in selecting a pump.

We may have a pump that meets the delivery requirements of a system under the existing pressure in the system at the speed that is available to drive the pump-we may have all this and more but what if we find that the pump requires a great amount of mechanical power to attain this delivery rate? Or what if we find that the materials in the pump must be specially and expensively constructed to withstand the pressure or friction in the system? This is why the knowledge of pump efficiency is important before selecting a particular pump. We are not only looking for delivery rate, but delivery rate provided by efficient and economical operating means.

Pump quality is judged by three ratings:

- Volumetric Efficiency
- Mechanical Efficiency
- Over-All Efficiency

Volumetric efficiency is the ratio of the actual output of the pump to theoretical output (the amount it should put out under ideal conditions). The difference is usually due to internal leakage in the pump.

Mechanical efficiency is the ratio of the overall efficiency of the pump to volumetric efficiency. This difference is usually due to wear and friction on the pump's working parts.

Over-all efficiency is the ratio of the hydraulic power output to the mechanical power input of the pump. This is the product of both mechanical efficiency and volumetric efficiency.

4. Safety

Be always alert of the high pressures in hydraulic systems.

Pressures over 300 bar (kg/cm^2) are very normal in today's hydraulic systems. Peak pressure can even double this amount.

An average piston pump can deliver plus/minus 200 liters per minute. In case of a hose burst or other way of leakage in the system, a lot of oil will be lost. Always top-up the reservoir, after losing oil.

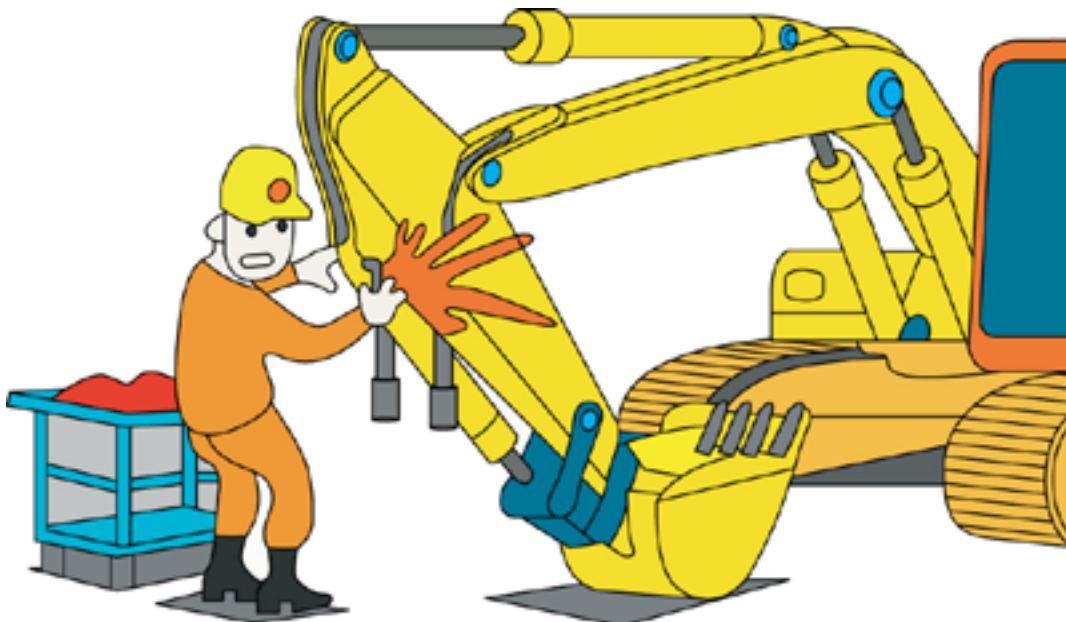

5. Hydraulic Valves

5.1 Introduction

Valves are the controls of the hydraulic system. They regulate the pressure, direction, and volume of oil flow in the hydraulic circuit.

Valves can be divided into three major types:

- Pressure Control Valves
- Directional Control Valves
- Volume Control Valves

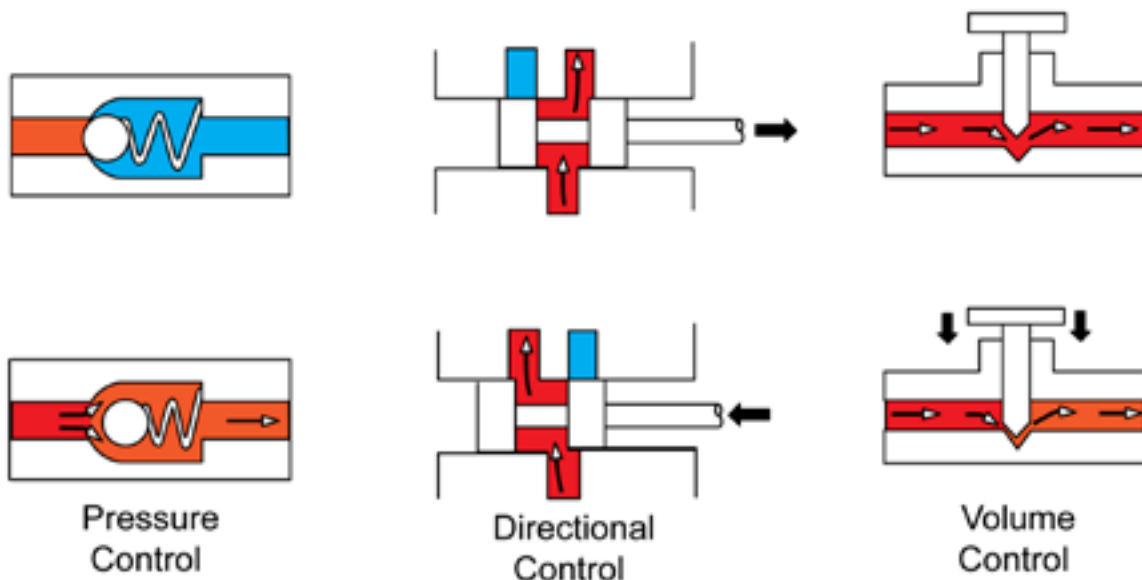

Pressure control valves are used to limit or reduce system pressure, unload a pump, or set the pressure at which oil enters a circuit. Pressure control valves include relief valves, pressure reducing valves, pressure sequence valves, and unloading valves.

Directional control valves control the direction of oil flow within a hydraulic system. They include check valves, spool valves, rotary valves, pilot controlled poppet valves, and electro-hydraulic valves.

Volume control valves regulate the volume of oil flow, usually by throttling or diverting it. They include compensated and non-compensated flow control valves and flow divider valves.

Some valves are variations on the three main types. For example, many volume control valves use a built-in pressure control valve.

Valves can be controlled in several ways: manually, hydraulically, electrically, or pneumatically. In some modern systems, the entire sequence of operation for a complex machine can be made automatic

Let's discuss each type of valve in detail, starting with pressure control valves.

5.2 Pressure control valves

Pressure control valves are used to:

- Limit system pressure
- Reduce pressures
- Set pressure at which oil enters a circuit
- Unload a pump

5.3 Relief valves

Each hydraulic system is designed to operate in a certain pressure range. Higher pressures can damage the components or develop too great a force for the work to be done.

Relief valves remedy this danger.

They are safety valves which release the excess oil when pressures get too high.

Types of relief valves are used:

- **Direct acting** relief valves are simple open-closed valves.
- **Pilot operated** relief valves have a "trigger" which controls the main relief valve.

5.3.1 Direct Acting Relief Valves

When closed, the spring tension is stronger than inlet oil pressure, holding the ball closed on its seat

The valve opens when pressure rises at the oil inlet and overcomes the spring force. Oil then flows out to the reservoir, preventing any further rise in pressure.

The valve closes again when enough oil is released to drop pressure below the tension of the spring. Some relief valves are adjustable. Often a screw is installed behind the spring. By turning the screw in or out, the relief valve can be adjusted to open at a certain pressure.

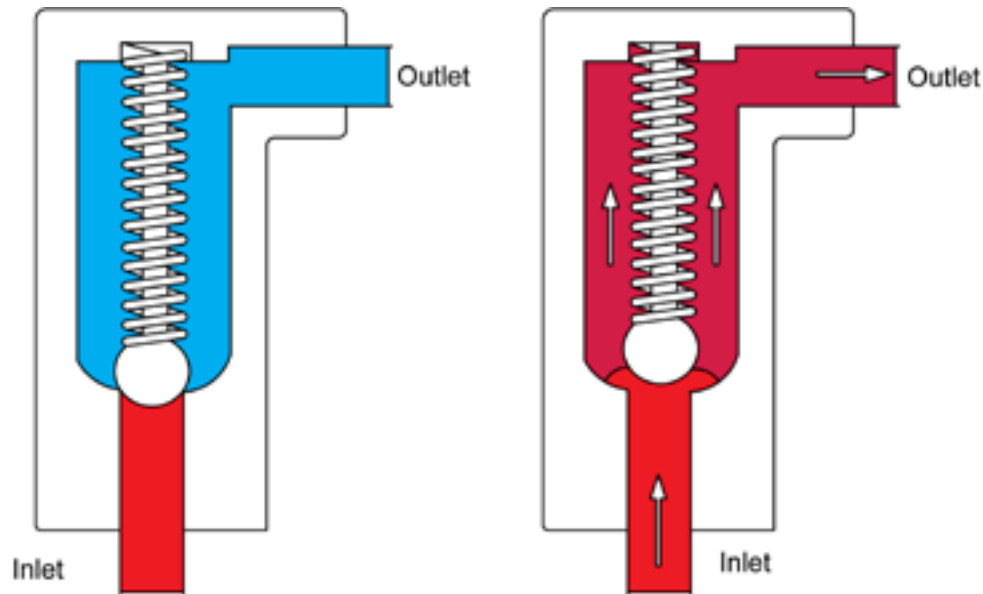

Poppet" is a term for the working part of the valve. Ball poppets are most commonly used (though they may "chatter" during frequent operation). Other poppets used are shaped like buttons or like small cones or disks.

Cracking pressure and pressure override

"Cracking pressure" is the pressure at which the relief valve first begins to open. "Full-flow pressure" is the pressure at which the valve passes its full quantity of oil.

Full-flow pressure is quite a bit higher than cracking pressure. This is because the spring tension builds up as the valve opens farther. This condition is called "pressure override" and it is one disadvantage of the simple relief valve.

Direct acting relief valves

These valves are used mainly where volume is low, and for less frequent operations.

They have a fast response, making them ideal for relieving shock pressures.

They are often used as safety valves to prevent damage to components.

Direct acting relief valves also serve as pilot valves for the pilot operated relief valves.

Direct acting relief valves are very simple. If they fail, no harm is usually done. The resulting pressure loss in the system is apparent to the operator and he can replace the broken spring or worn valve or seat.

5.3.2 Pilot operated Relief Valves

When a relief valve is needed for large volumes with little pressure differential, pilot operated relief valve is often used.

a

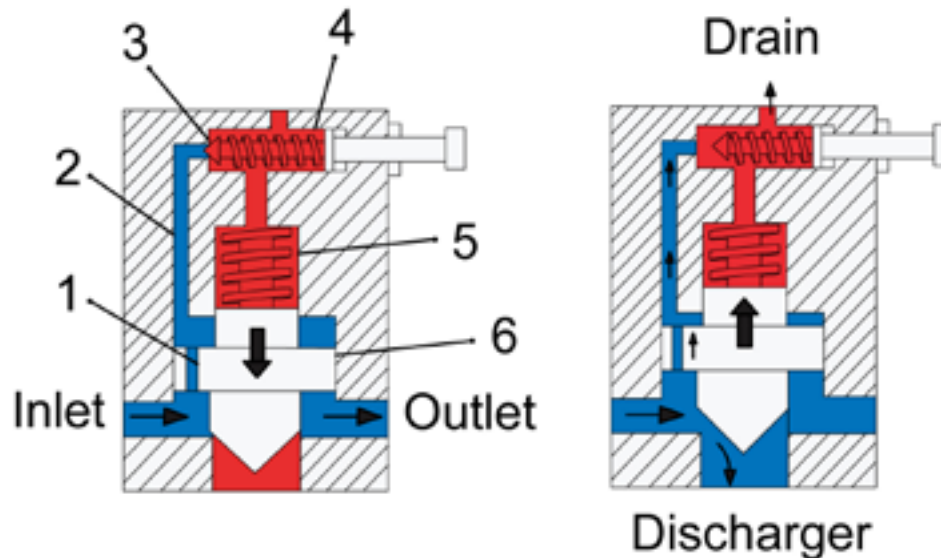

The pilot valve is a "trigger" which controls the main relief valve. It is usually a small, spring-loaded relief valve built into the main relief valve.

The main relief valve is closed when inlet oil pressure is below the valve setting. Passage (1) in the main valve (6) keeps it in hydraulic balance, while spring (5) holds it closed. The pilot valve (3) is also closed at this time. Inlet pressure through sensing passage (2) is less than the pilot valve setting.

As inlet oil pressure rises, pressure in passage (2) also rises. When it reaches the pilot valve setting, the valve (3) is opened. This releases oil behind the main valve through passage (2) and out the drain port. The resulting pressure drop behind the main relief valve (6) causes it to open. Now the main relief operation begins as excess oil is dumped at the discharge port, preventing a further rise in inlet pressure. The valves close again when inlet oil pressure drops below the valve settings.

Pilot operated relief valves have less pressure override than the simple direct acting types. While the direct acting valve starts to open at about half its full-flow pressure, the pilot operated valve opens at about 90 percent of its full-flow pressure.

Because these valves don't start to open until almost full-flow pressure, the efficiency of the system is protected, less oil is released.

5.4 Pressure reducing valves

A pressure-reducing valve is used to keep the pressure in one branch of a circuit below that in the main circuit. When not operating, a pressure reducing valve is open. When it operates, it tends to close as shown.

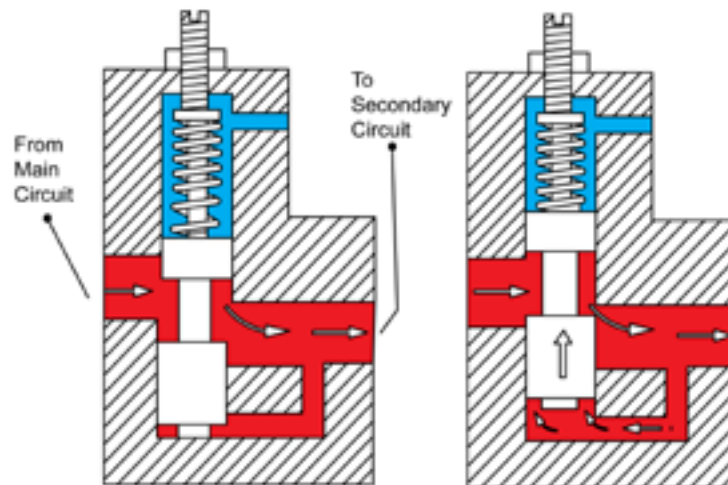

Operation:

When pressure starts to rise in the secondary circuit, force is exerted on the bottom of the valve spool, partly closing it. Spring tension holds the valve against the oil pressure so that only enough oil gets past the valve to serve the secondary circuit at the desired pressure (The spring tension can be adjusted using the screw shown at the top)

The pressure sensing for the valve comes from the outlet side, Or the secondary circuit. This valve operates the reverse of a relief valve, which senses pressure from the inlet and is closed when not operating.

A pressure reducing valve will limit maximum pressures in the secondary circuit, regardless of pressure changes in the main circuit, as long as the system work load does not create back pressure into the reducing valve port. Back pressure would close the valve completely

Types of Pressure Reducing Valves

Pressure reducing valves can operate in two ways:

- Constant Reduced Pressure
- Fixed Amount Reduction

Constant reduced pressure valves supply a fixed pressure regardless of main circuit pressure (so long as it is higher).

Fixed amount reducing valves supply a fixed amount of pressure reduction, which means that it varies with the main circuit pressure.

For example, the valve might be set to give a reduction of 500 psi. If system pressure was 2000 psi, the valve would reduce pressure to 1500 psi. If system pressure dropped to 1500 psi, the valve would reduce pressure to 1000 psi.

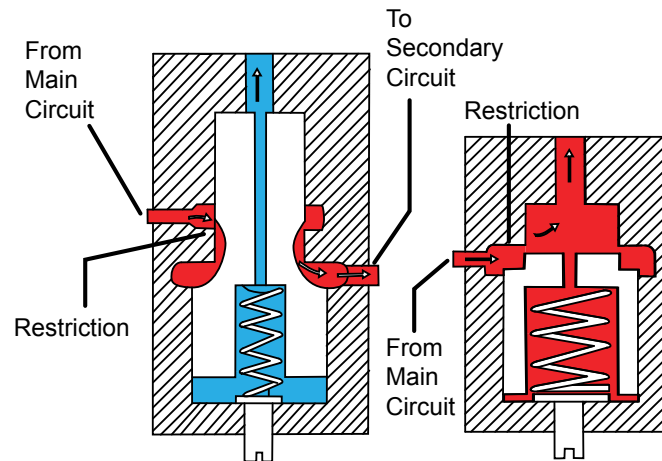

The constant reduced pressure valve operates by balancing the secondary pressure against an adjustable spring which is trying to open the valve. When secondary pressure drops, the spring opens the valve enough to increase pressure and to keep a constant reduced pressure in the secondary circuit.

The fixed amount reduction valve operates by balancing the main circuit pressure coming in against both the secondary pressure at the outlet and the spring pressure. Since the exposed areas of the inlet and outlet sides are equal, the fixed reduction will be that of the spring setting.

5.5 Pilot Operated Types

As with relief valves, a small pilot valve can be added to control a pressure-reducing valve. Operation is the same as described above except that the pilot valve acts first to “trigger” the reducing valve. Using a pilot valve gives a wider range of adjustment and a more consistent relief operation.

5.6 Pressure Sequence Valves

Pressure sequence valves are used to control the sequence of flow to various branches of a circuit. Usually the valves allow flow to a second function only after a first has been fully satisfied

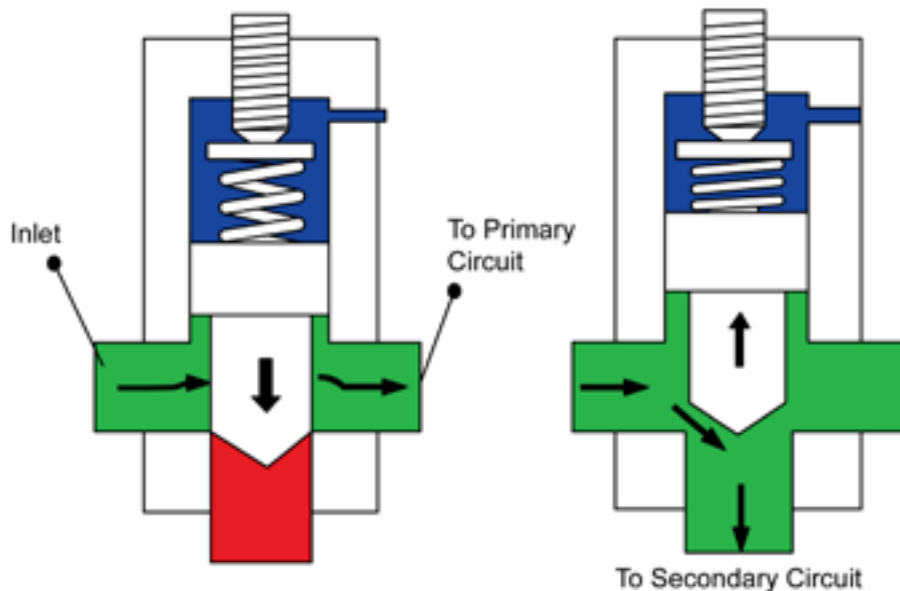

When closed, the valve directs oil freely to the primary circuit.

When opened, the valve diverts oil to a secondary circuit.

The valve opens when pressure oil to the primary reaches a preset point (adjustable at the valve spring). The valve is then lifted off its seat as shown and oil can flow through the lower port to the secondary.

One use of the sequence valve is to regulate the operating sequence of two separate cylinders. The second cylinder begins its stroke when the first completes its stroke. Here the sequence valve keeps pressure on the first cylinder during the operation of the second.

Sequence valves sometimes have check valves which allow a reverse free flow from the secondary to the primary, but sequencing action is provided only when the flow is from primary to secondary.

5.7 Unloading valves

The unloading valve directs pump output oil back to reservoir at low pressure after system pressure has been reached. They may be installed in the pump outlet line with a tee connection.

In some hydraulic systems pump flow may not be needed during part of the cycle. If pump output has to flow through a relief valve at system pressure, much hydraulic energy is wasted as heat. This is where an unloading valve works best.

When closed, spring pressure holds the valve on its seat. Sensing pressure at the other end of the valve is less than spring pressure. The reservoir outlet is closed and no unloading occurs.

The valve opens when the sensing pressure rises and overcomes the spring thrust.

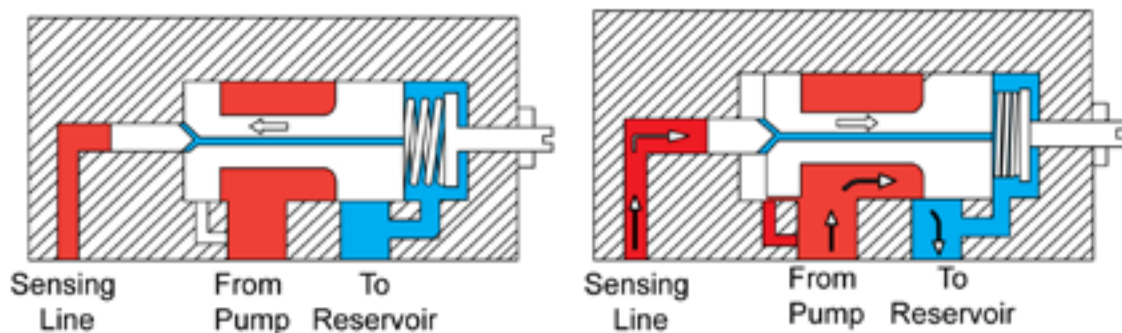

The valve moves back, opening the outlet to the reservoir. Pump output oil is now diverted to the reservoir at low pressure.

5.8 Unloading Valves for Accumulator Circuits

An unloading valve is often used in an accumulator circuit to unload the pump after the accumulator is charged.

The valve is closed while the pump charges the accumulator with oil. As the pressure rises it forces the small sensing piston against the large valve and compresses the spring.

When accumulator pressure reaches that determined by the spring setting, the valve opens by passing oil and relieving the pump. At this time the low neutral pressure oil is directed to the large end of the large piston.

When the accumulator discharges and the system pressure drops, the spring moved the

valve against the reduced system pressure in the small piston and the neutral pressure against the large end of the valve.

This means the valve will close at a slightly lower pressure than it opens. This gives the valve an operating range and prevents chattering.

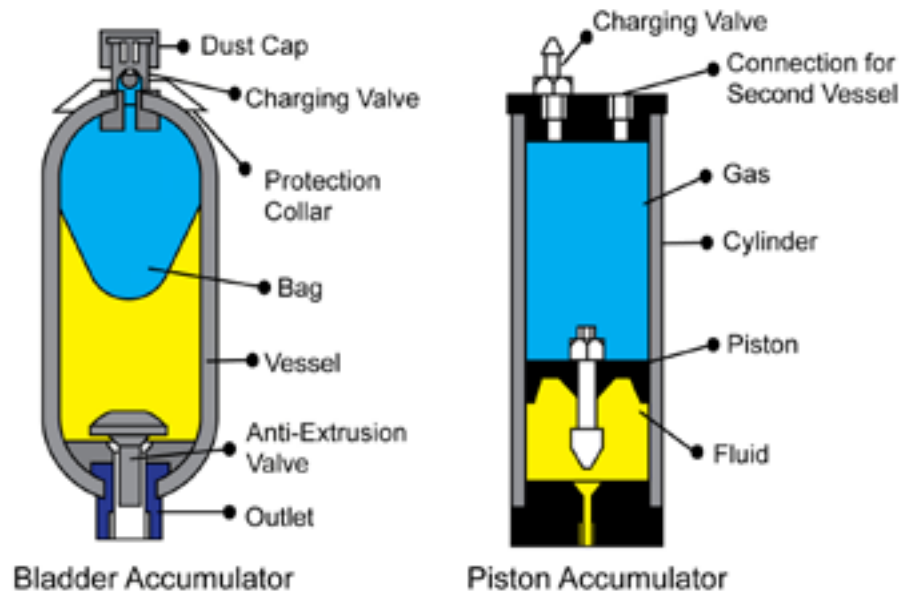

6. Hydraulic cylinders

6.1 Introduction

The cylinder does the work of the hydraulic system. It converts the fluid power from the pump back to mechanical power. Cylinders are the “arms” of the hydraulic circuit.

Module Basic Hydraulics explains the uses of hydraulics and shows how cylinders can be used to actuate both mounted equipment and drawn implements (remote uses). In either case, the basic design of the cylinder is the same: only the extra features are different.

Types of cylinders

Two major types of cylinders are covered in this chapter:

- Single acting cylinders
- Double acting cylinders

Single acting cylinders - give force only one way. Pressure oil is admitted to only one end of the cylinder, raising the load. An outside force such as gravity or a spring must return the cylinder to its starting point.

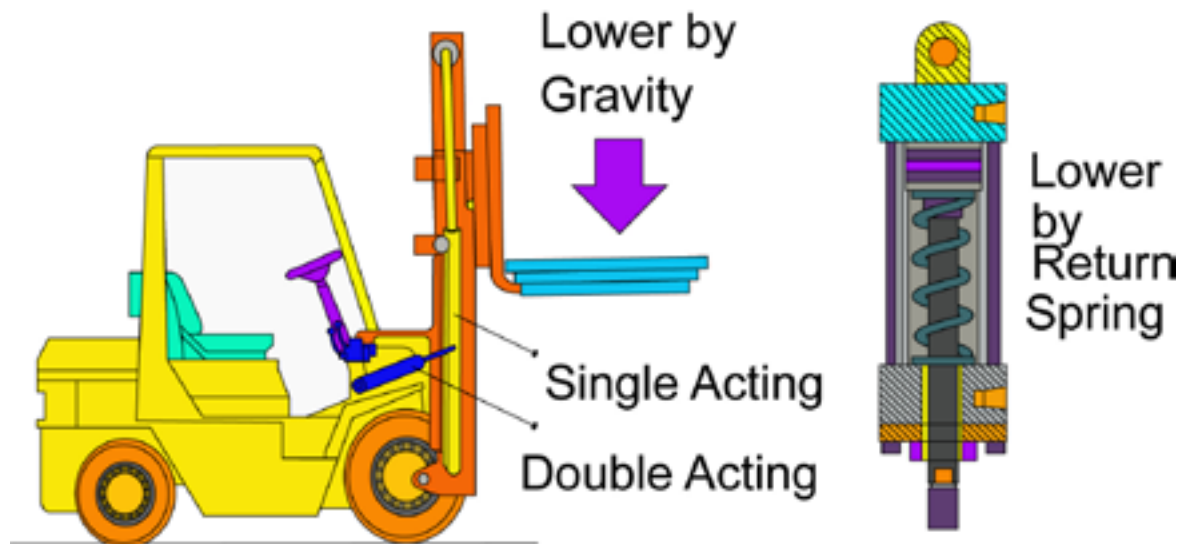

Oil in the cylinder is needed for lifting the forks of a forklift. Lowering the forks is done by its own weight (gravity force). Some single acting cylinders are extended by using oil, and retracting is done by the use of a coil spring.

Double acting cylinders - give force in both directions. Pressure oil is admitted first at one end of the cylinder, then at the other, giving two-way power.

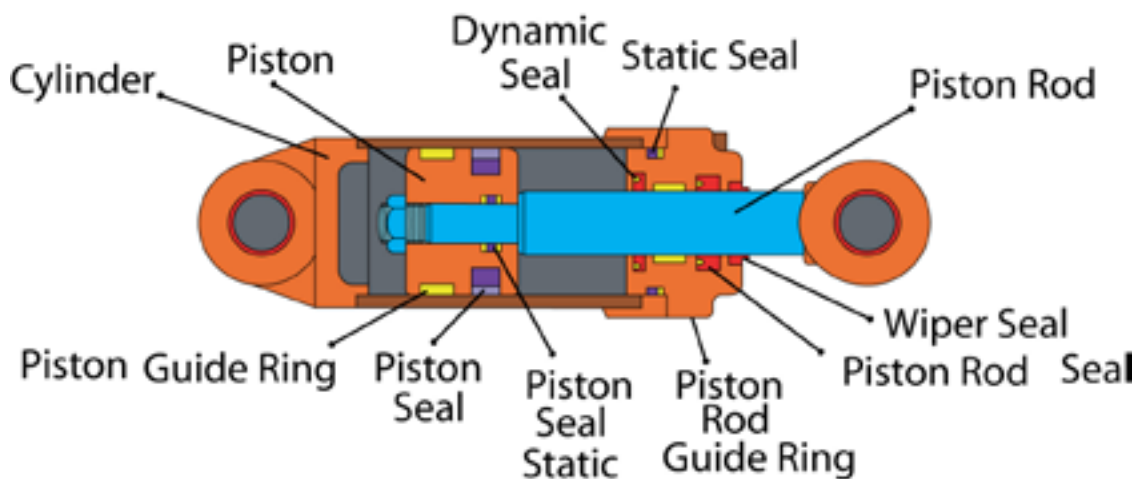

In both types of cylinders, a movable piston (or rod) slides in a cylinder housing or barrel in response to pressure oil admitted to the cylinder. The piston may use various packings or seals to prevent leakage.

A seal on the piston prevents leakage of oil into the dry side of the cylinder. A wiper seal in the rod end of the cylinder cleans the rod as it moves in and out of the housing. In some single-acting cylinders, the piston rod has no piston on the inner end. Instead, the end of the rod serves as the piston. This is called a ram-type cylinder.

The rod is slightly smaller than the inside of the cylinder. (A small shoulder or ring on the end of the rod keeps the rod from being pushed out of the cylinder.)

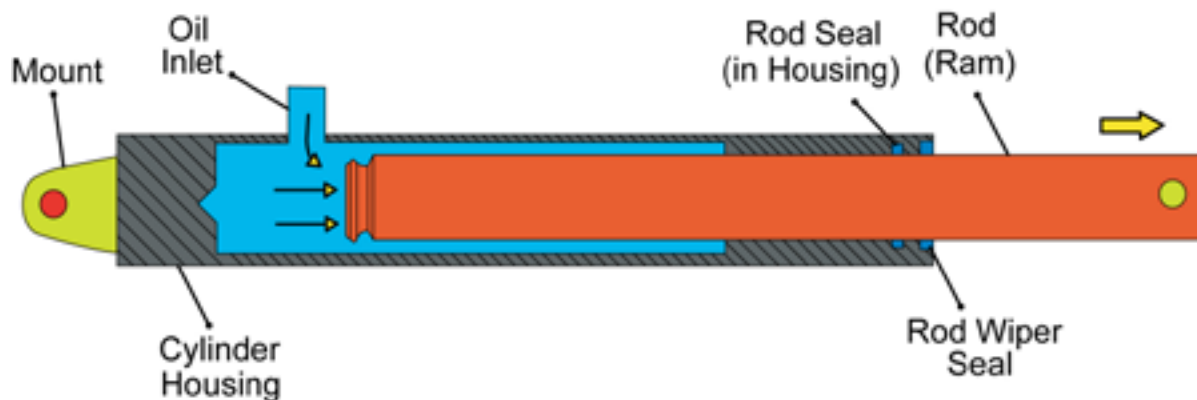

The ram-type construction has several advantages over the piston-type:

- 1) The rod is bigger and resists bending due to side loads.
- 2) The packing is on the outside and is easier to reach.
- 3) Scoring inside the cylinder bore will not damage packings.
- 4) No air vent is needed since oil fills the whole inner chamber of the cylinder housing.

6.2 Double acting cylinders

Double-acting Cylinders provide force in both directions. Pressure oil enters at one end of the cylinder to extend it, at the other to retract it. Oil from the opposite end of the cylinder returns to reservoir each time.

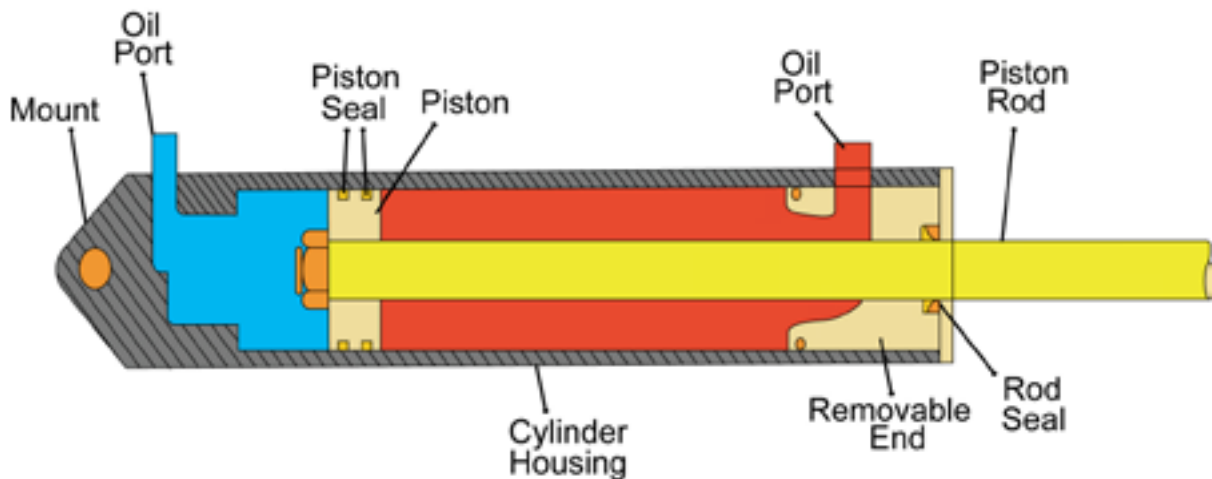

With the double-acting cylinder, both the piston head and the piston rod must be sealed to prevent oil leakage.

Two types of double-acting cylinders:

In the UNBALANCED or differential type, total force on the rod side of the piston is less than that on the blank side. This is because the rod fills in an area not exposed to pressure. This cylinder is usually designed for a slower, more powerful stroke when it extends, and for a faster, less powerful stroke when it retracts.

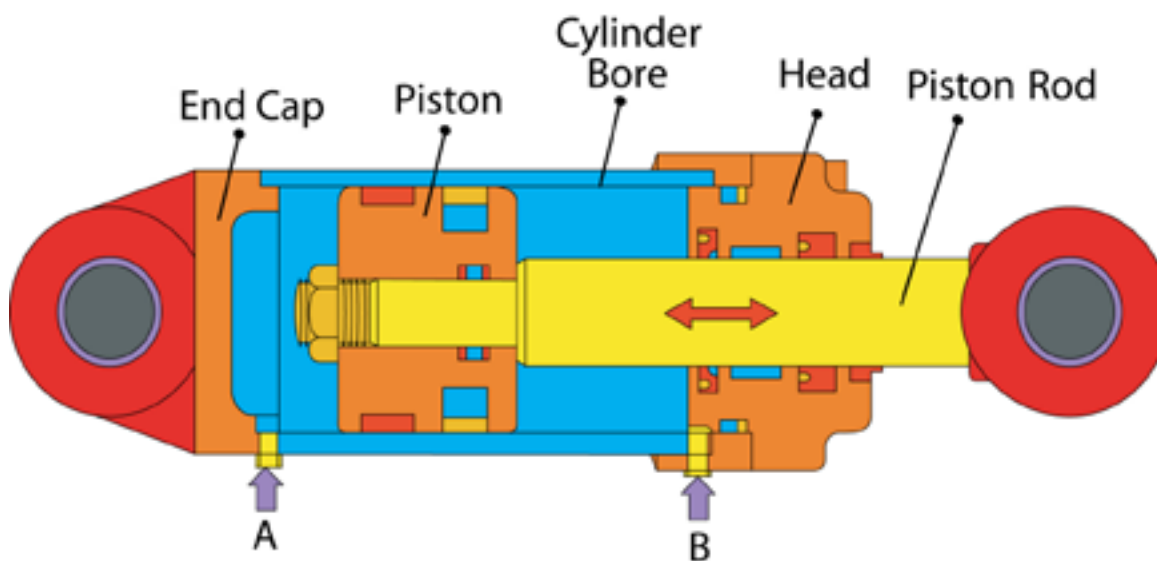

In the BALANCED cylinder, the piston rod extends through the piston head on both sides. This gives equal working area on both sides of the piston and balances the working force of the cylinder whether it is extending or retracting.

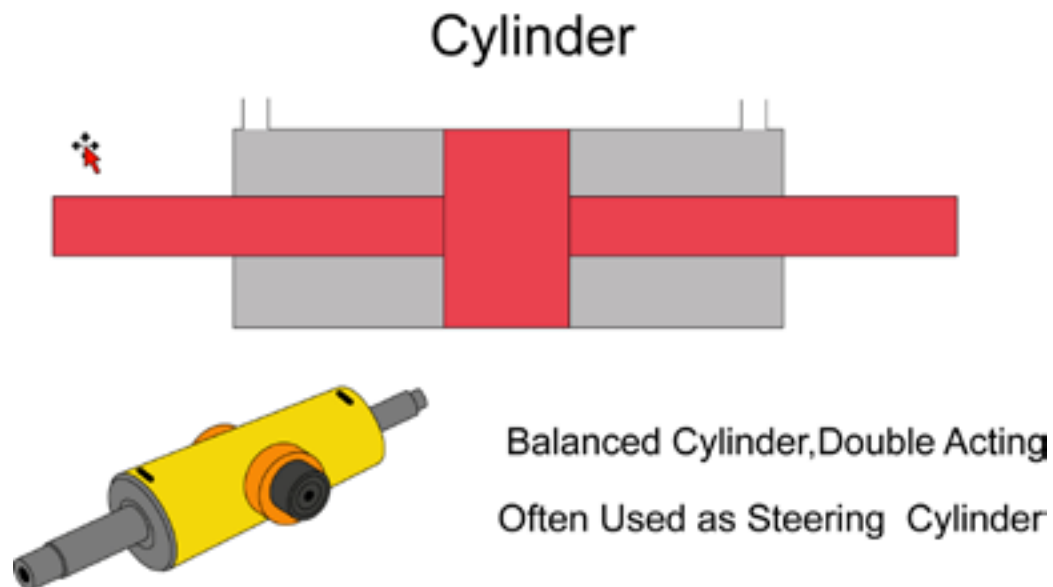

Forklifts and mobile excavators are equipped with a balanced type of double acting cylinder.

6.3 Cushions (hydraulic buffer)

A cushion is built into some cylinders to slow them down at the end of their strokes. This cushion is used as a "hydraulic brake" to protect against impact damage.

The cylinder works normally during its main stroke (top), but slows down as the piston seals off the oil outlet (bottom). Now the outlet oil must go through the small orifice, slowing the piston.

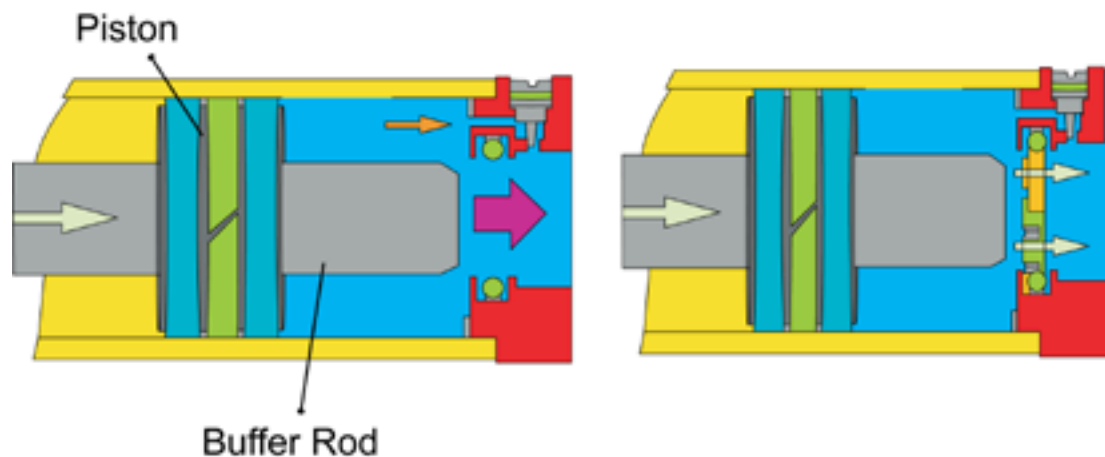

TESTING AND DIAGNOSING CYLINDER PROBLEMS

Cylinders can be tested on the machine for leaks and other failures. The following section on "Maintenance of Cylinders" covers a few of the common problems.

6.4 Maintenance of Cylinders

Hydraulic Cylinders are compact and relatively simple.

The key points to watch are the seals and the pivots. Here are a few service tips:

1. **EXTERNAL LEAKAGE** - If the cylinder end caps are leaking, tighten the caps. If this fails to stop the leak, replace the gasket. If the cylinder leaks around the piston rod, replace the packing. Be sure the seal lip faces toward the pressure oil. If the seal continues to leak, check items 5 through 9 below.
2. **INTERNAL LEAKAGE** - Leakage past the piston seals inside the cylinder can cause sluggish movement or settling under load. Piston leakage can be caused by worn piston seals or rings, or scored cylinder walls. The latter may be caused by dirt and grit in the oil.

IMPORTANT: When repairing a cylinder, be sure to replace all seals and packings before re-assembly.

3. **CREEPING OF CYLINDER** - If the cylinder creeps when stopped in midstroke, check for internal leakage (item 2). Another cause could be a worn control.
4. **SLUGGISH OPERATION** - Air in the cylinder is the most common cause of sluggish action. (To bleed air, see end of this chapter). Internal leakage in the cylinder is another cause (item 2). If action is sluggish when starting up the system, but speeds up when the system is warm, check for oil of too-high viscosity (see machine operator's manual). If the cylinder is still sluggish after these checks, the whole circuit should be tested for worn components.
5. **LOOSE MOUNTING** - Pivot points and mounts may be loose. The bolts or pins may need to be tightened or they may be worn out.

Too much "slop" or "float" in the cylinder mountings damages the piston rod seals. Check all cylinders for loose mountings periodically.

6. **MISALIGNMENT** - Piston rods must work in line at all times. If they are "side loaded," the piston rods will be galled and the packings will be damaged, causing leaks. Eventually the piston rods may be bent or the welds broken.

7. **LACK OF LUBRICATION** - Lack of piston rod lubrication may cause the rod packing to seize, resulting in an erratic stroke, especially on single-acting cylinders.
8. **ABRASIVES ON PISTON ROD** - When piston rods extend, they can pick up dirt and other material. Then when the rod retracts, it carries the grit into the cylinder, damaging the rod seal. This is why rod wipers are often used at the rod end of the cylinder to clean the rod as it retracts. Rubber boots are also used over the end of the cylinder in some cases. Another problem is rusting of piston rods. When storing cylinders, always retract the piston rods to protect them.
9. **BURRS ON PISTON ROD** - Exposed piston rods can be damaged by impact with hard objects. If the smooth surface of the rod is marred, the rod seal may be damaged. Burrs on the rod should be cleaned up immediately using crocus cloth.
10. **CHECKING AIR VENTS** - Single-acting cylinders (except ram-types) must have an air vent in the dry side of the cylinder. To prevent dirt entry, various filter devices are used. Most are self-cleaning, but they should be inspected periodically to insure proper operation.

6.5 Bleeding Air from Remote Cylinders

Any time a remote cylinder is plugged in the hydraulic circuit, all trapped air must be bled. This will prevent sluggish action of the cylinder.

First attach the cylinder to the circuit. While standing to the side of the machine, place the cylinder on the ground (or on a hanger) with the piston rod end down. (Or on mounted cylinders, place the head end of the cylinder in its working mount, allowing the rod end freedom to move in and out.) Have someone else start the machine and move the hydraulic control lever back and forth seven or eight times to extend and retract the cylinder. This will bleed the air. (On double-acting cylinders, you may have to turn the cylinder end-for-end and repeat the cycling of the control lever.)



6.6 Caution

Long reach digger arm cylinders can get easily damaged.

With an external force acting on the digger arm, the force acting on the digger arm can cause the digger arm, hydraulic cylinder to crack near the joint where the cylinder head is welded onto the cylinder.

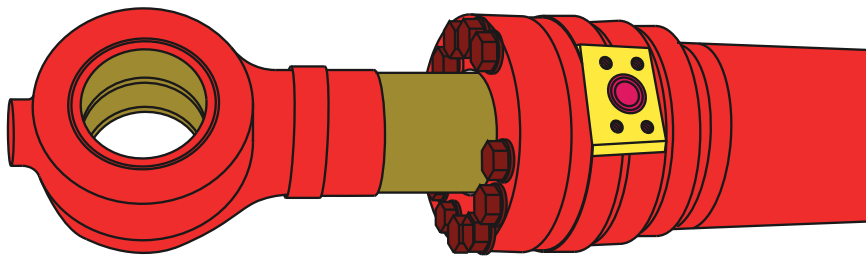

6.7 Basic Hydraulic System

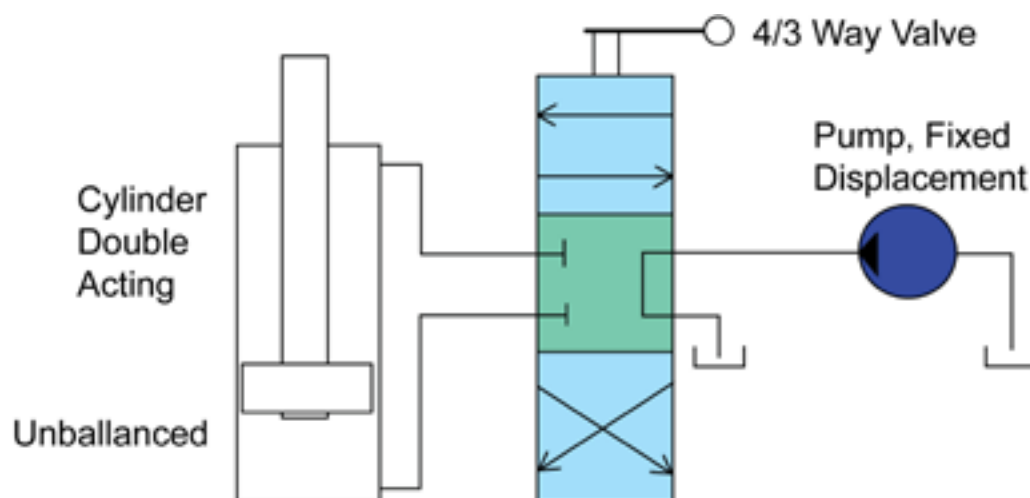
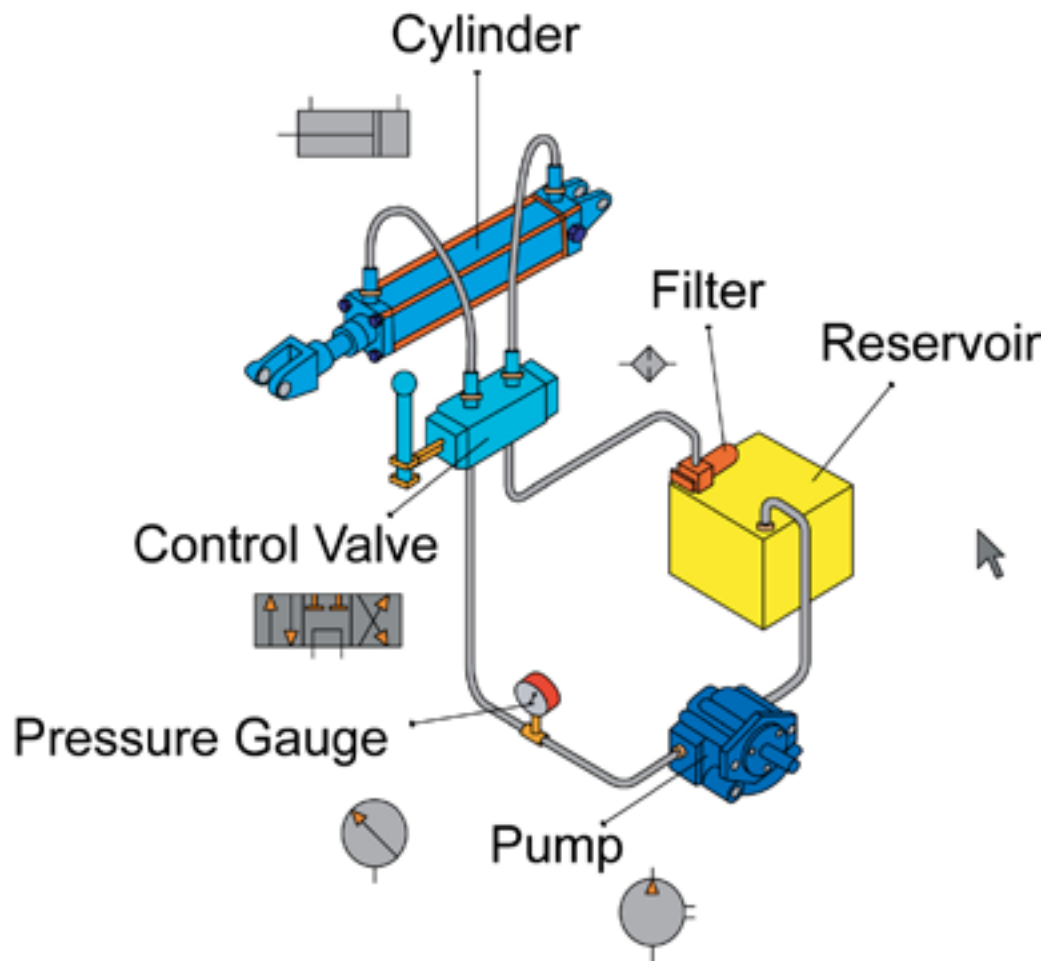

7. Hydraulic accumulators

7.1 Introduction

A spring is the simplest accumulator.

When compressed, a spring becomes a source of potential energy.

It can also be used to absorb shocks or to control the force on a load.

Hydraulic accumulators work in much the same way.

Basically they are containers which store fluid under pressure.

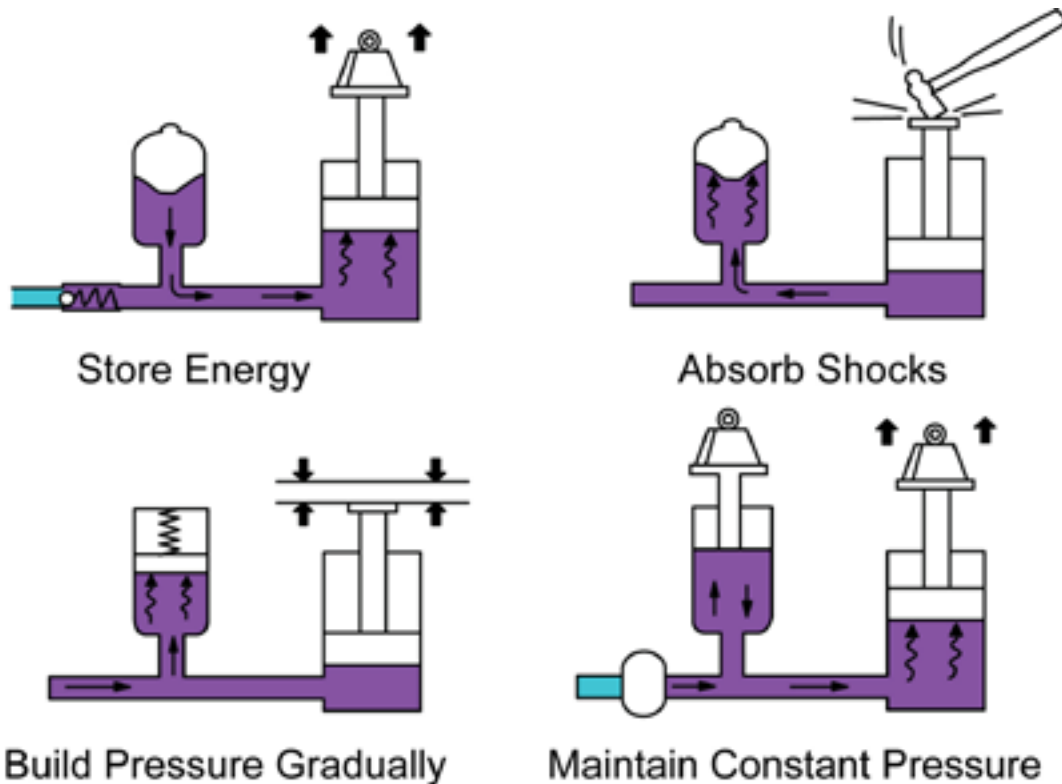

Accumulators have four major functions

- Store Energy
- Absorb Shocks
- Build Pressure Gradually
- Maintain Constant Pressure



While most accumulators can do any of these things, their use in a system is usually limited to only one.

Accumulators which store energy are often used as “boosters” for systems with fixed displacement pumps. The accumulator stores pressure oil during slack periods and feeds it back into the system during peak periods of oil usage. The pump recharges the accumulator after each peak. Sometimes the accumulator is used as a protection against failure of the oil supply.

Example: power brakes on larger machines. If the system oil supply fails, the accumulator feeds in several “charges” of oil for use in emergency braking.

Accumulators which absorb shocks take in excess oil during peak pressures and let it out again after the “surge” is past. This reduces vibrations and noise in the system.

The accumulator may also smooth out operation during pressure delays, as when a variable displacement pump goes into stroke. By discharging at this moment, the accumulator “takes up the slack.”

Accumulators which build pressure gradually are used to “soften” the working stroke of a piston against a fixed load, as in a hydraulic press. By absorbing some of the rising oil pressure the accumulator slows down the stroke.

Accumulators which maintain constant pressure are always weight-loaded types which place a fixed force on the oil in a closed circuit. Whether the volume of oil changes from leakage or from heat expansion or contraction, this accumulator keeps the same gravity pressure on the system.

The major types of accumulators are:

- Pneumatic (Gas-Loaded) Weight-Loaded
- Spring-Loaded

7.2 Pneumatic accumulators

We learned that fluids will not compress (little), but gases will.

For this reason, many accumulators use inert gas as a way of “charging” a load of oil or of providing a “cushion” against shocks.

“Pneumatic” means operated by compressed gas. In these accumulators, gas and oil occupy the same container. When the oil pressure rises, incoming oil compresses the gas. When oil pressure drops, the gas expands, forcing out oil.

In most cases, the gas is separated from the oil by a piston, a bladder, or a diaphragm. This prevents mixing of the gas and oil and keeps gas out of the hydraulic system.

7.3 Bladder type accumulators

A flexible bag or bladder made of synthetic rubber contains the gas and separates it from the hydraulic oil. The bladder is molded to the gas charging stem located at the top of the accumulator.

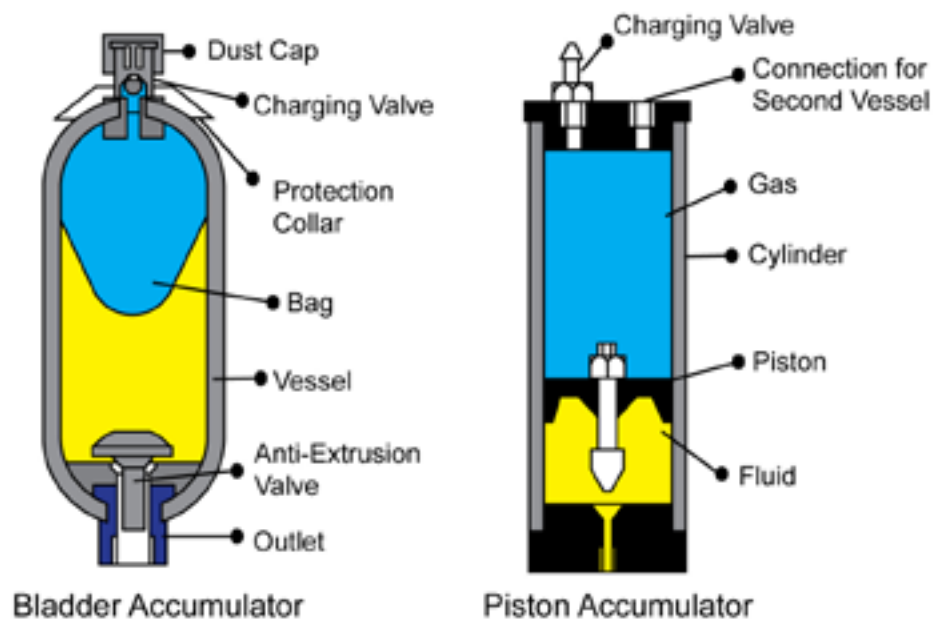

To prevent damage to the bladder, a protective button is used at the bottom. This button prevents the bladder from being drawn into the oil port when the bladder expands. Otherwise, the bladder might be cut or torn.

Bladder-type accumulators can also be pre-charged before use.

All hydraulic earthmoving machines are using accumulators.

To cushion the main boom when traveling (mobile excavator) or as a suspension system on dump trucks and off-high-way trucks.

But also the Servo system is using accumulator to absorb shock loads when operating the main control valve. It also allows the main boom to lower safely to the ground, in case of engine failure (not running).

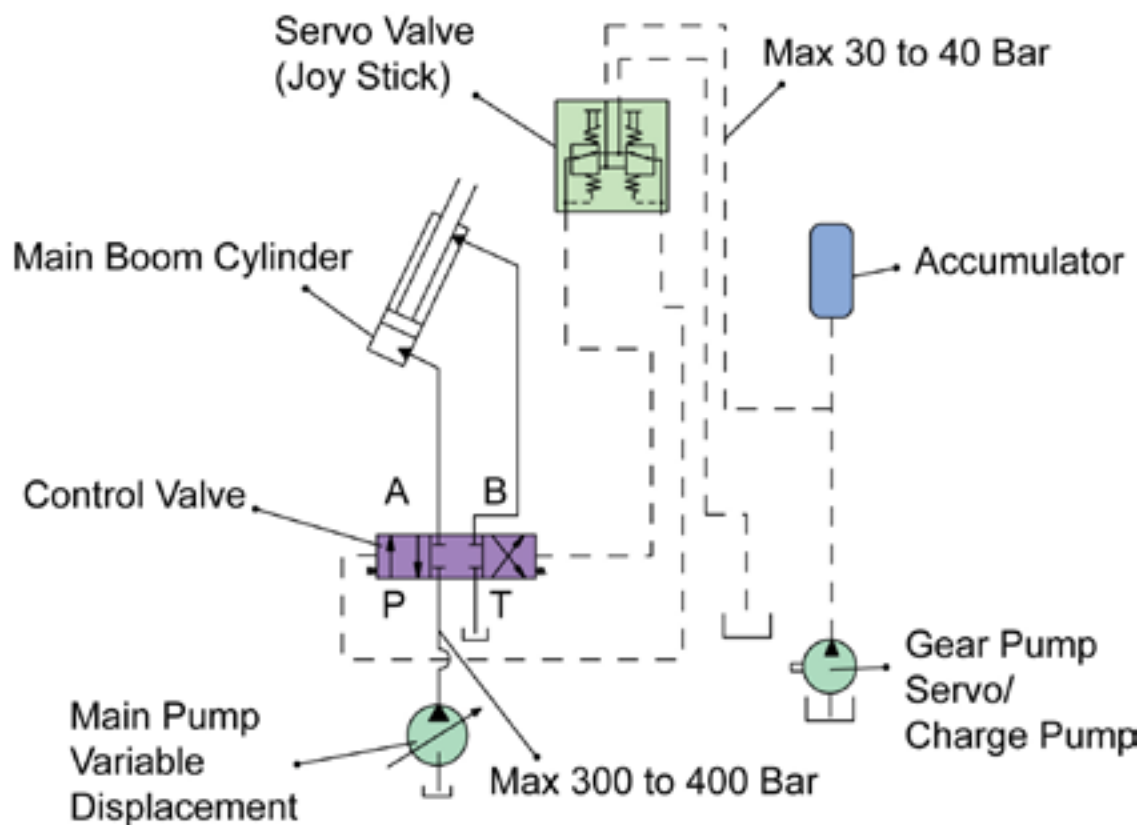

7.4 Precautions

Observe the following precautions when working on pneumatic accumulators. The correct procedures for service are given in detail later under "Servicing and Pre-charging Pneumatic Accumulators."

1. **CAUTION: NEVER FILL AN ACCUMULATOR WITH OXYGEN!**
An explosion could result if oil and oxygen mix under pressure.
2. Never fill an accumulator with air. When air is compressed, water vapor in the air condenses and can cause rust. This in turn may damage seals and ruin the accumulator. Also, once air leaks into the oil, the oil becomes oxidized and breaks down.
3. Always fill an accumulator with an *inert gas* such as *dry nitrogen*. This gas is free of both water vapor and oxygen: this makes it harmless to parts and safe to use.
4. Never charge an accumulator to a pressure more than that recommended by the manufacturer. Read the label and observe the "working pressure."
5. Before removing an accumulator from a hydraulic system, *release all hydraulic pressure*.
6. Before you disassemble an accumulator, release both gas and hydraulic pressures.
7. When you disassemble an accumulator, make sure that dirt and abrasive material does not enter any of the openings.

7.4.1 Checking Precharged Accumulator on the Machine

1. If you suspect external gas leaks, apply soapy water to the gas valve and seams on the tank at the "gas" end. If bubbles form, there is a leak.
2. If you suspect internal leaks, check for foaming oil in the system reservoir and/or no action of the accumulator. These signs usually mean a faulty bladder or piston seals inside the accumulator.
3. If the accumulator appears to be in good condition but is still slow or inactive, pre-charge it as necessary.

7.4.2 Before Removing Accumulator from Machine

First be sure all hydraulic pressure is released

To do this, shut down the pump and cycle some mechanism in the accumulator hydraulic circuit to relieve oil pressure (or open a bleed screw).

REMOVING ACCUMULATOR FROM MACHINE

After all hydraulic pressure has been released, remove the accumulator from the machine for service.

7.4.3 Repairing Accumulator

1. Before dismantling accumulator, release all gas pressure. Normally unscrew the gas valve lever very slowly. Install the charging valve first if necessary. Never release the gas by depressing the valve core, as the core might be ruptured.
2. Disassemble the accumulator on a clean bench area.
3. Check all parts for leaks or other damage.
4. Plug the openings with plastic plugs or
5. clean towels as soon as parts are removed.
6. Check bladder or piston seals for damage and replace if necessary.
7. If gas valve cores are replaced, be sure to use the recommended types.
8. Carefully assemble the accumulator.

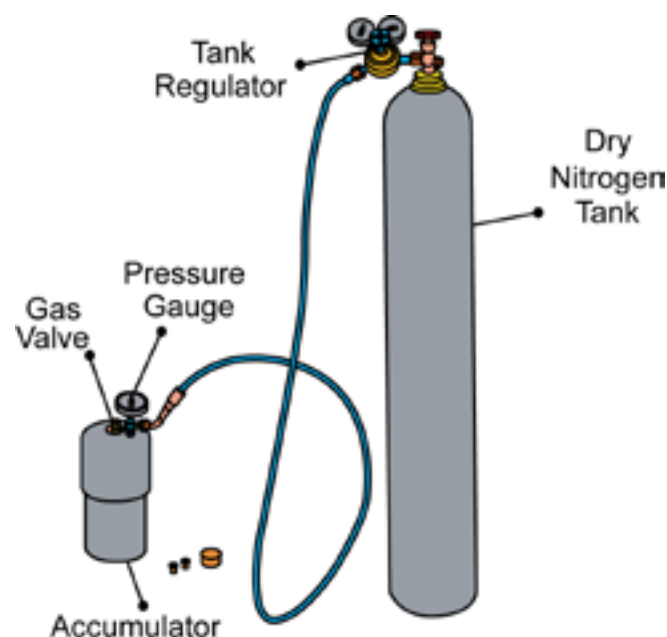

7.4.4 Precharging Accumulator

the hose from a Dry Nitrogen tank to the charging valve of the accumulator and open the accumulator charging valve.

Open the valve on the regulator very slowly until pressure on gauge is same as that recommended by the manufacturer. Close the charging valve on the accumulator, then close the valve on the regulator. Remove hose from charging valve.

NOTE: When checking pre-charge on an accumulator installed on a machine, first release hydraulic pressure from the accumulator. Otherwise you will not get a true pressure reading.

7.4.5 Installing Accumulator on Machine

Attach accumulator to machine and connect all lines. Start machine and cycle a hydraulic function to bleed any air from the system. Then check the accumulator for proper action.

7.5 New Developments

Manufactures of heavy equipment are busy making their machines more environmental friendly. This new system is called Hydraulic hybrid operated. Accumulators will store energy form the driveline when driven by the engine, and feed the accumulators when braking the vehicle. On excavators lifting booms and swing are also available into a hydride version.

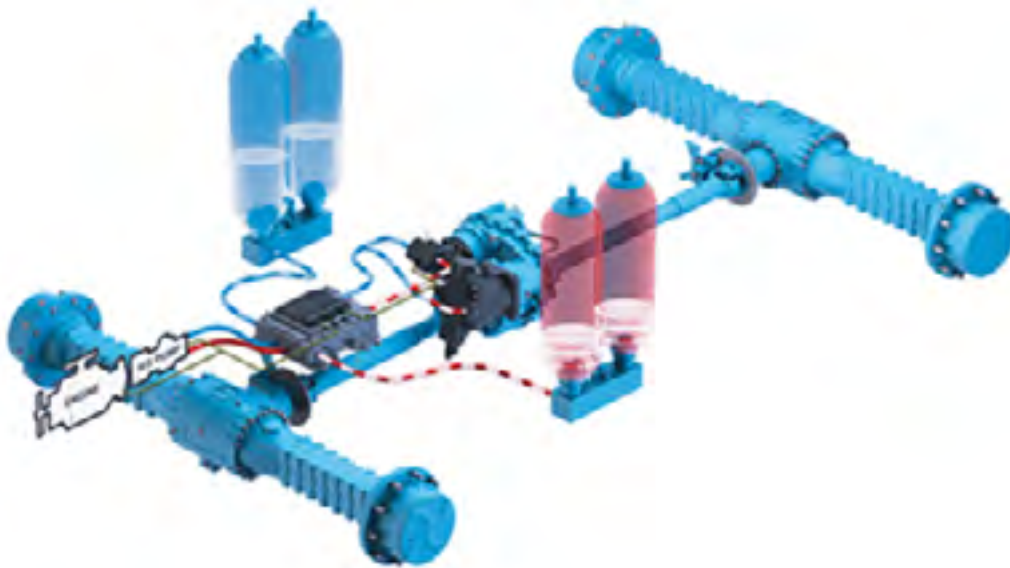

Just visit the Internet for more information regarding this subject.

8. Practical Exercise

1) Refer to the appropriate manual and complete Questions A, B and C

a) Draw the symbol for the following

Vented Reservoir	
Pressurized Reservoir	
Return line above the oil level	
Suction / Return line below the oil level	
Reservoir with suction line attached at the bottom	
Lines, Tubes and Hoses	
Pump	
Oil flow one way only	
Oil can flow either way	
Variable displacement pump	

Non Reversible motor	
Reversible motor	
Single acting cylinder	
Double acting cylinder	
Double rod end cylinder	
Normally closed relief valve	
Normally open relief valve	
Pressure reducing valve	
One Way valve	
By Pass valve	

b) Write short notes on the following symbols

c) Discuss the given simple schematics and write down the function of valve A, B, C and D

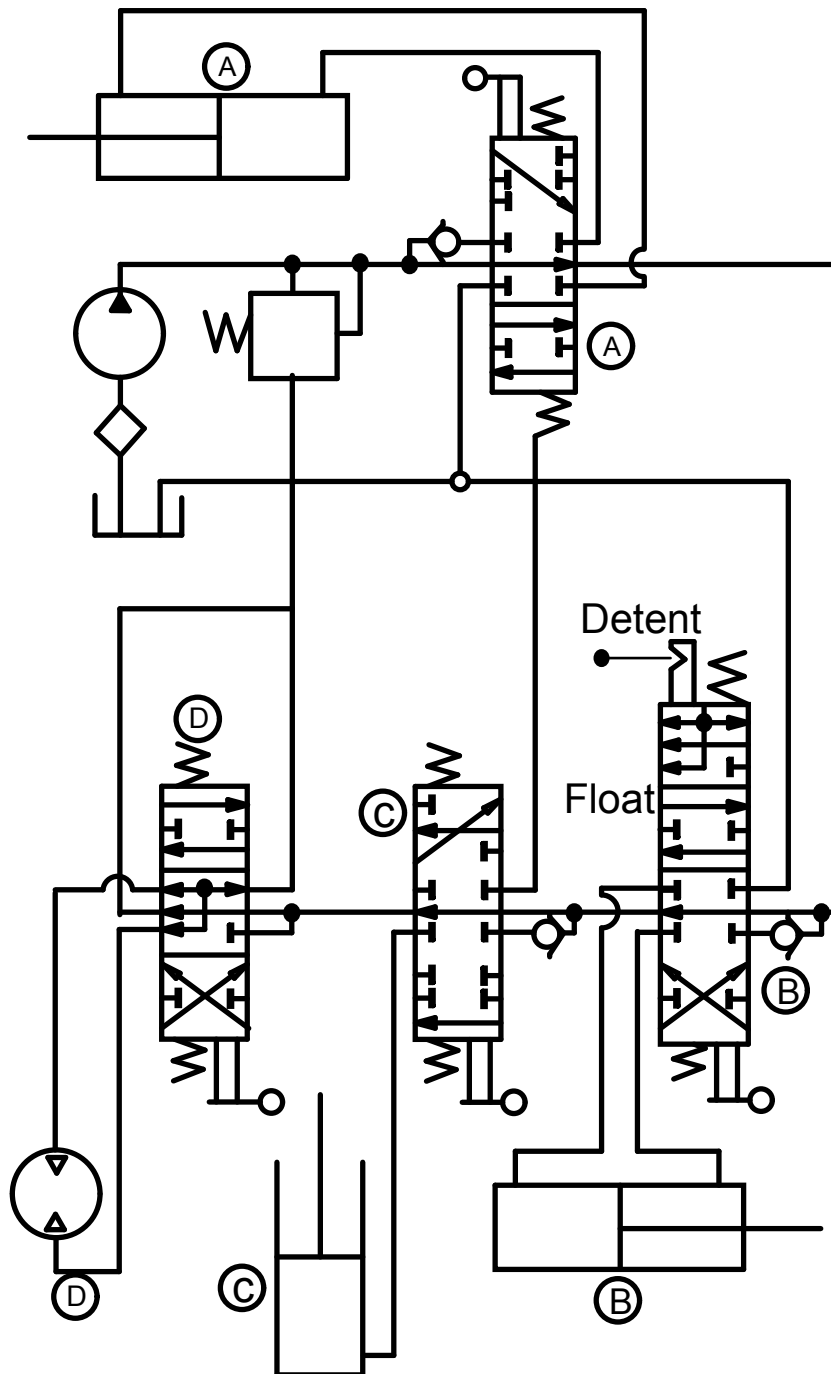

Valve A:

Valve B:

Valve C:

Valve D:

2) On the test bench, build the shown hydraulic circuit and observe its operation

a)

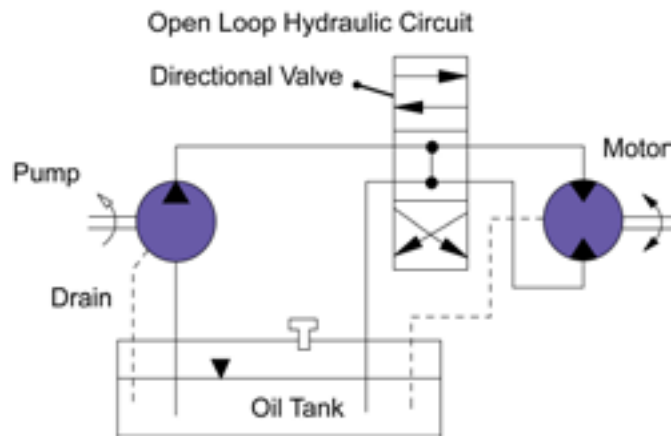

Notes:

b)

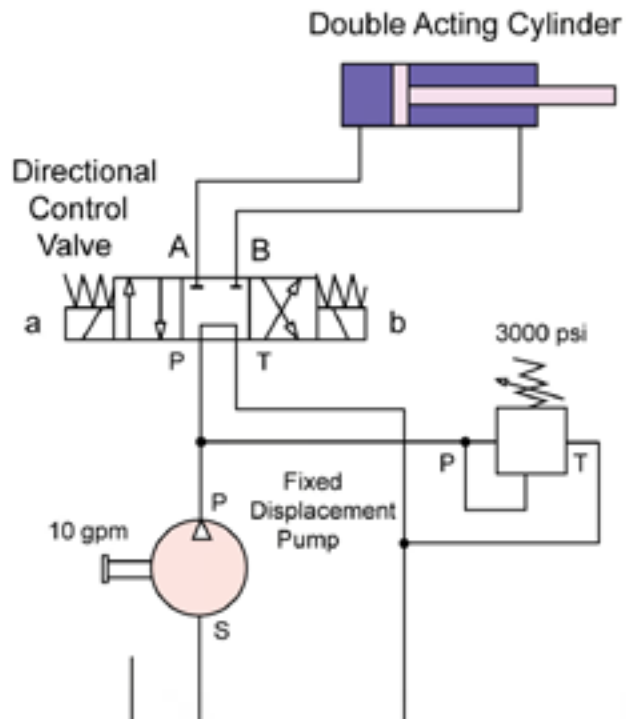

Notes:

3) Refer to the appropriate manual and conduct Inspection and Adjustment of the following hydraulic pressure Inspection and Adjustment in actual machinery by following all the precautions and sequence prescribed

a) Inspect hydraulic pump pressure

Pressure at idle rpm	
Pressure at 1000 rpm	
Pressure at 1500 rpm	

b) Inspect and adjust system relief pressure on directional control valve

Pressure before adjustment	
Pressure after adjustment	

c) How will you inspect and adjust pressure reducing valve (PRV)? (select any PRV)

Notes:

d) For the given practical machinery, use appropriate special service tools and conduct various system pressure test and adjustment.

Notes:

Hydraulic cylinder

Inspection and replacement of seals

To prevent possible injury, do not use compressed air for removing the piston and piston rod from the cylinder barrel.

High oil pressures are dangerous.

Hot components can cause burns.

Given a hydraulic cylinder (double acting), you are to carry out the following:

Inspection of piston rod, piston and cylinder barrel

Inspection and replacement of seals:

- 1) Select the correct tools and accessories
- 2) Use the correct workshop manual
- 3) Use a torque wrench, if necessary
- 4) Measure the piston rod for straightness
- 5) Install new oil seals, using the right procedure

CAUTION

Follow all safety recommendations and safe shop practices outlined in the repair manual or the selected cylinder.

Always use tools and equipment that are in good working order.

Use lifting and hoisting equipment capable of safely handling the load.

Remember, that ultimately safety is your own responsibility.

Excavator cylinder

The cylinder that is used to operate the excavator boom or bucket is equipped with a rod stopper, which acts as a cushion only when the cylinder rod is fully retracted (and the bucket is pulled close to the arm). This type of cylinder is shown in the lower drawing.

CAUTION

Vent air from the hydraulic system before disconnecting cylinder piping connections. Use the lever on the reservoir, while the engine is running.

Discharge the hydraulic accumulator and vent residual tank pressure after the engine is shut off.

Pour clean replacement fluid back into the system if excessive fluid is lost.

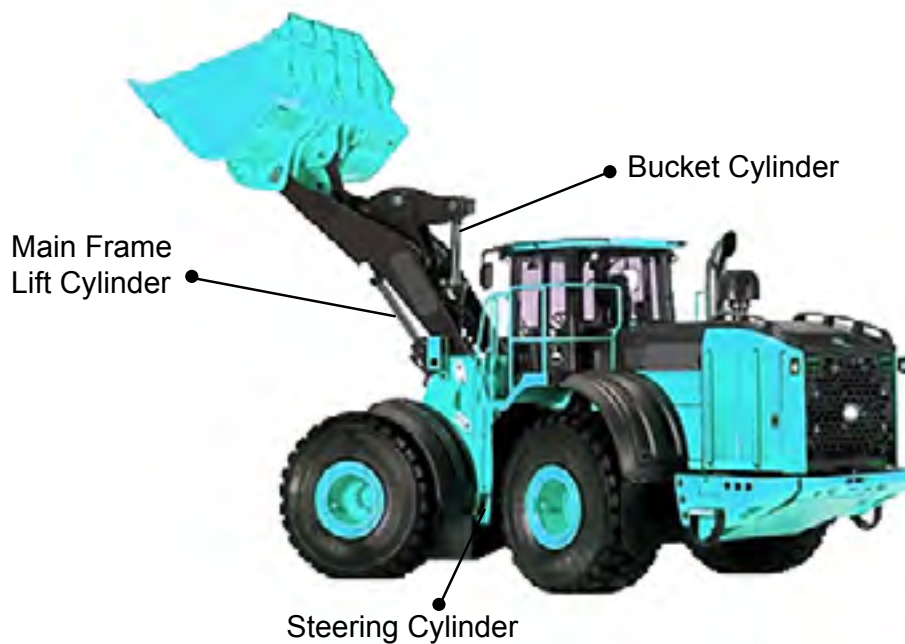
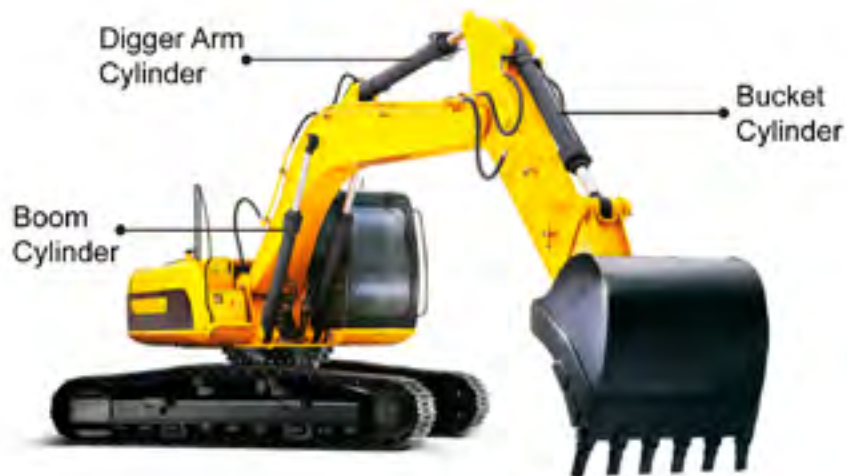

Digger arm cylinder

Arm cylinders have a cushion or stopper for operation in both directions.

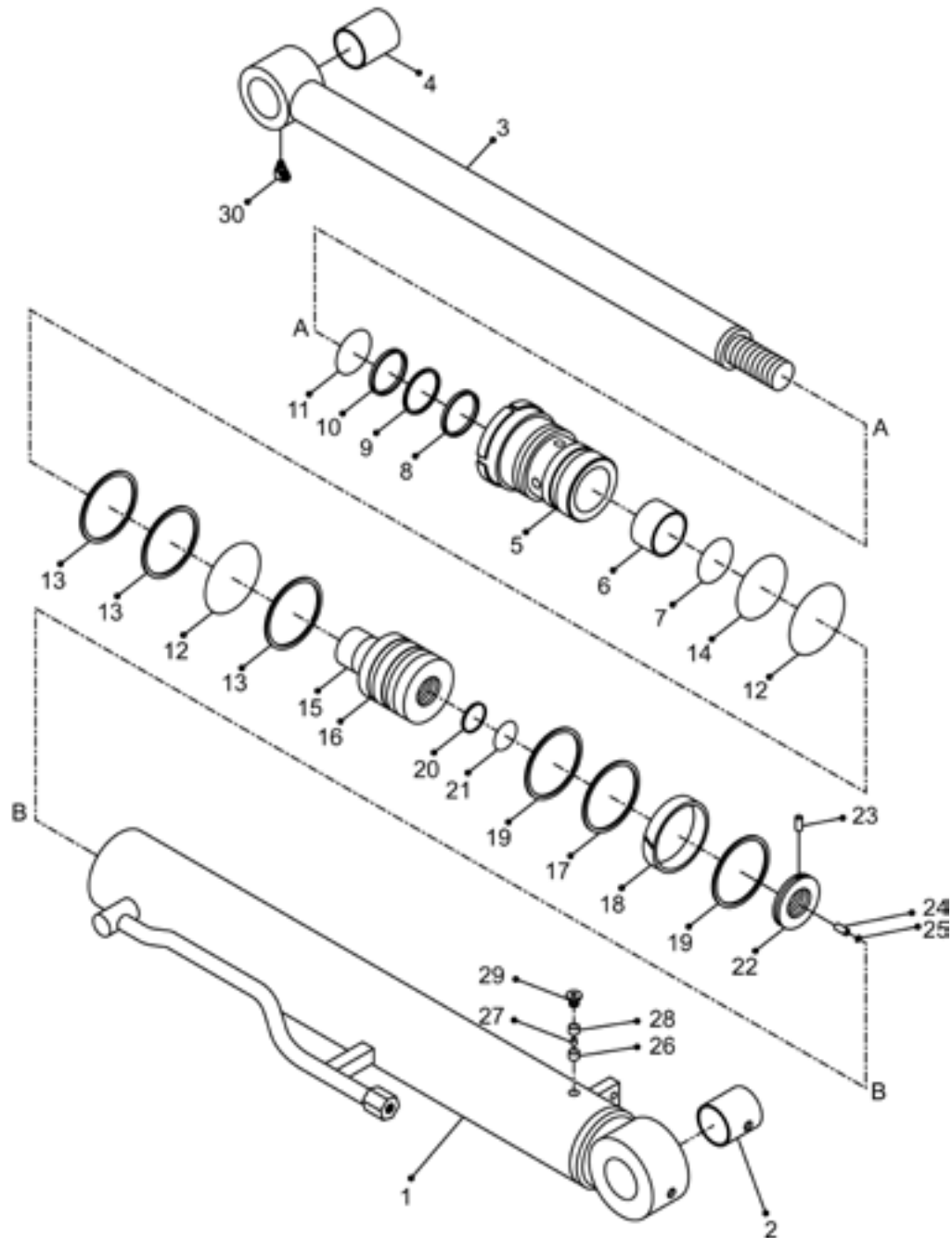

Reference Number:	Description:
1	Tube assembly (cylinder barrel)
2	Bush bearing
3	Rod assembly
4	Bush bearing
5	Rod cover

Digger arm cylinder (continued)

Reference Number:	Description:	Reference Number:	Description:
6	DD-bush	19	Dust ring
7	Retaining ring	20	O-ring
8	Buffer seal	21	Back-up ring
9	U-packing	22	Piston nut
10	Dust wiper	23	Set screw
11	Retaining ring	24	Cushion plunger
12	O-ring	25	Stop ring
13	Back-up ring	26	Check valve
14	O-ring	27	Spring
15	Cushion ring	28	Support spring
16	Piston	29	Hex socket plug
17	Glyd ring	30	Grease nipple
18	Wear ring		

DISASSEMBLY

1. Following removal of cylinder from excavator attachment, support cylinder on some type of sturdy work platform and drain all oil. Rotate cylinder so that piping ports are on top, to allow trapped air to vent.

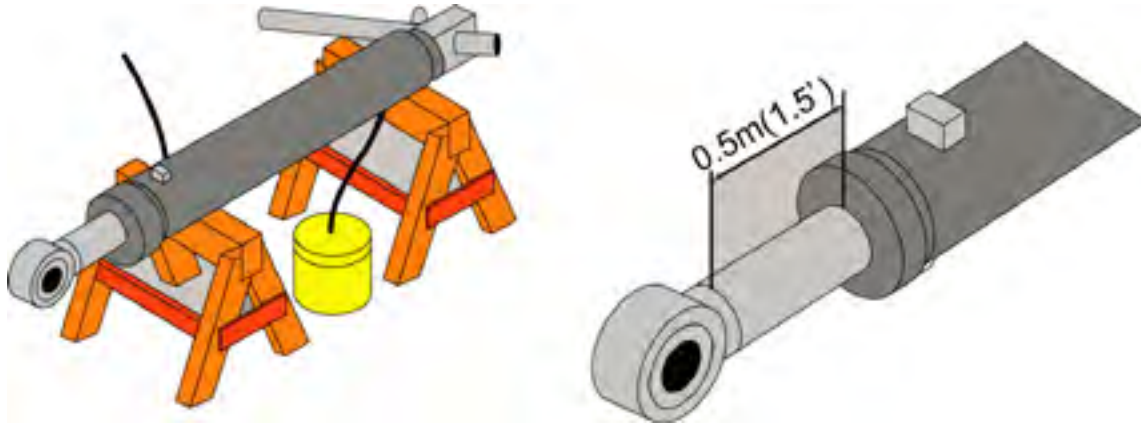

2. Position piston rod so that it is extended approximately one half meter (20").
3. Remove all the bolts on the end of the cylinder.

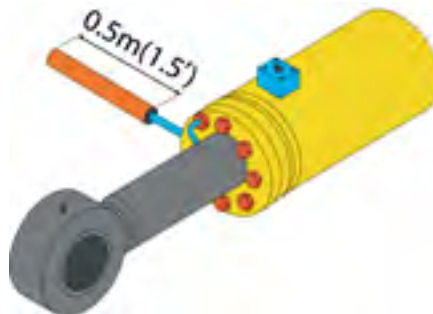

Note: Wrap a cloth or other protective material around the piston rod, to avoid scratching or scoring of the rod surface

4. Tap two bolts into cover of cylinder head, 180° apart. Tighten them in a staggered, even sequence, to back off piston rod end cover from edge of cylinder wall.

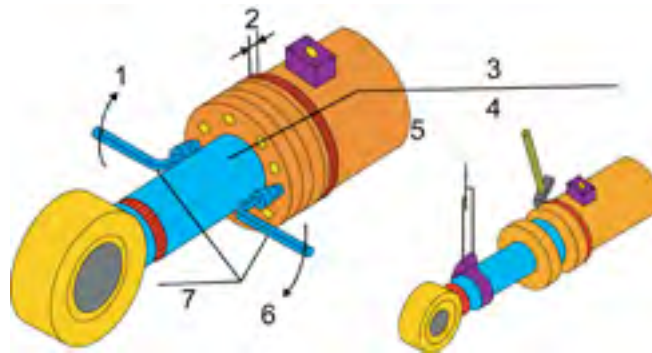

Look for adequate clearance between cover and end of cylinder wall before using a soft-faced hammer for final disassembly.

5. Begin withdrawing piston rod assembly, away from cylinder. Attach a lifting support when final 1/3 of rod is still inside barrel of cylinder. Prepare support blocks for piston rod before it has been completely withdrawn.

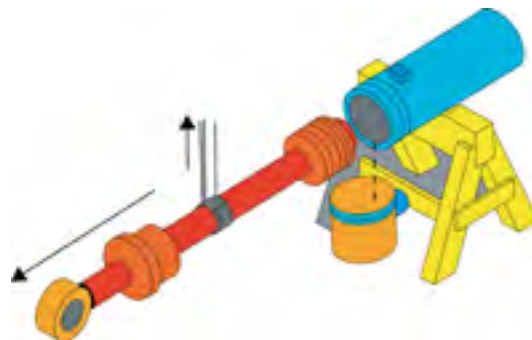

6. Lower piston rod to support blocks and detach wear ring (outer surface) from end of rod.

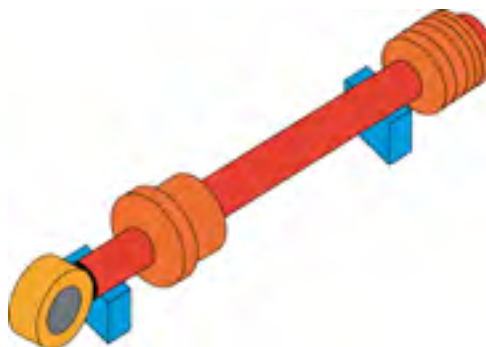

7. Immobilize piston rod by inserting a wooden or other non-scoring, nonmetallic support through end of rod.

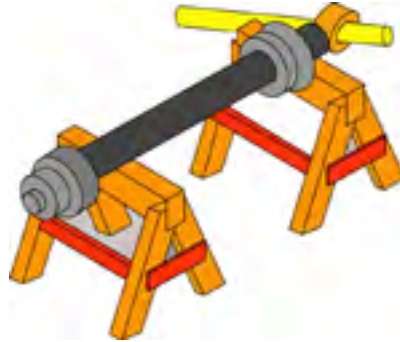

8. Remove set screw by using a socket wrench.

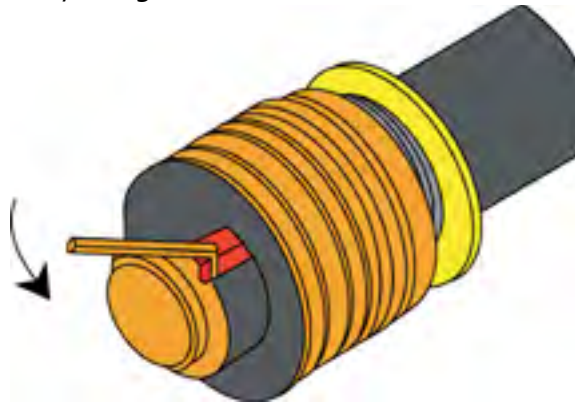

9. Fabricate or purchase a piston nut removal wrench.

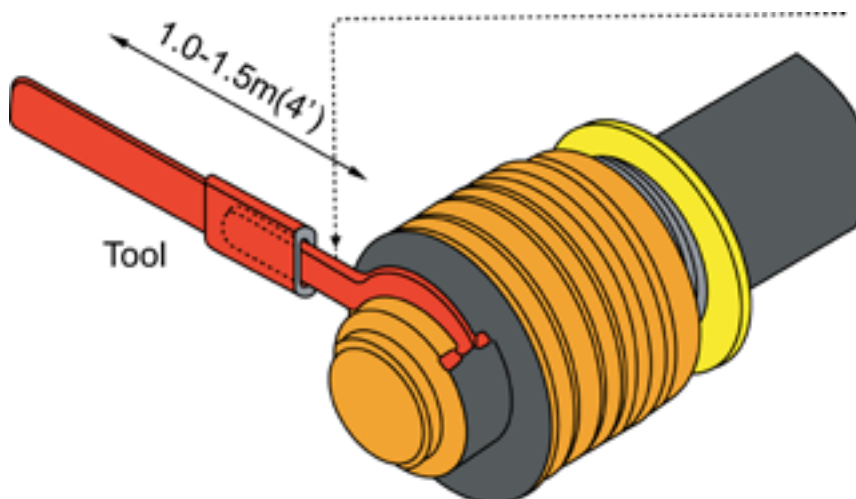

10. Use a plastic hammer to evenly pull off rod cover from end of piston rod. Be careful not to damage rod bushing and dust wiper, U-packing and other seals.

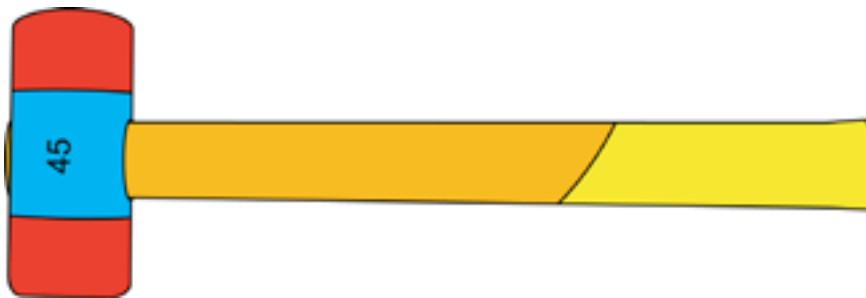
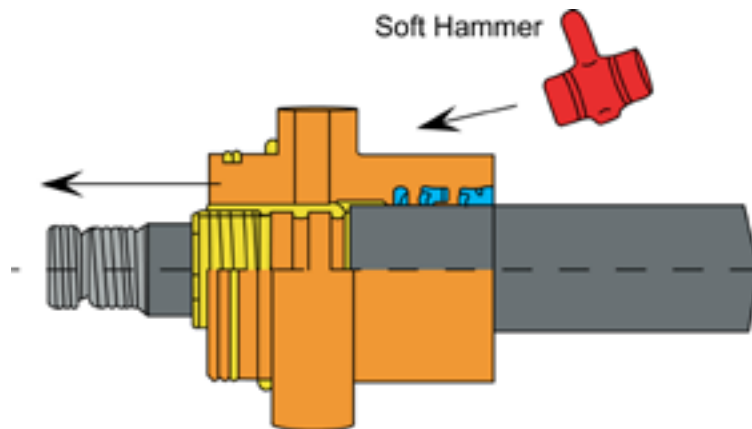

11. Use a dull, rounded-tip tool to pry off O-ring and backup ring.

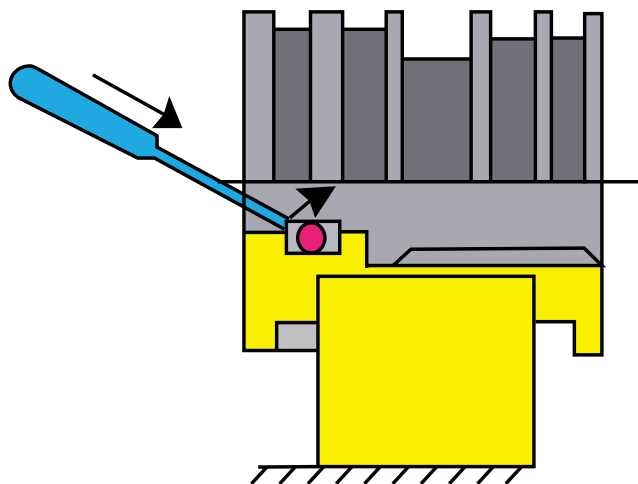

12. Find a screwdriver with an appropriate width tip to facilitate removal of slipper seal, wear ring and slide ring from the piston.

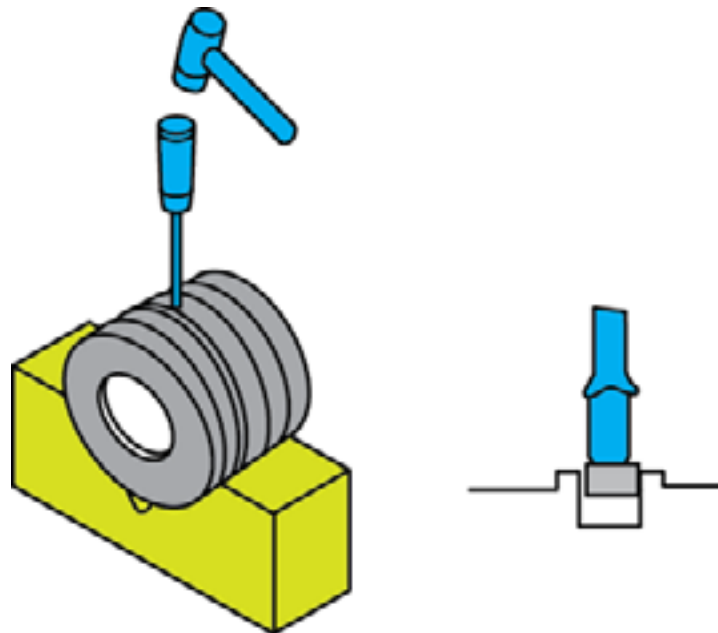

13. Pull off O-ring and backup ring from cylinder head.

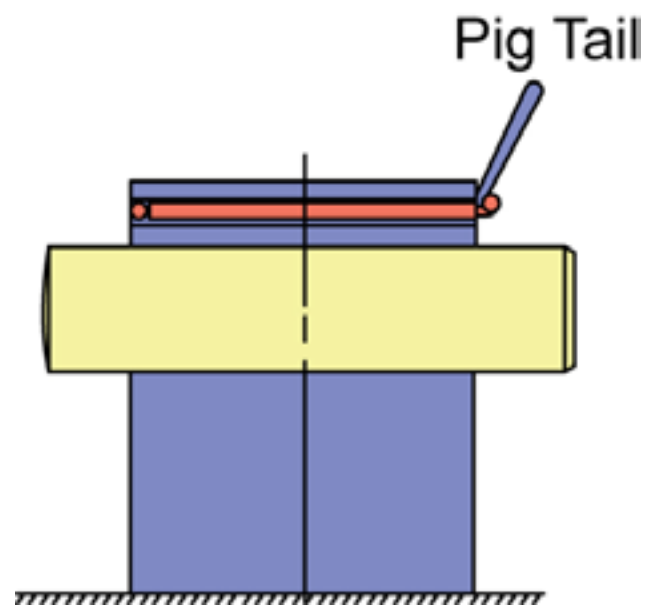

14. During disassembly of cylinder head, be careful not to damage the buffer seal and U-packing.

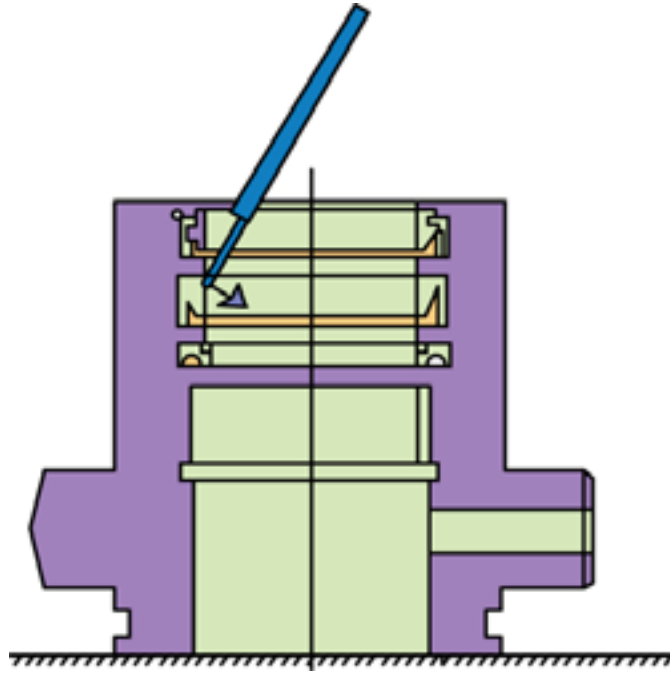

15. Disassemble the retaining ring and dust wiper. Separate the retaining ring and rod bushing.
16. Force out pin bushing from body of cylinder.

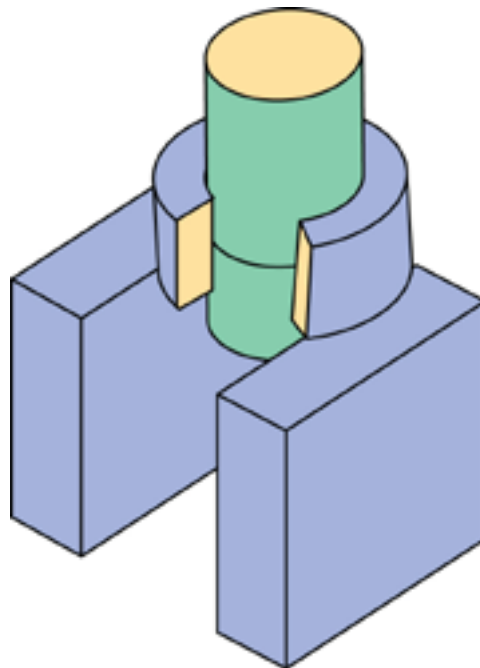

ASSEMBLY

NOTE: Assemble subassemblies of cylinder in the following order:

1. Cylinder body
2. Piston rod
3. Piston assembly
4. Cylinder head assembly

1. Assemble the pin bushing to piston rod and body of the cylinder.
2. Following the assembly of rod cover components, install the dust wiper and rod bushing to the rod cover. Insert the retaining rings.

IMPORTANT

Replace any part that shows evidence of damage or excessive wear. Replacement of all O-rings and flexible seals is strongly recommended. Before starting the cylinder assembly procedure, all parts should be thoroughly cleaned and dried, and/or pre-lubricated with clean hydraulic fluid. Prepare the work area beforehand to maintain cleanliness during the assembly procedure.

3. Pre-lubricate the O-rings and seals before assembly.

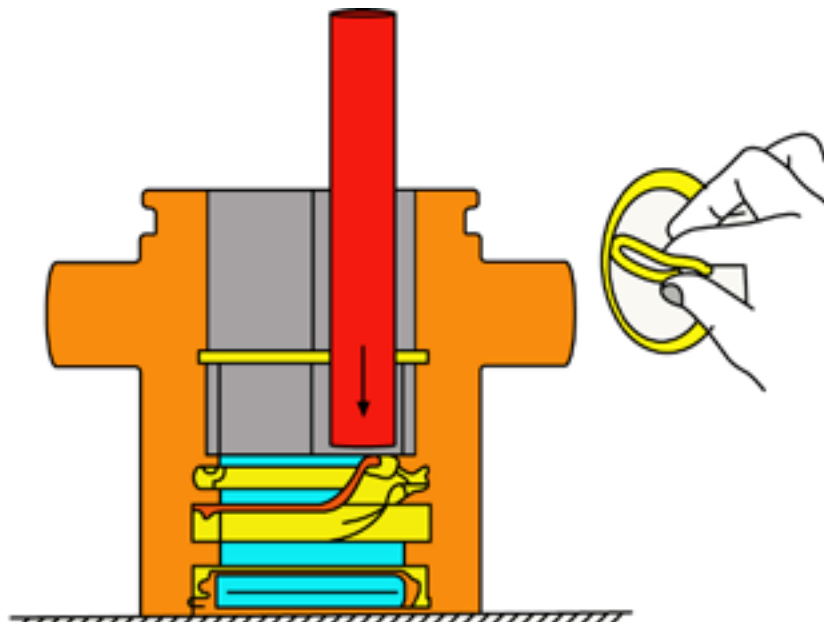

4. Before starting to rebuild piston assembly, heat slipper seal for 5 minutes in an oil bath warmed to 150°-180°C (302°-356°F). Use special slipper seal jig of specialized tools at the beginning of this procedure) to attach seal. Cool seal by pushing a retracting jig against seal for several minutes. Apply a strip of clean, see-through sealing tape around slipper seal to keep it free of dust.

5. Immobilize piston rod on solid support blocks. Assemble the O-ring and backup ring. Prepare to attach the rod cover assembly to piston rod. Push rod cover by tightening piston the nut.
6. Assemble the cushion ring and attach the piston assembly to the piston rod.
7. Use specially fabricate or factory sourced tool to tighten the piston nut.
8. Assemble the wear ring, slide ring and set screw to piston assembly.
9. Immobilize body of cylinder before assembly.
10. Apply fastener locking compound (Loctite), or an alternate manufacturer's equivalent product, to all end cover retaining bolts. Wrap a protective cushion around end of rod while tightening fasteners, to prevent possible damage to polished surface of rod, should a wrench slip during retightening.

General disassembly and assembly instructions, hydraulic cylinders

Removing the seal

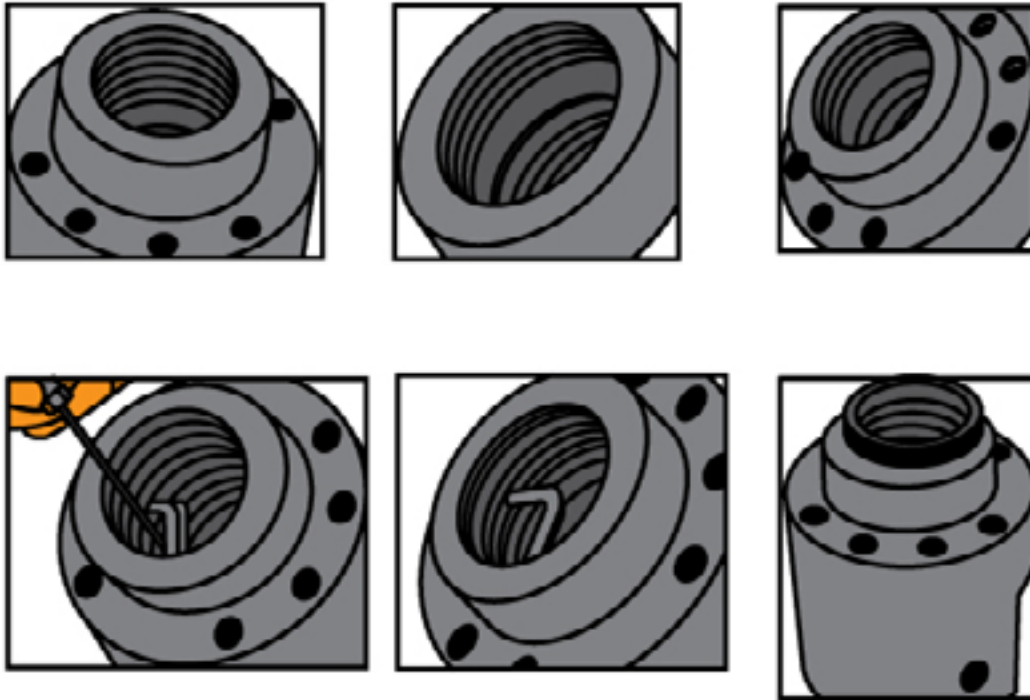

Insert a seal puller behind the rod seal.

Attention: be careful not to damage the base of the groove

Using the seal puller, pull the rod seal out of the groove

The rod seal can now be removed with using the finger.

Follow this procedure for all other seals during disassembly.

Fitting the piston seals

Fig.7



Fig.8

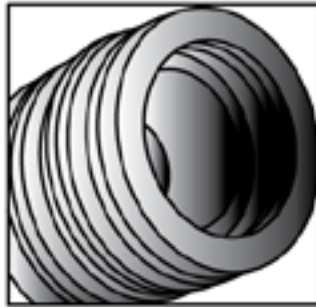

Fig.9



Fig.10

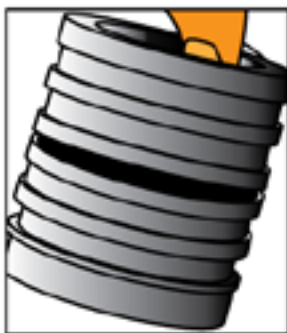

Fig.11



Fig.12



Fitting the piston seals

Fig.13



Please use an assembly bush and an assembly sleeve to install the PTFE seal. Place the PTFE seal over the assembly bush.

Fig.14

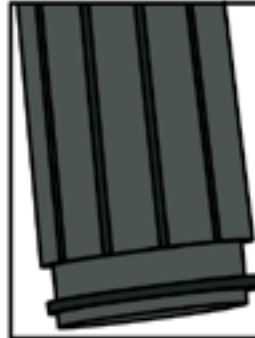

Then use the assembly sleeve to push the PTFE seal to the end of the assembly bush.

Fig.15

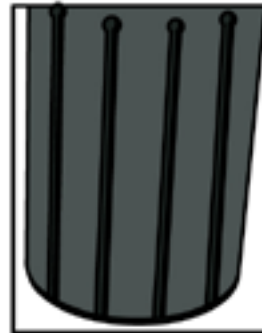

After pushing the PTFE seal to the end of the assembly bush, the assembly sleeve may be removed. We recommend that it not be removed, as it will be required again later.

Fig.16

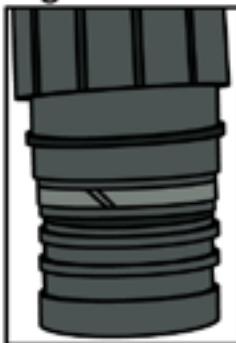

Place the assembly bush on the end of the piston. The assembly bush should be flush with the upper edge of the installed guide strip.

Fig.17

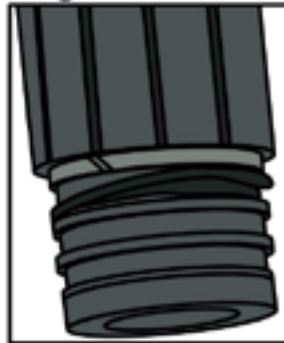

Using the assembly sleeve, push the PTFE seal into the groove on top of the O-ring.

Fig.18



Remove the assembly bush when the PTFE seal sits completely in the groove.

Fitting the piston seals

Fig. 19



Check whether the piston seal has been correctly installed and grease it.

Fig. 20



The piston seal deforms slightly during assembly with the assembly bush. A calibration sleeve is required to return the piston seal to its original shape. Push this over the piston

Fig. 21

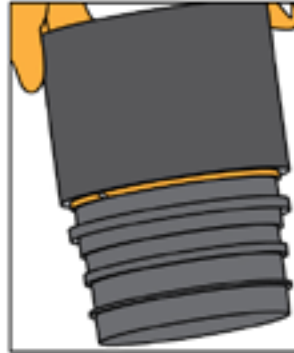

The calibration sleeve should remain on the piston for approx. 10 seconds to obtain the best results

Fig. 22



Fit the remaining guide strips as described in Fig 4 and 5 and repeat the calibration shown in Fig 20, make sure, however, that the calibration sleeve encloses all the seals.

Fitting the guide seals

Fig.23



Insert the seal in its groove using a flat-blade screwdriver with rounded blade edges.

Fig.24



Check that the seal has been fitted correctly.

Fig.25



Deform the guide strip to suit the corresponding diameter of the guide and insert it into the correct groove.

Fig.26

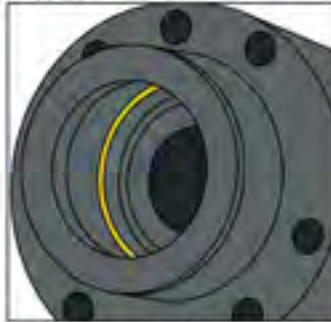

Perform the step shown in Fig.25 for all guide strips.

Fig.27



Check that the guide strips have been correctly installed.

Fig.28



Check the groove for the PTFE seals for damage and contamination.

Fig.29



Insert the O-ring into its groove.

Fig.30

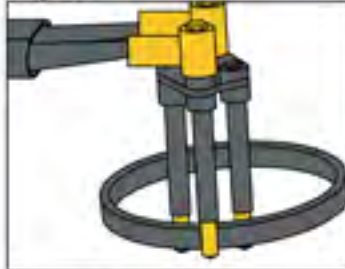

The PTFE seal can either be installed using a special tool or, alternatively, between two fingers.

Fig.31



To ease fitting in the groove, deform the PTFE seal into a kidney shape.

Fitting the guide seals

Fig.32

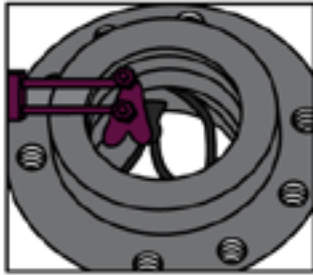

Make sure the non-deformed side is inserted into the groove first.

Fig.33

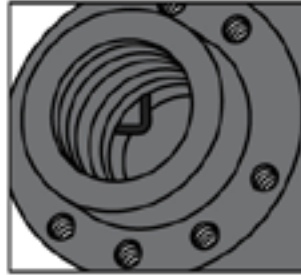

Then press the rest of the seal into the groove.

Fig.34

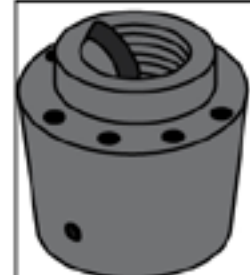

Insert the rod seal

Fig. 35

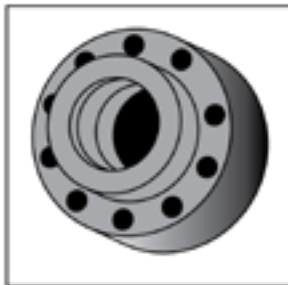

Check that all theseal have been correctly fitted and grease them

Fig. 36

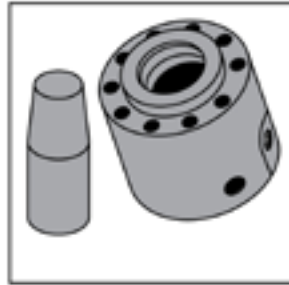

Use an assembly drift with a diameter corresponding to inner diameter of the guide.

Fig. 37

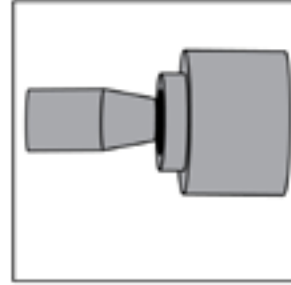

Insert this into guide in order to restore the PTFE seals to its original shape.

Fig.38

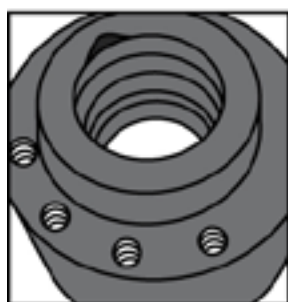

Place the O-ring in the corresponding groove.

Fig.39

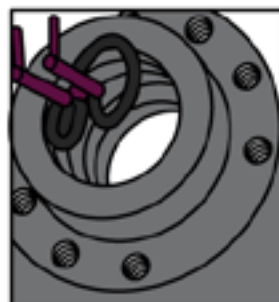

Deform the wiper into a kidney shape as already described in Fig.30 and 31

Fig.40

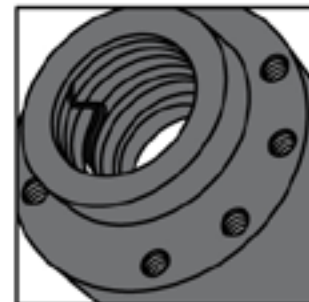

Place the wiper in the groov as described in Fig. 32 and

Fitting the guide seals

Fig. 41

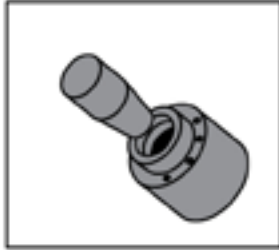

Reinser the assembly drift into the guide.

Fig. 42

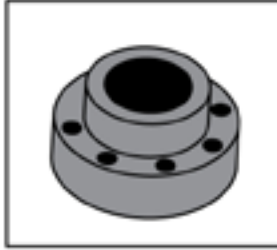

Ensure that all seal have been fitted corectly.

Piston Seals

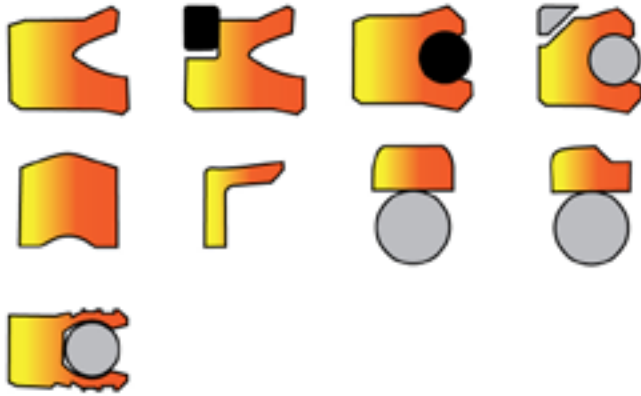

Practical exercise, hydraulic cylinder overhaul
Report your findings in the space below.

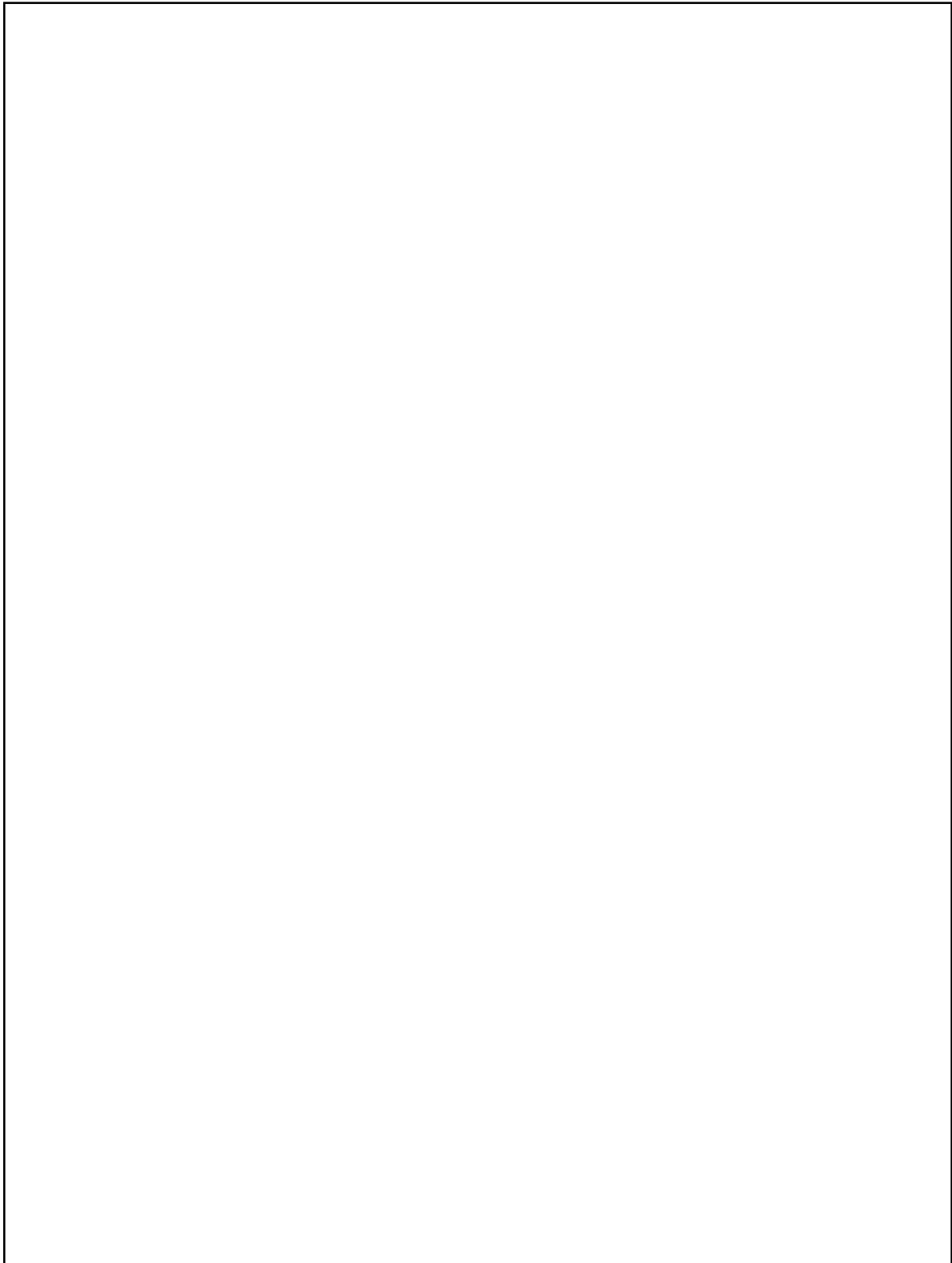
A large, empty rectangular box with a thin black border, intended for the student to write their report on the hydraulic cylinder overhaul. The box occupies most of the page's vertical space.

This curriculum has been developed as part of the Learning and Knowledge Development (LKD) Facility, initiated by the Swedish International Development Agency (Sida) and the United Nations Industrial Development Organization (UNIDO). The LKD Facility is a platform to promote industrial skills development among young people in emerging economies. Working with the private sector through Public Private Development Partnerships, the LKD Facility supports the establishment and upgrading of local industrial training academies to help meet the labour market's increasing demand for skilled employees, ultimately contributing to inclusive and sustainable industrial development.



UNITED NATIONS
INDUSTRIAL DEVELOPMENT ORGANIZATION

UNIDO Headquarters
Vienna International Centre
P.O. Box 300. A-1400 Vienna Austria
Tel: +43 (1) 26026-3752
Email: lkd-facility@unido.org

www.lkdfacility.org