

MECHANISM TUTORIAL

Within this tutorial, you will explore the assembly and animation capabilities of assembly mode's mechanism option. The nutcracker model shown in Figure 12-92 will be utilized. You will model each component in part mode then assemble each using mechanism joints.

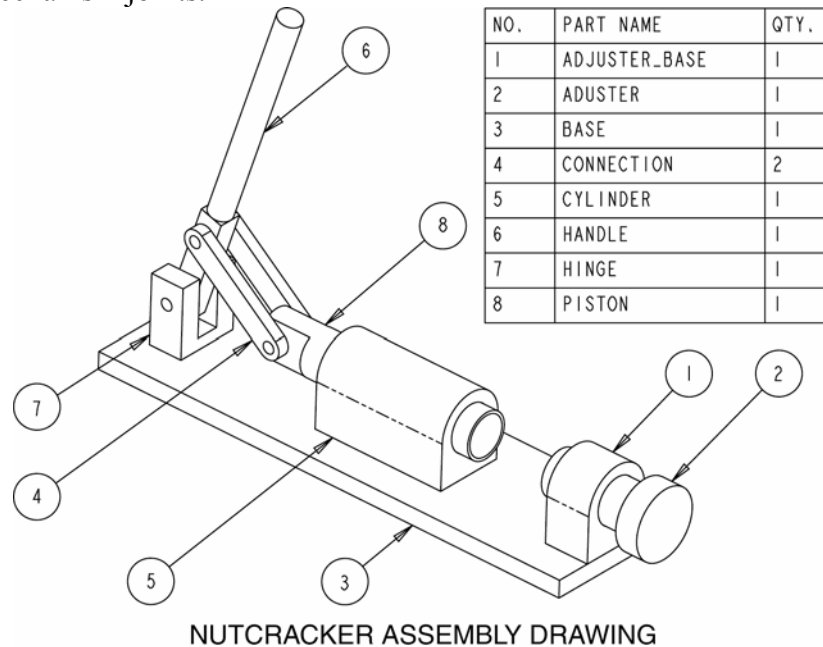

Figure 12-92: Mechanism Assembly

Assembly mode provides powerful tools for modeling a complete design. Traditional bottom-up constraints necessitate fully constrained components. When a component is not fully constrained, it is considered packaged and presents assembly difficulties. The mechanism option provides tools for assembling components in a manner that replicates a real design. Joints such as pin, cylinder, slider, and ball are available. Notice in Figure 12-92 the connection linkage that exists from the handle through the connection part through to the piston part. The mechanism joints defining these parts only constrain each component within the degrees of freedom required by the design. Within this assembly, the handle can be moved which in turn will move the piston. This will be demonstrated. The following topics will be covered in this tutorial:

- Modeling assembly parts.
- Assembling a Mechanism.
- Manipulating a mechanism.
- Running a Mechanism's Motion.
- Animating a mechanism.

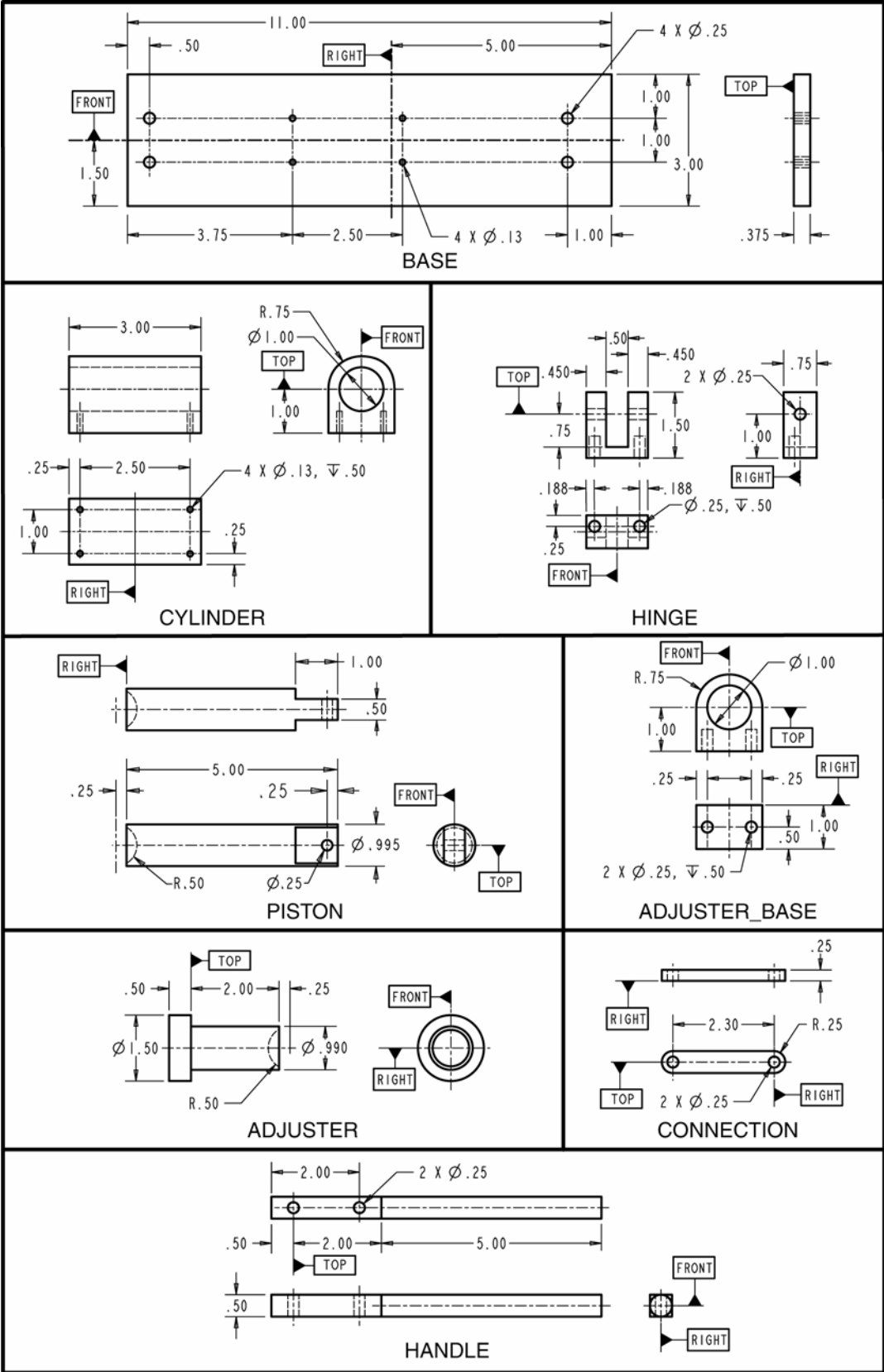

Figure 12-93: Assembly Parts

Modeling Assembly Parts

The assembly in this tutorial consists of eight different parts: base, cylinder, hinge, piston, adjuster_base, adjuster, connection, and handle. There will be two instances of the connection part. Use part mode to model each of the parts as shown in Figure 12-93. When modeling each part, pay careful attention to the locations of your datum planes. For proper assembly of the mechanism, your datum planes should match the datum planes represented in each part's drawing.

Assembling a Mechanism

Within this segment of the tutorial you will assemble the parts comprising the design. Within this exercise, you will not use a template file. Do not start this segment of the tutorial until you have modeled all the parts portrayed in Figure 12-93.

Step 1: Start Pro/ENGINEER and then select **FILE >> NEW**.

Step 2: On the New dialog box, deselect the **USE DEFAULT TEMPLATE OPTION**.

Within this tutorial, do not use Pro/ENGINEER's default template.

Step 3: Create a new Assembly object file named *NUTCRACKER.ASM*.

Step 4: On the New File Options dialog box, select the **EMPTY** template file then select **OK**.

Step 5: Select **COMPONENT >> ASSEMBLE** on the Assembly menu.

Step 6: Using the Open dialog box, place the *BASE* part.

Without any existing features or components, Pro/ENGINEER will place the first component without requiring any constraints or joints. If you inadvertently created Pro/ENGINEER's default datum planes, you can mate and/or align the *BASE* part to these datum planes

Step 7: Select **COMPONENT >> ASSEMBLE** and open the *CYLINDER* part.

Step 8: Using traditional assembly constraints, assemble the Cylinder part as shown in Figure 4-mech.

There are two ways to add components to a mechanism: Fixed and By Connection. The Fixed option is identical to the traditional way of assembling components in Pro/ENGINEER. The By Connection option assembles components through joint definitions. It allows components to

move based on the degrees of freedom provided by the selected joint. For the cylinder part, assemble the component with one Mate constraint and two Align constraints as shown in the illustration.

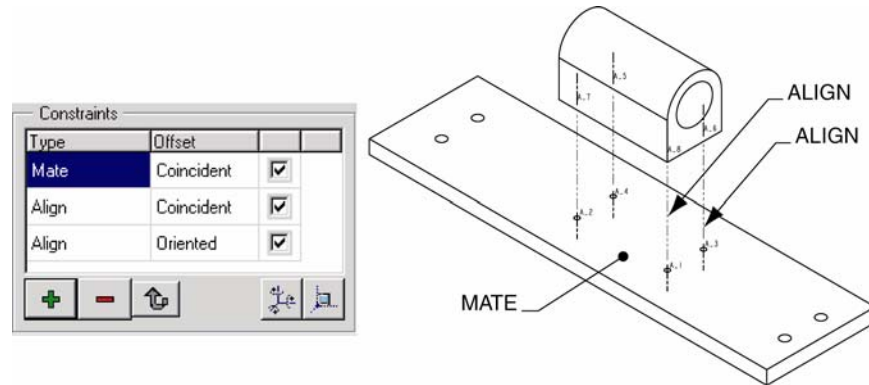

Figure 12-94: Cylinder Fixed Constraints

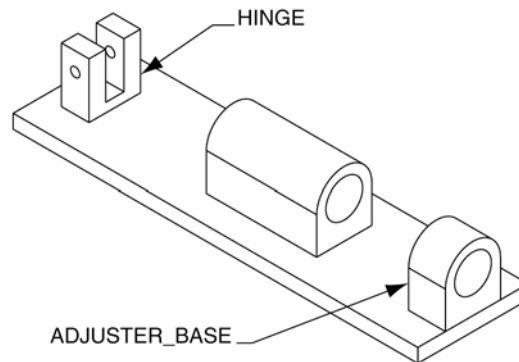

Figure 12-95: *Adjuster_Base* and Hinge Fixed Constraints

Step 9: When the Cylinder part is fully constrained, select **OK** to exit the dialog box.

Step 10: Use the same technique for assembling the cylinder part to constrain the *HINGE* and *ADJUSTER_BASE* parts (Figure 12-95).

As with the cylinder part, use two align constraints and one mate constraint for each part. Your assembly should appear as shown in the illustration.

Next you will assemble the Piston part using a Cylinder joint. Other available joints include: Pin, Bearing, Slider, Planar, and Ball.

Step 11: Select **ASSEMBLE** then open the *PISTON* part.

Step 12: On the Component Placement dialog box select CONNECTIONS option.

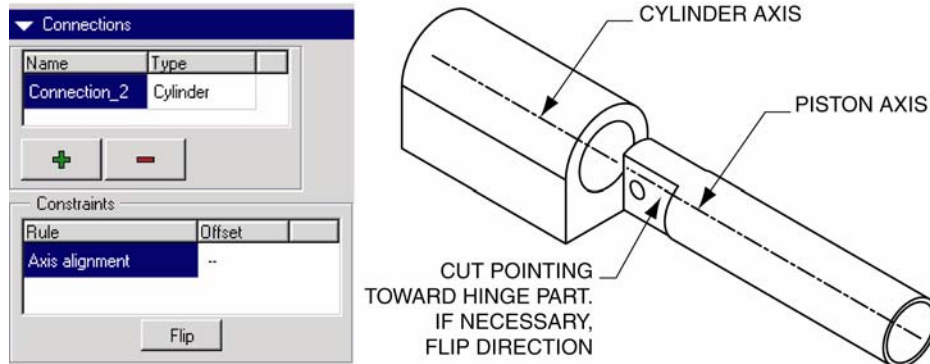

Figure 12-96: Cylinder Joint Definition

Step 13: On the Component Placement dialog box, select CYLINDER as the connection type (see Figure 12-96).

Step 14: Select the two axes shown in Figure 12-96.

A Cylinder joint type is defined through the alignment of two axes. This joint type provides two degrees of freedom: one linear and one rotational.

Step 15: If necessary, select the FLIP option to point the piston's cut feature toward the hinge part (see Figure 12-96).

Step 16: On the dialog box, select the MOVE tab.

You will reposition the piston part to match Figure 8mech.

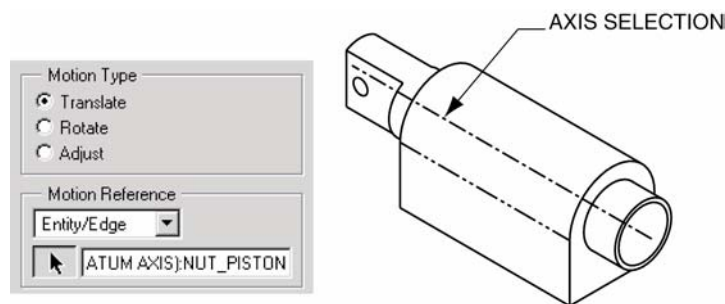

Figure 12-97: Move Option

Step 17: With the Translate and Entity/Edge options selected, pick the axis of the piston part (see Figure 12-97).

Step 18: Move the Piston part's location to approximately match Figure 12-97 then select the Place tab.

After selecting the Place tab on the component placement dialog box, notice the current placement status of the part. The placement status should state “Connection Definition Complete”.

NOTE: You can also use the Mechanism >> Drag option to move components that have mechanism joints.

Step 19: Select **OK** on the dialog box.

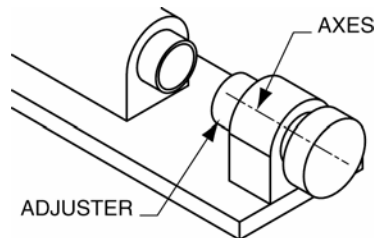

Figure 12-98: Adjuster Placement

Step 20: Use the **ASSEMBLE** option to open the *ADJUSTER* part.

Step 21: Use the same technique for assembling the piston part to constrain the *ADJUSTER* part (Figure 12-98).

Use Cylinder as the connection for the component. If necessary, use the Flip option and the Move tab to position the component to match the illustration.

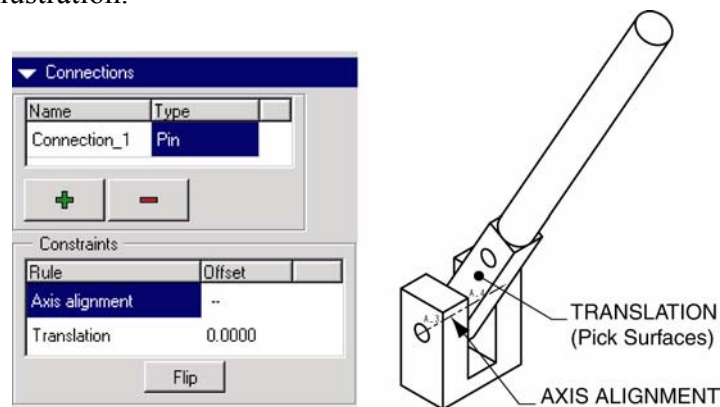

Figure 12-99: Handle Placement

Step 22: Use the **ASSEMBLE** option to open the *HANDLE* part.

Step 23: Select the **PIN** joint type under the **Connections** option (see Figure 12-99).

Pin connections provide one rotational degree of freedom. It is defined through the alignment of two axes and the aligning or mating of two planes.

Step 24: Align the hole axes of the handle and hinge parts as shown in Figure 12-99.

Step 25: With the Translation constraint type selected, mate one side of the handle part with the end side surface of the hinge part.

Step 26: Use the Move tab to rotate the handle to the approximate location shown in Figure 12-99.

Under the Move tab, use Rotate as the Motion Type and Entity/Edge as the Motion Reference. The handle should be pointing toward the center of the base part.

Step 27: Select OK to exit the dialog box.

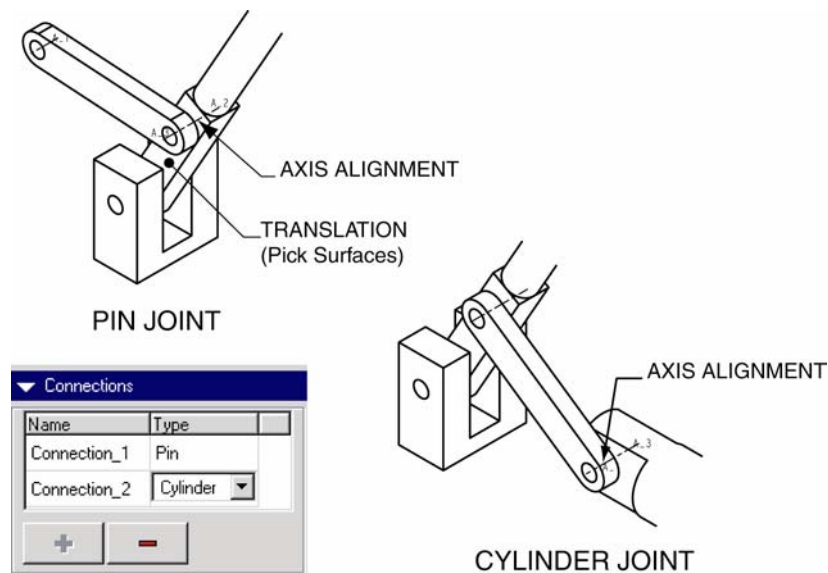

Figure 12-100: Connection Part Placement

Step 28: Assemble the *CONNECTION* part.

Step 29: Create the PIN joint shown in Figure 11mech.

The connection part will have two joints: one pin and one cylinder. The pin joint will join the connection part to the handle part. The cylinder joint will join the connection part to the piston. If necessary, use the Flip option to create the mate translation connection.

Step 30: Use the Move tab on the dialog box to rotate the connection part to the approximate location shown in Figure 12-100.

Step 31: Create the **CYLINDER** joint shown in **Figure 11mech**.

The Plus icon located under the connection names on the dialog is used to add new joint types. After creating the cylinder joint, your assembly connection will not look like the illustration. This is typical of a Pro/ENGINEER looped mechanism. In a later step, you will execute the Connect option to assume a successful assembly.

Step 32: If the placement status signifies a complete connection, select **OK** to exit the dialog box.

Step 33: Use the same technique for assembling the first connection part to place the second instance of the connection part.

Repeat Steps 28 through 32 to place the second instance of the connection part.

Step 34: Select **DONE/RETURN** to exit the Component menu.

Step 35: Select **MECHANISM >> CONNECT >> RUN** to connect the loop assembly.

Instructional Point

If you do not get a successful assembly after selecting the Run option, use the Mechanism >> Settings option to adjust the tolerance of the assembly (see Figure 12-101).

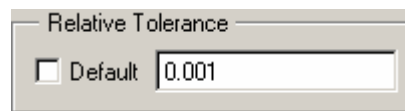

Figure 12-101: Assembly Setting

Step 36: If you get a positive confirmation message, select **YES** to accept the successful assembly.

Step 37: Save the assembly.

Manipulating a Mechanism

This segment of the tutorial will demonstrate how components can be dragged through any defined degrees of freedom. In addition, you will create snapshots of component placements that will be used in the last segment of this tutorial to animate the mechanism.

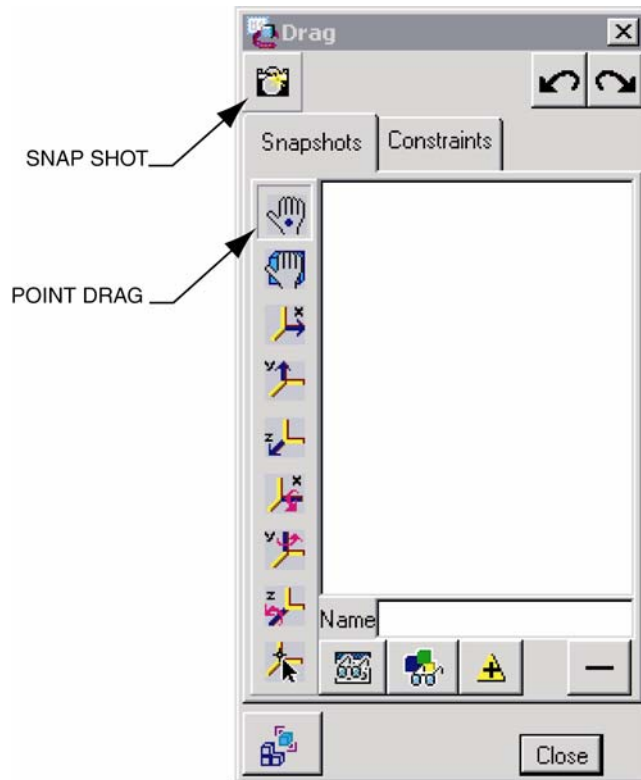

Figure 12-102: Drag Entity Selection

- Step 1:** Select the **DRAG** option from under the **Mechanism** menu.
- Step 2:** On the **Drag** dialog box, select the **Point Drag** icon (Figure 12-102) then select the end of the handle part (see Figure 12-103).

The **Drag** dialog box is used to drag components on the screen. Use the **Point** option to select the end of the handle part. After selecting the handle, you can dynamically drag the component with the mouse. Use the **Left-Mouse** button to end dragging.

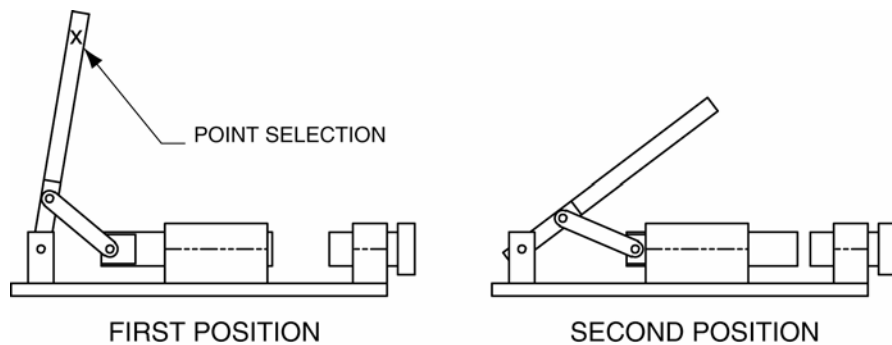

Figure 12-103: Drag Positions

- Step 3:** Drag the handle to the **First Position** shown in Figure 12-103.

Figure 12-103 represents a side view of the assembly. You can utilize any orientation to include a user-defined viewpoint.

Step 4: On the Drag dialog box, select the SNAPSHOT icon (Figure 12-102).

Snapshots can be used to restore a mechanism's position and to create animations. You will use the snapshots created in this segment to animate the mechanism in the last segment of this tutorial.

Step 5: Drag the handle to the second position shown in Figure 12-103 then create a second snapshot.

Step 6: Close the Drag dialog box.

Running a Mechanism's Motion

Motion, as defined by the degrees of freedom within a mechanism, can be animated. Within this segment of the tutorial, you will define the motion of the assembly through the use of a driver.

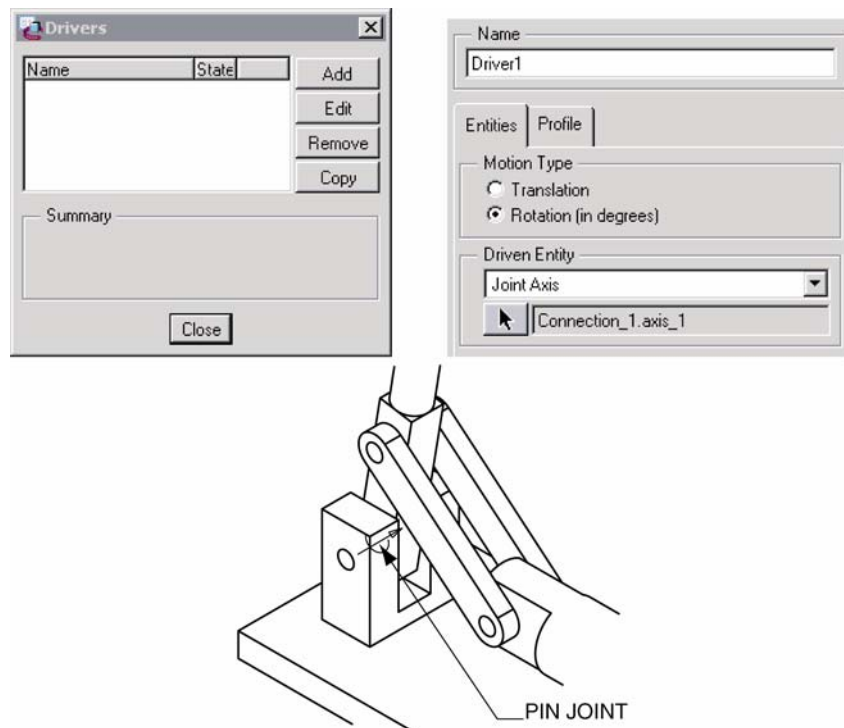



Figure 12-104: Driver Creation

Step 1: Select the MODEL >> DRIVERS option on the Mechanism menu.

Step 2: On the Drivers dialog box, select the ADD option (Figure 12-104).

- Step 3:**  For the Driven Entity, select the pick icon, then on the work screen pick the pin joint shown in Figure 12-104.
- Step 4:** If available, on the Driver Editor dialog box, select ROTATION as the Motion Type (Figure 12-104).
- Step 5:** Select the Profile tab then select VELOCITY as the specification (Figure 12-105).
- Step 6:** Change the Magnitude option to COSINE then enter the values shown in Figure 12-105.
- Step 7:** Select the GRAPH option to observe the graph of your mechanism.
- Step 8:** Close the Graph windows.

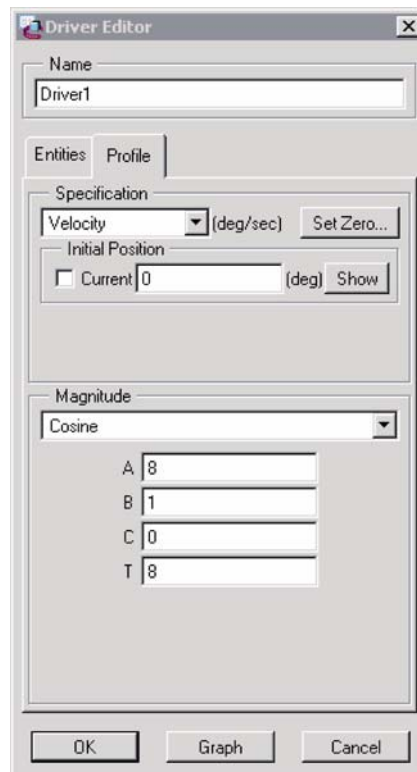

Figure 12-105: Driver Editor Dialog Box

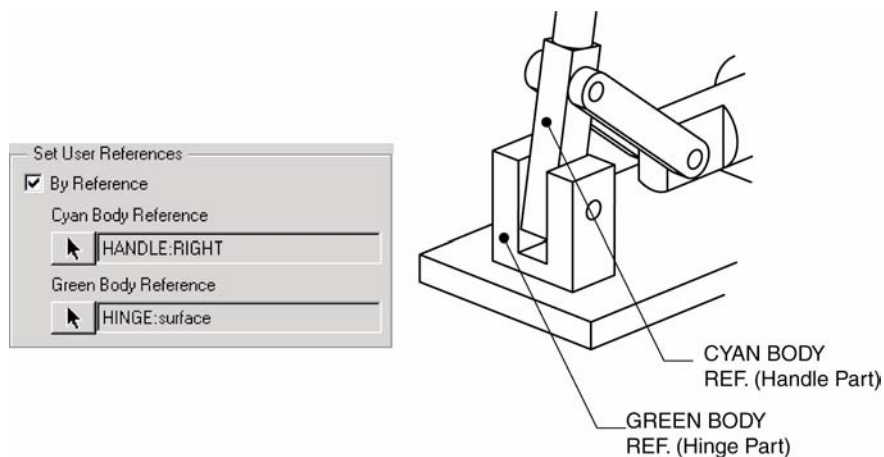

Figure 12-106: Zero Reference Selection

Step 9: Select the **SET ZERO** option on the dialog box then set the **CYAN BODY REFERENCE** and the **GREEN BODY REFERENCE** as shown in **Figure 12-106**.

This will define the starting point for the mechanism animation.

Step 10: Select **OK** to exit the **Joint Axis Settings** dialog box.

Step 11: On the **Driver Editor** dialog box, enter **10.00** as the **Initial Angle** for the driver (**Figure 12-107**).

This setting will establish an initial position for the mechanism 10 degrees from the set zero position.

Instructional Point

Notice on the work screen the arrow representing the joint's joint. Using the right-hand rule with your thumb pointing in the direction of the arrow, your fingers will point in the direction of driver rotation. If necessary, you might have to enter a negative 10.00 value for the initial angle.



Figure 12-107: Initial Angle Setting

Step 12: Select **OK** to exit the **Driver Editor** dialog box.

Step 13: Close the **Drivers** dialog box.

Step 14: Select the **RUN MOTION** option under the **Mechanism** menu.

After selecting the Run Motion option, Pro/ENGINEER will launch the Motion Definitions dialog box. This dialog box is used to establish multiple motion definitions for a mechanism.

Step 15: Select the **ADD** option on the Motion Definition dialog box.

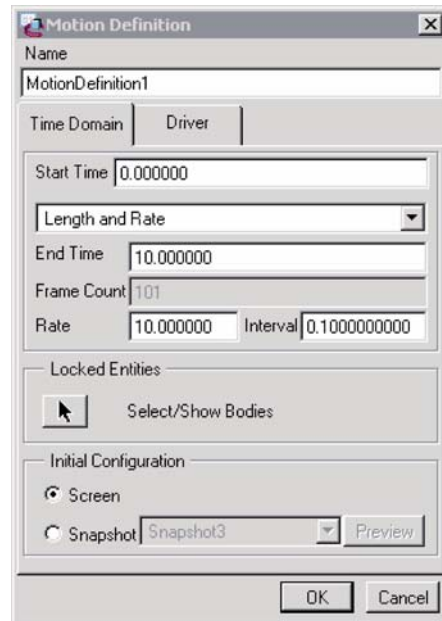

Figure 12-108: Motion Definition Dialog Box

Step 16: Select **OK** to accept the default settings on the Motion Definition dialog box (Figure 12-108).

Step 17: Select **RUN** on the Motion Definitions dialog box.

With any luck, after selecting the Run option, your mechanism should animate based on defined degrees of freedom and the set driver. If you have unexpected results in your animate, try adjusting the driver's profile values or the driver's initial angle value.

Step 18: Close the Motion Definitions dialog box.

Step 19: Select **RESULTS >> PLAYBACK** on the Mechanism menu

Step 20: Select the **PLAY** option on the Results Playback dialog box.

Step 21: Use options on the Animate dialog box to run the results of your motion study (Figure 12-109).

Step 22: Close out of the Mechanism option and save your assembly.

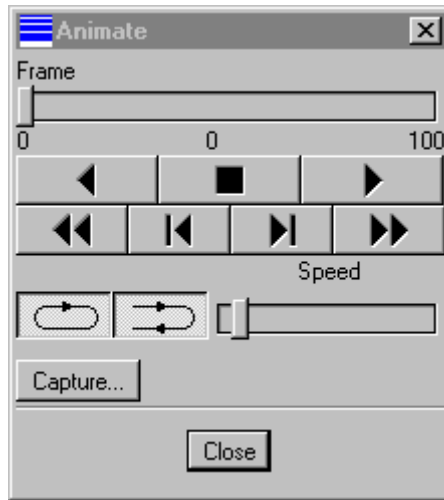

Figure 12-109: Animate Dialog Box

Animating a Mechanism

Mechanisms can be animated using Pro/ENGINEER's Animation mode. Within this segment of the tutorial, you will use the snapshots created previously to animate the nutcracker assembly.

Step 1: Using Pro/ENGINEER's Menu Bar, select **APPLICATIONS >> ANIMATION**.

Upon selecting the Animation option, Pro/ENGINEER will reveal the Animation toolbar (Figure 12-110) and, at the bottom of the screen, a timeline.

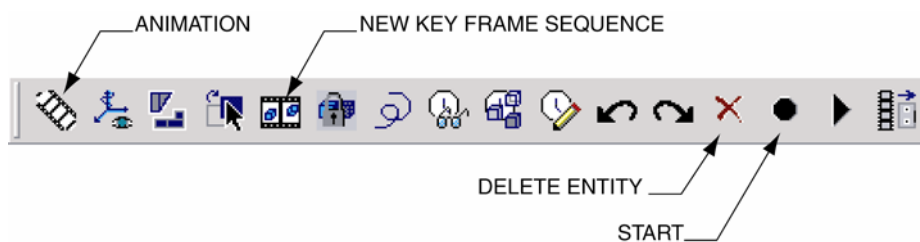



Figure 12-110: Animation Dialog box

Step 2:  Select the **ANIMATION** icon on the toolbar then select the **NEW** icon to create a new animation.

Step 3: Close the Animation dialog box.

Step 4: Double pick the timeline at the bottom of the work screen and set the time domain values shown in Figure 12-111.

Step 5: Select OK to create the time domain.

Step 6:  Select the **NEW KEY FRAME SEQUENCE** icon.

Multiple key frame sequences can be created for an animation. Within this tutorial, two will be used. The first sequence will utilize the two snapshots created previously to animate the handle and piston linkage. The second sequence will animate the adjuster.

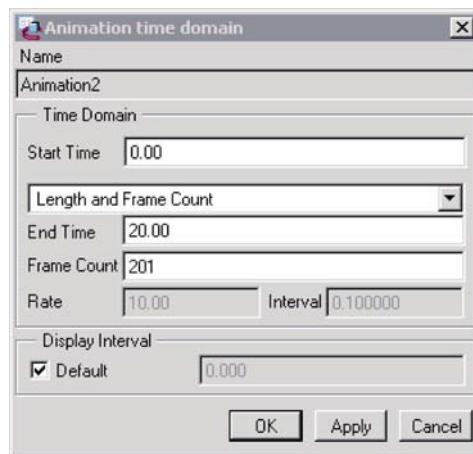



Figure 12-111: Time Domain

Step 7:  On the dialog box, use the **ADD KEY FRAME** icon to create the three key frames shown on the **Key Frame Sequence** dialog box (Figure 12-112).

Two snapshots should currently exist. Use the Add Key Frame icon to create the three key frames shown in Figure 25 (snapshot1 at 0 sec, snapshot2 at 10 sec, and snapshot1 at 20 second). To perform this, select an existing snapshot, set a specific time value, and then select the Add Key Frame icon.

Step 8: Select OK when your **Key Frame Sequence** dialog box matches Figure 12-112.

Step 9:  Select the **START** icon on the **Animation** toolbar (Figure 12-111).

Your handle and piston linkage should animate.

Step 10:



Select the **NEW KEY FRAME SEQUENCE** icon.

The next key frame sequence will animate the adjuster part.

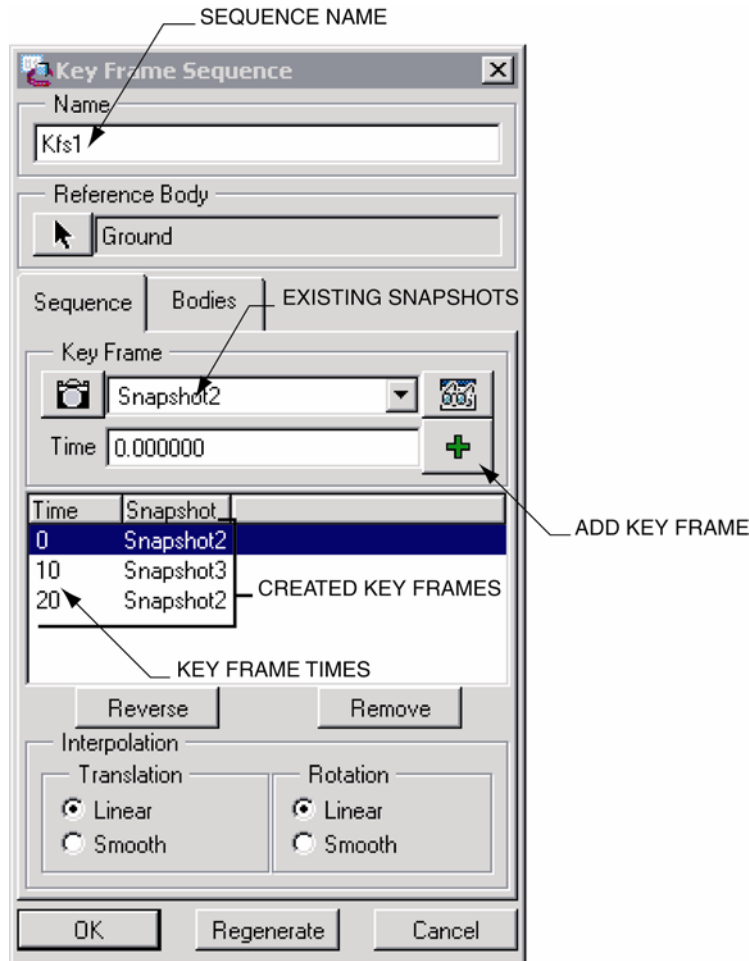

Figure 12-112: Key Frame Sequence Dialog Box

Step 11:



Select the **NEW SNAPSHOT** icon on the **Key Frame Sequence** dialog box.

The New Snapshot icon will launch the Drag dialog box (Figure 12-113). This dialog box is also accessible directly from the Animation dialog box.

Step 12:

Select the **POINT DRAG** icon then drag the adjuster part to the **SNAPSHOT4** position shown in Figure 12-113.

Your snapshot numbers may be different from those represented in this tutorial. You can approximate the exact location for each shot.

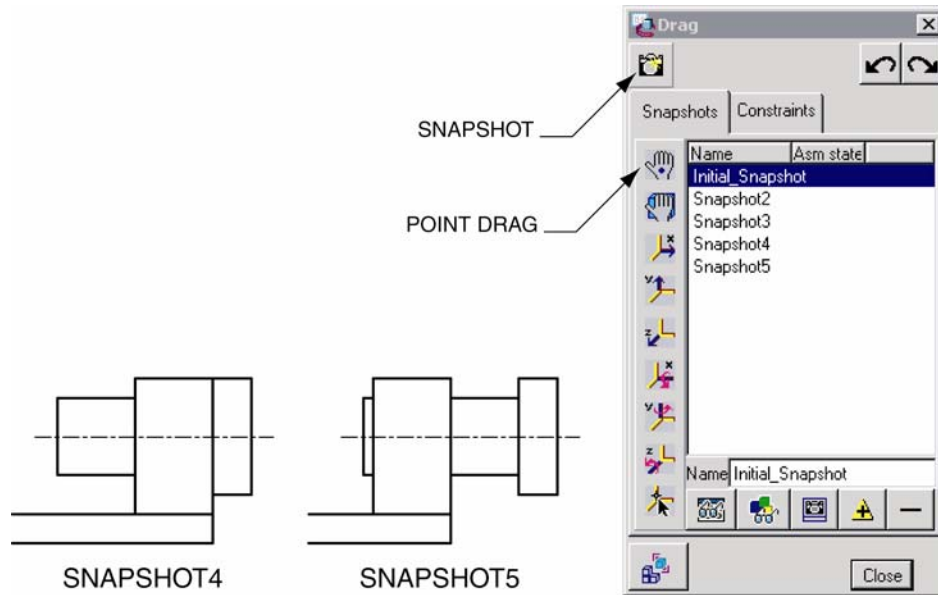



Figure 12-113: Snapshot Creation

- Step 13:**  Select the **SNAPSHOT** icon to create snapshot4.
- Step 14:** Select the **POINT DRAG** icon then drag the adjuster part to the **SNAPSHOT5** position shown in Figure 12-113.
- Step 15:**  Select the **SNAPSHOT** icon to create snapshot5 then close the **Drag** dialog box.
- Step 16:** **Modify Snapshot5** (see Figure 12-114) to have a value of 10 seconds.
- Step 17:** Select **OK** to close the **Key Frame Sequence** dialog box.

Key Frame Sequences can be modified with the Animation >> Key Frame Sequence option on Pro/ENGINEER's menu bar. Your timeline should look similar to Figure 12-115. Key frames on the timeline are represented by the triangle symbol. They can be manipulated on the timeline by dragging with the mouse.

- Step 18:** Use your mouse to drag the second key frame sequence to the position shown in Figure 12-115.

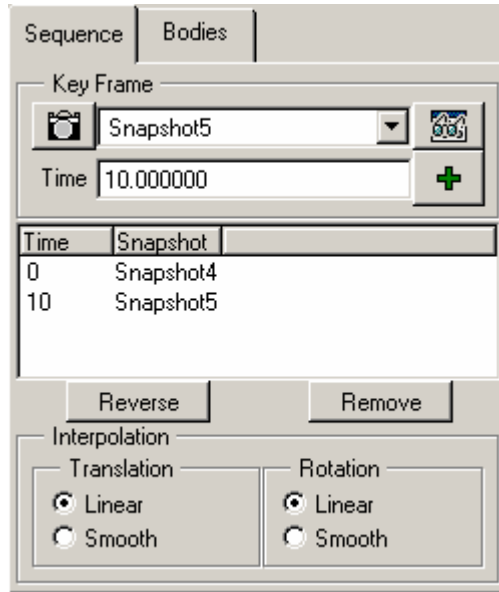

Figure 12-114: Key Frame Sequence Dialog box

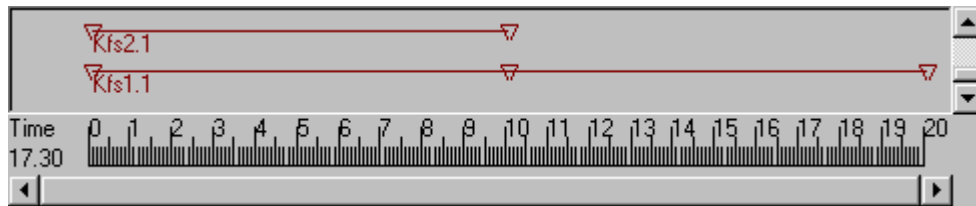



Figure 12-115: Animation Timeline

- Step 19:**  **Run the animation by selecting the START icon on the Animation toolbar.**
- Step 20:**  **Playback the created animation by selecting the Playback icon.**
- Step 21:** **Save your assembly file.**