



## Media Resources

---

Revised: February 7, 2017

A media resource is a software-based or hardware-based entity that performs media processing functions on the data streams to which it is connected. Media processing functions include mixing multiple streams to create one output stream (conferencing), passing the stream from one connection to another (media termination point), converting the data stream from one compression type to another (transcoding), streaming music to callers on hold (music on hold), echo cancellation, signaling, voice termination from a TDM circuit (coding/decoding), packetization of a stream, streaming audio (annunciation), and so forth. The software-based resources are provided by the Cisco Unified Communications Manager (Unified CM) IP Voice Media Streaming Service (IP VMS). Digital signal processor (DSP) cards provide both software and hardware based resources.

This chapter explains the overall Cisco Unified CM media resources architecture and Cisco IP Voice Media Streaming Application service, and it focuses on the following media resources:

- [Voice Termination, page 7-4](#)
- [Transcoding, page 7-6](#)
- [Media Termination Point \(MTP\), page 7-7](#)
- [Trusted Relay Point, page 7-16](#)
- [Annunciator, page 7-16](#)
- [Cisco RSVP Agent, page 7-18](#)
- [Music on Hold, page 7-18](#)

Use this chapter to gain an understanding of the function and capabilities of each media resource type available on Unified CM and to determine which resource are required for your deployment. For information on conferencing resources, refer to the chapter on [Cisco Rich Media Conferencing, page 11-1](#).

For proper DSP sizing of Cisco Integrated Service Router (ISR) gateways, you can use the Cisco Unified Communications Sizing Tool (Unified CST), available to Cisco employees and partners at <http://cucst.cloudapps.cisco.com/landing>. If you are not a Cisco partner or employee, you can use the DSP Calculator at <http://www.cisco.com/go/dspcalculator>.

## What's New in This Chapter

[Table 7-1](#) lists the topics that are new in this chapter or that have changed significantly from previous releases of this document.

**Table 7-1** *New or Changed Information Since the Previous Release of This Document*

New or Revised Topic	Described in:	Revision Date
Unsolicited Notify DTMF method	<a href="#">SIP Trunk MTP Requirements, page 7-11</a>	February 7, 2017
Multicast music on hold (MoH) source	<a href="#">Rebroadcast External Multicast Source, page 7-23</a>	June 14, 2016
Digital signal processor (DSP) resources and the PVDM4 module	<a href="#">Audio Transcoding Resources, page 7-7</a> <a href="#">MTP Resources, page 7-15</a> <a href="#">Capacity Planning for Media Resources, page 7-31</a>	June 15, 2015

## Media Resources Architecture

To properly design the media resource allocation strategy for an enterprise, it is critical to understand the Cisco Unified CM architecture for the various media resource components. The following sections highlight the important characteristics of media resource design with Unified CM.

### Media Resource Manager

The Media Resource Manager (MRM), a software component in the Unified CM, determines whether a media resource needs to be allocated and inserted in the media path. This media resource may be provided by the Unified CM IP Voice Media Streaming Application service or by digital signal processor (DSP) cards. When the MRM decides and identifies the type of the media resource, it searches through the available resources according to the configuration settings of the media resource group list (MRGL) and media resource groups (MRGs) associated with the devices in question. MRGLs and MRGs are constructs that hold related groups of media resources together for allocation purposes and are described in detail in the section on [Media Resource Groups and Lists, page 7-35](#).

[Figure 7-1](#) shows how a media resource such as a transcoder may be placed in the media path between an IP phone and a Cisco Unified Border Element when a common codec between the two is not available.

Figure 7-1 Use of a Transcoder Where a Common Codec Is Not Available

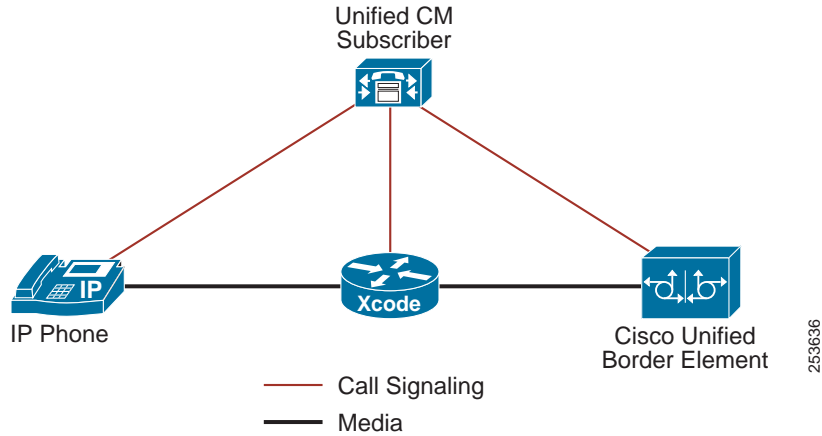

Unified CM communicates with media resources using Skinny Client Control Protocol (SCCP). This messaging is independent of the protocol that might be in use between Unified CM and the communicating entities. Figure 7-2 shows an example of the message flow, but it does not show all of the SCCP or SIP messages exchanged between the entities.

Figure 7-2 Message Flow Between Components

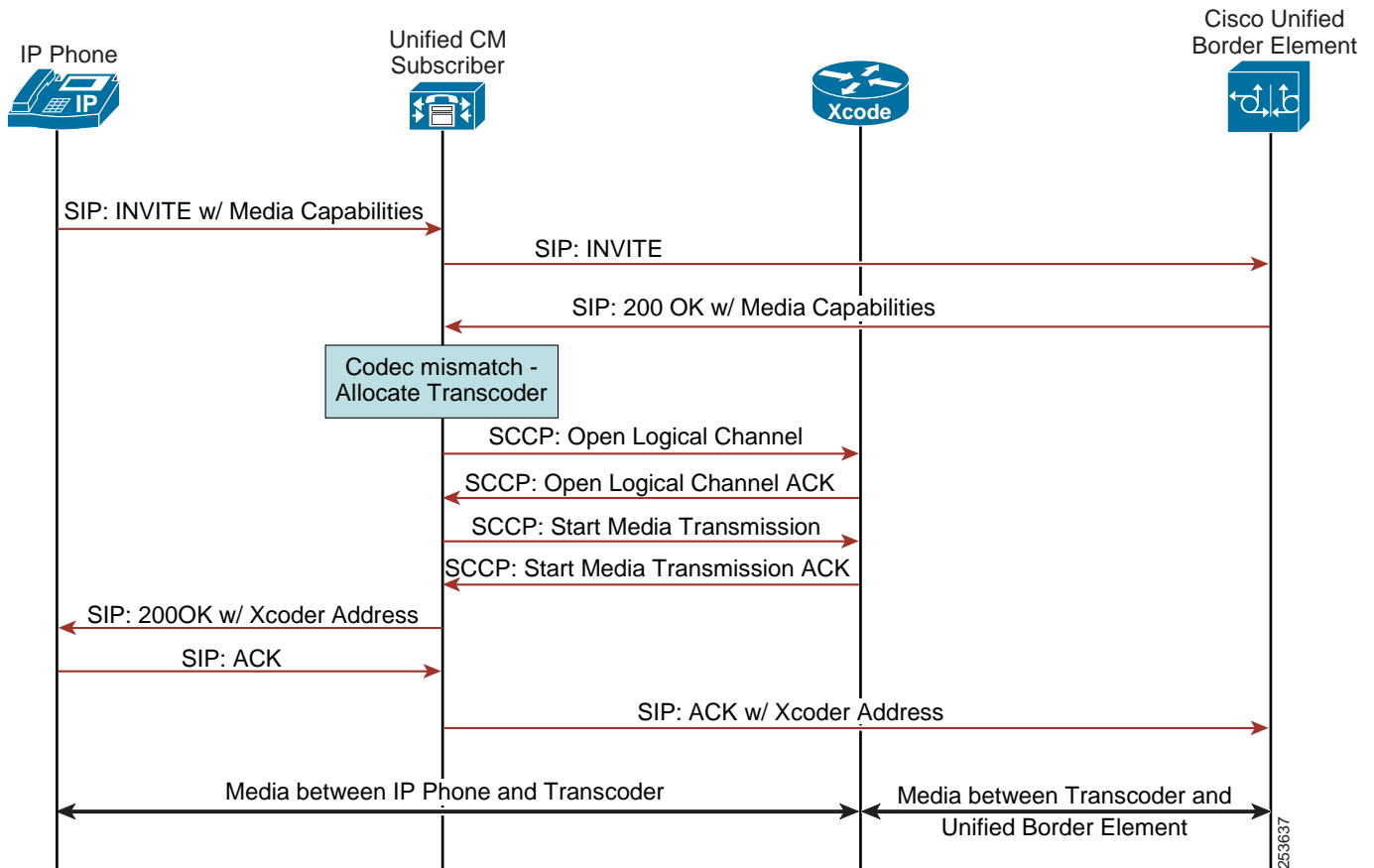

## Cisco IP Voice Media Streaming Application

The Cisco IP Voice Media Streaming Application provides the following software-based media resources:

- Conference bridge
- Music on Hold (MoH)
- Annunciator
- Media termination point (MTP)
- Interactive Voice Response (IVR)

When the IP Voice Media Streaming Application is activated, one of each of the above resources is automatically configured. Conferencing, annunciator, IVR, and MTP services can be disabled if required. If these resources are not needed, Cisco recommends that you disable them by modifying the appropriate service parameter in the Unified CM configuration. The service parameters have default settings for the maximum number of connections that each media device can handle. For details on how to modify the service parameters, refer to the appropriate version of the *Cisco Unified Communications Manager Administration Guide*, available at

[http://www.cisco.com/en/US/products/sw/voicesw/ps556/prod\\_maintenance\\_guides\\_list.html](http://www.cisco.com/en/US/products/sw/voicesw/ps556/prod_maintenance_guides_list.html)

Give careful consideration to situations that require multiple resources and to the load they place on the IP Voice Media Streaming Application. The media resources can reside on the same server as Unified CM or on a dedicated server not running the Unified CM call processing service. If your deployment requires more than the default number of any resource, Cisco recommends that you configure that resource to run on its own dedicated server. Cisco strongly recommends that you do not activate the Cisco IP Voice Streaming Media Application on a Cisco Unified CM node that has a high call processing load because it can adversely affect the performance of Cisco Unified CM. If heavy use of media resources is expected within a deployment, Cisco recommends deploying dedicated Unified CM media resource nodes (non-publisher nodes that do not perform call processing within the cluster) or relying on hardware-based media resources. Software-based media resources on Unified CM nodes are intended for small deployments or deployments where need for media resources is limited.

## Voice Termination

Voice termination applies to a call that has two call legs, one leg on a time-division multiplexing (TDM) interface and the second leg on a Voice over IP (VoIP) connection. The TDM leg must be terminated by hardware that performs encoding/decoding and packetization of the stream. This termination function is performed by a digital signal processor (DSP) resource residing in the same hardware module, blade, or platform.

All DSP hardware on Cisco TDM gateways is capable of terminating voice streams, and certain hardware is also capable of performing other media resource functions such as conferencing or transcoding (see [Transcoding, page 7-6](#) and [Transcoding, page 7-6](#)). The DSP hardware has either fixed DSP resources that cannot be upgraded or changed, or modular DSP resources that can be upgraded.

The number of supported calls per DSP depends on the computational complexity of the codec used for a call and also on the complexity mode configured on the DSP. Cisco IOS enables you to configure a complexity mode on the hardware module. Hardware platforms such as the PVDM2, PVDM3, and PVDM4 DSPs support three complexity modes: medium, high and flex mode. Some of the other hardware platforms support only medium and high complexity modes.

## Medium and High Complexity Mode

You can configure each DSP separately as either medium complexity, high complexity, or flex mode (PVDM3 DSPs and those based on C5510). The DSP treats all calls according to its configured complexity, regardless of the actual complexity of the codec of the call. A resource with configured complexity equal or higher than the actual complexity of the incoming call must be available, or the call will fail. For example, if a call requires a high-complexity codec but the DSP resource is configured for medium complexity mode, the call will fail. However, if a medium-complexity call is attempted on a DSP configured for high complexity mode, then the call will succeed and Cisco IOS will allocate a high-complexity mode resource.

## Flex Mode

Flex mode, available on hardware platforms that use the C5510 chipset and on PVDM3 DSPs, eliminates the requirement to specify the codec complexity at configuration time. A DSP in flex mode accepts a call of any supported codec type, as long as it has available processing power.

For C5510-based DSPs, the overhead of each call is tracked dynamically via a calculation of processing power in millions of instructions per second (MIPS). Cisco IOS performs a MIPS calculation for each call received and subtracts MIPS credits from its budget whenever a new call is initiated. The number of MIPS consumed by a call depends on the codec of the call. The DSP will allow a new call as long as it has remaining MIPS credits greater than or equal to the MIPS required for the incoming call.

Similarly, PVDM3 DSP modules use a credit-based system. Each module is assigned a fixed number of "credits" that represent a measure of its capacity to process media streams. Each media operation, such as voice termination, transcoding, and so forth, is assigned a cost in terms of credits. As DSP resources are allocated for a media processing function, its cost value is subtracted from the available credits. A DSP module runs out of capacity when the available credits run out and are no longer sufficient for the requested operation. The credit allocation rules for PVDM3 DSPs are rather complex.

Flex mode has an advantage when calls of multiple codecs must be supported on the same hardware because flex mode can support more calls than when the DSPs are configured as medium or high complexity. However, flex mode does allow oversubscription of the resources, which introduces the risk of call failure if all resources are used. With flex mode it is possible to have fewer DSP resources than with physical TDM interfaces.

Compared to medium or high complexity mode, flex mode has the advantage of supporting the most G.711 calls per DSP. For example, a PVDM2-16 DSP can support 8 G.711 calls in medium complexity mode or 16 G.711 calls in flex mode.

# Transcoding

A transcoder is a device that converts an input stream from one codec into an output stream that uses a different codec. Starting with Cisco IOS Release 15.0.1M, a transcoder also supports transrating, whereby it connects two streams that utilize the same codec but with a different packet size.

Transcoding from G.711 to any other codec is referred to as traditional transcoding. Transcoding between any two non-G.711 codecs is called universal transcoding and requires Universal Cisco IOS transcoders. Universal transcoding is supported starting with Cisco IOS Release 12.4.20T. Universal transcoding has a lower DSP density than traditional transcoding.

In a Unified CM system, the typical use of a transcoder is to convert between a G.711 voice stream and the low bit-rate compressed voice stream G.729a. The following cases determine when transcoder resources are needed:

- Single codec for the entire system

A single codec is generally used in a single-site deployment that usually has no need for conserving bandwidth. When a single codec is configured for all calls in the system, then no transcoder resources are required. In this scenario, G.711 is the most common choice that is supported by all vendors.

- Multiple codecs in use in the system, with all endpoints capable of all codec types

The most common reason for multiple codecs is to use G.711 for LAN calls to maximize the call quality and to use a low-bandwidth codec to maximize bandwidth efficiency for calls that traverse a WAN with limited bandwidth. Cisco recommends using G.729a as the low-bandwidth codec because it is supported on all Cisco Unified IP Phone models as well as most other Cisco Unified Communications devices, therefore it can eliminate the need for transcoding. Although Unified CM allows configuration of other low-bandwidth codecs between regions, some phone models do not support those codecs and therefore would require transcoders. They would require one transcoder for a call to a gateway and two transcoders if the call is to another IP phone. The use of transcoders is avoided if all devices support and are configured for both G.711 and G.729 because the devices will use the appropriate codec on a call-by-call basis.

- Multiple codecs in use in the system, and some endpoints support or are configured for G.711 only

This condition exists when G.729a is used in the system but there are devices that do not support this codec, or a device with G.729a support may be configured to not use it. In this case, a transcoder is also required. Devices from some third-party vendors may not support G.729.

A transcoder is also capable of performing the same functionality as a media termination point (MTP). In cases where transcoder functionality and MTP functionality are both needed, a transcoder is allocated by the system. If MTP functionality is required, Unified CM will allocate either a transcoder or an MTP from the resource pool, and the choice of resource will be determined by the media resource groups, as described in the section on [Media Resource Groups and Lists, page 7-35](#).

To finalize the design, it is necessary to know how many transcoders are needed and where they will be placed. For a multi-site deployment, Cisco recommends placing a transcoder local at each site where it might be required. If multiple codecs are needed, it is necessary to know how many endpoints do not support all codecs, where those endpoints are located, what other groups will be accessing those resources, how many maximum simultaneous calls these device must support, and where those resources are located in the network.

## Audio Transcoding Resources

Digital signal processor (DSP) resources are required to perform transcoding. The DSP resources can be located in the voice modules or in the on-board Cisco Packet Voice/Fax Digital Signal Processor (PVDM2, PVDM3, or PVDM4) slots available on the Cisco Integrated Services Routers (ISRs).

For more information on the voice gateway and its supported voice modules, refer the information on Cisco Voice Modules and Interface Cards available at

<http://www.cisco.com/c/en/us/products/interfaces-modules/voice-modules-interface-cards/index.html>

## Video Interoperability

Video interoperability is the audio and video support for point-to-point calls between Cisco TelePresence System (CTS) endpoints, other Cisco Unified Communications video endpoints, and third-party video endpoints. Prior to Cisco Unified CM 8.5, video interoperability between the various families of video endpoints was possible only with the insertion of a video component between endpoints, such as a video transcoder or a multipoint control unit (MCU).

Cisco Unified CM 8.5 and later releases not only offer native video interoperability between the various video endpoint family types, point-to-point, but also provide better video interoperability in general with H.264 codec negotiation in SIP and H.323 protocols and enable the endpoints to negotiate high definition (HD) resolutions when available. Video interoperability, however, is dependent on the endpoints to support the interoperation. For further information, refer to *Interoperability Between CTS Endpoints and Other Cisco Endpoints or Devices*, available at

[http://www.cisco.com/en/US/docs/telepresence/interop/endpoint\\_interop.html](http://www.cisco.com/en/US/docs/telepresence/interop/endpoint_interop.html)

## Media Termination Point (MTP)

A media termination point (MTP) is an entity that accepts two full-duplex media streams. It bridges the streams together and allows them to be set up and torn down independently. The streaming data received from the input stream on one connection is passed to the output stream on the other connection, and vice versa. MTPs have many possible uses, such as:

- [Re-Packetization of a Stream, page 7-7](#)
- [DTMF Conversion, page 7-8](#)
- Protocol-specific usage (bridging between IPv4 and IPv6 endpoints)
  - [Calls over SIP Trunks, page 7-9](#)
  - [H.323 Supplementary Services, page 7-13](#)
  - [H.323 Outbound Fast Connect, page 7-13](#)

## Re-Packetization of a Stream

An MTP can be used to transcode G.711 a-law audio packets to G.711 mu-law packets and vice versa, or it can be used to bridge two connections that utilize different packetization periods (different sample sizes).

## DTMF Conversion

DTMF tones are used during a call to signal to a far-end device for purposes of navigating a menu system, entering data, or other manipulation. They are processed differently than DTMF tones sent during a call setup as part of the call control. There are several methods for sending DTMF over IP, and two communicating endpoints might not support a common procedure. In these cases, Unified CM may dynamically insert an MTP in the media path to convert DTMF signals from one endpoint to the other. Unfortunately, this method does not scale because one MTP resource is required for each such call. The following sections help determine the optimum amount of MTP resources required, based on the combination of endpoints, trunks, and gateways in the system.

If Unified CM determines that an MTP needs to be inserted but no MTP resources are available, it uses the setting of the service parameter **Fail call if MTP allocation fails** to decide whether or not to allow the call to proceed. This service parameter is set to a default value of **False**. With this default configuration, an incoming call on a SIP Early Offer trunk would result in an outbound Delayed Offer.

## DTMF Relay Between Endpoints

The following methods are used to relay DTMF from one endpoint to another.

### Named Telephony Events (RFC 2833)

Named Telephony Events (NTEs) defined by RFC 2833 are a method of sending DTMF from one endpoint to another after the call media has been established. The tones are sent as packet data using the already established RTP stream and are distinguished from the audio by the RTP payload type field. For example, the audio of a call can be sent on a session with an RTP payload type that identifies it as G.711 data, and the DTMF packets are sent with an RTP payload type that identifies them as NTEs. The consumer of the stream utilizes the G.711 packets and the NTE packets separately.

### Key Press Markup Language (RFC 4730)

The Key Press Markup Language (KPML) is defined in RFC 4730. Unlike NTEs, which is an in-band method of sending DTMF, KPML uses the signaling channel (out-of-band, or OOB) to send SIP messages containing the DTMF digits.

KPML procedures use a SIP SUBSCRIBE message to register for DTMF digits. The digits themselves are delivered in NOTIFY messages containing an XML encoded body.

### Unsolicited Notify (UN)

Unsolicited Notify procedures are used primarily by Cisco IOS SIP Gateways to transport DTMF digits using SIP NOTIFY messages. Unlike KPML, these NOTIFY messages are unsolicited, and there is no prior registration to receive these messages using a SIP SUBSCRIBE message. But like KPML, Unsolicited Notify messages are out-of-band.

Also unlike KPML, which has an XML encoded body, the message body in these NOTIFY messages is a 10-character encoded digit, volume, and duration, describing the DTMF event.

### H.245 Signal, H.245 Alphanumeric

H.245 is the media control protocol used in H.323 networks. In addition to its use in negotiating media characteristics, H.245 also provides a channel for DTMF transport. H.245 utilizes the signaling channel and, hence, provides an out-of-band (OOB) way to send DTMF digits. The Signal method carries more information about the DTMF event (such as its actual duration) than does Alphanumeric.



### Cisco Proprietary RTP

This method sends DTMF digits in-band, that is, in the same stream as RTP packets. However, the DTMF packets are encoded differently than the media packets and use a different payload type. This method is not supported by Unified CM but is supported on Cisco IOS Gateways.

### Skinny Client Control Protocol (SCCP)

The Skinny Client Control Protocol is used by Unified CM for controlling the various SCCP-based devices registered to it. SCCP defines out-of-band messages that transport DTMF digits between Unified CM and the controlled device.

### DTMF Relay Between Endpoints in the Same Unified CM Cluster

The following rules apply to endpoints registered to Unified CM servers in the same cluster:

- Calls between two non-SIP endpoints do not require MTPs.

All Cisco Unified Communications endpoints other than SIP send DTMF to Unified CM via various signaling paths, and Unified CM forwards the DTMF between dissimilar endpoints. For example, an IP phone may use SCCP messages to Unified CM to send DTMF, which then gets sent to an H.323 gateway via H.245 signaling events. Unified CM provides the DTMF forwarding between different signaling types.

- Calls between two Cisco SIP endpoints do not require MTPs.

All Cisco SIP endpoints support NTE, so DTMF is sent directly between endpoints and no conversion is required.

- A combination of a SIP endpoint and a non-SIP endpoint might require MTPs.

To determine the support for NTE in your devices, refer to the product documentation for those devices. Support of NTE is not limited to SIP and can be supported in devices with other call control protocols. Unified CM has the ability to allocate MTPs dynamically on a call-by-call basis, based on the capabilities of the pair of endpoints.

## Calls over SIP Trunks

SIP trunk configuration is used to set up communication with a SIP User Agent such as another Cisco Unified CM cluster or a SIP gateway.

SIP negotiates media exchange via Session Description Protocol (SDP), where one side offers a set of capabilities to which the other side answers, thus converging on a set of media characteristics. SIP allows the initial offer to be sent either by the caller in the initial INVITE message (Early Offer) or, if the caller chooses not to, the called party can send the initial offer in the first reliable response (Delayed Offer).

By default, Unified CM SIP trunks send the INVITE without an initial offer (Delayed Offer).

Unified CM has the following three configurable options to enable a SIP trunk to send the offer in the INVITE (Early Offer):

### Media Termination Point Required

Enabling this option on the SIP trunk assigns an MTP for every outbound call. This option does not support codec pass-through mode, which imposes a single codec (G.711 or G.729) limitation over the SIP trunk, thus limiting media to voice calls only. With this option enabled, calls over the trunk uses MTPs assigned to the trunk rather than using calling device MTPs, which forces the media to follow the same signaling path.

**Note**

Enabling the **Media Termination Point Required** option on the SIP trunk increases MTP usage because an MTP is assigned for every inbound and outbound call rather than on an as-needed basis.

**Early Offer support for voice and video calls Mandatory (insert MTP if needed)**

Enabling this Unified CM configuration option on the SIP Profile associated with the SIP trunk inserts an MTP only if the calling device cannot provide Unified CM with the media characteristics required to create the outbound Early Offer (for example, where an inbound call to Unified CM is received on a Delayed Offer SIP trunk or a Slow Start H.323 trunk and on calls from older SCCP-based phones such as Cisco Unified IP Phones 7940 or 7960 registered to Unified CM). Unified CM creates a super-set of the endpoint and MTP codec capabilities and applies the codec filtering based on the applicable region-pair settings. The outbound Offer SDP will use the IP address and port number of the MTP and voice codec supported by the calling phone.

When Unified CM receives an inbound call on an H.323 Slow Start or SIP Delayed Offer trunk, the media capabilities of the calling device are not available when the call is initiated. In this case, Unified CM must insert an MTP and use its IP address and UDP port number to advertise all supported audio codecs (after region-pair filtering) in the Offer SDP of the initial INVITE sent over the outbound SIP trunk. When the Answer SDP is received on the SIP trunk, if it contains a codec that the calling endpoint supports, no additional offer-answer transaction is needed. In case of codec mismatch, Unified CM can either insert a transcoder to address the mismatch or send a Re-INVITE or UPDATE to trigger media negotiation. Calls from H.323 Slow Start or SIP Delayed Offer trunks support audio only in the initial call setup, but they can be upgraded mid-call to support video and SRTP if the call media is renegotiated (for example, after Hold/Resume).

When you configure **Early Offer support for voice and video calls Mandatory (insert MTP if needed)** on the SIP Profile of a trunk, calls from older SCCP-based phones, SIP Delayed Offer trunks, and H.323 Slow Start trunks cause Unified CM to allocate an MTP, if an MTP or transcoder is not already allocated for that call for another reason. The MTP is used to generate an Offer SDP with a valid media port number and IP address. The MTP is allocated from the media resources that are associated with the calling device rather than from the media resources of the outbound SIP trunk. (This prevents the media path from being anchored to the MTP of the outbound SIP trunk.) If the MTP cannot be allocated from the media resource group list (MRGL) of the calling device, the MTP allocation is attempted from the MRGL of the SIP trunk.

**Note**

If no MTP resources are available, the call will proceed as a Delayed Offer call.

Unified CM does not need to insert an MTP to create an outbound Early Offer call over a SIP trunk if Unified CM receives the inbound call by any of the following means:

- On a SIP trunk using Early Offer
- On an H.323 trunk using Fast Start
- On an MGCP trunk
- From a SIP-based IP phone registered to Unified CM

**Early Offer support for voice and video calls Best Effort (No MTP inserted)**

If this Unified CM SIP profile configuration option is enabled, the SIP trunk will never use MTPs to create an Early Offer but will send either an Early Offer or a Delayed Offer, depending on the capabilities of the calling device.

Best Effort Early Offer SIP trunks send outbound calls as Early Offer (INVITE with SDP content) in the following situations:

- An inbound call to Unified CM or SME is received over a SIP trunk using Early Offer.
- An inbound call to Unified CM or SME is received over an H.323 trunk using Fast Start.
- An inbound call to Unified CM or SME is received over an MGCP trunk.
- A call is initiated from a SIP-based IP phone registered to Unified CM.
- A call is initiated from a newer model SCCP-based Cisco Unified IP Phone registered to Unified CM.

Best Effort Early Offer trunks send outbound calls as Delayed Offer (INVITE without SDP content) in the following situations:

- An inbound call to Unified CM or SME is received over a Delayed Offer SIP trunk.
- An inbound call to Unified CM or SME is received over an H.323 Slow Start trunk.
- A call is initiated from an older model SCCP-based IP phone registered to Unified CM.

Calls over a Best Effort Early Offer SIP trunk support voice, video, and encrypted media.

In general, Cisco recommends **Early Offer support for voice and video calls Best Effort (No MTP inserted)** for all Unified CM and Unified CM Session Management Edition SIP trunks.

For more information on this option, refer to the section on [Best Effort Early Offer \[Early Offer support for voice and video calls Best Effort \(no MTP inserted\)\]](#), page 6-23.

## SIP Trunk MTP Requirements

By default, the SIP trunk parameter **Media Termination Point Required** and the SIP Profile parameter **Early Offer support for voice and video calls** are not selected.

Use the following steps to determine whether MTP resources are required for your SIP trunks.

1. Is the far-end SIP device defined by this SIP trunk capable of accepting an inbound call without a SIP Early Offer?  
  
If not, then on the SIP Profile associated with this trunk, select **Early Offer support for voice and video calls (insert MTP if needed)**. For outbound SIP trunk calls, an MTP will be inserted only if the calling device cannot provide Unified CM with the media characteristics required to create the Early Offer, or if DTMF conversion is needed.  
  
If yes, then select **Early Offer support for voice and video calls Best Effort (No MTP inserted)**, and use Step 2. to determine whether an MTP is inserted dynamically for DTMF conversion. Note that DTMF conversion can be performed by the MTP regardless of the codec in use.
2. Select a Trunk DTMF Signaling Method, which controls the behavior of DTMF selection on that trunk. Available MTPs will be allocated based on the requirements for matching DTMF methods for all calls.
  - a. DTMF Signaling Method: No Preference  
  
In this mode, Unified CM attempts to minimize the usage of MTP by selecting the DTMF signaling method supported by the endpoint.  
  
If both devices support RFC 2833, then no MTP is required.  
  
If both devices support any out-of-band DTMF mechanism, then Unified CM will use KPML over the SIP trunk. The only case where MTP is required is when one of the endpoints supports out-of-band only and the other supports RFC 2833 only.

If both devices support RFC 2833 and any out-of-band DTMF mechanism, then Unified CM negotiates both RFC 2833 and KPML but relies on RFC 2833 to receive the digits.



**Note** Unified CM does not negotiate to Unsolicited Notify if the SIP trunk is set to No Preference for its DTMF configuration. For example, if the far-end SIP gateway or Cisco Unified Border Element is configured for **dtmf-relay sip-notify** and the Unified CM SIP trunk to the Cisco Unified Border Element is set to No Preference, then DTMF will not work. The recommendation in this case is to set the Unified CM SIP trunk to OOB and RFC 2833 for the DTMF configuration, which will allow Unified CM to negotiate the Unsolicited Notify DTMF method with the SIP gateway or Cisco Unified Border Element.

b. DTMF Signaling Method: RFC 2833

By placing a restriction on the DTMF signaling method across the trunk, Unified CM is forced to allocate an MTP if any one or both the endpoints do not support RFC 2833. In this configuration, the only time an MTP will not be allocated is when both endpoints support RFC 2833.

c. DTMF Signaling Method: OOB and RFC 2833

In this mode, the SIP trunk signals both KPML and RFC 2833 DTMF methods across the trunk, and it is the most intensive MTP usage mode. The only cases where MTP resources will not be required is when both endpoints support RFC 2833 and any OOB DTMF method (KPML or SCCP).



**Note** Cisco Unified IP Phones play DTMF to the end user when DTMF is received via SCCP, but they do not play tones received by RFC 2833. However, there is no requirement to send DTMF to another end user. It is necessary only to consider the endpoints that originate calls combined with endpoints that might need DTMF, such as PSTN gateways, application servers, and so forth.

## DTMF Relay on SIP Gateways and Cisco Unified Border Element

Cisco SIP Gateways support KPML, NTE, or Unsolicited Notify as the DTMF mechanism, depending on the configuration. Because there may be a mix of endpoints in the system, multiple methods may be configured on the gateway simultaneously in order to minimize MTP requirements.

On Cisco SIP Gateways, configure both **sip-kpml** and **rtp-nte** as DTMF relay methods under SIP dial peers. This configuration will enable DTMF exchange with all types of endpoints, including those that support only NTE and those that support only OOB methods, without the need for MTP resources. With this configuration, the gateway will negotiate both NTE and KPML with Unified CM. If NTE is not supported by the Unified CM endpoint, then KPML will be used for DTMF exchange. If both methods are negotiated successfully, the gateway will rely on NTE to receive digits and will not subscribe to KPML.

Cisco SIP gateways also have the ability to use proprietary Unsolicited Notify (UN) method for DTMF. The UN method sends a SIP Notify message with a body that contains text describing the DTMF tone. This method is also supported on Unified CM and may be used if **sip-kpml** is not available. Configure **sip-notify** as the DTMF relay method. Note that this method is Cisco proprietary.

SIP gateways that support only NTE require MTP resources to be allocated when communicating with endpoints that do not support NTE.

## H.323 Trunks and Gateways

For the H.323 gateways and trunks there are three reasons for invoking an MTP:

- [H.323 Supplementary Services, page 7-13](#)
- [H.323 Outbound Fast Connect, page 7-13](#)
- [DTMF Conversion, page 7-13](#)

### H.323 Supplementary Services

MTPs can be used to extend supplementary services to H.323 endpoints that do not support the H.323v2 OpenLogicalChannel and CloseLogicalChannel request features of the Empty Capabilities Set (ECS). This requirement occurs infrequently. All Cisco H.323 endpoints support ECS, and most third-party endpoints have support as well. When needed, an MTP is allocated and connected into a call on behalf of an H.323 endpoint. When an MTP is required on an H.323 call and none is available, the call will proceed but will not be able to invoke supplementary services.

### H.323 Outbound Fast Connect

H.323 defines a procedure called Fast Connect, which reduces the number of packets exchanged during a call setup, thereby reducing the amount of time for media to be established. This procedure uses Fast Start elements for control channel signaling, and it is useful when two devices that are utilizing H.323 have high network latency between them because the time to establish media depends on that latency. Unified CM distinguishes between inbound and outbound Fast Start based on the direction of the call setup, and the distinction is important because the MTP requirements are not equal. For inbound Fast Start, no MTP is required. Outbound calls on an H.323 trunk do require an MTP when Fast Start is enabled. Frequently, it is only inbound calls that are problematic, and it is possible to use inbound Fast Start to solve the issue without also enabling outbound Fast Start.

### DTMF Conversion

An H.323 trunk supports the signaling of DTMF by means of H.245 out-of-band methods. H.323 intercluster trunks also support DTMF by means of NTE. There are no DTMF configuration options for H.323 trunks; Unified CM dynamically chooses the DTMF transport method.

The following scenarios can occur when two endpoints on different clusters are connected with an H.323 trunk:

- When both endpoints are SIP, then NTE is used. No MTP is required for DTMF.
- When one endpoint is SIP and supports both KPML and NTE, but the other endpoint is not SIP, then DTMF is sent as KPML from the SIP endpoint to Unified CM, and H.245 is used on the trunk. No MTP is required for DTMF.
- If one endpoint is SIP and supports only NTE but the other is not SIP, then H.245 is used on the trunk. An available MTP is allocated for the call. The MTP will be allocated on the Unified CM cluster where the SIP endpoint is located.

For example: A Cisco Unified IP Phone 7970 using SIP to communicate with a Cisco Unified IP Phone 7970 running SCCP, will use NTE when connected via a SIP trunk but will use OOB methods when communicating over an H.323 trunk (with the trunk using the H.245 method).

When a call is inbound from one H.323 trunk and is routed to another H.323 trunk, NTE will be used for DTMF when both endpoints are SIP. H.245 will be used if either endpoint is not SIP. An MTP will be allocated if one side is a SIP endpoint that supports only NTE and the other side is non-SIP.

## DTMF Relay on H.323 Gateways and Cisco Unified Border Element

H.323 gateways support DTMF relay via H.245 Alphanumeric, H.245 Signal, NTE, and audio in the media stream. The NTE option must not be used because it is not supported on Unified CM for H.323 gateways at this time. The preferred option is H.245 Signal. MTPs are required for establishing calls to an H.323 gateway if the other endpoint does not have signaling capability in common with Unified CM. For example, a Cisco Unified IP Phone 7960 running the SIP stack supports only NTEs, so an MTP is needed with an H.323 gateway.

## CTI Route Points

A CTI Route Point uses CTI events to communicate with CTI applications. For DTMF purposes, the CTI Route Point can be considered as an endpoint that supports all OOB methods and does not support RFC 2833. For such endpoints, the only instance where an MTP will be required for DTMF conversion would be when it is communicating with another endpoint that supports only RFC 2833.

CTI Route Points that have first-party control of a phone call will participate in the media stream of the call and require an MTP to be inserted. When the CTI has third-party control of a call so that the media passes through a device that is controlled by the CTI, then the requirement for an MTP is dependent on the capabilities of the controlled device.

### *Example 7-1 Call Flow that Requires an MTP for NTE Conversion*

Assume the example system has CTI route points with first-party control (the CTI port terminates the media), which integrate to a system that uses DTMF to navigate an IVR menu. If all phones in the system are running SCCP, then no MTP is required. In this case Unified CM controls the CTI port and receives DTMF from the IP phones via SCCP. Unified CM provides DTMF conversion.

However, if there are phones running a SIP stack (that support only NTE and not KPML), an MTP is required. NTEs are part of the media stream; therefore Unified CM does not receive them. An MTP is invoked into the media stream and has one call leg that uses SCCP, and the second call leg uses NTEs. The MTP is under SCCP control by Unified CM and performs the NTE-to-SCCP conversion. Note that the newer phones that do support KPML will not need an MTP.

## MTP Usage with a Conference Bridge

MTPs are utilized in a conference call when one or more participant devices in the conference use RFC 2833. When the conference feature is invoked, Unified CM allocates MTP resources for every conference participant device in the call that supports only RFC 2833. This is regardless of the DTMF capabilities of the conference bridge used.

## MTP Resources

The following types of devices are available for use as an MTP:

### Software MTP (Cisco IP Voice Media Streaming Application)

A software MTP is a device that is implemented by enabling the Cisco IP Voice Media Streaming Application on a Unified CM server. When the installed application is configured as an MTP application, it registers with a Unified CM node and informs Unified CM of how many MTP resources it supports. A software MTP device supports only G.711 streams or passthrough mode in a codec. The IP Voice Media Streaming Application is a resource that may also be used for several functions, and the design guidance must consider all functions together (see [Cisco IP Voice Media Streaming Application, page 7-4](#)).

### Software MTP (Based on Cisco IOS)

- The capability to provide a software-based MTP on the router is available beginning with Cisco IOS Release 12.3(11)T for the Cisco 3800 Series Routers; Release 15.0(1)M for the Cisco 2900 Series and 3900 Series Routers; Release IOS-XE for ASR1002, 1004, and 1006 Routers; Release IOS-XE 3.2 for ASR1001 Routers; and Release 12.3(8)T4 for other router models.
- This MTP allows configuration of any of the following codecs, but only one may be configured at a given time: G.711 mu-law and a-law, G.729a, G.729, G.729ab, G.729b, and passthrough. Some of these are not pertinent to a Unified CM implementation.
- Router configurations permit up to 1,000 individual streams, which support 500 transcoded sessions. This number of G.711 streams generates 10 Mbytes of traffic. The Cisco ISR G2s and ASR routers can support significantly higher numbers than this.

### Hardware MTP

DSP resources located in the voice modules or in the on-board Cisco Packet Voice/Fax Digital Signal Processor (PVDM2, PVDM3, or PVDM4) slots for Cisco Integrated Services Routers (ISRs) can also be used as MTP resource.

For more information on supported sessions with each PVDM module, refer the section on [Capacity Planning for Media Resources, page 7-31](#).



#### Note

When Cisco IOS MTP resources are invoked by Unified CM for a call flow, a software session rather than a hardware DSP session is consumed unless the media legs of the call flow require transrating. Thus, for flows invoking an MTP, a DSP session is used only when transrating (conversion between media legs with the same codec but different packetization times) is required.

## Trusted Relay Point

A Trusted Relay Point (TRP) is a device that can be inserted into a media stream to act as a control point for that stream. It may be used to provide further processing on that stream or as a method to ensure that the stream follows a specific desired path. There are two components to the TRP functionality, the logic utilized by Unified CM to invoke the TRP and the actual device that is invoked as the anchor point of the call. The TRP functionality can invoke an MTP device to act as that anchor point.

Unified CM provides a new configuration parameter for individual phone devices, which invokes a TRP for any call to or from that phone. The system utilizes the media resource pool mechanisms to manage the TRP resources. The media resource pool of that device must have an available device that will be invoked as a TRP.

See the chapter on [Network Infrastructure, page 3-1](#), for an example of a use case for the TRP as a QoS enforcement mechanism, and see the chapter on [Cisco Collaboration Security, page 4-1](#), for an example of utilizing the TRP as an anchor point for media streams in a redundant data center with firewall redundancy.

## Annunciator

An annunciator is a software function of the Cisco IP Voice Media Streaming Application that provides the ability to stream spoken messages or various call progress tones from the system to a user. It uses SCCP messages to establish RTP streams, and it can send multiple one-way RTP streams to devices such as Cisco IP phones or gateways. For most SIP devices, the call progress tones are downloaded (pushed) to the device at registration so that they can be invoked as needed by SIP signaling messages from Unified CM. Some SIP devices such as intercluster SIP trunks may still use an annunciator for call-progress tones. An annunciator may be used for verbal messages for almost any device regardless of whether it is using SIP or SCCP.

In some installations, it might be a requirement to establish a two-way media connection with an annunciator. To enable this capability, set the Cisco Unified CM service parameter **Duplex Streaming Enabled** to **True**. This may be required for firewall transversal or possibly for SIP early-offer scenarios.

Tones and announcements are predefined by the system. The announcements support localization and may also be customized by replacing the appropriate .wav file. The annunciator is capable of supporting G.711 a-law and mu-law, G.729, and Cisco L16 Wideband codecs without any transcoding resources.

The following features require an annunciator resource:

- Cisco Multilevel Precedence Preemption (MLPP)

This feature has streaming messages that it plays in response to the following call failure conditions.

- Unable to preempt due to an existing higher-precedence call.
- A precedence access limitation was reached.
- The attempted precedence level was unauthorized.
- The called number is not equipped for preemption or call waiting.



- Integration via SIP trunk

SIP endpoints have the ability to generate and send tones in-band in the RTP stream. Because SCCP devices do not have this ability, an annunciator is used in conjunction with an MTP to generate or accept DTMF tones when integrating with a SIP endpoint. The following types of tones are supported:

- Call progress tones (busy, alerting, reorder, and ringback)
- DTMF tones

- Cisco IOS gateways and intercluster trunks

These devices require support for call progress tone (ringback tone).

- System messages

During the following call failure conditions, the system plays a streaming message to the end user:

- A dialed number that the system cannot recognize
- A call that is not routed due to a service disruption
- A number that is busy and not configured for preemption or call waiting

- Conferencing

During a conference call, the system plays a barge-in tone to announce that a participant has joined or left the bridge.

An annunciator is automatically created in the system when the Cisco IP Voice Media Streaming Application is activated on a server. If the Media Streaming Application is deactivated, then the annunciator is also deactivated. A single annunciator instance can service the entire Unified CM cluster if it meets the performance requirements (see [Annunciator Performance, page 7-17](#)); otherwise, you must configure additional annunciators for the cluster. Additional annunciators can be added by activating the Cisco IP Voice Media Streaming Application on other servers within the cluster.

The annunciator registers with a single Unified CM at a time, as defined by its device pool and CM Group. It will automatically fail over to a secondary Unified CM if a secondary is configured for the device pool. Any announcement that is playing at the time of an outage will not be maintained.

An annunciator is considered a media device, and it can be included in media resource groups (MRGs) to control which annunciator is selected for use by phones and gateways.

### Annunciator Performance

By default, the annunciator is configured to support 48 simultaneous streams, which is the maximum recommended for an annunciator running on the same server (co-resident) with the Unified CM service. If the server has only 10 Mbps connectivity, lower the setting to 24 simultaneous streams.

For more information on supported annunciator sessions with each server platform, refer to the section on [Media Resources, page 25-28](#), in the chapter on [Collaboration Solution Sizing Guidance, page 25-1](#).

## Cisco RSVP Agent

In order to provide topology-aware call admission control, Unified CM invokes one or two RSVP Agents during the call setup to perform an RSVP reservation across the IP WAN. These agents are MTP or transcoder resources that have been configured to provide RSVP functionality. RSVP resources are treated the same way as regular MTPs or transcoders from the perspective of allocation of an MTP or transcoder resource by Unified CM.

The Cisco RSVP Agent feature was first introduced in Cisco IOS Release 12.4(6)T. For details on RSVP and Cisco RSVP Agents, refer to the chapter on [Bandwidth Management](#), page 13-1.

## Music on Hold

The Music on Hold (MoH) feature requires that each MoH server must be part of a Unified CM cluster and participate in the data replication schema. Specifically, the MoH server must share the following information with the Unified CM cluster through the database replication process:

- Audio sources - The number and identity of all configured MoH audio sources
- Multicast or unicast - The transport nature (multicast or unicast) configured for each of these sources
- Multicast address - The multicast base IP address of those sources configured to stream as multicast

To configure a MoH server, enable the Cisco IP Voice Media Streaming Application Service on one or more Unified CM nodes. An MoH server can be deployed along with Unified CM on the same server or in standalone mode.

## Unicast and Multicast MoH

Unified CM supports unicast and multicast MoH transport mechanisms.

A unicast MoH stream is a point-to-point, one-way audio Real-Time Transport Protocol (RTP) stream from the MoH server to the endpoint requesting MoH. It uses a separate source stream for each user or connection. Thus, if twenty devices are on hold, then twenty streams are generated over the network between the server and these endpoint devices. Unicast MoH can be extremely useful in those networks where multicast is not enabled or where devices are not capable of multicast, thereby still allowing an administrator to take advantage of the MoH feature. However, these additional MoH streams can potentially have a negative effect on network throughput and bandwidth.

A multicast MoH stream is a point-to-multipoint, one-way audio RTP stream between the MoH server and the multicast group IP address. The endpoints requesting an MoH audio stream can join the multicast group as needed. This mode of MoH conserves system resources and bandwidth because it enables multiple users to use the same audio source stream to provide music on hold. For this reason, multicast is an extremely attractive transport mechanism for the deployment of a service such as MoH because it greatly reduces the CPU impact on the source device and also greatly reduces the bandwidth consumption for delivery over common paths. However, multicast MoH can be problematic in situations where a network is not enabled for multicast or where the endpoint devices are not capable of handling multicast.

There are distinct differences between unicast and multicast MoH in terms of call flow behavior. A unicast MoH call flow is initiated by a message from Unified CM to the MoH server. This message tells the MoH server to send an audio stream to the holdee device's IP address. On the other hand, a multicast MoH call flow is initiated by a message from Unified CM to the holdee device. This message instructs

the endpoint device to join the multicast group address of the configured multicast MoH audio stream. A multicast MoH server continuously streams each of the configured multicast MoH audio sources, regardless of whether any callers are on hold.

Multicast MoH is available only for IPv4. Multicast for IPv6 is not currently supported by the MoH server.

For a detailed look at MoH call flows, see the section on [MoH Call Flows, page 7-24](#).

## MoH Selection Process

This section describes the MoH selection process as implemented in Unified CM.

The basic operation of MoH in a Cisco Unified Communications environment consists of a holder and a holdee. The *holder* is the endpoint user or network application placing a call on hold, and the *holdee* is the endpoint user or device placed on hold.

The MoH stream that an endpoint receives is determined by a combination of the User Hold MoH Audio Source of the device placing the endpoint on hold (holder) and the configured media resource group list (MRGL) of the endpoint placed on hold (holdee). The User Hold MoH Audio Source configured for the holder determines the audio file that will be streamed when the holder puts a call on hold, and the holdee's configured MRGL indicates the resource or server from which the holdee will receive the MoH stream.

As illustrated by the example in [Figure 7-3](#), if phones A and B are on a call and phone B (holder) places phone A (holdee) on hold, phone A will hear the MoH audio source configured for phone B (Audio-source2). However, phone A will receive this MoH audio stream from the MRGL (resource or server) configured for phone A (MRGL A).

**Figure 7-3** User Hold Audio Source and Media Resource Group List (MRGL)

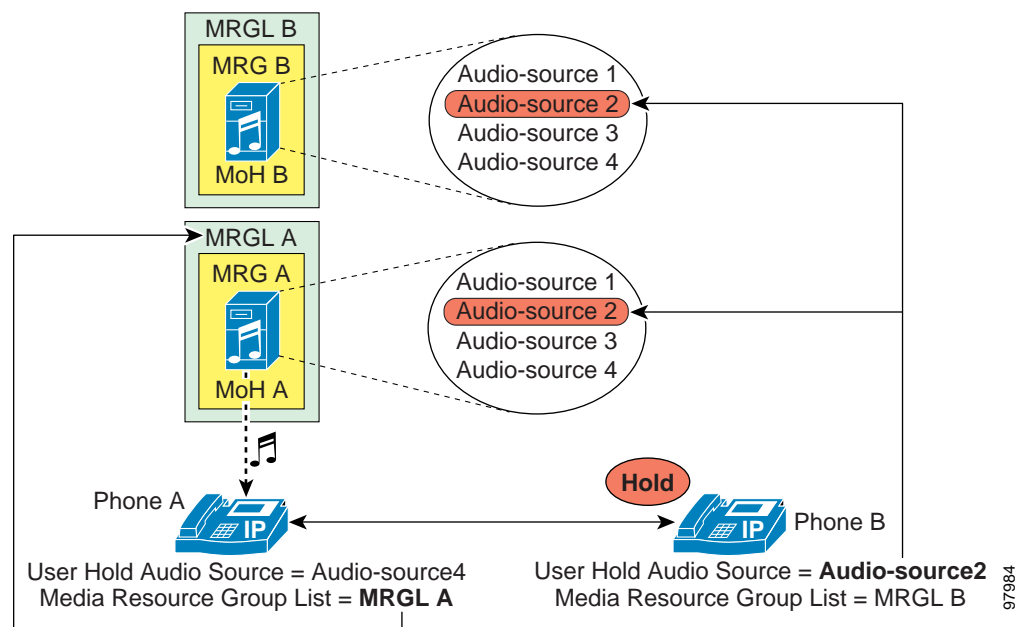

Because the configured MRGL determines the server from which a unicast-only device will receive the MoH stream, you must configure unicast-only devices with an MRGL that points to a unicast MoH resource or media resource group (MRG). Likewise, a device capable of multicast should be configured with an MRGL that points to a multicast MRG containing a MoH server configured for multicast.

## User and Network Hold

User hold includes the following types:

- User on hold at an IP phone or other endpoint device
- User on hold at the PSTN, where MoH is streamed to the gateway

Figure 7-4 shows these two types of call flows. If phone A is in a call with phone B and phone A (holder) pushes the Hold softkey, then a music stream is sent from the MoH server to phone B (holdee). The music stream can be sent to holdees within the IP network or holdees on the PSTN, as is the case if phone A places phone C on hold. In the case of phone C, the MoH stream is sent to the voice gateway interface and converted to the appropriate format for the PSTN phone. When phone A presses the Resume softkey, the holdee (phone B or C) disconnects from the music stream and reconnects to phone A.

Figure 7-4 Basic User Hold Example

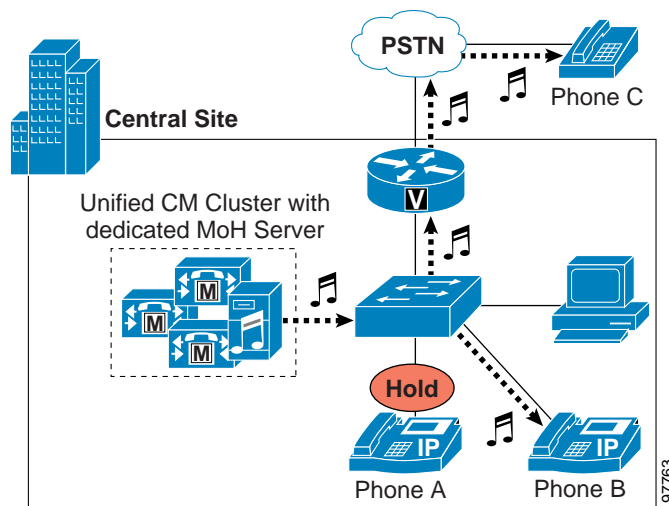

Network hold can occur in following scenarios:

- Call transfer
- Call Park
- Conference setup
- Application-based hold

Figure 7-5 illustrates an example of network hold during a call transfer. The call flow involves the following steps:

1. Phone A receives a call from PSTN phone C.
2. Phone A answers the call and then transfers it to phone B. During the transfer process, phone C is put on network hold.
3. Phone C receives an MoH stream from the MoH server via the gateway. After phone A completes the transfer action, phone C disconnects from the music stream and gets redirected to phone B.

This process is the same for other network hold operations such as call park and conference setup.

Figure 7-5 Basic Network Hold Example for Call Transfer

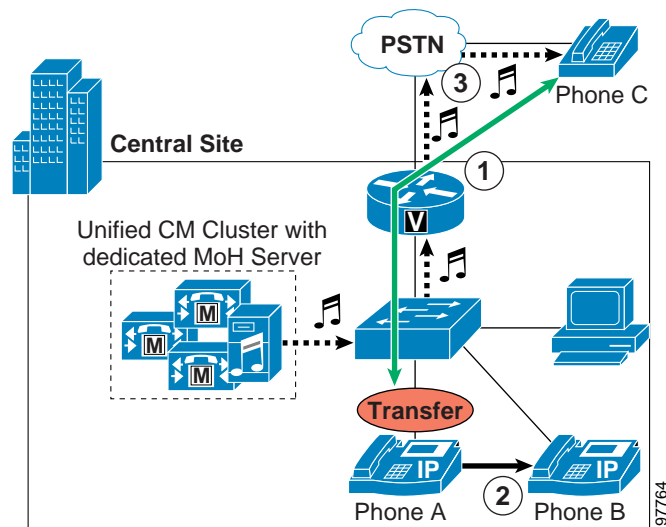

## MoH Sources

A Unified CM MoH server can generate a MoH stream from two types of sources:

- An audio file that has been uploaded to a Unified CM MoH server.
- A live fixed audio source or audio file from a Cisco IOS router or third-party device supporting multicast. Unified CM supports use of an external multicast audio source to provide live music on hold from external audio sources such as a CD, radio, jukebox, and so forth, as a Unified CM MoH audio source.

You can configure a maximum of 501 MoH audio sources per Unified CM cluster, of which one (the 51st) is identified as a fixed live source. An MoH server registers with the Unified CM cluster to provide IPv4 or dual-mode IPv4/IPv6 media address support.

### Audio File

Audio files (.wav format) can be uploaded to Unified CM, which then automatically generates MoH audio source files for the MoH codecs. Unified CM supports G711 (a-law and mu-law), G.729 Annex A, and Cisco L16 Wideband codecs for MoH streams. The uploaded audio file(s) should be in 16-bit PCM format or 8-bit G.711 (a-law/mu-law) format.

**Note**

Before configuring a MoH audio source, you must upload the .wav formatted audio source file to every MoH server within the cluster using the upload file function in the Unified CM Administration interface. Cisco recommends that you first upload the audio source file onto each MoH server in the cluster, then upload it onto the publisher (even if not an MoH server), and finally assign an MoH Audio Stream Number and configure the MoH audio source in the Unified CM Administration interface on the publisher. This ensures that each MoH server has the MoH audio file available when it is assigned to an MoH Audio Stream Number.

### Fixed Source

If recorded or live audio is needed, multicast MoH can be generated from a fixed live source connected to the analog interface of a Cisco IOS router or third-party device that supports multicast.

**Note**

Cisco Unified CM no longer supports a USB sound card for fixed live audio source connection to an MoH server due to lack of USB port support for MoH when Unified CM nodes are virtualized.

This mechanism enables you to use radios, CD players, or any other compatible sound source to stream multicast MoH. The stream from the fixed audio source is transcoded in real-time by the Cisco IOS router.

**Note**

Prior to using a fixed audio source to transmit music on hold, you should consider the legalities and the ramifications of re-broadcasting copyrighted audio materials. Consult your legal department for potential issues.

For more information on live MoH from a Cisco IOS router, refer the section on *MoH from a Live Feed* in the latest version of the *Cisco Unified SCCP and SIP SRST System Administrator Guide*, available at

[http://www.cisco.com/en/US/products/sw/voicesw/ps2169/products\\_installation\\_and\\_configuration\\_guides\\_list.html](http://www.cisco.com/en/US/products/sw/voicesw/ps2169/products_installation_and_configuration_guides_list.html)

## Rebroadcast External Multicast Source

Beginning with Cisco Unified CM 11.5, Cisco IOS routers can be configured to provide a multicast audio RTP stream from a .wav file or externally connected audio source. The audio source can be from a .wav file, CD player, radio, or other audio device connected to the Cisco IOS router.



### Note

This feature does not affect the existing Unified CM "fixed audio source" (#51). That source remains unchanged and can be used as a fixed live source or audio file multicast streamed from a Cisco IOS router.

This feature provides the capability to configure one or more external multicast source(s) within the Unified CM MOH audio source configuration option. With this feature, Unified CM receives one or more multicast RTP streams from a Cisco IOS router with external audio source connected. In turn Unified CM unicasts the received multicast RTP streams to held callers.

Within Unified CM MoH audio sources configuration, instead of configuring an MoH audio source to use a .wav file as the audio source, you can assign an external (multicast) IP: PORT to be used as the audio source. This allows callers to hear audio on hold streamed from an external multicast source connected to the E&M port of the Cisco IOS router. (See [Figure 7-6](#).) More than one Unified CM MoH audio source may use the same external multicast audio source.

**Figure 7-6** External Multicast MoH Source

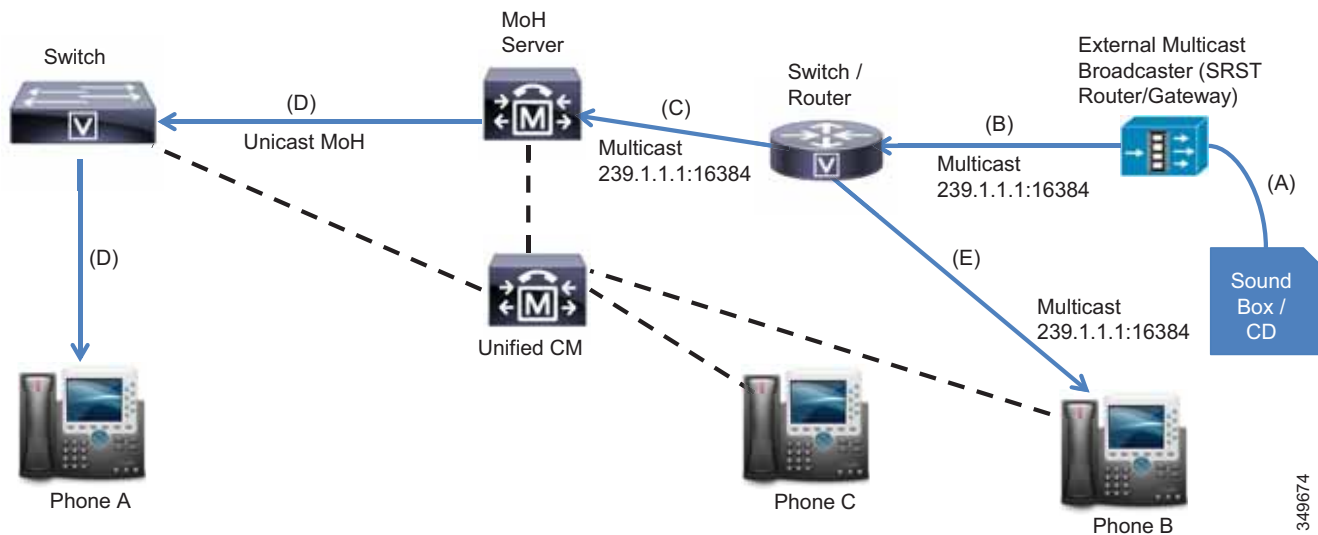

[Figure 7-6](#) shows the network flow when using external multicast MoH sources. As shown, the music source is connected (A) to a Cisco SRST Router's E&M port, which is configured to broadcast the audio to the network multicast group 239.1.1.1:16384 (B). The MoH Server is configured to receive the multicast group (C) and rebroadcast a unicast RTP MoH stream (D) to the held Phone A.

Optionally, the MoH server could have a configured audio source with the same multicast group address that the Cisco SRST router is using to broadcast the external audio source. If the multicast MoH server and the audio source are configured with the same multicast group address, when Phone B is placed on hold, it will receive the multicast RTP audio stream (E) from the original multicast stream (B) broadcast by the SRST router. In this case the MoH server does not send the audio because it is aware that the destination multicast IP address group is the same as the external audio source multicast stream (B) broadcast by the SRST router. It is also possible to specify a different multicast IP address for the audio source on Unified CM. In this case the MoH server would rebroadcast a separate multicast stream using the original multicast broadcast audio stream (C) it receives from the network.

## MoH Selection

To determine which User and Network Audio Source configuration setting to apply in a particular case, Unified CM interprets these settings for the *holder* device in the following priority order:

1. Directory or line setting (Devices with no line definition, such as gateways, do not have this level.)
2. Device setting
3. Common Device Configuration setting
4. Cluster-wide default setting

Unified CM also interprets the MRGL configuration settings of the *holdee* device in the following priority order:

1. Device setting
2. Device pool setting
3. System default MoH resources

Note that system default MoH resources are resources that are not assigned to any MRG and they are always unicast.

## MoH Call Flows

The following sections provide detailed illustrations and explanations of unicast and multicast MoH call flows for both SCCP and SIP endpoints. All call flows shown below depict MoH streaming for a Unified CM MoH server. Streaming multicast MoH from Cisco IOS routers is not shown, but the call flows in those multicast scenarios are generally the same as the multicast call flows for Unified CM MoH servers.

### SCCP Call Flows

This section describes the multicast and unicast call flows for music on hold with Skinny Client Control Protocol (SCCP) endpoints.

#### SCCP Multicast Call Flow

**Figure 7-7** illustrates a typical SCCP multicast call flow. As shown in the diagram, when the Hold softkey is pressed at phone A, Unified CM instructs both phone A and phone B to Close Receive Channel and Stop Media Transmission. This action effectively stops the RTP two-way audio stream.



Next, Unified CM tells phone B (the holdee) to Start Multicast Media Reception from multicast group address 239.192.240.1. The phone then issues an Internet Group Management Protocol (IGMP) V2 Membership Report message indicating that it is joining this group.

Figure 7-7 Detailed SCCP Multicast MoH Call Flow

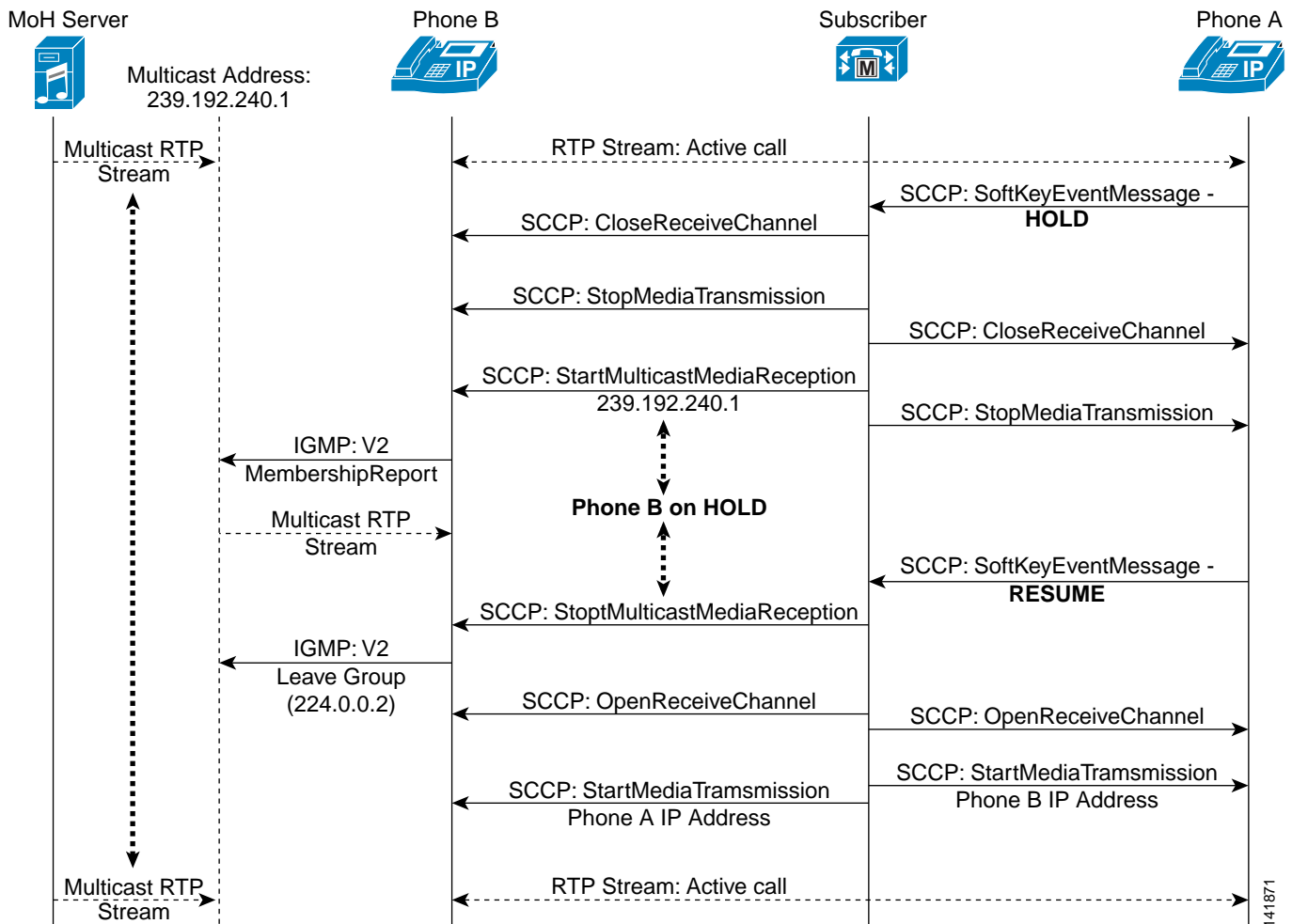

Meanwhile, the MoH server has been sourcing RTP audio to this multicast group address and, upon joining the multicast group, phone B begins receiving the MoH stream. Once phone A presses the Resume softkey, Unified CM instructs phone B to Stop Multicast Media Reception. Phone B then sends an IGMP V2 Leave Group message to 224.0.0.2 to indicate that the multicast stream is no longer needed. This effectively ends the MoH session. Next, Unified CM sends a series of Open Receive Channel messages to phones A and B, just as would be sent at the beginning of a phone call between the two phones. Soon afterwards, Unified CM instructs both phones to Start Media Transmission to each other's IP addresses. The phones are once again connected by means of an RTP two-way audio stream.

**Note**

The call flow diagrams in [Figure 7-7](#) and [Figure 7-8](#) assume that an initial call exists between phones A and B, with a two-way RTP audio stream. These diagrams are representative of call flows and therefore include only the pertinent traffic required for proper MoH operation. Thus, keep-alives, acknowledgments, and other miscellaneous traffic have been eliminated to better illustrate the interaction. The initial event in each diagram is the Hold softkey action performed by phone A.

**SCCP Unicast Call Flow**

[Figure 7-8](#) depicts an SCCP unicast MoH call flow. In this call flow diagram, when the Hold softkey is pressed at phone A, Unified CM instructs both phone A and phone B to Close Receive Channel and Stop Media Transmission. This action effectively stops the RTP two-way audio stream. Up to this point, unicast and multicast MoH call flows behave exactly the same way.

**Figure 7-8 Detailed SCCP Unicast MoH Call Flow**

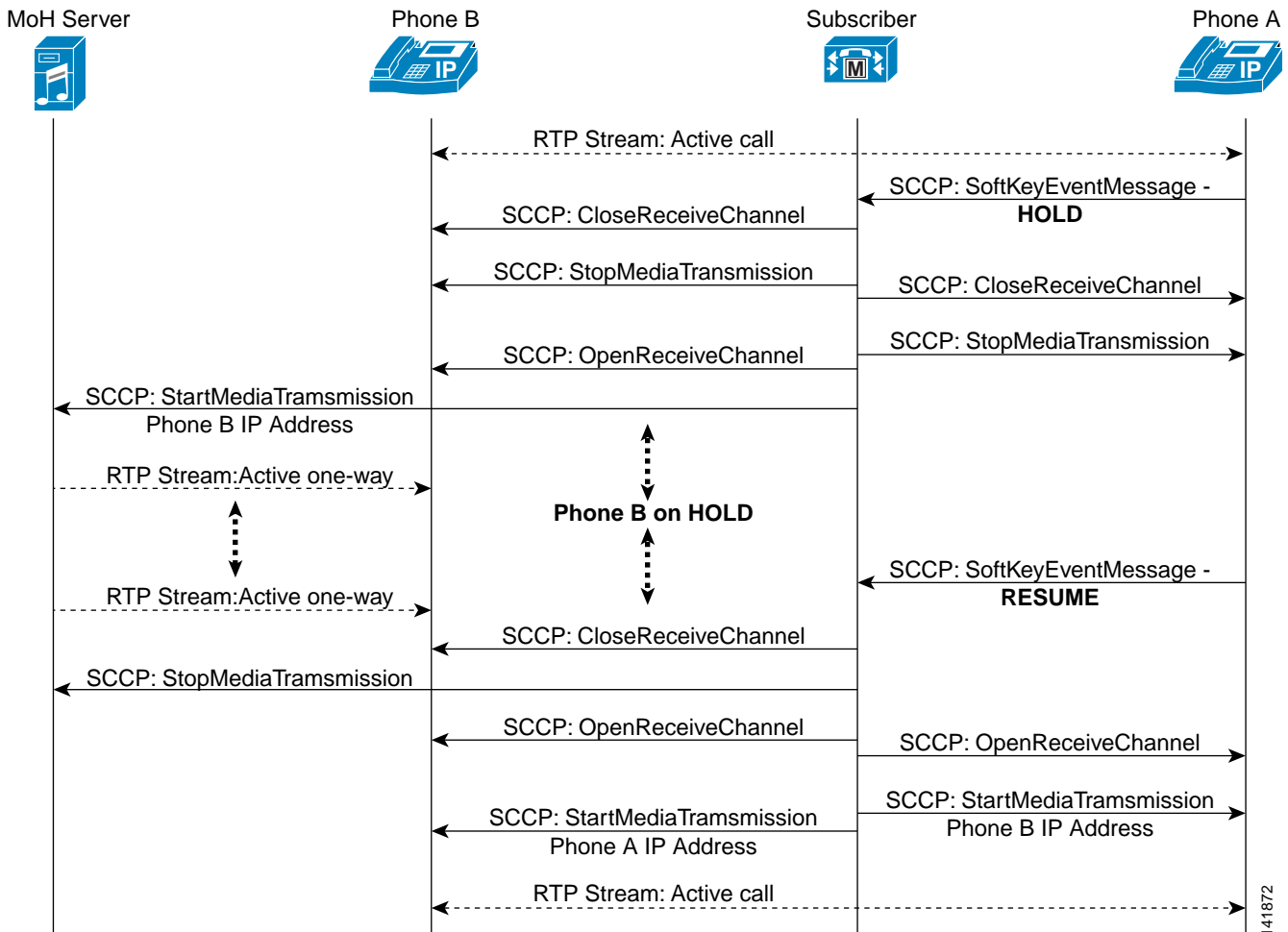

Next, Unified CM tells phone B (the holdee) to Open Receive Channel. (This is quite different from the multicast case, where Unified CM tells the holdee to Start Multicast Media Reception.) Then Unified CM tells the MoH server to Start Media Transmission to the IP address of phone B. (This too is quite different behavior from the multicast MoH call flow, where the phone is prompted to join a multicast group address.) At this point, the MoH server is sending a one-way unicast RTP music stream to phone B. When phone A presses the Resume softkey, Unified CM instructs the MoH server to Stop Media Transmission and instructs phone B to Close Receive Channel, effectively ending the MoH session. As with the multicast scenario, Unified CM sends a series of Open Receive Channel messages and Start Media Transmissions messages to phones A and B with each other's IP addresses. The phones are once again connected by means of an RTP two-way audio stream.

## SIP Call Flows

This section describes the multicast and unicast call flows for music on hold with Session Initiation Protocol (SIP) endpoints.

### SIP Multicast Call Flow

[Figure 7-9](#) illustrates a typical SIP multicast call flow. As shown in the diagram, when the Hold softkey is pressed at phone A, phone A sends a SIP INVITE with a Session Description Protocol (SDP) connection information indication of phone A's IP address and a media attribute indication of sendonly. Unified CM then instructs phone A to disconnect the RTP stream by means of a SIP 200 OK Response with an SDP connection information indication of 0.0.0.0 and a media attribute indication of recvonly. Phone B is then told to disconnect the RTP stream by means of a SIP INVITE from Unified CM with an SDP connection information indication of 0.0.0.0 and a media attribute of inactive. After a SIP 200 OK Response is sent back from phone B to Unified CM indicating an SDP media attribute of inactive, Unified CM then sends a SIP INVITE to phone B with an SDP connection information indication of the MoH multicast group address (in this case 239.23.1.1) and a media attribute of recvonly.

Figure 7-9 Detailed SIP Multicast MoH Call Flow

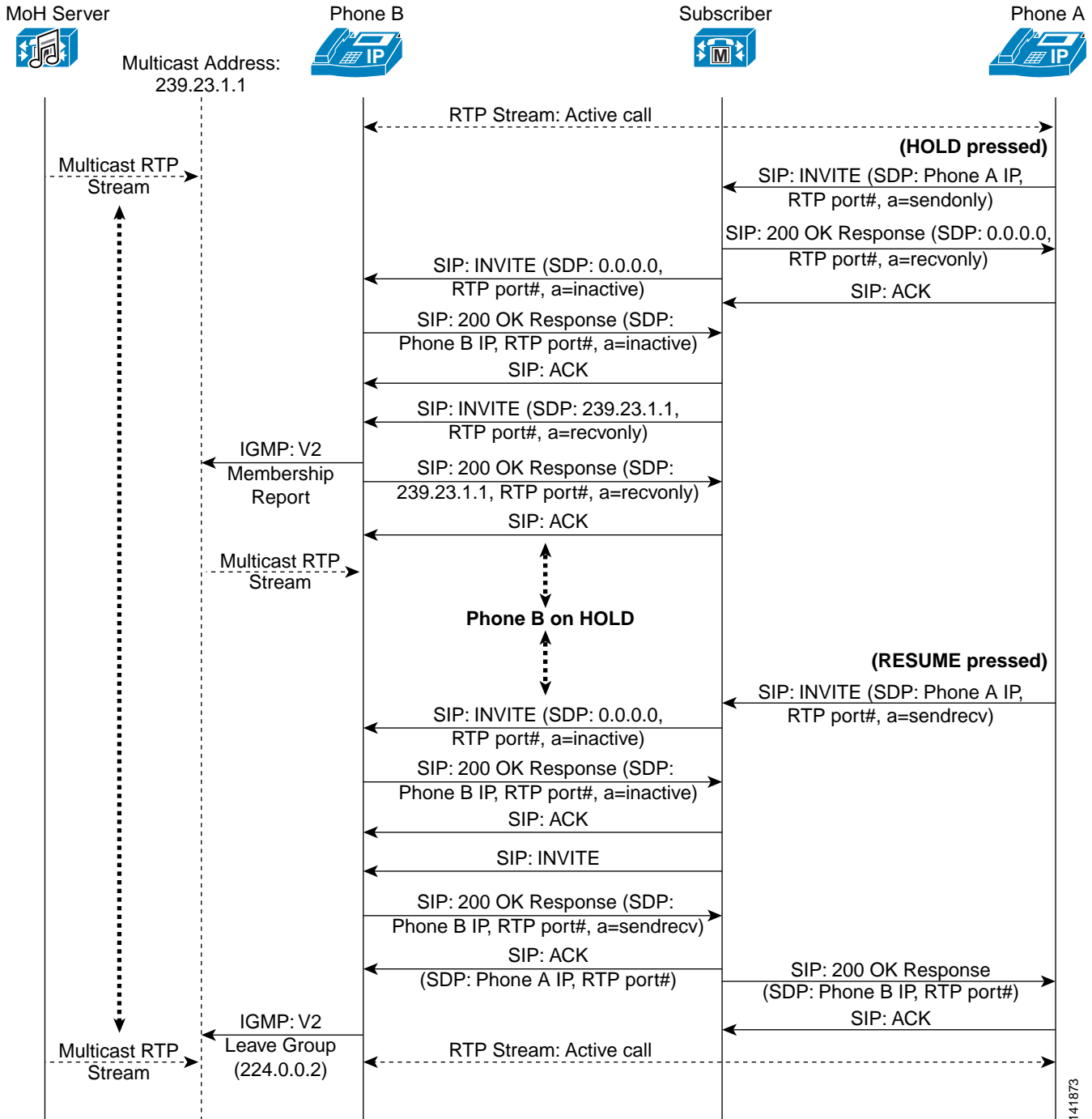

Next, phone B in Figure 7-9 issues an IGMP V2 Membership Report message indicating that it is joining this multicast group. In addition, phone B sends a SIP 200 OK Response back to Unified CM indicating an SDP media attribute of `recvonly` in response to the previous SIP INVITE. Meanwhile, the MoH server has been sourcing RTP audio to this MoH multicast group address and, upon joining the multicast group, phone B begins receiving the one-way MoH stream.

When the user at phone A presses the Resume softkey, phone A sends a SIP INVITE with an SDP connection information indication of phone A's IP address and media attribute indications of phone A's receiving RTP port and sendrecv. Unified CM then instructs phone B to disconnect from the multicast MoH stream by means of a SIP INVITE with an SDP connection information indication of 0.0.0.0 and a media attribute indication of inactive. A SIP 200 OK Response is sent back from phone B to Unified CM, indicating an SDP media attribute of inactive.

Next Unified CM sends a SIP INVITE to phone B, and phone B responds with a SIP 200 OK Response with an SDP connection information indication of phone B's IP address and media attribute indications of phone B's receiving RTP port and sendrecv. Unified CM responds by sending a SIP ACK to phone B with an SDP connection information indication of phone A's IP address and a media attribute of phone A's receiving RTP port number. Likewise, Unified CM forwards a SIP 200 OK Response to phone A's original resuming SIP INVITE, with an SDP connection information indication of phone B's IP address and a media attribute of phone B's receiving RTP port number. Phone B then sends an IGMP V2 Leave Group message to 224.0.0.2 to indicate that the multicast stream is no longer needed. Finally, the RTP two-way audio stream between phones A and B is reestablished.

**Note**

The call flow diagrams in [Figure 7-9](#) and [Figure 7-10](#) assume that an initial call exists between phones A and B, with a two-way RTP audio stream. These diagrams are representative of call flows and therefore include only the pertinent traffic required for proper MoH operation. Thus, keep-alives, some acknowledgements, progression indications, and other miscellaneous traffic have been eliminated to better illustrate the interaction. The initial event in each diagram is the Hold softkey action performed by phone A.

## SIP Unicast Call Flow

[Figure 7-10](#) depicts a SIP unicast MoH call flow. As shown in the diagram, when the Hold softkey is pressed at phone A, phone A sends a SIP INVITE with an SDP connection information indication of phone A's IP address and a media attribute indication of sendonly. Unified CM then instructs phone A to disconnect the RTP stream by means of a SIP 200 OK Response with an SDP connection information indication of 0.0.0.0 and a media attribute indication of recvonly. Phone B is then told to disconnect the RTP stream by means of a SIP INVITE from Unified CM, with an SDP connection information indication of 0.0.0.0 and a media attribute of inactive. Next a SIP 200 OK Response is sent back from phone B to Unified CM, indicating an SDP media attribute of inactive. Up to this point, unicast and multicast MoH call flows are exactly the same.

Figure 7-10 Detailed SIP Unicast MoH Call Flow

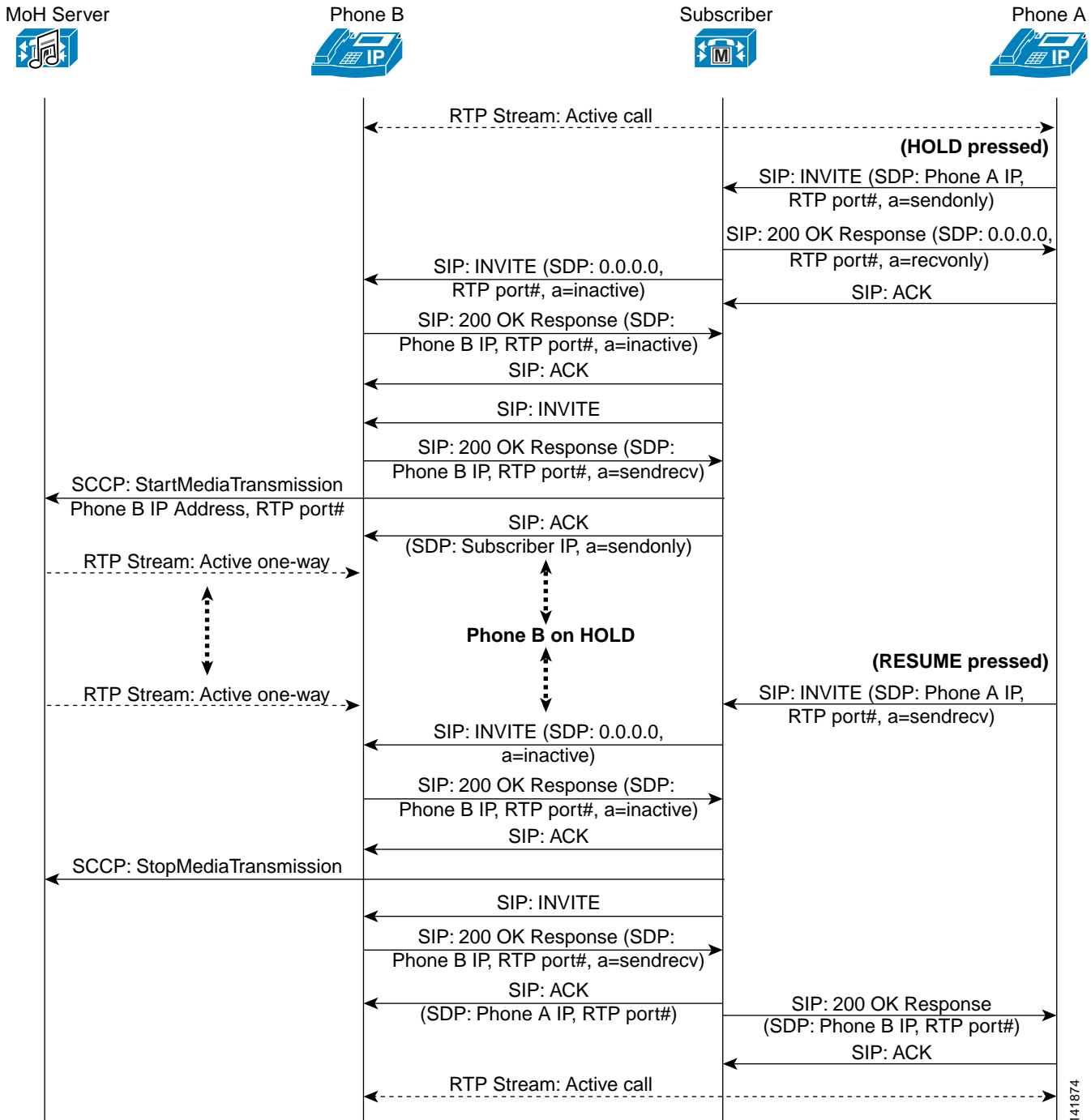

Unified CM then sends a SIP INVITE to phone B, and phone B responds back with a SIP 200 OK Response indicating SDP connection information with phone B's IP address and media attribute indications of phone B's receiving RTP port number and sendrecv. Unified CM then sends a SCCP StartMediaTransmission message to the MoH server, with phone B's address and receiving RTP port

number. This is followed by a SIP ACK from Unified CM to phone B indicating SDP connection information of the Unified CM IP address and a media attribute of `sendonly`. Meanwhile, the MoH server begins sourcing RTP audio to phone B, and phone B begins receiving the one-way MoH stream.

When the user at phone A presses the Resume softkey, phone A sends a SIP INVITE with an SDP connection information indication of phone A's IP address and media attribute indications of phone A's receiving RTP port and `sendrecv`. Unified CM then instructs phone B to disconnect from the multicast MoH stream by means of a SIP INVITE with an SDP connection information indication of `0.0.0.0` and a media attribute indication of `inactive`. A SIP 200 OK Response is sent back from phone B to Unified CM, indicating an SDP media attribute of `inactive`. Then Unified CM sends an SCCP `StopMediaTransmission` message to the MoH server, causing the MoH server to stop forwarding the MoH stream to phone B.

Next Unified CM sends a SIP INVITE to phone B, and phone B responds with a SIP 200 OK Response with an SDP connection information indication of phone B's IP address and media attribute indications of phone B's receiving RTP port and `sendrecv`. Unified CM responds by sending a SIP ACK to phone B, with an SDP connection information indication of phone A's IP address and a media attribute of phone A's receiving RTP port number. Likewise, Unified CM forwards a SIP 200 OK Response to phone A's original resuming SIP INVITE with an SDP connection information indication of phone B's IP address and a media attribute of phone B's receiving RTP port. Finally, the RTP two-way audio stream between phones A and B is reestablished.

### Duplex Unicast MoH Media Connections

Some scenarios require two-way media connections between held devices (holdee) and MoH servers. The Cisco Unified CM service parameter **Duplex Streaming Enabled** is available to enable this type of connection. The MoH server will discard any audio received from the held endpoints. For example, this **Duplex Streaming Enabled** option is needed when the MoH media stream must traverse through a firewall to reach the held device.

## Capacity Planning for Media Resources

This section provides information on the capacities of various network modules and chassis that carry DSPs, the capacities of the chassis to carry network modules, and software dependencies of the hardware.

For all Cisco ISR G1 and G2 capacity planning, use the DSP Calculator available at <http://www.cisco.com/go/dspcalculator>.

The DSP resources for Unified Communications solutions are provided by NM-HD, NM-HDV, and PVDM modules. NM-HD and NM-HDV2 modules are supported on Cisco ISR G1 and G2 Series platforms. Refer to the respective product data sheets for capacity information for these modules.

PVDM modules are available in four models: PVDM-256K, PVDM2, PVDM3, and PVDM4. Each of the models has several modules with different density support.

Some things to consider when doing capacity planning for hardware-based media resources include the density of the module, the underlying platform (Cisco ISR G1 or G2), and the minimum Cisco IOS version required.

For capacity information on PVDM2 modules, refer to the *High-Density Packet Voice Digital Signal Processor Module for Cisco Unified Communications Solutions* data sheet, available at

[http://www.cisco.com/en/US/prod/collateral/routers/ps5854/product\\_data\\_sheet0900aecd8016e845\\_ps3115\\_Products\\_Data\\_Sheet.html](http://www.cisco.com/en/US/prod/collateral/routers/ps5854/product_data_sheet0900aecd8016e845_ps3115_Products_Data_Sheet.html)

For capacity information on PVDM3 modules, refer to the PVDM3 provisioning information available at

[http://www.cisco.com/c/en/us/products/collateral/ios-nx-os-software/ios-ip-service-level-agreements-slas/whitepaper\\_C11-718333.html](http://www.cisco.com/c/en/us/products/collateral/ios-nx-os-software/ios-ip-service-level-agreements-slas/whitepaper_C11-718333.html)

For capacity information on PVDM4 modules, refer to the *Cisco Fourth-Generation Packet Voice Digital Signal Processor Module for Cisco Unified Communications Solutions Data Sheet*, available at

<http://www.cisco.com/c/en/us/products/routers/4000-series-integrated-services-routers-isr/datasheet-listing.html>

## Capacity Planning for Music on Hold

It is important to be aware of the hardware capacity for MoH resources and to consider the implications of multicast and unicast MoH in relation to this capacity when doing capacity planning for MoH resources. The capacity of the MoH server depends on several factors such as deployment model (co-resident or standalone), underlying server platform, and so forth.

### Co-resident and Standalone MoH

The MoH feature requires the use of a server that is part of a Unified CM cluster. You can configure the MoH server in either of the following ways:

- Co-resident deployment

The term *co-resident* refers to two or more services or applications running on the same server. In a co-resident deployment, the MoH feature runs on any server (either publisher or subscriber) in the cluster that is also running the Unified CM software.

- Standalone deployment

A standalone deployment, places the MoH feature on a dedicated media resource server node within the Unified CM cluster. This server acts as neither a publisher or a subscriber. That is, the Cisco IP Voice Media Streaming Application service is the only service enabled on the server. The only function of this dedicated server is to send MoH streams to devices within the network.

### Server Platform Limits

Cisco Unified Communications Manager supports a maximum of 1,000 MoH streams with Cisco Unified Computing System (UCS) C-Series or B-Series using the 7.5K or 10K Open Virtualization Archive (OVA) template for standalone deployments. For other platforms, Unified CM can support half that amount or less, depending upon what other services are active on the server. Ensure that network call volumes do not exceed these limits because, once MoH sessions have reached these limits, additional load could result in poor MoH quality, erratic MoH operation, or even loss of MoH functionality. Note that you can configure a maximum of 500 unique audio sources per Unified CM cluster.

For more information on supported MoH audio sources and sessions with each server platform, refer to the section on [Media Resources, page 25-28](#), in the chapter on [Collaboration Solution Sizing Guidance, page 25-1](#).



The following two MoH Server Configuration parameters affect MoH server capacity:

- **Maximum Half Duplex Streams**

This parameter determines the number of devices that can be placed on unicast MoH. By default this value is set to 250.

The Maximum Half Duplex Streams parameter should be set to the value derived from the following formula:

$$(\text{Server and deployment capacity}) - ((\text{Number of multicast MoH sources}) * (\text{Number of MoH codecs enabled}))$$

For example:

Cisco Unified Computing System (UCS) using 10K OVA standalone MoH server	Multicast MoH audio sources	MoH codecs enabled (G.711 mu-law and G.729)	Maximum half-duplex streams
1,000	- (12	* 2)	= <b>976</b>

Therefore, in this example, the Maximum Half Duplex Streams parameter would be configured with a value of no more than 976. Each of the multicast MoH audio sources will have an automatic multicast RTP stream created for each enabled MoH codec.

- **Maximum Multicast Connections**

This parameter determines the number of devices that can be placed on multicast MoH.

The Maximum Multicast Connections parameter should be set to a number that ensures that all devices can be placed on multicast MoH if necessary. Although the MoH server can generate only a finite number of multicast streams, a large number of held devices can join each multicast stream. This parameter should be set to a number that is greater than or equal to the number of devices that might be placed on multicast MoH at any given time. Typically multicast traffic is accounted for based on the number of streams being generated; however, Unified CM maintains a count of the actual number of devices placed on multicast MoH or joined to each multicast MoH stream. Although this method is different than the way multicast traffic is normally tracked, it is important to configure this parameter appropriately.

Failure to configure these parameters properly could lead to under-utilization of MoH server resources or failure of the server to handle the network load. For details on how to configure the service parameters, refer to the *Cisco Unified Communications Manager Administration Guide*, available at

[http://www.cisco.com/en/US/products/sw/voicesw/ps556/prod\\_maintenance\\_guides\\_list.html](http://www.cisco.com/en/US/products/sw/voicesw/ps556/prod_maintenance_guides_list.html)



**Note**

The maximum limit of 1,000 sessions per MoH server applies to unicast, multicast, or simultaneous unicast and multicast RTP streams. The limit represents the recommended maximum number of MoH streams a platform can support, irrespective of the transport mechanism.

## Resource Provisioning

When provisioning for co-resident or standalone MoH server configurations, network administrators should consider the type of transport mechanism used for the MoH audio streams. If using unicast MoH, each device on hold requires a separate MoH stream. However, if using multicast MoH and only a single audio source, then only a single MoH stream is required for each configured MoH codec type, no matter how many devices of that type are on hold.

For example, given a cluster with 30,000 phones and a 2% hold rate (only 2% of all endpoint devices are on hold at any given time), 600 MoH streams or sessions would be required. Given a unicast-only MoH environment, one co-resident (or standalone) MoH server running on a Cisco Unified Computing System (UCS) using the 10K OVA template would be required to handle this load.

By comparison, a multicast-only MoH environment with 36 unique MoH audio streams, for example, would require one co-resident MoH server. These 36 unique multicast streams could be provisioned in any one of the following ways:

- 36 unique audio sources streamed using a single codec
- 18 unique audio sources streamed using only 2 codecs
- 12 unique audio sources streamed using only 3 codecs
- 9 unique audio source streamed using all 4 codecs

In the preceding examples, the 2% hold rate is based on 30,000 phones and does not take into account gateways or other endpoint devices in the network that are also capable of being placed on hold. You should consider these other devices when calculating a hold rate because they could potentially be placed on hold just as the phones can.

The preceding calculations also do not provide for MoH server redundancy. If an MoH server fails or if more than 2% of the users go on hold at the same time, there are no other MoH resources in this scenario to handle the overflow or additional load. Your MoH resource calculations should include enough extra capacity to provide for redundancy. Additional MoH servers can be provisioned for redundancy or high availability as explained in the section on [High Availability for Media Resources, page 7-35](#).

# High Availability for Media Resources

The Unified CM constructs of media resource groups (MRGs) and media resource group lists (MRGLs) are used to control how the resources described in this chapter are organized and accessed. This section discusses considerations for how to utilize these constructs effectively.

## Media Resource Groups and Lists

Media resource groups (MRGs) and media resource lists (MRGLs) provide a method to control how resources are allocated that could include rights to resources, location of resources, or resource type for specific applications. This section assumes you have an understanding of media resource groups and lists, and it highlights the following design considerations:

- The system defines a default media resource group that is not visible in the user interface. All resources are members of this default MRG when they are created. When using MRGs to control access to resources, it is necessary to move the resources out of the default MRG by explicitly configuring them in some other MRG. If the desired effect is for resources to be available only as a last resort for all calls, then the resources may remain in the default group. Also, if no control over resources is necessary, they may remain in the default group.
- Consumers of media resources use resources first from any media resource group (MRG) or media resource group list (MRGL) that their configuration specifies. If the required resource is not available, the default MRG is searched for the resource. For simple deployments, the default MRG alone may be used.
- Use media resource groups (MRGs) and media resource group lists (MRGLs) to provide sharing of resources across multiple Unified CMs. If you do not use MRGs and MRGLs, the resources are available to a single Unified CM only.
- MRGLs will use MRGs in the order that they are listed in the configuration. If one MRG does not have the needed resource, the next MRG is searched. If all MRGs are searched and no resource is found, the search terminates.
- Within an MRG, resources are allocated based on their order in their configuration even though Unified CM Administration displays the devices in an MRG in alphabetical order. If you want media resources to be allocated in a specific order, Cisco recommends that you create a separate MRG for each individual resource and use MRGLs to specify the order of allocation.
- When there are multiple devices providing the same type of resource within an MRG, the algorithm for allocating that resource load-balances across all those devices. Cisco Unified CM uses a throttling mechanism to load balance across MTP and transcoder resources using the **MTP and Transcoder Resource Throttling Percentage** service parameter, which defines a percentage of the configured number of MTP or transcoder resources. When the number of active MTP or transcoder resources is equal to or greater than the percentage that is configured for this parameter, Cisco Unified CM stops sending calls to this resource and hunts through the MRGL (including the default MRG) one time to find a resource that uses matching codecs on both sides of the call. If Cisco Unified CM cannot find an available resource with matching codecs, it returns to the top of the MRGL to repeat the search, which then includes those resources that are in a throttled state and that match a smaller subset of capabilities for the call. Cisco Unified CM extends the call to the resource that is the best match for the call when such a resource is available. The call fails when Cisco Unified CM cannot allocate a resource for the call.

- Unified CM server-based software MTPs are pass-through enabled by default. Cisco IOS Enhanced MTP devices can be configured to support codec pass-through or non-codec pass-through modes. If a codec pass-through MTP is required and if, after the first iteration through the MRGL (including the default MRG), a codec pass-through MTP is not found, then there will be a second iteration that will ignore codec pass-through capabilities.
- An MRG may contain multiple types of resources, and the appropriate resource will be allocated from the group based on the feature needed. MTPs and transcoders are a special case because a transcoder may also be used as an MTP. For example, when both MTPs and transcoders exist in the same MRG and an MTP is required, the allocation is done based on the order in which the resources appear in the MRG. If transcoder devices appear earlier than MTPs in the MRG, transcoder resources will be allocated for the MTP requirement until the transcoder resources are exhausted and then the system will start allocating MTPs. For this reason, it is important to consider the order of resources when creating MRGs and MRGLs.
- MRGs can also be used to group resources of similar types. As explained in the example above, because a transcoder is a more expensive resource, Cisco recommends grouping transcoders and MTPs into separate MRGs and invoking the right resource by adding MRGs to the MRGL in appropriate order.
- You can also use MRGs and MRGLs to separate resources based on geographical location, thereby conserving WAN bandwidth whenever possible.
- Ensure that the media resources themselves have configurations that prevent further invocation of other media resources. For example, if an MTP is inserted into a call and the codec configured on that MTP does not match the one needed by Unified CM for the call, then a transcoder may also be invoked. A frequent mistake is to configure an MTP for G.729 or G.729b when Unified CM needs G.729a.

## Redundancy and Failover Considerations for Cisco IOS-Based Media Resources

A high availability design with media resources must include redundant media resources. When these resources are Cisco IOS-based, they can be distributed on more than one Cisco IOS platform to guard against failure of a single platform and they can be registered to different primary Unified CM servers.

Cisco IOS supports two modes of failover capability: graceful and immediate. The default failover method is graceful, in which the resources register to a backup Unified CM server only after all media activity has ceased. The immediate method, on the other hand, makes the resources register to the backup Unified CM server as soon as failure of the primary is detected. In situations where there is only one set of media resources with no redundancy, Cisco recommends use of the immediate failover method.

## High Availability for Transcoders

The following transcoder failover process takes place in the event that the Cisco Unified CM to which the device is registered becomes unavailable:

If the primary Unified CM fails, the transcoder device attempts to register with the secondary Unified CM node as defined in the Cisco Unified CM group for that device. The transcoder device will fall back to the primary Unified CM as soon it becomes available again. The calls that were on that Unified CM will register with the next Unified CM in the list.

## High Availability for Music on Hold

Cisco recommends that you configure and deploy multiple MoH servers for completely redundant MoH operation. If the first MoH server fails or becomes unavailable because it no longer has the resources required to service requests, the second server can provide continued MoH functionality. For proper redundant configuration, assign resources from at least two MoH servers to each MRG in the cluster.

In environments where both multicast and unicast MoH are required, be sure to provide redundancy for both transport types to ensure MoH redundancy for all endpoints in the network.

## Design Considerations for Media Resources

This section discusses specific considerations for deploying media resources for use with the various Unified CM deployment models. It also highlights the configuration considerations and best practices to help you design a robust solution for media resource allocation in your Unified CM implementation.

## Deployment Models

This section examines where and when the MTP and transcoding resources are used within the following three enterprise IP Telephony deployment models:

- [Single-Site Deployments, page 7-37](#)
- [Multisite Deployments with Centralized Call Processing, page 7-37](#)
- [Multisite Deployments with Distributed Call Processing, page 7-38](#)

### Single-Site Deployments

In a single-site deployment, there is no need for transcoding because there are no low-speed links to justify the use of a low bit-rate (LBR) codec. Some MTP resources might be required in the presence of a significant number of devices that are not compliant with H.323v2, such as older versions of Microsoft NetMeeting or certain video devices. MTP resources may be required for DTMF conversion if SIP endpoints are present (see [Named Telephony Events \(RFC 2833\), page 7-8](#).)

In a single-site deployment, if Unified CM receives an inbound call from an SCCP-based Cisco Unified IP Phone 7940 or 7960, the media capabilities of the calling device are not available when the call is initiated, and most of the SIP PSTN service providers require an early offer. In this case, Unified CM must insert an MTP and use its IP address and UDP port number to advertise all supported audio codecs (after region-pair filtering) in the Offer SDP of the initial INVITE sent over the outbound SIP trunk.

### Multisite Deployments with Centralized Call Processing

In a centralized call processing deployment, the Unified CM cluster and the applications (such as voice mail and IVR) are located at the central site, while several remote sites are connected through an IP WAN. The remote sites rely on the centralized Unified CMs to handle their call processing.

Because WAN bandwidth is typically limited, calls are configured to use a low bit-rate codec such as G.729 when traversing the WAN. (See [Figure 7-11](#).)

Voice compression between IP phones is easily configured through the use of *regions* and *locations* in Unified CM. A region defines the type of compression (for example, G.711 or G.729) used by the devices in that region, and a location specifies the total amount of bandwidth available for calls to and from devices at that location.

Figure 7-11 Transcoding for the WAN with Centralized Call Processing

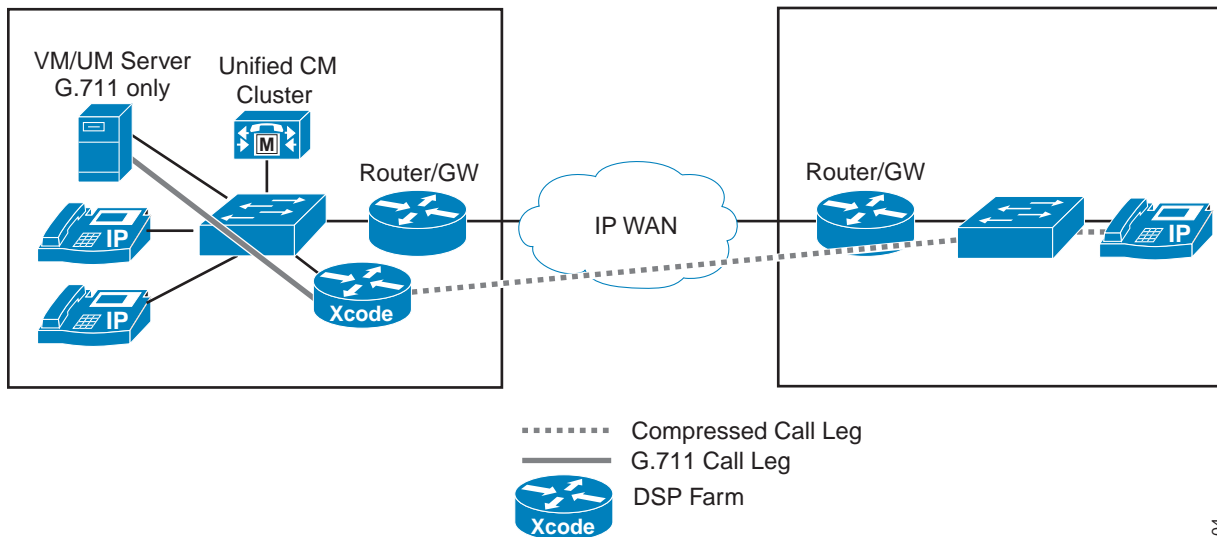

77304

Unified CM uses media resource groups (MRGs) to enable sharing of MTP and transcoding resources among the Unified CM servers within a cluster. In addition, when using an LBR codec (for example, G.729a) for calls that traverse different regions, the transcoding resources are used only if one (or both) of the endpoints is unable to use the LBR codec.

In [Figure 7-11](#), Unified CM knows that a transcoder is required and allocates one based on the MRGL and/or MRG of the device that is using the higher-bandwidth codec. In this case it is the VM/UM server that determines which transcoder device is used. This behavior of Unified CM is based on the assumption that the transcoder resources are actually located close to the higher-bandwidth device. If this system was designed so that the transcoder for the VM/UM server was located at the remote site, then G.711 would be sent across the WAN, which would defeat the intended design. As a result, if there are multiple sites with G.711-only devices, then each of these sites would need transcoder resources when an LBR is run on the WAN.

The placement of other resources is also important. For example, if a conference occurs with three phones at a remote site and the conference resource is located in the central (call processing) site, then three media streams are carried over the WAN. If the conference resource were local, then the calls would not traverse the WAN. It is necessary to consider this factor when designing the bandwidth and call admission control for your WAN.

## Multisite Deployments with Distributed Call Processing

In distributed call processing deployments, several sites are connected through an IP WAN. Each site contains a Unified CM cluster that can, in turn, follow the single-site model or the centralized call processing model. A gatekeeper may be used for call admission control between sites.

Because WAN bandwidth is typically limited, calls between sites may be configured to use an LBR codec (such as G.729a) when traversing the WAN. H.323v2 intercluster trunks are used to connect Unified CM clusters. Unified CM also supports compressed voice call connections through the MTP service if a hardware MTP is used. (See [Figure 7-12](#).)

A distributed call processing deployment might need transcoding and MTP services in the following situations:

- With current versions of Cisco applications, it is possible and recommended to avoid the use of transcoding resources. There might be specific instances where G.711 on a specific device cannot be avoided.
- Some endpoints (for example, video endpoints) do not support the H.323v2 features.

**Figure 7-12 Intercluster Call Flow with Transcoding**

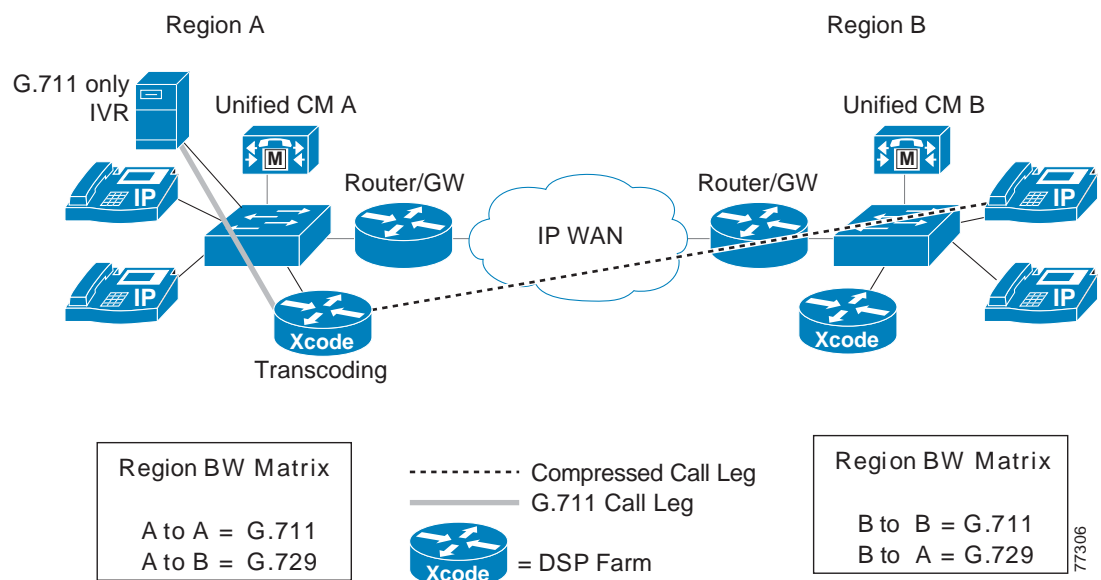

Unified CM uses media resource groups (MRGs) to enable sharing of MTP and transcoding resources among the Unified CM servers within a cluster. In addition, for calls across intercluster trunks, MTP and transcoding resources are used only when needed, thus eliminating the need to configure the MTP service for applications that do not support LBR codecs.

The following characteristics apply to distributed call processing deployments:

- Only the intercluster calls that require transcoding will use the MTP service. For example, if both endpoints of a call are capable of using a G.729 codec, no transcoding resources will be used.
- Sharing MTP resources among servers within a cluster provides more efficient resource utilization.

## Media Functions and Voice Quality

Any process that manipulates media can degrade the quality of the media. For example, encoding a voice stream for transmission across any network (IP or TDM) and decoding it at the other end will result in a loss of information, and the resulting voice stream will not be an exact reproduction of the original. If there are media traversal paths through the network that involve multiple encoding and decoding steps

of the same voice stream, then each successive encoding/decoding operation will further degrade the voice quality. In general, such paths should be avoided. This is especially true for low-bandwidth codecs (LBC) such as G.729.

If such paths cannot be avoided, voice quality can generally be improved by using a higher bandwidth, low-compression codec, such as the G.711 or G.722 codecs, which are recommended wherever such paths are anticipated. Use of lower bandwidth, higher compression codecs in such scenarios is not recommended.

## Music on Hold Design Considerations

This section highlights some MoH configuration considerations and best practice to help you design a robust MoH solution.

### Codec Selection

If you need multiple codecs for MoH deployment, configure them in the IP Voice Media Streaming Application service parameter **Supported MoH Codecs** under the Clusterwide Unified CM Service Parameters Configuration. From the Supported MoH Codecs list under the Clusterwide Parameters, select all the desired codec types that should be allowed for MoH streams. By default, only G.711 mu-law is selected. To select another codec type, click on it in the scrollable list. For multiple selections, hold down the CTRL key and use the mouse to select multiple codecs from the scrollable list. The actual codec used for a MoH event is determined by the Region settings of the MoH server and the device being put on hold (IP phone, gateway, and so forth). Therefore, assign the proper Region setting to your MoH servers and configure the desired Region Relationships to control the codec selection of MoH interactions.



#### Note

If you are using the G.729 codec for MoH audio streams, be aware that this codec is optimized for speech and it provides only marginal audio fidelity for music.

### Multicast Addressing

Proper IP addressing is important for configuring multicast MoH. Addresses for IP multicast range from 224.0.1.0 to 239.255.255.255. The Internet Assigned Numbers Authority (IANA), however, assigns addresses in the range 224.0.1.0 to 238.255.255.255 for public multicast applications. Cisco strongly discourages using public multicast addresses for music on hold. Instead, Cisco recommends that you configure multicast MoH audio sources to use IP addresses in the range 239.1.1.1 to 239.255.255.255, which is reserved for administratively controlled applications on private networks.

Furthermore, you should configure multicast audio sources to increment on the IP address and not the port number, for the following reasons:

- IP phones placed on hold join multicast IP addresses, not port numbers.

Cisco IP phones have no concept of multicast port numbers. Therefore, if all the configured codecs for a particular audio stream transmit to the same multicast IP address (even on different port numbers), all streams will be sent to the IP phone even though only one stream is needed. This has the potential of saturating the network with unnecessary traffic because the IP phone is capable of receiving only a single MoH stream.



- IP network routers route multicast based on IP addresses, not port numbers.

Routers have no concept of multicast port numbers. Thus, when it encounters multiple streams sent to the same multicast group address (even on different port numbers), the router forwards all streams of the multicast group. Because only one stream is needed, network bandwidth is over-utilized and network congestion can eventually result.

When configuring multiple multicast MoH servers, assign a different base multicast IP address and/or range to each MoH server. If multiple MoH servers are transmitting to the same multicast IP address, then when an endpoint joins the multicast group address, it will receive multiple MoH streams (from different MoH servers).

## Unified CM MoH Audio Sources

Configured audio sources are shared among *all* MoH servers in the Unified CM cluster, requiring each audio source file to be uploaded to every MoH server within the cluster. You can configure up to 500 unique audio sources per cluster.

For those audio sources that will be used for multicast streaming, ensure that **Allow Multicasting** is enabled.

## Unicast and Multicast in the Same Unified CM Cluster

In some cases, administrators might want to configure a single Unified CM cluster to handle both unicast and multicast MoH streams. This configuration might be necessary because the telephony network contains devices or endpoint that do not support multicast or because some portions of the network are not enabled for multicast.

Use one of the following methods to enable a cluster to support both unicast and multicast MoH audio streams:

- Deploy separate MoH servers, with one server configured as a unicast MoH server and the second server configured as a multicast MoH server.
- Deploy a single MoH server with two media resource groups (MRGs), each containing the same MoH server, with one MRG configured to use multicast for audio streams and the second MRG configured to use unicast.

In either case, you must configure at least two MRGs and at least two media resource group lists (MRGLs). Configure one unicast MRG and one unicast MRGL for those endpoints requiring unicast MoH. Likewise, configure one multicast MRG and one multicast MRGL for those endpoints requiring multicast MoH.

When deploying separate MoH servers, configure one server without multicast enabled (unicast-only) and configure a second MoH server with multicast enabled. Assign the unicast-only MoH media resource and the multicast-enabled MoH media resource to the unicast and multicast MRGs, respectively. Ensure that the **Use Multicast for MoH Audio** box is checked for the multicast MRG but not for the unicast MRG. Also assign these unicast and multicast MRGs to their respective MRGLs. In this case, an MoH stream is unicast or multicast based on whether the MRG is configured to use multicast and then on the server from which it is served.

When deploying a single MoH server for both unicast and multicast MoH, configure the server for multicast. Assign this same MoH media resource to both the unicast MRG and the multicast MRG, and check the **Use Multicast for MoH Audio** box for the multicast MRG. In this case, an MoH stream is unicast or multicast based solely on whether the MRG is configured to use multicast.

**Note**

When configuring the unicast MRG, do not be confused by the fact that the MoH media resource you are adding to this MRG has [Multicast] appended to the end of the resource name even though you are adding it to the unicast MRG. This label is simply an indication that the resource is capable of being multicast, but the **Use Multicast for MoH Audio** box determines whether the resource will use unicast or multicast.

In addition, you must configure individual devices or device pools to use the appropriate MRGL. You can place all unicast devices in a device pool or pools and configure those device pools to use the unicast MRGL. Likewise, you can place all multicast devices in a device pool or pools and configure those device pools to use the multicast MRGL. Optionally, you can configure individual devices to use the appropriate unicast or multicast MRGL. Lastly, configure a User Hold Audio Source and Network Hold Audio Source for each individual device or (in the case of phone devices) individual lines or directory numbers to assign the appropriate audio source to stream.

When choosing a method for deploying both multicast and unicast MoH in the same cluster, an important factor to consider is the number of servers required. When using a single MoH server for both unicast and multicast, fewer MoH servers are required throughout the cluster. Deploying separate multicast and unicast MoH servers will obviously require more servers within the cluster.

## Quality of Service (QoS)

Convergence of data and voice on a single network requires adequate QoS to ensure that time-sensitive and critical real-time applications such as voice are not delayed or dropped. To ensure proper QoS for voice traffic, the streams must be marked, classified, and queued as they enter and traverse the network to give the voice streams preferential treatment over less critical traffic. MoH servers automatically mark audio stream traffic the same as voice bearer traffic, with a Differentiated Services Code Point (DSCP) value of 46 or a Per Hop Behavior (PHB) value of EF (ToS of 0xB8). Therefore, as long as QoS is properly configured on the network, MoH streams will receive the same classification and priority queueing treatment as voice RTP media traffic.

Call signaling traffic between MoH servers and Unified CM servers is automatically marked with a DSCP value of 24 or a PHB value of CS3 (ToS of 0x60) by default. Therefore, as long as QoS is properly configured on the network, this call signalling traffic will be properly classified and queued within the network along with all other call signalling traffic.

## Call Admission Control and MoH

Call admission control (CAC) is required when IP telephony traffic is traveling across WAN links. Due to the limited bandwidth available on these links, it is highly probable that voice media traffic might get delayed or dropped without appropriate call admission control. For additional information, see [Bandwidth Management, page 13-1](#).

Call admission control for Unified CM (based on either static locations or RSVP-enabled locations) is capable of tracking unicast MoH streams traversing the WAN but not multicast MoH streams. Thus, even if WAN bandwidth has been fully subscribed, a multicast MoH stream will not be denied access to the WAN by call admission control. Instead, the stream will be sent across the WAN, likely resulting in poor audio stream quality and poor quality on all other calls traversing the WAN. To ensure that multicast MoH streams do not cause this over-subscription situation, you should over-provision the QoS configuration on all downstream WAN interfaces by configuring the low-latency queuing (LLQ) voice priority queue with additional bandwidth. Because MoH streams are uni-directional, only the voice priority queues of the downstream interfaces (from the central site to remote sites) must be

over-provisioned. Add enough bandwidth for every unique multicast MoH stream that might traverse the WAN link. For example, if there are four unique multicast audio streams that could potentially traverse the WAN, then add 96 kbps to the voice priority queue ( $4 * 24 \text{ kbps per G.729 audio stream} = 96 \text{ kbps}$ ).

Figure 7-13 shows an example of call admission control and MoH in a centralized multisite deployment. For this example, assume that IP phone C is in a call with a PSTN phone (phone B). At this point, no bandwidth has been consumed on the WAN. When phone C pushes the Hold softkey (step 1), phone B receives an MoH stream from the central-site MoH server by way of the WAN, thereby consuming bandwidth on the link. Whether or not this bandwidth is taken into consideration by call admission control depends on the type of MoH stream. If multicast MoH is streamed, then call admission control will not consider the 24 kbps being consumed (therefore, QoS on the downstream WAN interfaces should be provisioned accordingly). However, if unicast MoH is streamed, call admission control will subtract 24 kbps from the available WAN bandwidth (step 2).



**Note**

The preceding example might seem to imply that unicast MoH should be streamed across the WAN. However, this is merely an example used to illustrate locations-based call admission control with MoH and is not intended as a recommendation or endorsement of this configuration. As stated earlier, multicast MoH is the recommended transport mechanism for sending MoH audio streams across the WAN.

**Figure 7-13** Locations-Based Call Admission Control and MoH

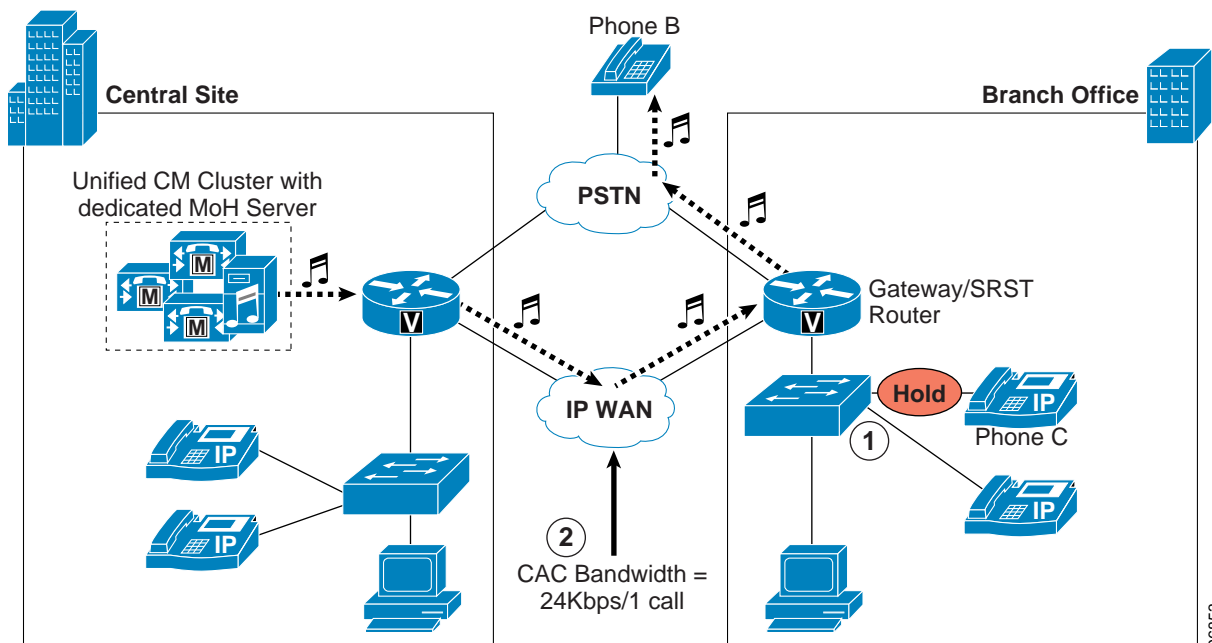

## Deployment Models for Music on Hold

The various Unified Communications call processing deployment models introduce additional considerations for MoH configuration design. Which deployment model you choose can also affect your decisions about MoH transport mechanisms (unicast or multicast), resource provisioning, and codecs. This section discusses these issues in relation to the various deployment models.

For more detailed information about the deployment models, see the chapter on [Collaboration Deployment Models, page 10-1](#).

### Single-Site Campus (Relevant to All Deployments)

Single-site campus deployments are typically based on a LAN infrastructure and provide sufficient bandwidth for large amounts of traffic. Because bandwidth is typically not limited in a LAN infrastructure, Cisco recommends the use of the G.711 (A-law or mu-law) codec for all MoH audio streams in a single-site deployment. G.711 provides the optimal voice and music streaming quality in an IP Telephony environment.

MoH server redundancy should also be considered. In the event that an MoH server becomes overloaded or is unavailable, configuring multiple MoH servers and assigning them in preferred order to MRGs ensures that another server can take over and provide the MoH streams.

With the increasing diversity of network technologies, in a large single-site campus it is likely that some endpoint devices or areas of the network will be unable to support multicast. For this reason, you might have to deploy both unicast and multicast MoH resources. For more information, see the section on [Unicast and Multicast in the Same Unified CM Cluster, page 7-41](#).

To ensure that off-net calls and application-handled calls receive expected MoH streams when placed on hold, configure all gateways and other devices with the appropriate MRGLs and audio sources, or assign them to appropriate device pools.

### Centralized Multisite Deployments

Multisite IP telephony deployments with centralized call processing typically contain WAN connections to multiple non-central sites. These WAN links usually cause bandwidth and throughput bottlenecks. To minimize bandwidth consumption on these links, Cisco recommends the use of the G.729 codec for all MoH audio streams traversing the WAN. Because the G.729 codec is optimized for voice and not music applications, you should use G.729 only across the WAN, where the bandwidth savings far outweighs the lower quality afforded by G.729 for MoH transport. Likewise, because multicast traffic provides significant bandwidth savings, you should always use multicast MoH when streaming audio to endpoints across the WAN.

If the sound quality of an MoH stream becomes an issue when using the G.729 codec across the WAN, you can use the G.711 codec for MoH audio streams across the WAN while still using G.729 for voice calls. In order to send MoH streams across the WAN with the G.711 codec but voice calls across the WAN with the G.729 codec, place all MoH servers in a Unified CM region by themselves, and configure that region to use G.711 between itself and all other regions. Thus, when a call is placed between two phones on either side of a WAN, the G.729 codec is used between their respective regions. However, when the call is placed on hold by either party, the MoH audio stream is encoded using G.711 because G.711 is the configured codec to use between the MoH server's region and the region of the phone placed on hold.

## Centralized PSTN Deployments

In a centralized PSTN deployment with a single gateway or set of gateways for PSTN access, there is no way to configure more than 500 unique audio sources. The media resource group list (MRGL) assigned to the gateway determines the MoH server used for MoH streaming when a PSTN caller is placed on hold, while the phone placing the call on hold determines the audio source. With a centralized PSTN deployment, because there are no PSTN gateways at the local sites, an MRGL cannot be used to point to multiple MoH servers based on branch location. Thus, in this case there are at most 500 unique site-specific MoH sources or multicast streaming addresses to enable unique MoH sources for a maximum of 500 branch sites.

The following example illustrates how MoH streaming works for up to 500 locations:

For branches 1 to 500, the centralized PSTN gateway or set of gateways is/are configured with MRGL pointing to MoH server node MoH\_1 (with base multicast address of 239.1.1.1), with all phones at each branch pointing to one of the 500 audio sources configured on the cluster. Thus, phones in Branch 1 point to audio source 1, which on MoH\_1 server is 239.1.1.1 to 4 (depending on codec and assuming audio sources are configured in order); phones in Branch 2 point to audio source 2, which on MoH\_1 server is 239.1.1.5 to 8; phones in Branch 3 point to audio source 3, which on MoH\_1 server is 239.1.1.9 to 12; and so on up to phones in Branch 500 pointing to audio source 501, which on MoH\_1 server is 239.1.8.197 to 200.

## Multicast MoH from Branch Routers

Branch routers deployed with the Cisco Unified Survivable Remote Site Telephony (SRST) feature can provide multicast MoH in a remote or branch site, with the MoH streaming from the branch SRST router's flash or from a live feed connected to an analog port. Multicast MoH from a branch router via these two methods enhances the Unified CM MoH feature in both of the following scenarios:

- Non-Fallback Mode

When the WAN is up and the phones are controlled by Unified CM, this configuration can eliminate the need to forward MoH across the WAN to remote branch sites by providing locally sourced MoH.

- Fallback Mode

When SRST is active and the branch devices have lost connectivity to the central-site Unified CM, the branch router can continue to provide multicast MoH.

When using the live feed option in either scenario, the SRST router provides redundancy by monitoring the live feed input, and it will revert to streaming MoH from a file in flash if the live feed is disconnected. You can use only a single multicast address and port number per SRST router to provide multicast MoH; therefore, the SRST router does not support streaming from both the live feed and the flash file at the same time. In addition, the SRST router can stream only a single audio file from flash.



### Note

An SRST license is required regardless of whether the SRST functionality will actually be used. The license is required because the configuration for streaming MoH from branch router flash is done under the SRST configuration mode and, even if SRST functionality will not be used, at least one **max-ephones** and one **max-dn** must be configured.

### Non-Fallback Mode

During non-fallback mode (when the WAN is up and SRST is not active), the branch SRST or E-SRST router can provide multicast MoH to all local Cisco Unified Communications devices. To accomplish this, you must configure a Unified CM MoH server with an audio source that has the same multicast IP

address and port number as configured on the branch router. The audio source multicast IP address and port number used on the branch router can correspond to the multicast address and port number of either an audio source file or the fixed audio source of the centralized Unified CM MoH server. In this scenario, because the multicast MoH audio stream is always coming from the SRST or E-SRST router, it is not necessary for the central-site MoH server audio source to traverse the WAN.

To prevent the central-site audio stream(s) from traversing the WAN, use one of the following methods:

- Configure a maximum hop count
  - Configure the central-site MoH audio source with a maximum hop count (or TTL) low enough to ensure that it will not stream further than the central-site LAN.
- Configure an access control list (ACL) on the WAN interface
  - Configure an ACL on the central-site WAN interface to disallow packets destined to the multicast group address(es) from being sent out the interface.
- Disable multicast routing on the WAN interface
  - Do not configure multicast routing on the WAN interface, thus ensuring that multicast streams are not forwarded into the WAN.

Figure 7-14 illustrates streaming multicast MoH from a branch router when it is not in fallback mode. After phone A places phone C on hold, phone C receives multicast MoH from the local SRST router. In this example, the MoH server is streaming a multicast audio source to 239.192.240.1 (on RTP port 16384); however, this stream has been limited to a maximum hop of one (1) to ensure that it will not travel off the local MoH server's subnet and across the WAN. At the same time, the branch office SRST router/gateway is multicasting an audio stream from either flash or a live feed. This stream is also using 239.192.240.1 as its multicast address and 16384 as the RTP port number. When phone A presses the Hold softkey, phone C receives the MoH audio stream sourced by the SRST router.

Figure 7-14 Multicast MoH from Branch Router

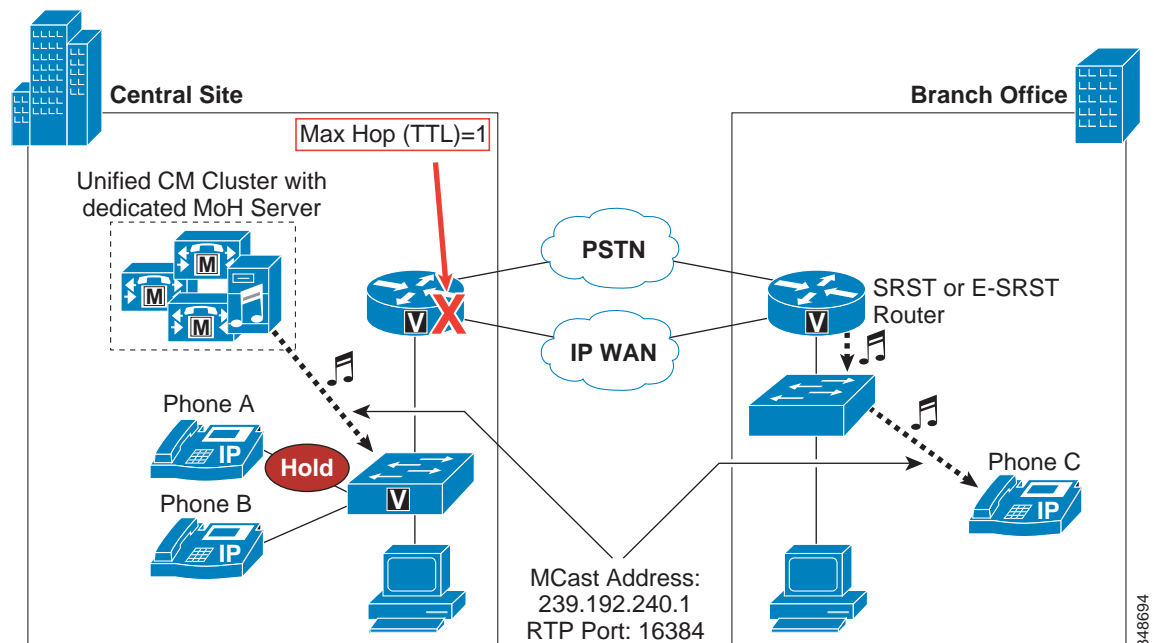

When using this method for delivering multicast MoH, configure all devices within the Unified CM cluster to use the same user hold and network hold audio source and configure all branch routers with the same multicast group address and port number. Because the user or network hold audio source of the holder is used to determine the audio source, if you configure more than one user or network hold audio source within the cluster, there is no way to guarantee that a remote holder will always receive the local MoH stream. For example, suppose a central-site phone is configured with an audio source that uses group address 239.192.254.1 as its user and network hold audio source. If this phone places a remote device on hold, the remote device will attempt to join 239.192.254.1 even if the local router flash MoH stream is sending to multicast group address 239.192.240.1. If instead all devices in the network are configured to use the user/network hold audio source with multicast group address 239.192.240.1 and all branch routers are configured to multicast from flash on 239.192.240.1, then every remote device will receive the MoH from its local router.

## Fallback Mode

During fallback mode (when the WAN is down and SRST is active), the branch SRST router can stream multicast MoH to all analog and digital ports within the chassis, thereby providing MoH to analog phones and PSTN callers.

The branch router's configuration for fallback mode multicast MoH is the same as the normal operation configuration. However, which multicast address you configure on the router depends on the intended operation. If you want the branch router to provide multicast MoH to devices only in fallback mode (for example, if MoH received by remote devices is to be sourced from the central-site MoH server during non-fallback mode), then the multicast address and port number configured on the SRST router should not overlap with any of the central-site MoH server audio sources. Otherwise, remote devices might continue to receive MoH from the local router flash, depending on the configured user/network hold audio sources.

Note that, once the branch SRST/gateway router is configured to provide multicast MoH, the router will continue to multicast the MoH stream even when not in fallback mode.

It is also possible to configure the fallback mode to use Cisco Unified Communications Manager Express (Unified CME) in SRST mode, referred to as Enhanced SRST (E-SRST). Fallback mode behavior is still the same, but the configuration commands are slightly different. SRST commands are entered under the Cisco IOS **call-manager-fallback** construct, while the commands for E-SRST mode are entered under **telephony-service**.

There are four methods of providing multicast MoH via SRST:

- SRST multicast MoH from branch router flash
- SRST multicast MoH from a live feed
- E-SRST mode with multicast MoH from branch router flash
- E-SRST mode with multicast MoH from a live feed

For more details on configuration of Cisco Unified SRST and E-SRST, refer to the following documentation:

- *Cisco Unified SRST System Administrator Guide*, available at [http://www.cisco.com/en/US/products/sw/voicesw/ps2169/products\\_installation\\_and\\_configuration\\_guides\\_list.html](http://www.cisco.com/en/US/products/sw/voicesw/ps2169/products_installation_and_configuration_guides_list.html)
- *Cisco Unified Communications Manager Express System Administrator Guide*, available at [http://www.cisco.com/en/US/products/sw/voicesw/ps4625/products\\_installation\\_and\\_configuration\\_guides\\_list.html](http://www.cisco.com/en/US/products/sw/voicesw/ps4625/products_installation_and_configuration_guides_list.html)

- For more information on using Cisco Unified SRST as a multicast MoH resource, refer to the section on *Integrating Cisco Unified Communications Manager and Cisco Unified SRST to Use Cisco Unified SRST as a Multicast MoH Resource* in the latest version of the *Cisco Unified SCCP and SIP SRST System Administrator Guide*, available at

[http://www.cisco.com/en/US/products/sw/voicesw/ps2169/products\\_installation\\_and\\_configuration\\_guides\\_list.html](http://www.cisco.com/en/US/products/sw/voicesw/ps2169/products_installation_and_configuration_guides_list.html)

## Distributed Multisite Deployments

Multisite IP telephony deployments with distributed call processing typically contain WAN or MAN connections between the sites. These lower-speed links usually cause bandwidth and throughput bottlenecks. To minimize bandwidth consumption on these links, Cisco recommends use of the G.729 codec for all MoH audio streams traversing them. Because the G.729 codec is optimized for voice and not music applications, you should use G.729 only across the WAN/MAN links, where the bandwidth savings far outweighs the lower quality afforded by G.729 for MoH transport.

Unlike with centralized multisite deployments, in situations where G.711 might be required for MoH audio streams traveling across a WAN, MoH audio streams cannot be forced to G.711 in a distributed multisite deployment. Even when MoH servers are placed in a separate Unified CM region and the G.711 codec is configured between this region and the intercluster or SIP trunk's region, the codec of the original voice call is maintained when a call between the two clusters is placed on hold by either phone. Because these intercluster calls are typically encoded using G.729 for bandwidth savings, a MoH stream from either cluster will also be encoded using G.729.

Another option is to provision multicast MoH for intercluster calls across an intercluster trunk (ICT) or SIP trunk. This allows endpoints in one Unified CM cluster to hear multicast MoH streamed from another Unified CM cluster, while making more efficient use of intercluster bandwidth. A properly designed IP Multicast environment is required to take advantage of this feature. For more information on IP Multicast, refer to the documentation available at

[http://www.cisco.com/en/US/products/ps6552/products\\_ios\\_technology\\_home.html](http://www.cisco.com/en/US/products/ps6552/products_ios_technology_home.html)

Proper multicast address management is another important design consideration in the distributed intercluster environment. All MoH audio source multicast addresses must be unique across all Unified CM clusters in the deployment to prevent possible overlap of streaming resources throughout the distributed network.

## Clustering Over the WAN

As its name suggests, clustering-over-the-WAN deployments also contain the same type of lower-speed WAN links as other multisite deployments and therefore are subject to the same requirements for G.729 codec, multicast transport mechanism, and solid QoS for MoH traffic traversing these links.

In addition, you should deploy MoH server resources at each side of the WAN in this type of configuration. In the event of a WAN failure, devices on each side of the WAN will be able to continue to receive MoH audio streams from their locally deployed MoH server. Furthermore, proper MoH redundancy configuration is extremely important. The devices on each side of the WAN should point to an MRGL whose MRG has a priority list of MoH resources with at least one local resource as the highest priority. Additional MoH resources should be configured for this MRG in the event that the primary server becomes unavailable or is unable to process requests. At least one other MoH resource in the list should point to an MoH resource on the remote side of the WAN in the event that resources at the local side of the WAN are unavailable.