

# UNITED STATES MARINE CORPS

MARINE CORPS ENGINEER SCHOOL  
UTILITIES INSTRUCTION COMPANY  
PSC 20069  
CAMP LEJEUNE, NORTH CAROLINA 28542-0069

## MEP-831 GENERATOR CHARACTERISTICS, CAPABILITIES, COMPONENTS, OPERATIONS AND PMCS CLASS

### 1. MEP-831A CHARACTERISTICS AND CAPABILITIES.

a. The MEP 831A is a 3kW (3000 watt) generator producing 60Hz of electric power. The MEP 831A is skid mounted with fork lift provisions.

b. The MEP 831A weighs 304lbs dry, and 334lbs with a full fuel tank. The MEP 831A is 34.8" long, 27.8" wide, and 26.5" tall. The MEP 831A has six lifting handles and four tie down rings. The MEP 831A can be manually lifted, or moved by forklift.

c. The MEP 831 has a hinged enclosure that allows quick access for preventive and scheduled maintenance. The cooling system for the MEP 831A is a thermostatically cooled by two fans.

d. The MEP 831A has a single-cylinder, air cooled, direct injection, four stroke Yanmar diesel engine. The engine operates between 3000 to 3600 RPM (6.7 HP at operating speed). The maximum RPM rating is 3800 RPM. The diesel engine for a MEP 831A has an oil capacity of 1.2 quarts (1.1 liters), and is consumed at 0.04 ounce (1.18 ml) per hour at a rated load.

e. The MEP 831A is equipped with a four gallon fuel tank, allowing eight hours of continuous operation at a full load. The MEP 831A is designed to consume .5 gallons per hour at a rated load. When the MEP 831A is connected to an auxiliary fuel system, it will be continually replenished. The MEP 831A is designed to use either diesel fuel type 1 (DF1) or 2 (DF2), and turbine fuel JP-8.

f. The MEP 831A has 24VDC cranking system. The MEP 831A has a Permanent Magnet Alternator (PMA) with a frequency converter.

g. The output voltages are a 2-plug 120VAC convenience receptacle with Ground Fault Circuit Interrupter (GFCI), single phase, 2 wire, 120VAC, or single phase, 3 wire, 120/240VAC. The current output for the MEP 831A is 31 amps max for 120VAC, and 16 amps max for 120/240VAC.

**PHYSICAL DESCRIPTION**

<b>Generator Set:</b>	
Manufacturer	Fermont
<b>Model</b>	<b>MEP-831A</b>
Fuel Tank Capacity (gal)	4
<b>Fuel Type</b>	<b>Diesel/JP-8</b>
Engine	
<b>Manufacturer</b>	<b>Yanmar</b>
Model	L70AE-D/DE
<b>Type</b>	<b>4 cycle, air cooled</b>
Number of Cylinders	1
<b>Speed (RPM)</b>	<b>3000 to 3600</b>
Dimensions	
<b>Length (in)</b>	<b>35</b>
Width (in)	28
<b>Height (in)</b>	<b>27</b>
Weight	
<b>Dry (lbs)</b>	<b>304</b>
Wet (lbs)	334
<b>Power Requirements</b>	
A/C Generator	
<b>Manufacturer</b>	<b>Dewey Electronics</b>
Type	Rotating field, synchronous
<b>Phase</b>	<b>1</b>
Current Ratings (amps)	60Hz
<b>120 volts, 2 wire</b>	<b>31a</b>
120/240 volts 3 wire	16a

2. **COMPONENTS OF THE TACTICAL QUIET GENERATOR (TQG).**

a. **Major Components.**

(1) Enclosure Assembly. The enclosure assembly (1, Figure 1-2), supports the control box assembly, cooling air system, and exhaust assembly components. It protects the engine, generator, and other internal components from damage. It incorporates a fire retardant acoustical insulation to reduce noise levels, and acts as a shield to reduce electromagnetic pulse effects on generator set components.

**WARNING**

Engine exhaust gas (Carbon Monoxide) is a deadly odorless, colorless, poisonous gas. Avoid breathing it.

(2) Enclosure Cooling and Ventilation System. Air intake openings and engine intake ducts at the rear of the enclosure assembly allow for the engine cooling using external air. Two thermostatically controlled fans (5, Figure 1-2) mounted in the enclosure assembly activate during high temperature conditions to drive hot exhaust air through openings in the enclosure.

(3) Skid Base. The welded skid base (17, Figure 1-2) provides the main structural support for the generator set. The engine/generator assembly is mounted to the skid base with vibration isolators which isolate engine generated vibration from the rest of the generator set. The generator set's plastic fuel tank is contained within the skid base, as is the 24VDC battery.

(a) The skid base contains four swing-out lift handles (7), two standard lifting handles (9), four tie-down rings (8), and two forklift openings (12).

(b) An oil drain plug (10) and fuel drain plug (11) protrude through openings on the skid base, on the right side of the generator set.

(c) A 24VDC slave receptacle (14) and load terminal connections (behind cover (16)) are mounted to the skid base at the rear of the generator set.

(4) Battery. A 24VDC battery, mounted in the skid base, provides cranking power for the engine as well as DC power for the control system. The battery's location in the skid base permits easy servicing. Openings in the enclosure assembly vent escaping battery gases to the atmosphere, preventing gas build-up inside the enclosure.

(5) Exhaust System. The generator set exhaust system (20) consists of a muffler and exhaust piping. Engine exhaust exits the generator set through an opening in the top of the enclosure assembly. Insulating material on the exhaust system components protects maintenance personnel against potential burn hazards and reduces heat rejection into the enclosure assembly.

(6) Control Box Assembly. The control box assembly is mounted to the enclosure assembly at the rear of the generator set. Instruments, controls, and indicators required to operate the generator set are located on the control box assembly. The control box assembly consists of a control panel (18, Figure 1-2), ground fault circuit interrupter, (13) (60Hz only).

(a) The control panel (18) portion of the box is hinged to allow access for testing and maintenance.

(b) The Control Panel Contains the Following Instruments and Switches:

1. HOURS Meter
2. FUEL LEVEL Gauge
3. VOLTAGE Meter
4. LOAD Meter
5. START/RUN/STOP Switch
6. EMERGENCY STOP Switch
7. AUX FUEL Switch
8. PREHEAT Switch
9. VOLTAGE ADJUST Switch
10. BATTLE SHORT Switch
11. Fault Indicator Module

a. The Fault Indicator Module Contains Lights that Indicate the Following Generator Set Conditions:

- (1) ENGINE HIGH TEMP
- (2) LOW OIL PRESSURE
- (3) NO FUEL
- (4) OVERVOLTAGE
- (5) OVERLOAD SHORT CIRCUIT

(6) BATTLE SHORT ON.

**WARNING**

Exposed fuel and fuel vapor can ignite or explode, resulting in possible serious injury or death.

(7) Output Terminals and Slave Receptacle. The output terminal board and ground terminal are located on the generator set skid base, just below the control box assembly. A hinged cover (16, Figure 1-2) allows access to the three load terminal and single ground terminal. An insulated wrench, used for connecting wires to terminals, is secured to the rear of the hinged cover. A filter mounted to the back of the load terminals prevents Electro-Magnetic Interference (EMI). The generator's 24VDC slave receptacle is mounted to the skid base, to the right of the output terminals.

(8) Engine/Generator Assembly. The engine/generator assembly (Figure 1-3) consists of a single-cylinder engine (14), permanent magnet generator (5), and associated electrical, fuel and oil components. The engine/generator assembly is mounted to the skid base (8) with vibration mounts (7) to prevent engine vibration from affecting the operation of the generator set components. A fuel drain plug (9) and oil drain plug (10) allow maintenance to drain engine fluids.

**WARNING**

**Electrocution Hazard**

Electrical high voltage cannot be seen but it can kill you, render you unconscious, or severely burn you. Failure to observe safety precautions may result in serious injury or death.

(9) Engine. The generator set is equipped with a single cylinder; air cooled, direct injection, four stroke cycle, diesel engine (14, Figure 1-3). The engine is designed to operate between 3000 and 3600 RPM. The engine has self-contained oil lubrication and fuel systems. The engine is equipped with an air filter (2), muffler (3), 24VDC starter motor (4), manifold heater (15), engine high coolant temperature switch (12), engine oil low pressure switch (12), and oil fill cap and gauge (11). A rope pulled recoil system (1) permits manual start of the engine without the battery. Engine cooling is provided by a flywheel fan, which forces air over the cylinder fins and engine components. The fan is completely guarded to prevent inadvertent contact during operation.

(10) Generator. The permanent magnetic generator (5, Figure 1-3) consist of four three phase isolated AC output windings. Voltage output is proportional to engine speed (approximately 190VAC at 3kW, 3450 RPM). The rotating portion of the generator is mounted directly to the engine, on the engine crankshaft extension, without a bearing.

(11) Power Inverter/Converter. The power inverter/converter (19, Figure 1-2) is located in the skid base, between the control box and generator. It provides the regulated 120VAC/240VAC, 2 wire, or 120/240VAC, 3 wire (single phase only) output.

(12) Fuel System. The generator set is equipped with a four-gallon fuel tank (1, Figure 1-4) which provides enough fuel to operate for eight hours at full load. The tank is mounted within the skid base. The tank's filler assembly consists of a filler neck (2), fuel strainer (3), and vented fill cap (4). The tank contains a fuel pick-up connection (5), fuel return connection (6), fuel drain connection (7), fuel-gap sending unit (8), and fuel level switch. An electric pump (10) feeds fuel from the tank (1), through a combination fuel filter/ water separator (11), on to the engine's fuel injection pump (12). An auxiliary fuel transfer pump (13) allows the generator to operate using an auxiliary fuel source.

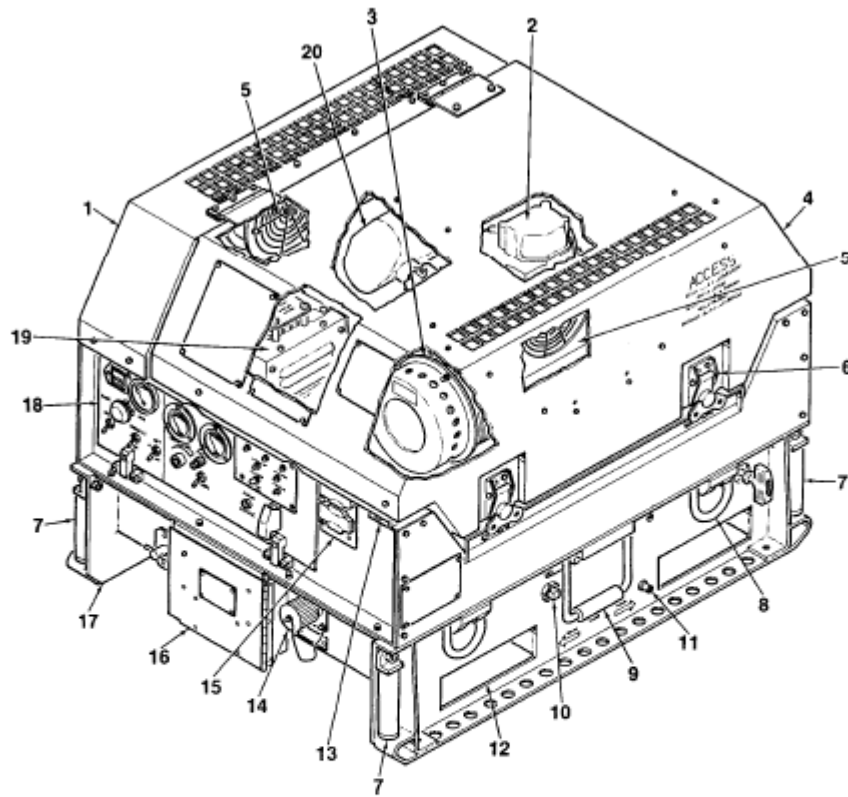

- |                       |  |  |
|-----------------------|--|--|
| 1. Enclosure Assembly | 8. Tie-Down Ring                                     | 14. Slave Receptacle                       |
| 2. Diesel Engine      | 9. Lifting Handle                                    | 15. Convenience Receptacle<br>(60 Hz only) |
| 3. Generator          | 10. Oil Drain Plug                                   | 16. Output/Load Terminal Cover             |
| 4. Enclosure Cover    | 11. Fuel Drain Plug                                  | 17. Skid Base                              |
| 5. Cooling Fan        | 12. Forklift Opening                                 | 18. Control Box Assembly                   |
| 6. Cover Latch        | 13. Ground Fault Circuit<br>Interrupter (60 Hz only) | 19. Power Inverter/Converter               |
| 7. Lifting Handle     |  | 20. Exhaust System                         |

*Figure 1-2. Location of Generator Set Components*

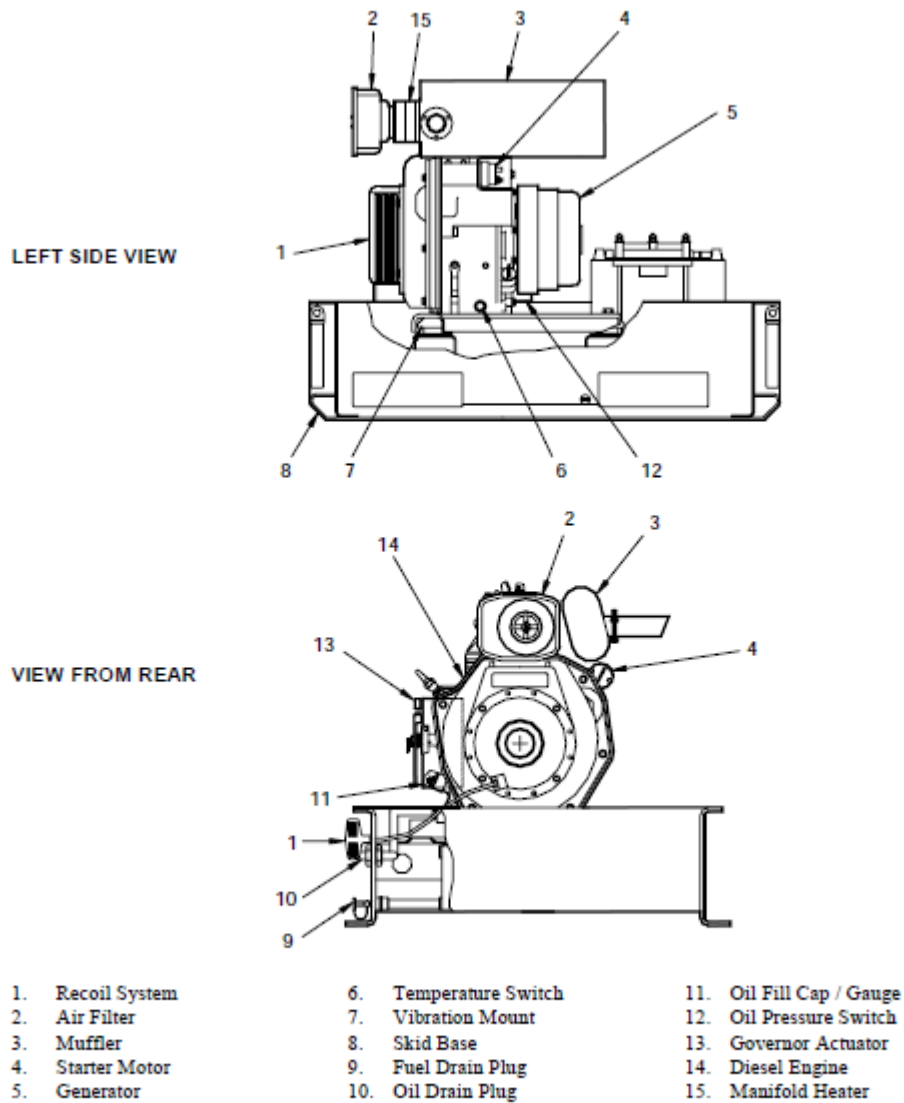

*Figure 1-3. Engine / Generator Assembly.*



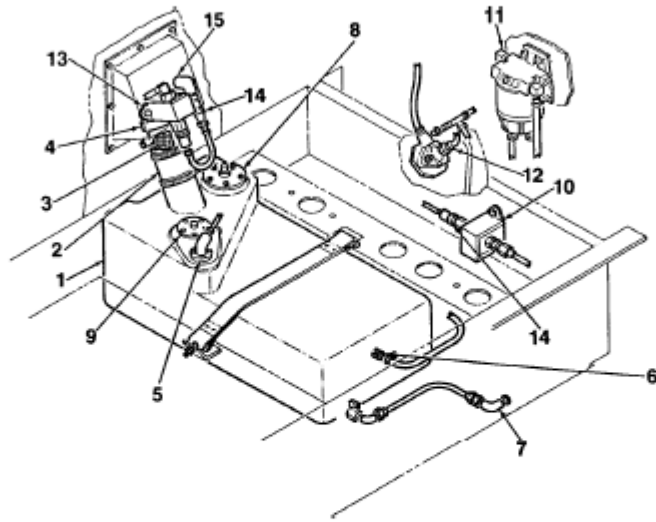

- |                       |                                   |                                     |
|-----------------------|-----------------------------------|-------------------------------------|
| 1. Fuel Tank          | 7. Drain Connection               | 12. Fuel Injection Pump             |
| 2. Filler Neck        | 8. Sending Unit                   | 13. Auxiliary Fuel Transfer Pump    |
| 3. Fuel Strainer      | 9. Fuel Level Switch              | 14. Fuel Strainer                   |
| 4. Fill Cap           | 10. Electric Fuel Pump            | 15. Auxiliary Fuel Input Connection |
| 5. Pick-Up Connection | 11. Fuel Filter / Water Separator |                                     |
| 6. Return Connection  |                                   |                                     |

*Figure 1-4. Generator Set Fuel System*

3. **DESCRIPTION AND USE OF OPERATORS CONTROLS AND INDICATORS.**

a. Prior to placing the generator set into operation, personnel must be familiar with the location and function of all switches, controls and indicators. Controls and indicators required for generator set operation are described below and identified on Figure 2-1.

(1) HOURS Meter. Indicates hours of generator set operation.

(2) FUEL LEVEL Meter. Indicates amount of fuel remaining in the generator set fuel tank.

(3) VOLTAGE Meter. Indicates generator set output voltage.

(4) LOAD Meter. Indicates generator load in kilowatts.

(5) DC CIRCUIT BREAKER. Trips to stop generator set operation in case of electrical surge in DC control system. Push to reset breaker.

(6) Fault Indication Module. Contains lights that indicate generator set operation conditions. Includes the following indicator lights:

(a) ENGINE HIGH TEMP fault (red)

(b) LOW OIL PRESSURE fault (red)

(c) NO FUEL fault (red)

(d) OVERVOLTAGE fault (red)

(e) OVERLOAD SHORT CIRCUIT fault (red)

(f) BATTLE SHORT ON fault (yellow)

(7) Dual purpose FAULT RESET/PUSH TEST switch allows operator to test indicator lights before operation, and reset fault isolation module after fault has been remedied.

(8) BATTLE SHORT Switch. Two-position switch that allows generator set operation under certain fault conditions.

(9) CONVENIENCE RECEPTACLE. (60Hz only) Single phase duplex receptacle which allows 120VAC appliance or tool connection.

(10) GROUND FAULT CIRCUIT INTERRUPTER (GFCI). (60Hz only) Provides automatic circuit interruption and circuit protection for the convenience receptacle.

(11) SLAVE RECEPTACLE. Allows for 24VDC auxiliary power connection for starting generator set.

(12) GND Terminal. Generator set ground terminal.

(13) L1, L2, N Terminals. Generator set alternating current (L1, L2) and neutral (N) terminals.

(14) CIRCUIT INTERRUPTER Switch. Two position switch that applies generator voltage to the output terminal board.

(a) CLOSED position signals AC circuit interrupter, to close, applying voltage to the terminal board.

(b) OPEN position opens AC circuit interrupter, terminating current to the load.

(15) CIRCUIT INTERRUPTER Indicator. Lights when CIRCUIT INTERRUPTER switch is in the CLOSED position, indicating load is being applied to the terminal board.

(16) VOLTAGE ADJUST Rheostat. Allows operator to adjust generator set output voltage.

(17) START/RUN/STOP Switch. Three-position switch that controls generator set operation.

(18) START position activates engine starter. Spring loaded. Must be held in position.

(a) RUN position cuts electrical power to the starter. Energizes all circuits required for normal operation.

(b) OFF position opens the circuit to the engine fuel transfer pump and governor control, stopping fuel flow to the engine and shutting down the generator set.

(19) PREHEAT Switch. Two-position switch that controls the engine preheat system.

(a) ON position sends a signal to engine preheat contactor to energize the engine air heater. Used during cold weather operation.

(b) OFF position de-energizes the engine air heater, halting engine preheat operations.

(20) AUX FUEL Switch. Two-position switch that allows the generator set to operate using an auxiliary fuel source.

(a) ON position allows a three-position fuel level switch to regulate auxiliary fuel flow into the fuel tank.

(b) OFF position de-energizes auxiliary fuel circuit, preventing the auxiliary fuel pump from operating.

(21) EMERGENCY STOP Switch. A push-button switch that opens the AC circuit interrupter and disconnects power to the governor control, which causes the generator set to shut down.

(22) Engine Start Handle (Pull-Start). Allows for manual start of the generator set engine. Activates engine's recoil starter assembly.

(23) FUEL DRAIN PLUG. Allows personnel to drain generator set fuel tank. It is connected to a fuel drain line.

(24) ENGINE OIL DRAIN PLUG. Allows personnel to drain engine oil sump. It is connected to an oil drain line.

(25) TEMPERATURE Switch. Monitors temperature inside the generator set enclosure. Activates ventilation fan when temperature reaches 85°F. (29°C)

(26) FUEL LEVEL Switch. Three-position switch that monitors fuel level in the generator set fuel tank. Controls auxiliary fuel transfer relay when the AUX FUEL switch is in the ON position.

(27) FUEL LEVEL SENDER. Sends generator set fuel tank level data to FUEL LEVEL meter.

(28) LUBRICATING OIL PRESSURE Switch. Monitors engine oil pressure. If oil pressure drops below 15 PSI, the switch closes the circuit to energize the fault lockout relay and shuts down the engine. The LOW OIL PRESSURE indicator on the fault indicator module will light.

(29) GOVERNOR CONTROL. Control Engine's mechanical governor to adjust engine speed.

(30) ENGINE TEMPERATURE Switch. Monitors engine temperature. If engine temperature rises above 265°F the switch closes the circuit and shuts down the engine. The ENGINE HIGH TEMP indicator on fault indicator module will light.

(31) ENGINE OIL FILL CAP and GAUGE. Allows for engine oil servicing. Gauge in cap measure crankcase oil level.

(32) FUEL FILL CAP. Allows for generator set fuel servicing using a fill tank or fuel nozzle. Includes a mesh fuel strainer.

(33) AUXILIARY FUEL CAP. Allows for connection of an auxiliary fuel hose.

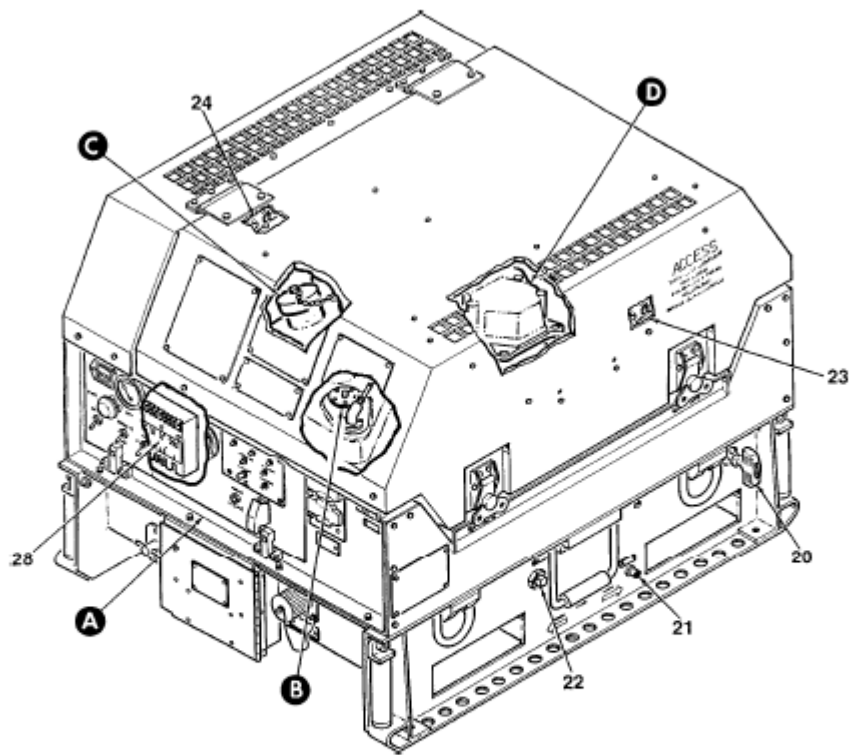

*Figure 2-1. Generator Set Controls and Indicators  
(Sheet 1 of 3)*

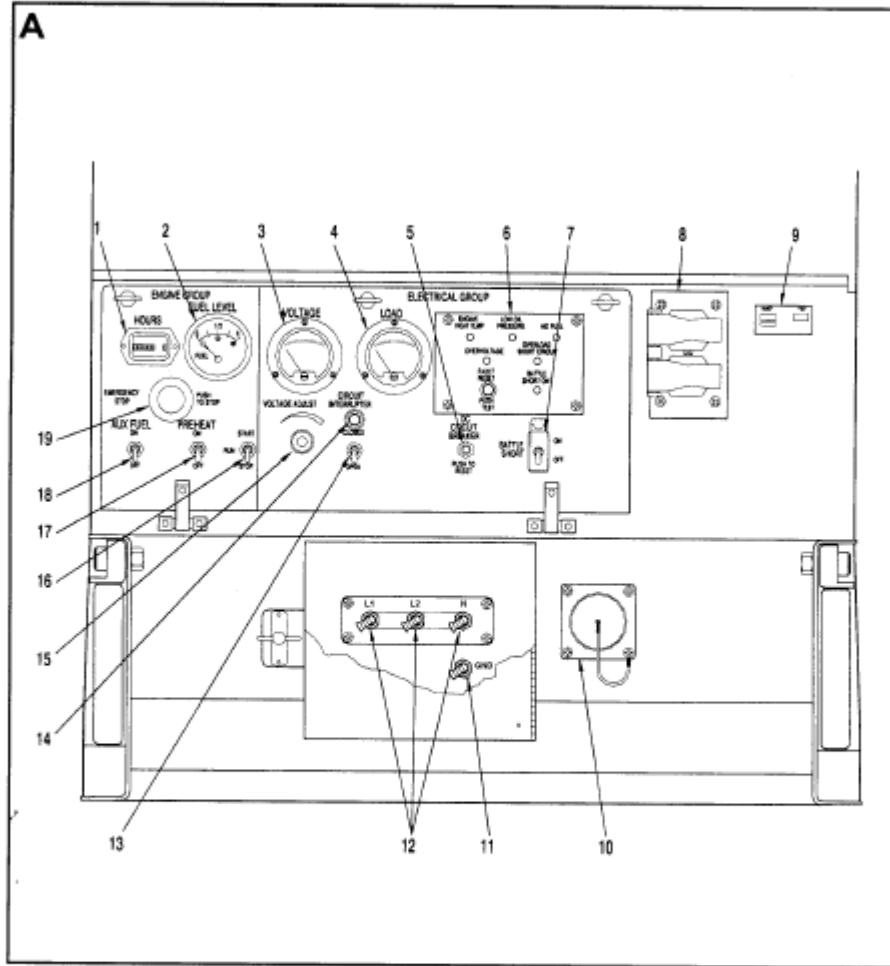
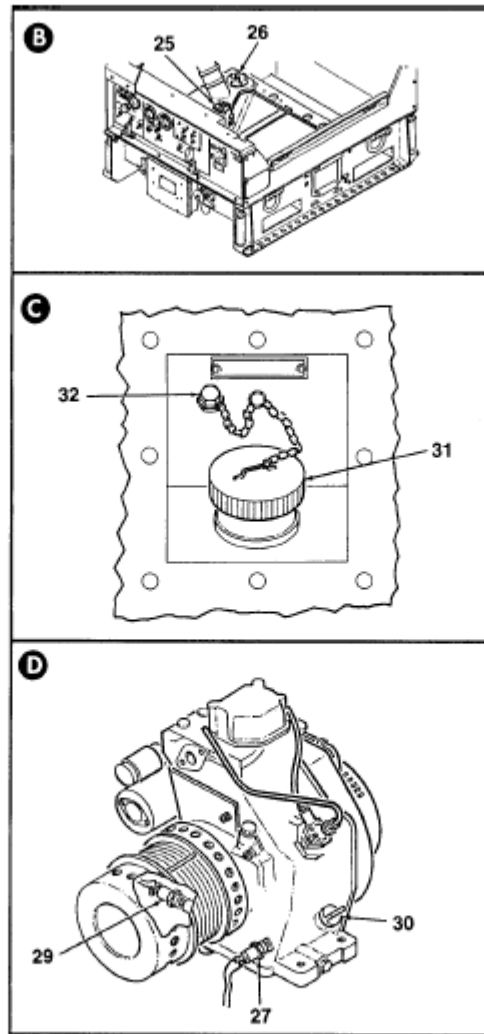

Figure 2-1. Generator Set Controls and Indicators  
(Sheet 2 of 3)



*Figure 2-1. Generator Set Controls and Indicators  
(Sheet 3 of 3)*



#### 4. GROUNDING.

a. Grounding of generators to earth is essential to place the generator at earth potential, preventing hazards to operators and draining static charges or stray current harmlessly to earth. The generator neutral output terminal (LO) is intentionally bonded to the generator grounding terminal on its frame or chassis which is then connected to earth. No current flows in the protective ground conductor unless there is a fault.

b. NEUTRAL IS NOT A GROUND! It carries current when the generator is supplying a load.

c. Generators are grounded to an Earth Ground System (EGS) consisting of one or more rods connected in parallel. The EGS resistance must be 10 ohms or less. The generator is connected to the EGS using the shortest practical length of #6AWG copper wire or larger. Ideally the conductor would be insulated, and five feet or less in length to the nearest EGS.

d. Never attempt to start a generator set if it is not properly grounded. Failure to observe this warning could result in serious injury or death by electrocution.

e. Connect Ground and Cable as Follows: (Refer to Table 2-2 on page 18.)

(1) Open Load terminal cover. Insert cable (1, Figure 2-2) through slot on generator set GND load terminal (2). Tighten terminal nut using wrench.

(2) Connect coupling (3) to ground rod (4) and screw driving stud (5) into coupling. Make sure that driving stud seats on ground rod.

(3) Drive ground rod (4) into ground until coupling (3) is just above the ground surface.

(4) Remove driving stud (5) and install another section of ground rod (4). Install another coupling (3) and driving stud.

(5) Drive ground rod (4) down until new coupling (3) is just above the ground surface.

(6) Repeat steps 4 and 5 until ground rod has been driven 8 feet or deeper, providing an effective ground. Connect clamp (6) and ground cable (1) to ground rod (4). Tighten clamp and screw securely to prevent movement.

(7) Ground rod must be installed within five feet or less from the generator.

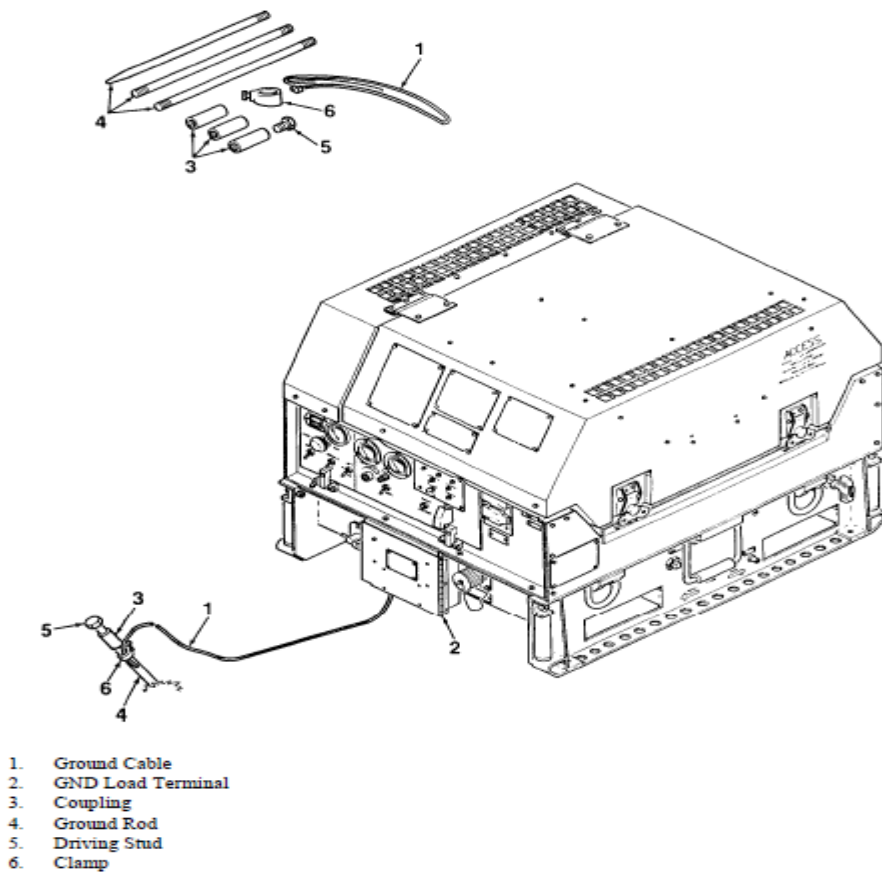

*Figure 2-2. Ground Rod and Cable Installation*

5. **MEP-831A GENERATOR SET OPERATIONS.**

a. **Before Operations PMCS.** A before operations check is exactly what it sounds like, certain checks that are performed before a piece of equipment is operated. This is also known as a "360°," since 360° is a complete circle. As the operator you will do a complete inspection of the equipment, visually and manually inspecting the piece of gear.

(1) Before operating any electrical equipment, ensure that the equipment is properly grounded with 10 ohms or less.

**!WARNING!**

Electrocution Hazard

Electrical high voltage cannot be seen but it can kill you, render you unconscious, or severely burned. Failure to observe safety precautions may result in serious injury or death.

(2) Inspect the housing, air ducts, exhaust grills, door fasteners and hinges for obstructions, serviceability and proper operation.

**!WARNING!**

Exposed fuel and fuel vapor can ignite or explode, resulting in possible serious injury or death.

(3) Ensure the acoustical material is free of damage or not missing.

(4) Inspect the skid bases to ensure that they are not corroded or cracked.

(5) Inspect the fill neck strainer for damage. Inspect vented fuel cap and auxiliary fuel connection for obvious damage or leakage.

(6) Ensure the identification plates are secured and are in place.

(7) Inspect the control box to ensure all switches, meters, indicators and terminals are operational.

(8) Check convenience receptacle for signs of electrical short and corrosion.

(9) Ensure NATO slave receptacle has no damage or shows any signs of electrical shock or corrosion.

(10) Ensure the output panel door locking latch operates properly, also check the load and ground terminals to ensure they are securely attached.

(11) Check exhaust system for cracks, holes, or dents.

(12) Inspect muffler for damage.

(13) Ensure the engine fuel system components are free from damage or leaks.

(14) Inspect and drain fuel filter/water separator.

(15) Inspect areas around the oil filter and oil drain hose for leaks. Remove oil fill cap and check oil level.

(16) Ensure air filter is not clogged.

b. **Starting Procedures.**

(1) Push in DC CIRCUIT BREAKER.

(2) Place START/RUN/STOP switch in the start position. (switch is spring loaded and must be held in place) Release switch to RUN position once the engine starts.

(3) Adjust voltage as required by using the VOLTAGE ADJUST rheostat.

(4) Place the AC CIRCUIT INTERRUPTER switch in the CLOSED position.

c. **During Operations PMCS.**

(1) Monitor the voltage and load output levels.

(2) Monitor fuel level.

(3) Look, listen and smell for anything unusual coming from the generator set.

d. **Shutdown Procedures.**

(1) Place the AC CIRCUIT INTERRUPTER switch in the OPEN position. Allow the generator 3-5 minutes to cool down the engine.

(2) Place the START/RUN/STOP switch in the STOP position.

(3) Pull out the DC CIRCUIT BREAKER.

<p style="text-align: center;"><b>NOTE</b> <b>GENERATOR MUST BE SHUT DOWN EVERY 8 HOURS TO SERVICE OIL AND FUEL WATER SEPERATOR. (SEE TABLE 2-1 ITEM 16 &amp; 17)</b></p>
---

e. **After Operations PMCS.**

(1) Inspect the housing, air ducts, exhaust grills, door fasteners and hinges for obstructions, serviceability and proper operation.

(2) Ensure the acoustical material is free of damage or not missing.

(3) Inspect the skid bases to ensure they are not corroded or cracked.

(4) Inspect the fill neck strainer for damage. Inspect vented fuel cap and auxiliary fuel connection for obvious damage or leakage.

(5) Ensure the identification plates are secured and are in place.

(6) Inspect the control box to ensure all switches, meters, indicators and terminals are operational.

(7) Check convenience receptacle for signs of electrical short and corrosion.

(8) Ensure NATO slave receptacle has no damage or shows any signs of electrical shock or corrosion.

(9) Ensure the output panel door locking latch operates properly also check the load and ground terminals for security of attachment.

(10) Check exhaust system for cracks, holes, or dents.

(11) Inspect muffler for damage.

(12) Ensure the engine fuel system components are free from damage or leaks.

(13) Inspect and drain fuel filter/ water separator.

(14) Inspect areas around the oil filter and oil drain hose for leaks. Remove oil fill cap and check oil level.

(15) Ensure air filter is not clogged.

**NOTE**

**The before during and after operations checks are listed on Table 2-1 on pages 22-28.**

Table 2-1. Operator Preventive Maintenance Checks and Services for MEP 831A / 832A

Item No.	Interval	Location: Item to Check/ Service	Procedure	Not Fully Mission Capable If:
1	Before	Overall generator set	<ul style="list-style-type: none"> <li>a. Inspect for cracks, dents, and corrosion in accordance with para. 3-5.</li> <li>b. Inspect for loose or missing hardware.</li> </ul>	Significant cracks in any generator set component.
2	Before	Generator set enclosure	<ul style="list-style-type: none"> <li>a. Inspect top lifting cover for security of attachment in accordance with para. 3-5.</li> <li>b. Inspect air intake and exhaust ducts for obstructions and blockages. Clear obstructions and check for damage.</li> </ul>	Cover is not secure. Latches do not lock, allowing cover to rattle excessively. Intake or exhaust are blocked, or damaged.
3	Before	Control box and output panel	<ul style="list-style-type: none"> <li>a. Inspect for secure attachment. Check that hinged panel is closed and locked.</li> <li>b. Inspect switches, meters, indicators, and terminals. Conduct fault lamp test by depressing FAULT RESET / PUSH TEST switch. Refer to para. 3-6.</li> <li>c. Inspect electrical wires for damage, corrosion, or electrical short. Check for bent, broken, or missing pins.</li> </ul>	Switch is not operable or meter is damaged. Fault indicator is defective or lamp does not light. Wires or connectors are damaged.

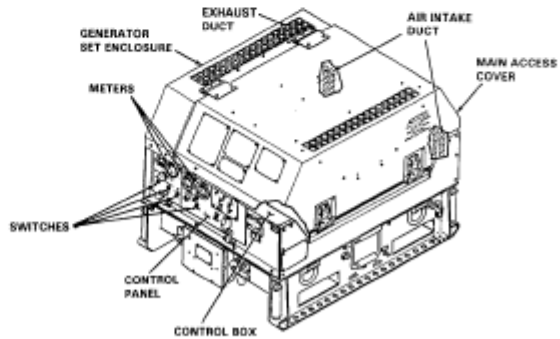

Table 2-1. Operator Preventive Maintenance Checks and Services for MEP 831A / 832A (continued)

Item No.	Interval	Location: Item to Check/ Service	Procedure	Not Fully Mission Capable If:
4	Before	Convenience receptacle (60Hz only)	Inspect receptacle for damage. Check for signs of electrical short or corrosion.	Receptacle damaged, shorted, or corroded.
5	Before	NATO slave receptacle	Inspect receptacle for damage. Check for signs of electrical short or corrosion.	Receptacle damaged, shorted, or corroded.
6	Before	Output panel	<p>a. Inspect output panel door for security. Check that locking latch operates properly.</p> <p style="text-align: center;"><b>WARNING:</b></p> <p>Ensure generator set is properly grounded prior to starting. Failure to properly ground can result in serious injury or death through electrocution.</p> <p>b. Check load and ground terminals for security of attachment. Inspect for signs of electrical short or corrosion.</p> <p>c. Check ground rod cable for proper installation. Check for correct connection.</p>	Terminals are loose, disconnected, shorted, damaged, or corroded. Set is not grounded properly.

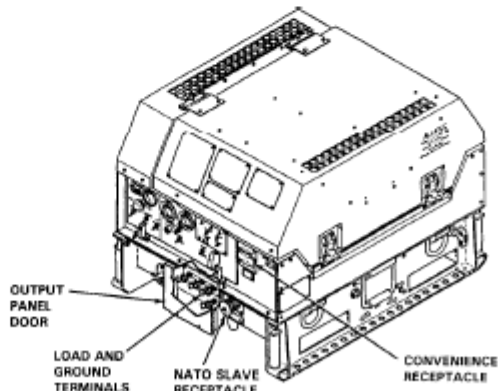



Table 2-1. Operator Preventive Maintenance Checks and Services for MEP 831A / 832A (continued)

Item No.	Interval	Location: Item to Check/ Service	Procedure	Not Fully Mission Capable If:
7	Before	Exhaust system	a. Inspect exhaust system for cracks, holes, or dents. Ensure secure attachment. b. Inspect muffler for obvious damage.	Exhaust system is damaged to the extent it will effect operation or safety of personnel.
8	Before	Fuel fill ports	a. Inspect fill neck strainer for damage. Remove obstructions or blockage. b. Inspect vented fuel cap and auxiliary fuel connection for obvious damage or leakage. Check that caps are securely attached.	Strainer is damaged. Fuel cap is damaged to the point where fuel leakage is likely.
9	Before	Fuel tank and hoses	Inspect generator set and engine fuel system components for damage or leaks in accordance with para. 3-7.	Fuel leaks of any kind are present. Fuel line is cut or damaged.
10	Before	Fuel filter / water separator	Inspect and drain filter / separator in accordance with para. 3-8.	Water and fuel are mixed. Separator is damaged or leaking.

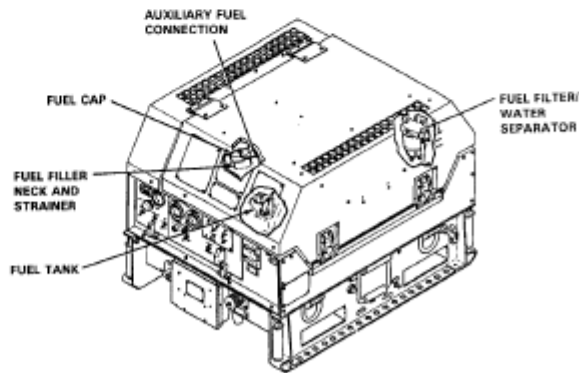

Table 2-1. Operator Preventive Maintenance Checks and Services for MEP 831A / 832A (continued)

Item No.	Interval	Location: Item to Check/Service	Procedure	Not Fully Mission Capable If:
11	Before	Skid base	a. Inspect oil and fuel drain ports for damage. Ensure drain plugs are securely attached. b. Inspect lifting handles and tie down rings for damage. Check security of attachment. c. Inspect engine vibration mounts for cracks, wear, or deterioration.	Drain ports are damaged to the extent they will leak. Lifting handles do not operate or are loose. Vibration mounts are damaged or worn.
12	Before	Engine oil	a. Open enclosure cover. Remove oil fill cap and check oil level. If servicing is required, refer to para. 3-1. b. Inspect areas around oil filter and oil drain hose for leaks.	Class III oil leaks are present. Refer to leakage class definitions (para. 2-5).
13	During	VOLTAGE and LOAD meters (control panel)	Monitor output levels during generator set operation. Adjust output as required using VOLTAGE ADJUST rheostat.	Adjustments cannot be made.
14	Before	Engine air filter	a. Inspect air filter for clogging in accordance with para. 3-9.	Filter is clogged.

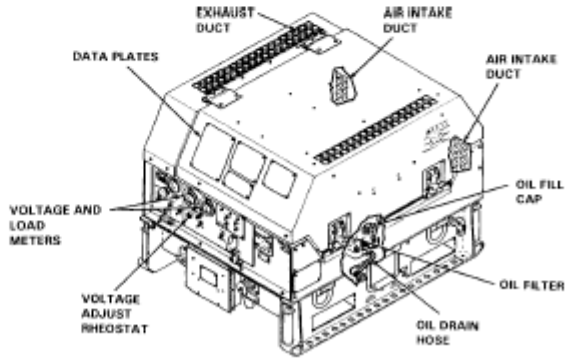

Table 2-1. Operator Preventive Maintenance Checks and Services for MEP 831A / 832A (continued)

Item No.	Interval	Location: Item to Check/ Service	Procedure	Not Fully Mission Capable If:
15	During	FUEL LEVEL meter (located on control panel)	<p>a. Monitor fuel level during generator set operation.</p> <p><b>WARNING:</b> Never service generator set while engine is running. Shut down unit before filling with fuel. Injury to personnel can occur if proper procedures are not followed.</p> <p>b. Replenish fuel as follows: Shut down generator set. Remove fuel fill cap and fill with proper fuel. Install fuel fill cap.</p>	Fuel level is empty or level meter is inoperable.
16	During (After 8 hours of continual use)	Engine oil	<p><b>WARNING:</b> Never service generator set while engine is running. Shut down unit before servicing oil. Injury to personnel can occur if proper procedures are not followed.</p> <p>a. Shut down generator set. Open enclosure cover.</p> <p>b. Remove engine oil fill cap and check oil level. Service as required in accordance with para. 3-1.</p>	Oil level is at or below minimum oil level mark on dipstick.

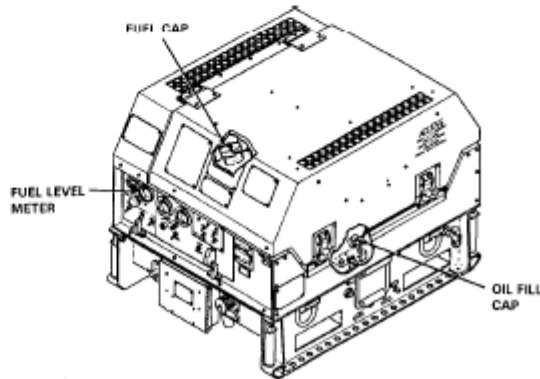
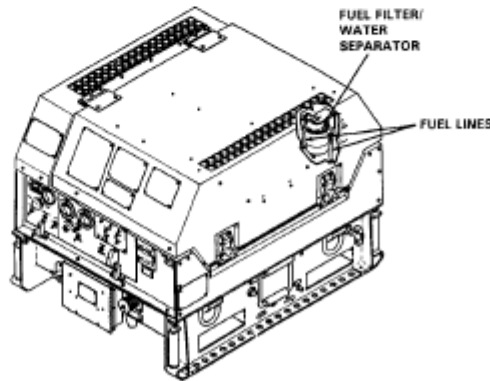

Table 2-1. Operator Preventive Maintenance Checks and Services for MEP 831A / 832A (continued)

Item No.	Interval	Location: Item to Check/ Service	Procedure	Not Fully Mission Capable If:
17	During (After 8 hours of continual use)	Fuel filter / water separator	<p><b>WARNING:</b> Never service generator set while engine is running. Shut down unit before draining filter separator. Injury to personnel can occur if proper procedures are not followed.</p> <p>a. Shut down generator set. Open enclosure cover.</p> <p>b. If water is present, drain water from fuel filter / water separator by turning valve.</p>	Water and fuel are mixed. Separator is damaged or leaking.
18	After	Fuel lines	Open enclosure cover. Inspect all fuel lines for cuts, tears, loose connections, or evidence of leakage.	Fuel leaks of any kind are present. Lines are cut, torn, loose, or damaged.
19	After	Overall generator set	<p>a. Inspect for cracks, dents, and corrosion in accordance with para. 3-5.</p> <p>b. Inspect for loose hardware.</p>	Significant cracks in enclosure.



*Table 2-1. Operator Preventive Maintenance Checks and Services for MEP 831A / 832A (continued)*

Item No.	Interval	Location: Item to Check/ Service	Procedure	Not Fully Mission Capable If:
20	After	Data plates	Check for legibility.	
21	After	Engine	a. Inspect engine fuel piping for damage, kinks, or evidence of leakage.  b. Inspect hoses for evidence of wear, cracking, or deterioration. Check connections for tightness.	Fuel leaks of any kind are present. Pipes or hoses are damaged.

6. **PREVENTATIVE MAINTENANCE CHECKS AND SERVICES (PMCS)**.

a. **Visual and Physical Inspection**. Before any type of maintenance can be performed, the first thing that needs to be done is a thorough visual and physical inspection of the equipment, along with documenting discrepancies on the NAVMC 10560 Technical Inspection form. As an incidental operator, you are not required to fill this form out, but you will be present at the time the inspection is conducted. There will be an inspection conducted when the equipment is issued and when it is returned. This inspection will include but not be limited to.

**WARNING**

Exposed fuel and fuel vapor can ignite or explode, resulting in possible serious injury or death.

**WARNING**

Engine exhaust gas (Carbon Monoxide) is a deadly odorless, colorless, poisonous gas. Avoid breathing it.

(1) Check For Different Types of Leaks:

(a) Class 1. Seepage of fluids (as indicated by wetness or discoloration) not enough to form drops.

(b) Class 2. Leakage of fluids, enough to form drops but not enough to cause drops to drip from item/equipment being checked or inspected.

(c) Class 3. Leakage of fluids, enough to form drops that fall from the item/equipment being checked or inspected.

(2) Damaged or broken parts.

(3) Frayed wires.

(4) Missing parts.

(5) Ensuring the equipment is grounded.

**NOTE**

Remember the Ditty: "There are no leaks! There are no Loose, Damaged, or Missing Components! There are no Burnt, Frayed, or Missing Wires!"

7. **FINDING REQUIRED MAINTENANCE.** (Refer to Table 2-2)

a. When the need for preventive maintenance has been identified, the operator must turn to the right place to find exactly what to do.

b. Each piece of equipment has specific requirements to keep it running in peak condition. Because most pieces of equipment are different, the operator should check the appropriate Technical Manual (TM) for instructions on when and how to conduct preventive maintenance.

c. Notice from the chart located on pages 10-11, procedures are listed on equipment needed to perform the PM. Under the "interval" column the operator can find what hour the maintenance will be performed at.

**WARNING**

Electrocution Hazard  
Electrical high voltage cannot be seen but it can kill you,  
render you unconscious,  
or severely burn you. Failure to observe safety precautions  
may result in serious injury or death.

8. **REMOVING PARTS DURING MAINTENANCE.**

a. **Removing Parts.** When attempting to remove parts while performing maintenance on any mobile electric power piece of equipment the following needs to be accomplished:

(1) Get the TM and go to the Alphabetical Index at the back of the TM.

(2) Look up the item or items that you will be working on.

(3) You Will Find the Removing Steps, for Example:

(a) Replacing the fuel filter goes to the Index and finds operators maintenance.

(b) Once you have found operators maintenance look at the list of repairs that you can do you will find the fuel filter and strainer assembly.

(c) There you are going to have a paragraph number.

Item No.	Interval	Location: Item to Check/ Service	Procedure	Not Fully Mission Capable If:
1	100 hours	Engine lubricating oil system	NOTE: First service occurs after 25 hours of engine operation. Follow 100 hours intervals thereafter.  Service engine lubricating oil and clean filter. Refer to Lubrication Instructions (Para. 4-1).	Engine oil has not been changed or filter has not been cleaned.
2	100 hours	Engine air filter	a. Open enclosure cover to gain access to engine air filter case. b. Remove air filter (Para. 3-9). c. Inspect air filter for dirt, clogging, or obstruction. Replace as required. d. Install air filter (Para. 3-9). e. Close enclosure cover and lock using latches.	Air filter is clogged, dirty, or damaged.
3	100 hours	Battery electrolyte level	Check battery electrolyte and gravity level (wet cell battery only). Service as required (Para. 4-44).	Battery electrolyte level is low.
4	300 hours	Fuel filter / water separator	Remove and replace filter / separator element (Para. 4-49).	Filter / separator element has not been replaced.
5	300 hours	Electrical system	Inspect electrical receptacles for damage, corrosion, or evidence of electrical short. Check for bent, broken, or missing pins. Clean deposits from receptacles.	Receptacles are damaged or burned.

Table 2-2



Item No.	Interval	Location: Item to Check/ Service	Procedure	Not Fully Mission Capable If:
6	500 hours	Engine air filter	Remove and replace engine air filter (Para. 3-9).	Engine air filter has not been replaced.
7	500 hours	Engine fuel injection pump	a. Inspect fuel injection pump for damage and evidence of leakage. Check area around pump sealing gasket for leaks.  b. Refer to TM 9-2815-257-24 for pump and gasket replacement.	Fuel injection pump is damaged or leaking. Pump sealing gasket leaking.
8	500 hours	Engine valves	Adjust engine valve clearance in accordance with TM 9-2815-257-24.	Engine valves are not properly adjusted, causing improper engine operation.
9	1000 hours	Engine fuel injector nozzle	Remove and replace fuel injector nozzle in accordance with TM 9-2815-257-24.	Fuel injector nozzle has not been replaced.

Table 2-2