

# ***Mercedes-Benz*** ***E-Class - Petrol*** ***WORKSHOP MANUAL***

**(Powered by 4, 6 & 8 cyl. Petrol Engines)**

## **W210 & W211 Series**

### **2000 - 2006**



**Covering:**

**Mercedes-Benz W210 & W211 Series**

**E200 - E240 - E280 - E320 - E350 - E430 - E500**

**Models fitted with 1.8, 2.0, 2.6, 2.8, 3.2, 3.5, 4.3, 5.0 Litre,**

**111 - 112 - 113 - 271 - 272, 4, 6 & 8 cyl. petrol**

**engines built between 2000 and 2006**

***OWNERS EDITION***

***Mercedes-Benz***  
***E-Class - Petrol***  
***WORKSHOP MANUAL***  
**W210 & W211 Series**  
**2000 - 2006**

***Covering:***

**Mercedes-Benz W210 & W211 Series**  
**E200 - E240 - E280 - E320 - E350 - E430 - E500**  
**Models fitted with 1.8, 2.0, 2.6, 2.8, 3.2, 3.5, 4.3, 5.0 Litre,**  
**111 - 112 - 113 - 271 - 272, 4, 6 & 8 cyl. petrol**  
**engines built between 2000 and 2006**



**BROOKLANDS BOOKS LTD.**  
**P.O. BOX 146, COBHAM,**  
**SURREY, KT11 1LG. UK**  
**sales@brooklands-books.com**

© Copyright 2012 by Brooklands Books Ltd. and PR Publications Limited

This book has been compiled from copyright text and illustrations supplied by PR Publications Limited and has been reissued with their kind permission.

Text and illustrations may not be reproduced, transmitted or copied by any means without the prior written permission of Brooklands Books Limited and PR Publications Limited.

Whilst every effort is made to ensure the accuracy of the particulars in this manual, neither the Publisher nor the Distributors nor the Dealer, by whom this manual is supplied shall under any circumstances be held liable for any inaccuracy or the consequences thereof.

Printed in England

ISBN 9781855209756

MBEP6E

[www.brooklands-books.com](http://www.brooklands-books.com)

Brooklands Books Ltd.  
PO Box 146, Cobham, Surrey KT11 1LG, England  
Tel: 01932 865051  
email: [sales@brooklands-books.com](mailto:sales@brooklands-books.com)

***Mercedes-Benz***  
***E-Class - Petrol***  
***WORKSHOP MANUAL***  
**W210 & W211 Series**  
**2000 - 2006**

***Covering:***

**Mercedes-Benz W210 & W211 Series**  
**E200 - E240 - E280 - E320 - E350 - E430 - E500**  
**Models fitted with 1.8, 2.0, 2.6, 2.8, 3.2, 3.5, 4.3, 5.0 Litre,**  
**111 - 112 - 113 - 271 - 272, 4, 6 & 8 cyl. petrol**  
**engines built between 2000 and 2006**



**BROOKLANDS BOOKS LTD.**  
**P.O. BOX 146, COBHAM,**  
**SURREY, KT11 1LG. UK**  
**sales@brooklands-books.com**

© Copyright 2012 by Brooklands Books Ltd. and PR Publications Limited

This book has been compiled from copyright text and illustrations supplied by PR Publications Limited and has been reissued with their kind permission.

Text and illustrations may not be reproduced, transmitted or copied by any means without the prior written permission of Brooklands Books Limited and PR Publications Limited.

Whilst every effort is made to ensure the accuracy of the particulars in this manual, neither the Publisher nor the Distributors nor the Dealer, by whom this manual is supplied shall under any circumstances be held liable for any inaccuracy or the consequences thereof.

Printed in England

ISBN 9781855209763

MBEP6EK

[www.brooklands-books.com](http://www.brooklands-books.com)

Brooklands Books Ltd.  
PO Box 146, Cobham, Surrey KT11 1LG, England  
Tel: 01932 865051  
email: [sales@brooklands-books.com](mailto:sales@brooklands-books.com)

## **CONTENTS**

<b><i>Introduction</i></b>	<b>5</b>
<b><i>Engines</i></b>	<b>12</b>
<b><i>Lubrication System</i></b>	<b>70</b>
<b><i>Cooling System</i></b>	<b>80</b>
<b><i>Clutch</i></b>	<b>95</b>
<b><i>Manual Transmission (Gearbox)</i></b>	<b>99</b>
<b><i>Propeller Shaft</i></b>	<b>102</b>
<b><i>Front Axle and Front Suspension</i></b>	<b>105</b>
<b><i>Rear Axle and Rear Suspension</i></b>	<b>116</b>
<b><i>Steering</i></b>	<b>125</b>
<b><i>Brakes</i></b>	<b>127</b>
<b><i>Servicing and Maintenance</i></b>	<b>147</b>
<b><i>Fault Finding Section</i></b>	<b>149</b>
<b><i>Wiring Diagram Index</i></b>	<b>155</b>
<b><i>Wiring Diagram Legend</i></b>	<b>188</b>

## ABOUT THIS BOOK

This Owners Edition - Workshop Manual covers the Mercedes-Benz E-Class W210 and W211 Series starting from Model Year 2000 to 2006, fitted with the four, six & eight cylinder petrol engines. It has been specially written for the practical owner who wants to maintain a vehicle in first-class condition and carry out the bulk of his or her own servicing and repairs. Comprehensive step-by-step instructions are provided for service and overhaul operations to guide the reader through what might otherwise be unfamiliar and complicated tasks. Numerous drawings are included to amplify the text.

With the aid of this manual, many aspects of service, overhaul and repair are within the scope of an owner with a reasonable degree of mechanical aptitude. Some operations however demand more skill. Other jobs require the use of special tools and in some cases testing facilities and techniques that are not generally available. Only you can judge whether a job is within your capabilities. We do however try to assist the reader to come to an informed decision. Whilst every effort has been made to ensure that the information provided is correct, it is obviously not possible to guarantee complete freedom from errors or omissions.

Information to be found in the driver's handbook is not necessarily duplicated here and it is not possible within this volume to cover every aspect to be found in the manufacturer's own workshop manual which is of much greater size and complexity. However, it should be consulted if more detailed information is needed.

Always remember that you are responsible for your own safety and that of others when working on a vehicle. Take particular care with safety-related systems like the brakes and steering, and seek professional advice if in any doubt. Never work under a vehicle unless it is properly supported (a single jack is not enough). Take care with power tools, also regard as potentially harmful fuel, lubricants, solvents and sealers which should always be and kept in labelled, sealed containers.

With care and common sense, the practical owner can make an excellent job of maintenance and overhaul. The benefits include money saved and the satisfaction of work well done. You will be adding to your knowledge, too: knowing more about the vehicle you own will help you to make logical decisions about what needs to be done, even if it does in some instances have to go into a professional repair shop. The Mercedes-Benz E-Class is a vehicle that will respond to careful regular servicing and is built to a standard that will ensure a long life if this is remembered.

## 0. INTRODUCTION

Our Owners Manuals are based on easy-to-follow step-by-step instructions and advice, which enables you to carry out many, jobs yourself. Moreover, now you have the means to avoid those frustrating delays and inconveniences which so often result from not knowing the right approach to carrying out repairs which are often of a comparatively simple nature.

Whilst special tools are required to carry out certain operations, we show you in this manual the essential design and construction of such equipment, whenever possible, to enable you in many cases to improvise or use alternative tools. Experience shows that it is advantageous to use only genuine parts since these give you the assurance of a first class job. You will find that many parts are identical in the various models covered, but our advice is to find out before purchasing new parts - **Always buy your spare parts from an officially appointed dealer.**

### 0.0 General Information

Four-cylinder, six-cylinder and eight-cylinder engines are covered in the manual:

**E200, 2.0 litre, four-cylinder:** Four-cylinder engine, 1996 c.c., with 16 valves with a performance of 163 B.H.P (120 kW). Engine type "111". As different engine types (different end numbers), we will list the model designation and the fitted engine type, as available: Model 210.035 = engine 111.942, model 210.048 = engine 111.957, model 210.048, model 210.235 = engine 111.942, model 210.248 = engine 111.957. The engine is not fitted to the W211 series.

**E200 Compressor, 1.8 litre, four-cylinder:** Four-cylinder engine, 1796 c.c., with 16 valves with a performance of 163 B.H.P (120 kW). Engine type "111" in Series W210 and "271" in Series W211. **W210 series:** Model 210.045 and 210.245 = engine 111.947. **W211 series:** Model 211.042 and 211.242 = engine 271.941, 111.947, model 211.043 = engine 271.943.

**E240, 2.6 litre, six-cylinder:** V6 engine with 18 valves, 2597 c.c. with a performance of 170 B.H.P (125 kW). Engine type "112". Fitted to series W210 and W211. **W210 series:** Model 210.061 and 210.261 = engine 112.911, model 210.062 and 210.262 = engine 112.914, **W211 series:** Model 211.061 and 211.261 = engine 112.913, model 211.080 and 211.280 = engine 112.917 (4 Matic).

**E280, 2.8 litre, six-cylinder:** V6 engine with 18 valves, 2799 c.c., with a performance of 204 B.H.P (165 kW). Engine type "112" (W210 series) or "272" (W211 series). Fitted to series W210 and W211. **W210 series:** model 210.063 and 210.263 = engine 112.921. W211 series: model 211.054 and 210.262 = engine 112.914, model 210.281 = engine 112.921 (4 Matic). **W211 series:** Model 211.054 and 211.254 = engine 272.943, model 211.092 and 211.292 = engine 272.944, (4 Matic), model 211.082 = engine 272.921 (4 Matic).

**E320, 3.2 litre, six-cylinder:** V6 engine with 18 valves, 3199 c.c., with a performance of 224 B.H.P (165 kW). Engine type "112". Fitted to series W210 and W211. **W210 series:** model 210.065 and 210.265 = engine 112.941, 210.082 and 210.282 = engine 112.941 (4 Matic). **W211 series:** model 211.065 and 211.265 = engine 112.949, model, Model 211.065 and 211.265 = engine 272.949, model 211.082 and 211.282 = engine 112.941 (4 Matic).

**E350, 3.5 litre, six-cylinder:** V6 engine with 24 valves, 3498 c.c., with a performance of 272 B.H.P (200 kW). Engine type "272". Fitted to series W211. Model 211.056 and 211.256 = engine 272.964, 211.087 and 211.287 = engine 272.962 (4 Matic).

**E430, 4.3 litre, eight-cylinder:** V8 engine with 24 valves, 4266 c.c., with a performance of 279 B.H.P (205 kW). Engine type "113". Fitted to series W210. Model 210.070 and 210.2706 = engine 113.940, 210.083 and 210.263 = engine 113.948 (4 Matic).

**E500, 5.0 litre, eight-cylinder:** V8 engine with 24 valves, 4966 c.c., with a performance of 306 B.H.P (225 kW). Engine type "113". Fitted to series W211. Model 211.070 and 211.270 = engine 113.947 and 113.967, 211.083 and 211.283 = engine 113.969 (4 Matic).



Two four-cylinder engines are fitted, available in two different capacities. In the category "Four-cylinder Engines" with 16 valves you will find two engines within the model years in question: All engines, however, belong to the engine type "111" or "271", depending on the model series, as described above.

The V6 six-cylinder engine with 18 valves is fitted to models E240, E280 and E320. Most engines belong to the series "112", but "272" engines are fitted to model series W211. A V6 engine with 24 valves is fitted to models E350 (engine type "272"). Finally there is the V8 engine in the model range. Engine type "113" is used for both capacities.

## **The advantages of a multi-valve technology**

One of the basic problems of a four stroke engine is the filling of the cylinders during the induction stroke with the necessary amount of the fuel/air mixture. The problem is made worse with increasing engine speed, as the opening period of the valves is shortened. Technicians refer to filling loss. To compensate the valve diameters are selected as large as possible so that more fuel/air mixture can enter, but the disadvantage is, of course, the larger diameter of the compression chamber.

This is the main reason for the introduction of the multi-valve technology. Four valve heads make up a larger opening area than two large valve heads and the size of the compression chamber can remain the same.

The advantages of the four valves can therefore be given as follows:

- Four valves enable larger opening diameters for inlet and exhaust gases. This helps the engine performance and the fuel consumption. This is one of the reasons that an engine with four valves per cylinder has a better consumption than a engine with two valves.
- Engines with four valves per cylinder have smaller valves and thereby less weight to be moved. A quicker response of the valve gear is therefore possible. One more advantage of this construction is that valve springs with a lower pressure are necessary to close the valves.
- Smaller valves are able to cool down quicker during the closing period.
- Engines with four valves per cylinder are also enable to obtain a higher compression ratio.
- The spark plugs can be centred in the compression chamber to provide the best possible igniting of the fuel/air mixture.

The vehicles covered in this manual are fitted with a six-speed manual transmission or an automatic transmission with five or seven speeds or a 4-Matic transmission.

The W210 and W211 series have a double wishbone front suspension with coil springs and telescopic shock absorbers and a stabiliser bar.

The so-called multi-link independent rear suspension comprises the rear axle carrier, provided with double-row angular ball bearings. The wheel carriers are guided by 5 specially located links, referred to as camber strut, pulling strut, pushing strut, track rod and spring links, the latter being the actual suspension arms. The hydraulic shock absorbers are fitted between the spring links and the body. A torsion bar is fitted to the spring links and the frame floor by means of a connecting link. The well-known level control system in other Mercedes Benz models is either fitted as standard or as an optional extra throughout the range.

Disc brakes on all four wheels, with dual-line brake system and brake servo is fitted. The handbrake acts on the rear wheels.

The rack and pinion steering with servo-assistance, introduced during the introduction of series W210 has been retained for series W211.

## **0.1 Vehicle Identification**

The type identification plate is located at the R.H. side on the upper face of the radiator frame and contains the vehicle type, chassis number, permissible maximum weight and the permissible axle load on front and rear axle. The paint code is located in the plate opposite.

The chassis number can also be found in the engine compartment bulkhead. The first six numbers refer to the vehicle type, the 7<sup>th</sup> number refers to the steering and the 8<sup>th</sup> number to the transmission. The following six numbers are the actual serial number.

The engine number is stamped into the cylinder block on the side of the starter motor, immediately below the intake tube.

The code numbers and letters must always be quoted when parts are ordered. Copy the numbers on a piece of paper and take it to your parts supplier. You will save yourself and your parts department delays and will prevent you from ordering the wrong parts.

## **0.2. General Servicing Notes**

The servicing and overhaul instructions in this Workshop Manual are laid out in an easy-to-follow step-by-step fashion and no difficulty should be encountered, if the text and diagrams are followed carefully and methodically. The "Technical Data" sections form an important part of the repair procedures and should always be referred to during work on the vehicle.

In order that we can include as much data as possible, you will find that we do not generally repeat in the text the values already given under the technical data headings. Again, to make the best use of the space available, we do not repeat at each operation the more obvious steps necessary - we feel it to be far more helpful to concentrate on the difficult or awkward procedures in greater detail. However, we summarise below a few of the more important procedures and draw your attention to various points of general interest that apply to all operations.

Always use the torque settings given in the various main sections of the manual. These are grouped together in separate sub-sections for convenient reference.

Bolts and nuts should be assembled in a clean and very lightly oiled condition and faces and threads should always be inspected to make sure that they are free from damage burrs or scoring. DO NOT degrease bolts or nuts.

All joint washers, gaskets, tabs and lock washers, split pins and "O" rings must be replaced on assembly. Seals will, in the majority of cases, also need to be replaced, if the shaft and seal have been separated. Always lubricate the lip of the seal before assembly and take care that the seal lip is facing the correct direction.

References to the left-hand and right-hand sides are always to be taken as if the observer is at the rear of the vehicle, facing forwards, unless otherwise stated.

Always make sure that the vehicle is adequately supported, and on firm ground, before commencing any work on the underside of the car. A small jack or a make shift prop can be highly dangerous and proper axle stands are an essential requirement for your own safety.

Dirt, grease and mineral oil will rapidly destroy the seals of the hydraulic system and even the smallest amounts must be prevented from entering the system or coming into contact with the components. Use clean brake fluid or one of the proprietary cleaners to wash the hydraulic system parts. An acceptable alternative cleaner is methylated spirit, but if this is used, it should not be allowed to remain in contact with the rubber parts for longer than necessary. It is also important that all traces of the fluid should be removed from the system before final assembly.

Always use genuine manufacturer's spares and replacements for the best results.

Since the manufacturer uses metric units when building the cars it is recommended that, these are used for all precise units. Inch conversions are given in most cases but these are not necessarily precise conversions, being rounded off for the unimportant values.

Removal and installation instructions, in this Workshop Manual, cover the steps to take away or put back the unit or part in question. Other instructions, usually headed "Servicing", will cover the dismantling and repair of the unit once it has been stripped from the vehicle it is pointed out that the major instructions cover a complete overhaul of all parts but, obviously, this will not always be necessary and should not be carried out needlessly.

There are a number of variations in unit parts on the range of vehicles covered in this Workshop Manual. We strongly recommend that you take care to identify the precise model, and the year of manufacture, before obtaining any spares or replacement parts.

Std.: To indicate sizes and limits of components as supplied by the manufacturer. Also to indicate the production tolerances of new unused parts.

O/S Parts supplied as Oversize or Undersize or recommended limits for such parts, to enable them to be used with worn or re-machined mating parts.

U/S O/S indicates a part that is larger than Std. size U/S may indicate a bore of a bushing or female part that is smaller than Std.

Max.: Where given against a clearance or dimension indicates the maximum allowable If in excess of the value given it is recommended that the appropriate part is fitted.

TIR: Indicates the Total Indicator Reading as shown by a dial indicator (dial gauge).

TDC: Top Dead Centre (No. 1 piston on firing stroke).

MP: Multi-Purpose grease.

### 0.3. Dimensions and Weights (typical)

Overall length – Saloon: .....	4820 mm
Overall length – Estate (“T”): .....	4850 mm
Overall width: .....	1820 mm
Overall height – Saloon – to 2002/from 2003: .....	1440/1450 mm
Overall height – Estate (“T”) – to 2002/from 2003: .....	1510/1495 mm
Wheelbase: .....	2885 mm
Front track – to 2001: .....	1544 mm
Front track – from 2002: .....	1575 mm
Front track – E320/E350: .....	1560 mm
Rear track: .....	1535 mm
Rear track – from 2002 (except below): .....	1570 mm
Rear track – E320/E350: .....	1555 mm
Kerb Weights (as available):	
- E200 – Saloon: .....	1465 kg (estate 1565 kg)
- E200 – Kompressor Saloon – from 2003: .....	1495 kg
- E200 – Kompressor Estate – from 2003: .....	1645 kg
- E240 – Saloon: .....	1515 kg (estate 1605 kg)
- E240 – Saloon – from 2002: .....	1495 kg (Estate 1645 kg)
- E280 – Saloon: .....	1535 kg
- E280 – Estate: .....	1625 kg
- E280 – Estate – 4matic: .....	1735 kg
- E320 – Saloon – before 2002: .....	1555 kg
- E320 – Saloon – from 2002: .....	1570 kg
- E320 – Estate: .....	1645 kg
- E320 – Estate – 4matic: .....	1735 kg (1710 kg from 2003)
- E430 – Saloon: .....	1605 kg
- E430 – Estate: .....	1708 kg
- E430 – Estate – 4matic: .....	1785 kg
- E500 – Saloon: .....	1650 kg

### 0.4 Capacities

Engines:

- Oil and filter change – 1.8/2.0 litre four-cylinder: .....	5.8 litres
- Oil and filter change – 2.6 litre six-cylinder: .....	5.5 litres
- Oil and filter change – 2.8/3.2 litre six-cylinder: .....	7.5 litres

- Oil and filter change – 4.3/5.0 litre eight-cylinder: ..... 9.5 litres
  - Oil and filter change – four-cylinder:..... 5.8 litres
  - Difference between Max/Min: ..... 2.0 litres
- Cooling System (with heater, approx.):
- Four-cylinder, manual gearbox: ..... 8.0 litres
  - Four-cylinder, automatic transmission: ..... 8.5 litres
  - Four-cylinder, with A/C system: ..... 9.0 litres
  - Six-cylinder: ..... 11.0 litres
  - Eight-cylinder: ..... 9.0 litres
- Transmissions: ..... See Section 3.0

## 0.5 Jacking up the Vehicle

To prevent damage to the underside of the vehicle, apply a jack or chassis stands only to the points specified below:

The front end of the vehicle should be lifted up by placing a jack underneath the transverse crossmember of the front suspension as shown in Fig. 0.1, taking care not to damage the undercover for the engine compartment. To lift the rear end of the vehicle, place the jack underneath the rear axle centre piece, as shown in Fig. 0.1 on the R.H. side. Make sure the jack is sufficient to take the weight of the vehicle. The vehicle can also be jacked up on one side. In this case place the jack underneath the hard rubber inserts near the wheels, as shown in Fig. 0.2 on one side of the vehicle. Never place a jack underneath the oil sump or the gearbox to lift the vehicle.

Chassis stands should only be placed on the L.H. and R.H. sides under the side of the body without damage to the paintwork. Use chassis stands of the construction shown in Fig. 0.3, should be used, but again make sure that they are strong enough to carry the weight of the vehicle. Make sure the vehicle cannot slip off the stands.

Before lifting the front of the vehicle engage first or reverse gear when a manual transmission is fitted or place the gear selector lever into the "P" (park) position when an automatic transmission is fitted. Use suitable chocks and secure the front wheels when the rear end of the vehicle is jacked up.

Always make sure that the ground on which the vehicle is to be jacked up is solid enough to carry the weight of the vehicle.

**Note:** It is always difficult to raise a vehicle first on one side and then on the other. Take care that the vehicle cannot tip-over when the first side is lifted. Ask a helper to support the vehicle from the other side. Never work underneath the vehicle without adequate support.

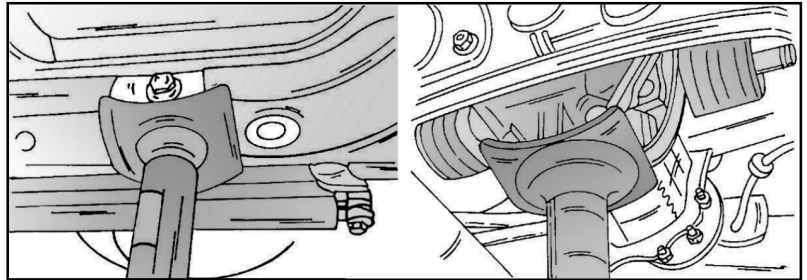

Fig. 0.1 – Jacking up the front end of the vehicle. The L.H. view shows where the jack is placed underneath the front crossmember. The R.H. view shows the jacking up of the rear of the vehicle. The jack is placed underneath the centre piece of the rear axle

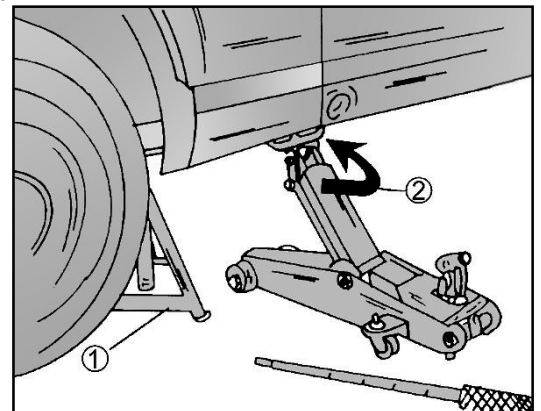

Fig. 0.2 – Jacking up one side of the vehicle. Place the jack (2) underneath the side of the body as shown. Chassis stands are placed at the position shown.

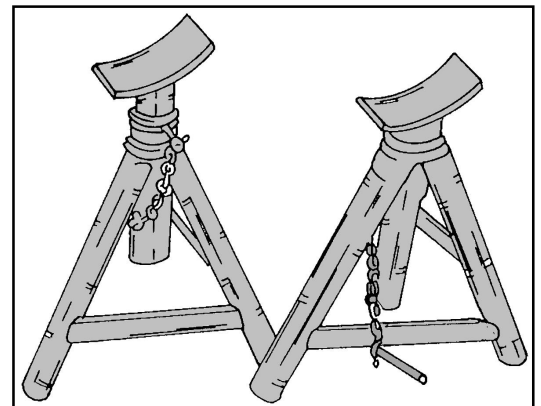
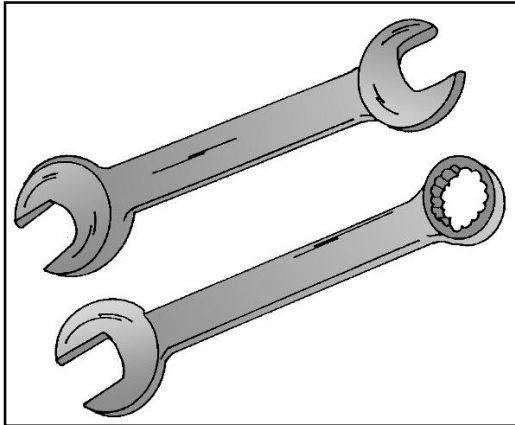

Fig. 0.3 – Three-legged chassis stands are the safest method to support the vehicle when work has to be carried out on the underside of

## 0.6. Recommended Tools

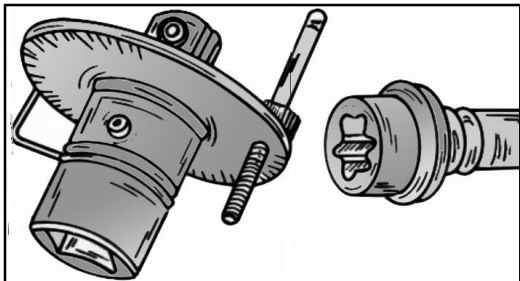

**Fig. 0.4** – A double open-ended spanner in the upper view and an open-ended/ring spanner in the lower view. Always make sure that the spanner size is suitable for the nut or bolt to be removed and tightened.

To carry out some of the operations described in the manual you will need some of the tools listed below:

As basic equipment in your tool box you will need a set of open-ended spanners (wrenches) to reach most of the nuts and bolts. A set of ring spanners is also of advantage. To keep the costs as low as possible we recommend a set of combined spanners, open-ended on one side and a ring spanner on the other side. Fig. 0.4 shows a view of the spanners in question. Sockets are also a useful addition to your tool set.

A set of cross-head screwdrivers, pliers and hammers or mallets may also be essential. You will find that many bolts now have a “Torx” head. In case you have never seen a “Torx” head bolt, refer to Fig. 0.5. A socket set with special t “Torx” head inserts is used to slacken and tighten these screws. The size of the bolts are specified by the letter “T” before the across-flat size.

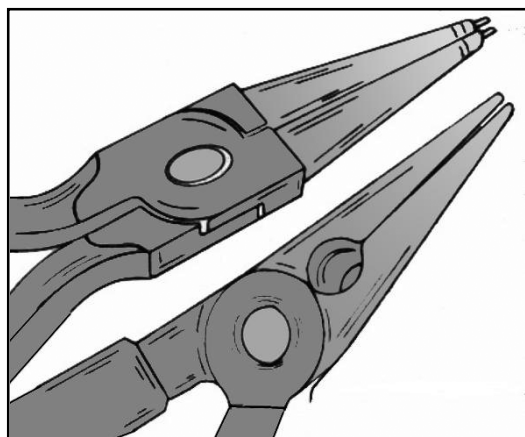

**Fig. 0.5** – A graduated disc is used to “angle-tighten” nuts and bolts. “Torx” head bolts are shown on the R.H. side.

Circlip pliers may also be needed for certain operations. Two types of circlip pliers are available, one type for external circlips, one type for internal circlips. The ends of the pliers can either be straight or angled. Fig. 0.6 shows a view of the circlip pliers. Apart from the circlip pliers you may also need the pliers shown in Fig. 0.7, i.e. side cutters, combination pliers and water pump pliers.

Every part of the vehicle is tightened to a certain torque value and you will therefore need a torque wrench, which can be adjusted to a certain torque setting. In this connection we will also mention a graduated disc, shown in Fig. 0.7, as many parts of the vehicle must be angle-tightened after having been tightened to a specific torque. As some of the angles are not straight forward (for example 30 or 60 degrees), you will either have to estimate the angle or use the disc.

Finally you may consider the tool equipment shown in Fig. 0.8, shown on the next page, which will be necessary from time to time, mainly if you intend to carry out most maintenance and repair jobs yourself.



**Fig. 0.6** – Circlip pliers are shown in the upper view. The type shown is suitable for outside circlips. The lower view shows a pair of pointed pliers.

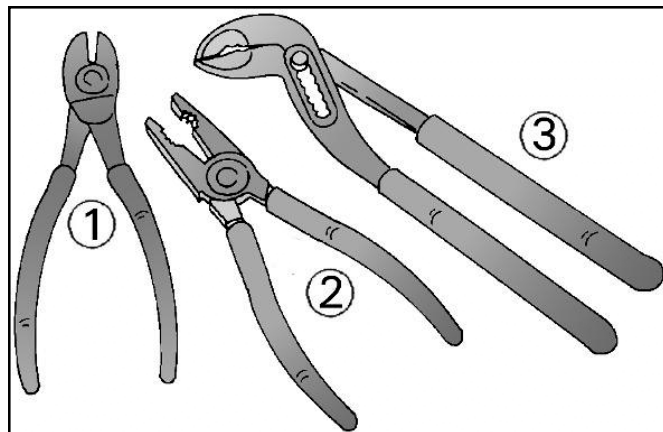

**Fig. 0.7** – Assortment of pliers suitable for many operations.

- 1 Side cutter
- 2 Combination pliers
- 3 Water pump pliers

## 0.7. Before you start

Before you carry out any operations on your vehicle it may be of advantage to read the following notes to prevent injuries and damage to the vehicle:

- Never carry out operations underneath the vehicle when the front or rear is only supported on the jack. Always place chassis stands in position (refer to next section). If no chassis stands are available and if the wheels are removed place one wheel on top of the other one and place them under the side of the vehicle where you are working. If the jack fails the vehicle will drop onto the two wheels, preventing injury.
- Never slacken or tighten the axle shaft nuts or wheel bolts when the vehicle is resting on chassis stands.
- Never open the cooling system when the engine is hot. Sometimes it may, however, be necessary. In this case place a thick rag around the cap and open it very slowly until all steam has been released.
- Never allow brake fluid or anti-freeze to come in contact with painted areas.
- Never inhale brake shoe or brake pad dust. If compressed air is available, blow off the dust whilst turning the head away. A mask should be worn for reasons of safety.
- Remove oil or grease patches from the floor before you or other people slip on it.
- Do not work on the vehicle wearing a shirt with long sleeves. Rings and watches should be removed before carrying out any work.
- If possible never work by yourself. If unavoidable ask a friend or a member of the family to have a quick look to check that's everything is OK.
- Never hurry up your work. Many wheel bolts have been left untightened to get the vehicle quickly back on the road.
- Never smoke near the vehicle or allow persons with a cigarette near you. A fire extinguisher should be handy, just in case.
- Never place a hand lamp directly onto the engine to obtain a better view. Even though that the metal cage will avoid direct heat it is far better if you attach such a lamp to the open engine bonnet.
- Never drain the engine oil when the engine is hot. Drained engine oil must be disposed of in accordance with local regulation.

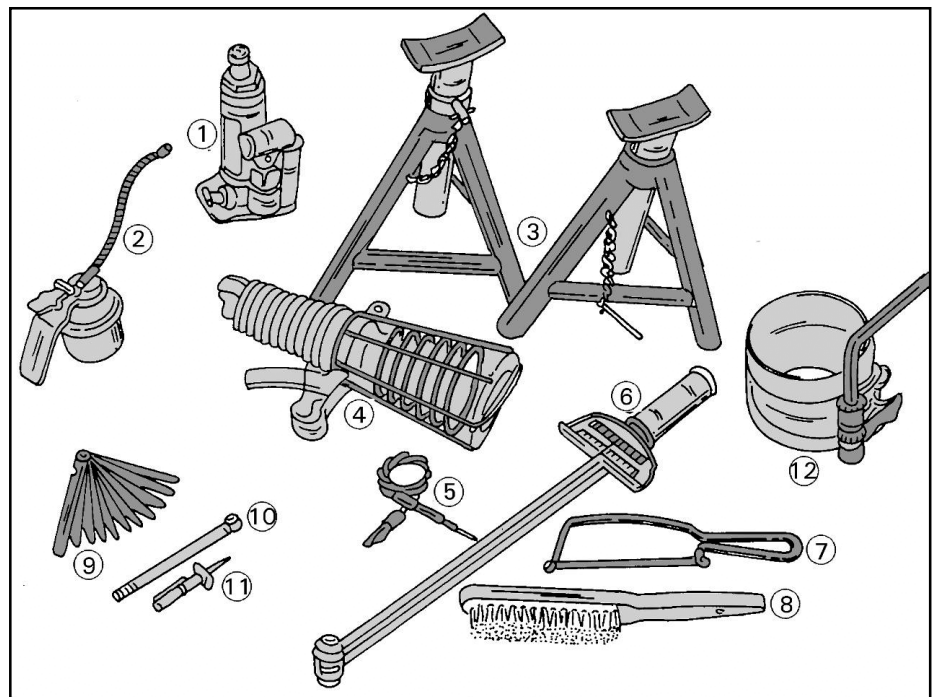

**Fig. 0.8 – Recommended tools to service and repair your vehicle.**

- |                        |                               |
|------------------------|-------------------------------|
| 1 Hydraulic jack       | 7 Small hand saw              |
| 2 Oil can              | 8 Wire brush                  |
| 3 Chassis stands       | 9 Feeler gauges               |
| 4 Electric hand lamp   | 10 Tyre pressure gauge        |
| 5 Test lamp (12 volts) | 11 Tyre profile depth checker |
| 6 Torque wrench        | 12 Piston ring clamp band     |

# 1. ENGINES

## 1.0. Main Features

Type: 4-stroke engine, with electronically controlled fuel injection and ignition system.

Fitted Engine (for details refer to Section 0.1):

- Mercedes E200: 111.942/957	
- Mercedes E200 Kompressor:	111.947 – W211 = 271.941/943
- Mercedes E240 – W210:	112.911/913/914
- Mercedes E240 – W211:	271.913/917
- Mercedes E280 – W210:	112.921 – 272.921/943/944
- Mercedes E280 – W211:	112.921 – 272.921/943/944
- Mercedes E320 – W210:	112.941
- Mercedes E320 – W211:	112.949/954
- Mercedes E350 – W211:	272.964/972
- Mercedes E430 – W210:	113.940/948
- Mercedes E500 – W211:	113.947/969

Number of cylinders: 4, 6 or 8  
Arrangement of cylinders: In line or V6 or V8

Capacity:

- 1.8 litres (Kompressor):	1796 c.c.
- 2.0 litres:	1996 c.c.
- 2.6 litres:	2597 c.c.
- 2.8 litres:	2799 c.c.
- 3.2 litres:	3199 c.c.
- 3.5 litres:	3498 c.c.
- 4.3 litres:	4266 c.c.
- 5.0 litres:	4966 c.c.

Max. Power (typical):

- 1.8 litres (Kompressor):	163 B.H.P. (120 kW) at 5500 rpm
- 2.0 litres:	163 B.H.P. (120 kW) at 5300 rpm
- 2.6 litres:	170 B.H.P. (125 kW) at 5500 rpm
- 2.6 litres from 2002:	177 B.H.P. (130 kW) at 5700 rpm
- 2.8 litres:	204 B.H.P. (150 kW) at 5700 rpm
- 3.2 litres:	224 B.H.P. (165 kW) at 5600 rpm
- 3.5 litres:	272 B.H.P. (200 kW) at 5500 rpm
- 4.3 litres:	279 B.H.P. (205 kW) at 5750 rpm
- 5.0 litres:	306 B.H.P. (225 kW) at 5600 rpm

Max. Torque:

- 1.8 litres (Kompressor):	24.5 kgm at 3000 rpm
- 2.0 litres:	23.4 kgm at 2500 rpm
- 2.6 litres:	24.5 kgm at 2500 rpm at 4500 rpm from 2002
- 2.8 litres:	27.5 kgm at 3000 rpm
- 3.2 litres:	31.5 kgm at 3050 rpm
- 3.5 litres:	35.7 kgm at 2400 rpm
- 4.3 litres:	40.8 kgm at 3000 rpm
- 5.0 litres:	46.9 kgm at 2700 rpm

#### Cylinder Bore:

- 1.8 litres:	82.00 mm
- 2.0 litres:	89.80 mm
- 2.6 litres:	89.90 mm
- 2.8/3.2/4.3 litres:	89.90 mm
- 3.5 litres:	92.90 mm
- 5.0 litres:	97.00 mm

#### Piston stroke:

- 1.8 litres:	85.00 mm
- 2.0 litres:	78.70 mm
- 2.6 litres:	68.20 mm
- 2.8 litres:	73.50 mm
- 3.2 litres:	84.00 mm
- 3.5 litres:	86.00 mm
- 4.3 litres/5.0 litres:	84.00 mm

#### Compression Ratio:

- 1.8/2.0 litres:	9.6 : 1
- 2.6 litres:	10.5 : 1
- 2.8 litres:	10.0 : 1
- 3.2/4.3 litres:	10.1 : 1
- 3.5 litres:	10.7 : 1
- 5.0 litres:	10.1 : 1

Catalytic converter: Yes

Lambda probe: Yes

Lead-free petrol: Yes

### **General Information**

The new engines fitted to the E-Class vehicles in the series W210 and W211 are different in many ways. The following information will tell you something about the new engines of type "111" (four-cylinder) and types "112" and "272" (six-cylinder V6) and the type "113" V8 engines. The information are given in general for all engines. V6 engines can have 18 or 24 valves, all four-cylinder engines have 16 valves.

- The 2.0 litre engine fitted to the end of production of series W210 is no longer fitted and has been replaced by the 1.8 litre engine with compressor.
- Vehicles with a manual gearbox have a dual-mass flywheel (some exceptions).
- The cylinder head, as already mentioned, has four valves per cylinder (either 16 valves in the case of a four-cylinder or 18 or 24 valves in the case of a six-cylinder). V8 engines have 24 valves. The cylinder head is made of light alloy metal. The valve seats, made of hardened steel, are pressed into the cylinder head. The valves are "gliding" in brass valve guides and are arranged as "overhead" valves, i.e. they are inserted vertically, valve head down, into the combustion chambers.
- Two camshafts are fitted. The shaft on the R.H. side, seen in the direction of drive, is responsible for the opening and closing of the exhaust valves, the L.H. shaft is the inlet valve camshaft. The bearings for the camshafts are not machined directly into the cylinder head.
- The valve tappets are inserted between camshafts and valve ends. The cams push against the ends of the tappets to operate the valves. The tappets are known as bucket tappets.
- The adjustment of the valves is no longer necessary on these engines. Hydraulic compensating elements are fitted which will ensure the correct valve clearance at all times. The function of the hydraulic valve clearance compensating elements is to eliminate valve clearance, i.e. the dimensional changes in the valve train (valve lash) due to heat expansion and wear are compensated by the elements. The rocker arm is in constant contact with the cam. The compensating elements cannot be repaired, but can be checked for correct functioning as described below. Fig. 1.1 shows sectional views of a valve with



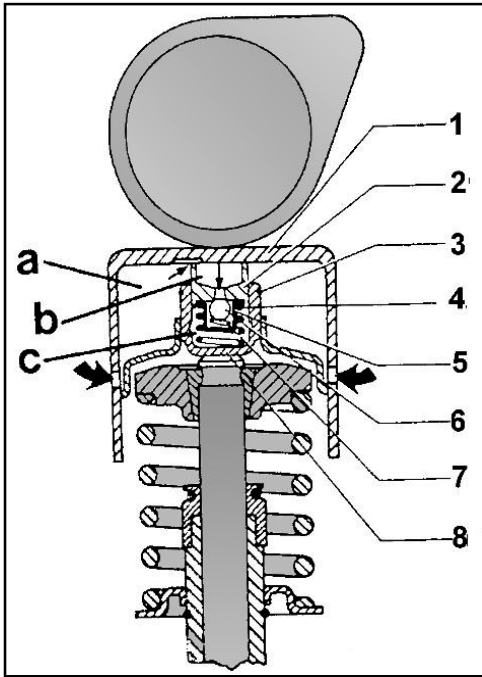

Fig. 1.1 – The operation of the hydraulic tappets. The oil enters via the bore (1) in the tappet into the valve tappet chamber (a), then into the smaller chamber (b) and then via the ball valve into the working chamber (c). The remaining parts are given below.

- |                   |                |
|-------------------|----------------|
| 1 Valve tappet    | 5 Ball guide   |
| 2 Thrust pin      | 6 Ball         |
| 3 Retaining ring  | 7 Gall guide   |
| 4 Pressure spring | 8 Guide sleeve |

clearance compensation. We will give a short description of the operation. All references refer to Fig. 1.1.

The hydraulic valve compensating element are fitted into the rocker levers and operate the valves directly via a ball socket:

- The thrust pin with oil supply chamber and the return bores and the ball valve (check valve). The ball valve separates the supply chamber from the work chamber.
- The guide sleeve with the work chamber (c), the thrust spring (4) and the closing cap.

When the engine is stopped and the tappet is held under load from the cam, the element can completely retract. The oil displaced from the work chamber (c) flows through an annular gap, i.e. the clearance between the guide sleeve and the thrust pin to the oil supply chamber (b).

When the cam lobe has moved past the valve tappet, the thrust pin will be without load. The thrust spring (4) forces the thrust pin upwards until the valve tappet rests against the cam.

The vacuum resulting from the upward movement of the thrust pin in the work chamber (c) opens the ball valve and the oil can flow from the supply chamber into the work chamber. The ball valve closes when the valve tappet presses against the cam and puts the thrust pin under load. The oil in the work chamber acts as a "hydraulic rigid connection" and opens the valve in question.

When the engine is running and depending on the engine speed and the cam position, the thrust pin is only pushed down slightly.

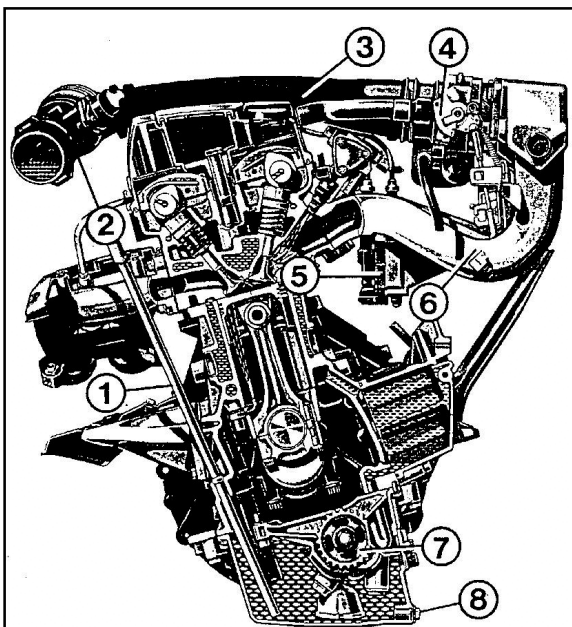

Fig. 1.2 – Sectional view of the engine with the location of some of the parts.

- |                        |                  |
|------------------------|------------------|
| 1 Oil dipstick         | 5 Ignition coil  |
| 2 HFM air mass meter   | 6 Air inlet tube |
| 3 Traverse intake tube | 7 Oil pump       |
| 4 Adjuster             | 8 Oil sump       |

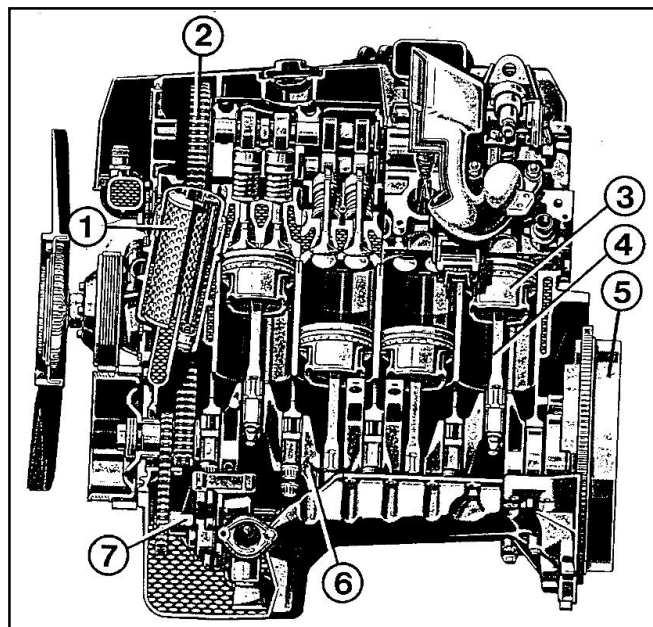

Fig. 1.3 – Longitudinal sectional view of the engine with the location of some of the parts.

- |                  |
|------------------|
| 1 Oil filter     |
| 2 Timing chain   |
| 3 Piston         |
| 4 Connecting rod |
| 5 Flywheel       |
| 6 Crankshaft     |
| 7 Oil pump       |

The oil contained in the oil supply chamber is sufficient to fill the work chamber under all operating conditions of the engine. Oil or leak oil which is not required, as well as air are able to escape via the annular gap between the washer and the rocker lever. The oil ejected from the work chamber flows via the annular gap between the guide sleeve and the thrust pin and the two return bores into the oil supply chamber.

- Some engines are fitted with a camshaft adjuster for the inlet camshaft. When the engine is running the camshaft will rotate by approx. 20° via a skew gear and an adjustment plunger.

### **Important Notes when working on the Engine**

Before any work is carried out in the engine compartment note the following points, mainly when the engine is running:

- The engine is fitted with an electronic controlled ignition system with a very high voltage. For this reason never touch the elements of the ignition system, as for example ignition coils, spark plug connectors or test sockets when the engine is running or when the engine is being started.
- Never touch any of the electronic elements with the ignition key in position "2" and the engine is cranked over by hand.
- Persons fitted with a pace maker should not carry out any operations on the electronic ignition system.

## **1.1. Engine – Removal and Installation**

### **1.1.0 REMOVAL OF THE FOUR-CYLINDER ENGINE**

The engine and gearbox should be removed as a single unit out of the engine compartment. The gearbox can then be removed from the engine. We would like to point out that the total weight of the power unit is approx. 200 kg and a suitable hoist or crane is required to lift out the assembly. The following instructions are given in general for all engines. The engine bonnet must be placed in vertical position or can be removed to prevent damage to the paintwork. In the case of engine type "111" proceed as follows. Details for the E200 (W211) with compressor (engine type "271") is referred to further on.

- Place suitable covers over both wings to prevent damage to the paintwork. Bring the engine bonnet into vertical position. To do this, lift the bonnet until the L.H. side engages with the lock. The safety hook of the bonnet is located in the centre of the radiator grille at the position shown in Fig. 1.4. Your Operators Manual will give you instructions how to lock the bonnet. Otherwise push the locking lever (1) in Fig. 1.5 in the direction of the arrow and lift the bonnet upwards, without allowing the lever to lock. Carry out the same operation on the R.H. side and bring the bonnet to the vertical position. Some of the operations are only referred to, i.e. "remove the radiator" will be described in section "Cooling System".
- Disconnect the positive battery lead from the battery and move the cable well away.

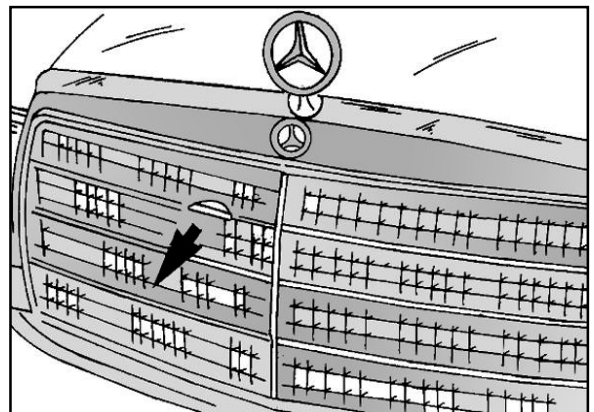

**Fig. 1.4 – The arrow points to the locking lever for the engine bonnet in the centre of the radiator grille.**

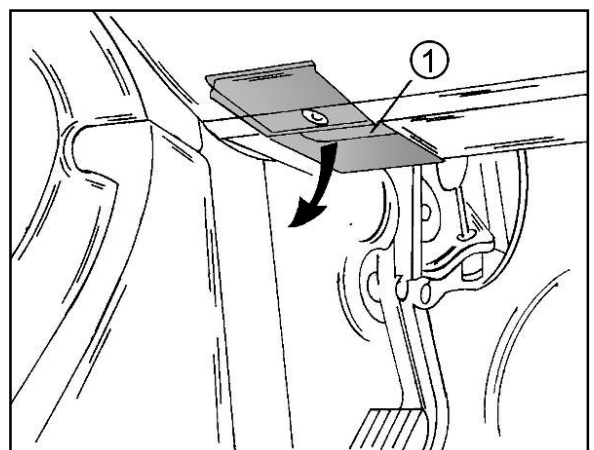

**Fig. 1.5 – The locking lever (1) must be moved as described to lock the engine bonnet in the vertical position.**

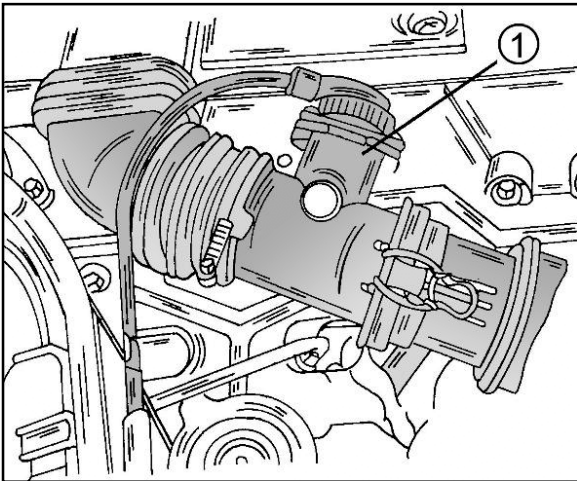

**Fig. 1.6 – The location of the “hot film” air mass meter (1) in the air intake hose.**

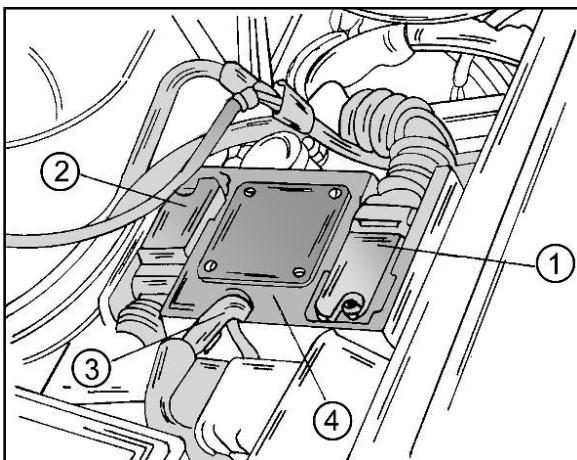

**Fig. 1.7 – The location of the engine control unit.**

- 1 Connection, vehicle side
- 2 Connection, engine side
- 3 Vacuum line to inlet manifold
- 4 Control unit

hose at the bottom of the reservoir and carefully drain the fluid. The steering system must be filled and bled of air during the installation of the engine.

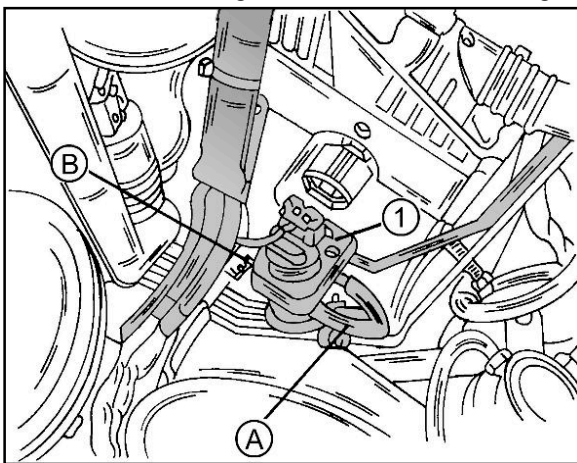

**Fig. 1.8 – The location of the changeover valve (1) for the charcoal canister. Disconnect the two hoses (A)**

- Open the expansion tank filler cap. The engine must be cold (not more than 90° C under any circumstances).
- Remove the undercover and unscrew the drain plug at the bottom of the radiator. Also remove the drain plug out of the side of the cylinder block to speed-up the draining of the coolant. The plug can be found below between two of the exhaust manifold tubes. The coolant contains anti-freeze. This must be collected or disposed of in suitable manner.
- Remove the viscous clutch for the cooling fan and remove the radiator.
- Remove the so-called hot film mass sensor. This item can be found at the position shown in Fig. 1.6 (only models with hot film air flow sensor).
- Remove the tube leading to the air cleaner.
- On vehicles with air conditioning remove the protective panel covering the condenser.
- Mark all connections of the engine cable harness in a suitable manner and disconnect them from the various units.
- Refer to Fig. 1.7 and disconnect the vacuum hose (3) from the electronic control unit (4).
- Refer to Fig. 1.8 and locate the vacuum changeover valve (1) and remove the two hoses (A) and (B). Hose (A) leads to the charcoal canister, hose (B) leads to the engine.
- Disconnect the throttle operating cable.
- Open the fuel filler cap to release the pressure in the fuel system.
- Empty the fluid container for the power-assisted steering. The workshop uses a hand-operated suction pump, illustrated in Fig. 1.9. Otherwise disconnect the

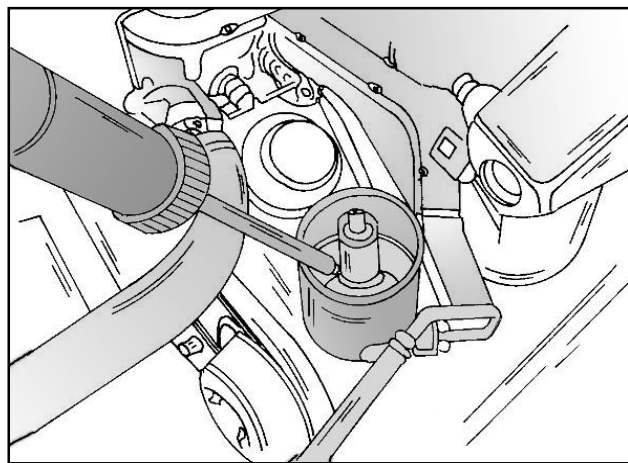

**Fig. 1.9 – The fluid from the steering fluid reservoir can be removed with a suitable hand pump after removing the reservoir cap**

- Refer to Fig. 1.10 to familiarise yourself with the connections of the fuel pipes. Disconnect the two fuel pipes (1) and (2) from their connections. Remove the vacuum hoses (3) and (4) from the inlet manifold.
- Disconnect the return pipe and the high pressure hose from the connections on the steering pump. If a tandem pump is fitted, the high pressure hose and an oil pipe must be disconnected. You will have to know of course which type of pump is fitted. The various connections are shown in Fig. 1.11. After connecting the various hoses the pressure chamber of the tandem pump must be bled of air.
- Disconnect the coolant hoses at the rear of the cylinder head and at the front of the water pump after slackening of the hose clamps.
- If an air conditioning system is fitted release the tension of the "Poly" drive belt and remove it. The A/C compressor must now be removed. Four bolts secure the compressor to the engine. Remove the compressor together with the connected pipe bundle and secure it to the bottom of the engine compartment with a piece of wire.

Jack up the front end of the vehicle and place chassis stands in position. The next operations are carried out from below.

- Remove the complete exhaust system.
- Remove the speedometer drive shaft from the rear gearbox cover (unscrew it). The location of the shaft can be seen in Fig. 1.12.
- Unscrew the propeller shaft flange at the gearbox. Slacken the nut securing the slide piece and the bolts securing the intermediate bearing. Push the propeller shaft back as far as possible. This requires that the heat shield on the floor panel is partly unscrewed (5 fastening points).
- Disconnect the hydraulic hose for the clutch operation by separating the hose from the fluid pipe. Plug the open ends of the pipe to prevent entry of dirt.
- Unscrew the earth cable from the gearbox.
- Disconnect the gearchange linkages from the side of the transmission after removal of the spring clips (see Fig. 1.13).
- If an automatic transmission is fitted, rotate the white plastic lock on the starter inhibitor switch and reversing light switch by 45° towards the right and withdraw the plug. Also disconnect the gearchange linkage and the kick-down switch from the transmission.
- Attach suitable ropes or chains to the engine lifting eyes and attach the ends to a hoist or crane. Operate the lifting equipment until the ropes/chains are just tight.

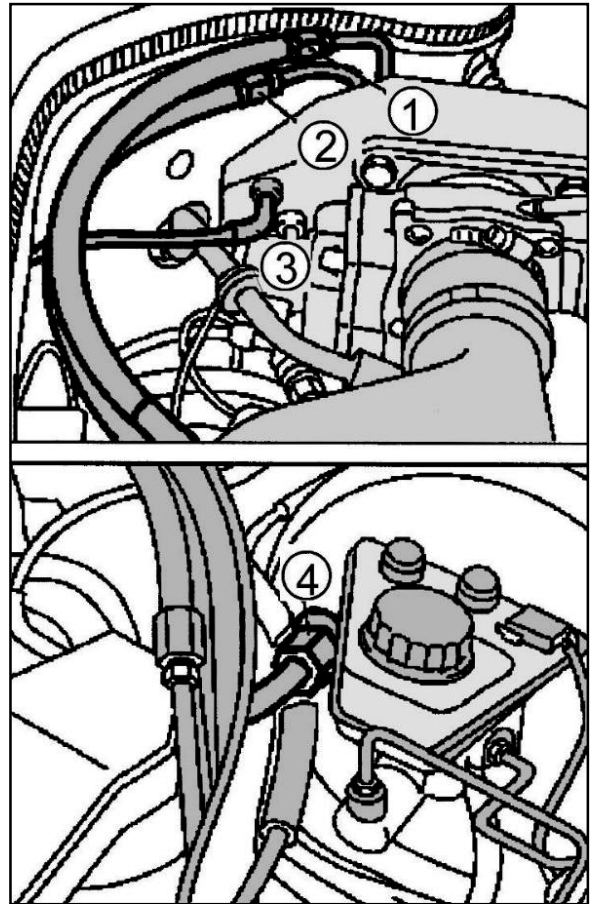

Fig. 1.10 – The two fuel hoses (1) and (2) must be disconnected from their connections. Vacuum hoses (3) and (4) are connected to the inlet manifold.

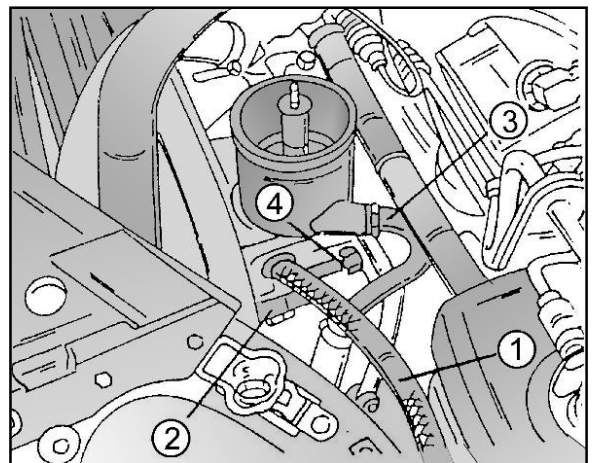

Fig. 1.11 – The hose connections on the steering pump and the tandem pump.

- 1 High pressure hose
- 2 Oil pipe
- 3 Return hose
- 4 High pressure hose