

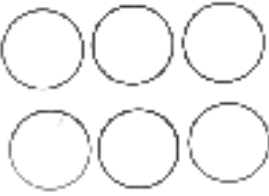



MERCUISER

Drive System

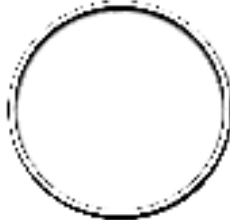
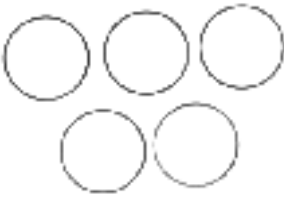

 <p>18-2292 AP# 2468 DRIVE GEAR SHIM KIT Replaces: 15-35980A-1 Contains (1) each .002, .003, .005, .006, .010, .025</p>	 <p>18-2293 AP# 2469 UPPER BEARING SHIM KIT Replaces: 15-36178A-1 Contains (1) each .002, .003, .015 (2) each .010</p>	 <p style="text-align: center;">SHIMS</p> <table border="1"> <thead> <tr> <th>Sierra #</th> <th>AP #</th> <th>Size</th> <th>O.E. #</th> </tr> </thead> <tbody> <tr><td>18-0206</td><td>—</td><td>.206</td><td>23-17615-14</td></tr> <tr><td>18-0210</td><td>—</td><td>.210</td><td>23-17615-16</td></tr> <tr><td>18-0212</td><td>—</td><td>.212</td><td>23-17615-17</td></tr> <tr><td>18-0214</td><td>—</td><td>.214</td><td>23-17615-18</td></tr> <tr><td>18-0218</td><td>—</td><td>.218</td><td>23-17615-20</td></tr> <tr><td>18-0220</td><td>—</td><td>.220</td><td>23-17615-21</td></tr> <tr><td>18-0222</td><td>—</td><td>.222</td><td>23-17615-22</td></tr> <tr><td>18-0224</td><td>—</td><td>.224</td><td>23-17615-23</td></tr> <tr><td>18-0226</td><td>—</td><td>.226</td><td>23-17615-24</td></tr> <tr><td>* 18-2282</td><td>—</td><td>Kit</td><td>15-32563A1</td></tr> <tr><td>* 18-2283</td><td>2471</td><td>Kit</td><td>15-45691A1</td></tr> <tr><td>* 18-2284</td><td>—</td><td>Kit</td><td>15-31535A1</td></tr> <tr><td>* 18-2285</td><td>2472</td><td>Kit</td><td>15-47397A1</td></tr> <tr><td>18-2296</td><td>2474</td><td>.055</td><td>15-71013</td></tr> </tbody> </table> <p>* 18-2282 (1) each .002, .003, .005, .010, .025 * 18-2283 (1) each .002, .003, .005, .010 * 18-2284 (1) each .002, .003, .005, .010, .020 * 18-2285 (1) each .002, .003, .005, .010, .020</p>	Sierra #	AP #	Size	O.E. #	18-0206	—	.206	23-17615-14	18-0210	—	.210	23-17615-16	18-0212	—	.212	23-17615-17	18-0214	—	.214	23-17615-18	18-0218	—	.218	23-17615-20	18-0220	—	.220	23-17615-21	18-0222	—	.222	23-17615-22	18-0224	—	.224	23-17615-23	18-0226	—	.226	23-17615-24	* 18-2282	—	Kit	15-32563A1	* 18-2283	2471	Kit	15-45691A1	* 18-2284	—	Kit	15-31535A1	* 18-2285	2472	Kit	15-47397A1	18-2296	2474	.055	15-71013
Sierra #	AP #	Size	O.E. #																																																											
18-0206	—	.206	23-17615-14																																																											
18-0210	—	.210	23-17615-16																																																											
18-0212	—	.212	23-17615-17																																																											
18-0214	—	.214	23-17615-18																																																											
18-0218	—	.218	23-17615-20																																																											
18-0220	—	.220	23-17615-21																																																											
18-0222	—	.222	23-17615-22																																																											
18-0224	—	.224	23-17615-23																																																											
18-0226	—	.226	23-17615-24																																																											
* 18-2282	—	Kit	15-32563A1																																																											
* 18-2283	2471	Kit	15-45691A1																																																											
* 18-2284	—	Kit	15-31535A1																																																											
* 18-2285	2472	Kit	15-47397A1																																																											
18-2296	2474	.055	15-71013																																																											
 <p>18-2294 AP# 2470 LOWER DRIVE SHAFT BEARING SHIM KIT Replaces: 15-42637A-1 Contains (1) each .002, .003, .005, .010, .020</p>	 <p>18-2295 AP# 2473 LOWER DRIVE SHAFT BEARING SHIM KIT Replaces: 15-57007A-1 Contains (1) each .002, .003, .005, .010, .020</p>																																																													

SHIM KIT APPLICATION

HP	Serial Number	Bearing to Top Cover Kit	Bearing Cup to Drive Shaft Housing	Drive Gear	Drive Gear Spacer	Drive Shaft Bearing to Gear Housing	Reverse Gear	Forward Gear Kit
120/140	2062141 thru 2791956	18-2282 ②	18-2293	18-2292	18-2296	18-2295	18-2284 ⑤	18-2285
120/140	2791957 thru 4893634	18-2283 ④	18-2293	18-2292	18-2296	18-2295	18-2284 ⑤	18-2285
120/140	4893635 thru 6225576	18-2283	18-2293	18-2292	18-2296	18-2295	—	18-2285
160	2065190 thru 2763441	18-2282 ②	18-2293	18-2292	18-2296	18-2295	18-2284 ⑤	18-2285
165	2763442 thru 4890459	18-2283 ④	18-2293	18-2292	18-2296	18-2295	18-2284 ⑤	18-2285
165	4890460 & UP	18-2283	18-2293	18-2292	18-2296	18-2295	—	18-2285
888	3106717 & UP	18-2283 ③	18-2293	18-2292	18-2296	18-2295	18-2284 ⑤	18-2285
898/228	4782330 thru 4898729	18-2283	18-2293	18-2292	18-2296	18-2295	18-2284 ⑤	18-2285
898/228	4898730 thru 6225576	18-2283	18-2293	18-2292	18-2296	18-2295	18-2297	18-2285
225-S	3856268 thru 4200499	18-2283	18-2293	18-2292	18-2296	18-2295	18-2284 ⑤	18-2285
233	4200500 & UP	18-2283	18-2293	18-2292	18-2296	18-2295	18-2284 ⑤	18-2285
250	4791300 thru 4898729	18-2283	18-2293	18-2292	18-2296	18-2295	18-2284 ⑤	18-2285
260	4898730 thru 6225576	18-2283	18-2293	18-2292	18-2296	18-2295	—	18-2285
470	4208730 thru 4893934	18-2283	18-2293	18-2292	18-2296	18-2295	18-2284 ⑤	18-2285
470	4893835 thru 6225576	18-2283	18-2293	18-2292	18-2296	18-2295	—	18-2285
485	4893835 & UP	18-2283	18-2293	18-2292	18-2296	18-2295	—	18-2285
R/MR/Alpha One	6225577 & UP (R)	18-2283	18-2293	18-2292	18-2296	18-2295	—	18-2285
R/MR/Alpha One	6225577 & UP (MR)	18-2283	18-2293	18-2292	18-2296	18-2294	①	18-2285
Alpha Gen II	D494569 thru F679999	18-2283 ①	18-2293	18-2292	18-2296	18-2294	①	18-2285
Alpha Gen II	F680000 & UP	18-2282	18-2293	18-2292	18-2296	18-2294	①	—

- ① For .206" Shim use Part Number 18-0206 ① For .220" Shim use Part Number 18-0220 ③ S/N #4433200 & UP Only
- ① For .210" Shim use Part Number 18-0210 ① For .222" Shim use Part Number 18-0222 ④ S/N #4530702 & UP Only
- ① For .212" Shim use Part Number 18-0212 ① For .224" Shim use Part Number 18-0224 ⑤ Kit
- ① For .214" Shim use Part Number 18-0214 ① For .226" Shim use Part Number 18-0226
- ① For .218" Shim use Part Number 18-0218 ② S/N #2187468 & Below use 18-2293



Complete Upper & Lower Units Lower Gear Housings

4 Complete Upper Units

Mercruiser Alpha I

Features...



- ★ Available in 4 gear ratios
 - 1.5:1, (1.47:1 when used on new lower units)
 - 1.65:1, (1.62:1)
 - 1.85:1, (1.81:1)
 - 1.98:1, (1.94:1)

Features...

- ★ Built with proven components, our gears have passed a grueling 300 hour endurance test under the most extreme conditions with flying colors.
- ★ Quality is our #1 goal. Rigorous quality checks are in place through every step of the manufacturing process.
- ★ Every unit goes through stringent quality control tests (pressure tested and vacuum tested).

Complete Lower Unit

Mercruiser Alpha I

Complete Upper Units			Complete Lower Units		
Sierra#	Replaces:	Ratio	Sierra#	Replaces:	Application
18-2450	1547-9412A20	1.5:1 / 1.47:1	18-2443	1623-8951A43	For: R/MR/ALPHA
18-2451	1547-9412A21	1.65:1 / 1.62:1	Lower Gear Housings		
18-2452	1547-9412A22	1.84:1 / 1.81:1			
18-2453	1547-9412A23	1.98:1 / 1.94:1	Sierra#	Replaces:	Application
 <p>18-2358 GEAR HOUSING SERVICE KIT Replaces: 43-803102T1 For: 20-22 Teeth: 1.47:1 Ratio</p>			18-2401	1623-8951A27	For: MR/ALPHA Style
			18-2402	1623-5356A4	For: R Style
 <p>18-2364 GEAR HOUSING SERVICE KIT Replaces: 43-803119T1 For: 24-24 Teeth: 11.62:1 Ratio</p>			 <p>18-2363 GEAR HOUSING SERVICE KIT Replaces: 43-803118T1 For: 20-24 Teeth: 1.94:1 & 2.40:1 Ratio</p>		





Upper Unit Gears

Features...

- ★ Manufactured to the strictest specifications.
- ★ Forward and reverse gears made from 8620 bearing quality steel. Pinion is made from 9310 bearing quality steel.
- ★ All gears are made from forged steel blanks.
- ★ Precision cutting processes are used to hold precise tolerances.
- ★ Heat treat specifications are batch certified.
- ★ Available in individual sets or in convenient complete repair kits.
- ★ Sierra offers all the right parts to do the job right.

 <p>18-2201 AP# 1267 UPPER UNIT GEAR SET Replaces: 43-18410A2, 43-18411A2 Includes: (1) 18-1142 Mercruiser #31-32573A1 (1.5:1 Ratio) (Drive Gear = 22 teeth Driven Gear = 20 teeth) For most V-8 Drives and Gen II (S/N K999999 & BELOW)</p> <table border="1"> <thead> <tr> <th>Stern Drive Model</th> <th>Beg. S/N</th> <th>End. S/N</th> <th>Stern Drive Model</th> <th>Beg. S/N</th> <th>End. S/N</th> </tr> </thead> <tbody> <tr> <td>225</td> <td>3856268</td> <td>4200499</td> <td>888</td> <td>3106717</td> <td>& UP</td> </tr> <tr> <td>260</td> <td>4898730</td> <td>6225576</td> <td>V8R/MR/AlphaOne</td> <td>6225577</td> <td>& UP</td> </tr> <tr> <td>898/228</td> <td>4782330</td> <td>6225576</td> <td></td> <td></td> <td></td> </tr> </tbody> </table>	Stern Drive Model	Beg. S/N	End. S/N	Stern Drive Model	Beg. S/N	End. S/N	225	3856268	4200499	888	3106717	& UP	260	4898730	6225576	V8R/MR/AlphaOne	6225577	& UP	898/228	4782330	6225576				 <p>18-2203 AP# 13063 UPPER UNIT GEAR SET Replaces: 43-45814A5 (1.65:1 Ratio) (Drive Gear = 24 teeth Driven Gear = 24 teeth) For: 6 Cyl. Inline S/N K999999 & BELOW</p>
Stern Drive Model	Beg. S/N	End. S/N	Stern Drive Model	Beg. S/N	End. S/N																				
225	3856268	4200499	888	3106717	& UP																				
260	4898730	6225576	V8R/MR/AlphaOne	6225577	& UP																				
898/228	4782330	6225576																							
 <p>18-6353 UPPER GEAR SET Replaces: 43-853643A2 1.81 Ratio Upper Gear Set, 17-19 Teeth For: Alpha I Gen II 1998-up/0L00040-up</p>	 <p>18-2204 AP# 13064 UPPER UNIT GEAR SET Replaces: 43-75325A3 (1.84:1 Ratio) (Drive Gear = 17 teeth Driven Gear = 19 teeth) For: V-6 and 470/485 (4 Cyl. etc.) and Gen II (S/N K999999 & BELOW)</p>	 <p>18-2205 AP# 13065 UPPER UNIT GEAR SET Replaces: 43-55778A3 (1.98:1 Ratio) (Drive Gear = 20 teeth Driven Gear = 24 teeth) For: 120/140 (S/N 2791957 & UP) and Gen II (S/N 999999 & BELOW)</p>																							

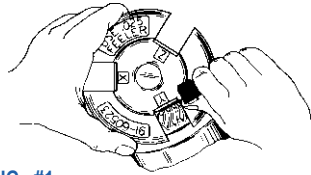

FIG. #1

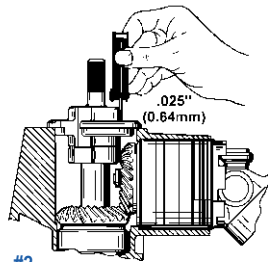

FIG. #2

FIGURES #1 - #2

Provides two separate views of the upper gear housing driven gear being properly shimmed using the Sierra installation tools.

FIGURES #3 - #4

Provides the same views of the drive gear being shimmed in the same application.

NOTE:

This installation **cannot** be performed correctly without the Sierra shim tool. Improper installation **will** result in gear failure. The .025 referenced in **FIG #2** & **FIG #4** is achieved when .026 will not fit the clearance but .025 will.

A service manual should always be consulted for step-by-step instructions. See Sierra Manual and Tool Catalog.

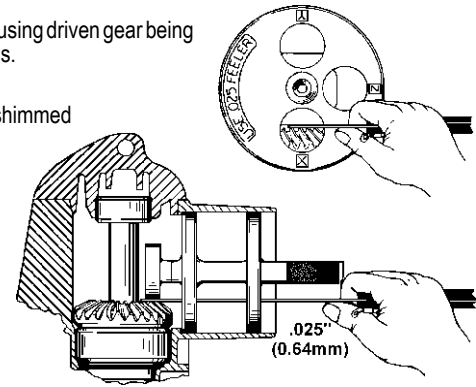
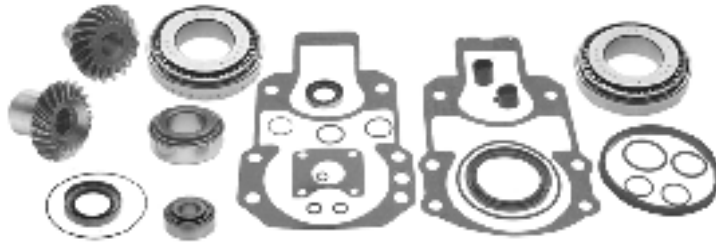

FIG. #3 - #4



18-2256
UPPER GEAR SET
Replaces: 43-803116T1
Most V-8 Drives (1.5:1 Ratio)

— CONTAINS —

Sierra#	Description	O.E.#	Qty.
18-2201	Upper Unit Gear Set	43-18410A2	1
18-2648	Seal Kit	26-32511A2	1
18-2618	Outdrive Gasket Set	27-94996A1	1
18-2820	Drive Shaft Housing to Bell Housing Gasket	27-64818	1
18-2743	Drive Shaft Housing to Bell Housing Gasket	27-94996-2	1
18-1160	Bearing	31-35988A2	1
18-1165	Bearing	31-61100A1	1
18-1142	Bearing	31-35990A1	1

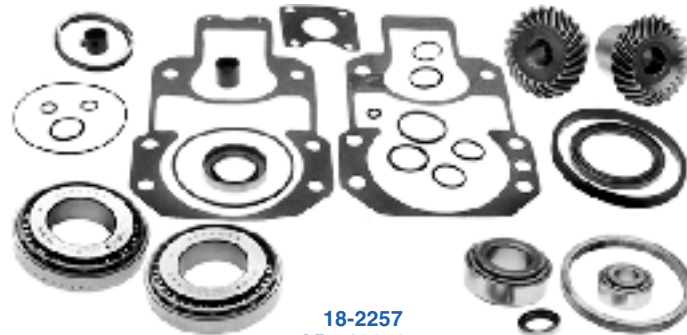

18-2257
AP# 13078
UPPER GEAR SET
Replaces: 43-803112T1
6 Cyl. Inline (1.65:1 Ratio)

— CONTAINS —

Sierra#	Description	O.E.#	Qty.
18-2203	Gear Set	43-45814A5	1
18-2648	Seal Kit	26-32511A2	1
18-2618	Outdrive Gasket Set	27-94996A1	1
18-2820	Drive Shaft Housing to Bell Housing Gasket	27-64818	1
18-1160	Bearing	31-35988A2	1
18-1161	Bearing	31-35990A1	1
18-1165	Bearing	31-61100A1	1
18-2743	Drive Shaft Housing to Bell Housing Gasket	27-94996-2	1



18-2258
AP# 13079
UPPER GEAR SET
Replaces: 43-803114T1
V-6 (470/485) (1.84:1 Ratio)

— CONTAINS —

Sierra#	Description	O.E.#	Qty.
18-2204	Gear Set	43-75325A3	1
18-2648	Seal Kit	26-32511A2	1
18-2618	Outdrive Gasket Set	27-94996A1	1
18-2820	Drive Shaft Housing to Bell Housing Gasket	27-64818	1
18-1160	Bearing	31-35988A2	1
18-1161	Bearing	31-35990A1	1
18-2743	Drive Shaft Housing to Bell Housing Gasket	27-94996-2	1
18-1165	Bearing	31-61100A1	1

MERCUISER

Drive System





 <p>18-2259 AP# 13080 UPPER GEAR SET Replaces: 43-803101T1 120/140 (1.98:1 Ratio)</p>			<p>— CONTAINS —</p> <table border="1"> <thead> <tr> <th>Sierra#</th> <th>Description</th> <th>O.E. #</th> <th>Qty.</th> </tr> </thead> <tbody> <tr> <td>18-2205</td> <td>Gear Set</td> <td>43-55778A3</td> <td>1</td> </tr> <tr> <td>18-2648</td> <td>Seal Kit</td> <td>26-32511A2</td> <td>1</td> </tr> <tr> <td>18-2618</td> <td>Outdrive Gasket Set</td> <td>27-94996A1</td> <td>1</td> </tr> <tr> <td>18-2820</td> <td>Drive Shaft Housing to Bell Housing Gasket</td> <td>27-64818</td> <td>1</td> </tr> <tr> <td>18-1160</td> <td>Bearing</td> <td>31-35988A2</td> <td>1</td> </tr> <tr> <td>18-1161</td> <td>Bearing</td> <td>31-35990A1</td> <td>1</td> </tr> <tr> <td>18-1165</td> <td>Bearing</td> <td>31-61100A1</td> <td>1</td> </tr> <tr> <td>18-2743</td> <td>Drive Shaft Housing to Bell Housing Gasket</td> <td>27-94996-2</td> <td>1</td> </tr> </tbody> </table>			Sierra#	Description	O.E. #	Qty.	18-2205	Gear Set	43-55778A3	1	18-2648	Seal Kit	26-32511A2	1	18-2618	Outdrive Gasket Set	27-94996A1	1	18-2820	Drive Shaft Housing to Bell Housing Gasket	27-64818	1	18-1160	Bearing	31-35988A2	1	18-1161	Bearing	31-35990A1	1	18-1165	Bearing	31-61100A1	1	18-2743	Drive Shaft Housing to Bell Housing Gasket	27-94996-2	1
			Sierra#	Description	O.E. #	Qty.																																			
18-2205	Gear Set	43-55778A3	1																																						
18-2648	Seal Kit	26-32511A2	1																																						
18-2618	Outdrive Gasket Set	27-94996A1	1																																						
18-2820	Drive Shaft Housing to Bell Housing Gasket	27-64818	1																																						
18-1160	Bearing	31-35988A2	1																																						
18-1161	Bearing	31-35990A1	1																																						
18-1165	Bearing	31-61100A1	1																																						
18-2743	Drive Shaft Housing to Bell Housing Gasket	27-94996-2	1																																						
 <p>18-9218 DRIVE SHAFT Replaces: 814819A2 For all #1, R/MR/ALPHA Generation II - Drives with V-6 & V-8 powerheads. In-line engines not included.</p>	 <p>18-2146 AP# 2421 YOKE ASSEMBLY, UNIVERSAL JOINT - COUPLING END Replaces: 59830A1, A7 Fits all #1, R, MR, Alpha I, Alpha I Gen II, Bravo & Blackhawk</p>	 <p>18-6400 YOKE Replaces: 12784 For: Bravo</p>																																							
<p>NEW</p>  <p>18-1711 U-JOINT Replaces: 862132T For: Bravo</p>	 <p>18-6401 U-JOINT ASSEMBLY Replaces: 12784A10 For Bravo</p>	 <p>18-2128 AP# 1440 CENTER SOCKET Replaces: 39383T, 343831 (Rockwell) Fits all #1 Alpha Units above S/N 1684188; TR/TRS & II SSM; Bravo</p>																																							
<p>NEW</p>  <p>18-1709 YOKE ASSEMBLY Replaces: 862129A1 For: Bravo</p>	 <p>18-2125 AP# 3800 YOKE ASSEMBLY Replaces: 46020T Fits all #1/ALPHA Units above S/N 1684188</p>	 <p>18-2104 HEAVY DUTY U-JOINT Replaces: 75832A2, 75832T Includes both straight and 90° grease fitting. (Rockwell) Fits all #1 and ALPHA I Units S/N 1684188-B418818. Also TR/TRS and II SSM.</p>																																							

1/0

 <p>18-2174 AP# 1821 HEAVY DUTY U-JOINT Replaces: 75832A3, 758321, 75832T1 Includes both straight and 90° grease fitting.(Rockwell) Fits ALPHA I Units S/NB418819 & above. Also fits ALPHA I SS & BRAVO</p>	 <p>18-2097 AP# 13043 PERMALUBE U-JOINT Replaces: 805536A2 For: Generation II F680000 & UP</p>	 <p>18-2101 AP# 13044 GIMBAL BEARING Replaces: 30-36418 (Link-Belt)</p>
 <p>18-2100 AP# 803 GIMBAL BEARING Replaces: 30-60794A4 (Link-Belt)</p>	 <p>18-2381 AP# 2674 UPPER DRIVE UNIT CAP Replaces: 94998A2 SN 6225577 & Later Alpha I, except Gen II</p>	 <p>18-2382 UPPER DRIVE UNIT CAP Replaces: 828692A1 For: Gen II SN F680000 & UP</p>

GIMBAL BEARING APPLICATION





Stern Drive Model	Beginning Serial No.	Ending Serial No.	Sierra Gimbal Bearing	AP Gimbal Bearing	Stern Drive Model	Beginning Serial No.	Ending Serial No.	Sierra Gimbal Bearing	AP Gimbal Bearing
IA	1684186	2062140	18-2101	—	165	4890460	& UP	18-2100	803
IB	1684633	2062140	18-2101	—	225S	3856268	4200499	18-2100	803
IC	1685240	2065189	18-2101	—	228	4782330	& UP	18-2100	803
II	1602186	2278488	18-2101	—	233	4200500	& UP	18-2100	803
II	2398798	2671321	18-2101	—	250	4791300	& UP	18-2100	803
120, 140	2062141	2791956	18-2101	—	470	4208730	& UP	18-2100	803
120, 140	2791957	4893634	18-2101 ①	—	888	3106717	& UP	18-2101 ①	—
120, 140	2791957	4893634	18-2100 ②	803 ②	888	3106717	& UP	18-2100 ②	803 ②
160	2065190	2763441	18-2101	—	898	4782330	& UP	18-2100	803
165	2763442	4890459	18-2101 ①	—	ALL #1 + ALPHA	4893635	& UP	18-2100	803
165	2763442	4890459	18-2100 ②	803 ②					
① Without Gimbal Trim Sender ② With Gimbal Trim Sender					Bravo	ALL		18-2100	803

 <p>18-2179 AP# 2632 UPPER DRIVE SHAFT Replaces: 45-55796</p>	 <p>18-2324 AP# 2633 UPPER DRIVE SHAFT Replaces: 45-55796-1 For: Gen II (S/N F680000 & UP)</p>	 <p>18-3713 AP# 1817 LOCK NUT Replaces: 11-22339 5/8" - 18</p>	 <p>18-3712 AP# 2716 YOKE WASHER Replaces: 12-45810</p>	 <p>18-3752 AP# 2673 RETAINING NUT DRIVE SHAFT HOUSING Replaces: 816811-1</p>
 <p>18-4296 AP# 2724 RING Replaces: 35983 (Upper Housing)</p>	 <p>18-0577 AP# 3806 CARRIER ASSEMBLY OIL SEAL Replaces: 66081A2</p>	 <p>18-3219 AP# 1813 WATER HOUSING KIT Replaces: 42724A3 For: Merc I and Alpha I drives Models: I, 1A, 1B, 1C, 1CEZ, 120, 140, 160, 165, 888, 898, 228, 225-S, 233, 250, 260, 470, 485, R, MR, Alpha 18-3229 BOLT Replaces: 10-28668</p>	 <p>18-2322 AP# 2692 INTERMEDIATE SHAFT ASSEMBLY Replaces: 62104-1 For: I and Alpha I</p>	





MERCUISER Drive System



 <p>18-2169 AP# 1762 SHIFT ARM Replaces: 45589A3</p>	 <p>18-3749 UPPER SHIFT SHAFT Replaces: 816685 For: Alpha Gen II (1991-98)</p>	 <p>18-2599 AP# 2106 FACE SEAL Replaces: 26-816575A2 For: ALPHA I GENERATION II</p>	 <p>18-2622 AP# 3811 BELL HOUSING BUSHING KIT Replaces: 23-805041A2</p>
--	---	---	---

 <p>18-3760 SHIFT SHAFT BUSHING KIT Replaces: 23-806036A1 For: GEN II Serial # F680000 & UP</p>	 <p>18-2161 AP# 1358 SHIFT ARM Replaces: 45518A2</p>	 <p>18-2170 AP# 1763 SHIFT ARM SCREW Replaces: 10-45590</p>	 <p>18-2162 AP# 1028 SHIFT SLIDE AND SCREW Replaces: 33981T</p>
--	--	--	---

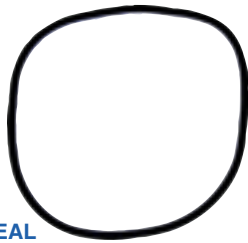
<p>PKG. OF 2</p>  <p>18-2163 AP# 1330 SHIFT SLIDE SCREW Replaces: 10-31700</p>	 <p>18-2715 AP# 2382 CHECK VALVE KIT Replaces: 24-17997A1 For: Alpha I Generation II and Bravo I, II, and III Drives</p>	 <p>18-2724 TRANSOM SEAL Replaces: 3713 For: Alpha Gen II, All Bravo</p>
---	--	--

— CONTAINS —

Sierra#	Description	O.E.#	Qty.
18-2618	Outdrive Gasket Set	27-94996A1	1
18-2100	Gimbal Bearing	30-60794A4	1
18-2161	Shift Arm	45518A2	1
18-2751	U-Joint Bellows	60932A4	1
18-2750	Exhaust Bellows	32734A3, 18654A1	1
18-2753-1	Shift Cable Bellows	74639	1
18-7314	Stainless Steel Hose Clamp	—	1
18-7315	Stainless Steel Hose Clamp	—	1

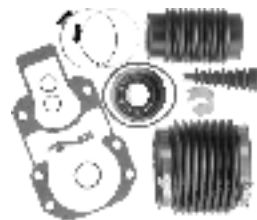

18-2601
TRANSOM SEAL KIT
Replaces: AM1000
#1 (S/N 3469428 and up)

— CONTAINS —

Sierra#	Description	O.E.#	Qty.
18-2100	Gimbal Bearing	30-60794A4	1
18-2751	U-Joint Bellows	60932A4	1
18-2760	Exhaust Tube	78458A1	1
18-3601	Water Intake Hose	32-32461	1
18-3602	Water Intake Hose	32-41725-33	1
18-2743	Drive Shaft Housing to Bell Housing Gasket	27-94996-2	1
18-2840	Bell Housing Gasket	27-35982	1
18-7153	O-Ring	25-25439	1
18-7117	O-Ring	25-35027	1
18-7310	Hose Clamp	—	2
18-7170	O-Ring	25-33504	1
18-7312	Hose Clamp	—	1
18-2753-1	Shift Cable Bellows	74639	1
18-7321	Bellows Clamp	54-38863	1



18-8205
TRANSOM SEAL KIT
Replaces: 30-803098T1
For: 1, R, MR, Alpha 1 with exhaust tube

— CONTAINS —

Sierra#	Description	O.E.#	Qty.
18-2753-1	Shift Cable Bellow	74639	1
18-2100	Gimbal Bearing	30-60794A4	1
18-2756	U-Joint Bellows	86840A3	1
18-2750	Exhaust Bellows	32734A3	1
18-2760	Exhaust Tube	78458A1	1
18-3603	Water Hose	32-43437	1
18-2615	Outdrive Mounting Kit	16755A1	1



18-8212
TRANSOM SEAL KIT
Replaces: 30-803100T1
For: All Bravos 1982 & up

1/1

— CONTAINS —

Sierra#	Description	O.E.#	Qty.
18-3602	Water Intake Hose	32-41725-33	1
18-7310	Hose Clamp	—	2
18-7312	Hose Clamp	—	1
18-2753-1	Shift Cable Bellows	74639	1
18-7321	Bellows Clamp	54-38863	1
18-2100	Gimbal Bearing	30-60794A4	1
18-2743	Drive Shaft Housing to Bell Housing Gasket	27-94996-2	1
18-2840	Bell Housing Gasket	27-35982	1
18-7153	O-Ring	25-25439	1
18-7170	O-Ring	25-33504	1
18-7117	O-Ring	25-35027	1
18-2750	Exhaust Bellows	18654A1, 32734A3	1
18-2747	Drive Bellows	816431A1	1



18-8206
TRANSOM SEAL KIT
Replaces: 30-803099T1
For: Alpha 1 Gen II



18-2752
AP# 2185
U-JOINT BELLOWS
All #1 units without ridge
(S/N 3443920 & BELOW)
Replaces: 36223A2
(Includes 18-7316/AP# 096 Clamp)



18-2751
AP# 511
U-JOINT BELLOWS
All #1 units with ridge (S/N 3469428 & UP)
Replaces: 60932A4
(Includes 18-7316/AP# 096 Clamp)



18-2747
AP# 2691
U-JOINT BELLOWS
Alpha 1, Gen II
Replaces: 816431A1



18-2756
AP# 2690
DRIVE SHAFT BELLOWS
Replaces: 86840A3
For all #2 Bravo units



18-2750
AP# 500
EXHAUST BELLOWS
All #1 Units, Gen II,
TRS, & Bravo I, II, III
Replaces: 32734A3, 18654A1
(Includes 18-7314 Clamp)



18-2753-1 ①
18-2753-1N ②
AP# 2665
SHIFT CABLE BELLOWS
All #1, #2 units, Alpha, Bravo I, II, III
Replaces: 74639
(Includes 18-7321/AP# 2650 Clamp)

BELLOWS APPLICATION

Model	Years	Serial #	Exhaust Bellows	Shift Cable Bellows	U-Joint Bellows
I/1A/1B/1C & EZ	1963-1966	1534570-2065186	18-2750	18-2753-1	18-2752
120/140/160/165	1967-1972	2062141-3443920	18-2750	18-2753-1	18-2752
120/140/160/165	1972-1982	3469428-6225576	18-2750	18-2753-1	18-2751
888	1971-1972	3106717-3472477	18-2750	18-2753-1	18-2752
888	1973-1977	3472478 & Up	18-2750	18-2753-1	18-2751
225/233	1974-1977	3856268 & Up	18-2750	18-2753-1	18-2751
898/228/250/260	1977-1982	4782330-6225576	18-2750	18-2753-1	18-2751
R/MR/Alpha One	1983-1990	6225577 & Up	18-2750	18-2753-1	18-2751
R/MR/Alpha One	1983-1990	6225577 & Up	18-2760 ③	18-2753-1	18-2751
Alpha One Gen II	1991 & Newer	0D469859 & Up	18-2750	18-2753-1	18-2747
Bravo I/II/III	1988 & Newer	0B664190 & Up	18-2750	18-2753-1	18-2756
Bravo I/II/III	1988 & Newer	0B664190 & Up	18-2760 ③	18-2753-1	18-2756
Blackhawk	1994-1995	0F18677 & Up	18-2750	18-2753-1	18-2756
Blackhawk	1994-1995	0F18677 & Up	18-2760 ③	18-2753-1	18-2756
II	1962-1969	1474909-2671321	—	18-2753-1	—
III	1968-1972	2373127-3002613	—	—	—
215H	1970	2782203-2909034	—	—	18-2752
215E	1970-1972	2909035-2915034	—	18-2753-1	18-2752
TR/TRS	1973-1993	3377316 & Up	—	—	18-2751
TR/TRS	1973-1993	3377316 & Up	—	—	18-2751

③ Tube

① Display Pack ② Bulk Pack



MERCUISER

Drive System



 <p>18-9031 AP# 13586 BELLOWS ADHESIVE Replaces: 92-86166</p> <p>Display Package</p>	<p>PKG. OF 2</p>  <p>18-7321 AP# 2650 BELLOWS CLAMP Replaces: 54-38863</p>	 <p>18-2732 WATER SHUTTER Replaces: 807166A3</p>	 <p>18-2733 WATER SHUTTER Replaces: 99370A2</p>
 <p>18-2727 EXHAUST WATER SHUTTER Replaces: 0930</p>	 <p>18-2746 AP# 1525 EXHAUST BOOT Replaces: 32-14358T (4" Lower Tube)</p>	 <p>18-2748 AP# 1520 EXHAUST BOOT Replaces: 32-44348T (4" Upper Tube)</p>	 <p>18-2759 AP# 502 EXHAUST TUBE Replaces: 53114A1</p>
 <p>18-2760 AP# 519 EXHAUST TUBE Replaces: 78458A1 (Includes 18-7314 Clamp) For: #1, Bravo I, II, III</p>	<p>INNER SHIFT CABLE</p> <p>18-2159 AP# 13057 Replaces: 66069A2 Use in 18-2157, 18-2158 and their Mercruiser equivalent as replacement wire and tube Stranded Core 73"</p> <p>18-2189 AP# 13060 Replaces: 38399A2 Use with 18-2248 Inner Core Wire 59"</p> 	 <p>18-2160 SHIFT CABLE SUPPORT TUBE Replaces: 32-38377 Replaces tube on 18-2157, 18-2158/AP# 13056 & 18-2159/AP# 13057</p>	
<p>18-2248 SHIFT CABLE ASSEMBLY Replaces: 73723A1 Mercruiser #1 Drives S/N 1562900-6225576 for forward installation into bell housing. Has new style armored strand construction. (No support tube) 54" conduit with hardware package.</p> 	<p>SHIFT CABLE ASSEMBLY</p> <p>18-2157 Replaces: 41951A1, 19543A4 Mercruiser 1 drives S/N 6225577 & UP For AFT installation into bell housing. Has old style stranded core wire with soldered tip (Uses Support Tube).</p> <p>18-2158 AP# 13056 Mercruiser #1 Drives S/N 1562900-6225576 for forward installation into bell housing. Has old style stranded core wire with soldered tip. (Uses support tube) 63" conduit</p> 		

 <p>18-2190 AP# 1764 SHIFT CABLE ASSEMBLY Replaces: 19543A4, A10 Mercruiser 1 drives S/N 6225577 & UP For AFT installation into bell housing. For use in applications using core wire with armored strand construction (No Support Tube). 63" Conduit with hardware package.</p>	<p>NEW</p> <p>TFX TREME</p>  <p>18-2145E BRAVO SHIFT CABLE Replaces: 815471, A3, A6 Brave lower shift cable</p>																																									
 <p>18-2145 AP# 2387 BRAVO SHIFT CABLE Replaces: 815471A3, A6</p>	<p>NEW</p> <p>TFX TREME</p>  <p>18-2149E GUIDE END KIT Replaces: 43433 For: Alpha & Bravo cables</p>																																									
 <p>18-2149 AP# 2644 GUIDE END KIT Replaces: 43433 For: Alpha & Bravo cables</p>	<p>NEW</p> <p>TFX TREME</p>  <p>18-2190E SHIFT CABLE ASSEMBLY Replaces: 19543A4, 19543A10 S/N 6225577 & UP For AFT installation into bell housing. For use in applications using core wire with armored strand construction (No Support Tube). 63" Conduit with hardware package.</p>																																									
 <p>18-2303 AP# 2646 CABLE ANCHOR SET SCREW Replaces: 10-20518 For: #1R, MR, Alpha, Alpha I, Gen II & Bravo</p>	 <p>18-3754 AP# 2645 CABLE ANCHOR Replaces: 43436 For: #1R, MR, Alpha, Alpha I, Gen II & Bravo</p>	 <p>18-2600 LOWER SHIFT CABLE KIT — CONTAINS —</p> <table border="1"> <thead> <tr> <th>Sierra#</th> <th>Description</th> <th>O.E.#</th> <th>Qty.</th> </tr> </thead> <tbody> <tr> <td>18-2618</td> <td>Outdrive Gasket Set</td> <td>27-94996A1</td> <td>1</td> </tr> <tr> <td>18-2753-1</td> <td>Shift Cable Bellows</td> <td>74639</td> <td>1</td> </tr> <tr> <td>18-2158</td> <td>Shift Cable Assembly</td> <td>73723A1</td> <td>1</td> </tr> <tr> <td>18-2162</td> <td>Shift Slide & Screw</td> <td>33981T</td> <td>1</td> </tr> <tr> <td>18-2149</td> <td>Shift Cable End Kit</td> <td>43433</td> <td>1</td> </tr> <tr> <td>18-2163</td> <td>Shift Slide Screw</td> <td>10-31700</td> <td>1</td> </tr> <tr> <td>18-2743</td> <td>Drive Shaft Housing to Bell Housing Gasket</td> <td>27-94996-2</td> <td>1</td> </tr> <tr> <td>18-2820</td> <td>Drive Shaft Housing to Bell Housing Gasket</td> <td>27-64818</td> <td>1</td> </tr> <tr> <td>18-2842</td> <td>Drive Shaft Housing to Bell Housing Gasket</td> <td>27-94996</td> <td>1</td> </tr> </tbody> </table>	Sierra#	Description	O.E.#	Qty.	18-2618	Outdrive Gasket Set	27-94996A1	1	18-2753-1	Shift Cable Bellows	74639	1	18-2158	Shift Cable Assembly	73723A1	1	18-2162	Shift Slide & Screw	33981T	1	18-2149	Shift Cable End Kit	43433	1	18-2163	Shift Slide Screw	10-31700	1	18-2743	Drive Shaft Housing to Bell Housing Gasket	27-94996-2	1	18-2820	Drive Shaft Housing to Bell Housing Gasket	27-64818	1	18-2842	Drive Shaft Housing to Bell Housing Gasket	27-94996	1
Sierra#	Description	O.E.#	Qty.																																							
18-2618	Outdrive Gasket Set	27-94996A1	1																																							
18-2753-1	Shift Cable Bellows	74639	1																																							
18-2158	Shift Cable Assembly	73723A1	1																																							
18-2162	Shift Slide & Screw	33981T	1																																							
18-2149	Shift Cable End Kit	43433	1																																							
18-2163	Shift Slide Screw	10-31700	1																																							
18-2743	Drive Shaft Housing to Bell Housing Gasket	27-94996-2	1																																							
18-2820	Drive Shaft Housing to Bell Housing Gasket	27-64818	1																																							
18-2842	Drive Shaft Housing to Bell Housing Gasket	27-94996	1																																							
 <p>18-2603 AP# 2823 LOWER SHIFT CABLE KIT Replaces: 19543T-1 ALPHA I GENERATION II — CONTAINS —</p> <table border="1"> <thead> <tr> <th>Sierra#</th> <th>Description</th> <th>O.E.#</th> <th>Qty.</th> </tr> </thead> <tbody> <tr> <td>18-2619</td> <td>Outdrive Gasket Set</td> <td>27-94996A1</td> <td>1</td> </tr> <tr> <td>18-2753-1</td> <td>Shift Cable Bellows</td> <td>74639</td> <td>1</td> </tr> <tr> <td>18-2190</td> <td>Shift Cable Assembly</td> <td>19543A4</td> <td>1</td> </tr> <tr> <td>18-2743</td> <td>Drive Shaft Housing to Bell Housing Gasket</td> <td>27-94996-2</td> <td>1</td> </tr> </tbody> </table>	Sierra#	Description	O.E.#	Qty.	18-2619	Outdrive Gasket Set	27-94996A1	1	18-2753-1	Shift Cable Bellows	74639	1	18-2190	Shift Cable Assembly	19543A4	1	18-2743	Drive Shaft Housing to Bell Housing Gasket	27-94996-2	1	 <p>18-2604 AP# 2824 LOWER SHIFT CABLE KIT Replaces: 815471T-1 BRAVO — CONTAINS —</p> <table border="1"> <thead> <tr> <th>Sierra#</th> <th>Description</th> <th>O.E.#</th> <th>Qty.</th> </tr> </thead> <tbody> <tr> <td>18-2145</td> <td>Bravo Shift Cable</td> <td>815471A3</td> <td>1</td> </tr> <tr> <td>18-2149</td> <td>Shift Cable End Kit</td> <td>43433</td> <td>1</td> </tr> <tr> <td>18-2753-1</td> <td>Shift Cable Bellows</td> <td>74639</td> <td>1</td> </tr> <tr> <td>18-2615</td> <td>Outdrive Gasket Set</td> <td>—</td> <td>1</td> </tr> </tbody> </table>	Sierra#	Description	O.E.#	Qty.	18-2145	Bravo Shift Cable	815471A3	1	18-2149	Shift Cable End Kit	43433	1	18-2753-1	Shift Cable Bellows	74639	1	18-2615	Outdrive Gasket Set	—	1	
Sierra#	Description	O.E.#	Qty.																																							
18-2619	Outdrive Gasket Set	27-94996A1	1																																							
18-2753-1	Shift Cable Bellows	74639	1																																							
18-2190	Shift Cable Assembly	19543A4	1																																							
18-2743	Drive Shaft Housing to Bell Housing Gasket	27-94996-2	1																																							
Sierra#	Description	O.E.#	Qty.																																							
18-2145	Bravo Shift Cable	815471A3	1																																							
18-2149	Shift Cable End Kit	43433	1																																							
18-2753-1	Shift Cable Bellows	74639	1																																							
18-2615	Outdrive Gasket Set	—	1																																							

MERCUISER Drive System



18-2761
AP# 520
EXHAUST TUBE
3" I.D.
Replaces: 32-90949T



18-2762
AP# 503
EXHAUST TUBE
Replaces: 70981A3



18-2770
EXHAUST TUBE
Replaces: 32-807458T

STAINLESS STEEL CLAMPS			
Sierra #	AP #	Diameter Size	Std. #
18-7307	—	9/16" to 7/8"	006
18-7308	—	9/16" to 1 1/16"	010
18-7309	—	9/16" to 1 1/4"	012
18-7310	—	1 1/16" to 1 1/2"	016
18-7311	—	3/4" to 1 3/4"	020
18-7312	—	1 1/16" to 2"	024
18-7313	—	1 9/16" to 2 1/2"	032
18-7314	—	2 9/16" to 3 1/2"	048 ②
18-7315	590	2 1/2" to 4 1/2"	064
18-7316 ③	096	3" to 5"	072
18-7317	—	5" to 7"	104
18-7318 ④	—	1 21/64" to 1 3/4"	①
18-7320	1685	3 1/8" to 4"	①

① For use with 3" Bellows ② O.E. #54-32533 ③ O.E. #'s 54-31765, 54-815504372 ④ PKG OF 2

**GRADE 316
STAINLESS STEEL WORM
GEAR HOSE CLAMPS**



All components are manufactured from Marine Grade 316 stainless steel. These clamps are designed to fit many applications from 9/16" to 7" diameter hoses.



18-2175
AP# 13058
ENGINE COUPLER KIT
Replaces: 18643A7
Flex plate style for late model, small crankshaft bolt pattern, style engines



18-2195
AP# 13062
ENGINE COUPLER KIT
Replaces: 12632A7
Flex plate style for GM 4 Cyl Engines with late style, small crankshaft bolt pattern



18-2323
ENGINE COUPLER
Replaces: 18643A5
(Same as 18-2175 without yoke)



18-2321
ENGINE COUPLER
Replaces: 12632A6
(Same as 18-2195 without yoke)





18-2413
ENGINE COUPLER ASSEMBLY
Replaces: 69354A2
For: 470, 485 (224 cu. in.)
S/N 4208730-6218036 (1976-1982)



18-2414
ENGINE COUPLER ASSEMBLY
Replaces: 97432A2
For: 165, 170, 470, 3.7L S/N 6170297 & UP (1983-1989)
180, 190, 488, 3.7LX S/N 6170297 & UP (1983-1989)

ENGINE COUPLER APPLICATION ON NEXT PAGE

I/O

 <p>18-2171 AP# 1446 ENGINE COUPLER Replaces: 76850A2 For all GM Engines Except MR/ALPHA/BRAVO with "Triangular", 3-Bolt Coupler</p>	 <p>18-2172 AP# 1847 ENGINE COUPLER Replaces: 14505-A2 Use when new style block, with small crankshaft end, is replacing a Mercruiser block</p>	 <p>18-2173 AP# 1848 ENGINE COUPLER Replaces: 59826A3 For Ford Engines</p>
--	--	--

ENGINE COUPLER APPLICATION

Model	Serial #		Model	Serial #	
110	1537370-2044030	18-2171	200 (5.0L)	B525982 & UP	18-2175 ⑦
120	1537370-6229717	18-2171	205 (262 CID)	A331455 & UP	18-2171 ① 18-2172 ⑤ 18-2175 ② ⑦
120 (2.5L)	6229718 & UP	18-2171 ① 18-2195 ② ⑥ 18-2172 ④	205 (4.3L)	B5257955 & UP	18-2175 ⑦
140	2508261-6229717	18-2171	(Generation II)	D714370 & UP	18-2175 ⑦
140 (3.0L)	6229718 & UP	18-2171 ① 18-2195 ② ⑥ 18-2172 ④	225	1539620-2694014	18-2171
140 (6 Cyl)	1538930-1725960	18-2171	225 & 225 S Ford	3385721 & UP	18-2173
3.0L/3.0LX	C856559-F000000	18-2195 ⑥	228	4765100-6218461	18-2171
150	1666495-2048046	18-2171	228	6218462 & UP	18-2171 ① 18-2175 ② ⑦ 18-2172 ⑤
160	2048022-2770031	18-2171	230	6218462 & UP	18-2171 ① 18-2175 ② ⑦ 18-2172 ⑤
165 (6 Cyl)	2770032 & UP	18-2171	230 (5.0L)	B525982 & UP	18-2175 ⑦
175 (4.3L)	B527955 & UP	18-2175 ⑦	233 Ford	4173000 & UP	18-2173
470/485 (224 CID) 3.7L	4208730- 6218036	18-2413	250	4768000-4908849	18-2171
165/ 170/ 470 3.7L	6170297 & UP	18-2414	260	4908850-6218461	18-2171
4.3L (Generation II)	D714107 & UP	18-2175 ⑦	260	6218462 & UP	18-2171 ① 18-2175 ② ⑦ 18-2172 ⑤
185 (229 CID)	6330183 & UP	18-2171	All Mercruiser w/ Bravo Drive	-	18-2412
185 (262 CID)	A331455 & UP	18-2171 ① 18-2175 ② ⑦ 18-2172 ⑤	260 (5.7L)	B5259812 & UP	18-2175 ⑦
888 Ford (188 HP)	3108723 & UP	18-2173	300 MR	6668677 & UP	18-2171 ③ 18-2175 ④ ⑦
190	1564539 -1730903	18-2171	320 EFI	A543604 & UP	18-2175 ⑦
898 (198 HP)	4762210 & UP	18-2171 ① 18-2175 ② ⑦	350 Magnum	A635178 & UP	18-2175 ⑦
200	6218462 & UP	18-2171 ① 18-2172 ⑤ 18-2175 ② ⑦	454 Magnum	A631894 & UP	18-2175 ⑦
			5.7L (Bravo)	B525982 & UP	18-2175 ⑦









- ① Early Models ② Late Models ③ MR Cast Coupling
④ MR Stamped Coupling
⑤ General Motors has changed the V-6 and V-8 cylinder block and crankshaft to incorporate a one-piece full circle rear seal. For this change to be made, General Motors had to redesign the cylinder block and crankshaft discontinuing the earlier style engines. Mercury has added engine coupler # 14505-A2 (**18-2172**) to compensate for this change in design.
⑥ For engine coupler w/o yoke use **18-2321**
⑦ For engine coupler w/o yoke use **18-2323**

 <p>18-4442 AP# 13334 ENGINE ALIGNMENT TOOL Replaces: 91-57797A3 For use with all #1 units</p>	 <p>18-9803 BEARING RETAINER WRENCH Replaces: 91-36235</p>	 <p>18-9200 AP# 13587 SPLINE GREASE 14 oz. Replaces: 92-816391A4 Specialty grease used in the assembly of engine yokes and couplers</p>
--	--	---



Features...

- ★ Manufactured to the strictest specifications.
- ★ Forward and reverse gears made from 8620 bearing quality steel. Pinion is made from 9310 bearing quality steel.
- ★ All gears are made from forged steel blanks.
- ★ Precision cutting processes are used to hold precise tolerances.
- ★ Heat treat specifications are batch certified.
- ★ Available in individual sets or in convenient complete repair kits.
- ★ Sierra offers all the right parts to do the job right.

 <p>18-2200 LOWER UNIT GEAR SET Replaces: 43-96084A4 888 S/N 3106717 & UP #1 Units S/N 3469428 & UP Except, MR/ALPHA Units (which have no pre-load pin in the top of the drive shaft).</p>	 <p>18-2410 FORWARD GEAR SET Replaces: 43-96084A7 For: "R" drive</p>	 <p>18-2360 PINION AND FORWARD GEAR SET Replaces: 43-828072A3 13-21 Teeth</p>
 <p>18-2409 REVERSE GEAR Replaces: 43-92320T For: "R" drive (28 teeth)</p>	 <p>18-2206 ① AP# 2352 LOWER ALPHA GEAR SET Replaces: 43-17064A3 + 43-42934, 43-17064A2 Gear Set ① When installing new style 18-2206/AP# 2352 "Tractor Gears" in Alpha One Gear Housing (F680153 & BELOW) with a 3.4985 - 3.5000 forward bearing bore use Forward Bearing 18-1173. Alpha One Gear Housing (F680154 & UP) with a 3.2635/ 3.2650 forward bearing bore, use Forward Bearing 18-1156/AP# 1906.</p>	
 <p>18-2356 COMPLETE LOWER HOUSING GEAR SET Replaces: 43-828072A3, 43-828073A1 13-21 Teeth For: 1996 & up Serial Number F680000 & up Uses our 18-1156 forward bearing with 3.265 O.D.</p>	 <p>18-2406 FORWARD GEAR SET Replaces: 43-878087A2 For: MR/Alpha/Gen II lower S/N D469859 & UP</p>	 <p>18-2408 REVERSE GEAR Replaces: 43-828073A1 For: Alpha I/Gen II lower S/N D469859 & UP</p>

18-2404
GEAR REPAIR KIT
Replaces: 43-803079T1
For: "R" drive



— CONTAINS —

Sierra #	Description	O.E. #	Qty.
18-2200	Lower Unit Gear Set	43-96084A4	1
18-2202	Sliding Clutch	52-66063	1
18-1157	Needle Roller Bearing	31-30895	1
18-1155	Ball Bearing	30-88957A1	1
18-1159	Tapered Roller Bearing	31-35928A1	1
18-2285	Shim	15-47397	1
18-3719	Pinion Nut	11-35921	1
18-2299	Tab Washer	14-79447	1

18-2405
GEAR REPAIR KIT
Replaces: 43-803091T1
For: MR/Alpha I



— CONTAINS —

Sierra #	Description	O.E. #	Qty.
18-2652	Lower Gear Housing Seal Kit	26-33144A2	1
18-3719	Pinion Nut	11-35921	1
18-2343	Washer	12-982721	1
18-2298	Tab Washer	14-18323	1
18-2299	Tab Washer	14-79447	1
18-2206	Gear Set	43-42934	1
18-2285	Shim	15-47397	1
18-1155	Ball Bearing	30-88957A1	1
18-1158	Needle Roller Bearing	31-30956	1
18-1117	Pinion Bearing	31-42647A1	1
18-1143	Alpha Bearing	31-36387A1	1
18-2294	Shim Kit	2470	1
18-2202	Sliding Clutch	52-66063	1



18-2368
GEAR REPAIR KIT
Replaces: 43-80371T1
ALPHA/GEN II 1996-97



18-2369
GEAR REPAIR KIT
Replaces: 43-803069T1
ALPHA/GENII 1991-95

18-2407
GEAR SET
Replaces:
43-878087A4
For: MR/Alpha/Gen II
lower gear housings



— CONTAINS —

Sierra #	Description	O.E. #	Qty.
18-2206	Gear Set	43-42934	1
18-1155	Ball Bearing	30-88957A1	1
18-1117	Pinion Bearing	31-42647A1	1
18-1158	Needle Roller Bearing	31-30956	1
18-1143	Alpha Bearing	31-36387A1	1
18-2294	Shim Kit	2470	1
18-2285	Shim	15-47397	1
18-3719	Pinion Nut	11-35921	1
18-2343	Washer	12-982721	1



18-2202
AP# 2415
SLIDING CLUTCH
Replaces: 52-66063
888 S/N 3784375 & UP
#1 Units S/N 3469428 & UP



18-2357
AP# 2682
CROSS PIN
Replaces: 17-30632



18-2348
CLUTCH CROSS
PIN SPRING
Replaces: 24-30893
1/MC-1/R/MR/Alpha
Mercruiser/Gen II lower
S/N D469859-F679999

MERCURISER









Features...

- ★ Our shafts are made using state-of-the-art techniques with precision bi-metal components.
- ★ Inertia or friction welding combines 8620 bearing quality steel with 17-4 PH stainless steel to produce a shaft with durable bearing properties.

 <p>18-2166 AP# 1802 PROP SHAFT Replaces: 44-66060, 44-66060-3, 44-824110 For all #1 & MR/ALPHA Units S/N 2791957 & above. Also for 165 (6 cyl.) S/N 2763442 & above.</p>	 <p>18-2254 PROP SHAFT Replaces: 44-850308 For: Gen II S/N L100040 & UP</p>																																																								
 <p>18-2167 AP# 1803 DRIVE SHAFT Replaces: 45-41939A1 For all #1 units S/N 2791957 & above except MR/ALPHA Units or units which have been retro-fitted with MR/ALPHA lower units. Also for 165 (6 cyl.) S/N 2763442 & above.</p>	 <p>18-2180 AP# 1846 DRIVE SHAFT Replaces: 45-42634 For all MR/ALPHA Units & older units which have been retro-fitted with MR/ALPHA lower units.</p>																																																								
 <p>18-2261 AP# 2739 ALPHA SHAFT Replaces: 45-816919 All Alpha I Generation II Drives (with new style 18-3056/AP# 1814 Impeller) Serial# D494569 & above.</p>	 <p>18-2346 AP# 2698 BEARING RACE RETAINER Replaces: 824519 For: MR Alpha & Gen II</p>	 <p>18-3719 AP# 2678 PINION NUT Replaces: 11-35921</p>	 <p>18-2359 DRIVE SHAFT NUT SET Replaces: 12-92721 & 11-35921 Contains: 18-3719 Pinion Nut 18-2343 Pinion Nut Washer</p>																																																						
 <p>18-2286 AP# 2416 Replaces: 19755A2</p>  <p>18-2196 Replaces: 19755A4</p> <p>SHIFT SPOOL ASSEMBLY</p>	<table border="1"> <thead> <tr> <th colspan="3">SHIFT SPOOL ASSEMBLY APPLICATION</th> </tr> <tr> <th>Model</th> <th>Serial #</th> <th>Sierra #</th> </tr> </thead> <tbody> <tr><td>1A (EZ-Shift)</td><td>1776349 & UP</td><td>18-2196</td></tr> <tr><td>1B (EZ-Shift)</td><td>1775193 & UP</td><td>18-2196</td></tr> <tr><td>1C (EZ-Shift)</td><td>1777799 & UP</td><td>18-2196</td></tr> <tr><td>120/140</td><td>2062141-3780849</td><td>18-2196</td></tr> <tr><td>120/140</td><td>3780850 & UP</td><td>18-2286</td></tr> <tr><td>160</td><td>2065190-2763441</td><td>18-2196</td></tr> <tr><td>165</td><td>2763442-3780849</td><td>18-2196</td></tr> <tr><td>165</td><td>3780850 & UP</td><td>18-2286</td></tr> <tr><td>888</td><td>3106717-3784374</td><td>18-2196</td></tr> <tr><td>888</td><td>3784375 & UP</td><td>18-2286</td></tr> <tr><td>898/228</td><td>4782330 & UP</td><td>18-2286</td></tr> <tr><td>225-S</td><td>3856268-4200499</td><td>18-2286</td></tr> <tr><td>233</td><td>4200500 & UP</td><td>18-2286</td></tr> <tr><td>470/485</td><td>4208730 & UP</td><td>18-2286</td></tr> <tr><td>R/MR/Alpha One</td><td>6225377 & UP</td><td>18-2286</td></tr> <tr><td>Alpha One (Gen II)</td><td>D494569 & UP</td><td>18-2286</td></tr> </tbody> </table>			SHIFT SPOOL ASSEMBLY APPLICATION			Model	Serial #	Sierra #	1A (EZ-Shift)	1776349 & UP	18-2196	1B (EZ-Shift)	1775193 & UP	18-2196	1C (EZ-Shift)	1777799 & UP	18-2196	120/140	2062141-3780849	18-2196	120/140	3780850 & UP	18-2286	160	2065190-2763441	18-2196	165	2763442-3780849	18-2196	165	3780850 & UP	18-2286	888	3106717-3784374	18-2196	888	3784375 & UP	18-2286	898/228	4782330 & UP	18-2286	225-S	3856268-4200499	18-2286	233	4200500 & UP	18-2286	470/485	4208730 & UP	18-2286	R/MR/Alpha One	6225377 & UP	18-2286	Alpha One (Gen II)	D494569 & UP	18-2286
SHIFT SPOOL ASSEMBLY APPLICATION																																																									
Model	Serial #	Sierra #																																																							
1A (EZ-Shift)	1776349 & UP	18-2196																																																							
1B (EZ-Shift)	1775193 & UP	18-2196																																																							
1C (EZ-Shift)	1777799 & UP	18-2196																																																							
120/140	2062141-3780849	18-2196																																																							
120/140	3780850 & UP	18-2286																																																							
160	2065190-2763441	18-2196																																																							
165	2763442-3780849	18-2196																																																							
165	3780850 & UP	18-2286																																																							
888	3106717-3784374	18-2196																																																							
888	3784375 & UP	18-2286																																																							
898/228	4782330 & UP	18-2286																																																							
225-S	3856268-4200499	18-2286																																																							
233	4200500 & UP	18-2286																																																							
470/485	4208730 & UP	18-2286																																																							
R/MR/Alpha One	6225377 & UP	18-2286																																																							
Alpha One (Gen II)	D494569 & UP	18-2286																																																							

1/0

 <p>18-3759 AP# 2694 BEARING THRUST RING Replaces: 35915</p>	 <p>18-2342 THRUST RING REVERSE GEAR For: MR/ ALPHA</p>	 <p>18-2191 AP# 2178 BEARING CARRIER ASSEMBLY Replaces: 73020A-14 For: #1R/MR/Alpha For: Housings with casting #73020C</p>		
 <p>18-2376 AP# 2635 BEARING CARRIER ASSEMBLY Replaces: 818763A10 For: Alpha Gen II & MR Units For: Housings with casting #73020C1</p>	 <p>18-2150 AP# 505 STAINLESS STEEL SHIFT SHAFT Replaces: 77481-1</p>	 <p>18-2353 AP# 3742 SHIFT ROD BUSHING ASSEMBLY Replaces: 23-815921A21</p>		
 <p>18-2154 AP# 513 SHIFT BUSHING Replaces: 23-30617A2 Mercruiser & Alpha 1 (S/N 1684188 & UP)</p>	 <p>18-3198 AP# 2685 WATER PICK-UP INSERT Port Replaces: 93424-1 For: MR Alpha</p>	 <p>18-3199 AP# 2684 WATER PICK-UP INSERT Starboard Replaces: 93423-1 For: MR Alpha</p>		
 <p>18-2320 AP# 2642 SHIFT SHAFT Replaces: 815919A1 For: Gen II</p>	 <p>18-2130 AP# 2630 SHIFT CRANK Replaces: 76865 For All #1 Units R/MR/Alpha</p>	<p>PKG. OF 2</p>  <p>18-4295 AP# 13276 E-CLIP Replaces: 53-29641 For: Gen II</p>	 <p>18-2299 AP# 2179 TAB WASHER Replaces: 14-79447</p>	 <p>18-2298 AP# 2634 TAB WASHER Replaces: 14-18323</p>
 <p>18-3751 AP# 1117 SPANNER NUT Replaces: 79448</p>	 <p>18-2354 AP# 2638 SEAL CARRIER Replaces: 821759A4</p>	 <p>18-2707 AP# 2383 THRUST COLLAR KEEPER Replaces: 97351 For: Bravo</p>		



Sierra
Marine Engine and Drive Parts
A Division of Teleflex Marine

Bearings & Bearing Kits

Features...

- ★ Our bearings are the highest quality bearings to insure the integrity of your repair.
- ★ Available in convenient kits.
- ★ There are many bearings on the market today. The quality of the materials used and the tolerances in the manufacturing processes can have a dramatic effect on the life expectancy of the bearings.



<p>NEW</p>  <p>18-1120 PINION BEARING Replaces: 31-35246 For: Lower drive shaft III, TR & Bravo II</p>	<p>NEW</p>  <p>18-1123 PINION BEARING Replaces: 31-86754T For: Lower drive shaft Bravo I, II, III</p>	 <p>18-1117 AP# 2762 PINION BEARING Replaces: 31-42647A1</p>													
 <p>18-1356 AP# 13029 PINION BEARING Replaces: 31-54928</p> <table border="1"> <thead> <tr> <th>Model</th> <th>Year</th> <th>Model</th> <th>Year</th> </tr> </thead> <tbody> <tr> <td>215 E/H</td> <td>1970-72</td> <td>II, TR</td> <td>1973-76</td> </tr> <tr> <td>225TRS, 280 TRS</td> <td>1973-76</td> <td>TR, TRS</td> <td>1977-93</td> </tr> </tbody> </table>	Model	Year	Model	Year	215 E/H	1970-72	II, TR	1973-76	225TRS, 280 TRS	1973-76	TR, TRS	1977-93	 <p>18-1142 UPPER PINION BEARING Replaces: 31-32573A1</p>	<p>NEW</p>  <p>18-1098 TAPERED ROLLER BEARING Replaces: 31-86748A1 For: Driveshaft-Bravo I, II, III 250/275 & 3.4L outboards</p>	 <p>18-1143 AP# 13029 TAPERED ROLLER BEARING Replaces: 31-36387A1</p>
Model	Year	Model	Year												
215 E/H	1970-72	II, TR	1973-76												
225TRS, 280 TRS	1973-76	TR, TRS	1977-93												
 <p>18-1156 TAPERED ROLLER BEARING Replaces: 31-30894A1</p>	 <p>18-1159 AP# 570 TAPERED ROLLER BEARING Replaces: 31-35928A1</p>	 <p>18-1161 AP# 1901 TAPERED ROLLER BEARING Replaces: 31-35990A1</p>	 <p>18-1162 AP# 1902 TAPERED ROLLER BEARING Replaces: 31-38356A1</p>												

 <p>18-1163 AP# 1903 TAPERED ROLLER BEARING Replaces: 31-48941A1</p>	 <p>18-1164 AP# 1904 TAPERED ROLLER BEARING Replaces: 31-53079A1</p>	 <p>18-1165 AP# 572 TAPERED ROLLER BEARING Replaces: 31-61100A1</p>	 <p>18-1173 TAPERED ROLLER BEARING Replaces: 31-828437A2</p>
 <p>18-1179 AP# 13036 TAPERED ROLLER BEARING Replaces: 31-32575A1, T1 For: Gen II F680000 & UP</p>	 <p>18-1126 TAPERED ROLLER BEARING Replaces: 31-54036A1 For: Bravo II - Lower (S/N B664190 & UP)</p>	 <p>18-1127 TAPERED ROLLER BEARING Replaces: 31-54038A1 For: Bravo II - Lower (S/N B664190 & UP)</p>	 <p>18-1125 THRUST BEARING Replaces: 31-86771 For: Bravo I, II, III-upper gear case</p>
 <p>18-1128 REVERSE GEAR BEARING Replaces: 31-805182A1 For: Bravo III - Lower (S/N B664190-F729999)</p>	 <p>18-1114 REVERSE GEAR BEARING Replaces: 31-15844 For: Gen II (c/r)</p>	 <p>18-1111 AP# 1905 REVERSE GEAR BEARING SET Replaces: 31-62799A1 For: TR/TRS (RH) (S/M 337316 & UP)</p>	 <p>18-1130 FORWARD GEAR BEARING Replaces: 31-86752A1 For: Bravo I, III - Lower (S/N B664190 & UP)</p>
 <p>18-1129 UPPER DRIVE SHAFT BEARING Replaces: 31-86748A1 For: Bravo I, II, III - Lower (S/N B664190 & UP)</p>	 <p>18-1180 NEEDLE BEARING Replaces: 31-54042T For: Bravo I, II, III, TRS-carrier</p>	 <p>18-1183 NEEDLE BEARING Replaces: 31-87156 For: Upper gearcase driveshaft Bravo I, II, III</p>	 <p>18-1150 AP# 13030 NEEDLE ROLLER BEARING Replaces: 31-92366A1</p>
 <p>18-1157 AP# 2125 NEEDLE ROLLER BEARING Replaces: 31-30895, 31-30895T</p>	 <p>18-1158 AP# 2126 NEEDLE ROLLER BEARING Replaces: 31-30956,T</p>	 <p>18-1153 BALL BEARING Replaces: 30-63326, 30-63326T</p>	

MERCUISER

Drive System



 <p>18-1155 AP# 1900 BALL BEARING Replaces: 30-88957A1, T</p>	 <p>18-1160 AP# 571 BEARING KIT Replaces: 31-35988A2, 31-35988A12</p>	 <p>18-1103 BEARING SET Replaces: 31-66668A1, 31-99328A1 For: Bravo I, II, III - Lower (S/N B664190 & UP)</p>
---	--	--

MERCUISER STERNDRIVE UPPER GEAR HOUSING BEARINGS

Sterndrive Model	Drive Ratio	Years	Serial Number	Drive Gear (Yoke)	Driven Gear	Upper Cap
IA,IB,IC & EZ Shift	All	1964-66	1684188 - 2065186	18-1160	18-1161	18-1179
120/140	1.98	1967	2062141- 2187468	18-1160	18-1161	18-1161
120/140	1.98	1967-71	2187469 - 3134193	18-1160	18-1161	18-1179
120/140	1.98	1971-82	3134194 - 6225576	18-1160	18-1161	18-1165
470/485	1.84	1976-82	4208730 - 6225576	18-1160	18-1161	18-1165
160	1.68	1967	2065190 - 2182197	18-1160	18-1161	18-1161
160	1.68	1967-71	2182198 - 3134193	18-1160	18-1161	18-1179
165	1.65	1971-81	3213658 - UP	18-1160	18-1161	18-1165
888	1.5	1971-73	3106717 - 3134193	18-1160	18-1161	—
888	1.5	1973-77	3134194 - UP	18-1160	18-1161	18-1165
225-S	1.5	1974	3856268 - 4200499	18-1160	18-1161	18-1165
898/228	1.65	1977-82	4782330 - 6225576	18-1160	18-1161	18-1165
233	1.32	1975-77	4200500 - UP	—	—	18-1165
250	1.32	1977	4791300 - 4898729	—	—	18-1165
255-TRS	All	1973-74	3377316 - 4203749	18-1162 ③	18-1162	—
260	1.5	1978-82	4898730 - 6225576	18-1160	18-1161	18-1165
280-TRS	All	1975-76	4203750 - 4895399	18-1162 ③	18-1162	—
R/MR/Alpha One	1.98/1.84/ 1.65/1.50	1984-90	6225577 - UP	18-1160	18-1161 ① ④	18-1165
R/MR/Alpha One	1.5	1984-90	6225577 - UP	18-1160	18-1142	18-1165
R/MR/Alpha One	1.32	1984-90	6225577 - UP	—	—	18-1165
R/MR/Alpha One	1.5 Heavy Duty	1984-90	6225577 - UP	—	18-1142	18-1165
Alpha One SS	1.32	1986-89	A545004 - UP	—	—	18-1165
Alpha One SS	1.5	1986-89	A545004 - UP	—	18-1142	18-1165
Alpha One Gen II	2.40/1.98/ 1.81/1.65	1991-95	D469859 - F679999	18-1160	18-1161 ④	18-1165
Alpha One Gen II	1.5	1991-95	D469859 - F679999	18-1160	18-1142	18-1165
Alpha One Gen II	2.40/1.94/ 1.81/1.62	1996-97	F680000 - K999999	18-1160	18-1161 ④	18-1179
Alpha One Gen II	1.47	1996-97	F680000 - K999999	18-1160	18-1142	18-1179
Alpha One Gen II	2.40/2.00/ 1.94/1.81/ 1.62	1998 & Up	L100040 - UP	—	18-1161	18-1179
Alpha One Gen II	1.47	1998 & Up	L100040 - UP	—	18-1142	18-1179
II-TR	—	1973-76	3377316 - 4794899	18-1162 ②	18-1162	—
SSM II	—	1982-97	ALL	18-1162 ③	18-1162	—
TR/TRS	—	1977-93	4794900 - UP	18-1162 ③	18-1162	—
Bravo I, II, III	All	—	B664190 & UP	—	—	18-1129

① Timken Cone # 89449 / Cup 89410

② Straight Shoulder Gear Only

③ Bearing for U-Joint Yoke

④ Use 18-1142 for 1.5:1 Upper Gear Ratio



MERCUISER Drive System

MERCUISER STERNDRIVE LOWER GEAR HOUSING BEARINGS								
Sterndrive Model	Years	Beg. S/N - End. S/N	Prop Bearing Carrier	Lower Drive Shaft (Pinion)	Upper Drive Shaft	Inside Forward Gear (Needle)	Outside Forward Gear	Reverse Gear
60	1965-66	1830753 - 206740	—	—	—	—	18-1162	—
80/90	1966-72	2063741 - 3225967	18-1158	—	—	18-1157	18-1156	—
I	1963	1534570 - 1536617	18-1158	—	18-1153	18-1157	18-1156	—
I	1963	1536618 - 1684187	18-1158	—	—	18-1157	18-1156	—
IA, IB, IC & EZ Shift	1964-66	1684188 - 2065189	18-1158	—	—	18-1157	18-1159	18-1155
120/140	1967-69	2062141 - 2791956	18-1158	—	18-1164 ④	18-1157	18-1159	18-1155
120/140	1970-77	2791957 - 4893634	18-1158	—	18-1164	18-1157	18-1159	18-1155
120/140	1978-82	4893635 - 6225576	18-1158	18-1150	18-1164	18-1157	18-1159	18-1155
470	1976-77	4208730 - 4893934	18-1158	—	18-1164	18-1157	18-1159	18-1155
470/485	1978-82	4893835 - 6225576	18-1158	18-1150	18-1164	18-1157	18-1159	18-1155
160	1967-69	2065190 - 2763441	18-1158	—	18-1164 ④	18-1157	18-1159	18-1155
165	1970-77	2763442 - 4890459	18-1158	—	18-1164	18-1157	18-1159	18-1155
165	1978-81	4890460 - UP	18-1158	18-1150	18-1164	18-1157	18-1159	18-1155
888	1971-77	3106717 - UP	18-1158	—	18-1164	18-1157	18-1159	18-1155
225/233	1974-77	3856268 - UP	18-1158	—	18-1164	18-1157	18-1159	18-1155
898/228	1977	4782330 - 4898729	18-1158	—	18-1164	18-1157	18-1159	18-1155
898/228	1978-82	4898730 - 6225576	18-1158	18-1150	18-1164	18-1157	18-1159	18-1155
250	1977	4791300 - 4898729	18-1158	—	18-1164	18-1157	18-1159	18-1155
255-TRS	1973-74	3377316 - 4203749	18-1158	—	—	—	18-1159	N/A
260	1978-82	4898730 - 6225576	18-1158	18-1150	18-1164	18-1157	18-1159	18-1155
280-TRS	1975-76	4203750 - 4895399	18-1158	—	—	—	18-1159	N/A
R	1983	6225577 - UP	18-1158	18-1150	18-1164	18-1157	18-1159	18-1155
MR / Alpha One	1984-90	6225577 - UP	18-1158	18-1117	18-1143	—	18-1159 ⑤	18-1155
MR / Alpha One	1984-90	6225577 - UP	18-1158	18-1117	18-1143	18-1157 ②	18-1159 ⑤	18-1155
MR / Alpha One (CR)	1984-90	6225577 - UP	18-1158	18-1117	18-1143	—	—	—
Alpha One SS	1986-89	A545004 - UP	18-1158	18-1117	18-1143	18-1157	18-1159	18-1155
Alpha One Gen II	1991-95	D469859 - F679999	18-1158	18-1117	18-1143	18-1157	18-1159 ⑤	18-1155
Alpha One Gen II (CR)	1991-95	D469859 - F679999	18-1158	18-1117	18-1143	—	—	—
Alpha One Gen II	1996-97	F680000 - K999999	18-1158	18-1117	18-1143	18-1157	18-1156	18-1155
Alpha One Gen II (CR)	1996-97	F680000 - K999999	18-1158	18-1117	18-1143	—	—	—
Alpha One Gen II	1998-newer	L100040 - UP	18-1158	18-1117	18-1143	18-1157	18-1156 ③	18-1155
Alpha One Gen II (CR)	1998-newer	L100040 - UP	18-1158	18-1117	18-1143	—	—	—
II	1962-67	1474909 - 2275488	—	—	—	N/A	18-1156 ③	N/A
II	1968-69	2398798 - 2671321	—	—	—	—	18-1162	18-1156 ③
II-TR	1973-76	3377316 - 4794899	—	—	18-1161 ①	—	—	N/A
TR	1973-93	4794900 - UP	—	—	18-1161 ①	—	—	N/A
TRS	1973-93	4794900 - UP	18-1158	—	—	—	18-1159	N/A

① 18-1161 Top Bearing /
18-1163 Bottom Bearing

② Torrington#B1616
③ Prop Shaft Drive Gear

④ #15520 Stamped on Cup
⑤ Use 18-1173 for 2.40:1 ratio only (new style lower gears) our **18-2206**

MERCUISER

Drive System



18-8207
SEAL & BEARING KIT
Replaces: 43-803068T1
For: "R" drive

— CONTAINS —

Sierra#	Description	O.E.#	Qty.
18-2652	Lower Gear Housing Seal Kit	26-33144A2	1
18-1155	Ball Bearing	30-88957A1	1
18-2285	Shim	15-47397A1	1
18-1158	Needle Roller Bearing	31-30956	1
18-2299	Tab Washer	14-79447	1
18-2297	Shim	15-97166	1
18-1150	Needle Roller Bearing	31-92366A1	1
18-1164	Tapered Roller Bearing	31-53079A1	1
18-1159	Tapered Roller Bearing	31-35928A1	1



18-8208
SEAL & BEARING KIT
Replaces: 31-803090T1
For: MR/Alpha Drive

— CONTAINS —

Sierra#	Description	O.E.#	Qty.
18-2652	Lower Gear Housing Seal Kit	26-33144A2	1
18-1155	Ball Bearing	30-88957A1	1
18-1117	Pinion Bearing	31-42647A1	1
18-1143	Tapered Roller Bearing	31-36387A1	1
18-3719	Pinion Nut	11-35921	1
18-2299	Tab Washer	14-79447	1
18-2298	Tab Washer	14-18323	1
18-1158	Needle Roller Bearing	31-30956	1
18-1159	Tapered Roller Bearing	31-35928A1	1
18-2285	Shim Kit	15-47397A1	1
18-1157	Needle Roller Bearing	31-30895	1
18-2343	Washer	12-982721	1
18-2294	Shim Kit	2470	1



— CONTAINS —

Sierra#	Description	O.E.#	Qty.
18-2646-1	Upper Gear Housing Seal Kit	26-816575A3	1
18-1155	Ball Bearing	30-88957A1	1
18-1159	Tapered Roller Bearing	31-35928A1	1
18-1173	Tapered Roller Bearing	31-828437A2	1
18-1143	Tapered Roller Bearing	31-36387A1	1
18-1157	Needle Roller Bearing	31-30895	1
18-1158	Needle Roller Bearing	31-30956	1
18-1117	Pinion Bearing	31-42647A1	1
18-2343	Washer	12-982721	1
18-3719	Pinion Nut	11-35921	1
18-2298	Tab Washer	14-18323	1
18-2285	Shim Kit	15-47397A1	1
18-2294	Shim Kit	2470	1



18-8209
SEAL & BEARING KIT
Replaces: 31-803094T1
For: Gen II drives

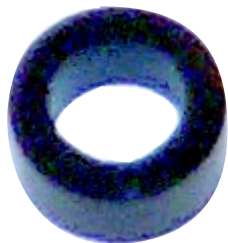













18-2349
AP# 2349
SLEEVE
Replaces: 23-67370



18-2244
AP# 2686
DRAIN PLUG
Replaces: 10-79953A2
For: #1/R/MR/Alpha/Alpha I Gen II
Both Upper And Lower Units



18-2375
AP# 2683
DRAIN PLUG
Replaces: 10-14834A1, 22-67892A1
(Magnet)
For: #1/R/MR/Alpha/Alpha I Gen II
Lower Units

 <p>18-2164 AP# 1382 CONTROL BOX SHIFT LEVER Replaces: 34682</p>	 <p>18-2165 AP# 1383 CONTROL BOX CAM Replaces: 59369</p>	 <p>18-2281 THRUST WASHER Replaces: 23-824108 Fits: MR/Alpha & GenII</p>	 <p>18-4220 AP# 1192 THRUST WASHER Replaces: 13171, 77987 V-6, Outboards & Mercruiser Sterndrives</p>																
 <p>18-5234 AP# 1384 THRUST WASHER Replaces: 65091T</p>	 <p>18-3701 AP# 122 PROPELLER NUT KIT Replaces: 11-52707A1 —CONTAINS—</p> <table border="1" style="width:100%; border-collapse: collapse;"> <thead> <tr> <th>Sierra#</th> <th>AP #</th> <th>O.E.#</th> <th>Description</th> </tr> </thead> <tbody> <tr> <td>18-3200</td> <td>2708</td> <td>14-31210, 14-816629</td> <td>Tab Washer</td> </tr> <tr> <td>18-3700</td> <td>—</td> <td>11-52707</td> <td>Prop Nut</td> </tr> </tbody> </table>	Sierra#	AP #	O.E.#	Description	18-3200	2708	14-31210, 14-816629	Tab Washer	18-3700	—	11-52707	Prop Nut	<p>PKG. OF 10</p>  <p>18-3200 AP# 2708 TAB WASHER Replaces: 14-31210, 14-816629</p>					
Sierra#	AP #	O.E.#	Description																
18-3200	2708	14-31210, 14-816629	Tab Washer																
18-3700	—	11-52707	Prop Nut																
 <p>18-3700 PROP NUT Replaces: 11-52707</p>	 <p>18-3714 AP# 268 BRASS CASTLE WASHER Replaces: 12-31211A2</p>	 <p>18-4444 AP# 4298 PROPELLER WRENCH Replaces: 91-95830A1</p>																	
 <p>18-4459 PROPELLER WRENCH Replaces: 91-821887A-1, 91-859046Q4</p>		 <p>18-4446 PROPELLER WRENCH KIT —CONTAINS—</p> <table border="1" style="width:100%; border-collapse: collapse;"> <thead> <tr> <th>Sierra#</th> <th>AP #</th> <th>O.E.#</th> <th>Description</th> </tr> </thead> <tbody> <tr> <td>18-3200</td> <td>2708</td> <td>14-31210, 14-816629</td> <td>Tab Washer</td> </tr> <tr> <td>18-3700</td> <td>—</td> <td>11-52707</td> <td>Prop Nut</td> </tr> <tr> <td>18-4444</td> <td>4298</td> <td>91-95830A1</td> <td>Prop Wrench</td> </tr> </tbody> </table>		Sierra#	AP #	O.E.#	Description	18-3200	2708	14-31210, 14-816629	Tab Washer	18-3700	—	11-52707	Prop Nut	18-4444	4298	91-95830A1	Prop Wrench
Sierra#	AP #	O.E.#	Description																
18-3200	2708	14-31210, 14-816629	Tab Washer																
18-3700	—	11-52707	Prop Nut																
18-4444	4298	91-95830A1	Prop Wrench																







MERCUISER

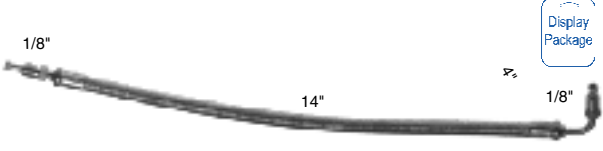
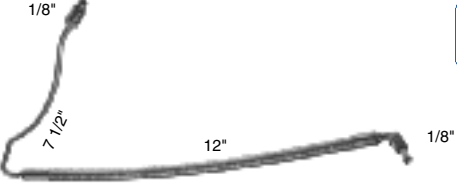

Features...

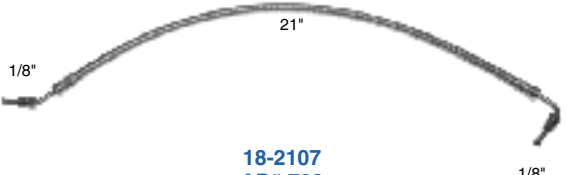
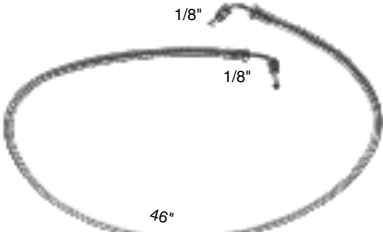
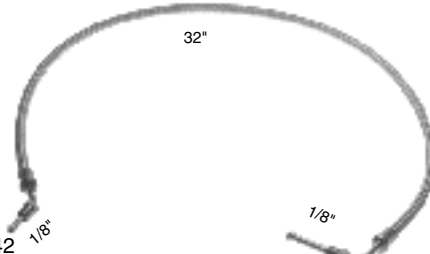
- ★ Marine grade stainless steel fittings and tubing.
- ★ Working pressure up to 3000 PSI.
- ★ Precision made for exact fit.
- ★ Meets or exceeds OEM specifications.
- ★ Best coverage in the industry

 <p>1/8" 14" 1/8"</p> <p>18-2103 AP# 706 CONNECTOR TO TRIM CYLINDER Replaces: 32-86036, 32-86036Q</p>	 <p>1/8" 7 1/2" 12" 1/8"</p> <p>18-2105 AP# 711 GIMBAL HOUSING TO STARBOARD TILT CYLINDER Replaces: 32-45973</p>																								
 <p>1/8" 11 3/4" 1/8"</p> <p>18-2106 AP# 712 GIMBAL HOUSING TO PORT TILT CYLINDER Replaces: 32-45974</p>	 <p>1/8" 21" 1/8"</p> <p>18-2107 AP# 703 CONNECTOR TO HYDRAULIC PUMP Replaces: 32-55816</p>																								
 <p>1/8" 1/8" 46"</p> <p>18-2108 AP# 704 CONNECTOR TO HYDRAULIC PUMP Replaces: 32-59841</p>	 <p>32" 1/8" 1/8"</p> <p>18-2109 AP# 702 CONNECTOR TO VALVE Replaces: 32-59842</p>																								
 <p>1/8" 11 1/2" 14" 1/8"</p> <p>(STARBOARD) TRIM HOSE Connector to bottom of trim cylinder MCM 120-260 & BRAVO</p>	 <p>1/8" 11 1/2" 14" 1/8"</p> <p>(PORT) TRIM HOSE Connector to bottom of trim cylinder MCM 120-260 & BRAVO</p>																								
<table border="1"> <thead> <tr> <th>Sierra #</th> <th>AP #</th> <th>O.E. #</th> <th>Description</th> </tr> </thead> <tbody> <tr> <td>18-2114</td> <td>1804</td> <td>32-99902-1</td> <td>Trim Cyl. Casting #14034-1</td> </tr> <tr> <td>18-2136*</td> <td>698</td> <td>32-99902</td> <td>Trim Cyl. Casting #98704, 98704-1</td> </tr> </tbody> </table> <p>* Approximately 11 1/4" long</p>	Sierra #	AP #	O.E. #	Description	18-2114	1804	32-99902-1	Trim Cyl. Casting #14034-1	18-2136*	698	32-99902	Trim Cyl. Casting #98704, 98704-1	<table border="1"> <thead> <tr> <th>Sierra #</th> <th>AP #</th> <th>O.E. #</th> <th>Description</th> </tr> </thead> <tbody> <tr> <td>18-2115</td> <td>1805</td> <td>32-99903-1</td> <td>Trim Cyl. Casting #14035-1</td> </tr> <tr> <td>18-2137*</td> <td>699</td> <td>32-99903</td> <td>Trim Cyl. Casting #98703, 98703-1</td> </tr> </tbody> </table> <p>* Approximately 11 1/4" long</p>	Sierra #	AP #	O.E. #	Description	18-2115	1805	32-99903-1	Trim Cyl. Casting #14035-1	18-2137*	699	32-99903	Trim Cyl. Casting #98703, 98703-1
Sierra #	AP #	O.E. #	Description																						
18-2114	1804	32-99902-1	Trim Cyl. Casting #14034-1																						
18-2136*	698	32-99902	Trim Cyl. Casting #98704, 98704-1																						
Sierra #	AP #	O.E. #	Description																						
18-2115	1805	32-99903-1	Trim Cyl. Casting #14035-1																						
18-2137*	699	32-99903	Trim Cyl. Casting #98703, 98703-1																						







APPLICATION ON NEXT PAGE

POWER TRIM HOSE APPLICATION

Stern Drive Model	Years	Serial No.	Trim Cylinder to Connector (port down)	Trim Cylinder to Connector (port up)	Trim Cylinder to Connector (stbd down)	Trim Cylinder to Connector (stbd up)	Pump to Hydraulic Connector	Connector to Hydraulic Connector	Connector to Reverse Lock Valve	Hydraulic Pump & Reverse Lock Valve
120, 140	1967-69	2062141 - 2791956	18-2119	18-2106	18-2120	18-2105	—	N/A	—	18-2126
120, 140	1970-73	2791957 - 3780849	18-2103	18-2103	18-2103	18-2103	18-2107	N/A	—	18-2126
120, 140	1974-82	4893635 - 6225576	18-2103	18-2103	18-2103	18-2103	18-2107	N/A	18-2109	18-2126
470/485	1976-82	4208730 - 6225576	18-2103	18-2103	18-2103	18-2103	18-2107	N/A	18-2109	18-2126
160	1967-69	2065190 - 2763441	18-2119	18-2106	18-2120	18-2105	—	N/A	—	18-2126
165	1970-73	2763442 - 3780849	18-2103	18-2103	18-2103	18-2103	18-2107	N/A	—	18-2126
165	1974-81	3780850 & UP	18-2103	18-2103	18-2103	18-2103	18-2107	N/A	18-2109	18-2126
888	1974-newer	3106717 & UP	18-2103	18-2103	18-2103	18-2103	18-2108	N/A	18-2109	—
225/233	1974-77	3856268 & UP	18-2103	18-2103	18-2103	18-2103	18-2108	N/A	18-2109	—
228/898/250/260	1977-82	4782330 - 6225576	18-2103	18-2103	18-2103	18-2103	18-2108	N/A	18-2109	—
R/MR/Alpha/SS	1983-90	6225577 & UP	18-2137 ③	18-2116	18-2136 ③	18-2116	18-2123	18-2124	N/A	N/A
R/MR/Alpha/SS	1983-90	6225577 & UP	18-2115A	18-2116	18-2114 ④	18-2116	18-2123	18-2124	N/A	N/A
Alpha One GEN II	1991-97	D469859 & UP	18-2115	18-2116	18-2114	18-2116	18-2123	18-2124	N/A	N/A
Alpha One GEN II	1998 & UP	0L100040 & UP	18-2115	18-2116	18-2114	18-2435	18-2436	N/A	N/A	N/A
Bravo I,II,III & Blackhawk	1988-95	B664190 & UP	18-2137	18-2116	18-2136	18-2116	18-2123	18-2124	N/A	N/A
II (1.78)	1968-69	2398798 - 2671321	18-2103	18-2103	18-2103	18-2103	—	N/A	—	18-2126
III	1968-72	2373127 - 3002613	18-2103	18-2103	18-2103	18-2103	—	N/A	—	—
215E/H	1970-72	2909035 - 2915034	18-2103	18-2103	18-2103	18-2103	—	N/A	—	—
TR/TRS	1973-93	3377316 & Up	18-2103 ②	18-2103	18-2103 ②	18-2103	—	N/A	—	—
TR/TRS	1973-93	3377316 & Up	18-2103 ②	18-2103	18-2103 ②	18-2103	—	N/A	—	—
TR/TRS	1973-93	3377316 & Up	— ①	18-2103	— ①	18-2103	—	N/A	—	—

- ① 90° hose end
- ② External trim lines

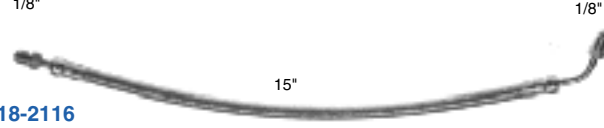
- ③ Internal cylinder lines
- ④ Oildyne pump

 <p>18-2112 AP# 713 CONNECTOR TO PORT TRIM CYLINDER Replaces: 32-87234</p>	 <p>18-2113 AP# 714 CONNECTOR TO STARBOARD TRIM CYLINDER Replaces: 32-87235</p>
 <p>18-2435 POWER TRIM HOSE Replaces: 32-861127 Pump to connector block - Gen II - trim system (S/N L100400 - UP)</p>	 <p>18-2436 POWER TRIM HOSE Replaces: 32-861128 Pump to connector block - Gen II - trim system (S/N L100400 - UP)</p>
 <p>18-2116 AP# 700 TRIM CYLINDER TO CONNECTOR Replaces: 32-99904</p>	 <p>18-2119 AP# 692 GIMBAL HOUSING TO PORT TRIM Replaces: 32-45703</p>

MERCUISER Drive System



18-2120
AP# 693
GIMBAL HOUSING TO STARBOARD TRIM
Replaces: 32-69871

18-2123
AP# 13047
TRIM HOSE
Connector to hydraulic pump
Replaces: 32-95858, 32-861127
(O.E. color black)

18-2124
AP# 13048
TRIM HOSE
Connector to hydraulic pump
Replaces: 32-95859
(O.E. color gray)

18-2126
AP# 13049
HYDRAULIC PUMP TO REVERSE LOCK VALVE
Replaces: 32-52951A1

- ★ High quality EPDM rubber cups
- ★ Metal hose connector complete with rubber washer
- ★ Use with a standard garden hose
- ★ Corrosion resistant dicromate finish
- ★ Installs in seconds
- ★ No tools required

18-9010
HEAVY DUTY MOTOR FLUSHER
Replaces: 73971A2, 44357A2

Flushes cooling system of salts and sediments and allows engine to idle for tuning and engine adjustment in your own driveway. Simply slip attachment over the engine's side water intakes. Coated spring steel arms clamp suction cup securely over the engine's side water intakes.

STAINLESS STEEL LOCKNUTS

Sierra #	AP #	O.E. #	Thread Size
18-3720	117	11-34932	3/8" - 24
18-3721 ①	—	11-34933	7/16" - 20
18-3722 ②	119	11-35888, 11-20361	1/4" - 28
18-3723	120	11-45592	5/16" - 24

① PKG OF 6 ② PKG OF 5

1/0

PKG OF 2

18-9099
AP# 1445
TRAILERING CLIPS
Replaces: 817019A1, 817019Q2
For all ALPHA I, ALPHA Generation II, Bravo I, II, III, and Blackhawk

18-2372
AP# 2637
TRIM CYLINDER END CAP
Replaces: 88035
1.850 Cap Diameter
For: R/MR/Alpha

18-2373
AP# 2636
TRIM CYLINDER END CAP
Replaces: 806191T
1.890 Cap Diameter
For: R/MR/Alpha/ Gen II/Bravo

MERCUISER



Features...

- ★ Long lasting high gloss finish.
- ★ Excellent corrosion resistance.
- ★ Extensive testing for safety and durability.
- ★ Manufactured by hydraulic experts.
- ★ Marine grade stainless steel shaft.

 <p>18-2291 AP# 2722 POWER TRIM CYLINDER O-RING KIT Replaces: 25-60342A2 Fits All Stern Drive Models: 120, 140, 160, 165, 888, 898, 228, 225-S, 233, 250, 260,470 & 485</p>	 <p>18-2142 AP# 13053 POWER TRIM CYLINDER Replaces: 45706A14 Fits All Stern Drive Models with internal lines: 120, 140, 160, 165, 888, 898, 228, 225-S, 233, 250, 260,470 & 485</p>	 <p>18-2148 AP# 2660 POWER TRIM CYLINDER HOUSING Replaces: 77442A1 Fits All Stern Drive Models: 120, 140, 160, 165, 888, 898, 228, 225-S, 233, 250, 260,470 & 485</p>	
 <p>18-2420 POWER TRIM CYLINDER Replaces: 14034A3 For: R/MR/ALPHA (Starboard)</p>	 <p>18-2421 POWER TRIM CYLINDER Replaces: 14035A3 For: R/MR/ALPHA (Port)</p>	 <p>18-2422 POWER TRIM CYLINDER Replaces: 815935A7 For: GEN II (Port) (S/N F680000 - UP)</p>	 <p>18-2423 POWER TRIM CYLINDER Replaces: 81595A7 For: GEN II (Starboard) (S/N F680000 - UP)</p>
 <p>18-2424 POWER TRIM CYLINDER Replaces: 98703A26 For: BRAVO (Port)</p>	 <p>18-2425 POWER TRIM CYLINDER Replaces: 98704A17, 98704A26 For: BRAVO (Starboard)</p>	 <p>18-2426 POWER TRIM CYLINDER Replaces: 98703A3 For: R/MR/ALPHA (Port)</p>	 <p>18-2427 POWER TRIM CYLINDER Replaces: 98704A3 For: R/MR/ALPHA (Starboard)</p>

APPLICATION ON NEXT PAGE

MERCUISER

Drive System



 <p>18-2649 AP# 2384 POWER TRIM SEAL KIT Replaces: 25-87400A2</p>	 <p>18-2428 TRIM CYLINDER REPAIR KIT Replaces: 87399A2 For: R/MR/ALPHA I, BRAVO</p>	 <p>18-2429 TRIM CYLINDER REPAIR KIT Replaces: 89399A3 For: ALPHA I, GEN II</p>
---	--	--

POWER TRIM CYLINDER APPLICATION

Model	Year	Serial Number	Trim Cylinder Port	Trim Cylinder Starboard	Housing Port	Housing Starboard	Trim Cylinder Seal Kit
120/ 140 4cyl, 160 6 cyl	1967- 69	2062141- 2791956	18-2142	18-2142	—	—	—
All #1 Drives ①	1970- 82	2791957- 6225576	18-2142	18-2142	18-2148	18-2148	18-2291
R/ MR/ ALPHA I	1983-90	6225577 & UP	18-2426	18-2427	—	—	18-2649
ALPHA I SS	1986- 89	0A545004 & UP	18-2426	18-2427	—	—	18-2649
R/ MR/ ALPHA I	1983-90	6225577 & UP	18-2421	18-2420	—	—	18-2649
ALPHA I SS	1986- 89	0A545004 & UP	18-2421	18-2420	—	—	18-2649
ALPHA I GEN II	1991-2001	0D469859 & UP	18-2422	18-2423	—	—	18-2649
BRAVO II/ III	1988 & UP	0B664190 & UP	18-2424	18-2425	—	—	18-2649
BLACKHAWK	1994-95	0F186717 & UP	18-2424	18-2425	—	—	18-2649





① Excludes the TR, TRS, 215E, H and early II & III drives

③ With 16 3/16" long trim cylinder tube.









② With 15 9/16" long trim cylinder tube.

 <p>18-4252 CONTINUITY SPRING Replaces: 24-46312 Grounds the trim cylinder to the pivot pin shaft.</p>	 <p>18-2151 AP# 507 7 1/2" (Front) Replaces: 17-45738 18-2152 AP# 506 10 1/2" (Rear) Replaces: 17-45735 PIVOT PIN SHAFT Used on 120, 120-260, 140,165, 225S, 233, 250, 470, 888, 898/228 Use 18-2701/AP# 501 Bushing</p>	 <p>18-2393 PIVOT PIN Replaces: 17-14872A1 For: Trim cylinder rear R/MR/Alpha Use: 18-2702-1 AP# 510 Bushing</p>	 <p>18-2394 PIVOT PIN Replaces: 17-14873A1 For: Trim cylinder front R/MR/Alpha Use: 18-2702-1 AP# 510 Bushing</p>
---	--	--	--

 <p>18-2395 PIVOT PIN Replaces: 17-815953 For: Trim cylinder front & rear Gen II</p>	 <p>18-2396 AP# 2647 PIVOT PIN Replaces: 17-44166 For: Rear Bravo</p>	 <p>18-2397 AP# 2648 PIVOT PIN Replaces: 17-44167A1 For: Front Bravo</p>
---	--	--

 <p>18-2701 POWER TRIM BUSHING 18-2701 18-2701-04 AP# 501 Replaces: 23-89574 Fits 120/260 Drive Units (S/N 6225276 & DOWN)</p>	 <p>18-2702-1 POWER TRIM BUSHING 18-2702-1 18-2702-04 AP# 510 Replaces: 23-99291, 23-99291T Fits 120/260 Drive Units (S/N 6225277 & UP)</p>	 <p>18-4288 AP# 553 POWER TRIM BUSHING Replaces: 23-807073 For: Bravo</p>	 <p>18-2345 AP# 13084 PIVOT PIN E-RING Replaces: 53-815949 For: Gen II</p>	 <p>18-4289 AP# 2649 RETAINING RING Replaces: 53-805272 For: Bravo</p>
--	---	---	--	--

1/0

<p>PKG. OF 4</p>  <p>18-2336 AP# 518 POWER TRIM BUSHING Replaces: 23-90203 For: TR, TRS, SSM</p>	<p>PKG. OF 8</p>  <p>18-2341 AP# 13081 POWER TRIM BUSHING Replaces: 23-815950, 23-8159501 For: Gen II</p>	<p>PKG OF 5</p>  <p>18-3232 Housing Plug Replaces: 19-47579 For: MR ALPHA</p>
 <p>18-6011 ①18-6011A AP# 4000 TRIM TAB Replaces: 31640A1, 31640Q4 (Standard — 2 1/4" Long)</p>	 <p>18-6012 ①18-6012A AP# 4001 TRIM TAB Replaces: 34127A1, 34127T2 (4" Long)</p>	 <p>18-6013 ANODE Replaces: 34762A1</p>
 <p>18-6014 ①18-6014A AP# 4004 TRIM TAB (High Performance) Replaces: 46399A1, 822779Q1</p>	<p>PKG OF 2</p>  <p>18-6015 ①18-6015A AP# 4005 ANODE Replaces: 55989A3, Q9, T9 18-60151 AP# 4005B PKG OF 10</p>	 <p>18-6016 ①18-6016 AP# 4006 ANODIC PLATE Replaces: 76214, 76214Q5 18-60161 AP# 4006B PKG OF 10</p>
<p>NEW</p>  <p>18-6093 ①18-6093A AP# 4014 ANODE Replaces: 806105A1, 806105Q1, T1</p>	 <p>18-6066 ①18-6066A ANODE Replaces: 43994A2, 821631Q1 ALPHA I GENERATION II, BRAVO</p>	 <p>18-6067 ①18-6067A AP# 3218 ANODE Replaces: 806189A1, 806189T1, 806189Q1</p>

① New Product - Aluminum

MERCUISER

Drive System



* FOR FRESH WATER USE ONLY			
 <p>18-6089 MAGNESIUM ANODE Replaces: 806190 For: Bravo - trim ram</p>	 <p>18-6099 MAGNESIUM ANODE Replaces: 821629, 821629A1, 821629Q1 For: Alpha I Gen II</p>	 <p>18-6092 ①18-6092A AP# 4080 ANODE Replaces: 806190A1, 806190Q1, T1</p>	
 <p>18-6079 MAGNESIUM ANODE Replaces: 806105 For: Alpha I - bearing carrier</p>	 <p>18-6080 ①18-6080A ANODE Replaces: 821629A1, 821629Q1, T1</p>	 <p>18-6114 MAGNESIUM ANODE Replaces: 806189 For: Alpha I - trim ram</p>	
 <p>18-6068 ANODE Replaces: 826134, 826134Q ALPHA I GENERATION II</p>	 <p>18-6240 MAGNESIUM ANODE Replaces: 821630, 821630Q1, 821630A1 For: Bravo</p>	 <p>18-6094 ①18-6094A ANODE Replaces: 821630A1, Q1, T1</p>	
 <p>18-6241* MAGNESIUM ANODE Replaces: 31640, 31640Q4 For: Standard lower units</p>	 <p>18-6242* MAGNESIUM ANODE Replaces: 55989</p>	 <p>18-6243* MAGNESIUM ANODE Replaces: 43994, 821631Q1</p>	 <p>18-6244* MAGNESIUM ANODE Replaces: 76214, 76214Q5</p>

① New Product - Aluminum



Features...

- ★ *Seals and O-rings designed to provide excellent performance in the harsh marine environment.*
- ★ *Kits include all necessary parts to do a complete reseal.*

— CONTAINS —			
Sierra#	Description	O.E.#	Qty.
18-2599	Face Seal and Tool	26-818575A2	1
18-2564	Water Pump Base To Face Plate Gasket	27-43033-1	1
18-2566	Face Plate to Water Pump Cover Gasket	27-817277	1
18-2945	Sealing Washer	12-19183	1
18-2944	Seal	26-45577	1
18-2002	Oil Seal	26-76868	1
18-2013	Oil Seal	26-16977	1
18-2014	Oil Seal	26-89238	1
18-2054	Oil Seal	26-81646-1	1
18-2076	Oil Seal	26-12224	1
18-2077	Oil Seal	26-14077	1
18-7159	O-Ring	25-31534	1
18-7168	O-Ring	25-48171	2
18-7176	O-Ring	25-90011	1
18-7420	O-Ring	25-21836	2
18-7491	O-Ring	25-36318	2
18-0594	Oil Seal	26-66302	2
18-7413	O-Ring	25-62702	1

— CONTAINS —			
Sierra#	Description	O.E.#	Qty.
18-2516	Bravo Outdrive Seal	16755	1
18-1240	Outdrive Seal	12708	1
18-2945	Gear Housing Drain Screw Gasket	12-19183	1
18-7198	O-Ring	25-45710	1
18-7102	O-Ring	25-62706	1
18-7105	O-Ring	25-62705	1
18-7449	O-Ring	25-97387	1
18-7153	O-Ring	25-25439	2
18-7167	O-Ring	25-97386	1
18-2010	Oil Seal	26-12709	1
18-2715	Spring Kit	24-17997A1	1
18-7117	O-Ring	25-35027	1
18-7169	O-Ring	25-70937	1



18-2646-1
AP# 834
LOWER UNIT SEAL KIT
Replaces: 26-816575A3
For: Alpha Gen II

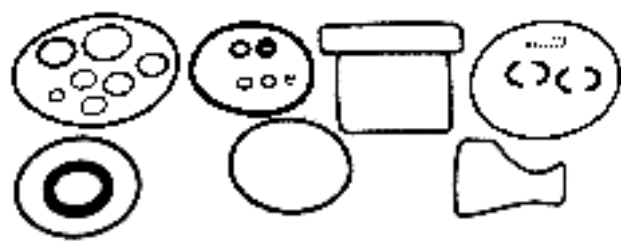

18-2643
AP# 2388
UPPER GEAR CASE SEAL KIT
Replaces: 26-16709A2
BRAVO - BLACKHAWK



MERCUISER

Drive System



— CONTAINS —			
Sierra#	Desc.	O.E.#	Qty.
18-2944	Oil Passage Seal	26-45577	1
18-2945	Gear Housing Drain Screw Gasket	12-19183	2
18-7169	O-Ring	25-70937	1
18-7161	O-Ring	25-32546	1
18-7153	O-Ring	25-25439	2
18-7420	O-Ring	25-21836	2
18-2056	Oil Seal	26-66302	2
18-2003	Oil Seal	26-68493	1
18-2715	Spring Kit	24-17997A1	1



18-2644
AP# 3807
DRIVE SHAFT HOUSING SEAL KIT
Replaces: 26-88397A1
ALPHA I GENERATION II

— CONTAINS —			
Sierra#	Description	O.E.#	Qty.
18-2944	Oil Passage Seal	26-45577	1
18-2945	Gear Housing Drain Screw Gasket	12-19183	1
18-7163	O-Ring	25-33465	1
18-7159	O-Ring	25-31534	1
18-2002	Oil Seal	26-76868	2
18-0563	Seal	26-36556	1

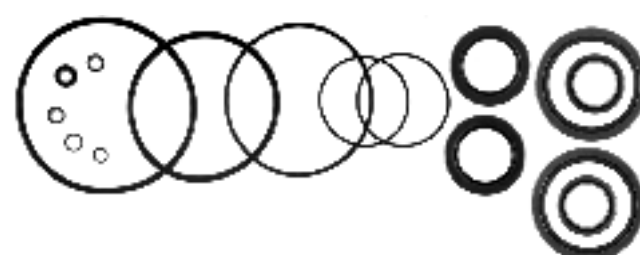

18-2645
AP# 3744
BRAVO LOWER UNIT SEAL KIT
Replaces: 26-76868A2
BRAVO I, II, III

— CONTAINS —			
Sierra#	Description	O.E.#	Qty.
18-2945	Gear Hsg. Drain Screw Gasket	12-19183	2
18-0894	Water Pocket Cover Gasket	27-55810	1
18-2003	Oil Seal	26-68493	1
18-2049	Oil Seal	26-32511	1
18-2056	Oil Seal	26-96503	1
18-2944	Seal Ring	26-45577	1
18-3110	Bushing	26-38970	1
18-7153	O-Ring	25-25439	2
18-7161	O-Ring	25-32546	1
18-7169	O-Ring	25-70937	1
18-7445	O-Ring	25-55801	1



18-2648
AP# 3809
UPPER GEAR HOUSING SEAL KIT
Replaces: 26-32511A1
S/N 1684188 & UP
For #1 Units (Including ALPHA) (Also fits 888 Stern drive)
S/N 3106717 & UP

— CONTAINS —			
Sierra#	Description	O.E.#	Qty.
18-2919	Water Pump to Gear Hsg. Gasket	27-42631-1	1
18-3110	Grommet	26-38970	1
18-2002	Oil Seal	26-76868	1
18-2013	Oil Seal	26-16977	2
18-2014	Oil Seal	26-89238	1
18-2826	Water Pump Base to Gear Hsg. Gasket	27-85610-1	1
18-2914	Lower Water Pump to Wear Plate Gasket	27-85608-1	1
18-2915	Upper Water Pump to Wear Plate Gasket	27-85609-1	1
18-2944	Seal Ring	26-45577	1
18-2948	Gear Housing Plastic Flush Screw Gasket	12-49221-1	1
18-7158	O-Ring	25-30613	1
18-7159	O-Ring	25-31534	1
18-7162	O-Ring	25-33145	1
18-7176	O-Ring	25-90011	1
18-7196	O-Ring	25-38099	1
18-2154	Bushing, Shift Shaft	23-30617A2	1
18-2076	Line Cutter Oil Seal	26-12224	1
18-7426	O-Ring	25-30271	1
18-2945	Gear Housing Drain Screw Gasket	12-20260, 12-19183	2

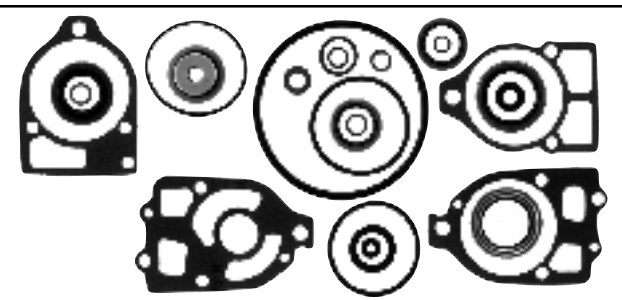

18-2652
AP# 1287
LOWER GEAR HOUSING SEAL KIT
Replaces: 26-33144A2
S/N 1684188 & UP
For #1 Units (Including ALPHA)

NEW



18-8371
UPPER GEARCASE SEAL KIT
For: TR & TRS Drives



18-8370
AP# 1800
COMPLETE LOWER GEAR CASE REBUILD KIT
Includes Water Pump and Complete Seal Kit
For Mercruiser R/MR/ALPHA 1



Display Package

18-4456
AP# 5018
3" EXHAUST PROTECTOR VALVE
Replaces: 34765A1, 34765A2
INCLUDES STAINLESS STEEL CLAMP



Display Package

18-4457
AP# 5019
4" EXHAUST PROTECTOR VALVE
Replaces: 12644A1
INCLUDES STAINLESS STEEL CLAMP



Display Package

18-4458
AP# 5023
EXHAUST PROTECTOR VALVE
(Fits both 5" & 6" Exhaust)
INCLUDES STAINLESS STEEL CLAMP

Stern Drive Model	Years	S/N	Bearing Carrier O-Ring	Bearing Carrier Seals	Upper Unit Seal Kit	Lower Unit Seal & Brg. Kit	Lower Unit Seal Kit	U-Joint Carrier Seal
60/80/90	1965-72	1830753 - 3225967	18-7160	18-2011/18-2015	N/A	N/A	N/A	N/A
I	1963	1534570 - 1684187	18-7157	18-2002	18-2648	N/A	18-2652	18-0577
IA, IB, IC & EZ Shift	1964-66	1684188 - 2065189	18-7157	18-2002	18-2648	N/A	18-2652	18-0577
120/140	1967-69	2062141 - 6225576	18-7157	18-2002	18-2648	N/A	18-2652	18-0577
470/485	1976-82	4208730 - 6225576	18-7157	18-2002	18-2648	N/A	18-2652	18-0577
160/165	1967-77	2065190 - UP	18-7157	18-2002	18-2648	N/A	18-2652	18-0577
888	1971-77	3106717 - UP	18-7157	18-2002	18-2648	N/A	18-2652	18-0577
225/233	1974-77	3856268 - UP	18-7157	18-2002	18-2648	N/A	18-2652	18-0577
898/228/250/260	1977-82	4782330 - 4898729	18-7157	18-2002	18-2648	N/A	18-2652	18-0577
R	1983	6225577 - UP	18-7157	18-2002	18-2648	18-8207	18-2652	18-0577
MR / Alpha One	1984-90	6225577 - UP	18-7157	18-2002	18-2648	18-8208	18-2652	18-0577
MR / Alpha One	1984-90	6225577 - UP	18-7157	18-2077/18-2076	18-2648	18-8208	18-2652	18-0577
MR / Alpha One (CR)	1984-90	6225577 - UP	18-7157	18-2077/18-2076	18-2648	—	18-2652	18-0577
Alpha One SS	1986-89	A545004 - UP	18-7157	18-2002	18-2648	—	18-2652	18-0577
Alpha One SS	1986-89	A545004 - UP	18-7157	18-2077/18-2076	18-2648	—	18-2652	18-0577
Alpha One Gen II	1991-95	D469859 - F679999	18-7157	18-2077/18-2076	18-2644	18-8209	18-2646-1	18-0577
Alpha One Gen II (CR)	1991-95	D469859 - F679999	18-7157	18-2077/18-2076	18-2644	—	18-2646-1	18-0577
Alpha One Gen II	1996-97	F680000 - K999999	18-7157	18-2077/18-2076	18-2644	—	18-2646-1	18-0577
Alpha One Gen II (CR)	1996-newer	F680000 - UP	18-7157	18-2077/18-2076	18-2644	—	18-2646-1	18-0577
Alpha One Gen II	1998-newer	L100040 - UP	18-7157	18-2077/18-2076	18-2644	—	18-2646-1	18-0577
Bravo I	1988-newer	B664190 - UP	18-7157	18-2002	18-2643	—	18-2645	—
Bravo II	1988-newer	B664190 - UP	18-7453	— /18-0536	18-2643	—	18-2645	—
Bravo III	1988-newer	B664190 - UP	18-7447	—	18-2643	—	18-2645	—
Blackhawk	1994-95	F186717 - UP	18-7451	—	18-2643	—	N/A	—
II	1962-69	1474909 - 2671321	18-7157	—	N/A	—	N/A	—
III	1968-72	2373127 - 3002613	—	—	N/A	—	N/A	—
215E/H	1970-72	2909035 - 2915034	18-7453	18-0536	N/A	—	N/A	—
TR	1973-93	3377316 - UP	18-7453	—	N/A	—	N/A	—
TRS	1973-93	3377316 - UP	18-7157	18-2002	N/A	—	N/A	—

① Line Cutter Seal

