

MERCUISER INBOARD/OUTDRIVE MODEL IDENTIFICATION

| SEA RAY | | | GM V6 (STERN DRIVE) Cont. | | |
|--|-----------------|---------|---|-----------------|---------|
| MODEL NO. | S/N | YEAR | MODEL | S/N | YEAR |
| 3.0L | B787205-B917529 | 1988 | 205 (4bbl.) | A331455-B527954 | 1985-87 |
| 4.3L | B785483-B921276 | 1988 | 205/4.3LX (4bbl.) | B527955-D714369 | 1987-91 |
| 4.3LX | B785981-B922330 | 1988 | 4.3LX (GEN II)(4bbl.) | D714370-F001219 | 1992-93 |
| 5.7L | B784799-B917017 | 1988 | 4.3LX (GEN II)(4bbl.) | F001220-F601126 | 1993-95 |
| SRX5.7L, 350 Mag | B785241-B919012 | 1988 | 4.3LX (GEN II)(4bbl.) | F601127-F802999 | 1996 |
| SRX7.4L, 454 Mag Alpha | B785149-B924857 | 1988 | 4.3LXH (GEN+)(4bbl.) | F803114-UP | 1996-97 |
| SRX7.4L-H, 454 Mag Bravo | B721206-B919343 | 1988 | 4.3LH(GEN+)(4bbl.) | L010044-UP | 1998 |
| STERN DRIVES | | | 262 Mag. (TBI)(GEN+) | F803800-K999999 | 1996-97 |
| MODEL NO. | S/N | YEAR | FORD V8 (STERN DRIVE) | | |
| SRX7.4L, Alpha | B803866-C348032 | 1988 | MODEL | S/N | YEAR |
| SRX7.4L-H, Bravo | B803872-B999972 | 1988 | 888 (2bbl.) | 3108723-4887829 | 1971-77 |
| INBOARD ENGINES | | | 215 (4bbl.) | 2781153-3385720 | 1970-72 |
| MODEL NO. | S/N | YEAR | 225 (4bbl.) | 3385721-4166999 | 1973-74 |
| 5.7L | B788204-B919356 | 1988 | 225-S (4bbl.) | 3385721-4166999 | 1973-74 |
| 7.4L | B788179-B913769 | 1988 | 233 | 4173000-4902304 | 1975-77 |
| RENAULT 4 CYLINDER (STERN DRIVE) | | | 255 | 3258728-4175499 | 1971-74 |
| MODEL | S/N | YEAR | GM V8 283, 327, 305 & 350 CID | | |
| 60 | 1887079-2049044 | 1965-68 | MODEL | S/N | YEAR |
| 80 | 2049045-2851423 | 1966-69 | 190 | 1564539-1730903 | 1963-64 |
| 90 | 2851424-3226957 | 1970-72 | 898 (2bbl.) | 4762210-6218461 | 1977-82 |
| GM 4 CYLINDER (STERN DRIVE) | | | 898 (2bbl.) | 6218462-B525981 | 1983-84 |
| MODEL | S/N | YEAR | 200/5.0L (2bbl.) | 6218462-F600999 | 1985-95 |
| 110 | 1537370-2044033 | 1963-66 | 5.0L (2bbl.) | L015751-UP | 1998-UP |
| 120 | 1666601-3377340 | 1964-72 | 5.0L EFI | L012052-L340000 | 1998-99 |
| 120 | 3377341-3770649 | 1972-73 | 228 (4bbl.) | 4765100-5170008 | 1977-78 |
| 120 | 3770650-4952700 | 1974-77 | 228 (4bbl.) | 5170009-6218461 | 1979-82 |
| 120 | 4952701-5192048 | 1978 | 228 (4bbl.) | 6218462-B525981 | 1982-84 |
| 120 | 5192049-6229717 | 1979-82 | 230 (4bbl.) | 6218462-B525981 | 1985-86 |
| 120 | 6229718-6853913 | 1983-84 | 230/5.0LX (4bbl.) | B525982-F600999 | 1987-95 |
| 120 | 6853914-B531853 | 1985-86 | 225 | 1539620-2694014 | 1963-69 |
| 120/2.5L | B531854-C853255 | 1987-89 | 250 | 2314301-2639854 | 1968-69 |
| 140 | 2508261-6229717 | 1968-82 | 255 | 4175500-4767999 | 1975-76 |
| 140/3.0L | 6229718-C856558 | 1982-89 | 250 | 4768000-4908849 | 1977 |
| 3.0L/LX | C856559-UP | 1990-UP | 260/5.7L | 4908850-6218461 | 1978-82 |
| MERCURY MARINE 4 CYLINDER (STERN DRIVE) | | | 260/5.7L | 621462-B525981 | 1982-86 |
| MODEL | S/N | YEAR | 260/5.7L | B525982-F600999 | 1987-95 |
| 470 (2bbl.) | 4208730-5520114 | 1976-79 | 5.7L (2bbl.) | F601000-UP | 1996-98 |
| 470 (2bbl.) | 5520115-6218036 | 1980-82 | 5.7L EFI | F225560-UP | 1995-UP |
| 470 (2bbl.) | 6218037-6916778 | 1983-84 | 5.7LX (4bbl.) | F601000-K999999 | 1996-97 |
| 170 (2bbl.) | 6916779-UP | 1985-86 | 5.7LX EFI | F752400-K999999 | 1996-97 |
| 165/3.7L (2bbl.) | 6916779-UP | 1987-89 | 5.7LX Bravo EFI | F800300-K999999 | 1996-97 |
| 485 (2bbl.) | 5685394-6218036 | 1980-82 | 350 Mag. Alpha | A635178-B525981 | 1986-87 |
| 488 (4bbl.) | 6170297-6916778 | 1983-84 | 350 Mag. Alpha | B525982-F600999 | 1987-95 |
| 190 (4bbl.) | 6916779-UP | 1985-86 | 350 Mag. Alpha | F601000-K001526 | 1996 |
| 180/3.7LX (4bbl.) | 6916779-UP | 1987-89 | 350 Mag. Alpha | K001527-K999999 | 1997 |
| GM INLINE 6 CYLINDER (STERN DRIVE) | | | 350 Mag. Alpha EFI | F800300-K999999 | 1996-97 |
| MODEL | S/N | YEAR | 350 Mag. Bravo MPI | F415189-K999999 | 1995-97 |
| 140 | 1538930-1725960 | 1963 | 350 Mag. Bravo MPI | | |
| 150 | 1666495-2048046 | 1964-66 | (GEN +) | F602000-K999999 | 1996-97 |
| 160 | 2048022-2770031 | 1967-69 | 350 Mag. MPI (GEN+) | L010019-UP | 1998-UP |
| 165 | 2770032-5178958 | 1970-78 | 270 | 2851074-3385720 | 1969-72 |
| 165 | 5178959-5813433 | 1979-81 | 280TRS | 4176250-4770199 | 1975-76 |
| 200 | 2453769-2712072 | 1969 | 300 Tempest | 6668677-B430367 | 1985-86 |
| GM V6 (STERN DRIVE) | | | 320 (EFI) | A543604-C622418 | 1987-89 |
| MODEL | S/N | YEAR | GM V8 427, 454, 502, 540 & 572 (STERN DRIVE) | | |
| 185 (4bbl.) | 6330183-6919655 | 1983-84 | MODEL | S/N | YEAR |
| 185 (2bbl.) | A331455-B527954 | 1985-87 | 325 | 2278747-3780449 | 1969-72 |
| 175/4.3L (2bbl.) | B527955-D714106 | 1987-92 | 330 | 4623115-6083144 | 1977-81 |
| 4.3L (GEN II)(2bbl.) | D714107-F000877 | 1992-93 | 330 | 6083145-B816450 | 1982-87 |
| 4.3L (GEN II)(2bbl.) | F000878-F601126 | 1993-95 | 7.4L Bravo | B771113-D603117 | 1988-91 |
| 4.3L (GEN II)(2bbl.) | F601127-F000878 | 1996 | 7.4L Bravo (Gen.V) | D603118-F800699 | 1992-96 |
| 4.3LX (GEN+)(2bbl.) | F803000-K999999 | 1996-97 | 7.4L Bravo (Gen.VI) | F800700-K999999 | 1996-97 |
| 4.3L (GEN+)(2bbl.) | L010044-UP | 1998-UP | 7.4LX Bravo (MPI)(Gen.V) | F602010-F801999 | 1996 |
| 4.3L EFI (GEN+)(TBI) | L012009-UP | 1998-UP | 7.4LX Bravo (MPI)(Gen.VI) | F802000-K999999 | 1996-97 |



| MERCUISER INBOARD/OUTDRIVE MODEL IDENTIFICATION | | | | | |
|---|------------------|-----------------|--|-----------------|---------|
| GM V8 427, 454, 502, 540 & 572 (STERN DRIVE) Cont. | | | GM MIE V8 305,327,350 CID (INBOARD) Cont. | | |
| MODEL | S/N | YEAR | MODEL | S/N | YEAR |
| 7.4L MPI (Gen. VI) | L010003-UP | 1998 | 228 | 4765100-5170008 | 1977-78 |
| 7.4LX Bravo (TBI)(Gen.VI) | F820000-K999999 | 1996-97 | 228 | 5170009-5907057 | 1979-80 |
| 454 Mag. Alpha | A631894-UP | 1986-88 | 230/5.0L (4bbl.) | 5907058-B788151 | 1981-87 |
| 454 Mag. Bravo (Gen.V) | D805069-F304999 | 1992-94 | 225 | 2278647-2694014 | 1968 |
| 454 Mag. Bravo (Gen.V) | F305000-F801699 | 1995-96 | 250 | 2314301-2639854 | 1968-69 |
| 454 Mag. Bravo (Gen.VI) | F801700-K999999 | 1996-97 | 255 | 4175500-5907057 | 1975-80 |
| 454 EFI (Gen.V) | F115700-F802349 | 1994-96 | 260/5.7L | 5907058-F024999 | 1981-93 |
| 454 Mag. MPI (Gen.VI) | F802350-K999999 | 1996-97 | 270 | 2851074-3077735 | 1969-72 |
| 454 Mag. MPI (Gen.VI) | L010029-L085399 | 1998 | 5.7L | F025000-K999999 | 1994-97 |
| 454 Mag. MPI (Gen.VI) | L085400-UP | 1999-UP | 5.7L (Gen+) | L002003-UP | 1998 |
| 370 TRS | 4179554-6721527 | 1978-85 | 5.7L MPI | K040300-K999999 | 1997 |
| 370 TRS | 6721528-B714586 | 1985-87 | 350 Mag. MPI (Gen+) | L002008-L304499 | 1998 |
| 400 TRS | 4179554-B457644 | 1980-86 | 350 Mag. MPI (Gen+) | L304500-UP | 1999 |
| 420 | A398941-D937011 | 1987-89 | 350 Horizon | L304700-UP | 1999-UP |
| 425 | A398941-D937011 | 1990-93 | 5.7L Ski | A338533-B514626 | 1985-87 |
| 440 TRS | 4179554-B485220 | 1983-86 | 5.7L Competition Ski | B514627-F775199 | 1987-95 |
| 450 (Gen. V) | F347100-F347277 | 1995-96 | 5.7L Competition Ski | F775200-K040003 | 1996 |
| 525 SC | D456000-F348963 | 1991-92 | 5.7L Competition Ski | K040004-K999999 | 1997 |
| 525 SC (Gen.V) | D456000-F348963 | 1992-95 | 5.7L Competition Ski | | |
| 525 SC (Gen.V) | F615814-F745215 | 1996 | (Gen+) | L002005-UP | 1998-UP |
| 525 SC (Gen.VI) | F745260-UP | 1996-97 | 350 Mag. Ski | D505450-K999999 | 1991-97 |
| 390 | 2781129-3042731 | 1969-70 | 350 Mag. EFI Ski | F215561-K999999 | 1994-97 |
| 460 TRS | 4719554-6181046 | 1983-86 | 350 Mag. MPI Ski | F350583-F799999 | 1995-98 |
| 465 | C849992-F213244 | 1990-92 | Black Scorpion Ski | F800000-UP | 1996-98 |
| 465 (Gen.V) | C849992-F213244 | 1992-94 | | | |
| 500 (Gen.V) | F213293-F745159 | 1994-96 | | | |
| 500 (Gen.VI) | F745195-L001772 | 1997-98 | | | |
| 502 Mag. Bravo | C878221-D824588 | 1990-92 | | | |
| 502 Mag. Bravo (Gen.V) | D824589-F114528 | 1992-93 | | | |
| 502 EFI (Gen.V) | D840650-F802599 | 1993-96 | | | |
| 502 Mag.MPI (Gen.VI) | F802600-K999999 | 1996-97 | | | |
| 500 EFI | L001477-UP | 1999-UP | | | |
| 502 Mag.MPI (Gen.VI) | L085433-UP | 1998 | | | |
| 600 SC | D456489-F877642 | 1991-92 | | | |
| 600 SC (Gen.V) | D456489-F877642 | 1992-96 | | | |
| 600 SC (Gen.VI) | K000227-UP | 1997 | | | |
| 500 Bulldog | C577254-F745405 | 1990-96 | | | |
| 500 Bulldog | K000248-UP | 1997 | | | |
| 575 | A677429-D763716 | 1986-92 | | | |
| 800 SC (Gen.V) | D763836-UP | 1993-96 | | | |
| MCM 4,5,6 & V8 CYLINDER DIESEL STERN DRIVE ENGINE | | | | | |
| MODEL | HP | S/N | YEAR | | |
| Rover | 60 | 3140000F-UP | 1965-67 | | |
| 530 D-TA | 150 | B993000-B993492 | 1989 | | |
| 636 D-TA | 180 | B993500-C696047 | 1989 | | |
| D183 | 140 | B993493-D725149 | 1990-93 | | |
| D219 | 170 | C696048-D850124 | 1990-93 | | |
| D254 | 200 | C849484-D554729 | 1990-93 | | |
| D3.0L | 140 | D725150-UP | 1994-UP | | |
| D3.6L | 170 | D850125-UP | 1994-UP | | |
| D4.2L | 200 | D554730-UP | 1994-UP | | |
| D7.3L | 238 | F060000-UP | 1994-UP | | |
| MERCURY MARINE MIE 4 CYLINDER (INBOARD) | | | | | |
| MODEL | S/N | YEAR | | | |
| 470 | 5520115-6218036 | 1980-81 | | | |
| FORD MIE V8 (INBOARD) | | | | | |
| MODEL | S/N | YEAR | | | |
| 215 | 2781153-3563181 | 1970-72 | | | |
| 225 | 3385721-4176999 | 1970-72 | | | |
| 233 | 4173000-4775784 | 1975-76 | | | |
| 255 | 3258728-4178299 | 1973-74 | | | |
| GM MIE V8 305,327,350 CID (INBOARD) | | | | | |
| MODEL | S/N | YEAR | | | |
| 198 | 4762210-6218461 | 1977 | | | |
| GM MIE V8 427, 454, 482 & 502 CID (INBOARD) | | | | | |
| MODEL | S/N | YEAR | | | |
| 325 | 2278747-3780449 | 1968-74 | | | |
| 330 | 4623115-5889913 | 1977-80 | | | |
| 340/7.4L w/B/W MK4 | 5889914-UP | 1981-92 | | | |
| 7.4L w/Hurth (LH) MK4 | C391564-D715493 | 1989-92 | | | |
| 7.4L (LH) | D715494-K999999 | 1992-97 | | | |
| 7.4L MPI (LH) | F563052-K999999 | 1995-97 | | | |
| 7.4L MPI (L29) Gen VI | L002006-UP | 1998 | | | |
| 7.4L TBI (LH) Gen VI | F874815-K999999 | 1996-97 | | | |
| 454 Mag. MPI Horizon | L002200-L086049 | 1998-99 | | | |
| 454 EFI (SKI) (Gen.V) | F215800-F820099 | 1995-96 | | | |
| 454 Mag. MPI (SKI)(Gen.VI) | F820100-K999999 | 1996-97 | | | |
| 350 | 9780450-4623109 | 1974-76 | | | |
| 390 | 2781129-2825059 | 1969-70 | | | |
| 8.2L w/ Hurth | C878221-D857199 | 1990-92 | | | |
| 8.2L (Gen.V) | D857200-F819619 | 1993-96 | | | |
| 8.2L MPI (LH) Gen VI | F819620-K999999 | 1996-97 | | | |
| 8.2L MPI (LH) Gen VI | L002450-L0086012 | 1998 | | | |
| 8.2L MPI (LH) Gen VI | L0086013-UP | 1999 | | | |
| MIE 5, 6 & V8 CYLINDER DIESEL INBOARD ENGINES | | | | | |
| MODEL | HP | S/N | YEAR | | |
| 530 D-TA | 150 | B993002-C539258 | 1989 | | |
| 636 D-TA | 180 | B993750-C696011 | 1989 | | |
| D183 | 150 | C539259-D725149 | 1990-93 | | |
| D219 | 180 | C696012-D850124 | 1990-93 | | |
| D254 | 210 | C849461-D554729 | 1990-93 | | |
| D3.0L | 150 | D725150-UP | 1994-UP | | |
| D3.6L | 180 | D850125-UP | 1994-UP | | |
| D4.2L | 210 | D554730-UP | 1994-UP | | |
| D7.3L | 262 | F060000-UP | 1994-UP | | |
| MC 60, 80 & 90 STERN DRIVES & TRANSOM PLATES | | | | | |
| MODEL | S/N | YEAR | | | |
| 60 (O) | 1830753-2063740 | 1965-66 | | | |
| 80 | 2063741-2898029 | 1966-69 | | | |
| 90 | 2898020-3225967 | 1970-72 | | | |
| MC I, II & III | | | | | |
| MODEL | S/N | YEAR | | | |
| I | 1534570-1684187 | 1963 | | | |
| II (1.33:1) | 1474909-2278488 | 1962-67 | | | |



MERCRUISER INBOARD/OUTDRIVE MODEL IDENTIFICATION

| MC I, II & III Cont. | | | MC 898, 228, 250 & 260 | | |
|-------------------------|-----------------|---------|--|-----------------|---------|
| MODEL | S/N | YEAR | MODEL | S/N | YEAR |
| II (1.78:1) | 2398798-2671321 | 1968-69 | 898/228 | 4782330-4898729 | 1977 |
| III | 2373127-3002613 | 1968-72 | 898/228 | 4898730-6229157 | 1978-82 |
| III | 5128065-UP | 1978-UP | 250 | 4791300-4898729 | 1977 |
| | | | 260 | 4898730-6229157 | 1978-82 |
| MC 1A, 1B & 1C | | | MC R, MR, ALPHA ONE, ALPHA ONE SS & ALPHA ONE GEN II | | |
| MODEL | S/N | YEAR | MODEL | S/N | YEAR |
| 1A, 1B & 1C | 1684188-1777798 | 1964 | R | 6152230-6847029 | 1983-84 |
| 1A, 1B & 1C (E-Z Shift) | 1776349-2065189 | 1965-66 | MR | 6810538-A479506 | 1985 |
| MC 120, 140, 160 & 165 | | | Alpha One, Alpha One SS, Alpha One Gen II | | |
| MODEL | S/N | YEAR | Alpha One | A470165-UP | 1986-90 |
| 120/140 | 2062141-378049 | 1967-73 | Alpha One SS | A545004-UP | 1986-89 |
| 120/140 | 3780850-4893634 | 1974-77 | Alpha One Gen II | D469859-UP | 1991-UP |
| 120/140 | 4893635-6225576 | 1978-82 | MC BRAVO & BLACKHAWK | | |
| 160 | 2065190-2763441 | 1967-69 | MODEL | S/N | YEAR |
| 165 | 2763442-3780849 | 1970-73 | Bravo One | B664190-UP | 1988-UP |
| 165 | 3780849-4890459 | 1974-77 | Bravo Two | C564952-UP | 1989-UP |
| 165 | 4890460-6268064 | 1978-82 | Bravo Three | D763691-UP | 1993-UP |
| MC470 & 485 | | | Blackhawk | F186717-UP | 1994-UP |
| MODEL | S/N | YEAR | MC 215E & 215H | | |
| 470 | 4208730-4893834 | 1976-77 | MODEL | S/N | YEAR |
| 470 | 4893835-6225576 | 1978-82 | 215H | 2782203-2909034 | 1970 |
| 485 | 5487437-6225576 | 1980-82 | 215E | 2782203-2909034 | 1970-72 |
| MC 888, 225S & 233 | | | MC TR & TRS | | |
| MODEL | S/N | YEAR | MODEL | S/N | YEAR |
| 888 | 3106717-3784374 | 1971-73 | TR | 3377316-3787239 | 1973 |
| 888 | 3784375-4782329 | 1974-77 | TR | 3787240-4794899 | 1974-76 |
| 225S | 3856268-4200499 | 1974 | TR | 4794900-5009866 | 1977 |
| 233 | 4200500-4782329 | 1975-77 | TR | 5009867-UP | 1978-UP |
| | | | TRS | 3787240-4203749 | 1974-75 |
| | | | TRS | 4203750-4795399 | 1976 |
| | | | TRS | 4795400-UP | 1977-UP |



18-5291
TUNE-UP KIT
Replaces: 808483K2
GM V-8 engines w/Delco HEI-1998 and newer
(except MPI engines with 555 ECM)



18-5246
TUNE-UP KIT
Replaces: 898253T28
For: Late model V-6, 4.3L (Alpha/Bravo)



18-5247
TUNE-UP KIT
Replaces: 898253T29
For: Late model V-8 (Alpha/Bravo 350
Mag, 5.0L, & MX 6.2L)



18-5249
TUNE-UP KIT
—CONTAINS—
Replaces: 805759T3 / 805759Q3
Part # O.E.# Description
18-5431 13524A5 Rotor
18-5380 — *Distributor Cap
Mercury Thunderbolt HEI-V-8

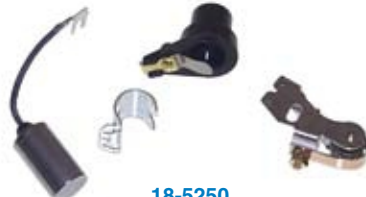

18-5250D
TUNE-UP KIT
—CONTAINS—
Part # O.E.# Description
18-5311 34235 Contact Set
18-5345 33662 Condenser
18-5418 58217 Rotor
Delco 4 & 6 cyl.



18-5251D
TUNE-UP KIT
—CONTAINS—
Part # O.E.# Description
18-5314 391-5090 Contact Set
18-5338 391-5092 Condenser
18-5404-1 391-7057 Rotor
Mallory 8 cyl. Tall Cap

① Items ending in "D" are Display Packaged - Regular number is Non-Display

|  <p>18-5252 TUNE-UP KIT —CONTAINS—</p> <table border="1"> <thead> <tr> <th>Part #</th> <th>O.E. #</th> <th>Description</th> </tr> </thead> <tbody> <tr> <td>18-5310</td> <td>33700</td> <td>Contact Set</td> </tr> <tr> <td>18-5344</td> <td>33706</td> <td>Condenser</td> </tr> </tbody> </table> <p>Delco 8 cyl.</p> | Part # | O.E. # | Description | 18-5310 | 33700 | Contact Set | 18-5344 | 33706 | Condenser |  <p>18-5253 TUNE-UP KIT —CONTAINS—</p> <table border="1"> <thead> <tr> <th>Part #</th> <th>O.E. #</th> <th>Description</th> </tr> </thead> <tbody> <tr> <td>18-5318</td> <td>58033</td> <td>Contact Set</td> </tr> <tr> <td>18-5346</td> <td>58034, 81-64851</td> <td>Condenser</td> </tr> <tr> <td>18-5420</td> <td>65864</td> <td>Rotor</td> </tr> </tbody> </table> <p>Autolite 8 cyl.</p> | Part # | O.E. # | Description | 18-5318 | 58033 | Contact Set | 18-5346 | 58034, 81-64851 | Condenser | 18-5420 | 65864 | Rotor |  <p>18-5254 TUNE-UP KIT —CONTAINS—</p> <table border="1"> <thead> <tr> <th>Part #</th> <th>O.E. #</th> <th>Description</th> </tr> </thead> <tbody> <tr> <td>18-5317</td> <td>64850, 87-71831</td> <td>Contact Set</td> </tr> <tr> <td>18-5346</td> <td>58034, 81-64851</td> <td>Condenser</td> </tr> <tr> <td>18-5420</td> <td>65864, 78016</td> <td>Rotor</td> </tr> </tbody> </table> <p>Mercury 8 cyl.</p> | Part # | O.E. # | Description | 18-5317 | 64850, 87-71831 | Contact Set | 18-5346 | 58034, 81-64851 | Condenser | 18-5420 | 65864, 78016 | Rotor | | | | | | | | | | | | |
|---|--------------------|-----------------|-------------|---------|----------|-------------|---------|-----------------|-----------|--|--------------|-----------------|---|-----------|-----------------|--|---------|-----------------|-------------|---------|----------|-------------|---|--------------------|-----------|--|----------|-----------------|--|----------|-----------------|--|---------|--------------|-------------|---------|---------|-----------------|---------|-------|-----------|---------|-------|-------|---------|-------|-----------------|
| Part # | O.E. # | Description | | | | | | | | | | | | | | | | | | | | | | | | | | | | | | | | | | | | | | | | | | | | | |
| 18-5310 | 33700 | Contact Set | | | | | | | | | | | | | | | | | | | | | | | | | | | | | | | | | | | | | | | | | | | | | |
| 18-5344 | 33706 | Condenser | | | | | | | | | | | | | | | | | | | | | | | | | | | | | | | | | | | | | | | | | | | | | |
| Part # | O.E. # | Description | | | | | | | | | | | | | | | | | | | | | | | | | | | | | | | | | | | | | | | | | | | | | |
| 18-5318 | 58033 | Contact Set | | | | | | | | | | | | | | | | | | | | | | | | | | | | | | | | | | | | | | | | | | | | | |
| 18-5346 | 58034, 81-64851 | Condenser | | | | | | | | | | | | | | | | | | | | | | | | | | | | | | | | | | | | | | | | | | | | | |
| 18-5420 | 65864 | Rotor | | | | | | | | | | | | | | | | | | | | | | | | | | | | | | | | | | | | | | | | | | | | | |
| Part # | O.E. # | Description | | | | | | | | | | | | | | | | | | | | | | | | | | | | | | | | | | | | | | | | | | | | | |
| 18-5317 | 64850, 87-71831 | Contact Set | | | | | | | | | | | | | | | | | | | | | | | | | | | | | | | | | | | | | | | | | | | | | |
| 18-5346 | 58034, 81-64851 | Condenser | | | | | | | | | | | | | | | | | | | | | | | | | | | | | | | | | | | | | | | | | | | | | |
| 18-5420 | 65864, 78016 | Rotor | | | | | | | | | | | | | | | | | | | | | | | | | | | | | | | | | | | | | | | | | | | | | |
|  <p>18-5258 TUNE-UP KIT —CONTAINS—</p> <table border="1"> <thead> <tr> <th>Part #</th> <th>O.E. #</th> <th>Description</th> </tr> </thead> <tbody> <tr> <td>18-5303</td> <td>392-6325</td> <td>Contact Set</td> </tr> <tr> <td>18-5347</td> <td>392-6324</td> <td>Condenser</td> </tr> <tr> <td>18-5407</td> <td>392-6326</td> <td>Rotor</td> </tr> </tbody> </table> <p>Prestolite 8 cyl.</p> | Part # | O.E. # | Description | 18-5303 | 392-6325 | Contact Set | 18-5347 | 392-6324 | Condenser | 18-5407 | 392-6326 | Rotor |  <p>18-5260 TUNE-UP KIT —CONTAINS—</p> <table border="1"> <thead> <tr> <th>Part #</th> <th>O.E. #</th> <th>Description</th> </tr> </thead> <tbody> <tr> <td>18-5303</td> <td>392-6325</td> <td>Contact Set</td> </tr> <tr> <td>18-5345</td> <td>392-6324</td> <td>Condenser</td> </tr> <tr> <td>18-5403</td> <td>392-9767</td> <td>Rotor</td> </tr> </tbody> </table> <p>Prestolite 8 cyl.</p> | Part # | O.E. # | Description | 18-5303 | 392-6325 | Contact Set | 18-5345 | 392-6324 | Condenser | 18-5403 | 392-9767 | Rotor |  <p>18-5266 TUNE UP KIT</p> <p>Fits: Flame Thrower Distributors 18-5481, 18-5482 and 18-5483</p> | | | | | | | | | | | | | | | | | | | | | |
| Part # | O.E. # | Description | | | | | | | | | | | | | | | | | | | | | | | | | | | | | | | | | | | | | | | | | | | | | |
| 18-5303 | 392-6325 | Contact Set | | | | | | | | | | | | | | | | | | | | | | | | | | | | | | | | | | | | | | | | | | | | | |
| 18-5347 | 392-6324 | Condenser | | | | | | | | | | | | | | | | | | | | | | | | | | | | | | | | | | | | | | | | | | | | | |
| 18-5407 | 392-6326 | Rotor | | | | | | | | | | | | | | | | | | | | | | | | | | | | | | | | | | | | | | | | | | | | | |
| Part # | O.E. # | Description | | | | | | | | | | | | | | | | | | | | | | | | | | | | | | | | | | | | | | | | | | | | | |
| 18-5303 | 392-6325 | Contact Set | | | | | | | | | | | | | | | | | | | | | | | | | | | | | | | | | | | | | | | | | | | | | |
| 18-5345 | 392-6324 | Condenser | | | | | | | | | | | | | | | | | | | | | | | | | | | | | | | | | | | | | | | | | | | | | |
| 18-5403 | 392-9767 | Rotor | | | | | | | | | | | | | | | | | | | | | | | | | | | | | | | | | | | | | | | | | | | | | |
|  <p>18-5267 TUNE-UP KIT —CONTAINS—</p> <table border="1"> <thead> <tr> <th>Part #</th> <th>O.E. #</th> <th>Description</th> </tr> </thead> <tbody> <tr> <td>18-5318</td> <td>58033</td> <td>Contact Set</td> </tr> <tr> <td>18-5346</td> <td>58034, 81-64851</td> <td>Condenser</td> </tr> <tr> <td>18-5420</td> <td>65864, 78016</td> <td>Rotor</td> </tr> <tr> <td>18-5389</td> <td>393-4988T</td> <td>Distributor Cap</td> </tr> </tbody> </table> <p>Autoilite V-8 - Single Point</p> | Part # | O.E. # | Description | 18-5318 | 58033 | Contact Set | 18-5346 | 58034, 81-64851 | Condenser | 18-5420 | 65864, 78016 | Rotor | 18-5389 | 393-4988T | Distributor Cap |  <p>18-5268 TUNE-UP KIT —CONTAINS—</p> <table border="1"> <thead> <tr> <th>Part #</th> <th>O.E. #</th> <th>Description</th> </tr> </thead> <tbody> <tr> <td>18-5311</td> <td>34235</td> <td>Contact Set</td> </tr> <tr> <td>18-5345</td> <td>33662</td> <td>Condenser</td> </tr> <tr> <td>18-5418</td> <td>58217</td> <td>Rotor</td> </tr> <tr> <td>18-5385</td> <td>393-9459</td> <td>Distributor Cap</td> </tr> </tbody> </table> <p>Delco In-Line 4 - Single Point</p> | Part # | O.E. # | Description | 18-5311 | 34235 | Contact Set | 18-5345 | 33662 | Condenser | 18-5418 | 58217 | Rotor | 18-5385 | 393-9459 | Distributor Cap |  <p>18-5269 TUNE-UP KIT —CONTAINS—</p> <table border="1"> <thead> <tr> <th>Part #</th> <th>O.E. #</th> <th>Description</th> </tr> </thead> <tbody> <tr> <td>18-5311</td> <td>34235</td> <td>Contact Set</td> </tr> <tr> <td>18-5345</td> <td>33662</td> <td>Condenser</td> </tr> <tr> <td>18-5418</td> <td>58217</td> <td>Rotor</td> </tr> <tr> <td>18-5386</td> <td>33765</td> <td>Distributor Cap</td> </tr> </tbody> </table> <p>Delco In-Line 6 - Single Point</p> | Part # | O.E. # | Description | 18-5311 | 34235 | Contact Set | 18-5345 | 33662 | Condenser | 18-5418 | 58217 | Rotor | 18-5386 | 33765 | Distributor Cap |
| Part # | O.E. # | Description | | | | | | | | | | | | | | | | | | | | | | | | | | | | | | | | | | | | | | | | | | | | | |
| 18-5318 | 58033 | Contact Set | | | | | | | | | | | | | | | | | | | | | | | | | | | | | | | | | | | | | | | | | | | | | |
| 18-5346 | 58034, 81-64851 | Condenser | | | | | | | | | | | | | | | | | | | | | | | | | | | | | | | | | | | | | | | | | | | | | |
| 18-5420 | 65864, 78016 | Rotor | | | | | | | | | | | | | | | | | | | | | | | | | | | | | | | | | | | | | | | | | | | | | |
| 18-5389 | 393-4988T | Distributor Cap | | | | | | | | | | | | | | | | | | | | | | | | | | | | | | | | | | | | | | | | | | | | | |
| Part # | O.E. # | Description | | | | | | | | | | | | | | | | | | | | | | | | | | | | | | | | | | | | | | | | | | | | | |
| 18-5311 | 34235 | Contact Set | | | | | | | | | | | | | | | | | | | | | | | | | | | | | | | | | | | | | | | | | | | | | |
| 18-5345 | 33662 | Condenser | | | | | | | | | | | | | | | | | | | | | | | | | | | | | | | | | | | | | | | | | | | | | |
| 18-5418 | 58217 | Rotor | | | | | | | | | | | | | | | | | | | | | | | | | | | | | | | | | | | | | | | | | | | | | |
| 18-5385 | 393-9459 | Distributor Cap | | | | | | | | | | | | | | | | | | | | | | | | | | | | | | | | | | | | | | | | | | | | | |
| Part # | O.E. # | Description | | | | | | | | | | | | | | | | | | | | | | | | | | | | | | | | | | | | | | | | | | | | | |
| 18-5311 | 34235 | Contact Set | | | | | | | | | | | | | | | | | | | | | | | | | | | | | | | | | | | | | | | | | | | | | |
| 18-5345 | 33662 | Condenser | | | | | | | | | | | | | | | | | | | | | | | | | | | | | | | | | | | | | | | | | | | | | |
| 18-5418 | 58217 | Rotor | | | | | | | | | | | | | | | | | | | | | | | | | | | | | | | | | | | | | | | | | | | | | |
| 18-5386 | 33765 | Distributor Cap | | | | | | | | | | | | | | | | | | | | | | | | | | | | | | | | | | | | | | | | | | | | | |
|  <p>18-5270 TUNE-UP KIT —CONTAINS—</p> <table border="1"> <thead> <tr> <th>Part #</th> <th>O.E. #</th> <th>Description</th> </tr> </thead> <tbody> <tr> <td>18-5310</td> <td>33700</td> <td>Contact Set</td> </tr> <tr> <td>18-5344</td> <td>33706</td> <td>Condenser</td> </tr> <tr> <td>18-5384</td> <td>33708</td> <td>Distributor Cap</td> </tr> </tbody> </table> <p>Delco V-8 - Single Point</p> | Part # | O.E. # | Description | 18-5310 | 33700 | Contact Set | 18-5344 | 33706 | Condenser | 18-5384 | 33708 | Distributor Cap |  <p>18-5271 TUNE-UP KIT —CONTAINS—</p> <table border="1"> <thead> <tr> <th>Part #</th> <th>O.E. #</th> <th>Description</th> </tr> </thead> <tbody> <tr> <td>18-5314</td> <td>391-5090</td> <td>Contact Set</td> </tr> <tr> <td>18-5338</td> <td>391-5092</td> <td>Condenser</td> </tr> <tr> <td>18-5404-1</td> <td>391-7057, 391-5088</td> <td>Rotor</td> </tr> <tr> <td>18-5376</td> <td>391-5075</td> <td>Distributor Cap</td> </tr> </tbody> </table> <p>Mallory V-8 - Single Point - Top Terminal</p> | Part # | O.E. # | Description | 18-5314 | 391-5090 | Contact Set | 18-5338 | 391-5092 | Condenser | 18-5404-1 | 391-7057, 391-5088 | Rotor | 18-5376 | 391-5075 | Distributor Cap |  <p>18-5273 TUNE-UP KIT —CONTAINS—</p> <p>Replaces: 805759T3 / 805759Q3</p> <table border="1"> <thead> <tr> <th>Part #</th> <th>O.E. #</th> <th>Description</th> </tr> </thead> <tbody> <tr> <td>18-5431</td> <td>13524A5</td> <td>Rotor</td> </tr> <tr> <td>18-5395</td> <td>16457A4</td> <td>Distributor Cap</td> </tr> </tbody> </table> <p>Mercury Thunderbolt HEI - V-8</p> | Part # | O.E. # | Description | 18-5431 | 13524A5 | Rotor | 18-5395 | 16457A4 | Distributor Cap | | | | | | | | | |
| Part # | O.E. # | Description | | | | | | | | | | | | | | | | | | | | | | | | | | | | | | | | | | | | | | | | | | | | | |
| 18-5310 | 33700 | Contact Set | | | | | | | | | | | | | | | | | | | | | | | | | | | | | | | | | | | | | | | | | | | | | |
| 18-5344 | 33706 | Condenser | | | | | | | | | | | | | | | | | | | | | | | | | | | | | | | | | | | | | | | | | | | | | |
| 18-5384 | 33708 | Distributor Cap | | | | | | | | | | | | | | | | | | | | | | | | | | | | | | | | | | | | | | | | | | | | | |
| Part # | O.E. # | Description | | | | | | | | | | | | | | | | | | | | | | | | | | | | | | | | | | | | | | | | | | | | | |
| 18-5314 | 391-5090 | Contact Set | | | | | | | | | | | | | | | | | | | | | | | | | | | | | | | | | | | | | | | | | | | | | |
| 18-5338 | 391-5092 | Condenser | | | | | | | | | | | | | | | | | | | | | | | | | | | | | | | | | | | | | | | | | | | | | |
| 18-5404-1 | 391-7057, 391-5088 | Rotor | | | | | | | | | | | | | | | | | | | | | | | | | | | | | | | | | | | | | | | | | | | | | |
| 18-5376 | 391-5075 | Distributor Cap | | | | | | | | | | | | | | | | | | | | | | | | | | | | | | | | | | | | | | | | | | | | | |
| Part # | O.E. # | Description | | | | | | | | | | | | | | | | | | | | | | | | | | | | | | | | | | | | | | | | | | | | | |
| 18-5431 | 13524A5 | Rotor | | | | | | | | | | | | | | | | | | | | | | | | | | | | | | | | | | | | | | | | | | | | | |
| 18-5395 | 16457A4 | Distributor Cap | | | | | | | | | | | | | | | | | | | | | | | | | | | | | | | | | | | | | | | | | | | | | |

APPLICATION BEGINS ON PAGE 593

① Items ending in "D" are Display Packaged - Regular number is Non-Display



MERCUISER Ignition System



|  <p style="text-align: right;">Display Package</p> <p style="text-align: center;">18-5274 TUNE-UP KIT —CONTAINS—</p> <table border="0"> <thead> <tr> <th>Part #</th> <th>O.E. #</th> <th>Description</th> </tr> </thead> <tbody> <tr> <td>18-5432</td> <td>13524A6</td> <td>Rotor</td> </tr> <tr> <td>18-5396</td> <td>13753A2, 815407A2</td> <td>Distributor Cap Mercury Thunderbolt HEI - V-6</td> </tr> </tbody> </table> | Part # | O.E. # | Description | 18-5432 | 13524A6 | Rotor | 18-5396 | 13753A2, 815407A2 | Distributor Cap Mercury Thunderbolt HEI - V-6 |  <p style="text-align: right;">Display Package</p> <p style="text-align: center;">18-5275 TUNE-UP KIT —CONTAINS—</p> <table border="0"> <thead> <tr> <th>Part #</th> <th>O.E. #</th> <th>Description</th> </tr> </thead> <tbody> <tr> <td>18-5303</td> <td>392-6325</td> <td>Contact Set</td> </tr> <tr> <td>18-5347</td> <td>392-6324</td> <td>Condenser</td> </tr> <tr> <td>18-5403</td> <td>392-9089</td> <td>Rotor</td> </tr> <tr> <td>18-5352</td> <td>392-9766</td> <td>Distributor Cap</td> </tr> </tbody> </table> <p style="text-align: center;">Prestolite V-8 - Single Point - Screw Cap</p> | Part # | O.E. # | Description | 18-5303 | 392-6325 | Contact Set | 18-5347 | 392-6324 | Condenser | 18-5403 | 392-9089 | Rotor | 18-5352 | 392-9766 | Distributor Cap |  <p style="text-align: right;">Display Package</p> <p style="text-align: center;">18-5276 TUNE-UP KIT —CONTAINS—</p> <table border="0"> <thead> <tr> <th>Part #</th> <th>O.E. #</th> <th>Description</th> </tr> </thead> <tbody> <tr> <td>18-5303</td> <td>392-6325</td> <td>Contact Set</td> </tr> <tr> <td>18-5347</td> <td>392-6324</td> <td>Condenser</td> </tr> <tr> <td>18-5403</td> <td>392-9089</td> <td>Rotor</td> </tr> <tr> <td>18-5353</td> <td>392-9086</td> <td>Distributor Cap</td> </tr> </tbody> </table> <p style="text-align: center;">Prestolite V-6 - Single Point - Screw Cap</p> | Part # | O.E. # | Description | 18-5303 | 392-6325 | Contact Set | 18-5347 | 392-6324 | Condenser | 18-5403 | 392-9089 | Rotor | 18-5353 | 392-9086 | Distributor Cap |
|--|---|--|---|---------|----------|-----------------|---------|----------------------|---|---|----------|--------|-------------|----------|-----------------|--|--|----------|-------------|---------|----------|---------|-----------------|------------|-----------------|---|--------|-----------|-------------|---------|----------|-------------|---------|----------|-----------|---------|----------|-------|---------|----------|-----------------|
| Part # | O.E. # | Description | | | | | | | | | | | | | | | | | | | | | | | | | | | | | | | | | | | | | | | |
| 18-5432 | 13524A6 | Rotor | | | | | | | | | | | | | | | | | | | | | | | | | | | | | | | | | | | | | | | |
| 18-5396 | 13753A2, 815407A2 | Distributor Cap Mercury Thunderbolt HEI - V-6 | | | | | | | | | | | | | | | | | | | | | | | | | | | | | | | | | | | | | | | |
| Part # | O.E. # | Description | | | | | | | | | | | | | | | | | | | | | | | | | | | | | | | | | | | | | | | |
| 18-5303 | 392-6325 | Contact Set | | | | | | | | | | | | | | | | | | | | | | | | | | | | | | | | | | | | | | | |
| 18-5347 | 392-6324 | Condenser | | | | | | | | | | | | | | | | | | | | | | | | | | | | | | | | | | | | | | | |
| 18-5403 | 392-9089 | Rotor | | | | | | | | | | | | | | | | | | | | | | | | | | | | | | | | | | | | | | | |
| 18-5352 | 392-9766 | Distributor Cap | | | | | | | | | | | | | | | | | | | | | | | | | | | | | | | | | | | | | | | |
| Part # | O.E. # | Description | | | | | | | | | | | | | | | | | | | | | | | | | | | | | | | | | | | | | | | |
| 18-5303 | 392-6325 | Contact Set | | | | | | | | | | | | | | | | | | | | | | | | | | | | | | | | | | | | | | | |
| 18-5347 | 392-6324 | Condenser | | | | | | | | | | | | | | | | | | | | | | | | | | | | | | | | | | | | | | | |
| 18-5403 | 392-9089 | Rotor | | | | | | | | | | | | | | | | | | | | | | | | | | | | | | | | | | | | | | | |
| 18-5353 | 392-9086 | Distributor Cap | | | | | | | | | | | | | | | | | | | | | | | | | | | | | | | | | | | | | | | |
|  <p style="text-align: right;">Display Package</p> <p style="text-align: center;">18-5277 TUNE-UP KIT —CONTAINS—</p> <table border="0"> <thead> <tr> <th>Part #</th> <th>O.E. #</th> <th>Description</th> </tr> </thead> <tbody> <tr> <td>18-5303</td> <td>392-6325</td> <td>Contact Set</td> </tr> <tr> <td>18-5347</td> <td>392-6324</td> <td>Condenser</td> </tr> <tr> <td>18-5407</td> <td>392-6326</td> <td>Rotor</td> </tr> <tr> <td>18-5369</td> <td>392-6318</td> <td>Distributor Cap</td> </tr> </tbody> </table> <p style="text-align: center;">Prestolite V-8 - Single Point - Clip Cap</p> | Part # | O.E. # | Description | 18-5303 | 392-6325 | Contact Set | 18-5347 | 392-6324 | Condenser | 18-5407 | 392-6326 | Rotor | 18-5369 | 392-6318 | Distributor Cap |  <p style="text-align: center;">18-5278 TUNE-UP KIT Replaces: 850484T3 Delco EST - V-6</p> |  <p style="text-align: center;">18-5280 TUNE-UP KIT Replaces: 811635Q2 Delco EST - In-Line 4 —CONTAINS—</p> <table border="0"> <thead> <tr> <th>Part #</th> <th>Description</th> <th>O.E. #</th> <th>Qty.</th> </tr> </thead> <tbody> <tr> <td>18-5361</td> <td>Distributor Cap</td> <td>811635, T3</td> <td>1</td> </tr> <tr> <td>18-5406</td> <td>Rotor</td> <td>811636, 1</td> <td>1</td> </tr> </tbody> </table> | Part # | Description | O.E. # | Qty. | 18-5361 | Distributor Cap | 811635, T3 | 1 | 18-5406 | Rotor | 811636, 1 | 1 | | | | | | | | | | | | |
| Part # | O.E. # | Description | | | | | | | | | | | | | | | | | | | | | | | | | | | | | | | | | | | | | | | |
| 18-5303 | 392-6325 | Contact Set | | | | | | | | | | | | | | | | | | | | | | | | | | | | | | | | | | | | | | | |
| 18-5347 | 392-6324 | Condenser | | | | | | | | | | | | | | | | | | | | | | | | | | | | | | | | | | | | | | | |
| 18-5407 | 392-6326 | Rotor | | | | | | | | | | | | | | | | | | | | | | | | | | | | | | | | | | | | | | | |
| 18-5369 | 392-6318 | Distributor Cap | | | | | | | | | | | | | | | | | | | | | | | | | | | | | | | | | | | | | | | |
| Part # | Description | O.E. # | Qty. | | | | | | | | | | | | | | | | | | | | | | | | | | | | | | | | | | | | | | |
| 18-5361 | Distributor Cap | 811635, T3 | 1 | | | | | | | | | | | | | | | | | | | | | | | | | | | | | | | | | | | | | | |
| 18-5406 | Rotor | 811636, 1 | 1 | | | | | | | | | | | | | | | | | | | | | | | | | | | | | | | | | | | | | | |
|  <p style="text-align: center;">18-5281 TUNE-UP KIT Replaces: 808483Q2 Delco EST - V-8 —CONTAINS—</p> <table border="0"> <thead> <tr> <th>Part #</th> <th>Description</th> <th>O.E. #</th> <th>Qty.</th> </tr> </thead> <tbody> <tr> <td>18-5354</td> <td>Distributor Cap</td> <td>808483</td> <td>1</td> </tr> </tbody> </table> | Part # | Description | O.E. # | Qty. | 18-5354 | Distributor Cap | 808483 | 1 |  <p style="text-align: center;">18-5282 TUNE-UP KIT Holley, Mercury Marine - Single Point V-8</p> |  <p style="text-align: center;">18-5283 TUNE-UP KIT For: Mallory Single Point In-Line 4</p> | | | | | | | | | | | | | | | | | | | | | | | | | | | | | | | |
| Part # | Description | O.E. # | Qty. | | | | | | | | | | | | | | | | | | | | | | | | | | | | | | | | | | | | | | |
| 18-5354 | Distributor Cap | 808483 | 1 | | | | | | | | | | | | | | | | | | | | | | | | | | | | | | | | | | | | | | |
|  <p style="text-align: center;">18-5303 CONTACT SET Replaces: 392-6325, 392-898253005</p> |  <p style="text-align: center;">18-5310 CONTACT SET Replaces: 33700</p> |  <p style="text-align: center;">18-5311 CONTACT SET Replaces: 34235, 34235T</p> |  <p style="text-align: center;">18-5314 CONTACT SET Replaces: 391-5090, 391-898253004</p> | | | | | | | | | | | | | | | | | | | | | | | | | | | | | | | | | | | | | | |

APPLICATION BEGINS ON PAGE 593

| | | | | |
|--|---|---|--|---|
|  <p>18-5317 CONTACT SET Replaces: 64850, 87-71831</p> |  <p>18-5318 CONTACT SET Replaces: 58033, 898253007</p> |  <p>18-5338 CONDENSER Replaces: 391-5092, 391-898253001</p> |  <p>18-5344 CONDENSER Replaces: 33706</p> |  <p>18-5345 CONDENSER Replaces: 33662, 898253003</p> |
|  <p>18-5346 CONDENSER Replaces: 58034, 81-64851</p> |  <p>18-5347 CONDENSER Replaces: 392-6324, 392-898253002</p> |  <p>18-5402 ROTOR Replaces: 898253009 GM V-8 engines w/Delco HEI- 1998 and newer (except MPI engines with 555 ECM)</p> |  <p>18-5245 ROTOR Replaces: 884790, 898253013 For: Late model V-6, V-8 (Alpha/ Bravo 350 Mag, 5.0L, & MX 6.2L)</p> |  <p>18-5403 ROTOR Replaces: 392-9089, 392-9089T, 392-9767</p> |
|  <p>18-5404-1 ROTOR Replaces: 391-7057, 391-5088, 391-7057T, 391-898253029</p> |  <p>18-5405 ROTOR Replaces: 808484, 808484 1, 898253010 Use with 18-5354 Distributor Cap Fits new GM style "Module in Cap" distributors - V-8 application</p> |  <p>18-5406 ROTOR Replaces: 811636, 811636 1, 898253011 Use with 18-5361 Distributor Cap 3.0L LX</p> |  <p>18-5407 ROTOR Replaces: 392-6326, 392-6326T</p> | |
|  <p>18-5408 ROTOR Replaces: 850485, 850485 1, 898253012 Use with 18-5362 Distributor Cap Fits new GM Style "Module in Cap" Distributors V6 Applications</p> |  <p>18-5418 ROTOR Replaces: 58217, 898253008</p> |  <p>18-5420 ROTOR Replaces: 65864, 78016</p> |  <p>18-5431 ROTOR ASSEMBLY Replaces: 13524A5, T1 V-8</p> | |
|  <p>18-5432 ROTOR ASSEMBLY Replaces: 13524A6 V-6</p> |  <p>18-5243 DISTRIBUTOR CAP Replaces: 888731, 898253T23 For: Late model V-6 (4.3L Alpha/Bravo)</p> |  <p>18-5244 DISTRIBUTOR CAP Replaces: 884792, 858253T22 For: Late model V-8 (Alpha/Bravo 350 Mag, 5.0L, & MX 6.2L)</p> |  <p>18-5352 DISTRIBUTOR CAP Replaces: 392-9766, Q1</p> | |

APPLICATION BEGINS ON PAGE 593

MERCURISER

Ignition System



| | | |
|--|--|---|
|  <p>18-5353 DISTRIBUTOR CAP Replaces: 392-9086, 392-9086T</p> |  <p>18-5354 DISTRIBUTOR CAP Replaces: 808483, 808483T3 Fits new GM style "Module in Cap" Distributors-V-8 applications Use 18-5405 Rotor</p> |  <p>18-5361 DISTRIBUTOR CAP Replaces: 811635, 811635T3 Use 18-5406 Rotor 3.0L LX</p> |
|  <p>18-5362 DISTRIBUTOR CAP Replaces: 850484, 850484T, 850484T2 Fits new GM Style "Module in Cap" Distributors - V6 Applications Use 18-5408 Rotor</p> |  <p>18-5369 DISTRIBUTOR CAP Replaces: 392-6318, 392-6318T with gasket 18-5399</p> |  <p>18-5376 DISTRIBUTOR CAP Replaces: 391-5075, 391-5075Q1</p> |
|  <p>18-5380 DISTRIBUTOR CAP Replaces: 16457A4, 805759T1 Premium High Luster Cap</p> |  <p>18-5384 DISTRIBUTOR CAP Replaces: 33708</p> |  <p>18-5385 DISTRIBUTOR CAP Replaces: 393-9459, 393-9459Q1</p> |
|  <p>18-5386 DISTRIBUTOR CAP Replaces: 33765, 33765T</p> |  <p>18-5389 DISTRIBUTOR CAP Replaces: 393-4988T, 393-4988T2</p> |  <p>18-5395 DISTRIBUTOR CAP Replaces: 16457A4, 805759T, 805759T1 V-8</p> |
|  <p>18-5396 DISTRIBUTOR CAP Replaces: 13753A2, 815407A2 V-6</p> |  <p>18-5397 DISTRIBUTOR CAP</p> | <p>PKG OF 2</p>  <p>18-5399 18-5399-9^① DISTRIBUTOR CAP GASKET Replaces: 392-6329</p> |

① Priced per Package

APPLICATION BEGINS ON PAGE 593

FEATURES

- ★ Oil filled for better cooling and long life
- ★ Low resistance and improved turn ratios produces the higher voltage needed to run larger spark plug gaps for added power and better fuel economy
- ★ More windings maximize energy and reliability over the full RPM range
- ★ Fits existing brackets for easy installation

18-5466 HI-PERFORMANCE IGNITION COIL

1.5 ohm (oil filled), black - 8 cylinder:
Flame-Thrower 40,000 volt coil.

- ★ Designed for use with the original Ignitor Electronic Conversion Kits
- ★ Can be used with other inductive ignition systems



18-5469 HI-PERFORMANCE IGNITION COIL

3.0 ohm (oil filled), black - 4 & 6 cylinder:
Flame-Thrower 40,000 volt coil.

- ★ Designed for use with the original Ignitor Electronic Conversion Kits
- ★ Can be used with other inductive ignition systems



18-5472 HI-PERFORMANCE IGNITION COIL

0.6 ohm (oil filled), black - 4, 6, & 8
cylinder:Flame-Thrower 45,000 volt coil.

- ★ Super low 0.6 ohm resistance coil designed for use with the Ignitor II Hi Performance Electronic Conversion Kits
- ★ Compatible with capacitive discharge systems



| Part # | Description | Recommended Coil | Resistance Ohms | Part # | Description | Recommended Coil | Resistance Ohms |
|-----------|--|---------------------|--------------------|---------|--|---------------------|--------------------|
| 18-5294 | Electronic Conversion Kit | 18-5469 | 3.0 | 18-5286 | Hi Performance Electronic Conversion Kit | 18-5472 | 0.6 |
| 18-5295 | Electronic Conversion Kit | 18-5469 | 3.0 | 18-5288 | Hi Performance Electronic Conversion Kit | 18-5472 | 0.6 |
| 18-5296-2 | Electronic Conversion Kit | 18-5466 | 1.5 | 18-5289 | Hi Performance Electronic Conversion Kit | 18-5472 | 0.6 |
| 18-5297 | Electronic Conversion Kit | 18-5469 | 3.0 | 18-5290 | Hi Performance Electronic Conversion Kit | 18-5472 | 0.6 |
| 18-5298 | Electronic Conversion Kit | 18-5466 | 1.5 | 18-5481 | Flame-Thrower Distributor | 18-5472 | 0.6 |
| 18-5299 | Electronic Conversion Kit | 18-5466 | 1.5 | 18-5482 | Flame-Thrower Distributor | 18-5472 | 0.6 |
| 18-5285 | Hi Performance Electronic Conversion Kit | 18-5472 | 0.6 | 18-5483 | Flame-Thrower Distributor | 18-5472 | 0.6 |



① 18-5433D

Display
Package

18-5433 IGNITION COIL

Replaces: 38547, 32193A2,
392-806529A1, 898253T24
DELCO 1115202

(Uses External Resistor)



18-5438 IGNITION COIL

Replaces: 392-7803A4,
392-805570A2
HEI



18-5442 IGNITION COIL

Replaces: 806673T, T1



18-5443 IGNITION COIL

Replaces: 817378T, 817378



18-5117 IGNITION MODULE

Replaces: GM 10482803
Fits: MCM MIE 4.3L MPI, 5.0L MPI, 350
Mag MPI and MX 6.2L MPI engines with
ECM555 (2001 & Up) S/N OM300000 & Up



18-5107-1 IGNITION MODULE

4/6/8 cyl.
Replaces: 811637001



18-5464 IGNITION MODULE

Fits: Sierra 18-5481, 18-5482 and 18-5483
Billet HI-PERFORMANCE ELECTRONIC
DISTRIBUTORS (except HEI/EST)



18-5488 IGNITION MODULE

Replacement module for
Mallory electronic distributors



18-5493 PICK-UP COIL

Replacement pick-up coil for
Accel Electronic Distributors

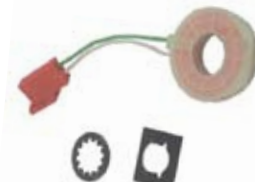

18-5108 PICK UP COIL SENSOR

Replaces: 811639, T
V4/V6/V8



18-5116-1 IGNITION SENSOR KIT

Replaces: 87-861780A2, Q4
For: V-6 & V-8 with Thunderbolt ignition
(1981-1997) nut connectors

APPLICATION BEGINS ON PAGE 593

① Items ending in "D" are Display Packaged - Regular number is Non-Display

Ignitor[®] II

ELECTRONIC IGNITION

FEATURES

- ★ Senses current levels in the coil and adjusts the dwell to maintain peak energy throughout the entire RPM range.
- ★ Develops, on average, 4 times more available energy between 3000 and 5000 RPM's and twice as much plug voltage as point-type systems.
- ★ Ignition energy is sustained and coil life is increased when peak current level is reached just prior to spark.
- ★ More stable timing.
- ★ Use with 18-5472 "Flame Thrower II" Coil for optimum performance

18-5285

HI-PERFORMANCE

ELECTRONIC

CONVERSION KIT

Fits: 4 Cylinder Delco Distributors



18-5286

HI-PERFORMANCE

ELECTRONIC

CONVERSION KIT

Fits: 6 Cylinder Delco Distributors



18-5288

HI-PERFORMANCE

ELECTRONIC

CONVERSION KIT

Fits: Most Prestolite V-8 Distributors with snap down cap



18-5289

HI-PERFORMANCE

ELECTRONIC

CONVERSION KIT

Fits: Most Prestolite Distributors with screw down cap



18-5290

HI-PERFORMANCE

ELECTRONIC

CONVERSION KIT

Fits: Most Mallory YL or YD 8 cylinder Distributors with clockwise and counter clockwise rotation



IGNITOR

ELECTRONIC IGNITION

FEATURES

- ★ Replaces point & condensers for true solid state ignition.
- ★ Uses standard coil, cap and rotor.
- ★ Easy to install, one-piece, 2-wire hook-up.
- ★ Accurate to within 1/4° timing accuracy 0 to 6000 RPM range.
- ★ Can be used with Flame Thrower 18-5466 & 18-5469.

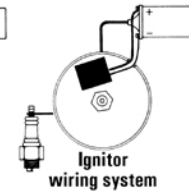
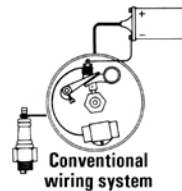

18-5294

ELECTRONIC

CONVERSION KIT

Fits: 6 Cyl. Delco Distributors



18-5295

ELECTRONIC

CONVERSION KIT

Fits: Most 4 Cyl. Prestolite Distributors (Except IBM7026)
For: Onan, Universal, Waukesha, Wisconsin



18-5296-2D

ELECTRONIC

CONVERSION KIT

Fits: Most Mallory YL or YD 8 cyl. Distributors with clockwise or counter clockwise rotation



Display Package

18-5297

ELECTRONIC

CONVERSION KIT

For 4 Cyl. GM



18-5297D Display Package

18-5298

ELECTRONIC

CONVERSION KIT

(with snap down cap) For: Most Prestolite V-8 Distributors



18-5299

ELECTRONIC

CONVERSION KIT

(with screw down cap) For: Most Prestolite V-8 Distributors
Use with 18-5403 Style Rotor



18-5299D Display Package

APPLICATION BEGINS ON PAGE 593

① Items ending in "D" are Display Packaged - Regular number is Non-Display



FEATURES

- ★ *Distributors feature the Ignitor II ignition module with adaptive dwell control adjusts the spark timing over the entire RPM range to maximize performance*
- ★ *Upper roller bearing and oil impregnated bronze sintered bottom bushing are installed and aligned bored for accuracy for maximum durability*
- ★ *Machined heat treated gear with tight tolerances insures durability and consistent timing to maximize horsepower and performance. Complete with high dielectric strength cap and rotor for years of performance*

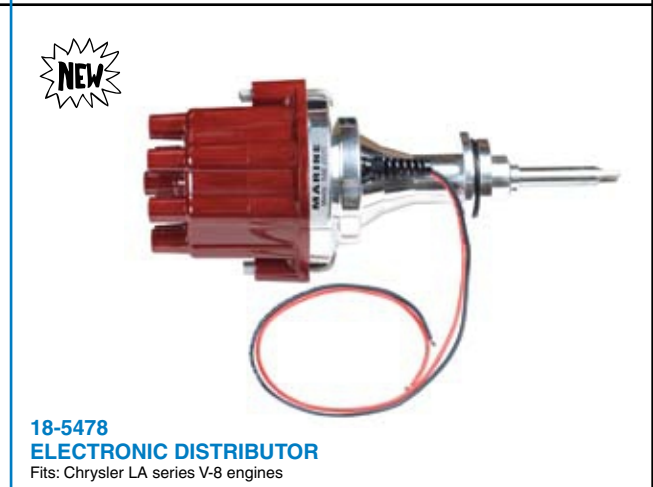
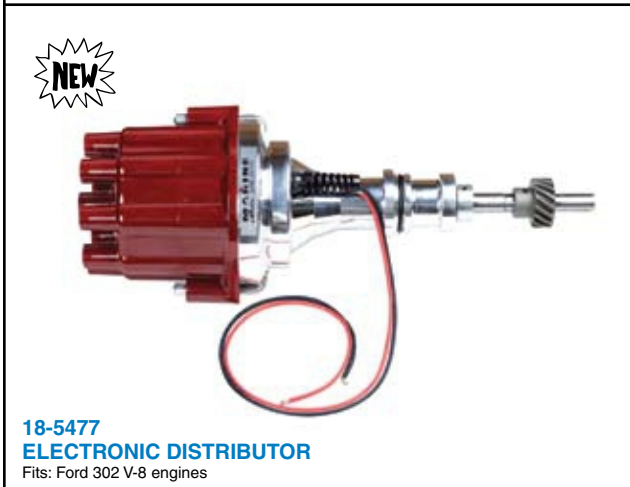
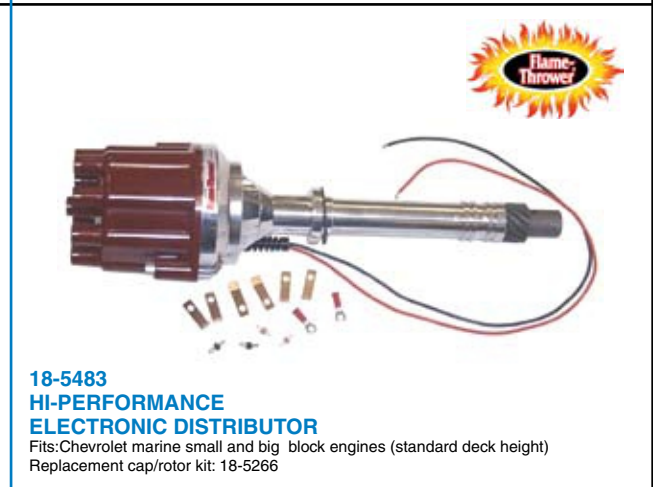
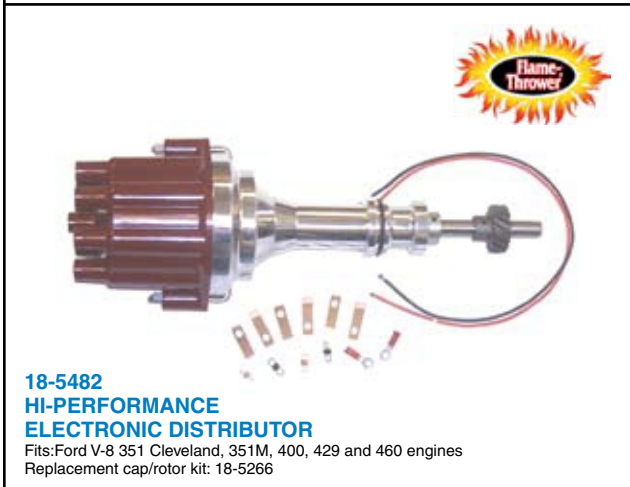
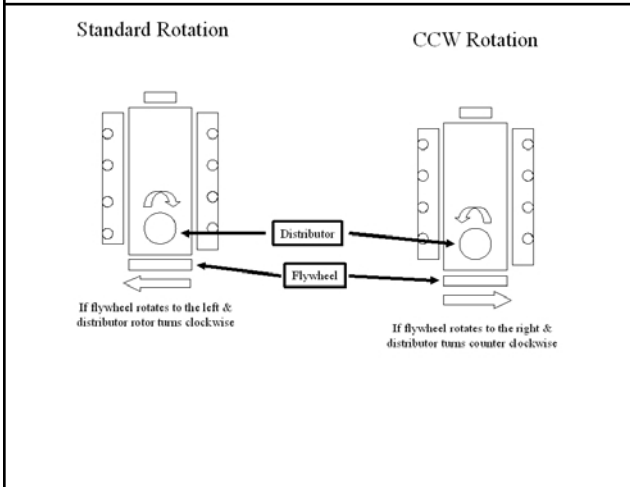

APPLICATION BEGINS ON PAGE 593

MERCUISER

Ignition System



NEW



18-5479
ELECTRONIC DISTRIBUTOR
Fits: GM V-8 engines-reverse rotation



18-5350
DISTRIBUTOR
Replaces: 888751A03
Fits: Vortec™ V-6 4.3L MPI (2002-06)

NEW



18-5351
DISTRIBUTOR
Replaces: 884794A02
Fits: Vortec V-8 2001 and up 5.0L/ 5.7L/ 6.2L MPI engines (S/N OM300000 and up)

NEW



18-5476
DISTRIBUTOR
Replaces: 807964A1
Fits: GM V-6 engines with Delco EST ignition HEI



18-5484
ELECTRONIC DISTRIBUTOR
Left Hand Rotation
Replaces: Mallory YLE624AV
Late Model HEI
For V8 — 262-454 & 502 except 384/ 409 and tall block engines
• Designed as a plug-in replacement for GM-style fuel injection system distributors







| —CONTAINS— | |
|------------|-----------------|
| Part # | Description |
| 18-5354 | Distributor Cap |
| 18-5405 | Rotor |



18-5485
ELECTRONIC DISTRIBUTOR
Right Hand Rotation
Replaces: Mallory YLE624BV
Late Model HEI
For V8 — 262-454 & 502 except 384/ 409 and tall block engines
• Designed as a plug-in replacement for GM-style fuel injection system distributors

| —CONTAINS— | |
|------------|-----------------|
| Part # | Description |
| 18-5354 | Distributor Cap |
| 18-5405 | Rotor |

APPLICATION BEGINS ON PAGE 593

|  <p>18-5486 ELECTRONIC DISTRIBUTOR Conventional Rotation <i>For Chevrolet L4, 153 & 181 CID</i></p> <p>—CONTAINS—</p> <table border="0"> <thead> <tr> <th>Part #</th> <th>Description</th> </tr> </thead> <tbody> <tr> <td>18-5397</td> <td>Distributor Cap</td> </tr> <tr> <td>18-5488</td> <td>Module</td> </tr> <tr> <td>18-5404-1</td> <td>Rotor</td> </tr> </tbody> </table> | Part # | Description | 18-5397 | Distributor Cap | 18-5488 | Module | 18-5404-1 | Rotor |  <p>18-5487 ELECTRONIC DISTRIBUTOR Conventional Rotation <i>For Chevrolet L6, 194, 230, 250, 292 CID</i></p> <p>—CONTAINS—</p> <table border="0"> <thead> <tr> <th>Part #</th> <th>Description</th> </tr> </thead> <tbody> <tr> <td>18-5488</td> <td>Module</td> </tr> <tr> <td>18-5404-1</td> <td>Rotor</td> </tr> </tbody> </table> | Part # | Description | 18-5488 | Module | 18-5404-1 | Rotor | | |
|---|-----------------|-------------|---------|-----------------|---------|--------|-----------|-------|--|--------|-------------|---------|-----------------|-----------|--------|-----------|-------|
| Part # | Description | | | | | | | | | | | | | | | | |
| 18-5397 | Distributor Cap | | | | | | | | | | | | | | | | |
| 18-5488 | Module | | | | | | | | | | | | | | | | |
| 18-5404-1 | Rotor | | | | | | | | | | | | | | | | |
| Part # | Description | | | | | | | | | | | | | | | | |
| 18-5488 | Module | | | | | | | | | | | | | | | | |
| 18-5404-1 | Rotor | | | | | | | | | | | | | | | | |
|  <p>18-5489 ELECTRONIC DISTRIBUTOR Conventional Rotation <i>For Ford V8 351W CID</i></p> <p>—CONTAINS—</p> <table border="0"> <thead> <tr> <th>Part #</th> <th>Description</th> </tr> </thead> <tbody> <tr> <td>18-5376</td> <td>Distributor Cap</td> </tr> <tr> <td>18-5488</td> <td>Module</td> </tr> <tr> <td>18-5404-1</td> <td>Rotor</td> </tr> </tbody> </table> | Part # | Description | 18-5376 | Distributor Cap | 18-5488 | Module | 18-5404-1 | Rotor |  <p>18-5494-1 ELECTRONIC DISTRIBUTOR Conventional Rotation <i>For Chevrolet all V8 includes 482, 502, 540 CID (Except 348,409 & Tall Deck Big Block)</i></p> <p>—CONTAINS—</p> <table border="0"> <thead> <tr> <th>Part #</th> <th>Description</th> </tr> </thead> <tbody> <tr> <td>18-5376</td> <td>Distributor Cap</td> </tr> <tr> <td>18-5488</td> <td>Module</td> </tr> <tr> <td>18-5404-1</td> <td>Rotor</td> </tr> </tbody> </table> | Part # | Description | 18-5376 | Distributor Cap | 18-5488 | Module | 18-5404-1 | Rotor |
| Part # | Description | | | | | | | | | | | | | | | | |
| 18-5376 | Distributor Cap | | | | | | | | | | | | | | | | |
| 18-5488 | Module | | | | | | | | | | | | | | | | |
| 18-5404-1 | Rotor | | | | | | | | | | | | | | | | |
| Part # | Description | | | | | | | | | | | | | | | | |
| 18-5376 | Distributor Cap | | | | | | | | | | | | | | | | |
| 18-5488 | Module | | | | | | | | | | | | | | | | |
| 18-5404-1 | Rotor | | | | | | | | | | | | | | | | |
|  <p>18-5495-1 ELECTRONIC DISTRIBUTOR Conventional Rotation <i>For Ford V8 302 CID</i></p> <p>—CONTAINS—</p> <table border="0"> <thead> <tr> <th>Part #</th> <th>Description</th> </tr> </thead> <tbody> <tr> <td>18-5376</td> <td>Distributor Cap</td> </tr> <tr> <td>18-5488</td> <td>Module</td> </tr> <tr> <td>18-5404-1</td> <td>Rotor</td> </tr> </tbody> </table> | Part # | Description | 18-5376 | Distributor Cap | 18-5488 | Module | 18-5404-1 | Rotor |  <p>18-5496-1 ELECTRONIC DISTRIBUTOR Replaces: YLM567CV Conventional Rotation <i>For Ford V8 351C — 460 CID</i></p> <p>—CONTAINS—</p> <table border="0"> <thead> <tr> <th>Part #</th> <th>Description</th> </tr> </thead> <tbody> <tr> <td>18-5376</td> <td>Distributor Cap</td> </tr> <tr> <td>18-5488</td> <td>Module</td> </tr> <tr> <td>18-5404-1</td> <td>Rotor</td> </tr> </tbody> </table> | Part # | Description | 18-5376 | Distributor Cap | 18-5488 | Module | 18-5404-1 | Rotor |
| Part # | Description | | | | | | | | | | | | | | | | |
| 18-5376 | Distributor Cap | | | | | | | | | | | | | | | | |
| 18-5488 | Module | | | | | | | | | | | | | | | | |
| 18-5404-1 | Rotor | | | | | | | | | | | | | | | | |
| Part # | Description | | | | | | | | | | | | | | | | |
| 18-5376 | Distributor Cap | | | | | | | | | | | | | | | | |
| 18-5488 | Module | | | | | | | | | | | | | | | | |
| 18-5404-1 | Rotor | | | | | | | | | | | | | | | | |

APPLICATION BEGINS ON PAGE 593



**18-5497-1
ELECTRONIC
DISTRIBUTOR**
Replaces: YLM579AV
Conventional Rotation
For Chrysler V8 273,318 (67 & UP) 340,
360 CID "LA" engines

| —CONTAINS— | |
|------------|-----------------|
| Part # | Description |
| 18-5376 | Distributor Cap |
| 18-5488 | Module |
| 18-5404-1 | Rotor |



**18-5498-1
ELECTRONIC
DISTRIBUTOR**
Replaces: YLM624BV
Reverse Rotation
For Chevrolet all V8 includes 482, 502, 540 CID
(Except 348,409 & Tall Deck Big Block)

| —CONTAINS— | |
|------------|-----------------|
| Part # | Description |
| 18-5376 | Distributor Cap |
| 18-5488 | Module |
| 18-5404-1 | Rotor |



**18-5309
DISTRIBUTOR**
Contact Controlled (Standard Rotation)
Replaces: Mallory YL512CV
For most Ford 302 CID V-8 Eng.
Uses: 18-5251 TUNE-UP KIT

| —CONTAINS— | |
|-----------------|-------------|
| Part # | Description |
| 18-5314 | Contact Set |
| 18-5338 | Condenser |
| 18-5404-1 | Rotor |
| And 18-5376 CAP | |



**18-5312
DISTRIBUTOR**
Replaces: Mallory YL554CV
For most Ford 351 CID V-8 Eng.
Uses 18-5251 Tune-Up Kit
& 18-5376 Cap



**18-5313
DISTRIBUTOR**
Contact Controlled (Standard Rotation)
Replaces: 17177A1; Mallory YL624AV
For most GM V-8 Engs. (small & large blocks) Mallory Tall Cap
Uses: 18-5251 TUNE-UP KIT

| —CONTAINS— | |
|-----------------|-------------|
| Part # | Description |
| 18-5314 | Contact Set |
| 18-5338 | Condenser |
| 18-5404-1 | Rotor |
| And 18-5376 CAP | |



**18-5315
DISTRIBUTOR**
Contact Controlled (Standard Rotation)
Replaces: 87581; Mallory YL673AV
For most GM 4 Cyl. Engs. (120 & 140 HP)
Uses: 18-5251 TUNE-UP KIT

| —CONTAINS— | |
|-----------------|-------------|
| Part # | Description |
| 18-5314 | Contact Set |
| 18-5338 | Condenser |
| 18-5404-1 | Rotor |
| And 18-5397 CAP | |



**18-5480
COMPLETE IGNITION
CONVERSION KIT**
Fits: GM SB & BB with Standard Deck Height

| —CONTAINS— | |
|------------|-------------|
| Part # | Description |
| 18-5472 | Coil |
| 18-8803-2 | Wire Set |
| 18-5483 | Distributor |



**18-5779
SWITCH BOX**
Replaces: 332-2986A21,
332-2986A22, 332-2986A25,
332-2986A27

| Model | Beg. S/N | End. S/N |
|--------|----------|----------|
| 225-GM | 2278647 | 2674014 |
| 250-GM | 2314301 | 2639854 |
| 325-GM | 3469128 | & UP |
| 330-GM | 4623115 | & UP |
| 350-GM | 3780450 | & UP |
| 390-GM | 2781129 | 2825059 |

APPLICATION BEGINS ON NEXT PAGE

| Model | CYL | Year | Serial # | Contact Set | Condenser | Rotor | Dist. Cap | Coil | Tune-Up Kit | Distributor | Electronic Conv. Kit | Spark Plug Wires |
|------------------------------|-----|-----------|--|-------------|------------|--------------------|--------------------|--------------------|----------------------|---|----------------------|------------------------|
| 110(153cid) | L4 | 1963-66 | 1537370-2044033 ② | 18-5311 | 18-5345 | 18-5418 | 18-5385 | 18-5433 | 18-5250 18-5268 ⑤ | 18-5315 | 18-5297 | 18-8800-1 |
| 120(153cid) 2.5L | L4 | 1964-89 | 1666601-0C853255 ⑤ ② | 18-5311 | 18-5345 | 18-5418 | 18-5385 | 18-5433 | 18-5250 18-5268 ⑤ | 18-5315 | 18-5297 | 18-8800-1 |
| 140(181cid) 3.0L | L4 | 1968-89 | 2508261-0C856558 ⑤ ② | 18-5311 | 18-5345 | 18-5418 | 18-5385 | 18-5433 | 18-5250 18-5268 ⑤ | 18-5315 | 18-5297 | 18-8800-1 |
| 3.0L/ LX | L4 | 1990-95 | 0C856559 - 0F603999 ② ⑤ | 18-5303 | 18-5347 | 18-5403 | N/A | 18-5433 | 18-5262 | 18-5315 | N/A | 18-8800-1 |
| 3.0L/ LX | L4 | 1990-95 | 0C856559 - 0F603999 ⑦ | N/A | N/A | N/A | N/A | N/A | N/A | N/A | N/A | 18-8811-1 |
| 3.0L/LX | L4 | 1996 & Up | 0F604000 & Up ⑥ | N/A | N/A | 18-5406 | 18-5361 | 18-5443 | 18-5280 | N/A | N/A | 18-8833-1 |
| 140(194cid) | L6 | 1963 | 1538930-1725960 ② | 18-5311 | 18-5345 | 18-5418 | 18-5386 | N/A | 18-5250 18-5269 ⑤ | 18-5312 ⑤ | 18-5294 | 18-8809-1 |
| 150(230cid) | L6 | 1964-66 | 1666495-2048046 ② | 18-5311 | 18-5345 | 18-5418 | 18-5386 | N/A | 18-5250 18-5269 ⑤ | — | 18-5294 | 18-8809-1 |
| 160, 165(250cid) | L6 | 1967-81 | 2048022-5813433 ② | 18-5311 | 18-5345 | 18-5418 | 18-5386 | 18-5433 | 18-5250 18-5269 ⑤ | — | 18-5294 | 18-8809-1 |
| 200(292cid) | L6 | 1969 | 2453769-2712072 ② | 18-5311 | 18-5345 | 18-5418 | 18-5386 | 18-5433 | 18-5250 18-5269 ⑤ | 18-5487 ⑤+ | N/A | 18-8809-1 |
| 470, 485, 488 (224cid) | L4 | 1976-84 | 4208730 - 6916778 ② | 18-5311 | 18-5345 | 18-5418 | 18-5385 | 18-5433 | 18-5250 18-5268 ⑤ | N/A | 18-5297 | 18-8808-2 |
| 165, 170, 190 (224CID) | L4 | 1985-89 | 6916779 & UP ② | 18-5311 | 18-5345 | 18-5418 | 18-5385 | 18-5433 | 18-5250 18-5268 ⑤ | N/A | 18-5297 | 18-8808-2 |
| 180LX | L4 | 1987-89 | 0B436391 & UP ② | 18-5311 | 18-5345 | 18-5418 | 18-5385 | 18-5433 | 18-5250 18-5268 ⑤ | N/A | 18-5297 | 18-8808-2 |
| 180LX | L4 | 1987-89 | 0B436391 & UP ② | 18-5303 | 18-5347 | 18-5403 | N/A | 18-5433 | 18-5262 | N/A | N/A | 18-8808-2 |
| 185(229cid) 4bbl | V6 | 1983-84 | 6330183 - 6919655 ② | 18-5303 | 18-5347 ⑦ | 18-5403 | 18-5353 | 18-5433 | 18-5262 18-5276 ⑤ | N/A | N/A | 18-8801-1 |
| 175, 185, 4.3 (262cid) 2bbl | V6 | 1985-93 | 6919656-0F000877 ⑩ | N/A | N/A | 18-5432 | 18-5396 | 18-5438* | 18-5274 | N/A | N/A | 18-8810-1 |
| 205, 4.3LX (262cid) 4bbl | V6 | 1985-96 | 0A331455-0F802999 ⑩ | N/A | N/A | 18-5432 | 18-5396 | 18-5438* | 18-5274 | N/A | N/A | 18-8810-1 |
| 4.3L/LH/LX/LXH Alpha(Gen+) | V6 | 1996-2001 | 0F803000 & UP ⑩ | N/A | N/A | 18-5432 | 18-5396 | 18-5438* | 18-5274 | N/A | N/A | 18-8810-1 |
| 4.3L/LH/LX/LXH Bravo(Gen+) | V6 | 1996-2001 | 0F803000 & UP ⑩ | N/A | N/A | 18-5432 | 18-5396 | 18-5438* | 18-5274 | N/A | N/A | 18-8810-1 |
| 4.3L EFI,262 Mag(TBI)(Gen+) | V6 | 1996-98 | 0F803000- 0L359999 ⑥ | N/A | N/A | 18-5408 | 18-5362 | 18-5443 | 18-5278 | N/A | N/A | 18-8810-1 |
| 4.3L EFI(TBI)(Gen+) | V6 | 1996 & up | OL102009-OL359999 ② ★ ⚡ ☆ OL360000 & up ② ★ ⚡ ☆ | N/A N/A | N/A N/A | 18-5408 18-5432 | 18-5362 18-5396 | 18-5443 18-5438 | 18-5278 18-5274 | 18-5476 N/A | N/A N/A | 18-8835-1 18-8835-1 |
| 4.3L EFI(TBI)(Gen+) | V6 | 1999-2001 | 0I360000 & UP ⑩ | N/A | N/A | 18-5432 | 18-5396 | 18-5438* | 18-5274 | N/A | N/A | 18-8810-1 |
| 190GM(283cid) | V8 | 1963-64 | 1564539-1730903 ② | 18-5310 | 18-5344 | 18-5417 | 18-5384 | 18-5438* | 18-5252 | 18-5498-1 ⑤+ 18-5494-1 ⑤+ 18-5313 ⑤ | N/A | 18-8803-2 |
| 4.3L MPI | V6 | 2001 & up | OM300000 & up | N/A | N/A | 18-5245 | 18-5243 | N/A | 18-5246 | 18-5350 | N/A | 18-8829-1 |
| 215 MCM & MIE Ford(302cid) | V8 | 1970-72 | 2781153-3563181 ③ | 18-5318 | 18-5346 | 18-5402 | 18-5389 | 18-5433 | 18-5253 18-5267 ⑤ | 18-5495-1 ⑤+ 18-5309 ⑤ | N/A | 18-8803-2 |
| 215 MCM & MIE Ford(302cid) | V8 | 1970-72 | 2781153-3563181 ① | 18-5314 | 18-5338 | 18-5404-1 | 18-5376 | 18-5433 | 18-5251 18-5271 ⑤ | 18-5495-1 ⑤ 18-5309 ⑤ | 18-5296-2 | 18-8803-2 |
| 225 MCM & MIE Ford(302cid) | V8 | 1973-74 | 3385721-4166999 ③ | 18-5318 | 18-5346 | 18-5420 | 18-5389 | 18-5433 | 18-5253 18-5267 ⑤ | 18-5495-1 ⑤+ 18-5309 ⑤ | N/A | 18-8803-2 |
| 225 MCM & MIE Ford(302cid) | V8 | 1973-74 | 3385721-4166999 ① | 18-5314 | 18-5338 | 18-5404-1 | 18-5376 | 18-5433 | 18-5251 18-5271 ⑤ | 18-5495-1 ⑤ 18-5309 ⑤ | 18-5296-2 | 18-8803-2 |
| 225 MCM & MIE Ford(302cid) | V8 | 1973-74 | 3385721-4166999 ④ | 18-5317 | 18-5346 | 18-5420 | 18-5389 | 18-5433 | 18-5254 18-5267 ⑤ | 18-5495-1 ⑤+ 18-5309 ⑤ | N/A | 18-8803-2 |
| 233 MCM & MIE Ford(351w cid) | V8 | 1975-77 | 4173000-4902304 ②⑧ | 18-5303 | 18-5347 ⑦ | 18-5409 | 18-5352 | 18-5433 | 18-5260 18-5275 ⑤ | 18-5489 18-5312 ⑤ | 18-5299 | 18-8803-2 |
| 233 MCM & MIE Ford(351w cid) | V8 | 1975-77 | 4173000-4902304 ② | 18-5303 | 18-5347 ⑦ | 18-5407 | 18-5369 | 18-5433 | 18-5258 18-5277 ⑤ | 18-5489 18-5312 ⑤ | 18-5298 | 18-8803-2 |
| 233 MCM & MIE Ford(351w cid) | V8 | 1975-77 | 4173000-4902304 ④ | 18-5317 | 18-5346 | 18-5420 | 18-5389 | 18-5433 | 18-5254 | 18-5489 ⑤+ 18-5312 ⑤ | N/A | 18-8803-2 |
| 888, 188 Ford (302cid) | V8 | 1971-77 | 3108723-4887829 ④ | 18-5317 | 18-5346 | 18-5420 | 18-5389 | 18-5433 | 18-5254 | 18-5495-1 ⑤+ 18-5309 ⑤ | N/A | 18-8803-2 |
| 888, 188 Ford (302cid) | V8 | 1971-77 | 3108723-4887829 ③ | 18-5318 | 18-5346 | 18-5420 | 18-5389 | 18-5433 | 18-5253 18-5267 ⑤ | 18-5495-1 ⑤+ 18-5309 ⑤ | N/A | 18-8803-2 |
| 888, 188 Ford (302cid) | V8 | 1971-77 | 3108723-4887829 ② | 18-5303 | 18-5347 ⑦ | 18-5407 | 18-5369 | 18-5433 | 18-5258 18-5277 ⑤ | 18-5495-1 ⑤ 18-5309 ⑤ | 18-5298 | 18-8803-2 |
| 888, 188 Ford (302cid) | V8 | 1971-77 | 3108723-4887829 ① | 18-5314 | 18-5338 | 18-5404-1 | 18-5376 | 18-5433 | 18-5251 18-5271 ⑤ | 18-5495-1 ⑤ 18-5309 ⑤ | 18-5296-2 | 18-8803-2 |
| 255 MCM & MIE Ford(351w cid) | V8 | 1973-74 | 3385721-4166999 ④ | 18-5317 | 18-5346 | 18-5420 | 18-5389 | 18-5433 | 18-5254 | 18-5489 ⑤+ 18-5312 ⑤ | N/A | 18-8803-2 |

NA Not applicable Ⓜ Thunderbolt
NLA No longer available Ⓨ For wire type lead use
 ① Mallory Ignition Ⓩ With screw-down cap
 ② Prestolite ⓐ With conventional ign.
 ③ Autolite Ignition ⓑ Thunderbolt IV
 ④ Mercury Ignition ⓓ With copper connector
 ⑤ Holley ⓔ Delco
 ⚡ When replacing an HEI System with an Electronic Distributor- the amplifier must be removed; the coil changed; and the plug wires may need to be changed out
 Ⓜ Electronic dist. (std. Rotation) excl. Thunderbolt ign.
 Ⓨ Mercury Ign.
 ⓐ Contact controlled dist. (std. Rotation) excl. Thunderbolt ign.
 ⓑ Delco EST system
 ⓓ Delco digital system
 ⓔ With dist. cap
 ⓕ Distributor mounted ignition amplifier
 ⓖ Mercury HEI
 ⓗ Distributorless Ignition
 ⓘ These coils are the old standard series, not the current upgrade kit
 ⓙ Thunderbolt IV(1) System
 ⓚ Thunderbolt V Ignition
 ⓛ Thunderbolt IV(2) System



MERCUISER Ignition System



| Model | CYL | Year | Serial # | Contact Set | Condenser | Rotor | Dist. Cap | Coil | Tune-Up Kit | Distributor | Electronic Conv. Kit | Spark Plug Wires |
|---|-----|-----------|---------------------|-------------|-----------|-----------|-----------|----------|----------------------|---|----------------------|------------------|
| 255 MCM & MIE Ford(351w cid) | V8 | 1973-74 | 3385721-4166999 ① | 18-5314 | 18-5338 | 18-5404-1 | 18-5376 | 18-5433 | 18-5251 18-5271 ② | 18-5489 ③ 18-5312 ⑤ | 18-5296-2 | 18-8803-2 |
| 198, 898 MCM & MIE GM(305cid) | V8 | 1977-82 | 4776402-6218461 ① | 18-5314 | 18-5338 | 18-5404-1 | 18-5376 | 18-5433 | 18-5251 18-5271 ② | 18-5494-1 ③ 18-5498-1 ④ 18-5313 ⑤ | 18-5296-2 | 18-8803-2 |
| 198, 898, 5.0L GM (305cid) | V8 | 1983-84 | 6218462-6899057 ⑩ | N/A | N/A | 18-5431 | 18-5395 | 18-5438* | 18-5273 ② | 18-5494-1 ③ 18-5498-1 ④ | N/A | 18-8804-1 |
| 200, 5.0L GM (305cid) | V8 | 1985-95 | 6218462 - F600999 ⑩ | N/A | N/A | 18-5431 | 18-5395 | 18-5438* | 18-5273 ② | 18-5494-1 ③ 18-5498-1 ④ | N/A | 18-8804-1 |
| 200, 5.0L GM (305cid) | V8 | 1987-95 | 0B525982-0F600999 ★ | N/A | N/A | 18-5431 | 18-5395 | 18-5438* | 18-5273 ② | 18-5494-1 ③ 18-5498-1 ④ | N/A | 18-8804-1 |
| 225 MCM GM (327cid) | V8 | 1963-69 | 1539620-2694014 ② | 18-5310 | 18-5344 | 18-5417 | 18-5384 | 18-5433 | 18-5252 18-5270 ② | 18-5494-1 ③ 18-5498-1 ④ 18-5313 ⑤ | N/A | 18-8803-2 |
| 225 INB GM (327cid) | V8 | 1968 | 2278647-2694014 ⑥ | N/A | N/A | 18-5420 | 18-5389 | N/A | 18-5282 | 18-5494-1 ③ 18-5498-1 ④ 18-5313 ⑤ | N/A | 18-8803-2 |
| 228 MCM & MIE GM(305cid) | V8 | 1977-84 | 4765100 - 6218461 ① | 18-5314 | 18-5338 | 18-5404-1 | 18-5376 | 18-5433 | 18-5251 18-5271 ② | 18-5494-1 ③ 18-5498-1 ④ 18-5313 ⑤ | 18-5296-2 | 18-8803-2 |
| 228GM(305cid) | V8 | 1985-86 | 6218462-6899268 ⑩ | N/A | N/A | 18-5431 | 18-5395 | 18-5438* | 18-5273 ② | 18-5494-1 ③ 18-5498-1 ④ | N/A | 18-8804-1 |
| 230, 5.0L/LX MIE (305cid) | V8 | 1981-95 | 5907058-0F600999 ⑩★ | N/A | N/A | 18-5431 | 18-5395 | 18-5438* | 18-5273 ② | 18-5494-1 ③ 18-5498-1 ④ | N/A | 18-8804-1 |
| 5.0L Alpha & Bravo(Gen+) | V8 | 1998-2001 | 0L015751 & up ★ | N/A | N/A | 18-5431 | 18-5395 | 18-5438* | 18-5273 ② | 18-5494-1 ③ 18-5498-1 ④ | N/A | 18-8821-1 |
| 5.0L EFI(Gen+) | V8 | 1998 | 0L012502-0L339999 ② | N/A | N/A | 18-5405 | 18-5354 | 18-5442 | 18-5281 | 18-5494-1 ③ 18-5498-1 ④ | N/A | 18-8836-1 |
| 5.0L EFI (Gen +) | V8 | 1999-2001 | 0L331631 & up ④ | N/A | N/A | 18-5431 | 18-5395 | 18-5438* | 18-5273 ② | 18-5494-1 ③ 18-5498-1 ④ | N/A | 18-8834-1 |
| 5.0L MCM/MIE MPI, 350 Mag MPI & MX, 6.2L MPI w/ECM555 | V8 | 2001 & up | OM300000 & up | N/A | N/A | 18-5245 | 18-5244 | N/A | 18-5247 | 18-5351 | N/A | 18-8828-1 |
| 250MCM & MIE GM(327cid) | V8 | 1968-69 | 2314301-2639854 ⑥ | N/A | N/A | 18-5420 | 18-5389 | N/A | 18-5282 | 18-5494-1 ③ 18-5498-1 ④ 18-5313 ⑤ | N/A | 18-8803-2 |
| 250GM(350cid) | V8 | 1977 | 4768000 - 4908849 ① | 18-5314 | 18-5338 | 18-5404-1 | 18-5376 | 18-5433 | 18-5251 18-5271 ② | 18-5494-1 ③ 18-5498-1 ④ 18-5313 ⑤ | 18-5296-2 | 18-8803-2 |
| 255, 260MCM & MIE(350cid) | V8 | 1975-1982 | 3258728-6218461 ① | 18-5314 | 18-5338 | 18-5404-1 | 18-5376 | 18-5433 | 18-5251 18-5271 ② | 18-5494-1 ③ 18-5498-1 ④ 18-5313 ⑤ | 18-5296-2 | 18-8803-2 |
| 255MCM & MIE (350cid) | V8 | 1975-80 | 4498701-5907057 ④ | 18-5317 | 18-5346 | 18-5420 | 18-5389 | 18-5433 | 18-5254 | 18-5494-1 ③ 18-5498-1 ④ 18-5313 ⑤ | N/A | 18-8803-2 |
| 260,350MAG, 5.7L MCM & MIE [LH](350cid) | V8 | 1982-1994 | 6218462- 0F600999 ⑩ | N/A | N/A | 18-5431 | 18-5395 | 18-5438* | 18-5273 ② | 18-5494-1 ③ 18-5498-1 ④ | N/A | 18-8804-1 |
| 260, 350MAG, 5.7L SKI/ ALPHA/ BRAVO(350cid) | V8 | 1987-95 | 0B525982-0F600999 ★ | N/A | N/A | 18-5431 | 18-5395 | 18-5438* | 18-5273 ② | 18-5494-1 ③ 18-5498-1 ④ | N/A | 18-8804-1 |
| 260, 350MAG, 5.7L ALPHA/ BRAVO(350cid) | V8 | 1987-95 | 0B525982-0F600999 ★ | N/A | N/A | 18-5431 | 18-5395 | 18-5438* | 18-5273 ② | 18-5494-1 ③ 18-5498-1 ④ | N/A | 18-8821-1 |
| 350MAG, 5.7L/ LX ALPHA & BRAVO + (Gen+) | V8 | 1994-2001 | 0F353525 & up ② | N/A | N/A | 18-5431 | 18-5395 | 18-5438* | 18-5273 ② | 18-5494-1 ③ 18-5498-1 ④ | N/A | 18-8821-1 |
| 5.7L EFI & (Gen+) | V8 | 1995-98 | 0F225560-0L339999 ② | N/A | N/A | 18-5405 | 18-5354 | 18-5442 | 18-5281 | 18-5494-1 ③ 18-5498-1 ④ | N/A | 18-8836-1 |
| 5.7L EFI & (Gen+) | V8 | 1999-2001 | 0L325977 & up ⑩ | N/A | N/A | 18-5431 | 18-5395 | 18-5438 | 18-5273 ② | 18-5494-1 ③ 18-5498-1 ④ | N/A | 18-8834-1 |
| 5.7L SKI | V8 | 1985-95 | 0A338533-0F775199 ① | 18-5314 | 18-5338 | 18-5404-1 | 18-5376 | 18-5433 | 18-5251 18-5271 ② | 18-5494-1 ③ 18-5498-1 ④ 18-5313 ⑤ | 18-5296-2 | 18-8802-1 |
| 5.7L SKI | V8 | 1985-95 | 0A338533-0F775199 ② | 18-5303 | 18-5347 | 18-5403 | 18-5352 | 18-5433 | 18-5262 18-5275 ② | 18-5494-1 ③ 18-5498-1 ④ 18-5313 ⑤ | 18-5299 | 18-8802-1 |
| 5.7L SKI | V8 | 1987-97 | 0B514627-0K999999 ⑩ | N/A | N/A | 18-5431 | 18-5395 | 18-5438* | 18-5273 ② | 18-5494-1 ③ | N/A | 18-8821-1 |

NA Not applicable ⑥ Thunderbolt ② Electronic dist. (std. Rotation) excl. Thunderbolt ign. ② Mercury HEI
NLA No longer available ⑦ For wire type lead use ③ Mercury Ign. → Distributorless Ignition
 ① Mallory Ignition ⑧ With screw-down cap ④ Contact controlled dist. (std. Rotation) excl. Thunderbolt ign. * These coils are the old standard series, not the current upgrade kit
 ② Prestolite ⑨ With conventional ign. ⑤ Delco EST system * Thunderbolt IV(1) System
 ③ Autolite Ignition ⑩ Thunderbolt IV ⑥ Delco digital system ⚡ Thunderbolt V Ignition
 ④ Mercury Ignition ⑪ With copper connector ⑦ With dist. cap * Thunderbolt IV(2) System
 ⑤ Holley ⑫ Delco ⑧ Distributor mounted ignition amplifier

✦ When replacing an HEI System with an Electronic Distributor- the amplifier must be removed; the coil changed; and the plug wires may need to be changed out

| Model | CYL | Year | Serial # | Contact Set | Condenser | Rotor | Dist. Cap | Coil | Tune-Up Kit | Distributor | Electronic Conv. Kit | Spark Plug Wires |
|-----------------------------------|-----|-----------|---------------------|-------------|-----------|-----------|-----------|----------|----------------------|--|----------------------|------------------|
| 5.7L SKI | V8 | 1987-95 | 0B514627-0F775199 * | N/A | N/A | 18-5431 | 18-5395 | 18-5433 | 18-5273 ⑥ | 18-5498-1 ④✚ 18-5494-1 ④✚ 18-5498-1 ④✚ | N/A | 18-8821-1 |
| 5.7L SKI | V8 | 1998-2001 | 0L002005 & up ⑩ | N/A | N/A | 18-5431 | 18-5395 | 18-5438* | 18-5273 ⑥ | 18-5494-1 ④✚ 18-5498-1 ④✚ | N/A | 18-8821-1 |
| 5.7L MIE & SKI | V8 | 1998 & up | 0L002003 & up | N/A | N/A | 18-5431 | 18-5395 | 18-5438 | 18-5273 | N/A | N/A | 18-8830-1 |
| 5.7LX & BRAVO EFI + (Gen+) | V8 | 1996-2001 | 0F752400-0K999999 ⑩ | N/A | N/A | 18-5405 | 18-5354 | 18-5442 | 18-5281 | 18-5494-1 ④✚ 18-5498-1 ④✚ | N/A | 18-8836-1 |
| 350 MAG ALPHA EFI(Gen+) | V8 | 1996-97 | 0F800300-0K999999 ② | N/A | N/A | 18-5405 | 18-5354 | 18-5442 | 18-5281 | 18-5494-1 ④✚ 18-5498-1 ④✚ | N/A | 18-8836-1 |
| 350MAG BRAVO MPI & (Gen+) | V8 | 1995-98 | 0F415189-0L325952 ② | N/A | N/A | 18-5405 | 18-5354 | 18-5443 | 18-5281 | 18-5494-1 ④✚ 18-5498-1 ④✚ | N/A | 18-8836-1 |
| 350MAG MPI MIE (Gen+) | V8 | 1998 | 0L002008-0L302199 ② | N/A | N/A | 18-5405 | 18-5354 | 18-5443 | 18-5281 | 18-5494-1 ④✚ 18-5498-1 ④✚ | N/A | 18-8832-1 |
| 350MAG MPI MIE (Gen+) | V8 | 1998-2001 | 0L302200-OM299999 ④ | N/A | N/A | 18-5431 | 18-5395 | 18-5438 | 18-5273 | N/A | NA | 18-8834-1 |
| 350 MAG MPI MIE | V8 | 2001 & Up | OM300000 & Up | N/A | N/A | 18-5245 | 18-5244 | N/A | 18-5247 | N/A | NA | 18-8828-1 |
| 350MAG EFI SKI | V8 | 1994-96 | 0F215561-0F820706 ② | N/A | N/A | 18-5405 | 18-5354 | 18-5442 | 18-5281 | 18-5494-1 ④✚ 18-5498-1 ④✚ | N/A | 18-8832-1 |
| 350MAG EFI SKI & (Gen+) | V8 | 1996-97 | 0F820707-0K999999 ② | N/A | N/A | 18-5405 | 18-5354 | 18-5443 | 18-5281 | 18-5494-1 ④✚ 18-5498-1 ④✚ | N/A | 18-8832-1 |
| 350MAG MPI SKI & (Gen+) | V8 | 1995-98 | 0F350583-0L304599 ② | N/A | N/A | 18-5405 | 18-5354 | 18-5443 | 18-5281 | 18-5494-1 ④✚ 18-5498-1 ④✚ | N/A | 18-8836-1 |
| BLACK SCORPION SKI(Gen+) (350cid) | V8 | 1996 | 0F800000-0K040000 ② | N/A | N/A | 18-5405 | 18-5354 | 18-5443 | 18-5281 | 18-5494-1 ④✚ 18-5498-1 ④✚ | N/A | 18-8832-1 |
| BLACK SCORPION SKI(Gen+) (350cid) | V8 | 1997-98 | 0K040001-0L005600 ② | N/A | N/A | 18-5405 | 18-5354 | 18-5443 | 18-5281 | 18-5494-1 ④✚ 18-5498-1 ④✚ | N/A | 18-8824-1 |
| BLACK SCORPION SKI(Gen+) (350cid) | V8 | 1998-2002 | 0L005601-OM391599 ② | N/A | N/A | 18-5405 | 18-5354 | 18-5443 | 18-5281 | 18-5494-1 ④✚ 18-5498-1 ④✚ | N/A | 18-8822-1 |
| 350MAG MPI (Gen+) & MIE(Gen+) | V8 | 1998-2001 | 0L302200 & up ⑩ | N/A | N/A | 18-5431 | 18-5395 | 18-5438* | 18-5273 ⑥ | 18-5494-1 ④✚ 18-5498-1 ④✚ | N/A | 18-8834-1 |
| 350 MAG MPI | V8 | 2001-2004 | OM300000 & Up ⑩ | N/A | N/A | 18-5245 | 18-5244 | NA | 18-5247 | 18-5351 | NA | 18-8828-1 |
| 350 MAG MPI HORIZON | | | | N/A | N/A | 18-5245 | 18-5244 | NA | 18-5247 | NA | NA | 18-8828-1 |
| 350 MAG HORIZON MIE | V8 | 1999-2001 | 0L304700 & up ⑩ | N/A | N/A | 18-5431 | 18-5395 | 18-5438* | 18-5273 ⑥ | 18-5494-1 ④✚ 18-5498-1 ④✚ | N/A | 18-8834-1 |
| 350 MAG HORIZON MIE | V8 | 2001-2004 | OM300000 & Up ⑩ | N/A | N/A | 18-5245 | 18-5244 | NA | 18-5247 | 18-5351 | N/A | 18-8828-1 |
| 350MAG MPI SKI(Gen+) | V8 | 1999-2001 | 0L304600 & up ⑩ | N/A | N/A | 18-5431 | 18-5395 | 18-5438* | 18-5273 ⑥ | 18-5494-1 ④✚ 18-5498-1 ④✚ | N/A | 18-8834-1 |
| 350MAG SKI | V8 | 1991-96 | OD505450-0K040399★ | N/A | N/A | 18-5431 | 18-5395 | 18-5438* | 18-5273 ⑥ | 18-5494-1 ④✚ 18-5498-1 ④✚ | N/A | 18-8804-1 |
| 350MAG SKI | V8 | 1991-96 | OD505450-0K040399★ | N/A | N/A | 18-5431 | 18-5395 | 18-5438* | 18-5273 ⑥ | 18-5494-1 ④✚ 18-5498-1 ④✚ | N/A | 18-8821-1 |
| 350MAG SKI | V8 | 1991-97 | OD505450-0K999999 ③ | N/A | N/A | 18-5431 | 18-5395 | 18-5438* | 18-5273 ⑥ | 18-5494-1 ④✚ 18-5498-1 ④✚ | N/A | 18-8821-1 |
| 270MCM & MIE (350cid) | V8 | 1969-72 | 2851074-3385720 ⑥ | N/A | N/A | 18-5420 | 18-5389 | N/A | 18-5282 | 18-5494-1 ④✚ 18-5498-1 ④✚ | N/A | 18-8803-2 |
| 280 TRS(350cid) | V8 | 1975 | 4176250-4499390 ④ | 18-5317 | 18-5436 | 18-5420 | 18-5389 | 18-5433 | 18-5282 | 18-5494-1 ④✚ 18-5498-1 ④✚ 18-5313 ⑤ | N/A | 18-8803-2 |
| 280 TRS(350cid) | V8 | 1976 | 4499391-4770199 ① | 18-5314 | 18-5338 | 18-5404-1 | 18-5376 | 18-5433 | 18-5251 18-5271 ⑥ | 18-5494-1 ④✚ 18-5498-1 ④✚ 18-5313 ⑤ | 18-5296-2 | 18-8803-2 |
| 300, 320EFI (350cid) | V8 | 1985-89 | 0A543604-0C622418 ⑩ | N/A | N/A | 18-5431 | 18-5395 | 18-5438* | 18-5273 ⑥ | 18-5494-1 ④✚ 18-5498-1 ④✚ | N/A | 18-8804-1 |
| 377 SCORPION MCM(377cid) | V8 | 1999-2000 | 0L416146 & up ② | N/A | N/A | 18-5405 | 18-5354 | 18-5443 | 18-5281 | 18-5494-1 ④✚ 18-5498-1 ④✚ | N/A | N/A |
| 377 SCORPION SKI(377cid) | V8 | 1997-98 | 0K000656 & up ② | N/A | N/A | 18-5405 | 18-5354 | 18-5443 | 18-5281 | 18-5494-1 ④✚ 18-5498-1 ④✚ | N/A | N/A |
| MX 6.2L MPI (377cid) | V8 | 2000-2001 | 0L680003 & up ⑩ | N/A | N/A | 18-5431 | 18-5395 | 18-5438* | 18-5273 ⑥ | 18-5494-1 ④✚ 18-5498-1 ④✚ | N/A | 18-8834-1 |
| MX 6.2L MPI (377CID) | V8 | 2001-2004 | OM300000 & Up ⑩ | N/A | N/A | 18-5245 | 18-5244 | NA | 18-5247 | NA | N/A | 18-8828-1 |
| MX 6.2L MPI HORIZON (377CID) | V8 | 2001-2004 | OM300000 & Up ⑩ | N/A | N/A | 18-5245 | 18-5244 | NA | 18-5247 | 18-5351 | N/A | 18-8828-1 |
| MX 6.2L MPI HORIZONMIE (377CID) | V8 | 2001-2004 | OM300000 & Up ⑩ | N/A | N/A | 18-5245 | 18-5244 | NA | 18-5247 | 18-5351 | N/A | 18-8828-1 |
| MX 6.2L MPI MIE | V8 | 2001-2004 | OM300000 & Up ⑩ | N/A | N/A | 18-5245 | 18-5244 | NA | 18-5247 | 18-5351 | N/A | 18-8828-1 |

NA Not applicable ⑥ Thunderbolt ④ Electronic dist. (std. Rotation) excl. Thunderbolt ign. ⑩ Mercury HEI

NLA No longer available ⑦ For wire type lead use ⑤ Mercury Ign. → Distributorless Ignition

① Mallory Ignition ⑧ With screw-down cap ⑥ Contact controlled dist. (std. Rotation) excl. Thunderbolt ign. * These coils are the old standard series, not the current upgrade kit

② Prestolite ⑨ With conventional ign. ⑦ Delco EST system ✱ Thunderbolt IV(1) System

③ Autolite Ignition ⑩ Thunderbolt IV ⑧ Delco digital system ✱ Thunderbolt V Ignition

④ Mercury Ignition ⑪ With copper connector ⑨ With dist. cap ✱ Thunderbolt IV(2) System

⑤ Holley ⑫ Delco ⑩ Distributor mounted ignition amplifier

✚ When replacing an HEI System with an Electronic Distributor- the amplifier must be removed; the coil changed; and the plug wires may need to be changed out



MERCUISER

Ignition System



| Model | CYL | Year | Serial # | Contact Set | Condenser | Rotor | Dist. Cap | Coil | Tune-Up Kit | Distributor | Electronic Conv. Kit | Spark Plug Wires |
|--------------------------------------|-----|-----------|------------------------|-------------|-----------|-----------|-----------|----------|----------------------|---|----------------------|------------------|
| (377CID) MX 6.2L MPI SKI (377CID) | V8 | 2002-2004 | OM317000 & Up ⑩ | N/A | N/A | 18-5245 | 18-5244 | NA | 18-5247 | NA | N/A | 18-8828-1 |
| 325 MCM & MIE (427cid) | V8 | 1969-1974 | 2278747 & up ⑥ | N/A | N/A | 18-5420 | 18-5389 | N/A | 18-5282 | 18-5494-1 ④⊕ 18-5498-1 ④⊕ | N/A | 18-8803-2 |
| 330 MCM & MIE (454cid) | V8 | 1977-81 | 4623115-6083144 ① | 18-5314 | 18-5338 | 18-5404-1 | 18-5376 | 18-5433 | 18-5251 18-5271 ⑥ | 18-5494-1 ④ 18-5498-1 ④ 18-5313 ⑤ | 18-5296-2 | 18-8803-2 |
| 330 MCM & MIE (454cid) | V8 | 1977-81 | 4623115-6083144 ⑥ | N/A | N/A | 18-5420 | 18-5389 | N/A | 18-5282 | 18-5494-1 ④⊕ 18-5498-1 ④⊕ 18-5313 ⑤ | N/A | 18-8803-2 |
| 330, 340, 7.4L MCM & MIE(454cid) | V8 | 1981-92 | 5889914-0D715493 ⑩ | N/A | N/A | 18-5431 | 18-5395 | 18-5438* | 18-5273 ⑥ | 18-5494-1 ④⊕ 18-5498-1 ④⊕ | N/A | 18-8804-1 |
| 350 MIE(454cid) | V8 | 1974-76 | 3780450-4623109 ⑥ | N/A | N/A | 18-5420 | 18-5389 | N/A | 18-5282 | 18-5494-1 ④⊕ 18-5498-1 ④⊕ | N/A | 18-8803-2 |
| 370, 400, 440TRS (454cid) | V8 | 1978-85 | 4179554-6721527 ① | 18-5314 | 18-5338 | 18-5404-1 | 18-5376 | 18-5433 | 18-5251 18-5271 ⑥ | 18-5494-1 ④ 18-5498-1 ④ 18-5313 ⑤ | 18-5296-2 | 18-8803-2 |
| 370, 400, 440 TRS (454cid) | V8 | 1978-85 | 4883520-6721527 ⑤ | 18-5317 | 18-5346 | 18-5420 | 18-5389 | 18-5433 | 18-5254 | 18-5494-1 ④⊕ 18-5498-1 ④⊕ 18-5313 ⑤ | N/A | 18-8803-2 |
| 370 TRS(454cid) | V8 | 1985-87 | 6721528-0B714586 ⑩ | N/A | N/A | 18-5431 | 18-5395 | 18-5433 | 18-5273 ⑥ | 18-5494-1 ④⊕ 18-5498-1 ④⊕ | N/A | 18-8804-1 |
| 420, 425(454cid) | V8 | 1987-93 | 0A398941-0D937011 ⑩ | N/A | N/A | 18-5431 | 18-5395 | 18-5438* | 18-5273 ⑥ | 18-5494-1 ④⊕ 18-5498-1 ④⊕ | N/A | 18-8837-1 |
| 450(454cid) | V8 | 1995-96 | 0F347100-0F347277 ⑩ | N/A | N/A | 18-5431 | 18-5395 | 18-5438* | 18-5273 ⑥ | 18-5494-1 ④⊕ 18-5498-1 ④⊕ | N/A | 18-8804-1 |
| 454 MAG ALPHA/ BRAVO | V8 | 1986-97 | 0A631894-OK999999 ⑩*★⊕ | N/A | N/A | 18-5431 | 18-5395 | 18-5438* | 18-5273 ⑥ | 18-5494-1 ④⊕ 18-5498-1 ④⊕ | N/A | 18-8804-1 |
| 454-EFI,MAG MPI & HORIZON MIE | V8 | 1994-2001 | 0F115700 & up ⑥ | N/A | N/A | 18-5405 | 18-5354 | 18-5443 | 18-5281 | 18-5494-1 ④⊕ 18-5498-1 ④⊕ | N/A | 18-8832-1 |
| 454 MAG MPI HORIZON MIE | V8 | 1998 | 0L002200-0L086000 ⑥ | N/A | N/A | 18-5405 | 18-5354 | 18-5443 | 18-5281 | 18-5494-1 ④⊕ 18-5498-1 ④⊕ | N/A | N/A |
| 454 MAG MPI HORIZON MIE | V8 | 1999-2001 | 0L086001-0L674000 ⑥ | N/A | N/A | 18-5405 | 18-5354 | 18-5443 | 18-5281 | 18-5494-1 ④⊕ 18-5498-1 ④⊕ | N/A | 18-8832-1 |
| 390GM(482cid) | V8 | 1969-70 | 2781129-2825059 ⑥ | N/A | N/A | 18-5420 | 18-5389 | N/A | 18-5282 | N/A | N/A | 18-8803-2 |
| 460GM TRS | V8 | 1983-86 | 6180970-6181046 ① | 18-5314 | 18-5338 | 18-5404-1 | 18-5376 | 18-5433 | 18-5251 18-5271 ⑥ | 18-5494-1 ④ 18-5498-1 ④ 18-5313 ⑤ | 18-5296-2 | 18-8803-2 |
| 460GM TRS | V8 | 1983-86 | 6180970-6181046 ⑤ | 18-5317 | 18-5346 | 18-5420 | 18-5389 | 18-5433 | 18-5254 | 18-5494-1 ④⊕ 18-5498-1 ④⊕ 18-5313 ⑤ | N/A | 18-8803-2 |
| 465 | V8 | 1992-94 | 0D763732-0F213244 | N/A | N/A | 18-5431 | 18-5395 | 18-5438 | 18-5273 | N/A | N/A | 18-8837-1 |
| 496 / 8.1L | V8 | 2000 & Up | OM025000 & up → | N/A | N/A | N/A | N/A | N/A | N/A | N/A | N/A | 18-8838-1 |
| 500 | V8 | 1994-98 | 0F213293-OL001772 | N/A | N/A | 18-5431 | 18-5395 | 18-5438 | 18-5273 | N/A | N/A | 18-8837-1 |
| 500(Gen+) (502cid) | V8 | 1999 | OL414639-OL601036 ⑩ | N/A | N/A | 18-5431 | 18-5395 | 18-5438* | 18-5273 ⑥ | N/A | N/A | 18-8837-1 |
| 500GM EFI (502cid) | V8 | 1998-2000 | 0L001477 & up ⑥ | N/A | N/A | 18-5405 | 18-5354 | 18-5443 | 18-5281 | N/A | N/A | N/A |
| 502GM EFI & MAG MPI(502cid) | V8 | 1993-98 | 0D840650-0L085000 ⑥ | N/A | N/A | 18-5405 | 18-5354 | 18-5443 | 18-5281 | N/A | N/A | 18-8832-1 |
| 502GM MAG (502cid) | V8 | 1990-93 | 0C878221-0F114528 *★ | N/A | N/A | 18-5431 | 18-5395 | 18-5438* | 18-5273 ⑥ | N/A | N/A | 18-8804-1 |
| 502GM MAG (502cid) | V8 | 1998-2001 | 0L085001 & up ⑥ | N/A | N/A | 18-5405 | 18-5354 | 18-5443 | 18-5281 | N/A | N/A | 18-8832-1 |
| 8.2L GM MPI MIE (502cid) | V8 | 1996-2001 | 0F819620 & up ⑥ | N/A | N/A | 18-5405 | 18-5354 | 18-5443 | 18-5281 | N/A | N/A | 18-8832-1 |
| 8.2L GM MPI MIE (502cid) | V8 | 1990-96 | 0C878221-0F819619 *★⊕ | N/A | N/A | 18-5431 | 18-5395 | 18-5438* | 18-5273 ⑥ | N/A | N/A | 18-8804-1 |
| 525GM SC(502cid) | V8 | 1991-95 | 0D456000-0F877734 ⑩ | N/A | N/A | 18-5431 | 18-5395 | 18-5438* | 18-5273 ⑥ | N/A | N/A | 18-8804-1 |
| 525GM SC(502cid) | V8 | 1996-99 | OK000012 & up ⑩ | N/A | N/A | 18-5431 | 18-5395 | 18-5438* | 18-5273 ⑥ | N/A | N/A | 18-8837-1 |
| 575GM SC(502cid) | V8 | 2000-2005 | 0L306696 & up ⑥ | N/A | N/A | 18-5405 | 18-5354 | 18-5443 | 18-5281 | N/A | N/A | N/A |
| 600GM SC(502cid) | V8 | 1991-93 | 0D456489-0D763875 ⑩ | N/A | N/A | 18-5431 | 18-5395 | 18-5438* | 18-5273 ⑥ | N/A | N/A | 18-8837-1 |
| 600GM SC(502cid) | V8 | 1993-2001 | 0D763876 & up ⑩ | N/A | N/A | 18-5431 | 18-5395 | 18-5438* | 18-5273 ⑥ | N/A | N/A | 18-8837-1 |
| 500GM BULLDOG, 575GM(540cid) | V8 | 1990-2000 | 0C577003 -OM050281up ⑩ | N/A | N/A | 18-5431 | 18-5395 | 18-5438* | 18-5273 ⑥ | N/A | N/A | 18-8837-1 |
| 800GM SC (572cid) | V8 | 1993-2007 | 0D763836 & up ⑩ | N/A | N/A | 18-5431 | 18-5395 | 18-5438* | 18-5273 ⑥ | N/A | N/A | 18-8837-1 |

- NA Not applicable
- NLA No longer available
- ① Mallory Ignition
- ② Prestolite
- ③ Autolite Ignition
- ④ Mercury Ignition
- ⑤ Holley
- ⑥ Thunderbolt
- ⑦ For wire type lead use
- ⑧ With screw-down cap
- ⑨ With conventional ign.
- ⑩ Thunderbolt IV
- ⑪ With copper connector
- ⑫ Delco
- ⑬ Electronic dist. (std. Rotation)
- excl. Thunderbolt ign.
- ⑭ Mercury Ign.
- ⑮ Contact controlled dist. (std. Rotation) excl. Thunderbolt ign.
- ⑯ Delco EST system
- ⑰ Delco digital system
- ⑱ With dist. cap
- ⑲ Distributor mounted ignition amplifier
- ⑳ Mercury HEI
- Distributorless Ignition
- * These coils are the old standard series, not the current upgrade kit
- ⊕ Thunderbolt IV(1) System
- ⊕ Thunderbolt V Ignition
- ⊕ Thunderbolt IV(2) System
- ⊕ When replacing an HEI System with an Electronic

Distributor- the amplifier must be removed; the coil changed; and the plug wires may need to be changed out

PREMIUM MARINE SPARK PLUG WIRE LEADS

MAGFORCE™



OE Style boots provide a sealed barrier against heat, dirt and moisture.



Premium Marine Wire Leads
Magnetic Suppression Core
Manufactured for your specific application

- ★ Kevlar® core for maximum durability and long life.
- ★ Durable stainless steel wound conductor for maximum horsepower and engine performance.
- ★ Premium silicone jacketing and boots for the ultimate in high temperature protection.
- ★ Superior RFI suppression for the most sensitive electronic system.
- ★ Corrosion resistant stainless steel spark plug and distributor terminals for maximum conductivity.

| O.E. # | Cyl. | Part # | O.E. # | Cyl. | Part # |
|----------------------------|------|-----------|----------------------------|------|-----------|
| 84-816608Q81 | 8 | 18-8822-1 | 84-863656A2 | V6 | 18-8829-1 |
| 84-847701A7 | 8 | 18-8837-1 | 84-813720A12, 84-816761Q12 | 8 | 18-8802-1 |
| 84-813720A2, 84-816608Q61 | 8 | 18-8804-1 | 84-813720A13, 84-816761Q13 | 4 | 18-8811-1 |
| 84-813720A3, 84-816761Q3 | 8 | 18-8804-1 | 84-816761A4, 84-816761Q4 | 8 | 18-8804-1 |
| 84-813720A3, 84-816761Q3 | 8 | 18-8821-1 | 84-816761A4, 84-816761Q4 | 8 | 18-8821-1 |
| 84-813720A4, 84-816761Q4 | 8 | 18-8821-1 | 84-816761A8, 84-816761Q8 | L6 | 18-8809-1 |
| 84-813720A4, 84-816761Q4 | 8 | 18-8804-1 | 84-816761A9, 84-816761Q9 | 8 | 18-8803-2 |
| 84-813720A5, 84-816761Q5 | 4 | 18-8800-1 | 84-816761A17, 84-816761Q17 | 8 | 18-8821-1 |
| 84-813720A6, 84-816761Q6 | 4 | 18-8808-2 | 84-863656A1 | 8 | 18-8828-1 |
| 84-816761K14 | L4 | 18-8833-1 | 84-816608Q80 | 8 | 18-8830-1 |
| 84-813720A7, 84-816761Q7 | V6 | 18-8801-1 | 84-816608Q71 | 8 | 18-8836-1 |
| 84-813720A8, 84-816761Q8 | L6 | 18-8809-1 | 84-816608K68 | 8 | 18-8832-1 |
| 84-813720A9, 84-816761Q9 | 8 | 18-8803-2 | 84-816608Q83 | 8 | 18-8834-1 |
| 84-813720A10, 84-816761Q10 | 8 | 18-8803-2 | 84-881698 | 8 | 18-8838-1 |
| 84-813720A11, 84-816761Q16 | V6 | 18-8810-1 | 84-816608K68 | 8 | 18-8824-1 |
| 84-816608Q82 | V6 | 18-8835-1 | | | |

| Models | Cyl. | Ignition Type | Part # | Models | Cyl. | Ignition Type | Part # |
|----------------------------------|------|---------------|-----------|----------------------------------|------|-----------------|-----------|
| ALL | 4 | Digital | 18-8811-1 | 370 | 8 | Conventional | 18-8803-2 |
| 120 (153 CID) | 4 | Conventional | 18-8800-1 | 400 | 8 | Conventional | 18-8803-2 |
| 140 (181 CID) | 4 | Conventional | 18-8800-1 | 420 | 8 | Thunderbolt | 18-8804-1 |
| 150 | L6 | Conventional | 18-8809-1 | 420 | 8 | Thunderbolt | 18-8837-1 |
| 160 | L6 | Conventional | 18-8809-1 | 425 | 8 | Thunderbolt | 18-8837-1 |
| 165 | L6 | Conventional | 18-8809-1 | 440 | 8 | Conventional | 18-8803-2 |
| 185 CID | V6 | Conventional | 18-8801-1 | 454 CID | 8 | Thunderbolt | 18-8804-1 |
| 198 GM | 8 | Conventional | 18-8803-2 | 454 MAG | 8 | Thunderbolt | 18-8804-1 |
| 224 CID | 4 | Conventional | 18-8808-2 | 454 EFI, Mag MPI and Horizon MIE | 8 | Delco HEI | 18-8832-1 |
| 225 FORD | 8 | Conventional | 18-8803-2 | 454 Hi Perf | 8 | Thunderbolt | 18-8824-1 |
| 225 GM | 8 | Conventional | 18-8803-2 | 460 | 8 | Conventional | 18-8803-2 |
| 228 GM | 8 | Conventional | 18-8803-2 | 465 | 8 | Thunderbolt | 18-8837-1 |
| 229 CID | V6 | Conventional | 18-8801-1 | 496 | 8 | Distributorless | 18-8838-1 |
| 233 FORD | 8 | Conventional | 18-8803-2 | 500 | 8 | Thunderbolt | 18-8837-1 |
| 250 GM | 8 | Conventional | 18-8803-2 | 500 Bulldog | 8 | Thunderbolt | 18-8837-1 |
| 255 FORD | 8 | Conventional | 18-8803-2 | 502 Mag | 8 | Delco HEI | 18-8832-1 |
| 260 GM | 8 | Conventional | 18-8803-2 | 502 EFI & Mag MPI | 8 | Delco HEI | 18-8832-1 |
| 260 TR | 8 | Thunderbolt | 18-8804-1 | 525SC | 8 | Thunderbolt | 18-8837-1 |
| 262 CID | V6 | Thunderbolt | 18-8810-1 | 600SC | 8 | Thunderbolt | 18-8837-1 |
| 280 GM | 8 | Conventional | 18-8803-2 | 800SC | 8 | Thunderbolt | 18-8837-1 |
| 305 CID LH | 8 | Thunderbolt | 18-8804-1 | 888 FORD | 8 | Conventional | 18-8803-2 |
| 305 CID RH | 8 | Thunderbolt | 18-8804-1 | 898 GM | 8 | Conventional | 18-8803-2 |
| 320 EFI | 8 | Thunderbolt | 18-8804-1 | 2.5L | 4 | Conventional | 18-8800-1 |
| 330 | 8 | Conventional | 18-8803-2 | 3.0L | 4 | Conventional | 18-8800-1 |
| 330 TR | 8 | Thunderbolt | 18-8804-1 | 3.0LX | 4 | Delco EST | 18-8833-1 |
| 350 CID LH | 8 | Thunderbolt | 18-8804-1 | 3.7L | 4 | Conventional | 18-8808-2 |
| 350 CID RH | 8 | Thunderbolt | 18-8804-1 | 3.7XL | 4 | Conventional | 18-8808-2 |
| 350 MAG | 8 | Thunderbolt | 18-8804-1 | 4.3L | V6 | Thunderbolt | 18-8810-1 |
| 350 MAG SKI | 8 | Thunderbolt | 18-8821-1 | 4.3XL | V6 | Thunderbolt | 18-8810-1 |
| 350 MAG BRAVO MPI & GEN + | 8 | Delco HEI | 18-8836-1 | 4.3L EFI(TBI) | V6 | Thunderbolt | 18-8810-1 |
| 350 MAG MPI MIE (GEN +) | 8 | Delco HEI | 18-8832-1 | 4.3L MPI | V6 | Delco HEI | 18-8835-1 |
| 350 MAG MPI MIE (GEN +) | 8 | Mercury HEI | 18-8834-1 | 5.0L | 8 | Thunderbolt | 18-8804-1 |
| 350 MAG EFI SKI | 8 | Delco HEI | 18-8832-1 | 5.0L IB | 8 | Thunderbolt | 18-8804-1 |
| 350 MAG MPI SKI (GEN +) | 8 | Delco HEI | 18-8836-1 | 5.0LX | 8 | Thunderbolt | 18-8804-1 |
| BLACK SCORPION SKI (GEN+) 350CID | 8 | Delco HEI | 18-8832-1 | 5.0L Alpha & Bravo (Gen+) | 8 | Thunderbolt | 18-8821-1 |
| BLACK SCORPION SKI (GEN+) 350CID | 8 | Delco HEI | 18-8822-1 | 5.0L MIE MPI | 8 | Delco HEI | 18-8828-1 |
| MX 6.2 BLACK SCORPION SKI | 8 | Delco HEI | 18-8822-1 | 5.7L | 8 | Thunderbolt | 18-8804-1 |
| | | | | 5.7L IB | 8 | Thunderbolt | 18-8804-1 |
| | | | | 5.7L SKI | 8 | Conventional | 18-8802-1 |
| | | | | 7.4L | 8 | Thunderbolt | 18-8804-1 |
| | | | | 7.4L IB | 8 | Thunderbolt | 18-8804-1 |





**18-5225
SPARK PLUG WIRE KIT**

Replaces:
Mercury 84-99215A26,
84-813706A26
Kit includes 25 ft. roll of 7 MM hypalon ignition wire with a metallic core and a large assortment of three different end fittings.



BATTERY CABLES

| Part No. | Size | Color | Gauge | Part No. | Size | Color | Gauge |
|----------|------|-------|-------|----------|------|-------|-------|
| BC88523 | 2' | red | 4 | BC88563 | 6' | red | 2 |
| BC88533 | 2' | black | 4 | BC88573 | 6' | black | 2 |
| BC88543 | 4' | red | 2 | BC88583 | 8' | red | 1 |
| BC88553 | 4' | black | 2 | BC88593 | 8' | black | 1 |

Gauge cable with soldered lug terminals on each end to accept a 3/8" stud



**18-5226
IGNITION WIRE**
Metallic Core
100' Spool
7mm Hypalon

PKG. OF 10



**18-5224
18-5224-9^①
SPARK PLUG WIRE
TERMINAL**
Replaces: Mercury 20121

PKG. OF 10



**18-5750
18-5750-9^①
UNIVERSAL SPARK PLUG BOOTS**
Supplied complete w/Terminal Connector



**18-5752
UNIVERSAL
SPARK PLUG BOOT**
8mm

Standard Rotation

CCW Rotation

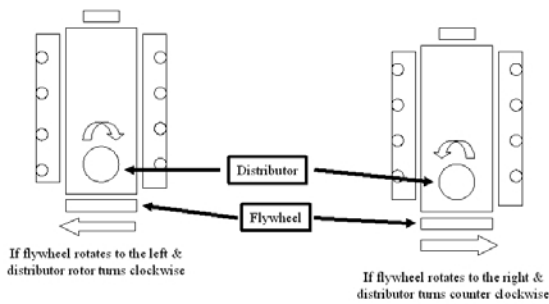

**18-5603
STARTER**

Replaces: 50-808011A4
Noseless:CCW Top mount rear entry starter for standard rotation GM & Ford engines. Can be used in place of 18-5908 and 18-5902



**18-6275
STARTER**

Replaces: 50-807904A1, 50-863007A1

- Permanent Magnet Gear Reduction Starter
- Inboard
- 2 Long Bolt Offset Pattern
- CW Rotation • SAE J1171
- Use w/ Late Model 3.0L Engines with 14" Flywheel

Fits : Volvo Penta, Mercruiser, Marine Power

^① Priced per Package



**18-5911
STARTER**

CE



**18-5900
REMANUFACTURED
STARTER**

(Heavy-Duty) (No Core) (Clockwise) For GM engines, bottom mount straight across bolt pattern. Standard rotation
Replaces: 50-76965A4,50-99417A2,50-99419A3, 50-17251A3, 50-77328A3
Replacement Solenoid: 18-5837
SAEJ1171



**18-5907
STARTER**

CE



**18-5901
REMANUFACTURED
STARTER**

(Heavy-Duty) (No Core) (Clockwise) Top mount rear entry starter for opposite rotation GM & Ford engines. Will also replace standard rotation. Will not replace non-starter mounted solenoids.
Mercruiser built 4 cyl. 165/170/180/190/470/485/488
Replaces: 50-72550A2,50-79604A3, 50-97499A2, R4
Replacement Solenoid: 18-5837
SAEJ1171

CE

**18-5913
STARTER
(Clockwise)**

**Delco permanent magnet gear reduction 2 bolt starter
12V - 11 Tooth - Offset Bolt Pattern
For: Late model GM - 14" Flywheel**
Replaces: 50-812428A3, 50-812604A2,
50-822330A2, 50-864340A2, 50-863007A1
Replacement Solenoid: 18-6287
SAEJ1171 FOR: 4.3L (1996 & UP); 5.0 & 5.7L (1998 & UP)



CE

**18-5919
STARTER**

Permanent magnet I/O starter
Replaces: 50-806963A4, 50-806965A2
Replacement Solenoid: 18-6287
Fits: Chevy Engines with 12 3/4" flywheels
Straight across bolt pattern
SN-OF803000AN/OF803114AN 4.3LX/LXH Alpha/Bravo 262 CID
SN-355305AN/22560AN 5.7L Alpha (EFI)/5.7L Bravo (EFI)
SAEJ1171





**18-5910
STARTER**

**18-5905
REMANUFACTURED STARTER**

(Heavy-Duty) (No Core) (Clockwise) Small block V-6 & V-8 GM engine with 14 1/4" flywheel and bottom mount, offset bolt pattern. For standard rotation engines.

Replaces: 50-12177A2, 50-99418A2



**18-5908
STARTER**

**18-5902
REMANUFACTURED STARTER**

(Heavy-Duty) (No Core) (Counter-Clockwise)
Top mount rear entry starter for standard rotation GM & Ford engines.

Replaces: 50-76965A3, 50-808011A1

Replacement Solenoid: 18-5837

SEAJ1171



**18-5903
REMANUFACTURED STARTER**
(No Core) (Clockwise) Bottom mount, two bolt pattern for standard rotation Ford engines.
Replaces: 50-69865A1, 50-12872, 50-56886
Replacement Solenoid: 18-5801



**18-2434
FLYWHEEL BELL HOUSING**

Replaces: 814309A1

For: GM V-8's Big & Small Blocks Inboard/Ski Models

STARTER BOLTS

| Description | Mercruiser # | Part # |
|--------------------------------------|--------------|------------------|
| Starter Bolt 3/8 - 16 - 4 21/32 Long | 10-805343-1 | 18-8401 |
| Starter Bolt 3/8 - 16 - 4 3/8 Long | 10-805343-2 | 18-8402 |
| Starter Bolt 3/8 - 16 - 1 13/16 Long | 10-805343-3 | 18-8403 |
| Starter Bolt 3/8 - 16 - 1 11/16 Long | 10-808343-4 | 18-8404-1 |



**18-5717
STARTER
BRUSH SET**
Replaces: 33270





**18-5804
SOLENOID**
Replaces: 13037
Delco



APPLICATION BEGINS ON PAGE 605





| | | |
|---|--|---|
|  <p>18-5837 SOLENOID Replaces: 89-99253, 89-18080 Delco</p> |  <p>18-5838 SOLENOID Replaces: 33261, 89902 Delco</p> |  <p>18-5840 SOLENOID Prestolite 15-79, SAW 4201, SAW4207, SAW4210</p> |
|---|--|---|

BRUSH SET/STARTER SWITCH APPLICATION

| Years | Volt. | Starter No. | Brush Set | Starter Switch | Years | Volt. | Starter No. | Brush Set | Starter Switch |
|---------|-------|-------------|-----------|----------------|---------|-------|-------------|-----------|----------------|
| 1977-82 | 12 | 1108755 | 18-5717 | 18-5838 | 1971-78 | 12 | ALL | 18-5717 | 18-5838 |
| 1977-82 | 12 | 1108756 | 18-5717 | — | 1969-78 | 12 | MEO-7003 | — | 18-5840 |
| 1977-82 | 12 | 1109484,5,6 | 18-5717 | 18-5838 | | | | | |

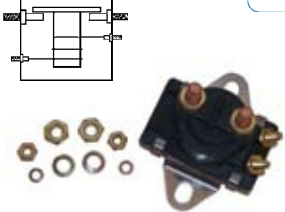
| | | |
|---|--|--|
| <p>① 18-5801D Display Package</p>  <p>18-5801 SOLENOID Replaces: 89-76416A1</p> | <p>① 18-5802D Display Package</p>  <p>18-5802 SOLENOID Replaces: 65057A1, 65057T1</p> | <p>① 18-5810D Display Package</p>  <p>18-5810 SOLENOID</p> |
|---|--|--|

| | | |
|---|---|--|
|  <p>18-5811 STARTER SOLENOID Replaces: 809463A1 For: PG 260 Series Starters, GM V6 & V8 (1983-Up)</p> | <p>① 18-5815D Display Package</p>  <p>18-5815 SOLENOID Replaces: 89-68258A4, 89-853654A1, 89-76545</p> | <p>① 18-5816D Display Package</p>  <p>18-5816 SOLENOID Replaces: 89-96054, T, 89-91975 (Flat Bracket)</p> |
|---|---|--|

| | | | |
|--|--|---|---|
| <p>① 18-5817D Display Package</p>  <p>18-5817 SOLENOID Replaces: 89-96158, T (Curved Bracket)</p> |  <p>18-5820 SOLENOID Replaces: 89-818999A2, 89-825842A1, 89-850188T1</p> | <p>① 18-5836D Display Package</p>  <p>18-5836 SOLENOID Replaces: 25661, 25661 1</p> |  <p>18-9802 TIMING LIGHT Self-powered accurate up to 10,000 RPM's</p> |
|--|--|---|---|

APPLICATION BEGINS ON PAGE 605

① Items ending in "D" are Display Packaged - Regular number is Non-Display

| | | | |
|---|--|--|--|
|  <p>18-6768 COMPLETE POWER TRIM PUMP ASSEMBLY Steel Bracket Replaces: 93247A7 Replacement pump for Prestolite high pressure/low flow system.</p> |  <p>18-6799 COMPLETE POWER TRIM PUMP ASSEMBLY Stainless Steel Bracket Mercury 93247A7 Replacement pump for Prestolite high pressure/low flow system. Salt water series. Stainless steel bracket.</p> |  <p>18-6763 TILT/TRIM MOTOR Replaces: 92975A6, 79271A4, 67914A2 To 1984. Fits most Mercury Sterndrives (Motor and Reservoir Only) For Repair Kit use: 18-6253</p> | |
|  <p>18-6769-1 TILT/TRIM PUMP Replaces: 14336A8, 88183A5 From 1984 Fits most Mercury Sterndrives</p> |  <p>18-6772 TILT PUMP MOTOR Replaces: 17649, 17649T, 891736T For late style Alpha I, Generation II, and Bravo drives; early style square motors. Mercury Sterndrive replacement for Oildyne units</p> |  <p>18-6274 TILT/TRIM MOTOR Replaces: 14336A20 Oildyne low pressure/high flow</p> | |
|  <p>18-6771 TILT/TRIM RESERVOIR Replaces: 18525A1</p> |  <p>18-6778 TILT/TRIM RESERVOIR Replaces: 883166A2 For: Tilt Motors with 4 Screw Attachments</p> |  <p>18-5872 STATOR Replaces: 398-6231A10 For: 3.7L 1983-89</p> | |
|  <p>18-6254 COMMUTATOR END PLATE Replaces: 392-2940 For : Use with Prestolite Pumps (Mercury #'s 79271A4 and 88475A5)</p> |  <p>18-6253 COMMUTATOR END PLATE For use with 18-6763</p> |  <p>18-6256 POWER TRIM SPRING SET Replaces: 392-2529 For : Use with Prestolite Pumps (Mercury #'s 74436A9, 79271A4, 88475A5 and 93247A4)</p> |  <p>18-6255 POWER TRIM BRUSH Replaces: 392-8989 For : Use with Prestolite Pumps (Mercury #'s 93247A4)</p> |

APPLICATION BEGINS ON PAGES 605

| | | |
|---|---|---|
|  <p>18-6293 ALTERNATOR Replaces: 862031T • SAE J1171 7SI/70 amp, Hinge Mount, Serpentine Pulley 2.44" Diameter</p> |  <p>18-6298 ALTERNATOR Replaces: 862031T • SAE J1171 7SI/70 amp, Hinge Mount, Serpentine Pulley 1.97" Diameter</p> |  <p>18-5983 ALTERNATOR Replaces: 862030T • SAE J1171 7SI/70 amp, Hinge Mount, Single Groove Pulley</p> |
|  <p>18-5956 ALTERNATOR (1-Wire) (No Core) (68 AMP) Single wire connection fits Mercruiser and many other applications. Equipped with fan and drive pulley. Replaces: 69729 • SAE J1171</p> |  <p>18-5950 ALTERNATOR (1-Wire) (No Core) (68 AMP) Single wire connection fits Mercruiser and many other applications. Equipped with fan and drive pulley. Replaces: 69729 • SAE J1171 (Remanufactured)</p> | |
|  <p>18-5957 ALTERNATOR (3-Wire) (No Core) (68 AMP) Replaces Mando, Motorola and original equipment Delco. Uses same electrical connections and mounting method. Equipped with fan and drive pulley. Replaces: 78477, 78403A2, 92497A3. • SAE J1171</p> |  <p>18-5951 ALTERNATOR (3-Wire) (No Core) (68 AMP) Replaces Mando, Motorola and original equipment Delco. Uses same electrical connections and mounting method. Equipped with fan and drive pulley. Replaces: 78477, 78403A2, 92497A3 (Remanufactured) • SAE J1171</p> | |
|  <p>18-5946 ALTERNATOR (1-Wire) (No Core) (68 AMP) Single wire connection fits Mercruiser and many other applications. Equipped with fan and serpentine drive pulley. • SAE J1171</p> |  <p>18-5945 ALTERNATOR (3-Wire) (No Core) (68 AMP) • SAE J1171 Replaces Mando, Motorola and original equipment Delco. Uses same electrical connections and mounting method. Equipped with fan and serpentine drive pulley.</p> | |

APPLICATION BEGINS ON PAGES 605

I/O



18-5960
ALTERNATOR
Serpentine Pulley • 65 Amp
Replaces: 807653T • SAE J1171



18-5966
ALTERNATOR
Single Groove Pulley • 55 Amp
Replaces: 817119A4, 12449A1 • SAE J1171



18-5967
ALTERNATOR
Serpentine Pulley • 55 Amp
Replaces: 807652T • SAE J1171



18-5965
ALTERNATOR
65 Amp
Replaces: 817119A1, 817119A4, 805884T
SAEJ1171



18-5953-1
ALTERNATOR CONVERSION KIT

Includes new 68 AMP alternator, mounting brackets
18-5968, pulley, wiring, hardware and instructions. Converts model 470 aluminum block Mercruiser engines serial number 4625580 & up with stator charging system and water cooled voltage regulator to alternator system. **NOTE: Fuse kit 18-8220 (sold separately) is required on engines with a Delco starter (round solenoid mounted to starter); Prestolite starters with remote solenoid DO NOT require fuse kit.**
Visually inspect starter prior to ordering conversion kit



18-5968
ALTERNATOR BRACKET
Replacement bracket for alternator conversion kit used on 470 Series Mercruiser included in 18-5953 kit



18-5978
ALTERNATOR BRACKET
Replaces: 47487T



18-8220
FUSE KIT
Replace: 88-79023A91

For use with 18-5953 alternator conversion kits installed on Mercruiser (Model 470) 3.7 liter aluminum block engines serial number 6902288 & Up.
90 AMP



18-5740
VOLTAGE REGULATOR
Replaces: 42785

APPLICATION BEGINS ON NEXT PAGE

| Model # | Cyl. | Years | Beg. S/N | End. S/N | Slave Solenoid | Reman Starter | New Starter | Reman Alternator | New Alternator |
|----------------|----------|-------------|----------|----------|----------------|---------------|-------------|------------------|----------------|
| 110 | GM 4 | 1963-1966 | 1538370 | 2044033 | 18-5836 | 18-5900 | 18-5911 | — | — |
| 120 | GM 4 | 1964-1975 | 1666601 | 4469865 | 18-5836 | 18-5900 | 18-5911 | 18-5951 | 18-5957 |
| 120 | GM 4 | 1976-1982 | 4469866 | 6229717 | 18-5815 | 18-5900 | 18-5911 | 18-5951 | 18-5957 |
| 120 / 2.5L | GM 4 | 1983-1989 | 6229718 | C853255 | 18-5817 | 18-5900 | 18-5911 | — | 18-5966 ④ |
| 140 | GM 4 | 1968-1975 | 2508261 | 4460664 | 18-5836 | 18-5900 | 18-5911 | 18-5951 | 18-5957 |
| 140 | GM 4 | 1976-1981 | 4460665 | 6229717 | 18-5815 | 18-5900 | 18-5911 | 18-5951 | 18-5957 |
| 140/3.0L | GM 4 | 1982-1989 | 6229718 | C856558 | 18-5817 | 18-5900 | 18-5911 | 18-5951 | 18-5957 |
| 140/3.0L/3.0LX | GM 4 | 1990-92 | C856559 | D831100 | 18-5817 | 18-5900 | 18-5911 | 18-5951 | 18-5957 |
| 140/3.0LX | GM 4 | 1992 and Up | D831101 | & Up | 18-5817 | N/A | 18-6275 | — | 18-5966 ④ |
| 165/3.7L | Merc 4 | 1987-1989 | B434941 | C762299 | 18-5802 | 18-5901 | 18-5907 | N/A | N/A |
| 170 | Merc 4 | 1985-1986 | 6916779 | B434940 | 18-5802 | 18-5901 | 18-5907 | N/A | N/A |
| 180/3.7LX | Merc 4 | 1987-1989 | B436391 | C762299 | 18-5802 | 18-5901 | 18-5907 | N/A | N/A |
| 190 | Merc 4 | 1985-1986 | 6916779 | B436390 | 18-5802 | 18-5901 | 18-5907 | N/A | N/A |
| 470 | Merc 4 | 1976-1984 | 4208730 | 6916778 | 18-5802 | — | — | N/A | N/A |
| 470MIE | Merc 4 | 1980-1981 | 5520115 | 6218036 | 18-5802 | — | — | N/A | N/A |
| 485 | Merc 4 | 1980-1984 | 5685394 | 6916778 | 18-5802 | — | — | N/A | N/A |
| 140 | GM 6 | 1963 | 1538930 | 1725960 | 18-5836 | 18-5900 | 18-5911 | — | — |
| 150 | GM 6 | 1964-66 | 1666495 | 2048046 | 18-5836 | 18-5900 | 18-5911 | — | — |
| 160 | GM 6 | 1967-69 | 2048022 | 2768031 | 18-5836 | 18-5900 | 18-5911 | — | — |
| 160 | GM 6 | 1969 | 2768032 | 2770031 | 18-5836 | 18-5900 | 18-5911 | 18-5951 | 18-5957 |
| 165 | GM 6 | 1970-1975 | 2770032 | 4471565 | 18-5836 | 18-5900 | 18-5911 | 18-5951 | 18-5957 |
| 165 | GM 6 | 1976-1981 | 4471566 | 5813433 | 18-5815 | 18-5900 | 18-5911 | 18-5951 | 18-5957 |
| 200 | GM 6 | 1969 | 2453769 | 2712072 | 18-5836 | 18-5900 | 18-5911 | — | — |
| 175/4.3L | GM V-6 | 1987-1992 | B527955 | D714106 | 18-5816 | — | 18-5913 | — | 18-5966 ④ |
| 185 | GM V-6 | 1983-1984 | 6330183 | 6919655 | 18-5816 | 18-5900 | 18-5911 | — | 18-5966 ④ |
| 185 | GM V-6 | 1985-1987 | A331455 | B527954 | 18-5816 | N/A | 18-5913 | — | 18-5966 ④ |
| 205 | GM V-6 | 1985-1991 | A331455 | D714369 | 18-5816 | N/A | 18-5913 | — | 18-5966 ④ |
| 262 Mag. EFI | GM V-6 | 1996-1997 | F803800 | K999999 | 18-5817 | N/A | 18-5913 | — | 18-5960 |
| 262 Mag. EFI | GM V-6 | 1996-1997 | F803800 | K999999 | 18-5817 | N/A | 18-5913 | — | 18-5960 |
| 4.3L/LX/LXH | GM V-6 | 1992-1997 | D714107 | K999999 | 18-5817 | — | 18-5913 | — | 18-5967 |
| 4.3L/LX/LXH | GM V-6 | 1996-1997 | F803000 | K999999 | 18-5817 | — | 18-5913 | — | 18-5967 |
| 4.3L/LH | GM V-6 | 1998-Up | L010044 | & Up | 18-5817 | — | 18-5913 | — | 18-5967 |
| 4.3EFI | GM V-6 | 1998-Up | L012009 | & Up | 18-5817 | — | 18-5913 | — | 18-5960 |
| 190 | GM V-8 | 1963-1964 | 1564539 | 1730903 | 18-5836 | 18-5900 | 18-5911 | — | — |
| 200 | GM V-8 | 1985-1986 | 6218462 | B525981 | 18-5816 | 18-5900 | 18-5911 ① ③ | — | 18-5966 ④ |
| 200 | GM V-8 | 1985-1986 | 6218462 | B525981 | 18-5816 | 18-5905 | 18-5910 ② ⑥ | — | 18-5966 ④ |
| 200/5.0L | GM V-8 | 1987-1995 | B525982 | F600999 | 18-5816 | 18-5905 | 18-5910 | — | 18-5966 ④ |
| 200/5.0L | GM V-8 | 1987-1995 | B525982 | F600999 | 18-5817 | 18-5905 | 18-5910 | — | 18-5966 ④ |
| 215 MCM & MIE | Ford V-8 | 1970-1972 | 2781153 | 3563181 | 18-5836 | 18-5902 | 18-5908 ① | 18-5951 | 18-5957 |
| 215 MCM & MIE | Ford V-8 | 1970-1972 | 2781153 | 3563181 | 18-5836 | 18-5901 | 18-5907 ⑤ | 18-5951 | 18-5957 |
| 225 | Ford V-8 | 1973-1974 | 3385721 | 4166999 | 18-5802 | 18-5903 | — | 18-5951 | 18-5957 |
| 225 MIE | Ford V-8 | 1973-1974 | 3385721 | 4176999 | 18-5836 | 18-5902 | 18-5908 ① | 18-5951 | 18-5957 |
| 225 MIE | Ford V-8 | 1973-1974 | 3385721 | 4176999 | 18-5836 | 18-5901 | 18-5907 ⑤ | 18-5951 | 18-5957 |
| 888 | Ford V-8 | 1971-1977 | 3108723 | 4612109 | 18-5802 | 18-5903 | — ② | 18-5951 | 18-5957 |
| 888 | Ford V-8 | 1971-1977 | 4612110 | & Up | 18-5801 | 18-5903 | — | 18-5951 | 18-5957 |
| 225 | GM V-8 | 1963-1966 | 1539620 | 2278646 | 18-5836 | 18-5900 | 18-5911 | — | — |
| 225 MIE | GM V-8 | 1968 | 2278647 | 2694014 | 18-5836 | 18-5902 | 18-5908 ① | — | — |
| 225 MIE | GM V-8 | 1968 | 2278647 | 2694014 | 18-5836 | 18-5901 | 18-5907 ⑤ | — | — |
| 225 | GM V-8 | 1967-1969 | 2278647 | 2694014 | 18-5836 | — | — | — | — |
| 228/230 | GM V-8 | 1977-1986 | 4765100 | B525981 | 18-5816 | 18-5900 | 18-5911 ① ③ | — | 18-5966 ④ |
| 228/230 | GM V-8 | 1977-1986 | 4765100 | B525981 | 18-5816 | 18-5905 | 18-5910 ② ⑥ | — | 18-5966 ④ |
| 228 MIE | GM V-8 | 1977-1980 | 4765100 | 5907057 | 18-5815 | 18-5902 | 18-5908 ① | 18-5951 | 18-5957 |
| 228 MIE | GM V-8 | 1977-1980 | 4765100 | 5907057 | 18-5815 | 18-5901 | 18-5907 ⑤ | 18-5951 | 18-5957 |
| 230/5.0LX | GM V-8 | 1987-1995 | B525982 | F600999 | 18-5816 ⑩ | 18-5905 | 18-5910 ③ | — | 18-5966 ④ |
| 230/5.0LX | GM V-8 | 1987-1995 | B525982 | F600999 | 18-5817 ⑨ | 18-5905 | 18-5910 ③ | — | 18-5966 ④ |
| 230/5.0L MIE | GM V-8 | 1987-1988 | 5907058 | B788151 | 18-5816 | 18-5902 | 18-5908 ① | — | 18-5966 ④ |
| 230/5.0L MIE | GM V-8 | 1987-1988 | 5907058 | B788151 | 18-5816 | 18-5901 | 18-5907 ⑤ | — | 18-5966 ④ |
| 5.0L | GM V-8 | 1998 & Up | L015751 | & Up | 18-5817 | — | 18-5913 | — | 18-5967 |
| 5.0L EFI | GM V-8 | 1998 & Up | L015751 | & Up | 18-5817 | — | 18-5913 | — | 18-5960 |
| 198 MIE | GM V-8 | 1977 | 4762210 | 6218461 | 18-5815 | 18-5902 | 18-5908 ① | 18-5951 | 18-5957 |
| 198 MIE | GM V-8 | 1977 | 4762210 | 6218461 | 18-5815 | 18-5901 | 18-5907 ⑤ | 18-5951 | 18-5957 |
| 898 | GM V-8 | 1977-1982 | 4762210 | 6218461 | 18-5801 | 18-5900 | 18-5911 | 18-5951 | 18-5957 |

① For 12 3/4" Dia. Flywheel

② For 14" Dia. Flywheel

③ For permanent magnet models use 18-5919

④ 55 AMP up grade to 65 AMP use 18-5965

⑤ Black

⑥ For permanent magnet models use 18-5913

⑦ Bravo drive

⑧ Firepower ignition

⑨ Ignition module mounted on distributor

⑩ Ignition module mounted on elbow

① LH rotation

② NLA for models prior to S/N 4167000

③ PG 260 (9-1/4" long)

④ PG260F1 (8-1/2" long)

⑤ RH Rotation

⑥ Standard ignition

⑦ Thunderbolt ignition

⑧ Thunderbolt IV

⑨ Thunderbolt V

⑩ Transmission models



MERCUISER

Electrical System



| Model # | Cyl. | Years | Beg. S/N | End. S/N | Slave Solenoid | Reman. Starter | New Starter | Reman. Alternator | New Alternator |
|--------------------|----------|-----------|----------|----------|----------------|----------------|-------------|-------------------|----------------|
| 898 | GM V-8 | 1983-1984 | 621462 | B525981 | 18-5816 | 18-5900 | 18-5911 ① ③ | — | 18-5966 ④ |
| 898 | GM V-8 | 1983-1984 | 621462 | B525981 | 18-5816 | 18-5905 | 18-5910 ② ⑥ | — | 18-5966 ④ |
| 233 | Ford V-8 | 1975-1977 | 4173000 | 4902304 | 18-5801 | 18-5903 | — | 18-5951 | 18-5957 |
| 233 MIE | Ford V-8 | 1975-1976 | 4173000 | 4775784 | 18-5836 | 18-5902 | 18-5908 ① | 18-5951 | 18-5957 |
| 233 MIE | Ford V-8 | 1975-1976 | 4173000 | 4775784 | 18-5836 | 18-5901 | 18-5907 ⑤ | 18-5951 | 18-5957 |
| 250 MCM & MIE | GM V-8 | 1968-1969 | 2314301 | 2639854 | 18-5836 | 18-5902 | 18-5908 ① | — | — |
| 250 MCM & MIE | GM V-8 | 1968-1969 | 2314301 | 2639854 | 18-5836 | 18-5901 | 18-5907 ⑤ | — | — |
| 250 | GM V-8 | 1977 | 4768000 | 4908849 | 18-5801 | 18-5900 | 18-5911 | 18-5951 | 18-5957 |
| 255 | Ford V-8 | 1973-1974 | 3258728 | 4175499 | 18-5802 | 18-5903 | — | 18-5951 | 18-5957 |
| 255 MIE | Ford V-8 | 1973-1974 | 3258728 | 4178299 | 18-5836 | 18-5902 | 18-5908 ① | 18-5951 | 18-5957 |
| 255 MIE | Ford V-8 | 1973-1974 | 3258728 | 4178299 | 18-5836 | 18-5901 | 18-5907 ⑤ | 18-5951 | 18-5957 |
| 255 | GM V-8 | 1975-1976 | 4175500 | 4767999 | 18-5815 | 18-5900 | 18-5911 | 18-5951 | 18-5957 |
| 255 MIE | GM V-8 | 1975-1980 | 4175500 | 5907057 | 18-5815 | 18-5902 | 18-5908 ① | 18-5951 | 18-5957 |
| 255 MIE | GM V-8 | 1975-1980 | 4175500 | 5907057 | 18-5815 | 18-5901 | 18-5907 ⑤ | 18-5951 | 18-5957 |
| 260 | GM V-8 | 1978-1982 | 4908850 | 6218461 | 18-5801 | 18-5900 | 18-5911 | 18-5951 | 18-5957 |
| 260 | GM V-8 | 1982-1986 | 6218462 | B525981 | 18-5816 | 18-5900 | 18-5911 ① ③ | — | 18-5966 ④ |
| 260 | GM V-8 | 1982-1986 | 6218462 | B525981 | 18-5816 | 18-5905 | 18-5910 ② ⑥ | — | 18-5966 ④ |
| 260/5.7L | GM V-8 | 1987-1995 | B525982 | F600999 | 18-5816 ⑩ | 18-5905 | 18-5910 ⑥ | — | 18-5966 ④ |
| 260/5.7L | GM V-8 | 1987-1995 | B525982 | F600999 | 18-5817 ⑨ | 18-5905 | 18-5910 ⑥ | — | 18-5966 ④ |
| 260/5.7L MIE | GM V-8 | 1987-1995 | 5907058 | F746099 | 18-5816 | 18-5902 | 18-5908 ① | — | 18-5966 ④ |
| 260/5.7L MIE | GM V-8 | 1987-1995 | 5907058 | F746099 | 18-5816 | 18-5901 | 18-5907 ⑤ | — | 18-5966 ④ |
| 5.7L/LX | GM V-8 | 1996 | F601000 | K001526 | 18-5817 | — | 18-5913 | — | 18-5966 ④ |
| 5.7L/LX | GM V-8 | 1997 & Up | K001527 | & Up | 18-5817 | — | 18-5913 | — | 18-5967 |
| 5.7L/LX EFI | GM V-8 | 1995-1996 | F225560 | K001505 | 18-5816 | — | 18-5913 | — | 18-5965 |
| 5.7L/LX EFI | GM V-8 | 1997 | K001506 | K999999 | 18-5816 | — | 18-5913 | — | 18-5960 |
| 5.7L EFI | GM V-8 | 1998 & Up | L010035 | & Up | 18-5816 | — | 18-5913 | — | 18-5960 |
| 5.7L MIE | GM V-8 | 1994-1996 | F622151 | K040306 | 18-5816 | 18-5902 | 18-5908 ① | — | 18-5966 ④ |
| 5.7L MIE | GM V-8 | 1994-1996 | F622151 | K040306 | 18-5816 | 18-5901 | 18-5907 ⑤ | — | 18-5966 ④ |
| 5.7L MIE | GM V-8 | 1977 & Up | K040307 | & Up | 18-5817 | 18-5902 | 18-5908 | — | 18-5967 |
| 5.7L EFI MIE | GM V-8 | 1997 | K040300 | K999999 | 18-5816 | 18-5902 | 18-5908 | — | 18-5960 |
| 5.7L Ski | GM V-8 | 1985-1995 | A338533 | F775199 | 18-5816 | — | 18-5913 ⑤ | — | 18-5966 ④ |
| 5.7L Ski | GM V-8 | 1985-1995 | A338533 | F775199 | 18-5816 | 18-5901 | 18-5907 ① | — | 18-5966 ④ |
| 5.7L Ski | GM V-8 | 1996 | F775200 | K040003 | 18-5817 | — | 18-5913 | — | 18-5966 ④ |
| 5.7L Ski | GM V-8 | 1997 | K040004 | K999999 | 18-5817 | — | 18-5913 | — | 18-5967 |
| 5.7L Ski | GM V-8 | 1998 & Up | L002005 | & Up | 18-5817 | — | 18-5913 | — | 18-5967 |
| 350 Mag. Alpha | GM V-8 | 1986-1995 | A635178 | F600999 | 18-5816 ⑩ | 18-5905 | 18-5910 ⑥ | — | 18-5966 ④ |
| 350 Mag. Alpha | GM V-8 | 1987-1996 | B525982 | K001526 | 18-5817 ⑨ | 18-5905 | 18-5910 ⑥ | — | 18-5966 ④ |
| 350 Mag. Alpha | GM V-8 | 1997 | K001527 | K999999 | 18-5817 | — | 18-5913 | — | 18-5967 |
| 350 Mag. EFI & MPI | GM V-8 | 1995-1996 | F415189 | K001500 | 18-5816 | — | 18-5913 | — | 18-5965 |
| 350 Mag. EFI & MPI | GM V-8 | 1997 & Up | K001501 | & Up | 18-5816 | — | 18-5913 | — | 18-5960 |
| 350 Mag. MPI MIE | GM V-8 | 1998 & Up | L002008 | & Up | 18-5816 | 18-5908 | 18-5902 | — | 18-5960 |
| 350 Mag Ski | GM V-8 | 1991-1996 | D505450 | K040399 | 18-5816 ⑧ | — | 18-5913 | — | 18-5966 ④ |
| 350 Mag Ski | GM V-8 | 1991-1996 | D505450 | K040399 | 18-5817 ⑨ | — | 18-5913 | — | 18-5966 ④ |
| 350 Mag Ski | GM V-8 | 1997 | K040400 | K999999 | 18-5817 | — | 18-5913 | — | 18-5967 |
| 350 Mag EFI Ski | GM V-8 | 1994-1997 | F215561 | K999999 | 18-5816 | — | 18-5913 | — | 18-5965 |
| 350 Mag MPI Ski | GM V-8 | 1995-1996 | F350583 | F799999 | 18-5816 | — | 18-5913 | — | 18-5965 |
| 350 Mag MPI Ski | GM V-8 | 1998 & Up | L002600 | & Up | 18-5817 | — | 18-5913 | — | 18-5960 |
| Black Scorpion | GM V-8 | 1996 | F800000 | K040000 | 18-5816 | — | 18-5913 | — | 18-5965 |
| Black Scorpion | GM V-8 | 1997 & Up | K040001 | & Up | 18-5816 | — | 18-5913 ⑤ | — | 18-5960 |
| Black Scorpion | GM V-8 | 1997 & Up | K040001 | & Up | 18-5816 | — | 18-5913 ④ | — | 18-5960 |
| 270 MCM & MIE | GM V-8 | 1969-1972 | 2851074 | 3385720 | 18-5836 | 18-5902 | 18-5908 ① | 18-5951 | 18-5957 |
| 270 MCM & MIE | GM V-8 | 1969-1972 | 2851074 | 3385720 | 18-5836 | 18-5901 | 18-5907 ⑤ | 18-5951 | 18-5957 |
| 280 TRS | GM V-8 | 1975-1976 | 4176250 | 4770199 | 18-5815 | 18-5900 | 18-5911 | 18-5951 | 18-5957 |
| 300 TR TEMPEST | GM V-8 | 1985-1986 | 6668677 | B430367 | 18-5816 | 18-5908 | 18-5902 | — | 18-5966 ④ |
| 300 MR TEMPEST | GM V-8 | 1985-1986 | 6668677 | B430367 | 18-5816 | — | 18-5919 ① | — | 18-5966 ④ |
| 300 MR TEMPEST | GM V-8 | 1985-1986 | 6668677 | B430367 | 18-5816 | — | 18-5913 ② | — | 18-5966 ④ |
| 320 EFI | GM V-8 | 1987-1989 | A543604 | C622418 | 18-5816 | — | 18-5913 | — | 18-5966 ④ |
| 325 MCM & MIE | GM V-8 | 1968-1970 | 2278747 | 2761141 | 18-5836 | 18-5902 | 18-5908 ① | — | — |
| 325 MCM & MIE | GM V-8 | 1968-1970 | 2278747 | 2761141 | 18-5836 | 18-5901 | 18-5907 ⑤ | — | — |
| 325 MCM & MIE | GM V-8 | 1970-1974 | 2761142 | 3780449 | 18-5836 | 18-5902 | 18-5908 ① | 18-5951 | 18-5957 |
| 325 MCM & MIE | GM V-8 | 1970-1974 | 2761142 | 3780449 | 18-5836 | 18-5901 | 18-5907 ⑤ | 18-5951 | 18-5957 |

① For 12 3/4" Dia. Flywheel

② For 14" Dia. Flywheel

③ For permanent magnet models use 18-5919

④ 55 AMP up grade to 65 AMP use 18-5965

⑤ Black

⑥ For permanent magnet models use 18-5913

⑦ Bravo drive

⑧ Firepower ignition

⑨ Ignition module mounted on distributor

⑩ Ignition module mounted on elbow

① LH rotation

② NLA for models prior to S/N 4167000

③ PG 260 (9-1/4" long)

④ PG260F1 (8-1/2" long)

⑤ RH Rotation

⑥ Standard ignition

⑦ Thunderbolt ignition

⑧ Thunderbolt IV

⑨ Thunderbolt V

⑩ Transmission models

| Model # | Cyl. | Years | Beg. S/N | End. S/N | Slave Solenoid | Reman. Starter | New Starter | Reman. Alternator | New Alternator |
|--------------------|--------|-----------|----------|----------|----------------|----------------|-------------|-------------------|----------------|
| 330 | GM V-8 | 1977-1981 | 4623115 | 6083144 | 18-5836 ⑦ | — | 18-5913 | 18-5951 | 18-5957 |
| 330 | GM V-8 | 1977-1981 | 4623115 | 6083144 | 18-5815 ⑥ | — | 18-5913 | 18-5951 | 18-5957 |
| 330 | GM V-8 | 1982-1987 | 6083145 | B816540 | 18-5816 | 18-5902 | 18-5908 | — | 18-5966 ④ |
| 330 MIE | GM V-8 | 1977-1980 | 4623115 | 5889913 | 18-5836 ⑦ | 18-5902 | 18-5908 ① | 18-5951 | 18-5957 |
| 330 MIE | GM V-8 | 1977-1980 | 4623115 | 5889913 | 18-5815 ⑥ | 18-5901 | 18-5907 ⑤ | 18-5951 | 18-5957 |
| 340/7.4L MIE w/BW | GM V-8 | 1981-1992 | 5889914 | D715493 | 18-5816 | 18-5902 | 18-5908 ① | — | 18-5966 ④ |
| 340/7.4L MIE w/BW | GM V-8 | 1981-1992 | 5889914 | D715493 | 18-5816 | 18-5901 | 18-5907 ⑤ | — | 18-5966 ④ |
| 7.4L | GM V-8 | 1988-1991 | B771113 | D603117 | 18-5816 | 18-5905 | 18-5910 ⑥ | — | 18-5966 ④ |
| 7.4L | GM V-8 | 1988-1996 | B771113 | F800699 | 18-5816 ⑩ | 18-5905 | 18-5910 ⑥ | — | 18-5966 ④ |
| 7.4L | GM V-8 | 1992-1997 | D603118 | K999999 | 18-5817 ⑨ | — | 18-5913 | — | 18-5966 ④ |
| 7.4LX EFI & MPI | GM V-8 | 1996-1997 | F602010 | K999999 | 18-5816 | — | 18-5913 | — | 18-5965 |
| 7.4L MPI | GM V-8 | 1998 & Up | L010003 | & Up | 18-5817 | — | 18-5913 | — | 18-5960 |
| 7.4L MIE | GM V-8 | 1989-1996 | C391564 | F820141 | 18-5816 ⑧ | 18-5902 | 18-5908 | — | 18-5966 ④ |
| 7.4L MIE | GM V-8 | 1992-1997 | D715494 | K999999 | 18-5817 ⑨ | 18-5902 | 18-5908 | — | 18-5966 ④ |
| 7.4L EFI & MPI MIE | GM V-8 | 1995-1997 | F563052 | K999999 | 18-5816 | 18-5902 | 18-5908 | — | 18-5965 |
| 7.4L MPI MIE | GM V-8 | 1998 & Up | L002006 | & Up | 18-5817 | 18-5902 | 18-5908 | — | 18-5960 |
| 350 MIE | GM V-8 | 1974-1976 | 3780450 | 4623109 | 18-5836 | 18-5902 | 18-5908 ① | 18-5951 | 18-5957 |
| 350 MIE | GM V-8 | 1974-1976 | 3780450 | 4623109 | 18-5836 | 18-5901 | 18-5907 ⑤ | 18-5951 | 18-5957 |
| 370 TRS | GM V-8 | 1978-1985 | 4179554 | 6721527 | 18-5815 | 18-5902 | 18-5908 | 18-5951 | 18-5957 |
| 370 TRS | GM V-8 | 1978-1985 | 4179554 | 6721527 | 18-5815 | 18-5902 | 18-5908 | — | 18-5966 ④ |
| 370 TRS | GM V-8 | 1985-1987 | 6721528 | B714586 | 18-5816 | 18-5902 | 18-5908 | — | 18-5966 ④ |
| 390 MCM & MIE | GM V-8 | 1969-1970 | 2781129 | 3042731 | 18-5836 | 18-5902 | 18-5908 ① | 18-5951 | 18-5957 |
| 390 MCM & MIE | GM V-8 | 1969-1970 | 2781129 | 3042731 | 18-5836 | 18-5901 | 18-5907 ⑤ | 18-5951 | 18-5957 |
| 400 TRS | GM V-8 | 1980-1986 | 4179554 | B457644 | 18-5815 | 18-5902 | 18-5908 | 18-5951 | 18-5957 |
| 400 TRS | GM V-8 | 1980-1986 | 4179554 | B457644 | 18-5815 | 18-5902 | 18-5908 | — | 18-5966 ④ |
| 420 | GM V-8 | 1987-1989 | A398941 | B622418 | 18-5816 | 18-5902 | 18-5908 | — | 18-5966 ④ |
| 425 | GM V-8 | 1990-1992 | A398941 | D937011 | 18-5816 | 18-5902 | 18-5908 | — | 18-5966 ④ |
| 440 TRS | GM V-8 | 1983-1986 | 4179554 | B485220 | 18-5815 | 18-5902 | 18-5908 | 18-5951 | 18-5957 |
| 440 TRS | GM V-8 | 1983-1986 | 4179554 | B485220 | 18-5815 | 18-5902 | 18-5908 | — | 18-5966 ④ |
| 450 | GM V-8 | 1995-1996 | F347100 | F347277 | 18-5820 | — | 18-5913 | — | — |
| 454 Mag. | GM V-8 | 1986-1994 | A631894 | F304999 | 18-5816 | — | 18-5913 | — | 18-5966 ④ |
| 454 Mag. | GM V-8 | 1995-1997 | F305000 | K999999 | 18-5817 | — | 18-5913 | — | 18-5966 ④ |
| 454 Mag. MPI | GM V-8 | 1994-1997 | F115700 | K999999 | 18-5816 | — | 18-5913 | — | 18-5965 |
| 454 Mag. MPI | GM V-8 | 1998 & Up | L010029 | & Up | 18-5816 | — | 18-5913 | — | 18-5960 |
| 454 Mag. MPI MIE | GM V-8 | 1996-1997 | F820100 | K999999 | 18-5816 | — | 18-5913 | — | 18-5965 |
| 454 Mag. MPI MIE | GM V-8 | 1998 & Up | L002200 | & Up | 18-5816 | 18-5902 | 18-5908 | — | 18-5960 |
| 454 EFI Ski | GM V-8 | 1995-1996 | F215800 | F820099 | 18-5816 | — | 18-5913 | — | 18-5965 |
| 460 TRS | GM V-8 | 1983-1986 | 4179554 | 6181046 | 18-5815 | 18-5902 | 18-5908 | 18-5951 | 18-5957 |
| 460 TRS | GM V-8 | 1983-1986 | 4179554 | 6181046 | 18-5815 | 18-5902 | 18-5908 | — | 18-5966 ④ |
| 465 | GM V-8 | 1990-1994 | C849992 | F213244 | 18-5816 ⑥ | — | 18-5913 ⑦ | — | 18-5966 ④ ⑤ |
| 465 | GM V-8 | 1990-1994 | C849992 | F213244 | — | 18-5902 | 18-5908 ⑩ | — | — |
| 500 | GM V-8 | 1994-1997 | F213293 | & Up | 18-5820 | — | 18-5913 ⑦ | — | — |
| 500 | GM V-8 | 1994-1995 | F213293 | & Up | 18-5820 | 18-5902 | 18-5908 ⑩ | — | — |
| 500 Bulldog | GM V-8 | 1990-1996 | C577254 | & Up | 18-5820 ⑧ | — | 18-5913 ⑦ | — | — |
| 500 Bulldog | GM V-8 | 1990-1996 | C577254 | & Up | 18-5816 ⑧ | 18-5902 | 18-5908 ⑩ | — | 18-5966 ④ ⑤ |
| 502 Mag. Bravo | GM V-8 | 1990-1993 | C878221 | F114528 | 18-5816 | — | 18-5913 | — | 18-5966 ④ |
| 502 Mag. MPI | GM V-8 | 1993-1997 | D840650 | K999999 | 18-5816 | — | 18-5913 | — | 18-5965 |
| 502 Mag. MPI | GM V-8 | 1998 & Up | L017000 | & Up | 18-5816 | — | 18-5913 | — | 18-5960 |
| 525 SC | GM V-8 | 1991-1993 | D456000 | D763831 | 18-5816 | — | 18-5913 ⑦ | — | 18-5966 ④ ⑤ |
| 525 SC | GM V-8 | 1991-1993 | D456000 | D763831 | 18-5816 | 18-5902 | 18-5908 ⑩ | — | — |
| 525 SC | GM V-8 | 1993-1997 | D763871 | & Up | 18-5820 | — | 18-5913 ⑦ | — | 18-5966 ④ ⑤ |
| 525 SC | GM V-8 | 1993-1997 | D763871 | & Up | 18-5820 | 18-5902 | 18-5908 ⑩ | — | — |
| 575 | GM V-8 | 1986-1992 | A677429 | D763716 | 18-5816 | 18-5902 | 18-5908 | — | 18-5966 ④ |
| 600 SC | GM V-8 | 1991-1996 | D456489 | F877642 | 18-5816 ⑧ | 18-5902 | 18-5908 | — | 18-5966 ④ ⑤ |
| 600 SC | GM V-8 | 1991-1996 | D456489 | F877642 | 18-5820 ⑧ | 18-5902 | 18-5908 | — | — |
| 600 SC | GM V-8 | 1997 | K000227 | & Up | 18-5820 | — | 18-5913 ⑩ | — | — |
| 800 SC | GM V-8 | 1993-1996 | D763836 | & Up | 18-5820 | 18-5902 | 18-5908 ⑩ | — | — |
| 8.2L MIE | GM V-8 | 1990-1996 | C878221 | F819619 | 18-5816 ⑧ | 18-5902 | 18-5908 | — | 18-5966 ④ |
| 8.2L MIE | GM V-8 | 1993-1996 | D857200 | F819619 | 18-5817 | 18-5902 | 18-5908 | — | 18-5966 ④ |
| 8.2L MPI MIE | GM V-8 | 1996-1997 | F819620 | K999999 | 18-5816 | 18-5902 | 18-5908 | — | 18-5965 |
| 8.2L MPI MIE | GM V-8 | 1998 & Up | L002450 | & Up | 18-5816 | 18-5902 | 18-5908 | — | 18-5960 |

① For 12 3/4" Dia. Flywheel

② For 14" Dia. Flywheel

③ For permanent magnet models use 18-5919

④ 55 AMP up grade to 65 AMP use 18-5965

⑤ Black

⑥ For permanent magnet models use 18-5913

⑦ Bravo drive

⑧ Firepower ignition

⑨ Ignition module mounted on distributor

⑩ Ignition module mounted on elbow

⑪ LH rotation

⑫ NLA for models prior to S/N 4167000

⑬ PG 260 (9-1/4" long)

⑭ PG260F1 (8-1/2" long)

⑮ RH Rotation

⑯ Standard ignition

⑰ Thunderbolt ignition

⑱ Thunderbolt IV

⑲ Thunderbolt V

⑳ Transmission models

NEW



18-7662
FUEL PRESSURE REGULATOR
Replaces: 885174
4.3L, 5.0L, 5.7L & 6.2L MPI engines with
555 ECM-regulator mounted on fuel rail

NEW



18-7663
FUEL PRESSURE REGULATOR
Replaces: 802630T01
7.4L MPI (L29)



18-7651
FUEL PRESSURE REGULATOR
Replaces: 12026



18-7652
FUEL PRESSURE REGULATOR
Replaces: 805227A1



18-7600
TEMPERATURE SENSOR
Replaces: 805218T



18-7630
THROTTLE POSITION SENSOR
Replaces: 805226A1



18-7632
IDLE AIR CONTROL MOTOR
Replaces: 805224A1

NEW



18-7660
MAP SENSOR
Replaces: 881731
V-6 & V-8 MPI engines with 555 ECM

NEW



18-7668
MAP SENSOR
Replaces: 854445
525 EFI



18-7680
MAP SENSOR
Replaces: 805217A1

FUEL INJECTION SYSTEM APPLICATION

| Model | Beg. Serial # | End. Serial # | MAP Sensor | Throttle Position Sensor | Pressure Regulator | Idle Air Control | Coolant Temperature Sensor | Throttle Body Gasket |
|------------------------------|---------------|---------------|------------|--------------------------|--------------------|------------------|----------------------------|----------------------|
| 5.7 (350) MAGNUM BRAVO (EFI) | F602000 | & UP | 18-7680 | 18-7630 | — | 18-7632 | 18-7600 | 18-0740 |
| 5.7 BRAVO 350 MAGNUM (TBI) | F752400 | & UP | 18-7680 | 18-7630 | — | 18-7632 | 18-7600 | — |
| 320 (EFI) | A543604 | & UP | — | — | 18-7651 | — | — | — |
| 7.4 (454) | F563052 | & UP | 18-7680 | 18-7630 | — | 18-7632 | 18-7600 | 18-0740 |

NEW



18-7627
INTAKE MANIFOLD

Small-block GM with vortec cylinder heads

NEW



18-7628
INTAKE MANIFOLD

Small-block GM with vortec cylinder heads with brass lined water jackets

ALL SIERRA CARBURETORS INCLUDE BASE GASKET

- Precision remanufactured to meet or exceed OEM specifications
- Re-calibrated and re-engineered to maximize fuel efficiency and performance
- All carburetors are flow tested throughout the entire throttle range
- Fuel mixture and idle settings are pre-set to ensure that only minor idle and choke adjustments are necessary during installation
- All bases are resurfaced and throttle shaft bushings replaced

NEW



18-7639
CARBURETOR

Replaces: 3310-864943A01
Mercarb-5.7L 2V 1998 and newer 5.7L
(OL010337-OW300754) & 5.7L MIE
(OL002003-OW090899)
(Remanufactured)

NEW



18-7640
CARBURETOR

Universal Q-jet with electric choke
(Remanufactured)

18-7603-1
CARBURETOR

2 Barrel - Rochester
Replaces: 1347-818622,
1376-5659A1, 1347-818622 1,
1347-818622R02
(Remanufactured)



18-7604-1
CARBURETOR

4 Barrel - Rochester
Replaces: 3304-9354A2,
1347-804623R02
(Remanufactured)



18-7605-1
CARBURETOR

4 Barrel - Rochester
Replaces: 1347-9661A3,
1347-804623A1,
1347-804623R02
(Remanufactured)



18-7608-1
CARBURETOR

2 Barrel - Rochester
Replaces: 1347-818620,
1347-818620 1, 1347-818620R02
(Remanufactured)



ALL SIERRA CARBURETORS INCLUDE BASE GASKET



18-7609-1
CARBURETOR
2 Barrel - Rochester
Replaces: 1347-818619,
1347-818619 1, 1347-818619 1R
(Remanufactured)



18-7610-1
CARBURETOR
2 Barrel - Rochester
Replaces: 1347-818621, 1347-818621 1, 1347-818621 1R02
(Remanufactured)



18-7611-2
CARBURETOR
2 Barrel - Rochester
Replaces: 3310-807312A1, 3310-807312R02
(Remanufactured)



18-7613-1
CARBURETOR
4 Barrel - Carter (Weber)
Replaces: 3310-806969A1, 3310-806969R01
(Remanufactured)



18-7615-1
CARBURETOR
4 Barrel - Rochester
Replaces: 1347-816373A4, 1347-804624R1, 1347-804624R02
(Remanufactured)



18-7616-1
CARBURETOR
4 Barrel - Rochester
Replaces: 1347-8288A1, 1347-804626R02
(Remanufactured)



18-7617-1
CARBURETOR
4 Barrel - Rochester
Replaces: 1347-9863A3,
1347-804624R1, 1347-804625R02
(Remanufactured)



18-7618-1
CARBURETOR
4 Barrel - Rochester
Replaces: 1347-8289A1,
1347-804624R1, 1347-804624R02
(Remanufactured)



18-7619-1
CARBURETOR
4 Barrel - Rochester
Replaces: 1347-9142A2, 1347-8460A3
(Remanufactured)

APPLICATION CHART BEGINS ON NEXT PAGE

CARBURETOR APPLICATION

| Model | Year | # of Cyl. | Beginning Serial # | Ending Serial # | Original Carb. # | Replacement Carb. # | Mfg. Carb. | Carb Code & Model | Carb # |
|--------------------------------------|-----------|-----------|--------------------|-----------------|--------------------------|---------------------|----------------------|-------------------|-----------|
| 90 | 1970-1971 | L4 | 2851424 | 3225967 | 1351-4263A1 | 1347-818619 1 | 7040082 | R2/2GC | 18-7609-1 |
| 90 | 1972 | L4 | 3225868 | 3226957 | 1351-4263A2 | 1347-818619 1 | 7041369 | R2/2GC | 18-7609-1 |
| 110 | 1963-1966 | L4 | 1357370 | 2044033 | 1336-2076 | — | 7036543 | R2/2GC | 18-7609-1 |
| 120 | 1972-1973 | L4 | 3377341 | 3770649 | 1351-4263A3 | 1347-818619 1 | 7041369 | R2/2GC | 18-7609-1 |
| 120 | 1974-1975 | L4 | 3770650 | 4469865 | 1351-5202A1 | 1347-818619 1 | 7043182 | R2/2GC | 18-7609-1 |
| 120 | 1976-1978 | L4 | 4469866 | 5192048 | 1351-6065A2 | 1347-818619 1 | 7044182 | R2/2GC | 18-7609-1 |
| 120 | 1979-1982 | L4 | 5192049 | 6229717 | 1351-7354A1 | 1347-818619 1 | 17059054 | R2/2GC | 18-7609-1 |
| 120/2.5L | 1983-1989 | L4 | 6229718 | OC853255 | 1351-8480A2 | 1348-818621 1 | 17081060 | R2/2GC | 18-7610-1 |
| 140 | 1970 | L4 | 2816417 | 2911439 | 1351-4032A1 | 1347-818620 1 | 7040080 | R2/2GC | 18-7608-1 |
| 140 | 1970-1973 | L4 | 2911440 | 3771644 | 1351-4293A1 | 1347-818620 1 | 7040084 | R2/2GC | 18-7608-1 |
| 140 | 1974-1978 | L4 | 3771645 | 5157668 | 1351-5203A1 | 1347-818620 1 | 7043184 | R2/2GC | 18-7608-1 |
| 140 | 1979-1982 | L4 | 5157669 | 6229717 | 1351-7355A1 | 1347-818620 1 | 17059052 | R2/2GC | 18-7608-1 |
| 140/3.0L | 1983-1989 | L4 | 6229718 | OC856556 | 1351-8480A2 | 1348-818621 1 | 17081060 | R2/2GC | 18-7610-1 |
| 165 (6 Cyl) | 1970-1972 | L6 | 2770032 | 3354791 | 1351-4282A1 | 1347-818620 1 | 7040083 | R2/2GC | 18-7608-1 |
| 165 (6 Cyl) | 1972-1973 | L6 | 3354702 | 3774864 | 1351-4871A1 | 1347-818620 1 | 7042183 | R2/2GC | 18-7608-1 |
| 165 (6 Cyl) | 1974-1978 | L6 | 3774865 | 5178958 | 1351-5204A1 | 1347-818620 1 | 7043183 | R2/2GC | 18-7608-1 |
| 488, L4 Engine | 1983-1984 | — | 6170297 | 6916778 | 1347-8460 1347-9142A2 | — | 17081299 | R4/4ME | 18-7619-1 |
| 165 (6 Cyl) | 1979-1981 | L6 | 5178959 | 5813433 | 1351-7356A1 | 1347-818620 1 | 17059050 | R2/2GC | 18-7608-1 |
| 180/190 3.7L, L4 Engine | 1985-1989 | — | 6916779 | Later | 1347-8460 1347-9142A2 | — | 17081299 17083522 | R4/4ME R4/4ME | 18-7619-1 |
| 205/4.3LX | 1985-1991 | V-6 | OA331455 | OD714369 | 3304-9354A2 | 3304-9354A2 | N/A | R4/4MV | 18-7604-1 |
| 898/200/5.0L | 1987-95 | V-8 | OB525982 | OF600999 | 1389-9670A2 | 3310-807312A1 | N/A | M2/MERCARB | 18-7611-1 |
| 888 | 1971-1977 | V-8 | 3108723 | 4887829 | 1376-5659A1 | 1376-818622 1 | 7044185 | R2/2GC | 18-7603-1 |
| 228 | 1977-1978 | V-8 | 4765100 | 5069430 | 1347-6427A1 | 1347-9661A3 | 17057282 | R4/4MV | 18-7605-1 |
| 228 TR &MIE | 1977-1978 | V-8 | 4765100 | 5069430 | 1347-6438A1 | 1347-9661A3 | 17057283 | R4/4MV | 18-7605-1 |
| 228 | 1978-1981 | V-8 | 5069431 | 6021783 | 1347-7361A1 | 1347-9661A3 | 17059292 | R4/4MV | 18-7605-1 |
| 228 | 1982 | V-8 | 6021784 | 6218461 | 1347-8296A4 | 1347-9661A3 | 17080565 | R4/4MV | 18-7605-1 |
| 223/230/5.0LX | 1983-1995 | V-8 | 6218462 | OF600999 | 1347-9661A3 | 1347-9661A3 | 17080565 | R4/4MV | 18-7605-1 |
| 228 MIE | 1978-1982 | V-8 | 5069431 | 6040745 | 1347-7364A1 | 1347-9661A3 | 17059291 | R4/4MV | 18-7605-1 |
| 230 MIE | 1982-1987 | V-8 | 6040746 | OB788151 | 1347-8290A1 | 1347-9661A3 | 17080564 | R4/4MV | 18-7605-1 |
| 255 MIE (GM) | 1975-1978 | V-8 | 4175500 | 4924564 | 1347-5732A1 | 1347-8289A1 | 7044291 | R4/4MV | 18-7618-1 |
| 255 MIE (GM) | 1978 | V-8 | 4924565 | 5195908 | 1347-7062A1 | 1347-8289A1 | 17059289 | R4/4MV | 18-7618-1 |
| 255 MIE (GM) | 1979-1980 | V-8 | 5195909 | 5907057 | 1347-7365A1 | 1347-8289A1 | 17059289 | R4/4MV | 18-7618-1 |
| 260 MIE | 1980-1986 | V-8 | 5907058 | OB522505 | 1347-8289A1 | 1347-8289A1 | 17080562 | R4/4MV | 18-7618-1 |
| 260/5.7MIE | 1987-1993 | V-8 | OB522506 | OF024999 | 1347-966A4 | 1347-816373A4 | 17080561 | R4/4MV | 18-7615-1 |
| 255 | 1975-1976 | V-8 | 41745500 | 4767999 | 1347-5732A1 | 1347-8289A1 | 7044291 | R4/4MV | 18-7618-1 |
| 260 | 1978 | V-8 | 4908850 | 5060805 | 1347-6492A1 | 1347-816373A4 | 17057298 | R4/4MV | 18-7615-1 |
| 260 | 1978-1982 | V-8 | 5060806 | 6024393 | 1347-7362A1 | 1347-816373A4 | 17059288 | R4/4MV | 18-7615-1 |
| 260 | 1982-1986 | V-8 | 6024393 | OB525981 | 1347-8292A4 | 1347-816373A4 | 17080561 | R4/4MV | 18-7615-1 |
| 260/5.7L ALPHA | 1987-1993 | V-8 | OB525982 | OF000454 | 1347-9662A4 | 1347-816373A4 | 17080561 | R4/4MV | 18-7615-1 |
| 5.7L(2BBL) | 1996-1997 | V-8 | OF601000 | OK999999 | 3310-807312A1 | 3310-807312A1 | — | M2/MERCARB | 18-7611-2 |
| 5.7L (Gen II) | 1998-2004 | V-8 | OL010037 | OW300754 | 3310-864943101 | 3310-864943101 | N/A | M2/MERCARB | 18-7639 |
| 5.7L BRAVO (w/o High Rise Intake) | 1987-1991 | V-8 | OB525982 | OD617327 | 1347-9662A4 | 1347-816373A4 | 17080561 | R4/4MV | 18-7615-1 |
| 5.7L BRAVO (w/ High Rise Intake) | 1987-1991 | V-8 | OB525982 | OD617327 | 1347-8289A1 | 1347-8289A1 | 17080562 | R4/4MV | 18-7618-1 |
| 350 MAGNUM ALPHA | 1986-1991 | V-8 | OA635178 | OD617327 | 1347-8289A1 | 1347-8289A1 | 17080562 | R4/4MV | 18-7618-1 |
| 5.7L SKI | 1985-1993 | V-8 | OA338533 | OF025099 | 1347-9415T | 1347-9415T | 17085013 | R4/4MV | 18-7615-1 |
| 5.7L SKI(2BBL) | 1996-1997 | V-8 | OF775200 | OK999999 | 3310-807312A1 | 3310-807312A1 | — | M2/MERCARB | 18-7611-2 |



CARBURETOR APPLICATION

| Model | Year | # of Cyl. | Beginning Serial # | Ending Serial # | Original Carb. # | Replacement Carb. # | Mfg. Carb. | Carb Code & Model | Carb # |
|-----------------|-----------|-----------|--------------------|-----------------|------------------|---------------------|------------|-------------------|-----------|
| 300MR/TRS | 1985-1986 | V-8 | 6668677 | OB430367 | 1347-7498A7 | 1347-7498A7 | 17059280 | R4/4MV | 18-7615-1 |
| 330 MCM | 1977-1978 | V-8 | 4623115 | 5027230 | 1347-6493A1 | 1347-8291A3 | 17057287 | R4/4MV | 18-7616-1 |
| 330 MCM | 1977-1981 | V-8 | 5027231 | 6083144 | 1347-7363A1 | 1347-8291A3 | 17059290 | R4/4MV | 18-7616-1 |
| 330 MCM | 1982-1987 | V-8 | 6083145 | OB816540 | 1347-8291A3 | 1347-8291A3 | 1708563 | R4/4MV | 18-7616-1 |
| 330 MIE | 1977-1978 | V-8 | 4623115 | 5226384 | 1347-6493A1 | 1347-8288A1 | 17057287 | R4/4MV | 18-7616-1 |
| 330 MIE | 1979-1980 | V-8 | 5226385 | 5889913 | 1347-7366A1 | 1347-8288A1 | 17059287 | R4/4MV | 18-7616-1 |
| 340/7.4L MIE | 1981-1992 | V-8 | 5889914 | OD715493 | 1347-8288A1 | 1347-8288A1 | 17080560 | R4/4MV | 18-7616-1 |
| 7.4L MIE | 1995-1997 | V-8 | OF350000 | OK999999 | 3310-806969A1 | 3310-806969A1 | 9780 | WEBER | 18-7613-1 |
| 7.4L BRAVO I/II | 1988-1991 | V-8 | OB771113 | OD603117 | 1347-8291A3 | 1347-8291A3 | 17080563 | R4/4MV | 18-7616-1 |
| 7.4L BRAVO I/II | 1995-1997 | V-8 | OF352000 | OK999999 | 3310-806969A1 | 3310-806969A1 | 9780 | WEBER | 18-7613-1 |
| 7.4L BRAVO III | 1996-1997 | V-8 | OF800700 | OK999999 | 3310-806969A1 | 3310-806969A1 | 9780 | WEBER | 18-7613-1 |
| 370/400 | 1978-1987 | V-8 | 4179554 | OB714586 | 1347-7498A2 | 1347-9863A3 | 17059280 | R4/4MV | 18-7617-1 |
| 454 MAG ALPHA | 1986-1988 | V-8 | OA631894 | OB785148 | 1347-8291A3 | 1347-8291A3 | 17080563 | R4/4MV | 18-7616-1 |
| 454 MAG BRAVO | 1988-1992 | V-8 | OB721206 | OD808068 | 1347-7498A2 | 1347-9863A3 | 17059280 | R4/4MV | 18-7617-1 |

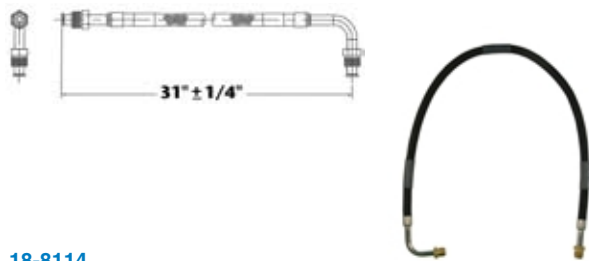

18-8114
FUEL LINE HOSE

For fuel pump to carburetor connection. Replaces copper or steel tubing 3/8" X 31" PTFE composite hose with 5/8"-18 male inverted flare straight one end, 5/8"-18 90° one end. SAE J1527 type A1

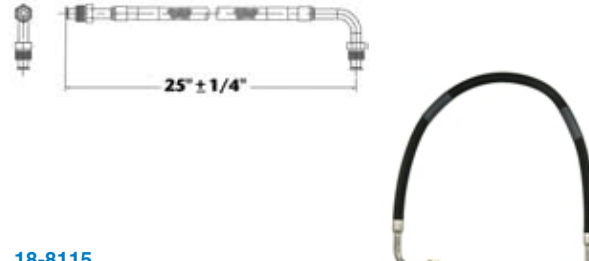

18-8115
FUEL LINE HOSE

For fuel pump to carburetor connection. Replaces copper or steel tubing 3/8" X 25" PTFE composite hose with 5/8"-18 male inverted flare straight one end, 5/8"-18 90° one end. SAE J1527 type A1

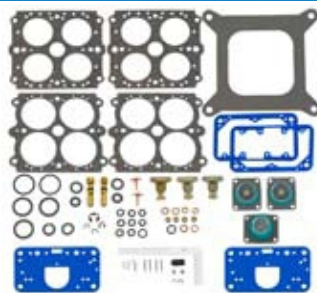

18-7751
CARB KIT

Replaces: 13220

Fits: GM 420 V8 454 (1987-89), GM 425 V8 454 (1990-93), GM 425 (Gen V) V8 454 (1992-93), 440 TRS GM 454 (1983-86), GM 450 V8 454 (1995-96), 460 TRS V8 482 (1983-86), GM 465 V8 502 (1990-92), GM 465 (Gen V) V8 502 (1992-94), 500 (Gen+) GM 502 V8 (1999), 500 (Gen V) 502 V8 (1994-98), 500 Bulldog 540 V8 (1990-01)



18-7071
CARB KIT

Replaces: 1397-3458



18-7075
CARB KIT











Replaces: 1397-5830, 1397-7099, 1397-8760, 1397-5831

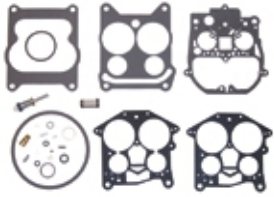

18-7070
CARB KIT

Replaces: 1397-2072, 1397-7542, 1397-2637, 1397-7543, 1397-8872, 1397-3464,

APPLICATION CHART BEGINS ON PAGE 614

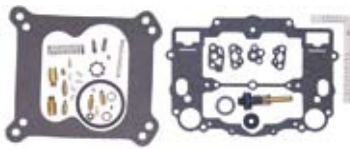
| | | |
|--|---|---|
|  <p>18-7072 CARB KIT Replaces: 1397-3306, 1397-4329, 1397-5635, 1397-6638, 823426A1</p> |  <p>18-7076 CARB KIT Replaces: 1397-6367, A1</p> |  <p>18-7077 CARB KIT Replaces: 1397-8952, 823426A1</p> |
|  <p>18-7078 CARB KIT Replaces: 1397-2605</p> |  <p>18-7080 CARB KIT Replaces: 1398-3089</p> |  <p>18-7081 CARB KIT Replaces: 1396-4656 Contains adjustable needles and seats</p> |
|  <p>18-7095 CARB KIT Replaces: 1397-7539, 1397-7540, 1397-7544, 1397-8535, 1397-9723</p> |  <p>18-7096 CARB KIT Replaces: 1396-5238, 1396-5222 Contains adjustable needles and seats</p> |  <p>18-7097 CARB KIT Replaces: 3302-9437, 3302-804845 MerCarb 2 bbl. bottom fill accelerator pump 1983-1986 MCM 120, 140, 470, 185, 200, 898.</p> |
|  <p>18-7098-1 CARB KIT Replaces 3302-804844002 MerCarb 2 bbl. side fill accelerator pump 1986 and UP MCM 4-cyl., V6 & V8</p> |  <p>18-7728 CARB KIT</p> |  <p>18-7749 CARB KIT Replaces: 809065, 835076, 823728</p> |

APPLICATION CHART BEGINS ON NEXT PAGE

MERCUISER

Fuel System



| | | |
|--|---|---|
|  <p>18-7748 CARB KIT Replaces: 809064</p> |  <p>18-7746 CARB KIT Replaces: 823427A1 Repair Kit for 2 BBL Rochester</p> |  <p>18-7200 FLOAT Replaces: 1397-2060 (Alcohol Resistant) Plastic</p> |
|  <p>18-7201 FLOAT Replaces: 1397-3327, 1397-8546, 1397-8959 (Alcohol Resistant) Brass</p> |  <p>18-7202 FLOAT Replaces: 1397-5837, 3302-9031 (Alcohol Resistant) Brass</p> |  <p>18-7206 FLOAT Replaces: 1396-4088 Nitrophyl</p> |
| <p>NEW</p>  <p>18-7666 CHOKE PULL-OFF Replaces: 1397-8582 Rochester 4V carburetors</p> | <p>NEW</p>  <p>18-7664 CHOKE THERMOSTAT Replaces: 809066 Weber 4V Carburetors with electric choke</p> | <p>NEW</p>  <p>18-7665 CHOKE THERMOSTAT Replaces: 70125A 1 Rochester & Mercarb 2V with electric choke</p> |
| <p>NEW</p>  <p>18-7667 CHOKE THERMOSTAT Replaces: 71464A01 Rochester Carburetors with divorced choke</p> |  <p>18-7227 CHOKE THERMOSTAT Replaces: 1396-4148 For Holley Carburetor</p> |  <p>18-2641 VAPOR SEPARATOR TANK O-RING Replaces: 808500</p> |

CARBURETOR KIT/FLOAT APPLICATION

| Model & Serial # | Mercruiser Carb. # | Mfg. Carb. # | Carb. Code & Model | Carb. Kit ① | Float |
|------------------------------------|--------------------|--------------|--------------------|-------------|---------|
| MCM 80 ALL | 1346-2770 | RBS-4394S | C1/RBS | 18-7080 | — |
| MCM 90 | | | | | |
| 3225967 & BELOW | 1351-4263A1 | 7040082 | R2/2GC | 18-7746 | 18-7200 |
| 3225968 & ABOVE | 1351-4263A2 | 7041369 | R2/2GC | 18-7746 | 18-7200 |
| MCM110 ALL | 1336-2076 | 7036543 | R2/2GC | 18-7070 | 18-7200 |
| MCM 120/2.5L | | | | | |
| 2520424 & BELOW | 1336-2076 | 7036543 | R2/2GC | 18-7746 | 18-7200 |
| 2520425-3377340 | 1336-3594A1 | 7036543 | R2/2GC | 18-7746 | 18-7200 |
| 3377341-3770649 | 1351-4263A3 | 7041369 | R2/2GC | 18-7746 | 18-7200 |
| 3770650-4469865 | 1351-5202A1 | 7043182 | R2/2GC | 18-7746 | 18-7200 |
| 4469866-5192047 | 1351-6065A2 | 7044182 | R2/2GC | 18-7746 | 18-7200 |
| 5192048-6229717 | 1351-7354A1 | 17059054 | R2/2GC | 18-7746 | 18-7200 |
| 6229718 & ABOVE | 1351-8480A2 | 17081060 | R2/2GC | 18-7746 | 18-7200 |
| 6229718 & ABOVE | 1389-8490A2 | N/A | M2/Mercarb | 18-7097 | 18-7202 |
| 6229718 & ABOVE | 1389-9350A2 | N/A | M2/Mercarb | 18-7097 | 18-7202 |
| 6229718 & ABOVE | 1389-9562A1 | N/A | M2/Mercarb | 18-7098-1 | 18-7202 |
| MCM 140 /3.0L/3.0LX(4 cyl.) | | | | | |
| 2816416 & BELOW | 1351-3635A1 | 7036646 | R2/2GC | 18-7746 | 18-7200 |
| 2816417-3332137 | 1351-4032A1 | 7040080 | R2/2GC | 18-7746 | 18-7200 |
| 3332138-3771644 | 1351-4293A1 | 7040084 | R2/2GC | 18-7746 | 18-7200 |
| 3771645-5157668 | 1351-5203A1 | 7043184 | R2/2GC | 18-7746 | 18-7200 |
| 5157669-6229717 | 1351-7355A1 | 17059052 | R2/2GC | 18-7746 | 18-7200 |
| 6229718-C856558 | 1351-8480A2 | 17081060 | R2/2GC | 18-7746 | 18-7200 |
| 6229718-C856558 | 1389-8490A2 | N/A | M2/Mercarb | 18-7097 | 18-7202 |
| 6229718-C856558 | 1389-9350A2 | N/A | M2/Mercarb | 18-7097 | 18-7202 |
| 6229718-C856558 | 1389-9562A1 | N/A | M2/Mercarb | 18-7098-1 | 18-7202 |
| C856559 & ABOVE | 1389-815396A2 | N/A | M2/Mercarb | 18-7098-1 | 18-7202 |
| C856559 & ABOVE | 1389-815397A2 | N/A | M2/Mercarb | 18-7098-1 | 18-7202 |
| MCM 140 (6 cyl) | | | | | |
| ALL (BC) | 1338-2161 | 7025638 | R1/BC | 18-7071 | — |
| ALL (B) | 1338-2166 | 7025662 | R1/B | 18-7071 | — |
| MCM 150 | | | | | |
| 1823489 & BELOW | 1338-2428 | 7024180 | R1/BC | 18-7071 | — |
| 1823489 & BELOW | 1338-2431 | 7024181 | R1/B | 18-7071 | — |
| 1823490-1830151 | 1338-2608 | 7025183 | R1/BC | 18-7071 | — |
| 1823490-1830151 | 1338-2609 | 7025184 | R1/B | 18-7071 | — |
| 1830152 & ABOVE | 1338-2633 | 7025188 | R2/2GC | 18-7070 | 18-7200 |
| MCM 160 | | | | | |
| 2492035 & BELOW | 1338-2991 | 7026088 | R2/2GC | 18-7746 | 18-7200 |
| 2492036 & ABOVE | 1351-3635A1 | 7036646 | R2/2GC | 18-7746 | 18-7200 |
| MCM 165 (6 cyl) | | | | | |
| 3354701 & BELOW | 1351-4282A1 | 7040083 | R2/2GC | 18-7746 | 18-7200 |
| 3354702-3774864 | 1351-4871A1 | 7042183 | R2/2GC | 18-7746 | 18-7200 |
| 3774865-5178958 | 1351-5204A1 | 7043183 | R2/2GC | 18-7746 | 18-7200 |
| 5178959 & ABOVE | 1351-7356A1 | 17059050 | R2/2GC | 18-7746 | 18-7200 |
| MCM 165/170/3.7L (4 cyl) | | | | | |
| 6218037-6916778 | 1389-8489A5 | N/A | M2/Mercarb | 18-7097 | 18-7202 |
| 6916779 & ABOVE | 1389-9564A1 | N/A | M2/Mercarb | 18-7098-1 | 18-7202 |
| MCM 175/4.3L/185 (V-6) | | | | | |
| (229 CID) ALL | 3304-9565A1 | N/A | M2/Mercarb | 18-7098-1 | 18-7202 |
| A221455-D714106 | 3300-8886A2 | 17083515 | R4/4MV | 18-7095 | 18-7201 |
| 185 (262 CID) | | | | | |
| A221455-B527954 | 3304-9353A2 | N/A | M2/Mercarb | 18-7097 | 18-7202 |
| MCM 205 (262 CID) | | | | | |
| A331455-D714369 | 3304-9354A2 | — | R4/4MV | 18-7095 | 18-7201 |
| | 3304-9565A1 | N/A | M2/Mercarb | 18-7098-1 | 18-7202 |

① Does not include metering rods



CARBURETOR KIT/FLOAT APPLICATION (Cont.)

| Model & Serial # | Mercruiser Carb. # | Mfg. Carb. # | Carb. Code & Model | Carb. Kit ① | Float |
|------------------------------------|--------------------|--------------|--------------------|-------------|---------|
| MCM/MIE 470 ALL | 1376-5990A1 | 17057132 | R2/2GC | 18-7076 | 18-7202 |
| MCM 485 ALL | 1376-5990A1 | 17057132 | R2/2GC | 18-7076 | 18-7202 |
| MCM 488 ALL | 1347-8460A3 | 17081299 | R4/4ME | 18-7077 | 18-7201 |
| MCM 888 | | | | | |
| ALL HOLLEY | 1356-4642 | D1JJ-9510-8 | H2/2300 | 18-7081 | 18-7206 |
| ALL ROCHESTER | 1376-5659A1 | 7044185 | R2/2GC | 18-7075 | 18-7202 |
| MCM 180/190/3.7LX (4 cyl) | | | | | |
| | 1347-9142A2 | 17083522 | R4/4MV | 18-7095 | 18-7201 |
| MIE 198/200/5.0L | | | | | |
| 6021383 & BELOW | 1376-6491A1 | 17057139 | R2/2GV | 18-7075 | 18-7202 |
| 6021384 & ABOVE | 1376-8295A3 | 17080350 | R2/2GV | 18-7075 | 18-7202 |
| MCM 200 (6 cyl) | | | | | |
| 2494935 & BELOW | 1347-3237A2 | 7037082 | R4/4MV | 18-7072 | 18-7201 |
| 2494936 & ABOVE | 1347-3237A4 | 7037082 | R4/4MV | 18-7072 | 18-7201 |
| MCM 898/200/5.0L | | | | | |
| 6218462 & ABOVE | 1389-8488A2 | N/A | M2/Mercarb | 18-7097 | 18-7202 |
| 6218462 & ABOVE | 1389-9563A1 | N/A | M2/Mercarb | 18-7098-1 | 18-7202 |
| 6218462 & ABOVE | 1389-9670A2 | N/A | M2/Mercarb | 18-7098-1 | 18-7202 |
| MCM 205/4.3LX (V-6 262 CID) | | | | | |
| A331455-D714369 | 3304-9354A2 | 17084516 | R4/4MV | 18-7095 | 18-7201 |
| MCM/MIE 215 ALL | 1356-4066 | C9FF-9510-E | H4/4160 | 18-7096 | 18-7206 |
| MCM/MIE 225 (FORD) | | | | | |
| ALL | 1356-5155 | D2JL-9510-C | H4/4160 | 18-7096 | 18-7206 |
| MCM/MIE 225 (GM) | 1337-2103 | 7025564 | R4/4GC | 18-7078 | — |
| 1536920-2694014 | 1337-2604 | 7025756 | R4/4GC | 18-7078 | — |
| | 1347-3353 | 7037082 | R4/4MV | 18-7072 | 18-7201 |
| | 1347-3237A3 | 7037082 | R4/4MV | 18-7072 | 18-7201 |
| MCM 228 | | | | | |
| 5069430 & BELOW | 1347-6427A1 | 17057282 | R4/4MV | 18-7072 | 18-7201 |
| MCM 228TR/ MIE 228 | | | | | |
| 5069430 & BELOW | 1347-6438A1 | 17057283 | R4/4MV | 18-7072 | 18-7201 |
| MCM 228/230/5.0L | | | | | |
| 5069431-6021783 | 1347-7361A1 | 17059292 | R4/4MV | 18-7095 | 18-7201 |
| 6021784-6218461 | 1347-8296A4 | 17080565 | R4/4MV | 18-7095 | 18-7201 |
| 6218462 & ABOVE | 1347-9661A3 | — | R4/4MV | 18-7095 | 18-7201 |
| MIE 228 | | | | | |
| 5067431-6040745 | 1347-7364A1 | 17059291 | R4/4MV | 18-7095 | 18-7201 |
| 6040746 & ABOVE | 1347-8290A1 | 17080564 | R4/4MV | 18-7095 | 18-7201 |
| MIE 230/5.0L ALL | 1347-8290A1 | 17080564 | R4/4MV | 18-7095 | 18-7201 |
| 230/5.0LX | 1347-9661A3 | — | R4/4MV | 18-7095 | 18-7201 |
| MCM/MIE 233 | | | | | |
| 4465029 & BELOW | 1376-5744A1 | 7044187 | R2/2GC | 18-7075 | 18-7202 |
| 4465030 & ABOVE | 1376-6152A1 | 17056197 | R2/2GC | 18-7075 | 18-7202 |
| MCM/MIE 250 AUTO. CHOKE | | | | | |
| 4767999 & BELOW | 1347-3353 | 7037082 | R4/4MV | 18-7072 | 18-7201 |
| MCM/MIE 250 (EL. CHOKE) | | | | | |
| 4767999 & BELOW | 1347-3237A3 | 7037082 | R4/4MV | 18-7072 | 18-7201 |
| MCM 250 | | | | | |
| 4768000 & ABOVE | 1347-6492A1 | 17057298 | R4/4MV | 18-7072 | 18-7201 |
| MCM/MIE 255 (GM) | | | | | |
| 4924564 & BELOW | 1347-5732A1 | 7044291 | R4/4MV | 18-7072 | 18-7201 |
| 4924565-5195908 | 1347-7062A1 | 17057295 | R4/4MV | 18-7072 | 18-7201 |
| 5195909-5907067 | 1347-7365A1 | 17059289 | R4/4MV | 18-7095 | 18-7201 |
| 5907068 & ABOVE | 1347-8289A1 | 17080562 | R4/4MV | 18-7095 | 18-7201 |
| MCM/MIE 255 (FORD) | | | | | |
| ALL | 1356-5169 | D2JL-9510E | H4/4160 | 18-7096 | 18-7206 |

① Does not include metering rods

| CARBURETOR KIT/FLOAT APPLICATION (Cont.) | | | | | |
|--|--------------------|--------------|--------------------|-------------|---------|
| Model & Serial # | Mercruiser Carb. # | Mfg. Carb. # | Carb. Code & Model | Carb. Kit ① | Float |
| MCM 260/5.7L BRAVO | | | | | |
| 5060805 & BELOW | 1347-6492A1 | 17057298 | R4/4MV | 18-7072 | 18-7201 |
| 5060806-6024393 | 1347-7362A1 | 17059288 | R4/4MV | 18-7095 | 18-7201 |
| 6024394-B525981 | 1347-8292A4 | 17080561 | R4/4MV | 18-7095 | 18-7201 |
| B525982 & ABOVE | 1347-9662A4 | — | R4/4MV | 18-7095 | 18-7201 |
| MIE 260/5.7L 350 MAG | | | | | |
| A635178-D617327 | 1347-8289A1 | 17080562 | R4/4MV | 18-7095 | 18-7201 |
| MIE 5.7 SKI | | | | | |
| A339533-F205099 | 1347-9415T | 17085013 | R4/4MV | 18-7095 | 18-7201 |
| MCM/MIE 270 ALL | 1347-4180A1 | 7029285 | R4/4MV | 18-7072 | 18-7201 |
| MCM 280 | | | | | |
| 4176468 & BELOW | 1347-4179A2 | 7040283 | R4/4MV | 18-7072 | 18-7201 |
| 4176469 & ABOVE | 1347-5981A1 | 7044290 | R4/4MV | 18-7072 | 18-7201 |
| MCM 300 MR/TRS (GM) | | | | | |
| 6668677 & ABOVE | 1347-7498A7 | — | R4/4MV | 18-7095 | 18-7201 |
| MCM/MIE 325 AUTO. CHOKE | | | | | |
| 3042730 & BELOW | 1347-3342 | 7027080 | R4/4MV | 18-7072 | 18-7201 |
| 3042731 & ABOVE | 1347-4533A1 | 7041831 | R4/4MV | 18-7072 | 18-7201 |
| MCM/MIE 325 EL. CHOKE | | | | | |
| 2278747-378099 | 1347-3689A1 | 7029280 | R4/4MV | 18-7072 | 18-7201 |
| MCM 330/454 MAGNUM (ALPHA ONE) | | | | | |
| 5027230 & BELOW | 1347-6493A1 | 17057287 | R4/4MV | 18-7072 | 18-7201 |
| 5027231-6083144 | 1347-7363A1 | 17059290 | R4/4MV | 18-7095 | 18-7201 |
| 6083145 & ABOVE | 1347-8291A3 | 17080563 | R4/4MV | 18-7095 | 18-7201 |
| MIE 330 | | | | | |
| 5226384 & BELOW | 1347-6493A1 | 17057287 | R4/4MV | 18-7072 | 18-7201 |
| 5226385 & ABOVE | 1347-7366A1 | 17059287 | R4/4MV | 18-7095 | 18-7201 |
| MIE 340/7.4L | | | | | |
| ALL | 1347-8288A1 | 17080560 | R4/4MV | 18-7095 | 18-7201 |
| MCM 350 MAGNUM/5.7L BRAVO | | | | | |
| B525992-317327 | 1347-8289A1 | — | R4/4MV | 18-7095 | 18-7201 |
| MIE 350 ALL | 1347-5326A2 | 17065977 | R4/4MV | 18-7072 | 18-7201 |
| MCM 370/400 ALL | 1347-7498A2 | 17059280 | R4/4MV | 18-7095 | 18-7201 |
| MCM 7.4L (BRAVO ONE) | 1347-8291A3 | 17080563 | R4/4MV | 18-7095 | 18-7201 |
| MCM 454 7.4L | | | | | |
| 6083145-B816540 | — | — | H4/4150, R6647A | 18-7728 | — |
| MCM 454 MAGNUM (BRAVO ONE) | | | | | |
| ALL | 1347-7498A2 | 17059280 | R4/4MV | 18-7095 | 18-7201 |
| | 1347-9863A3 | — | R4/4MV | 18-7095 | 18-7201 |
| MCM 502 MAGNUM (BRAVO ONE) | | | | | |
| C878221-D857199 | 1347-814623A2 | — | R4/4MV | 18-7095 | 18-7201 |
| MCM 8.2L | 1347-814623A2 | — | R4/4MV | 18-7095 | 18-7201 |

① Does not include metering rods



ANODIZED ALUMINUM FLAME ARRESTOR SPECIFICATIONS

| ENGINE | PART NO. | HEIGHT A | ELEMENT B | THROAT C | VENT TUBES* |
|----------------|-----------|----------|-----------|----------|-------------|
| 4 & 6 cyl. | 18-7228 | 2.156 | 1.088 | 3.120 | 1 |
| 4 & 6 cyl. | ① 18-7234 | 2.280 | 1.550 | 3.100 | 0 |
| V-8 | 18-7229 | 2.250 | 1.470 | 5.050 | 0 |
| V-8 | 18-7230 | 2.250 | 1.470 | 5.050 | 1 |
| V-8 | 18-7231 | 2.250 | 1.470 | 5.050 | 2 |
| Hi-Performance | 18-7232 | 2.969 | 2.190 | 5.050 | 2 |

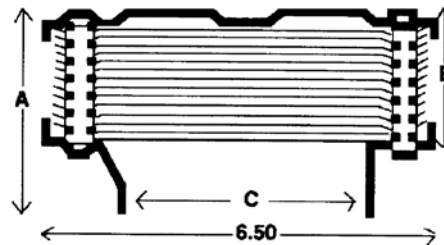

① 7" Outside diameter * Vent tubes accept 5/8 inch ID hose

ALL SIERRA FUEL PUMPS INCLUDE MOUNTING GASKET



18-7256
FUEL PUMP
Flange I.D. # 6790,M3530
Replaces: 32722
For: GM (4 & 6 Cyl.)153, 230, 250, 292



18-7265
FUEL PUMP
Flange I.D. # 41412,M73018
For GM (V-8) 305, 350, 400



18-7266
FUEL PUMP
Flange I.D. # 41413, M6696
For: Ford (V-8) 302, 351

APPLICATION CHART BEGINS ON PAGE 620



18-7267
FUEL PUMP
Flange I.D. # 41414
Replaces: 62092,T
For Ford (V-8) 302



18-7269
FUEL PUMP
Flange I.D. # 41416
For: GM (V-8) 454



18-7274
FUEL PUMP
Flange I.D. # 41421, M73021
Replaces: 86246
For: GM (V-8) 305, 350, 400



18-7275
FUEL PUMP
Flange I.D. # 41422
Replaces: 86247,T
For: GM (V-8) 454



18-7278
FUEL PUMP
Flange I.D. # M60032
Replaces: 86234A4
For: GM (4 & 6 Cyl.) 153, 181,
224, 225, 250



18-7282
FUEL PUMP
Flange I.D. # M60337
Replaces: 42725A3
For: GM (V-6) 225



18-7283
FUEL PUMP
Flange I.D. # M60600
Replaces: 97401A2, 97401A2A8,
861678A1
For: GM (V-8) 305, 350



18-7284
FUEL PUMP
Flange I.D. # M60315
Replaces: 41141A2,862077A1
For: GM (V-6) 231, 262

APPLICATION ON NEXT PAGE



**18-7288
FUEL PUMP**

Flange I.D. #60601
Replaces: 812454A1, 862048A1
For: Inline (4 cyl) 120, 140, 3.0L and 224 CID



**18-7326
ELECTRIC FUEL PUMP**

Replaces: 805656A2
For: 1992-93, 1996
F.I. & Carbureted 4.3L
with inline electric pump

FUEL PUMP APPLICATION

| Model | Serial Number | Fuel Pump | Model | Serial Number | Fuel Pump |
|-----------------------|-------------------|-----------|--------------------------|-------------------|-----------|
| 120 | 1666601 - 3377340 | 18-7278 | 230/5.0L-LX GM | B525982 & Up | 18-7283 |
| 120 | 4469866 & Below | 18-7278 | 233 FORD | 4500860 & Up | 18-7267 |
| 120 | 4469866 - 4952700 | 18-7278 | 250 GM | 4768000 - 4908849 | 18-7274 |
| 120 | 4952701 & Up | 18-7278 | 255 FORD | 3258728 & Up | 18-7267 |
| 120 | 5192049 - 6229717 | 18-7278 | 255 GM | 4175500 - 5195908 | 18-7274 |
| 120/2.5L | 6229718 & Up | 18-7278 | 255 GM | 5195909 & Up | 18-7274 |
| 120/2.5L | 6229718 & Up | 18-7282 | 260 GM | 4908850 - 6218461 | 18-7274 |
| 140 (4 Cyl.) | 2508261 - 3332137 | 18-7278 | 260 GM | 6218461 & Up | 18-7283 |
| 140 | 4460664 & Below | 18-7278 | 260/5.7 GM | B525982 & Up | 18-7283 |
| 140 | 4460665-4918569 | 18-7278 | 260 GM Inboard | 5907058 & Up | 18-7283 |
| 140 | 4918570 & Up | 18-7278 | 260/5.7L GM (IB) | 5907058 & Up | 18-7283 |
| 140 (4 Cyl.) | 5157669 - 6229717 | 18-7278 | 5.7L-GM | F025000 & Up | 18-7283 |
| 140/3.0L | 6229717 & Below | ① 18-7278 | 280 GM | 4176250 & Up | 18-7274 |
| 140/3.0L | 6229718 & Up | 18-7282 | 300MR/TRS GM | 6668677 & Up | 18-7283 |
| 3.0L/3.0LX | C856559 & Up | 18-7282 | 325-GM | 2278747 - 3640670 | 18-7275 |
| 140 (6 Cyl.) | 1538930 - 1725960 | 18-7256 | 330 GM | 4623115 & Up | 18-7275 |
| 150 | 1666495 - 2048046 | 18-7256 | 330 GM/W.B.W. | 6083145 & Up | 18-7288 |
| 160 | 2048022 - 2770031 | 18-7278 | 340/7.4L-GM (IB) | 5889914 & Up | 18-7288 |
| 165 | 4471566-4884834 | 18-7278 | 350 GM | 3780450 & Up | 18-7275 |
| 165 | 5178959 & Up | 18-7278 | 350-GM (MAGNUM) | A635178 & Up | 18-7283 |
| 165/3.7L (4 Cyl.) | 6916779 & Up | 18-7282 | 350 (MAG-TOURNEY SKI) | D505450 & Up | 18-7283 |
| 170 (4 Cyl.) | 6916779 & Up | 18-7282 | 370 TRS-GM | 6721528 & Up | 18-7288 |
| 180/3.7-LX (4 Cyl.) | 6916779 & Up | 18-7282 | 390-GM | 2781129 - 2825059 | 18-7275 |
| 175/4.3L (262 CID) | B527955 & Up | 18-7284 | 420-GM | A398941 & Up | 18-7288 |
| 185 (229 CID) | 6330183 & Up | 18-7284 | 425-GM | A398941 & Up | 18-7288 |
| 185 (262 CID) | A331455 & Up | 18-7284 | 454 GM (MAGNUM) | A631894 & Up | 18-7288 |
| 190 (4 Cyl.) | 6916779 & Up | 18-7282 | 454 MAG. BRAVO GM | B840126 & Up | 18-7288 |
| 200 | 2453769 - 2712072 | 18-7278 | 470 | 5097479 & Below | 18-7278 |
| 200 GM | 6218462 & Up | 18-7283 | 470 | 5097480 & Up | 18-7278 |
| 200/5.0L GM | B525982 & Up | 18-7283 | 470 | 5520115 - 6218036 | 18-7278 |
| 205 (262 CID) | A331455 & Up | 18-7284 | 470 | 6218037 & Up | 18-7278 |
| 205/4.3L-LX (262 CID) | B527955 & Up | 18-7284 | 485 | 5685394 & Up | 18-7278 |
| 215 Ford | 3085036 & Below | 18-7267 | 488 | 6170297 & Up | 18-7278 |
| 215 Ford | 3258182 & Up | 18-7267 | 888 Ford | 3108723 & Up | 18-7267 |
| 225 Ford | 3385721 & Up | 18-7267 | 898/198-GM | 4762210 - 6218461 | 18-7274 |
| 228 GM | 4765100 - 5170008 | 18-7274 | 898 GM | 6218462 & Up | 18-7283 |
| 228 GM | 5170009 - 6218461 | 18-7274 | 5.7 GM (SKI) | A338553 & Up | 18-7283 |
| 228 GM | 6218462 & Up | 18-7283 | 5.7 GM (SKI) | B514627 & Up | 18-7283 |
| 230 GM Inboard | 5907058 & Up | 18-7283 | 5.7L BRAVO (GM)350 | B525982 & Up | 18-7283 |
| 230/5.0L-GM (IB) | B522506 & Up | 18-7283 | 7.4L BRAVO GM | B771113 & Up | 18-7288 |
| 230 GM | 6218462 & Up | 18-7283 | 7.4L W/HURTH (IB) | C391564 & Up | 18-7288 |

① Old Design

FUEL WATER SEPARATORS

Sierra fuel water separators remove over 99.8% of emulsified water from your gasoline. Sierra's 10 micron filters are over 90% efficient at removing particles as small as 10 micron. All filters flow @ 90 GPH to feed even the hungriest motor. Sierra 10 micron filters are recommended to prevent damage to sensitive inboard and outboard fuel injection systems.

- UNIVERSAL DESIGN -
DIRECT REPLACEMENT FOR MERCURY AND YAMAHA

FUEL WATER SEPARATOR BRACKETS



| Bracket Type | Part # | Replaces | Bracket Type | Part # | Replaces |
|----------------------|---------|----------|---------------|-----------|-----------------|
| 1/4" Stainless Steel | 18-7777 | | 1/4" Aluminum | 18-7853-1 | Mercury 89876A3 |
| 3/8" Stainless Steel | 18-7776 | | 3/8" Aluminum | 18-7775 | |

FUEL WATER SEPARATOR KITS



21 MICRON FILTER KITS - FOR CARBURETED ENGINES

| Kit Type | Part # | Micron Rating | Contents | Replaces |
|--|-----------|---------------|---|--|
| 1/4" Aluminum (Short Filter) | 18-7848-1 | 21 | 1 - 18-7844 filter & 1 18-7853-1 bracket 2 - 18-4256 1/4" pipe plugs | Mercury - 35-802893A4, Q4, 35-60494A4 |
| 1/4" Aluminum Bonus Pack Contains spare filter | 18-7848-2 | 21 | 2 - 18-7844 filter & 1 18-7853-1 bracket 2 - 18-4256 1/4" pipe plugs | |
| 1/4" Aluminum (Tall Filter) | 18-7852-1 | 21 | 1 - 18-7845 filter & 1 18-7853-1 bracket 2 - 18-4256 1/4" pipe plugs | |
| 1/4" Aluminum Bonus Pack Contains spare filter | 18-7852-2 | 21 | 2 - 18-7845 filter & 1 18-7853-1 bracket 2 - 18-4256 1/4" pipe plugs | |
| 3/8" Aluminum (Tall Filter) | 18-7775-1 | 21 | 1 - 18-7845 filter & 1 18-7775 bracket 2 - 18-4264 3/8" pipe plugs | |
| 1/4" Stainless Steel (Tall Filter) | 18-7777-1 | 21 | 1 - 18-7845 filter & 1 18-7777 bracket 2 - 18-4256 1/4" pipe plugs | |
| 3/8" Stainless Steel (Tall Filter) | 18-7776-1 | 21 | 1 - 18-7845 filter & 1 18-7776 bracket 2 - 18-4264 3/8" pipe plugs | |



10 MICRON FILTER KITS FOR FUEL INJECTED ENGINES

| Kit Type | Part # | Micron Rating | Contents |
|--|-----------|---------------|---|
| 1/4" Aluminum (Short Filter) | 18-7983-1 | 10 | 1 - 18-7944 filter & 1 18-7853-1 bracket 2 - 18-4256 1/4" pipe plugs |
| 1/4" Aluminum Bonus Pack Contains spare filter | 18-7983-2 | 10 | 2 - 18-7944 filter & 1 18-7853-1 bracket 2 - 18-4256 1/4" pipe plugs |
| 1/4" Aluminum (Tall Filter) | 18-7982-1 | 10 | 1 - 18-7945 filter & 1 18-7853-1 bracket 2 - 18-4256 1/4" pipe plugs |
| 1/4" Aluminum Bonus Pack Contains spare filter | 18-7982-2 | 10 | 2 - 18-7945 filter & 1 18-7853-1 bracket 2 - 18-4256 1/4" pipe plugs |
| 1/4" Aluminum (High Capacity Filter) | 18-7966-1 | 10 | 1 - 18-7866 filter & 1 18-7853-1 bracket 2 - 18-4256 1/4" pipe plugs |
| 3/8" Aluminum (Tall Filter) | 18-7986-1 | 10 | 1 - 18-7945 filter & 1 18-7775 bracket 2 - 18-4264 3/8" pipe plugs |
| 1/4" Stainless Steel (Tall Filter) | 18-7984-1 | 10 | 1 - 18-7945 filter & 1 18-7777 bracket 2 - 18-4256 1/4" pipe plugs |
| 3/8" Stainless Steel (Tall Filter) | 18-7985-1 | 10 | 1 - 18-7945 filter & 1 18-7776 bracket 2 - 18-4264 3/8" pipe plugs |



10 MICRON FILTER KITS WITH DRAIN BOWLS

Sierra AquaVue™ and metal bowl separator filters allow water to be drained from the filter to extend service life. Use the AquaVue™ bowl for outboard, above deck installations. USCG regulations require the use of the flame resistant metal bowl below deck.

| Kit Type | Part # | Micron Rating | Contents |
|--|---------|---------------|--|
| 1/4" Aluminum w/ metal drain bowl | 18-7951 | 10 | 1 - 18-7919 filter & 1 18-7853-1 bracket 1 - 18-7924 metal bowl 2 - 18-4256 1/4" pipe plugs |
| 1/4" Stainless Steel w/ metal drain bowl | 18-7938 | 10 | 1 - 18-7919 filter & 1 18-7777 bracket 1 - 18-7924 metal bowl 2 - 18-4256 1/4" pipe plugs |

COMPACT BRACKET AND SEPARATOR KIT - FOR SMALL OUTBOARDS AND FRESH WATER APPLICATIONS



18-7774
COMPACT ALUMINUM BRACKET

18-7965-1
10 MICRON COMPACT
SEPARATOR KIT
Contains:
1 - 18-7774 bracket
1 - 18-7865 filter



REPLACEMENT FILTERS



UNIVERSAL DESIGN - DIRECT REPLACEMENT FOR MERCURY

| 10 MICRON REPLACEMENT FILTERS | | | 21 MICRON REPLACEMENT FILTERS | | |
|-------------------------------|--------------------|---------------------------------|-------------------------------|----------------|---------------------------------|
| Part # | Description | Replaces | Part # | Description | Replaces |
| 18-7944 | Short - 3.875" | Mercury - 35-807172, 35-802893Q | 18-7844 | Short - 3.875" | Mercury - 35-807172, 35-802893Q |
| 18-7945 | Long - 4.35" | Mercury - 35-802893Q | 18-7845 | Long - 4.35" | Mercury - 35-802893Q |
| 18-7866 | High Capacity - 6" | | | | |
| 18-7865 | Compact 10 Micron | | | | |



10 Micron replacement filters and kits with drain bowls

| REPLACEMENT FILTERS | | | REPLACEMENT BOWLS | |
|---------------------|---|----------------------------------|-------------------------------|--|
| Part # | Description | Replaces | Part # | Description |
| 18-7919 | Spin on replacement | 35-809097 Racor S3213 | 18-7924 | Metal Collection Bowl |
| 18-7920 | Spin on replacement | Mercury 35-809099 Racor S3214 | FILTER & BOWL KITS | |
| 18-7947 | Spin on replacement | Racor S3240 | Part # | Description |
| 18-7948 | Spin on replacement Fits - 320RRAC01 | 35-886638 Racor S3227 | 18-7929 | Filter & Metal Bowl Mercury Style Contains: 18-7919 filter, 18-7924 bowl |
| 18-7949 | Spin on replacement Fits - 660RRAC02 | Racor S3232 | 18-7943 | Filter & Metal Bowl Contains: 18-7920 filter, 18-7924 bowl |
| | | | 18-7969 | Filter & Metal bowl Contains: 18-7948 filter, 18-7924 bowl |



**18-7919
FUEL/WATER
SEPARATING FILTER**
Replaces: Mercruiser 35-809097
and Racor™ S3213
For styles with spin on drain bowls.



**18-7784
FUEL FILTER**
Replaces:
Mercruiser 35-11004A1, 35-803897Q1
For: 2.5L/3.0L(6229718 & later), All MC224 CID
(6218037 & later), All GM 262 CID (A331455 & later)
with Carter Fuel Pumps



**18-7977
"GEN III COOL FUEL
SYSTEM" FUEL FILTER**
Replaces: 35-866171A01
For: 350 Mag MPI Alpha/Bravo, 350 Mag MPI Horizon Alpha/
Bravo, 350 Mag MPI Horizon MIE, 350 Mag MPI MIE, 496
MAG, 496 MAG H.O., 5.0 MPI Alpha/Bravo, 8.1L Inboard, 8.1L
Inboard H.O., MX 6.2L MPI Alpha/Bravo, MX 6.2L MPI Horizon
Alpha/Bravo, MX 6.2L MPI Horizon MIE, MX 6.2L MPI MIE

I/O

MERCURISER

Fuel/Cooling Systems



18-7964
TRANSMISSION FILTER KIT

Replaces: 35-815419
For: Mercruiser V-8 Inboard with Hurth Transmission



18-7855
FUEL FILTER

Replaces: 1397-2150



18-7717
FILTER ELEMENT

Replaces: 35-93568
For: Rochester 2 bbl & 4 bbl Carburetors



18-7859
FUEL FILTER

Replaces: 35-53336,
3302-9033, 35-53336Q
For: Most GM Inline 4 & 6 cycle, Ford & Gm
V-8's up to 400 HP and all Mercruiser 224 CID



18-7721
FUEL FILTER

Replaces: 35-864572
All MPI & EFI engines with boost pump, 8.1L & 496cid,
for 3/8" ID fuel lines



18-7860
FUEL FILTER

Replaces: 35-49088A2, 35-49088Q2
(Used in 18-7278 Fuel Pump)
For: Inline 4 & 6 cycle engines



18-7869
FUEL FILTER

Replaces:
1397-8767, 1397-8545
For:

| Model/HP | Serial # | Model/HP | Serial # |
|--------------|-----------------|------------------|-----------------|
| GM 2.5L/3.0L | 6229718 & later | 330 HP | 6083145 & later |
| GM 5.0L/5.7L | 6218462 & later | GM 255 | 590768 & later |
| All 205 | A331455 & later | 5.7L SKI 340,230 | |
| 228 HP | 6021784 & later | & 260 Inboards | ALL |



18-7873
FUEL FILTER

Replaces: 35-808275
For: Models D7.3/270 Bravo & MIE Diesel
Engines 1994-96



18-6457
COMPOSITE PULLEY

Replaces: 807757T
3" OD Serpentine for 13/16" width belt,
For Late model GM V6 & V8 engines



18-3593
WATER PUMP

Replaces: 884727
Late Model 4 cyl GM engines requiring hose fitting



18-3574
CIRCULATING WATER PUMP

Big block GM engines with composite timing covers
"Late Model" includes 482 and 502 CID
Replaces: 850454, 8504541

| | | |
|---|---|---|
|  <p>18-3575 CIRCULATING WATER PUMP (Bi-Directional) Replaces: 65142A1 For: GM Inline (4 & 6 Cyl.)</p> |  <p>18-3577 CIRCULATING WATER PUMP (Bi-Directional) Replaces: 67859, 17670, 811573,8504541 For: Big block GM engines with stamped steel timing covers</p> |  <p>18-3573 CIRCULATING WATER PUMP All 8.1L big-block GM engines Replaces: 883925 For engines with composite timing cover</p> |
|  <p>18-3583 CIRCULATING WATER PUMP (Bi-Directional) Replaces: 60658, 8503991, 17437 For: GM V-6 & V-8 engines with stamped steel timing covers.</p> |  <p>18-3584 CIRCULATING WATER PUMP Replaces: Mercruiser 71683A1, 883885 Mercruiser 215 to 255 & 888 For: Ford small block V-8 engines.</p> |  <p>18-3599 CIRCULATING WATER PUMP Replaces: Mercruiser 811841, 850399, 8503991 For late model GM V-6 & V-8 engines using a composite timing cover</p> |
|  <p>18-3007 18-3007-10^① IMPELLER Replaces: 47-89983, 4789983T For 60 HP</p> |  <p>18-3016-1 IMPELLER KIT with gasket & plug Replaces: 47-862232A2 For: Late-model Bravo & High Performance. Includes 350 Mag., 4.3L., 496 Mag., 5.0L., 8.1S and MX 6.2L</p> |  <p>18-3017 18-3017-10^① IMPELLER Replaces: 47-89984, 47-89984T4, 47-30221, 47-65960 For all #1, R, MR, Alpha Units thru S/N D494568. Also for raw water pump on: 190 IB S/N 1564539-1720903 225 IB S/N 1539620-2278646</p> |
|  <p>18-3056 18-3056-10^① IMPELLER Replaces: 47-43026-2 For Alpha I-Generation 2 S/N D494569 & Above Mercruiser Vazer</p> |  <p>18-3087 IMPELLER Replaces: 47-59362, 47-59362T</p> |  <p>18-3109 WATER TUBE GUIDE Replaces: 23-29804, 23-29804T (used with 18-3116 Housing)</p> |

^① Discount shop pack of 10 - Priced per package

MERCUISER

Cooling System



| | | |
|--|---|---|
|  <p>18-3110 WATER PUMP HOUSING BUSHING Replaces: 26-38970 (Part of 18-3116 Housing)</p> |  <p>18-3114 INSERT CUP Replaces: 48752, 48752T (Part of 18-3116 Housing)</p> |  <p>18-3117 IMPELLER PLATE Replaces: 32435 For #1 Units thru S/N D494568</p> |
|  <p>18-3122 IMPELLER PLATE Replaces: 817276, 8172761 For Alpha I - Generation 2 S/N D494569 & Above</p> |  <p>18-3350 WEAR PLATE Replaces: 94576</p> |  <p>18-3351 WEAR PLATE Replaces: 94916</p> |
|  <p>18-3293 IMPELLER KEY Replaces: 28-43037</p> |  <p>18-3151 COUPLING Replaces: 816597</p> |  <p>18-3417 WATER PUMP BASE Replaces: 46-57234A1</p> |
|  <p>18-3420 WATER PUMP BASE Replaces: 46-44292A3</p> |  <p>18-3421 WATER PUMP BASE Replaces: 46-48748A1</p> |  <p>18-3116 WATER PUMP HOUSING Replaces: 46-96148A1</p> |
| <p>PKG. OF 2</p>  <p>18-2732 18-2732-9^① WATER SHUTTER Replaces: 807166A3</p> |  <p>18-2733 WATER SHUTTER Replaces: 99370A2</p> |  <p>18-2727 EXHAUST WATER SHUTTER Replaces: 60930</p> |

① Priced per Package

|  <p>18-3220 WATER TUBE Replaces: 32-54236 For #1 -R/MR/Alpha</p> |  <p>18-3221 WATER TUBE Replaces: 32-860220 For Gen II</p> |  <p>18-3222 WATER TUBE GUIDE Replaces: 23-816583 For Gen II</p> | | | | | | | | | | | | | | | | | | | | | | | | | | | | | | | | | |
|---|---|---|--|--------|-------|--------|------|---------|-----------------|------------------------|---|---------|-----------------|------------|---|---------|-----------------|-----------|---|---------|-----------|----------|---|---------|----------|------------------------|---|---------|----------------|--------|---|---------|--------|----------|---|
| <p>PKG. OF 5</p>  <p>18-3226 18-3226-9① IMPELLER PUMP SCREW Replaces: 10-30720 For R units</p> | <p>PKG. OF 5</p>  <p>18-3227 18-3227-9① WATER PUMP DOWEL PIN Replaces: 17-35973 For R/MR, Alpha I</p> | <p>PKG. OF 5</p>  <p>18-3229 18-3229-9① WATER POCKET SCREW Replaces: 10-28668 For MR/Alpha</p> |  <p>18-3197 SCREW Replaces: 10-76156</p> | | | | | | | | | | | | | | | | | | | | | | | | | | | | | | | | |
|  <p>18-3216 IMPELLER KIT Replaces: 47-59362A4 Fits: 1996-97 7.4L MIE MPI(LH) Gen VI GM 454 V8, 1996-97, 7.4L TBI MIE(LH) Gen VI GM 454 V8, 1996-97 8.2L MIE MPI(LH) Gen VI GM 502 V8.</p> | |  <p>18-3318 WATER PUMP KIT Replaces: 47-59362Q08 Fits: Plastic 1 and 2 piece sea water pump body</p> | | | | | | | | | | | | | | | | | | | | | | | | | | | | | | | | | |
| <div style="text-align: right;"> <p>② 18-3214D </p> </div> <div style="text-align: center;"> <p>18-3214 IMPELLER REPAIR KIT Replaces: 47-40326T6, T8, T11 For Alpha I - Generation II S/N D494569 & Above Mercruiser Vazer</p> <p>—CONTAINS—</p> <table border="1"> <thead> <tr> <th>Part #</th> <th>Desc.</th> <th>O.E. #</th> <th>Qty.</th> </tr> </thead> <tbody> <tr> <td>18-2564</td> <td>Impeller Gasket</td> <td>22-43033-1, 27-43033-1</td> <td>1</td> </tr> <tr> <td>18-2565</td> <td>Impeller Gasket</td> <td>27-43047-1</td> <td>1</td> </tr> <tr> <td>18-2566</td> <td>Impeller Gasket</td> <td>27-817277</td> <td>1</td> </tr> <tr> <td>18-2944</td> <td>Seal Ring</td> <td>12-19183</td> <td>1</td> </tr> <tr> <td>18-3056</td> <td>Impeller</td> <td>47-43026-1, 47-43026-2</td> <td>1</td> </tr> <tr> <td>18-3122</td> <td>Impeller Plate</td> <td>817276</td> <td>4</td> </tr> <tr> <td>18-7420</td> <td>O-Ring</td> <td>25-21836</td> <td>1</td> </tr> </tbody> </table>  </div> | | | | Part # | Desc. | O.E. # | Qty. | 18-2564 | Impeller Gasket | 22-43033-1, 27-43033-1 | 1 | 18-2565 | Impeller Gasket | 27-43047-1 | 1 | 18-2566 | Impeller Gasket | 27-817277 | 1 | 18-2944 | Seal Ring | 12-19183 | 1 | 18-3056 | Impeller | 47-43026-1, 47-43026-2 | 1 | 18-3122 | Impeller Plate | 817276 | 4 | 18-7420 | O-Ring | 25-21836 | 1 |
| Part # | Desc. | O.E. # | Qty. | | | | | | | | | | | | | | | | | | | | | | | | | | | | | | | | |
| 18-2564 | Impeller Gasket | 22-43033-1, 27-43033-1 | 1 | | | | | | | | | | | | | | | | | | | | | | | | | | | | | | | | |
| 18-2565 | Impeller Gasket | 27-43047-1 | 1 | | | | | | | | | | | | | | | | | | | | | | | | | | | | | | | | |
| 18-2566 | Impeller Gasket | 27-817277 | 1 | | | | | | | | | | | | | | | | | | | | | | | | | | | | | | | | |
| 18-2944 | Seal Ring | 12-19183 | 1 | | | | | | | | | | | | | | | | | | | | | | | | | | | | | | | | |
| 18-3056 | Impeller | 47-43026-1, 47-43026-2 | 1 | | | | | | | | | | | | | | | | | | | | | | | | | | | | | | | | |
| 18-3122 | Impeller Plate | 817276 | 4 | | | | | | | | | | | | | | | | | | | | | | | | | | | | | | | | |
| 18-7420 | O-Ring | 25-21836 | 1 | | | | | | | | | | | | | | | | | | | | | | | | | | | | | | | | |

① Priced per Package

② Items ending in "D" are Display Packaged - Regular number is Non-Display



MERCURISER

Cooling System



① 18-3217D



—CONTAINS —

| Part # | Desc. | O.E. # | Qty. |
|---------|--|------------|------|
| 18-3109 | Water Tube | 23-29804 | 1 |
| 18-3017 | Impeller | 47-89984 | 1 |
| 18-2919 | Water Pump Base to Gear Housing Gasket | 27-42631-1 | 1 |
| 18-3110 | Grommet | 26-38970 | 1 |
| 18-2945 | Gear Housing Drain Screw Gasket | 12-19183 | 2 |
| 18-2826 | Water Pump Base to Gear Housing Gasket | 27-85610-1 | 1 |
| 18-2914 | Lower Water Pump to Wear Plate Gasket | 27-85608-1 | 1 |
| 18-2915 | Upper Water Pump to Wear Plate Gasket | 27-85609-1 | 1 |
| 18-2944 | Seal Ring | 26-45577 | 1 |
| 18-3117 | Plate | 32435 | 1 |
| 18-7158 | O-Ring | 25-30613 | 1 |
| 18-7162 | O-Ring | 25-33145 | 1 |
| 18-7173 | O-Ring | 25-30224 | 1 |
| 18-7176 | O-Ring | 25-90011 | 1 |
| 18-2801 | Water Pump Gasket | 27-32438 | 1 |
| 18-7196 | O-Ring | 25-38099 | 1 |
| 18-7426 | O-Ring | 35-30271 | 1 |



**18-3217
IMPELLER KIT**

For #1 Units thru S/N D494568
(Similar to #46-96148A5 without base or housing)

**18-3237
IMPELLER REPAIR KIT**
For: Bravo I, II, III (1988 & up) B664190 & up Fits Bravo drives with 1 piece housing



—CONTAINS —

| Part # | Desc. | O.E. # | Qty. |
|---------|------------|----------|------|
| 18-3087 | Impeller | 47-59362 | 1 |
| 18-3350 | Wear Plate | 94576 | 1 |
| 18-7163 | O-Ring | 25-33465 | 1 |



**18-3224
WATER PUMP REPAIR KIT**

Replaces: 47-59362T6
For: Bravo (Plastic 1 piece body)

—CONTAINS —

| Part # | Desc. | O.E. # | Qty. |
|---------|------------|----------|------|
| 18-3087 | Impeller | 47-59362 | 1 |
| 18-3350 | Wear Plate | 94576 | 1 |



**18-3150
WATER PUMP KIT**
Replaces: 46-807151A14
For: Bravo

① 18-3309D



**18-3309
WATER PUMP KIT**
For: Bravo

—CONTAINS —

| Part # | Desc. | O.E. # | Qty. |
|---------|-------------------|-------------|------|
| 18-3350 | Wear Plate | 94576 | 1 |
| 18-3351 | Wear Plate | 94916 | 1 |
| 18-3087 | Impeller | 47-59362 | 1 |
| 18-0386 | Body Gasket | 27-94914 | 2 |
| 18-0916 | Water Pump Gasket | 27-805215-1 | 1 |



**18-3147
WATER PUMP KIT**
Replaces: 817275T4
For: Gen II-Lower
s/n D469859 and Up

—CONTAINS —

| Part # | Desc. | O.E. # | Qty. |
|---------|--|------------|------|
| 18-3109 | Water Tube | 23-29804 | 1 |
| 18-3017 | Impeller | 47-89984 | 1 |
| 18-3116 | Housing | 46-96148A1 | 1 |
| 18-2919 | Water Pump Base to Gear Housing Gasket | 27-42631-1 | 1 |
| 18-3417 | Water Pump Base | 46-57234A1 | 1 |
| 18-3110 | Grommet | 26-38970 | 1 |
| 18-2945 | Gear Housing Drain Screw Gasket | 12-19183 | 2 |
| 18-2826 | Water Pump Base to Gear Housing Gasket | 27-85610-1 | 1 |
| 18-2914 | Lower Water Pump to Wear Plate Gasket | 27-85608-1 | 1 |
| 18-2915 | Upper Water Pump to Wear Plate Gasket | 27-85609-1 | 1 |
| 18-2944 | Seal Ring | 26-45577 | 1 |
| 18-3117 | Plate | 32435 | 1 |
| 18-7158 | O-Ring | 25-30613 | 1 |
| 18-7162 | O-Ring | 25-33145 | 1 |
| 18-7173 | O-Ring | 25-30224 | 1 |
| 18-7176 | O-Ring | 25-90011 | 1 |
| 18-2801 | Water Pump Gasket | 27-32438 | 1 |
| 18-7196 | O-Ring | 25-38099 | 1 |
| 18-7426 | O-Ring | 35-30271 | 1 |
| 18-2919 | Water Pump Gasket | 27-46231-1 | 1 |



**18-3317
WATER PUMP KIT**
Replaces: 46-96148A8

① Items ending in "D" are Display Packaged - Regular number is Non-Display



**18-3320
WATER PUMP KIT**

| —CONTAINS — | | | |
|-------------|--|------------|------|
| Part # | Desc. | O.E. # | Qty. |
| 18-3109 | Water Tube | 23-29804 | 1 |
| 18-3017 | Impeller | 47-89984 | 1 |
| 18-3116 | Housing | 46-96148A1 | 1 |
| 18-3420 | Water Pump Base | 46-44292A3 | 1 |
| 18-2919 | Water Pump Base to Gear Housing Gasket | 27-42631-1 | 1 |
| 18-3110 | Grommet | 26-38970 | 1 |
| 18-2945 | Gear Housing Drain Screw Gasket | 12-19183 | 2 |
| 18-2826 | Water Pump Base to Gear Housing Gasket | 27-85610-1 | 1 |
| 18-2914 | Lower Water Pump to Wear Plate Gasket | 27-85608-1 | 1 |
| 18-2915 | Upper Water Pump to Wear Plate Gasket | 27-85609-1 | 1 |
| 18-2944 | Seal Ring | 26-45577 | 1 |
| 18-3117 | Plate | 32435 | 1 |
| 18-7158 | O-Ring | 25-30613 | 1 |
| 18-7162 | O-Ring | 25-33145 | 1 |
| 18-7173 | O-Ring | 25-30224 | 1 |
| 18-7176 | O-Ring | 25-90011 | 1 |
| 18-2801 | Water Pump Gasket | 27-32438 | 1 |
| 18-7196 | O-Ring | 25-38099 | 1 |
| 18-7426 | O-Ring | 35-30271 | 1 |



**18-3321
WATER PUMP KIT**

| —CONTAINS — | | | |
|-------------|--|------------|------|
| Part # | Desc. | O.E. # | Qty. |
| 18-3109 | Water Tube | 23-29804 | 1 |
| 18-3017 | Impeller | 47-89984 | 1 |
| 18-3116 | Housing | 46-96148A1 | 1 |
| 18-3421 | Water Pump Base | 46-48748A1 | 1 |
| 18-2919 | Water Pump Base to Gear Housing Gasket | 27-42631-1 | 1 |
| 18-3110 | Grommet | 26-38970 | 1 |
| 18-2945 | Gear Housing Drain Screw Gasket | 12-19183 | 2 |
| 18-2826 | Water Pump Base to Gear Housing Gasket | 27-85610-1 | 1 |
| 18-2914 | Lower Water Pump to Wear Plate Gasket | 27-85608-1 | 1 |
| 18-2915 | Upper Water Pump to Wear Plate Gasket | 27-85609-1 | 1 |
| 18-2944 | Seal Ring | 26-45577 | 1 |
| 18-3117 | Plate | 32435 | 1 |
| 18-7158 | O-Ring | 25-30613 | 1 |
| 18-7162 | O-Ring | 25-33145 | 1 |
| 18-7173 | O-Ring | 25-30224 | 1 |
| 18-7176 | O-Ring | 25-90011 | 1 |
| 18-2801 | Water Pump Gasket | 27-32438 | 1 |
| 18-7196 | O-Ring | 25-38099 | 1 |
| 18-7426 | O-Ring | 35-30271 | 1 |

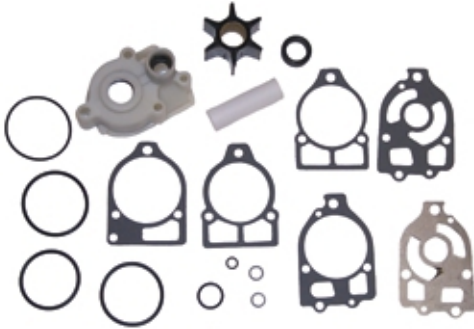

**18-3517
WATER PUMP KIT
Without Base**
Replaces: 46-96148A5,46-60367A1

| —CONTAINS — | | | |
|-------------|--|--------------------|------|
| Part # | Desc. | O.E. # | Qty. |
| 18-3109 | Water Tube | 23-29804 | 1 |
| 18-3017 | Impeller | 47-89984 | 1 |
| 18-3116 | Housing | 46-96148A1 | 1 |
| 18-2919 | Water Pump Base to Gear Housing Gasket | 27-42631-1 | 1 |
| 18-3110 | Grommet | 26-38970 | 1 |
| 18-2945 | Gear Housing Drain Screw Gasket | 26-20260, 12-19183 | 2 |
| 18-2826 | Water Pump Base to Gear Housing Gasket | 27-85610-1 | 1 |
| 18-2914 | Lower Water Pump to Wear Plate Gasket | 27-85608-1 | 1 |
| 18-2915 | Upper Water Pump to Wear Plate Gasket | 27-85609-1 | 1 |
| 18-2944 | Seal Ring | 26-45577 | 1 |
| 18-3117 | Plate | 32435 | 1 |
| 18-7158 | O-Ring | 25-30613 | 1 |
| 18-7162 | O-Ring | 25-33145 | 1 |
| 18-7173 | O-Ring | 25-30224 | 1 |
| 18-7176 | O-Ring | 25-90011 | 1 |
| 18-2801 | Water Pump Gasket | 27-32438 | 1 |
| 18-7196 | O-Ring | 25-38099 | 1 |
| 18-7426 | O-Ring | 35-30271 | 1 |

COMPLETE WATER PUMP KIT, IMPELLER REPAIR KIT, IMPELLER APPLICATION

| Model | Serial Number | Complete Water Pump Kit | Upper Pump Housing | Upper Pump Kit | Water Pump Base | Impeller Repair Kit | Impeller |
|---|-------------------|-------------------------|--------------------|----------------|----------------------|---------------------|----------|
| #1 Units with plastic flush screw in gear housing | 2495186-2763441 | 18-3321 | 18-3116 | 18-3517 | 18-3421 | 18-3217 | 18-3017 |
| #1 Units/R w/o flush screw in gear housing | 2763442-6854392 | 18-3317 ^① | 18-3116 | 18-3517 | 18-3417 ^① | 18-3217 | 18-3017 |
| MR/ALPHA I | 6854393 - D594568 | 18-3320 | 18-3116 | 18-3517 | 18-3420 | 18-3217 | 18-3017 |
| ALPHA I - Generation II | D494569 & ABOVE | — | 18-3147 | — | — | 18-3214 | 18-3056 |
| BRAVO/Inboards with externally mounted pump | 3040411 & ABOVE | — | — | — | — | — | 18-3087 |

^① Models which have been retro-fitted with an Alpha style lower unit (no pre-load pin in top of driveshaft) must use Alpha style parts (18-3320 and 18-3420)



GENERATION II WATER PUMP ASSEMBLY

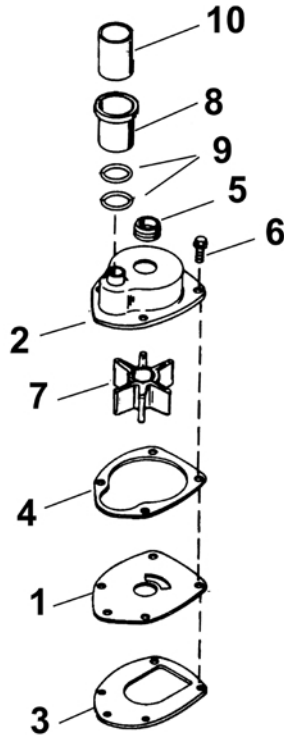

| Sequence | Description | Part # | O.E. # | Qty. |
|----------|------------------------|---------|-------------|------|
| 1. | Face Plate | 18-3122 | 817276 | 1 |
| 2. | Housing Assembly..... | N.S.S | — | 1 |
| 3. | Gasket, Base..... | 18-2564 | 27-43033-1 | 1 |
| 4. | Gasket, Housing..... | 18-2566 | 27-817277 | 1 |
| 5. | Seal, Face | 18-2599 | 26-816575A2 | 1 |
| 6. | Screw, Housing..... | N/A | — | 4 |
| 7. | Impeller..... | 18-3056 | 47-43026-2 | 1 |
| 8. | Coupling Assembly..... | 18-3151 | 47-43026T11 | 1 |
| 9. | O-Ring..... | 18-7420 | 25-21836 | 2 |
| 10. | Sleeve..... | N/A | — | 1 |

MR ALPHA WATER PUMP ASSEMBLY

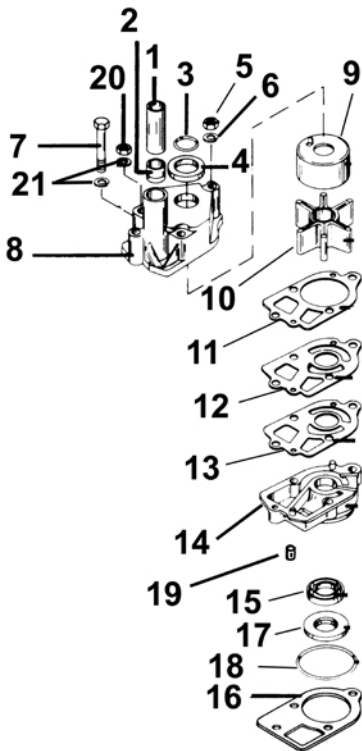

| Sequence | Description | Part # | O.E. # | Qty. |
|----------|--|---------|------------|------|
| 1. | Guide, Sleeve | 18-3109 | 23-29804 | 1 |
| 2. | Seal, Sleeve Guide (Included in 18-3109) | 18-3110 | 26-38970 | 1 |
| 3. | Ring, Upper | 18-7158 | 25-30613 | 1 |
| 4. | Ring, Dust..... | 18-7426 | 25-30271 | 1 |
| 5. | Nut, Housing..... | N/A | — | 1 |
| 6. | Washer, Housing | 18-4270 | 12-36001 | 3 |
| 7. | Screw, Housing..... | N/A | — | — |
| 8. | Housing, Water Pump..... | 18-3116 | 46-96148A1 | 1 |
| 9. | Cup, Impeller | — | — | — |
| 10. | Impeller..... | 18-3017 | 47-89984 | 1 |
| 11. | Gasket, Impeller | 18-2915 | 27-85609-1 | 1 |
| 12. | Plate, Impeller..... | 18-3117 | 32435 | 1 |
| 13. | Gasket, Stainless Steel Plate | 18-2914 | 27-85608-1 | 1 |
| 14. | Water Pump Base Assembly..... | 18-3420 | 46-44292A3 | 1 |
| 15. | Oil Seal, Water Pump Base (Included in 18-3420) | 18-2013 | 26-16977 | 1 |
| 16. | Gasket, Water Pump Base | 18-2919 | 27-42631-1 | 1 |
| 17. | Oil Seal, Water Pump Base (Included in 18-3420) | 18-2014 | 26-89238 | 1 |
| 18. | O-Ring, Water Pump Base | 18-7176 | 25-90011 | 1 |
| 19. | Pin, Alignment | N/A | — | — |
| 20. | Nut, Housing..... | N/A | — | — |
| 21. | Washer, Housing | 18-4275 | 12-29245 | 2 |

Courtesy of Seloc Publishing

R WATER PUMP ASSEMBLY

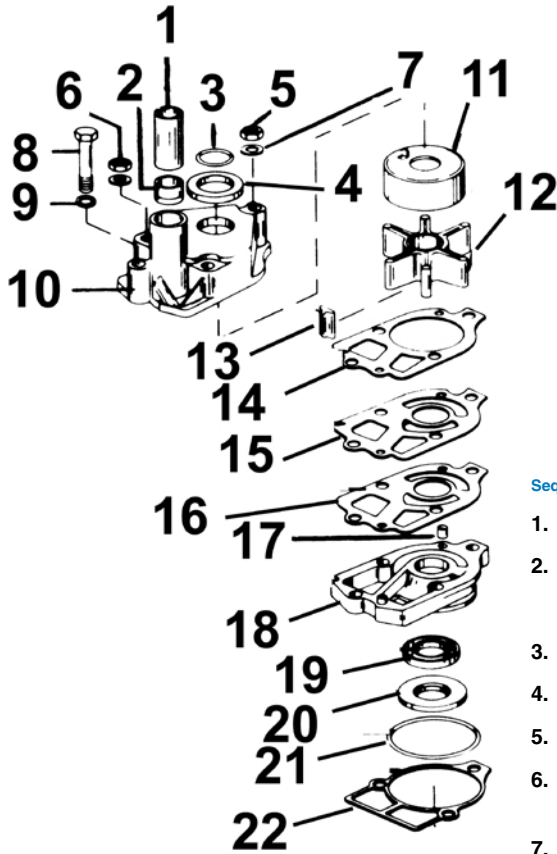

| Sequence | Description | Part # | O.E. # | Qty. |
|----------|---|---------|-----------------------|------|
| 1. | Guide, Water Tube | 18-3109 | 23-29804 | 1 |
| 2. | Grommet, Water Tube Guide (Included with 18-3109)..... | 18-3110 | 26-38970 | 1 |
| 3. | O-Ring | 18-7158 | 25-30613 | 1 |
| 4. | Seal, Dust Cover | 18-7426 | 25-30271 | 1 |
| 5. | Nut, Housing Retainer | 18-3723 | 11-45592 | 1 |
| 6. | Nut, Housing Retainer | 18-3722 | 11-20361, 11-35888 | 2 |
| 7. | Washer, Housing Retainer..... | 18-4275 | 12-29245 | 3 |
| 8. | Bolt, Housing Retainer | 18-3226 | 10-30720 | 1 |
| 9. | Washer, Housing Retainer..... | 18-4270 | 12-36001 | 1 |
| 10. | Housing, Impeller | 18-3116 | 46-96148A1 | 1 |
| 11. | Cup, Impeller (Included with 18-3116)..... | 18-3114 | 48752 | 1 |
| 12. | Impeller..... | 18-3017 | 47-89984 | 1 |
| 13. | Key, Impeller | N/A | — | — |
| 14. | Gasket, Impeller | 18-2915 | 27-85609-1 | 1 |
| 15. | Wear Plate, Impeller | 18-3117 | 32435 | 1 |
| 16. | Gasket, Wear Plate..... | 18-2914 | 27-85608-1 | 1 |
| 17. | Pin, Alignment | 18-3227 | 17-35973 | 1 |
| 18. | Base Assembly..... | 18-3417 | 46-57234A1 | 1 |
| 19. | Oil Seal, Base Assembly (Included in 18-3417) | 18-2013 | 26-16977 | 1 |
| 20. | Oil Seal, Base Assembly (Included in 18-3417) | 18-2014 | 26-89238 | 1 |
| 21. | O-Ring, Base Assembly | 18-7162 | 25-33145 | 1 |
| 22. | Gasket, Base Assembly | 18-2826 | 27-85610-1 | 1 |

Courtesy of Seloc Publishing



|  <p>18-3549 THERMOSTAT Replaces: 14586 120°</p> |  <p>18-3550 THERMOSTAT Replaces: 59078 140°</p> |  <p>18-3551 THERMOSTAT Replaces: 59137 142°</p> |  <p>18-3552 THERMOSTAT Replaces: 76270, 76270T 160°</p> |  <p>18-3555 THERMOSTAT Replaces: 99155A1 160°</p> | | | | | | | | | | | | | | | | | | | | | | | | | | | | | | | | | | | | | |
|--|--|--|--|---|-------------------|------------|-----------|---------------------------|----------------------|---|-------------------------|-----------------|-----------|-------------------------|-------------------------|-----------|-------------------------|--|---|-------------|-------------------------|----------|-----------------|-------------------------|------------|-------------------------|-------------------------|------------|--|-------------------------|-------------|---------|-------------------------|-------------------------|------------|---------|-------------------------|----------|---------------------------|----------------------|--|
|  <p>18-3557 THERMOSTAT Replaces: 47594 143°</p> |  <p>18-3649 THERMOSTAT Replaces: 807252-2 160°</p> |  <p>18-3568 THERMOSTAT KIT Replaces: 99155T1</p> <table border="1"> <thead> <tr> <th>Model</th> <th>Year</th> <th>Serial #</th> </tr> </thead> <tbody> <tr> <td>5.7MIE</td> <td>1998-2001</td> <td>OL002003 & Up</td> </tr> <tr> <td>MX6.2LMPI</td> <td>2000-2001</td> <td>OL680003 & Up</td> </tr> <tr> <td>454 Horizon MIE</td> <td>1998-2001</td> <td>OL002200 & Up</td> </tr> <tr> <td>502 Mag. MPI</td> <td>1998-2001</td> <td>OL017000 & Up</td> </tr> </tbody> </table> | Model | Year | Serial # | 5.7MIE | 1998-2001 | OL002003 & Up | MX6.2LMPI | 2000-2001 | OL680003 & Up | 454 Horizon MIE | 1998-2001 | OL002200 & Up | 502 Mag. MPI | 1998-2001 | OL017000 & Up |  <p>18-3644 THERMOSTAT KIT —CONTAINS—</p> <table border="1"> <thead> <tr> <th>Part #</th> <th>Description</th> <th>O.E.#</th> </tr> </thead> <tbody> <tr> <td>18-3649</td> <td>Thermostat 160°</td> <td>807252T2</td> </tr> <tr> <td>18-2553</td> <td>Thermostat Cover Gasket</td> <td>27-47510</td> </tr> <tr> <td>18-2917</td> <td>Thermostat Cover Gasket</td> <td>27-53045-1</td> </tr> </tbody> </table> | Part # | Description | O.E.# | 18-3649 | Thermostat 160° | 807252T2 | 18-2553 | Thermostat Cover Gasket | 27-47510 | 18-2917 | Thermostat Cover Gasket | 27-53045-1 | | | | | | | | | | | |
| Model | Year | Serial # | | | | | | | | | | | | | | | | | | | | | | | | | | | | | | | | | | | | | | | |
| 5.7MIE | 1998-2001 | OL002003 & Up | | | | | | | | | | | | | | | | | | | | | | | | | | | | | | | | | | | | | | | |
| MX6.2LMPI | 2000-2001 | OL680003 & Up | | | | | | | | | | | | | | | | | | | | | | | | | | | | | | | | | | | | | | | |
| 454 Horizon MIE | 1998-2001 | OL002200 & Up | | | | | | | | | | | | | | | | | | | | | | | | | | | | | | | | | | | | | | | |
| 502 Mag. MPI | 1998-2001 | OL017000 & Up | | | | | | | | | | | | | | | | | | | | | | | | | | | | | | | | | | | | | | | |
| Part # | Description | O.E.# | | | | | | | | | | | | | | | | | | | | | | | | | | | | | | | | | | | | | | | |
| 18-3649 | Thermostat 160° | 807252T2 | | | | | | | | | | | | | | | | | | | | | | | | | | | | | | | | | | | | | | | |
| 18-2553 | Thermostat Cover Gasket | 27-47510 | | | | | | | | | | | | | | | | | | | | | | | | | | | | | | | | | | | | | | | |
| 18-2917 | Thermostat Cover Gasket | 27-53045-1 | | | | | | | | | | | | | | | | | | | | | | | | | | | | | | | | | | | | | | | |
| <p>① 18-3646D </p>  <p>18-3646 THERMOSTAT KIT Replaces: 807252Q3 —CONTAINS—</p> <table border="1"> <thead> <tr> <th>Part #</th> <th>Description</th> <th>O.E.#</th> </tr> </thead> <tbody> <tr> <td>18-3551</td> <td>Thermostat</td> <td>59137</td> </tr> <tr> <td>18-2917</td> <td>Thermostat Housing Gasket</td> <td>27-53045-1, 27-33918</td> </tr> <tr> <td>18-2844</td> <td>Thermostat Cover Gasket</td> <td>27-48818-1</td> </tr> <tr> <td>18-2553</td> <td>Thermostat Cover Gasket</td> <td>27-47510</td> </tr> <tr> <td>18-2834</td> <td>Thermostat Cover Gasket</td> <td>27-60208</td> </tr> </tbody> </table> | Part # | Description | O.E.# | 18-3551 | Thermostat | 59137 | 18-2917 | Thermostat Housing Gasket | 27-53045-1, 27-33918 | 18-2844 | Thermostat Cover Gasket | 27-48818-1 | 18-2553 | Thermostat Cover Gasket | 27-47510 | 18-2834 | Thermostat Cover Gasket | 27-60208 | <p>① 18-3647D </p>  <p>18-3647 THERMOSTAT KIT Replaces: 807252Q5 —CONTAINS—</p> <table border="1"> <thead> <tr> <th>Part #</th> <th>Description</th> <th>O.E.#</th> </tr> </thead> <tbody> <tr> <td>18-3649</td> <td>Thermostat</td> <td>807252-2</td> </tr> <tr> <td>18-2844</td> <td>Thermostat Cover Gasket</td> <td>27-48818-1</td> </tr> <tr> <td>18-2552</td> <td>Thermostat Cover Gasket</td> <td>27-33179-2</td> </tr> <tr> <td>18-2553</td> <td>Thermostat Cover Gasket</td> <td>27-47510</td> </tr> <tr> <td>18-7173</td> <td>O-Ring</td> <td>25-30224</td> </tr> <tr> <td>18-2917</td> <td>Thermostat Housing Gasket</td> <td>27-53045-1, 27-33918</td> </tr> </tbody> </table> | Part # | Description | O.E.# | 18-3649 | Thermostat | 807252-2 | 18-2844 | Thermostat Cover Gasket | 27-48818-1 | 18-2552 | Thermostat Cover Gasket | 27-33179-2 | 18-2553 | Thermostat Cover Gasket | 27-47510 | 18-7173 | O-Ring | 25-30224 | 18-2917 | Thermostat Housing Gasket | 27-53045-1, 27-33918 | <p>① 18-3648D </p>  <p>18-3648 THERMOSTAT KIT 160°</p> |
| Part # | Description | O.E.# | | | | | | | | | | | | | | | | | | | | | | | | | | | | | | | | | | | | | | | |
| 18-3551 | Thermostat | 59137 | | | | | | | | | | | | | | | | | | | | | | | | | | | | | | | | | | | | | | | |
| 18-2917 | Thermostat Housing Gasket | 27-53045-1, 27-33918 | | | | | | | | | | | | | | | | | | | | | | | | | | | | | | | | | | | | | | | |
| 18-2844 | Thermostat Cover Gasket | 27-48818-1 | | | | | | | | | | | | | | | | | | | | | | | | | | | | | | | | | | | | | | | |
| 18-2553 | Thermostat Cover Gasket | 27-47510 | | | | | | | | | | | | | | | | | | | | | | | | | | | | | | | | | | | | | | | |
| 18-2834 | Thermostat Cover Gasket | 27-60208 | | | | | | | | | | | | | | | | | | | | | | | | | | | | | | | | | | | | | | | |
| Part # | Description | O.E.# | | | | | | | | | | | | | | | | | | | | | | | | | | | | | | | | | | | | | | | |
| 18-3649 | Thermostat | 807252-2 | | | | | | | | | | | | | | | | | | | | | | | | | | | | | | | | | | | | | | | |
| 18-2844 | Thermostat Cover Gasket | 27-48818-1 | | | | | | | | | | | | | | | | | | | | | | | | | | | | | | | | | | | | | | | |
| 18-2552 | Thermostat Cover Gasket | 27-33179-2 | | | | | | | | | | | | | | | | | | | | | | | | | | | | | | | | | | | | | | | |
| 18-2553 | Thermostat Cover Gasket | 27-47510 | | | | | | | | | | | | | | | | | | | | | | | | | | | | | | | | | | | | | | | |
| 18-7173 | O-Ring | 25-30224 | | | | | | | | | | | | | | | | | | | | | | | | | | | | | | | | | | | | | | | |
| 18-2917 | Thermostat Housing Gasket | 27-53045-1, 27-33918 | | | | | | | | | | | | | | | | | | | | | | | | | | | | | | | | | | | | | | | |
| <p>① 18-3650D </p>  <p>18-3650 THERMOSTAT KIT —CONTAINS—</p> <table border="1"> <thead> <tr> <th>Part #</th> <th>Description</th> <th>O.E.#</th> </tr> </thead> <tbody> <tr> <td>18-2831</td> <td>Thermostat Gasket</td> <td>27-47590-1</td> </tr> <tr> <td>18-3550</td> <td>Thermostat</td> <td>59078</td> </tr> </tbody> </table> | Part # | Description | O.E.# | 18-2831 | Thermostat Gasket | 27-47590-1 | 18-3550 | Thermostat | 59078 | <p>① 18-3651D </p>  <p>18-3651 THERMOSTAT KIT —CONTAINS—</p> <table border="1"> <thead> <tr> <th>Part #</th> <th>Description</th> <th>O.E.#</th> </tr> </thead> <tbody> <tr> <td>18-2554</td> <td>Thermostat Cover Gasket</td> <td>27-90556</td> </tr> <tr> <td>18-2553</td> <td>Thermostat Cover Gasket</td> <td>27-47510</td> </tr> <tr> <td>18-2834</td> <td>Thermostat Cover Gasket</td> <td>27-60208</td> </tr> <tr> <td>18-2844</td> <td>Thermostat Cover Gasket</td> <td>27-48818-1</td> </tr> <tr> <td>18-3551</td> <td>Thermostat</td> <td>59137</td> </tr> </tbody> </table> | Part # | Description | O.E.# | 18-2554 | Thermostat Cover Gasket | 27-90556 | 18-2553 | Thermostat Cover Gasket | 27-47510 | 18-2834 | Thermostat Cover Gasket | 27-60208 | 18-2844 | Thermostat Cover Gasket | 27-48818-1 | 18-3551 | Thermostat | 59137 |  <p>18-3652 THERMOSTAT KIT —CONTAINS—</p> <table border="1"> <thead> <tr> <th>Part #</th> <th>Description</th> <th>O.E.#</th> </tr> </thead> <tbody> <tr> <td>18-2555</td> <td>Thermostat Cover Gasket</td> <td>27-89656-1</td> </tr> <tr> <td>18-2843</td> <td>Thermostat Cover Gasket</td> <td>27-74830</td> </tr> <tr> <td>18-3552</td> <td>Thermostat</td> <td>76270</td> </tr> </tbody> </table> | Part # | Description | O.E.# | 18-2555 | Thermostat Cover Gasket | 27-89656-1 | 18-2843 | Thermostat Cover Gasket | 27-74830 | 18-3552 | Thermostat | 76270 |
| Part # | Description | O.E.# | | | | | | | | | | | | | | | | | | | | | | | | | | | | | | | | | | | | | | | |
| 18-2831 | Thermostat Gasket | 27-47590-1 | | | | | | | | | | | | | | | | | | | | | | | | | | | | | | | | | | | | | | | |
| 18-3550 | Thermostat | 59078 | | | | | | | | | | | | | | | | | | | | | | | | | | | | | | | | | | | | | | | |
| Part # | Description | O.E.# | | | | | | | | | | | | | | | | | | | | | | | | | | | | | | | | | | | | | | | |
| 18-2554 | Thermostat Cover Gasket | 27-90556 | | | | | | | | | | | | | | | | | | | | | | | | | | | | | | | | | | | | | | | |
| 18-2553 | Thermostat Cover Gasket | 27-47510 | | | | | | | | | | | | | | | | | | | | | | | | | | | | | | | | | | | | | | | |
| 18-2834 | Thermostat Cover Gasket | 27-60208 | | | | | | | | | | | | | | | | | | | | | | | | | | | | | | | | | | | | | | | |
| 18-2844 | Thermostat Cover Gasket | 27-48818-1 | | | | | | | | | | | | | | | | | | | | | | | | | | | | | | | | | | | | | | | |
| 18-3551 | Thermostat | 59137 | | | | | | | | | | | | | | | | | | | | | | | | | | | | | | | | | | | | | | | |
| Part # | Description | O.E.# | | | | | | | | | | | | | | | | | | | | | | | | | | | | | | | | | | | | | | | |
| 18-2555 | Thermostat Cover Gasket | 27-89656-1 | | | | | | | | | | | | | | | | | | | | | | | | | | | | | | | | | | | | | | | |
| 18-2843 | Thermostat Cover Gasket | 27-74830 | | | | | | | | | | | | | | | | | | | | | | | | | | | | | | | | | | | | | | | |
| 18-3552 | Thermostat | 76270 | | | | | | | | | | | | | | | | | | | | | | | | | | | | | | | | | | | | | | | |

THERMOSTAT APPLICATION BEGINS ON PAGE 631

① Items ending in "D" are Display Packaged - Regular number is Non-Display

|  <p>18-3667 THERMOSTAT KIT —CONTAINS—</p> <table border="1"> <thead> <tr> <th>Part #</th> <th>Description</th> <th>O.E.#</th> </tr> </thead> <tbody> <tr> <td>18-2555</td> <td>Thermostat Cover Gasket</td> <td>27-89656-1</td> </tr> <tr> <td>18-3555</td> <td>Thermostat</td> <td>99155A1</td> </tr> </tbody> </table> | Part # | Description | O.E.# | 18-2555 | Thermostat Cover Gasket | 27-89656-1 | 18-3555 | Thermostat | 99155A1 | <p>① 18-3668D </p>  <p>18-3668 THERMOSTAT KIT —CONTAINS—</p> <table border="1"> <thead> <tr> <th>Part #</th> <th>Description</th> <th>O.E.#</th> </tr> </thead> <tbody> <tr> <td>18-2552</td> <td>Thermostat Cover Gasket</td> <td>27-33179-2</td> </tr> <tr> <td>18-2553</td> <td>Thermostat Cover Gasket</td> <td>27-47510</td> </tr> <tr> <td>18-2554</td> <td>Thermostat Cover Gasket</td> <td>27-41812</td> </tr> <tr> <td>18-3551</td> <td>Thermostat</td> <td>59137</td> </tr> <tr> <td>18-7173</td> <td>O-Ring</td> <td>25-30224</td> </tr> </tbody> </table> | Part # | Description | O.E.# | 18-2552 | Thermostat Cover Gasket | 27-33179-2 | 18-2553 | Thermostat Cover Gasket | 27-47510 | 18-2554 | Thermostat Cover Gasket | 27-41812 | 18-3551 | Thermostat | 59137 | 18-7173 | O-Ring | 25-30224 |  <p>18-1977-1 THERMOSTAT HOUSING Replaces: 47441A1 Fits 225, GM 260, 228, 898/198, 185R, 898R, 228R, 2GR</p> |
|--|---|--|-------|---------|-------------------------|------------|---------|------------|---------|--|--------|-------------|-------|---------|-------------------------|------------|---------|-------------------------|----------|---------|-------------------------|----------|---------|------------|-------|---------|--------|----------|--|
| Part # | Description | O.E.# | | | | | | | | | | | | | | | | | | | | | | | | | | | |
| 18-2555 | Thermostat Cover Gasket | 27-89656-1 | | | | | | | | | | | | | | | | | | | | | | | | | | | |
| 18-3555 | Thermostat | 99155A1 | | | | | | | | | | | | | | | | | | | | | | | | | | | |
| Part # | Description | O.E.# | | | | | | | | | | | | | | | | | | | | | | | | | | | |
| 18-2552 | Thermostat Cover Gasket | 27-33179-2 | | | | | | | | | | | | | | | | | | | | | | | | | | | |
| 18-2553 | Thermostat Cover Gasket | 27-47510 | | | | | | | | | | | | | | | | | | | | | | | | | | | |
| 18-2554 | Thermostat Cover Gasket | 27-41812 | | | | | | | | | | | | | | | | | | | | | | | | | | | |
| 18-3551 | Thermostat | 59137 | | | | | | | | | | | | | | | | | | | | | | | | | | | |
| 18-7173 | O-Ring | 25-30224 | | | | | | | | | | | | | | | | | | | | | | | | | | | |
|  <p>18-1989 THERMOSTAT HOUSING Replaces: 87290A4, 861006A1 Stainless Steel Use 18-1989K Thermostat Service Kit for replacement parts</p> |  <p>18-1993 THERMOSTAT HOUSING Replaces: 78984A01, 861493A3</p> |  <p>18-1994 THERMOSTAT HOUSING Replaces: 87290A4 For: Stainless Steel Version use 18-1989</p> | | | | | | | | | | | | | | | | | | | | | | | | | | | |
|  <p>18-3530-1 THERMOSTAT HOUSING Replaces: 860256A4 For: GM V6 and V8 (305 & 350 ci)</p> |  <p>18-3678 THERMOSTAT HOUSING Replaces: 90736A18 For: GM 370, 425, 454 Mag & 465 V8</p> |  <p>18-3531 THERMOSTAT HOUSING Replaces: 861188A1 Fits: MCM/MIE GM V-6 & V-8 305,350,454 & 502 cid engines with closed cooling systems</p> | | | | | | | | | | | | | | | | | | | | | | | | | | | |
|  <p>18-3532 THERMOSTAT HOUSING AND COVER Replaces: 55131A5 Fits: MCM/MIE GM V6 & V8, 305, 350, 454, and 502cid, engines with closed cooling</p> |  <p>18-1910 THERMOSTAT HOUSING KIT Replaces: 861493A3 Fits: 3.0L GM 181 L/4 (1999-Up)</p> |  <p>18-1989K THERMOSTAT SERVICE KIT Service Kit for 18-1989 Thermostat Housing</p> | | | | | | | | | | | | | | | | | | | | | | | | | | | |

THERMOSTAT APPLICATION BEGINS ON NEXT PAGE

① Items ending in "D" are Display Packaged - Regular number is Non-Display

MERCUISER

Cooling System



THERMOSTAT APPLICATION

| Engine Model | Beg. S/N | End. S/N | Thermostat | Gaskets | Housing | Thermostat Kit |
|------------------------------|-----------|----------|------------|------------------|-----------|----------------|
| ROVER | 3140000 | UP | 18-3551 | — | — | — |
| 60 | 1887079 | 2049044 | 18-3551 | — | — | — |
| 80 | 2049045 | 2851423 | 18-3551 | — | — | — |
| 90 | 2851424 | 3226957 | 18-3557 | 18-2831 | — | — |
| 110 | 1537370 | 2044033 | 18-3551 | — | — | — |
| 120 | ① 1666601 | 3377340 | 18-3551 | — | — | — |
| 120 | ② 1725593 | 2324346 | 18-3551 | — | — | — |
| 120/2.5L | ② 2324347 | UP | 18-3550 | 18-2831 | — | 18-3650 |
| 140 (6 CYL) | 1538930 | 1725960 | 18-3551 | — | — | — |
| 140 (4 CYL)/3.0L | 2508261 | UP | 18-3550 | 18-2831 | — | 18-3650 ⑧ |
| 3.0L/3.0LX | C856559 | UP | 18-3550 | 18-2831 | — | 18-3650 |
| 150 | 1666495 | 2048046 | 18-3551 | — | — | — |
| 160 | ① 2048022 | 2770031 | 18-3551 | — | — | — |
| 160 | ② 2048022 | 2233574 | 18-3557 | — | — | — |
| 160 | ② 2326069 | 2770031 | 18-3557 | 18-2831 | — | — |
| 165 | 2770032 | 5813433 | 18-3550 | 18-2831 | — | 18-3650 |
| 165/3.7L (4 CYL) | 6916779 | UP | 18-3555 | 18-2555 | — | 18-3667 |
| 170 (4 CYL) | 6916779 | UP | 18-3555 | 18-2555 | — | 18-3667 |
| 175/4.3L, 4.3LX (262 CID) ③ | B527955 | UP | 18-3551 | 18-2553, 18-2554 | — | 18-3668 |
| 175/4.3L, 4.3 LX (262 CID) ④ | B527955 | UP | 18-3551 | 18-2552, 18-7173 | — | 18-3668 |
| 175/4.3L, 4.3 LX (262 CID) ④ | F001220 | UP | 18-3649 ⑦ | 18-2552, 18-7173 | — | 18-3648 |
| 180/3.7L-LX (4 CYL) | 6916779 | UP | 18-3555 | 18-2555 | — | 18-3667 |
| 185 (229 CID) | 6330183 | 6919655 | 18-3551 | 18-2553, 18-2554 | 18-1994 ⑨ | 18-3668 |
| 185 (262 CID) | A331455 | B527954 | 18-3551 | 18-2553, 18-2554 | 18-1994 ⑨ | 18-3668 |
| 190 | 1564539 | 1730903 | 18-3551 | — | — | — |
| 190 (4 CYL) | 6916779 | UP | 18-3555 | 18-2555 | — | 18-3667 |
| 200 | 2453769 | 2712072 | 18-3557 | 18-2831 | — | — |
| 200 GM | 6218462 | B525981 | 18-3551 | 18-2553, 18-2554 | 18-1994 ⑨ | 18-3668 |
| 200/5.0L | 0B525982 | 0F600999 | 18-3649 | 18-2917 | — | 18-3647 |
| 200/5.0L GM ③ | B525982 | UP | 18-3551 | 18-2553, 18-2554 | 18-1994 ⑨ | 18-3668 |
| 200/5.0L GM ④ | B525982 | UP | 18-3649 ⑦ | 18-2552, 18-7173 | 18-1994 ⑨ | 18-3648 |
| 205 (262 CID) | A331455 | B527954 | 18-3551 | 18-2553, 18-2554 | 18-1994 ⑨ | 18-3668 |
| 205/4.3L, 4.3LX (262 CID) ③ | B527955 | D714369 | 18-3551 | 18-2553, 18-2554 | 18-1994 ⑨ | 18-3668 |
| 205/4.3L, 4.3 LX (262 CID) ④ | B527955 | D714369 | 18-3551 | 18-2552, 18-7173 | — | 18-3668 |
| 205/4.3L, 4.3 LX (262 CID) ④ | F001220 | UP | 18-3649 ⑦ | 18-2552, 18-7173 | — | 18-3648 |
| 215 FORD | 2781153 | 3040410 | 18-3551 | — | — | — |
| 215 FORD | 3040411 | UP | 18-3551 | 18-2834 | — | 18-3651 |
| 215 FORD MCM/MIE | 3040411 | 3385720 | 18-3649 | 18-2834 | — | 18-3646 |
| 225 FORD MCM/MIE | 3385721 | 4176999 | 18-3649 | 18-2834 | — | 18-3646 |
| 225 GM | 1539620 | 2278646 | 18-3551 | — | — | — |
| 225 GM | 2278647 | 2399197 | 18-3551 | 18-2552, 18-7173 | — | 18-3668 |
| 225 GM | 2399198 | 2694014 | 18-3551 | 18-2553, 18-2844 | — | 18-3651 |
| 225/225S FORD | 3385721 | UP | 18-3551 | 18-2834 | — | 18-3651 |
| 228 GM MCM/MIE | 4765100 | 6218461 | 18-3649 | 18-2844, 18-2917 | — | 18-3646 |
| 228 GM | 4765100 | 6218461 | 18-3551 | 18-2844 | 18-1993 | 18-3651 |
| 228 GM | 6218462 | B525981 | 18-3551 | 18-2553, 18-2554 | 18-1994⑨ | 18-3668 |

- ① Aluminum Manifold
- ② Cast Iron
- ③ Old Design

- ④ New Design
- ⑤ Std. Cooling
- ⑥ Closed Cooling

- ⑦ 160°
- ⑧ S/N 6229718 & up
- ⑨ For stainless steel version use 18-1989