

# MERITOR® SLACK ADJUSTERS



**MERITOR®**



**PB-1533**

# TABLE OF CONTENTS

## **AUTOMATIC**

Automatic Slack Adjuster Miscellaneous Parts .....	9
Automatic Stroke-Sensing Slack Adjusters .....	4
Clearance-Sensing	
Cross Reference .....	10
Hardware .....	21
Premium Slacks .....	11
Service Brackets .....	26
Standard Slacks .....	20
Premium Self-Setting Self-Adjusting Automatic Slack Adjusters.....	18
Stroke-Sensing Repair Kits .....	8
Stroke-Sensing Service Parts .....	9

## **MANUAL**

Manual Slacks .....	24
Spec the Right Meritor Clevis for the Application .....	2

# SPEC THE RIGHT MERITOR CLEVIS FOR THE APPLICATION

Utilizing the correct Automatic Slack Adjuster (ASA) clevis is critical to maximizing brake life. The use of an incorrect clevis could result in an increase to operating costs.

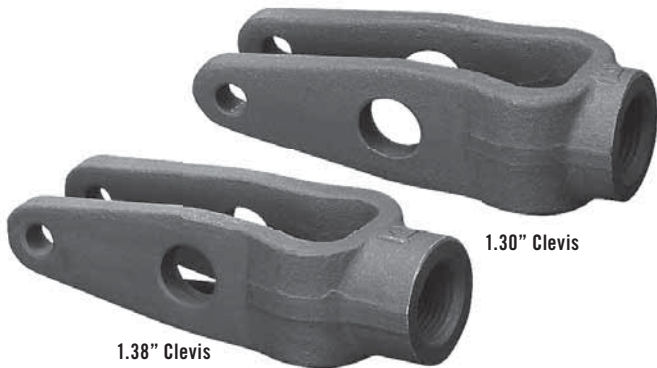

Meritor ASAs are sold in the aftermarket less clevis which allows the end user to properly spec the clevis for the intended application. Meritor manufactures clevises with pin spacings of 1.30" and 1.38" to accommodate a variety of applications. To maximize brake lining life, it is recommended to replace the clevis when the ASA is replaced.

When it's time to replace the ASA, replace the clevis following the Template Method as outlined here.

## Template Method for Replacing the ASA Clevis.

Measure the old clevis, or if the old clevis is not available, measure the clevis on the opposite wheel end of the axle by matching the two cutouts on the bottom of the template to the clevis holes.

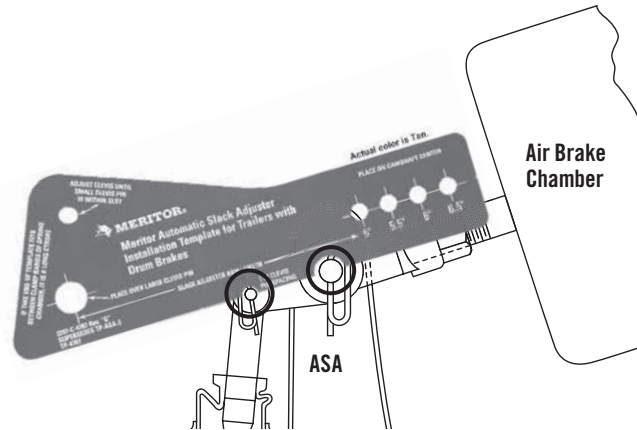

1. Use the correct Meritor ASA template to measure the length of the slack adjuster<sup>1</sup>. The marks by the holes in the small end of the template indicate the length of the slack adjuster.

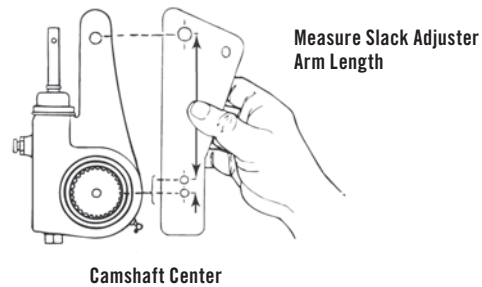

<sup>1</sup> The ASA templates are not interchangeable. The correct ASA template and clevis pin spacing must be used and the clevis position must be adjusted as described in the Template Method. If an incorrect combination is used and the clevis is installed in the wrong position, the slack adjuster will not adjust the brake correctly. If the slack adjuster under adjusts, stopping distances are increased. If the slack adjuster over adjusts, the linings may drag and damage the brake.



# SPEC THE RIGHT MERITOR CLEVIS FOR THE APPLICATION

(continued)



TP-4786 ASA template for trucks and tractors with drum brakes with 1.38" spacing!



TP-4787 ASA template for trailers with drum brakes. NOTE: Trailer must always use 1.38" spacing!



TP-10130 ASA template for trucks and tractors with drum brakes with 1.30" spacing!

2. Install the large clevis pin through the large holes in the ASA template and the clevis.
3. Select the hole in the ASA template that matches the length of the slack adjuster. Hold that hole on the center of the camshaft.

4. Look through the slot in the template to see if the small clevis hole completely aligns within the slot.

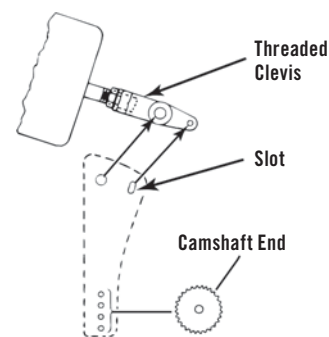

- If the small clevis hole doesn't align within the slot:

Adjust the clevis until you can see the small clevis pin hole within the slot (right).

5. Verify that the thread engagement between the clevis and push rod is 0.5" - 0.625" (12.7-15.9 mm).

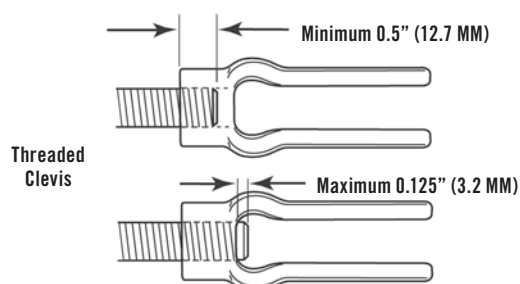

6. Verify that the push rod does not extend through the clevis more than 0.125" (3.2 mm).

- If the push rod extends through the clevis more than 0.125" (3.2 mm): Cut the push rod or install a new air chamber and push rod.

7. Tighten the jam nut against the clevis to the torque specification below.



Thread	Torque
1/2-20	20-30 lb-ft (27-41 N•m)
5/8-18	35-50 lb-ft (48-68 N•m)

**NOTE:** Use either the Template Method\* or BSAP Method\* to ensure the correct position of welded or threaded clevises on standard- or long-stroke brake chambers.

\* For more information on the Template or BSAP Methods, refer to Meritor Maintenance Manual 4, *Cam Brake and Automatic Slack Adjusters*. For information on welded-clevis air brake chambers, refer to the air brake chamber manufacturer's maintenance publication.

# AUTOMATIC STROKE-SENSING SLACK ADJUSTERS



TYPE A



TYPE B



UNHANDLED

CLEVIS PART NUMBER	UNCLEVIS PART NUMBER	CLEVIS KIT	TYPE	SPLINE DIA./NO. TEETH	LEVER LENGTH	CLEVIS TYPE	CLEVIS THREAD	USE WITH CHAMBER SIZE	REPLACES	COMMENTS
	R803000		A						A25-3275-X-1142	Black piston.
	R803001		B	1-1/4"-10	5"	Offset	1/2"-20	12, 9	A25-3275-Y-1143	Drum brake.
R802000	R803000	R810013LW	A	1-1/4"-10	5"	Straight	1/2"-20	12, 9	A25-3275-X-1142	Black piston.
R802001	R803001	R810014LW	B	1-1/4"-10	5"	Straight	1/2"-20	12, 9	A25-3275-Y-1143	Drum brake.
R802032	R803004	R810024	A	1-1/4"-10	5-1/2"	Offset	1/2"-20	16	A6-3275-Z-1144	Red piston.
R802033	R803005	R810024	B	1-1/4"-10	5-1/2"	Offset	1/2"-20	16	A6-3275-A-1145	Drum brake.
R802030	R803004	R810018	A	1-1/4"-10	5-1/2"	Straight	1/2"-20	16	A6-3275-Z-1144	Red piston.
R802031	R803005	R810018	B	1-1/4"-10	5-1/2"	Straight	1/2"-20	16	A6-3275-A-1145	Drum brake.
R801001	R803101	R810018	UNH	1-1/4"-10	5-1/2"	Straight	1/2"-20	16	A6-3275-H-1152	Red piston.
	R803002		A	1-1/4"-10	5-1/2"	Offset	1/2"-20	12, 9	A3-3275-Z-1144	Black piston.
R802023	R803003	R810016LW	B	1-1/4"-10	5-1/2"	Offset	1/2"-20	12, 9	A3-3275-A-1145	Drum brake.
	R803002		A	1-1/4"-10	5-1/2"	Straight	1/2"-20	12, 9	A3-3275-Z-1144	Black piston.
R802021	R803003	R810014LW	B	1-1/4"-10	5-1/2"	Straight	1/2"-20	12, 9	A3-3275-A-1145	Drum brake.
R802042	R803004	R810025	A	1-1/4"-10	5-1/2"	Offset	5/8"-18	20	A6-3275-Z-1144	Red piston.
R802048		R810025	A	1-1/4"-10	5-1/2"	Offset	5/8"-18	20		Drum brake.
R802043	R803005	R810025	B	1-1/4"-10	5-1/2"	Offset	5/8"-18	20	A6-3275-A-1145	Red piston.
R802040	R803004	R810019	A	1-1/4"-10	5-1/2"	Straight	5/8"-18	20	A6-3275-Z-1144	Drum brake.
R802041	R803005	R810019	B	1-1/4"-10	5-1/2"	Straight	5/8"-18	20	A6-3275-A-1145	Red piston.
R801004	R803101	R810019	UNH	1-1/4"-10	5-1/2"	Straight	5/8"-18	20	A6-3275-H-1152	Drum brake.
R802062	R803010	R810024	A	1-1/4"-24	5-1/2"	Offset	1/2"-20	16	A14-3275-Z-1144	Red piston.
R802063	R803011	R810024	B	1-1/4"-24	5-1/2"	Offset	1/2"-20	16	A14-3275-A-1145	Drum brake.
R802060	R803010	R810018	A	1-1/4"-24	5-1/2"	Straight	1/2"-20	16	A14-3275-Z-1144	Red piston.
R802061	R803011	R810018	B	1-1/4"-24	5-1/2"	Straight	1/2"-20	16	A14-3275-A-1145	Drum brake.
R801002	R803102	R810018	UNH	1-1/4"-24	5-1/2"	Straight	1/2"-20	16	A11-3275-H-1152	Red piston.
R802052	R803008	R810015LW	A	1-1/4"-24	5-1/2"	Offset	1/2"-20	12, 9	A11-3275-Z-1144	Black piston.
	R803009		B	1-1/4"-24	5-1/2"	Offset	1/2"-20	12, 9	A11-3275-A-1145	Drum brake.
	R803008		A	1-1/4"-24	5-1/2"	Straight	1/2"-20	12, 9	A11-3275-Z-1144	Black piston.
R802051	R803009	R810014LW	B	1-1/4"-24	5-1/2"	Straight	1/2"-20	12, 9	A11-3275-A-1145	Drum brake.
R801003	R803102	R810019	UNH	1-1/4"-24	5-1/2"	Straight	5/8"-18	16, 20	A11-3275-H-1152	Red piston.
R802072	R803010	R810025	A	1-1/4"-24	5-1/2"	Offset	5/8"-18	20	A14-3275-Z-1144	Drum brake.
R802073	R803011	R810025	B	1-1/4"-24	5-1/2"	Offset	5/8"-18	20	A14-3275-A-1145	Red piston.
R802656	R803070	R810025	A	1-1/4"-24	5-1/2"	Offset	5/8"-18	20	A4-3275-E-1201	Red piston. Drum brake. Special grease fitting location.
R802657	R803071	R810025	B	1-1/4"-24	5-1/2"	Offset	5/8"-18	20	A4-3275-F-1202	Red piston. Drum brake. Special grease fitting location.

# AUTOMATIC STROKE-SENSING SLACK ADJUSTERS

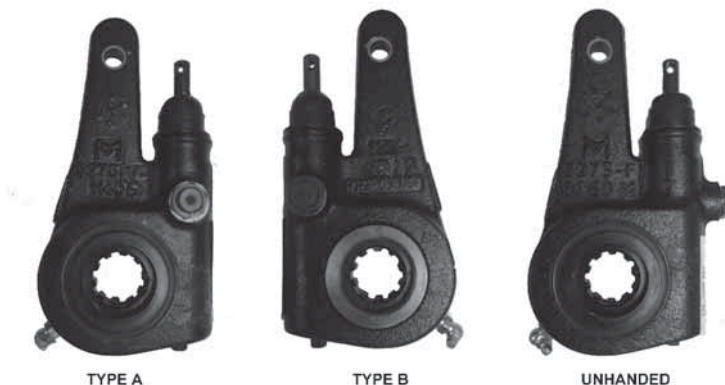

CLEVIS PART NUMBER	UNCLEVIS PART NUMBER	CLEVIS KIT	TYPE	SPLINE DIA./NO. TEETH	LEVER LENGTH	CLEVIS TYPE	CLEVIS THREAD	USE WITH CHAMBER SIZE	REPLACES	COMMENTS		
R802070	R803010	R810019	A	1-1/4"-24	5-1/2"	Straight	5/8"-18	20	A14-3275-Z-1144	Red piston.		
R802071	R803011	R810019	B						A14-3275-A-1145	Drum brake.		
R802074		R810019	A	1-1/4"-24	5-1/2"	Straight	5/8"-18	24	A75-3275-Z-1144	Yellow piston.		
R802075		R810019	B						A75-3275-A-1145	Drum brake.		
R802260	R803016	R810013LW	A			Straight			A26-3275-X-1142			
R802261		R810014LW	B						A26-3275-Y-1143			
	R803018		A			Straight	5/8"-18	36	A27-3275-X-1142	Green piston.		
R802281	R803019	R810019	B							A27-3275-Y-1143	Drum brake.	
R802300	R803022	R810018	A		5-1/2"	Straight	1/2"-20	16	A77-3275-Z-1144	Red piston.		
R802301	R803023	R810018	B								A77-3275-A-1145	Drum brake.
R802292	R803020	R810015LW	A		5-1/2"	Offset	1/2"-20	12, 9	A76-3275-Z-1144	Black piston.		
R802293	R803021	R810016LW	B								A76-3275-A-1145	Drum brake.
	R803020		A						Straight	1/2"-20	12, 9	A76-3275-Z-1144
	R803021		B				A76-3275-A-1145	Drum brake.				
R802310	R803022	R810019	A		5-1/2"	Straight	5/8"-18	20	A77-3275-Z-1144	Red piston.		
R802311	R803023	R810019	B								A77-3275-A-1145	Drum brake.
R802320	R803024	R810025	A		5-1/2"	Offset	5/8"-18	24, 30	A27-3275-Z-1144	Yellow piston.		
R802321	R803025	R810025	B								A27-3275-A-1145	Drum brake.
R802316	R803024	R810019	A		5-1/2"	Straight	5/8"-18	24, 30	A27-3275-Z-1144	Yellow piston. Drum brake.		
R802317	R803025	R810019	B									A27-3275-A-1145
R801041	R803195	R810019	UNH						A17-3275-H-1152			
R802644	R803026	R810019	A		5-1/2"	Straight	5/8"-18	24, 30	A18-3275-W-1193	Yellow piston. Drum brake.		
R802645	R803027	R810019	B								A18-3275-X-1194	Special grease fitting location.
	R803028		A		5-1/2"		5/8"-18	36	A78-3275-Z-1144	Green piston.		
R801043	R803104	R810019	UNH								A62-3275-H-1152	Drum brake.
R802667		R810019	B		5-1/2"		5/8"-18	36	A19-3275-X-1194	Green piston. Drum brake. Special grease fitting location.		
R801040	R803105	R810019	UNH		6"		5/8"-18	20, 24	A26-3275-J-1154	Red piston. Drum brake.		

# AUTOMATIC STROKE-SENSING SLACK ADJUSTERS

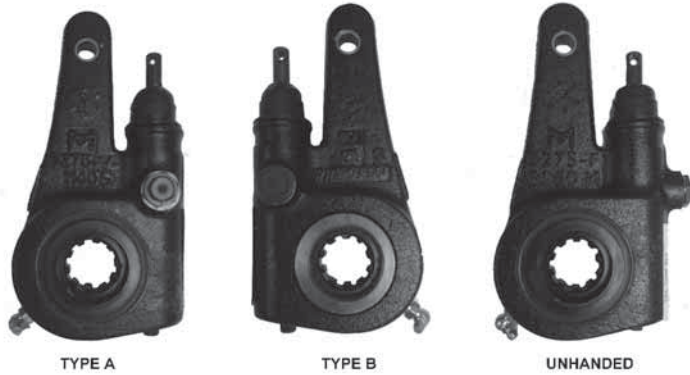

CLEVIS PART NUMBER	UNCLEVIS PART NUMBER	CLEVIS KIT	TYPE	SPLINE DIA./NO. TEETH	LEVER LENGTH	CLEVIS TYPE	CLEVIS THREAD	USE WITH CHAMBER SIZE	REPLACES	COMMENTS
R802354	R803030	R810019	A	1-1/2"-10	6"	Straight	5/8"-18	30	A4-3275-B-1146	Yellow piston.
R802355	R803031	R810019	B						A4-3275-C-1147	Drum brake.
R801042	R803106	R810019	UNH	1-1/2"-10	6"	Straight	5/8"-18	30	A5-3275-J-1154	Yellow piston. Drum brake. Trailer axle.
R802380	R803036	R810012	A	1-1/2"-10	7"	Straight	3/4"-16	30	A4-3275-N-1158	Red piston. Drum brake. Coach brake.
	R803037	B	A4-3275-P-1160							
R802402	R803038	R810015LW	A	1-1/2"-28	5"	Offset	1/2"-20	12, 9	A22-3275-X-1142	Black piston. Drum brake.
R802403		R810016LW	B						A22-3275-Y-1143	
R802400	R803038	R810013LW	A	1-1/2"-28	5"	Straight	1/2"-20	12, 9	A22-3275-X-1142	Black piston. Drum brake.
R802401		R810014LW	B						A22-3275-Y-1143	
R802412	R803040	R810019	A	1-1/2"-28	5"	Straight	5/8"-18	20, 24, 30	A14-3275-X-1142	Yellow piston. Drum brake.
R802414	R803040	R810019	A							
R802413	R803041	R810019	B							
R802415	R803041	R810019	B							
R802416	R803042	R810019	A	1-1/2"-28	5"	Straight	5/8"-18	36	A19-3275-X-1142	Green piston. Drum brake.
	R803043	B	A19-3275-Y-1143							
R802430	R803046	R810018	A	1-1/2"-28	5-1/2"	Straight	1/2"-20	16	A35-3275-Z-1144	Red piston. Drum and disc brakes.
R802431	R803047	R810018	B						A35-3275-A-1145	
R801070	R803108	R810018	UNH						A24-3275-H-1152	
R802422	R803044	R810015LW	A	1-1/2"-28	5-1/2"	Offset	1/2"-20	12, 9	A57-3275-Z-1144	Black piston. Drum and disc brakes.
R802423	R803045	R810016LW	B						A57-3275-A-1145	
R802421	R803044		A	1-1/2"-28	5-1/2"	Straight	1/2"-20	12, 9	A57-3275-Z-1144	Black piston. Drum and disc brakes.
	R803045	R810014LW	B						A57-3275-A-1145	

# AUTOMATIC STROKE-SENSING SLACK ADJUSTERS

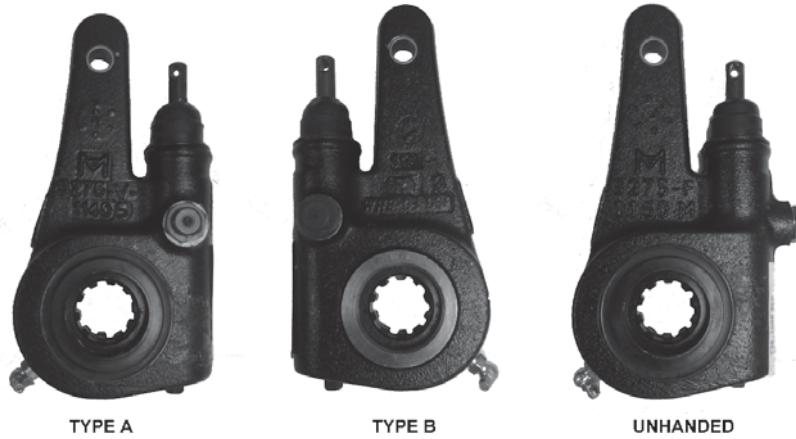

CLEVISED PART NUMBER	UNCLEVISED PART NUMBER	CLEVIS KIT	TYPE	SPLINE DIA./NO. TEETH	LEVER LENGTH	CLEVIS TYPE	CLEVIS THREAD	USE WITH CHAMBER SIZE	REPLACES	COMMENTS
R802444	R803052	R810019	A						A47-3275-Z-1144	
R802445	R803053	R810019	B	1-1/2"-28	5-1/2"	Straight	5/8"-18	20, 24, 36	A47-3275-A-1145	Green piston. Drum and disc brake.
R801072	R803109	R810019	UNH						A34-3275-H-1152, A48-3275-H-1152	
R802440	R803046	R810019	A	1-1/2"-28	5-1/2"	Straight	5/8"-18	20	A35-3275-Z-1144	Red piston. Drum and disc brake.
R802441	R803047	R810019	B						A35-3275-A-1145	
R801079	R803108	R810019	UNH	1-1/2"-28	5-1/2"			20	A24-3275-H-1152	Red piston. Drum brake.
R802446	R803048	R810019	A						A41-3275-Z-1144	
R802447	R803049	R810019	B	1-1/2"-28	5-1/2"	Straight	5/8"-18	24, 30	A41-3275-A-1145	Yellow piston. Drum brake.
R801073	R803110	R810019	UNH						A32-3275-H-1152	
R802463	R803050	R810019	A	1-1/2"-28	5-1/2"	Straight	5/8"-18	30	A44-3275-Z-1144	Blue piston. Disc brake.
R802462	R803051	R810019	B						A44-3275-A-1145	
R801071	R803111	R810019	UNH	1-1/2"-28	6"	Straight	5/8"-18	20, 24	A24-3275-J-1154	Red piston. Drum brake.
R802486	R803054	R810019	A						A14-3275-B-1146	
R802487	R803055	R810019	B	1-1/2"-28	6"	Straight	5/8"-18	30	A14-3275-C-1147	Yellow piston. Drum brake.
	R803112		UNH						A15-3275-J-1154	
R802490	R803056	R810019	A						A21-3275-B-1146	
R802491	R803057	R810019	B	1-1/2"-28	6"	Straight	5/8"-18	36	A21-3275-C-1147	Green piston. Drum brake.
	R803113		UNH						A18-3275-J-1154	
R802512	R803058	R810019	A	1-1/2"-28	6-1/2"	Straight	5/8"-18	36	A8-3275-D-1148	Green piston. Drum brake.
R802513	R803059	R810019	B						A8-3275-E-1149	
R802611		R810019	A						A79-3275-Z-1144	Yellow piston. Drum brake. Fruehauf.
R802610		R810019	B	1-5/8"-37	5-1/2"	Straight	5/8"-18	24, 30	A79-3275-A-1145	
R801101	R803114	R810019	UNH						A67-3275-H-1152	
	R803115		UNH	1-5/8"-37	6"	Straight	5/8"-18	20, 24	A27-3275-J-1154	Red piston. Drum brake. Trailer axle. Fruehauf.
R801102	R803116	R810019	UNH	1-5/8"-37	6"	Straight	5/8"-18	30	A28-3275-J-1154	Yellow piston. Drum brake. Fruehauf.
R802631	R803066	R810019	A						A13-3275-D-1148	Yellow piston. Drum brake. Fruehauf.
R802630		R810019	B	1-5/8"-37	6-1/2"	Straight	5/8"-18	30	A13-3275-E-1149	



# AUTOMATIC STROKE-SENSING SLACK ADJUSTERS REPAIR KIT

## R810005 CLEVIS PINS AND CLIPS

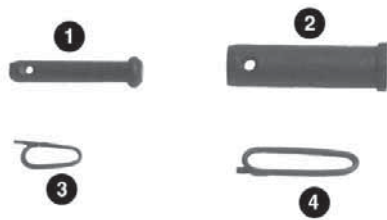

ITEM	QTY	PART NUMBER	DESCRIPTION	APPLICATION INFORMATION
1	1	19-X-127	Clevis Pin - Small	Clevis pins and clips. One kit contains enough parts to service one slack adjuster.
2	1	19-X-1084	Clevis Pin - Large	
3	1	2257-C-1173	Clip - Small	
4	1	2257-D-1174	Clip - Large	

## R810005LW CLEVIS PINS AND CLIPS FOR LIGHT WEIGHT CLEVIS

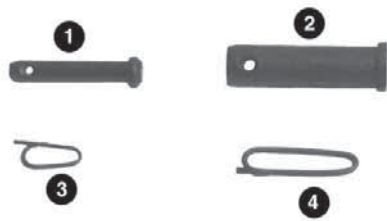

ITEM	QTY	PART NUMBER	DESCRIPTION	APPLICATION INFORMATION
1	1	19-X-127	Clevis Pin - Small	One kit contains enough parts to service one slack adjuster.
2	1	19-X-1116	Clevis Pin - Large	
3	1	2257-C-1173	Clip - Small	
4	1	2257-D-1174	Clip - Large	

# AUTOMATIC STROKE-SENSING SLACK ADJUSTERS SERVICE PARTS

## CLEVISES & CLEVIS KITS



	PART NUMBER	CLEVIS TYPE	PUSHROD	APPLICATION INFORMATION
	R810015LW	5/8" Offset	1/2"-20	1.38" C/C of pins. Clevis kit includes Lightweight Clevis, pins, clips and helper spring (2258-P-1238). For standard type 9, 12 and 16 chambers.
	R810016LW	5/8" Offset	1/2"-20	1.38" C/C of pins. Clevis kit includes Lightweight Clevis, pins, clips and helper spring (2258-Q-1239). For standard type 9, 12 and 16 chambers.
	R810022	5/8" Offset	1/2"-20	1.30" C/C of pins. Clevis kit includes Lightweight Clevis, pins and clips. For long stroke type 9, 12 and 16 chambers.
	R810024	5/8" Offset	1/2"-20	1.38" C/C of pins. Clevis kit includes Lightweight Clevis, pins and clips. For standard type 9, 12 and 16 chambers.
	R810013LW	Straight	1/2"-20	1.38" C/C of pins. Clevis kit includes Lightweight Clevis, pins, clips and helper spring (2258-P-1238). For standard type 9, 12 and 16 chambers.
	R810014LW	Straight	1/2"-20	1.38" C/C of pins. Clevis kit includes Lightweight Clevis, pins, clips and helper spring (2258-Q-1239). For standard type 9, 12 and 16 chambers.
	R810018	Straight	1/2"-20	1.38" C/C of pins. Clevis kit includes Lightweight Clevis, pins and clips. For standard type 9, 12 and 16 chambers.
	R810020	Straight	1/2"-20	1.30" C/C of pins. Clevis kit includes Lightweight Clevis, pins and clips. For long stroke type 9, 12 and 16 chambers.
	R810023	5/8" Offset	5/8"-18	1.38" C/C of pins. Clevis kit includes Lightweight Clevis, pins and clips. For long stroke type 20, 24, 30 and 36 chambers.
	R810025	5/8" Offset	5/8"-18	1.38" C/C of pins. Clevis kit includes Lightweight Clevis, pins and clips. For standard type 20, 24, 30 and 36 chambers.
	R810019	Straight	5/8"-18	1.38" C/C of pins. Clevis kit includes Lightweight Clevis, pins and clips. For standard type 20, 24, 30 and 36 chambers.
	R810021	Straight	5/8"-18	1.30" C/C of pins. Clevis kit includes Lightweight Clevis, pins and clips. For long stroke type 20, 24, 30 and 36 chambers.

## CLEARANCE-SENSING AUTOMATIC SLACK ADJUSTERS CROSS REFERENCE

Meritor Premium No.	Meritor Value No.	Haldex ABA Kit No.	Haldex ABA No.
M807000	R806000A		409-10129
M807001	R806001A	400-10402	409-10584
M807002	R806002A	400-10155	409-10635
M807003	R806003A	400-10156	409-10648
M807004	R806004A	400-10141	409-10650
M807005	R806005A	400-10304	409-10654
M807006	R806006A	400-10305	409-10655
M807007	R806007A	400-10306	409-10656
M807008	R806008A	400-10307	409-10657
M807009	R806009A	400-10001	409-10658
M807010	R806010A	400-10004	409-10659
M807011	R806011A	400-10005	409-10662
M807012	R806012A	400-10008	409-10663
M807013	R806013A	400-10212	409-10673
M807014	R806014A	400-10214	409-10674
M807015	R806015A	400-10216	409-10675
M807016	R806016A	400-10144	409-10678
M807017	R806017A	400-10146	409-10679
M807018	R806018A	400-10145	409-10680
M807019	R806019A	400-10211	409-10683
M807020	R806020A	400-10213	409-10684
M807021	R806021A	400-10215	409-10685
M807022	R806022A	400-10143	409-10733
M807023	R806023A	400-10142	409-10741
M807024	R806024A	400-10140	409-10742
M807025	R806025A	400-10008	409-10228
M807026	R806026A	400-10141	409-10653

# PREMIUM CLEARANCE-SENSING AUTOMATIC SLACK ADJUSTERS

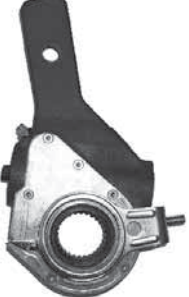
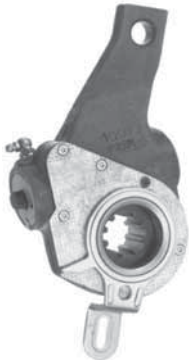
## STEERING AXLE (NON-DRIVE) APPLICATIONS FOR 15", 16-1/4" AND 16-1/2" BRAKES





	KIT NUMBER	INCLUDES BRACKET NO.	ANGLE	STRAIGHT/OFFSET	SPLINE SIZE	ARM LENGTH	BUSHING I.D.	APPLICATION
	M807009	R810302	0°	Straight	1-1/4"-10	5-1/2"	5/8"	Double Bend Control Arm. Standard Steering Axle Brakes. Replaces 400-10001, 409-10658
	M807010	R810303	0°	Straight	1-1/4"-24	5-1/2"	5/8"	Double Bend Control Arm. Standard Steering Axle Brakes. Replaces 400-10004, 409-10659
	M807011	R810302	0°	Straight	1-1/2"-10	5-1/2"	5/8"	Double Bend Control Arm. Standard Steering Axle Brakes. Replaces 400-10005, 409-10662
	M807012	R810302	0°	Straight	1-1/2"-28	5-1/2"	5/8"	Double Bend Control Arm. Standard Steering Axle Brakes. Replaces 400-10008, 409-10663
	M807025	R810300	16°	Straight	1-1/2"-28	5-1/2"	1/2"	Single Bend Control Arm. Standard Steering Axle Brakes.  Replaces 400-10081, 409-10228
	M807502	R810302	22°	LH 5/8"	1-1/4"-10	5-1/2"	5/8"	Double Bend Control Arm. For Standard Steering Axle Brakes with 5/8" Offset Arm. Replaces 400-10003, 409-10660
	M807503	R810302	22°	RH 5/8"	1-1/4"-10	5-1/2"	5/8"	Double Bend Control Arm. For Standard Steering Axle Brakes with 5/8" Offset Arm. Replaces 400-10002, 409-10661
	M807504	R810303	22°	LH 5/8"	1-1/4"-24	5-1/2"	5/8"	Double Bend Control Arm. For Standard Steering Axle Brakes with 5/8" Offset Arm. Replaces 400-10041, 409-10664
	M807505	R810303	22°	RH 5/8"	1-1/4"-24	5-1/2"	5/8"	Double Bend Control Arm. For Standard Steering Axle Brakes with 5/8" Offset Arm. Replaces 400-10040, 409-10665
	M807501	R810304	22°	RH 1-1/2"	1-1/2"-28	5-1/2"	1/2"	For Mack 16,000 lb.-Up Steering Axle Brakes with 1-1/2" Offset Arm. Replaces 400-10059, 409-10600
	M807500	R810304	22°	LH 1-1/2"	1-1/2"-28	5-1/2"	1/2"	For Mack 16,000 lb.-Up Steering Axle Brakes with 1-1/2" Offset Arm. Replaces 400-10058, 409-10599
	M807507	R810311	22°	LH 5/8"	1-1/2"-28	6"	1/2"	Single Bend Control Arm. Dina Bus - MCI Steer Axles Brakes. Replaces 400-10068, 409-10638
	M807508	R810314	22°	RH 5/8"	1-1/2"-28	6"	1/2"	Single Bend Control Arm. Dina Bus - MCI Steer Axles Brakes. Replaces 400-10069, 409-10639

**CAUTION:** Do not mix Automatic Slack Adjuster brands on the same vehicle.



# PREMIUM CLEARANCE-SENSING AUTOMATIC SLACK ADJUSTERS

## DRIVE AXLE APPLICATIONS FOR 16-1/2" AND 18" BRAKES

	KIT NUMBER	INCLUDES BRACKET NO.	ANGLE	STRAIGHT/OFFSET	SPLINE SIZE	ARM LENGTH	BUSHING I.D.	APPLICATION
	M807002	R810306	0°	Straight	1-1/2"-10	5-1/2"	5/8"	Kenworth with 8 Bag Air Ride to avoid interference with air bag supports. Replaces 400-10155, 409-10635
	M807003	R810306	0°	Straight	1-1/2"-28	5-1/2"	5/8"	Kenworth with 8 Bag Air Ride to avoid interference with air bag supports. Replaces 400-10156, 409-10648
	M807018	R810302	16°	Straight	1-1/2"-10	6"	1/2"	Double Bend Control Arm. For Mack Drive Axle Brakes. Replaces 400-10145, 409-10680
	M807016	R810302	16°	Straight	1-1/2"-28	6"	1/2"	Double Bend Control Arm. For Mack Drive Axle Brakes. Replaces 400-10144, 409-10678
	M807001	R810305	16°	Straight	1-1/2"-28	5-1/2"	1/2"	For Meritor Air Disc Brake. Replaces 400-10402, 409-10584
	M807017	R810302	16°	Straight	1-1/2"-28	5-1/2" - 6-1/2"	1/2"	Double Bend Control Arm. For Mack Drive Axle Brakes. Replaces 400-10146, 409-10679
	M807023	R810300	34°	Straight	1-1/2"-10	5" - 6"	5/8"	For Standard Drive Axle Brakes. Replaces 400-10142, 409-10741
	M807024	R810300	34°	Straight	1-1/2"-28	5" - 6"	5/8"	For Standard Drive Axle Brakes. Replaces 400-10140, 409-10742
	M807004	R810300	34°	Straight	1-1/2"	5-1/2"	5/8"	Single Bend Brake Control Arm. For Drive Axle Brakes. Replaces 400-10141, 409-10650
	M807022	R810300	34°	Straight	1-1/2"-10	5-1/2"	5/8"	For Standard Drive Axle Brakes. Replaces 400-10143, 409-10733
	M807026	R810300	34°	Straight	1-1/2"-28	5-1/2"	5/8"	For Standard Drive Axle Brakes. Replaces 400-10814, 409-1053

# PREMIUM CLEARANCE-SENSING AUTOMATIC SLACK ADJUSTERS

## TRAILER AXLE APPLICATIONS FOR 12-1/4" BRAKES

KIT NUMBER	INCLUDES BRACKET NO.	ANGLE	STRAIGHT/OFFSET	SPLINE SIZE	ARM LENGTH	BUSHING I.D.	APPLICATION
M807000	R810307	34°	Straight	1-1/2"-10	5"	1/2"	Single Bend Control Arm. For Delvan Trailer Axle Brake. Replaces 409-10129, 409-10655
M807007	R810301	35°	Straight	1-1/2"-10	6"	1/2"	Double Bend Control Arm. For Meritor, Eaton, Spicer (Dana) and Standard Forge with 4-Hole Cam Bracket. Improved, Longer Life Bushing and Flat Anchor Pin. Replaces 400-10306
M807006	R810301	35°	Straight	1-1/2"-28	6"	1/2"	Double Bend Control Arm. For Meritor, Eaton, Spicer (Dana) and Standard Forge with 4-Hole Cam Bracket. Improved, Longer Life Bushing and Flat Anchor Pin. Replaces 400-10305
M807005	R810301	35°	Straight	1-1/2"-28	5-1/2"	1/2"	Double Bend Control Arm. For Meritor, Eaton, Spicer (Dana) and Standard Forge with 4-Hole Cam Bracket. Improved, Longer Life Bushing and Flat Anchor Pin. Replaces 400-10304, 409-10654
M807008	R810301	35°	Straight	1-5/8"-37	6"	1/2"	Double Bend Control Arm. For Fruehauf with New Style 4-Hole Cam Bracket. Improved, Longer Life Bushing and Flat Anchor Pin. Replaces 400-10307, 409-10657



# PREMIUM CLEARANCE-SENSING AUTOMATIC SLACK ADJUSTERS





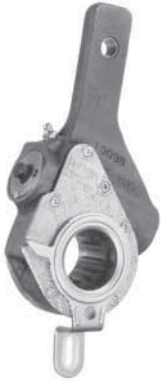

## TRAILER AXLE APPLICATIONS FOR 16-1/2" BRAKES

KIT NUMBER	INCLUDES BRACKET NO.	ANGLE	STRAIGHT/OFFSET	SPLINE SIZE	ARM LENGTH	BUSHING I.D.	APPLICATION
M807021	R810308	0°	Straight	1-1/2"-10	5-1/2"	1/2"	Double Bend Control Arm. For Meritor, Eaton, Standard Forge with 4-Hole Cam Bracket. Improved, Longer Life Bushing and Flat Anchor Pin. Replaces 400-10215, 409-10685
M807015	R810308	0°	Straight	1-1/2"-10	6"	1/2"	Double Bend Control Arm. For Meritor, Eaton, Standard Forge with 4-Hole Cam Bracket. Improved, Longer Life Bushing and Flat Anchor Pin. Replaces 400-10216, 409-10675
M807019	R810301	0°	Straight	1-1/2"-28	5-1/2"	1/2"	Double Bend Control Arm. For Meritor, Eaton, Standard Forge with 4-Hole Cam Bracket. Improved, Longer Life Bushing and Flat Anchor Pin. Replaces 400-10211, 409-10683
M807013	R810308	0°	Straight	1-1/2"-28	6"	1/2"	Double Bend Control Arm. For Meritor, Eaton, Standard Forge with 4-Hole Cam Bracket. Improved, Longer Life Bushing and Flat Anchor Pin. Replaces 400-10212, 409-10673
M807020	R810301	0°	Straight	1-5/8"-37	5-1/2"	1/2"	Double Bend Control Arm. For Fruehauf with New Style 4-Hole Cam Bracket. Improved, Longer Life Bushing and Flat Anchor Pin. Replaces 400-10213, 409-10684
M807014	R810301	0°	Straight	1-5/8"-37	6"	1/2"	Double Bend Control Arm. For Fruehauf with New Style 4-Hole Cam Bracket. Improved, Longer Life Bushing and Flat Anchor Pin. Replaces 400-10214, 409-10674



# PREMIUM CLEARANCE-SENSING AUTOMATIC SLACK ADJUSTERS



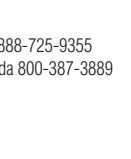



## TRANSIT APPLICATIONS

	KIT NUMBER	INCLUDES BRACKET NO.	ANGLE	STRAIGHT/OFFSET	SPLINE SIZE	ARM LENGTH	BUSHING I.D.	APPLICATION
	M807551		0°	Straight	1-1/2"28	5-1/2", 6-1/2"	6-1/4"	Single bend, 65mm. Replaces 4W9035
	M807556		0°	Straight	1-1/2"28	5-1/2"	1/2"	Double bend, 69mm. Replaces 4W9075, 300-10149
	M807549	R810312	0°	Straight	1-1/2"28	5-1/2"	1/2"	Single bend, 60mm. Includes bracket and hardware. Replaces 4W8525, 300-10052
	M807535	R810315	0°	Offset RH 1-1/2"	1-1/2"10	6"	1/2"	Includes bracket and hardware. Replaces 4W9055, 300-10185
	M807536	R810315	0°	Offset LH 1-1/2"	1-1/2"10	6"	1/2"	Includes bracket and hardware. Replaces 4W9060, 300-10187
	M807559	R810315	0°	Offset RH 1-1/2"	1-1/2"28	6"	1/2"	Includes bracket and hardware. Replaces 4W8715, 300-10186
	M807560	R810315	0°	Offset LH 1-1/2"	1-1/2"28	6"	1/2"	Includes bracket and hardware. Replaces 4W8720, 303-10188
	M807548	R810330	0°	Straight	1-1/2"28	5-1/2"	5/8"	Single bend, 65mm. Includes bracket and hardware. Replaces 4W9005,
	M807527	R810305	16°	Straight	1-1/2"10	5-1/2"	1/2"	Single bend, 64mm. Includes bracket and hardware. Replaces 4W8535, 30010042, 300-10011
	M807543	R810305	16°	Straight	1-1/2"28	5-1/2"	1/2"	Single bend, 64mm. Includes bracket and hardware. Replaces 4W8565, 300-10033







# PREMIUM CLEARANCE-SENSING AUTOMATIC SLACK ADJUSTERS

## TRANSIT APPLICATIONS

	KIT NUMBER	INCLUDES BRACKET NO.	ANGLE	STRAIGHT/OFFSET	SPLINE SIZE	ARM LENGTH	BUSHING I.D.	APPLICATION
	M807525	R810304	23°	Offset LH 1-1/2"	1-1/2"10	5-1/2"	1/2"	Single bend, 60mm. Includes bracket and hardware. Replaces 4W8540, 30010007
	M807526	R810304	23°	Offset LH 1-1/2"	1-1/2"10	5-1/2"	1/2"	Single bend, 60mm. Includes bracket and hardware. Replaces 4W8545, 30010008
	M807532	R810312	23°	Offset LH 5/8"	1-1/2"28	5-1/2"	1/2"	Single bend, 60mm. Includes bracket and hardware. Replaces 4W8510, 30010066
	M807533	R810312	23°	Offset RH 5/8"	1-1/2"28	5-1/2"	1/2"	Single bend, 60mm. Includes bracket and hardware. Replaces 4W8515, 30010067
	M807528	R810328	23°	Offset LH 5/8"	1-1/2"28	5-1/2"	1/2"	Single bend, 60mm. Includes bracket and hardware. Replaces 4W8620, 30010041
	M807529	R810328	23°	Offset RH 5/8"	1-1/2"28	5-1/2"	1/2"	Single bend, 60mm. Includes bracket and hardware. Replaces 4W8635, 30010042
	M807537		28°	Offset RH 1-9/16"	1-1/2"26	5-1/8"	1/2"	Double bend, 66mm. Replaces 4W3265
	M807538		28°	Offset LH 1-9/16"	1-1/2"26	5-1/8"	1/2"	Double bend, 66mm. Replaces 4W3270
	M807545		34°	Offset RH 1-1/2"	1-1/2"10	5-1/2"	1/2"	Single bend, 60mm. Replaces 4W8560, 30010035
	M807541		34°	Offset LH 1-1/2"	1-1/2"10	6"	1/2"	Single bend, 64mm. Replaces 4W8640, 30010025
	M807544		34°	Offset LH 1-1/2"	1-1/2"10	6"	1/2"	Replaces 4W9030
	M807552		34°	Straight	1-1/2"10	6"	1/2"	Single bend, 64mm. Replaces 4W9040
	M807554		34°	Offset LH 1-1/2"	1-1/2"10	7"	1/2"	Double bend, 69mm. Replaces 4W8590, 30010145
	M807555		34°	Offset RH 1-1/2"	1-1/2"10	7"	1/2"	Double bend, 69mm. Replaces 4W8680, 30010146

# PREMIUM CLEARANCE-SENSING AUTOMATIC SLACK ADJUSTERS

## TRANSIT APPLICATIONS

	KIT NUMBER	INCLUDES BRACKET NO.	ANGLE	STRAIGHT/OFFSET	SPLINE SIZE	ARM LENGTH	BUSHING I.D.	APPLICATION
	M807547	R810300	34°	Straight	1-1/2"28	6"	1/2"	Includes bracket and hardware. Replaces 4W9015
	M807521	R810309	34°	Offset LH 1-1/2"	1-1/2"10	7"	1/2"	Single bend, 64mm. Includes bracket and hardware. Replaces 4W8500, 3001009
	M807523	R810309	34°	Straight	1-1/2"10	7"	1/2"	Single bend, 64mm. Includes bracket and hardware. Replaces 4W8645, 30010003
	M807530	R810315	34°	Offset LH 1-1/2"	1-1/2"10	6"	1/2"	Single bend, 64mm. Includes bracket and hardware. Replaces 4W8600, 30010043
	M807534	R810312	34°	Straight	1-1/2"28	6-1/2"	1/2"	Single bend, 60mm. Includes bracket and hardware. Replaces 4W8520, 30010068
	M807531	R810315	34°	Offset RH 1-1/2"	1-1/2"10	6"	1/2"	Single bend, 64mm. Includes bracket and hardware. Replaces 4W8570, 30010044
	M807539	R810316	34°	Offset LH 1-1/2"	1-1/2"10	7"	1/2"	Single bend, 60mm. Includes bracket and hardware. Replaces 4W8615, 30010020
	M807540	R810316	34°	Offset RH 1-1/2"	1-1/2"10	7"	1/2"	Single bend, 60mm. Includes bracket and hardware. Replaces 4W8630, 30010021
	M807542	R810328	34°	Offset RH 1-1/2"	1-1/2"10	6"	1/2"	Single bend, 64mm. Includes bracket and hardware. Replaces 4W8605, 30010026
	M807546	R810328	34°	Offset LH 1-1/2"	1-1/2"28	5-1/2"	1/2"	Includes bracket and hardware. Replaces 4W9010
	M807550	R810329	34°	Straight	1-1/2"28	6-1/2"	1/2"	Single bend, 64mm. Includes bracket and hardware. Replaces 4W8690, 30010053
	M807553	R810331	34°	Straight	1-1/2"10	5-1/2"	5/8"	Includes bracket and hardware. Replaces 4W9050
	M807557	R810333	34°	Offset LH 1-1/2"	1-1/2"10	6"	1/2"	Single bend, 65mm. Includes bracket and hardware. Replaces 4W8625, 30010174
	M807558	R810333	34°	Offset RH 1-1/2"	1-1/2"10	6"	1/2"	Single bend, 65mm. Includes bracket and hardware. Replaces 4W8595, 30010175
	M807522	R810336	34°	Offset RH 1-1/2"	1-1/2"10	7"	1/2"	Single bend, 64mm. Includes bracket and hardware. Replaces 4W8650, 30010002
	M807524	R810336	34°	Straight	1-1/2"10	7"	1/2"	Single bend, 64mm. Includes bracket and hardware. Replaces 4W8610, 30010004
	M807563		120°	Offset RH 5/8"	1-1/2"26	5-1/8"	1/2"	Double bend, 65mm. Replaces 4W3115
	M807564		120°	Offset LH 5/8"	1-1/2"26	5-1/8"	1/2"	Double bend, 65mm. Replaces 4W3120

# PREMIUM SELF-SETTING SELF-ADJUSTING BRAKE ADJUSTERS

## DRIVE AXLE



KIT NUMBER	INCLUDES BRACKET NO.	ANGLE	STRAIGHT/OFFSET	SPLINE SIZE	ARM LENGTH	BUSHING I.D.	APPLICATION
M808004				1-1/2" 10	5-1/2"	1/2"	For Drive axle application with strap bracket. Replaces 400,-20238, 409-20044, uses hardware bracket 427-10554
M808007				1-1/2" - 10	6"	1/2"	For drive axle applications using plate and flat stud hardware. Replaces 400-20217, 409-20020 and hardware 427-10566
M808022	R810300			1-1/2" - 10	5-1/2"	5/8"	Standard Drive Axle. Anchor Bracket Strap Style. Replaces 400-20239, 409-20045
M808023	R810300			1-1/2" - 10	6"	5/8"	Standard Drive Axle. Anchor Bracket Strap Style. Replaces 400-20233, 409-20021
M808005				1-1/2" 28	5-1/2"	5/8"	For Drive axle application with strap bracket. Replaces 400,-20240, 409-20046, uses hardware bracket 427-10553
M808024	R810300			1-1/2" - 28	6"	5/8"	Standard Drive Axle. Anchor Bracket Strap Style. Replaces 400-20250, 409-20050

## STEERING AXLE



KIT NUMBER	INCLUDES BRACKET NO.	ANGLE	STRAIGHT/OFFSET	SPLINE SIZE	ARM LENGTH	BUSHING I.D.	APPLICATION
M808002				1-1/4" 10	5-1/2"	1/2"	For steering axle. Replaces 400-20229, 409-20018 uses hardware 427-10566
M808003				1-1/2" 10	5-1/2"	1/2"	For steering axle. Replaces 400-20236, 409-20009 uses hardware 427-10576
M808012	R810302			1-1/2" - 28	5-1/2"	1/2"	For Steering Axle. Replaces 400-20229, 409-20018

# PREMIUM SELF-SETTING SELF-ADJUSTING BRAKE ADJUSTERS

## TRAILER AXLE

KIT NUMBER	INCLUDES BRACKET NO.	ANGLE	STRAIGHT/OFFSET	SPLINE SIZE	ARM LENGTH	BUSHING I.D.	APPLICATION
M808006				1-1/2" 28	6"	1/2"	For Trailer axle applications using clamp style hardware brackets. Replaces 400-20243, 40920006 and uses hardware 427-10566
M808021	R810302	0°	Straight	1-1/2" - 10	5-1/2"	1/2"	Double Bend Control Arm. For Meritor, Eaton, Standard Forge with 4-Hole Cam Bracket. Improved , Longer Life Bushing And Flat Anchor Pin. Replaces 400-20215
M808015	R810302	0°	Straight	1-1/2" - 10	6"	1/2"	Double Bend Control Arm. For Meritor, Eaton, Standard Forge with 4-Hole Cam Bracket. Improved , Longer Life Bushing And Flat Anchor Pin. Replaces 400-20216
M808019	R810302	0°	Straight	1-1/2" - 28	5-1/2"	1/2"	Double Bend Control Arm. For Meritor, Eaton, Standard Forge with 4-Hole Cam Bracket. Improved , Longer Life Bushing And Flat Anchor Pin. Replaces 400-20211
M808013	R810302	0°	Straight	1-1/2" - 28	6"	1/2"	Double Bend Control Arm. For Meritor, Eaton, Standard Forge with 4-Hole Cam Bracket. Improved , Longer Life Bushing And Flat Anchor Pin. Replaces 400-20212
M808000				1-5/8" - 37	5-1/2"	1/2"	Double bend control arm. For Fruehauf with 4-hole cam bracket. Improved , longer life bushing and flat anchor pin. Replaces 400-20213, 409-20024 uses hardware kit 427-10563
M808001				1-5/8" - 37	6"	1/2"	Double bend control arm. For Fruehauf with 4-hole cam bracket. Improved , longer life bushing and flat anchor pin. Replaces 400-20214, 409-20025 uses hardware kit 427-10563















# STANDARD CLEARANCE-SENSING SLACK ADJUSTERS

## DRIVE AXLE APPLICATIONS FOR 16-1/2" AND 18" BRAKES

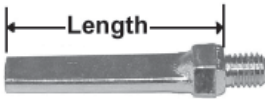
MERITOR KIT NO.	INCLUDES BRACKET NO.	ANGLE	STRAIGHT/OFFSET	SPLINE SIZE	ARM LENGTH	BUSHING I.D.	APPLICATION
R806002A	R810306	0°	Straight	1-1/2"10	5-1/2"	5/8"	Single Bend Control Arm. For Kenworth with 8 bag air ride to avoid interference with air bag supports. Replaces 400-10155, 409-10635
R806003A	R810306	0°	Straight	1-1/2"28	5-1/2"	5/8"	Single Bend Control Arm. For Kenworth with 8 bag air ride to avoid interference with air bag supports. Replaces 400-10156, 409-10648
R806018A	R810302	16°	Straight	1-1/2"10	6"	1/2"	Double Bend Control Arm. For Mack drive axle brakes. Replaces 400-10145, 409-10680
R806017A	R810302	16°	Straight	1-1/2"28	5-1/2", 6-1/2"	1/2"	Double Bend Control Arm. For Mack drive axle brakes. Replaces 400-10146, 409-10679
R806016A	R810302	16°	Straight	1-1/2"28	6"	1/2"	Double Bend Control Arm. For Mack drive axle brakes. Replaces 400-10144, 409-10678
R806001A	R810305	16°	Straight	1-1/2"28	5-1/2"	1/2"	Single Bend Control Arm. For Meritor air disc brakes. Replaces 400-10402, 409-10584
R806023A	R810300	34°	Straight	1-1/2"10	5", 6"	5/8"	Single Bend Control Arm. For standard drive axle brakes. Replaces 400-10142, 409-10741
R806022A	R810300	34°	Straight	1-1/2"10	5-1/2", 6-1/2"	5/8"	Single Bend Control Arm. For standard drive axle brakes. Replaces 400-10143, 409-10733
R806024A	R810300	34°	Straight	1-1/2"28	5", 6"	5/8"	Single Bend Control Arm. For standard drive axle brakes. Replaces 400-10140, 409-10742
R806004A	R810300	34°	Straight	1-1/2"28	5-1/2"	5/8"	Single Bend Control Arm. For standard drive axle brakes. Replaces 400-10141, 409-10650
R806026A	R810300	34°	Straight	1-1/2"28	5-1/2", 6-1/2"	5/8"	Single Bend Control Arm. For standard drive axle brakes. Replaces 400-10141, 409-10653









# CLEARANCE-SENSING AUTOMATIC SLACK ADJUSTERS

## HARDWARE

	PART NO.	DESCRIPTION	REPLACES	NOTES
	R810317	Anchor Screw	443-10188	Length 1-1/4", 7/16"-14 thread. Use with R810324 slide nut.
	R810321	Anchor Screw	443-10096	Length 1", 7/16"-14 thread.
	R810319	Bracket		Length 3.5", Width 2.375", .171" Thickness
	R810322	Bushing	452-10058	1/2" I.D. x 5/8" O.D.
	R810323	Bushing	452-10128	Serrated. 5/8" I.D. x 13/16" O.D.
	R810325	Double Flat Stud	443-10299	3" length.
	R810326	Double Flat Stud	443-10290	2-3/4" length.
	R810316	Fitting Kit		
	R810320	Flange Nut	443-10204	7/16"-14 thread.
	R810318	Grommet	452-10125	1-9/32" length x 11/16" width.
	R810327	Service Kit	427-10558	Includes 4 cap nuts, 4 anchor pins, 4 bushings. Services 4 ASA's.
	R810324	Slide Nut	443-10101	7/16"-14 thread.









# CLEARANCE-SENSING AUTOMATIC SLACK ADJUSTERS

## SERVICE BRACKET KITS

	PART NO.	APPLICATION	BRACKET STYLE	REPLACES	NOTES
	R810311	Drive Axle	Clamp	427-10421	2-1/4" - 2-1/2" tube clamp.
	R810314	Drive Axle	Clamp	427-10420	2-1/4" - 2-1/2" tube clamp.
	R810302	Drive and Steer Axle	Clamp	427-10566K	2-1/4" clamp. For use with Mack 16,000 lb.+ brakes.
	R810303	Steer Axle	Clamp	427-10567K	2" u-bolt clamp.
	R810310	Steer Axle	Clamp	427-10497	2-1/4" clamp. For use with 5/8" offset asa's.
	R810301	Trailer Axle	Plate and Stud	427-10563	Bracket Kit
	R810307	Trailer Axle	Plate and Stud		Bracket Kit
	R810308	Trailer Axle	Plate and Stud	427-10565	Cam support bracket with control arm bushing.

# CLEARANCE-SENSING AUTOMATIC SLACK ADJUSTERS

## SERVICE BRACKET KITS

	PART NO.	APPLICATION	BRACKET STYLE	REPLACES	NOTES
	R810304	Steer Axle, Transit	Spider	427-10548	3-3/4" bracket. For use with Mack 16,000 lb.+ steer axle brakes with 1-1/2" offset. Also used on Transit applications.
	R810313		Strap	427-10582	
	R810305	Drive and Steer Axle, Transit	Strap	427-10543	1-1/4" x 6-1/2" strap. For use with Meritor air disc brakes.
	R810306	Drive Axle	Strap	427-10554	1-1/4" x 4-3/4" strap. For use with Kenworth 8 air bag drive axle brakes.
	R810300	Drive Axle, Transit	Strap	427-10553K	Angled 1-1/4" x 7" strap
	R810309	Transit	Strap	427-10579	1-3/4" x 4-1/2" strap
	R810315	Transit	Strap	427-10517	1-1/4" x 5-1/2" strap.
	R810312	Transit	Stud	427-10517	

# MANUAL SLACK ADJUSTERS

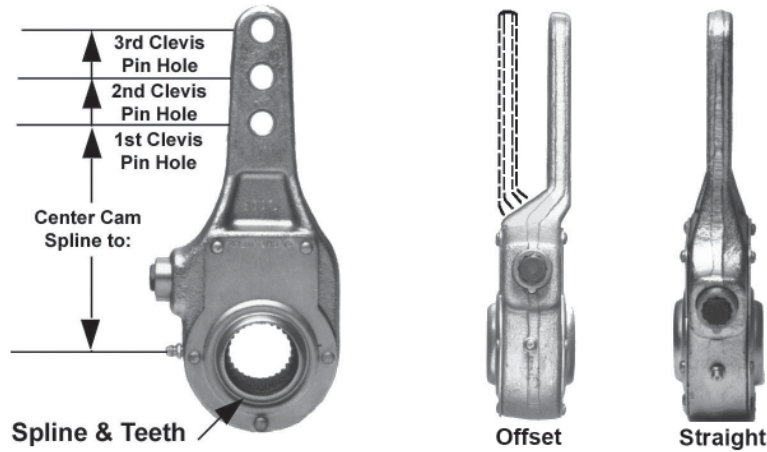

PART NUMBER	ARM LENGTH			STRAIGHT/ OFFSET	SPLINE DIA. & NO. OF TEETH	MAXIMUM TORQUE RATING (IN/ LBS)	REPLACES	CLEVIS PIN DIA.	REMARKS
	CENTER CAM SPLINE TO FIRST CLEVIS PIN HOLE	CENTER CAM SPLINE TO SECOND CLEVIS PIN HOLE	CENTER CAM SPLINE TO THIRD CLEVIS PIN HOLE						
R825007	4"	5"		Straight	1-1/4"-40	26,000		1/2"	
R825009	4"	5"		Straight	1-1/2"-48	26,000	E9105	1/2"	
R824009	4-1/2"	5-1/2"		Straight	1-1/4"-10	22,000	278302, E4904, KN48031	1/2"	Economy slack
R822008	5"	6"	7"	Straight	1-1/4"-10	22,000	10398, 10400, 10400BULK, 222477, 278303, E939, KN48001, L2495, M2582, S2021A	1/2"	
R823000	5"	6"	7"	Straight	1-1/2"-10	30,000	10393BULK, 1850, 18501, 18502, 2100, 212101, 212102, 212116, 222812, 2300, 27323, 278010, 278045, 278719, 6200, 63402, E1063HD, E1063HDBK, E2763, E612HD, E612HDBK, KN47081, KN52100, L196, L562, M10WR119, M16WR100, M16WR105, M435, M451, M452	1/2"	
R823002	5"	6"	7"	Straight	1-1/2"-28	30,000	101207, 101215, 10355, 10355HD, E2458HD, E2458HDBK, L1308, M638	1/2"	
R823005	5"	6"		LH 1-1/2"	1-1/2"-10	30,000	10357, 212113, 278106, 288542, E1116, E1116LH, L559, M16WR1002	1/2"	
R824000	5"	6"	7"	Straight	1-1/2"-10	22,000	10351BULK, E612BK, L196, M10WR119, M452	1/2"	Economy slack
R824003	5"	6"	7"	Straight	1-1/2"-28	22,000	E2458S	1/2"	Economy slack
A35-3275-J-1050	5-1/2"	6-1/2"		Straight	1-1/2"-10	30,000		5/8"	90° grease fitting
A6-3275-J-1050	5-1/2"	6-1/2"		Straight	1-1/2"-28	30,000		5/8"	

Note: Clevis not included with manual slack adjusters.  
30,000 in/lb. torque rated slack adjusters are gasket or o-ring sealed for corrosion protection.

# MANUAL SLACK ADJUSTERS

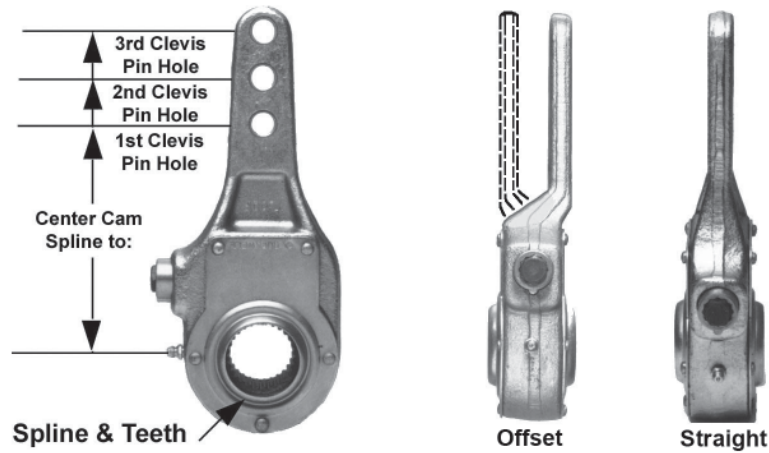

PART NUMBER	ARM LENGTH			STRAIGHT/ OFFSET	SPLINE DIA. & NO. OF TEETH	MAXIMUM TORQUE RATING (IN/ LBS)	REPLACES	CLEVIS PIN DIA.	REMARKS
	CENTER CAM SPLINE TO FIRST CLEVIS PIN HOLE	CENTER CAM SPLINE TO SECOND CLEVIS PIN HOLE	CENTER CAM SPLINE TO THIRD CLEVIS PIN HOLE						
R823001	5-1/2"	6-1/2"		Straight	1-1/2"-10	30,000	10366BULK, 18511, 278008, 278016, E940HD, E940HDBK, L2493, L845, M1064	1/2"	
R823003	5-1/2"	6-1/2"		Straight	1-1/2"-28	30,000	101214, 10368, 10368HD, 286740, 287899, E2459HD, E2459HDBK, L1648	1/2"	
R824001	5-1/2"	6-1/2"		Straight	1-1/2"-10	22,000	E940S	1/2"	Economy slack
R824004	5-1/2"	6-1/2"		Straight	1-1/2"-28	22,000	E2459S	1/2"	Economy slack
R825002	5-1/2"			Straight	1-1/4"-10	26,000		1/2"	
R825004	5-1/2"			LH 5/8"	1-1/4"-10	26,000		1/2"	
R825013	5-1/2"	6-1/2"		Straight	1-1/2"-28	26,000		5/8"	
R825017	5-1/2"			RH 5/8"	1-1/2"-28	26,000		5/8"	
R825018	5-1/2"			LH 5/8"	1-1/2"-28	26,000		5/8"	
R825020	5-1/2"			Straight	1-1/4"-24	26,000	E9102, E9602, L3225, S2024	1/2"	
R822007	6"			Straight	1-5/8"-37	22,000	10379, 10379BULK, 283411, 82070, E1574BK, H2012A, KN44041, S2012A	1/2"	
R823008	6"			Straight	1-5/8"-37	30,000	10367, 10367BULK, 18536, E1574HD, E1574HDBK, L841	1/2"	
R824007	6"			Straight	1-5/8"-37	22,000	E1574S	1/2"	Economy slack

Note: Clevis not included with manual slack adjusters.  
30,000 in/lb. torque rated slack adjusters are gasket or o-ring sealed for corrosion protection.



## MANUAL SLACK ALTERNATE NUMBER GUIDE

MERITOR PRODUCTION PART NO.	AFTERMARKET PART NO.	ECONOMY PART NO.	MERITOR PRODUCTION PART NO.	AFTERMARKET PART NO.	ECONOMY PART NO.
A4-3275-G-501	R823000		B30-3275-X-518	R825011	
A60-3275-G-501	R825000		B31-3275-X-518	R825012	
A61-3275-G-501	R825001		A10-3275-A-521	R823004	
A62-3275-G-501	R823000		A16-3275-A-521	R823005	
A69-3275-G-501	R822001	R935002	A4-3275-X-596	R823002	
B18-3275-G-501	R823001		A5-3275-X-596	R823003	
B64-3275-G-501	R823000		A6-3275-X-596	R822003	R824003
B98-3275-G-501	R822014	R824014	A7-3275-X-596	R822004	R824004
B99-3275-G-501	R822013	R824013	A11-3275-X-596	R825013	
C-3275-G-501	R825002		A17-3275-X-596	R823003	
C41-3275-G-501	R822009	R824009	A18-3275-X-596	R822004	R824004
C43-3275-G-501	R822009	R824009	A38-3275-X-596	R823002	
C46-3275-G-501	R825003		A44-3275-X-596	R823002	
C55-3275-G-501	R825004		A49-3275-X-596	R825014	
C56-3275-G-501	R825005		A50-3275-X-596	R825015	
C61-3275-G-501	R825006		A51-3275-X-596	R825016	
C62-3275-G-501	R823001		A53-3275-X-596	R823003	
C64-3275-G-501	R825007		A54-3275-X-596	R825017	
C65-3275-G-501	R825008		A55-3275-X-596	R825018	
C66-3275-G-501	R825009		A61-3275-X-596	R823002	
A5-3275-X-518	R823000		A62-3275-X-596	R823003	
A7-3275-X-518	R823000		A67-3275-X-596	R823002	
B19-3275-X-518	R823002		A90-3275-X-596	R825019	
B20-3275-X-518	R823003		A-3275-L-1052	R825020	
B22-3275-X-518	R825010		A20-3275-J-1050	R825014	

NOTE: This cross reference can only be used to find an alternate slack going from the Meritor Production number to the Aftermarket or Economy number. The Aftermarket and Economy parts have more application uses and therefore cannot be crossed back to the Meritor Production number.

# MANUAL SLACK ADJUSTER CLEVISES

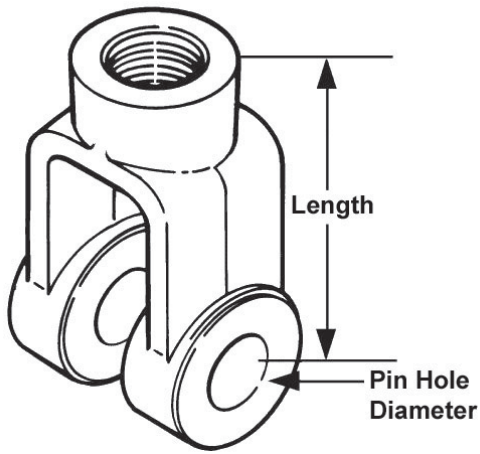

PART NUMBER	PIN HOLE DIAMETER	THREAD	LENGTH	CLEVIS TYPE	REPLACES
1245-C-185	1/2"	5/8"-18	1-13/16"	Straight	M1382
1245-K-193	1/2"	1/2"-20	1-13/16"	Straight	
1245-D-186	5/8"	5/8"-18	1-13/16"	Straight	
1245-S-201	3/4"	5/8"-18	2"	Straight	

# NUMERICAL PARTS LISTING

PART NUMBER	PAGE	PART NUMBER	PAGE	PART NUMBER	PAGE
1245-C-185.....	27	M807541.....	16	R802040.....	4
1245-D-186.....	27	M807542.....	17	R802041.....	4
1245-K-193.....	27	M807543.....	15	R802042.....	4
1245-S-201.....	27	M807544.....	16	R802043.....	4
A6-3275-J-1050.....	24	M807545.....	16	R802048.....	4
A35-3275-J-1050.....	24	M807546.....	17	R802051.....	4
M807000.....	13	M807547.....	17	R802052.....	4
M807001.....	12	M807548.....	15	R802060.....	4
M807002.....	12	M807549.....	15	R802061.....	4
M807003.....	12	M807550.....	17	R802062.....	4
M807004.....	12	M807551.....	15	R802063.....	4
M807005.....	13	M807552.....	16	R802070.....	5
M807006.....	13	M807553.....	17	R802071.....	5
M807007.....	13	M807554.....	16	R802072.....	4
M807008.....	13	M807555.....	16	R802073.....	4
M807009.....	11	M807556.....	15	R802074.....	5
M807010.....	11	M807557.....	17	R802075.....	5
M807011.....	11	M807558.....	17	R802260.....	5
M807012.....	11	M807559.....	15	R802261.....	5
M807013.....	14	M807560.....	15	R802281.....	5
M807014.....	14	M807563.....	17	R802292.....	5
M807015.....	14	M807564.....	17	R802293.....	5
M807016.....	12	M808000.....	19	R802300.....	5
M807017.....	12	M808001.....	19	R802301.....	5
M807018.....	12	M808002.....	18	R802310.....	5
M807019.....	14	M808003.....	18	R802311.....	5
M807020.....	14	M808004.....	18	R802316.....	5
M807021.....	14	M808005.....	18	R802317.....	5
M807022.....	12	M808006.....	19	R802320.....	5
M807023.....	12	M808007.....	18	R802321.....	5
M807024.....	12	M808012.....	18	R802354.....	6
M807025.....	11	M808013.....	19	R802355.....	6
M807026.....	12	M808015.....	19	R802380.....	6
M807500.....	11	M808019.....	19	R802400.....	6
M807501.....	11	M808021.....	19	R802401.....	6
M807502.....	11	M808022.....	18	R802402.....	6
M807503.....	11	M808023.....	18	R802403.....	6
M807504.....	11	M808024.....	18	R802412.....	6
M807505.....	11	R801001.....	4	R802413.....	6
M807507.....	11	R801002.....	4	R802414.....	6
M807508.....	11	R801003.....	4	R802415.....	6
M807521.....	17	R801004.....	4	R802416.....	6
M807522.....	17	R801040.....	5	R802421.....	6
M807523.....	17	R801041.....	5	R802422.....	6
M807524.....	17	R801042.....	6	R802423.....	6
M807525.....	16	R801043.....	5	R802430.....	6
M807526.....	16	R801070.....	6	R802431.....	6
M807527.....	15	R801071.....	7	R802440.....	7
M807528.....	16	R801072.....	7	R802441.....	7
M807529.....	16	R801073.....	7	R802444.....	7
M807530.....	17	R801079.....	7	R802445.....	7
M807531.....	17	R801101.....	7	R802446.....	7
M807532.....	16	R801102.....	7	R802447.....	7
M807533.....	16	R802000.....	4	R802462.....	7
M807534.....	17	R802001.....	4	R802463.....	7
M807535.....	15	R802021.....	4	R802486.....	7
M807536.....	15	R802023.....	4	R802487.....	7
M807537.....	16	R802030.....	4	R802490.....	7
M807538.....	16	R802031.....	4	R802491.....	7
M807539.....	17	R802032.....	4	R802512.....	7
M807540.....	17	R802033.....	4	R802513.....	7

# NUMERICAL PARTS LISTING

PART NUMBER	PAGE	PART NUMBER	PAGE	PART NUMBER	PAGE
R802610	7	R803071	4	R810318	21
R802611	7	R803101	4	R810319	21
R802630	7	R803102	4	R810320	21
R802631	7	R803104	5	R810321	21
R802644	5	R803105	5	R810322	21
R802645	5	R803106	6	R810323	21
R802656	4	R803108	6, 7	R810324	21
R802657	4	R803109	7	R810325	21
R802667	5	R803110	7	R810326	21
R803000	4	R803111	7	R810327	21
R803001	4	R803112	7	R810328	16, 17
R803002	4	R803113	7	R810329	17
R803003	4	R803114	7	R810330	15
R803004	4	R803115	7	R810331	17
R803005	4	R803116	7	R810333	17
R803008	4	R803195	5	R810336	17
R803009	4	R806001A	20	R822001	26
R803010	4	R806002A	20	R822003	26
R803010	4, 5	R806003A	20	R822004	26
R803011	4, 5	R806004A	20	R822007	25
R803016	5	R806016A	20	R822008	24
R803018	5	R806017A	20	R822009	26
R803019	5	R806018A	20	R822013	26
R803020	5	R806022A	20	R822014	26
R803021	5	R806023A	20	R823000	24, 26
R803022	5	R806024A	20	R823001	25, 26
R803023	5	R806026A	20	R823002	24, 26
R803024	5	R810005	8	R823003	25, 26
R803025	5	R810005LW	8	R823004	26
R803026	5	R810012	6	R823005	24, 26
R803027	5	R810013LW	4, 5, 6, 9	R823008	25
R803028	5	R810014LW	4, 5, 6, 9	R824000	24
R803030	6	R810015LW	4, 5, 6, 9	R824001	25
R803031	6	R810016LW	4, 5, 6, 9	R824003	24
R803036	6	R810018	4, 5, 6, 9	R824004	25
R803037	6	R810019	4, 5, 6, 7, 9	R824007	25
R803038	6	R810020	9	R824009	24
R803038	6	R810021	9	R825000	26
R803040	6	R810022	9	R825001	26
R803040	6	R810023	9	R825002	25, 26
R803041	6	R810024	4, 9	R825003	26
R803042	6	R810025	4, 5, 9	R825004	25, 26
R803043	6	R810300	11, 12, 17, 18, 20, 23	R825005	26
R803044	6	R810301	13, 14, 22	R825006	26
R803045	6	R810302	11, 12, 18, 19, 20, 22	R825007	24, 26
R803046	6, 7	R810303	11	R825008	26
R803047	6, 7	R810303	11, 22	R825009	24, 26
R803048	7	R810304	11, 16, 23	R825010	26
R803049	7	R810305	12, 15, 20, 23	R825011	26
R803050	7	R810306	12, 20, 23	R825012	26
R803051	7	R810307	13, 22	R825013	25, 26
R803052	7	R810308	14, 22	R825014	26
R803053	7	R810309	17, 23	R825015	26
R803054	7	R810310	22	R825016	26
R803055	7	R810311	11, 22	R825017	25, 26
R803056	7	R810312	15, 16, 17, 23	R825018	25, 26
R803057	7	R810313	23	R825019	26
R803058	7	R810314	11, 22	R825020	25, 26
R803059	7	R810315	15, 17, 23		
R803066	7	R810316	17, 21		
R803070	4	R810317	21		

## WARRANTY FEATURES FOR AUTOMATIC SLACK ADJUSTERS

<b>MERITOR PREMIUM CLEARANCE</b>			
<b>Product</b>	<b>Application</b>	<b>Years</b>	<b>Mileage</b>
Premium ASA M80700 - M807508	Line-Haul	6 years	1,000,000 miles
Premium S-ASA M808000 - M808508	Line-Haul	6 years	1,000,000 miles
Premium ASA M807521 - M807587	Intercity Transit	2 years	200,000 miles in service or 2 relines
Premium ASA TBC	Severe Duty	2 years	200,000 miles
Premium ASA M807521 - M807587	City Transit	1 year	100,000 miles in service or 2 relines

<b>MERITOR STANDARD CLEARANCE</b>			
<b>Product</b>	<b>Application</b>	<b>Years</b>	<b>Mileage</b>
Value ASA R806000A - R806508A	Line-Haul	2 years	200,000 miles in service or 2 relines

<b>MERITOR STROKE-SENSING</b>			
<b>Product</b>	<b>Application</b>	<b>Years</b>	<b>Mileage</b>
Stroke-Sensing sequences	Line-Haul	5 years	500,000 miles
	General Service	3 years	Unlimited
	Heavy Service	3 years	Unlimited
	Off-Highway Service	3 years	Unlimited

Please refer to publication SP-95155 for full vehicle application details.

Vehicle models, brands and names depicted herein are the property of their respective owners, and are not in any way associated with Meritor, Inc., or its affiliates.



Meritor Heavy Vehicle Systems, LLC  
7975 Dixie Highway  
Florence, Kentucky 41042 USA

888-725-9355 U.S.  
800-387-3889 Canada  
MeritorPartsOnline.com  
meritor.com

©2016 Meritor, Inc.  
Litho in USA, PB-1533  
Revised 04-16 (47865/70906)