

**VERGOKAN**

# UNISTRUT®

METAL FRAMING

Catalogue

A PART OF

**atkore**  
INTERNATIONAL



Image for illustrative purposes only

## Introduction

All Unistrut products in this catalogue are available through the Vergokan partner network in your country. Contact your local Vergokan representative for more information on availability and prices.

Unistrut has been the leading supplier of metal framing systems for over 90 years. Unistrut products and services are synonymous with engineering excellence and reliability worldwide.

## Part of the Atkore International family

Atkore is a major manufacturer and innovator with a unique focus on steel frame, pipe and electrical products. As part of the Atkore family we can draw on a variety of technologies, products and experience from Atkore companies throughout the world.



# Contents

---

Materials and finishes	4
------------------------	---

---

## 1. Metal Framing



---

Metal framing	6
Cantilevers	17

---

## 2. Channel nuts

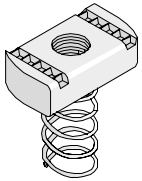

---

Channel nuts	18
--------------	----

---

## 3. Fittings

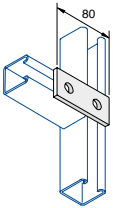

---

Fittings	21
----------	----

---

## 4. Pipe clamps

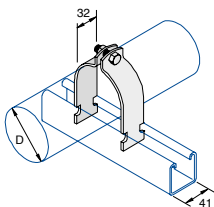

---

Pipe clamps	35
-------------	----

---

# Materials and Finishes



Image for illustrative purposes only

## Pre Galvanized

**PG**

Our most popular finish, generally used for internal applications. Pre Galvanized to Z275- BS EN 10346 1.0244 standards. Supplied with a zinc coating to a nominal coat between 10µm and 20µm.

## Plain Oil

**PO**

Plain oil to BS EN 10025 standards. Pickled & Oiled. Excellent for welding and finishing on site. Ideal base for powder coating and other surface finishes.

## Zinc Plated

**ZP**

An alternative to a Pre Galvanized product and generally used for internal applications. Again often used in sterile environments. Electroplated EN 12329.

## Hot Dip Galvanized

**HG**

Processed in accordance with BS EN ISO 1461: 2009. It is an excellent solution for outdoor environments and has a unique metallurgical structure which gives outstanding resistance to mechanical damage in transport, erection and service.

## Stainless Steel

**SS**

Stainless steel to 1.4404 (316L) and 1.4301 (304) standards. Excellent for marine applications, highly corrosive and extreme environmental conditions.

## Powder Coated

**PC**

A variety of powder coating finishes are available. Often used to provide a pleasing aesthetic finish such as shops and retail environments.

**Item references are build according to Vergokan logic:**

**PG** **ZP** No prefix

**HG** Prefix "HD"

**PO** Prefix "0"

**SS** Prefix "I4" or "I6"

## INTRODUCTION

Unistrut channels and fittings offer total flexibility in design and construction of assemblies for framing applications. Unistrut products are available in a range of materials and finishes. These finishes offer differing degrees of corrosion protection for use in a variety of environments. Where required, factory decorative finishes, <i.e., powder coating>, are available to order.

## MATERIALS

Channels are cold rolled from 1.5mm and 2.5mm steel strip and are available in:

- PO** PLAIN OILED
- PG** PRE - GALVANIZED
- HG** HOT DIP GALVANIZED
- SS** STAINLESS STEEL MARINE GRADE
- ZP** ELECTRO ZINC PLATED

Mild steel channels are rolled using material formed from BS EN 10025 with guaranteed yield 280N/mm<sup>2</sup> and minimum ultimate tensile strength of 370N/mm<sup>2</sup>.

Stainless steel channels are rolled using material formed from BS EN10088-2 grade 1.4404 (Grade 316L).

Unistrut fittings are pressed from hot rolled, pickled and oiled mild steel plate, or strip steel mainly from grade S315MC OR grade S275 mild steel.

Stainless steel fittings are available to EN10088-2 grade1.4404 (Grade 316L).

## FINISHES

### Hot -Dip Galvanized

Channels are Hot-Dip Galvanized in accordance with BS EN ISO1461:2009 and chromate passivated.

The minimum average Zinc Coating is as follows:

- Cold Rolled From 1.5mm Steel – 55 microns
- 2.5mm Steel – 55 microns

Fittings spun galvanized – 45 microns

### Pre-Galvanized

Pre-Galvanizing is to BS EN 10346 2004 (Coating Z275).

SPECIAL COATINGS AND MATERIAL GRADES ARE AVAILABLE ON REQUEST:

### Stainless Steel

- Stainless Steel 1.4301 (304)
- Stainless Steel 1.4404 (316L)
- On request: cleaned (Pickled & Passivated) Applying a pickling process to stainless steel results in a clean product and it also removes any heat discoloration that has occurred in the welding process.

### Serial number stamp

Genuine Unistrut channel is stamped with a serial number, and you'll see the words "Unistrut" and the corresponding part number stamped on the surface inside the channel as shown below.



## Zinc Electroplated

Channel nuts and bolts are zinc electroplated.

## RANGE

Channels are available in plain or continuous slotted (Code T), in multiple channel combinations and all 2.5mm channels have serrated lips. Slots, 14mm wide x 28mm long or 11mm wide x 25mm long, are provided at 50mm nominal centres. Combination channels manufactured from Pre-Galvanized Steel are spot welded, whilst Hot-Dip Galvanized channels are continuously seam welded or spot welded as appropriate.

## LENGTH

Standard channel lengths are 3m or 6m. Cut channel lengths can be supplied.

## WEIGHTS & DIMENSIONS

Weights published in this catalogue for all materials are approximate shipping weights. All dimensions are subject to commercial tolerance variations.

## TORQUE

The torque figures stated in this catalogue are based on using a properly calibrated torque wrench with a clean, dry (non-lubricated) Unistrut fitting, bolt and nut. A lubricated bolt or nut can cause extremely high tension in the connection and may lead to bolt failure. It must be noted that the accuracy of commercial torque wrenches varies widely and it is the responsibility of the installer to ensure that proper bolt torque has been achieved.

## PERFORMANCE

It should not be assumed that the performance of a stainless steel product is similar to that of its mild steel counterpart. Consult your local service centre for further information.

## FITTING APPLICATION

All part drawings illustrate only one application of each fitting. In most cases, many other applications are possible. Load values are based on use of a PNP12 Unistrut nut and M12 bolt unless specified otherwise.

While effort has been made to ensure the accuracy of the information contained in this catalogue at the time of publication, we cannot accept responsibility for inaccuracies resulting from undetected errors or omissions.

E & O.E. Unistrut Limited has a policy of continuous product development and reserve the right to change specifications without prior notice.

## STANDARDS

The standard requires that products are stamped with BSEN6946:1988 and also the name of the manufacturer.

We at Unistrut® show that the standard is achieved by rolling the channel with the part number along with the full name of the Standard BSEN6946:1988, and also our own UNISTRUT® branding.

This is, as it should be, stamped into the Channel to ensure that you can clearly identify our product over the inferior product that is creeping into the market place.

The engraving should also be clearly visible at all times, even when the product has under gone further finishing treatments i.e. Hot Dip Galvanized, Epoxy Coating.

Contractors and distributors should be aware of cheap imported and non-standard products that have removable or no product marking at all, as this is not within the Standard.

# 1. Metal Framing

Original Unistrut® Metal Framing

**VERGOKAN**  
**UNISTRUT®**

# Unistrut P1000

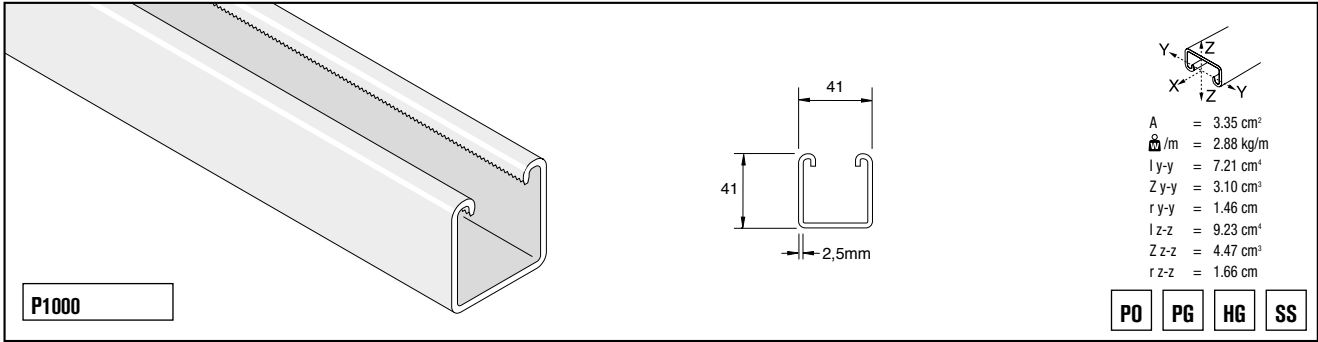

L(mm)	F		$f = 1/200L$	$f = 1/360L$	$F_{(kN)}$
	$F_{max}(kN)$	$f_{max}(mm)$	F (kN)	F (kN)	
250	17.354	0.23	-	-	16.608
500	8.672	0.95	-	-	16.187
750	5.778	2.15	-	5.602	15.245
1000	4.336	3.82	-	3.149	13.685
1250	3.463	5.97	-	2.011	12.086
1500	2.884	8.60	2.521	1.393	10.722
1750	2.472	11.70	1.844	1.020	9.575
2000	2.168	15.29	1.413	0.785	8.623
2250	1.923	19.35	1.118	0.618	7.819
2500	1.727	23.89	0.903	0.500	7.112
2750	1.570	28.91	0.746	0.412	6.504*
3000	1.442	34.40	0.628	0.343	5.995*

Article	Thickness (mm)	Length (mm)	Stock
OP1000X6	2,5	6000	✓
OP1000X3	2,5	3000	
P1000X6	2,5	6000	✓
P1000X3	2,5	3000	✓
HDP1000X6	2,5	6000	✓
HDP1000X3	2,5	3000	
IGP1000X6	2,5	6000	✓
IGP1000X3	2,5	3000	

\*180 ≤ kL/r < 250

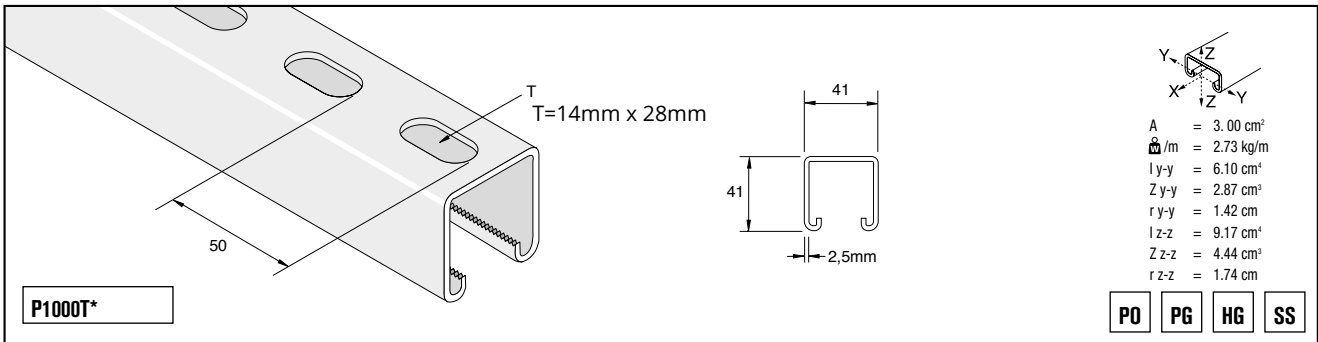

L(mm)	F		$f = 1/200L$	$f = 1/360L$	$F_{(kN)}$
	$F_{max}(kN)$	$f_{max}(mm)$	F (kN)	F (kN)	
250	16.069	0.27	-	-	16.283
500	8.034	1.05	-	-	16.039
750	5.356	2.35	-	4.738	15.274
1000	4.012	4.18	-	2.659	13.626
1250	3.208	6.54	3.071	1.707	11.880
1500	2.678	9.41	2.129	1.177	10.418
1750	2.296	12.81	1.560	0.863	9.231
2000	2.001	16.73	1.197	0.657	8.270
2250	1.785	21.18	0.942	0.520	7.465
2500	1.599	26.15	0.765	0.422	6.779
2750	1.452	31.64	0.628	0.343	6.190*
3000	1.334	37.65	0.530	0.294	5.670*

Article	Thickness (mm)	Length (mm)	Stock
OP1000TX6	2,5	6000	✓
P1000TX6	2,5	6000	✓
P1000TX3	2,5	3000	✓
HDP1000TX6	2,5	6000	✓
HDP1000TX3	2,5	3000	✓
IGP1000TX6	2,5	6000	✓
IGP1000TX3	2,5	3000	✓
I4P1000TX6	2,5	6000	✓
I4P1000TX3	2,5	3000	✓

\*180 ≤ kL/r < 250

# Unistrut P1001

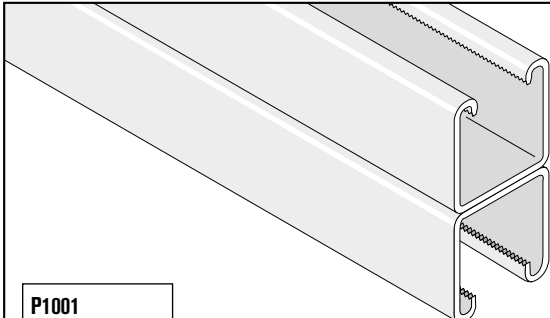

P1001

$A = 6.70 \text{ cm}^2$   
 $\rho/m = 5.77 \text{ kg/m}$   
 $I_{y-y} = 36.27 \text{ cm}^4$   
 $Z_{y-y} = 8.78 \text{ cm}^3$   
 $r_{y-y} = 2.32 \text{ cm}$   
 $I_{z-z} = 18.46 \text{ cm}^4$   
 $Z_{z-z} = 8.94 \text{ cm}^3$   
 $r_{z-z} = 1.66 \text{ cm}$

PO

PG

HG

SS

L(mm)	F		$\sigma=175 \text{ N/mm}^2$	$f=1/200L$	$f=1/360L$	$F_{(kN)}$
	$F_{max}(kN)$	$f_{max}(mm)$				
250	-	-	-	-	-	28.253
500	-	-	-	-	-	28.096
750	16.383	1.21	-	-	-	27.792
1000	12.292	2.15	-	-	-	27.301
1250	9.830	3.36	-	-	-	26.438
1500	8.191	4.84	-	-	7.044	25.025
1750	7.024	6.59	-	-	5.170	23.220
2000	6.141	8.61	-	-	3.963	21.288
2250	5.454	10.89	-	-	3.129	19.394
2500	4.915	13.45	4.562	-	2.531	17.619
2750	4.464	16.27	3.767	-	2.090	15.990
3000	4.091	19.37	3.169	-	1.756	14.519*

HG



Continuously Seam Welded

SS



Spot Welded

Article	Thickness (mm)	Length (mm)	Stock
HDP1001X6	2,5	6000	✓

\*180 ≤ kL/r < 250

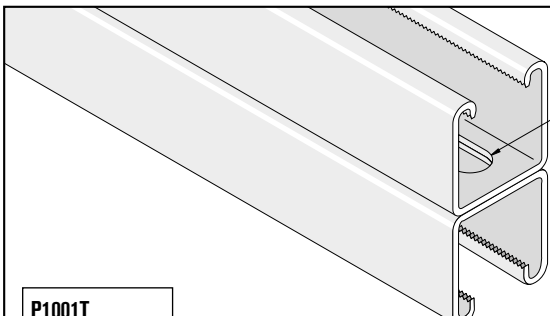

P1001T

T =  
14 x  
28 mm

$A = 6.00 \text{ cm}^2$   
 $\rho/m = 5.47 \text{ kg/m}$   
 $I_{y-y} = 36.21 \text{ cm}^4$   
 $Z_{y-y} = 8.77 \text{ cm}^3$   
 $r_{y-y} = 2.45 \text{ cm}$   
 $I_{z-z} = 18.34 \text{ cm}^4$   
 $Z_{z-z} = 8.88 \text{ cm}^3$   
 $r_{z-z} = 1.74 \text{ cm}$

PO

PG

HG

SS

L(mm)	F		$\sigma=175 \text{ N/mm}^2$	$f=1/200L$	$f=1/360L$	$F_{(kN)}$
	$F_{max}(kN)$	$f_{max}(mm)$				
250	-	-	-	-	-	27.458
500	-	-	-	-	-	27.311
750	16.363	1.21	-	-	-	27.027
1000	12.272	2.15	-	-	-	26.585
1250	9.820	3.36	-	-	-	25.830
1500	8.182	4.84	-	-	7.034	24.584
1750	7.014	6.59	-	-	5.170	22.906
2000	6.131	8.61	-	-	3.953	21.042
2250	5.454	10.90	-	-	3.120	19.198
2500	4.905	13.46	4.552	-	2.531	17.452
2750	4.464	16.28	3.767	-	2.090	15.8520
3000	4.091	19.38	3.159	-	1.756	14.391*

HG



Continuously Seam Welded

PO

PG

SS

Spot Welded

Article	Thickness (mm)	Length (mm)	Stock
P1001TX6	2,5	6000	✓
P1001TX3	2,5	3000	✓
HDP1001TX6	2,5	6000	✓
I6P1001TX6	2,5	6000	✓

\*180 ≤ kL/r < 250

Stated loadings apply to mild steel products only.



# Unistrut P3300

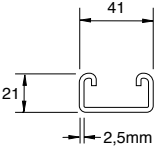

$A = 2.32 \text{ cm}^2$   
 $\rho/m = 1.91 \text{ kg/m}$   
 $I_{y-y} = 1.19 \text{ cm}^4$   
 $Z_{y-y} = 0.97 \text{ cm}^3$   
 $r_{y-y} = 0.71 \text{ cm}$   
 $I_{z-z} = 5.34 \text{ cm}^4$   
 $Z_{z-z} = 2.59 \text{ cm}^3$   
 $r_{z-z} = 1.51 \text{ cm}$

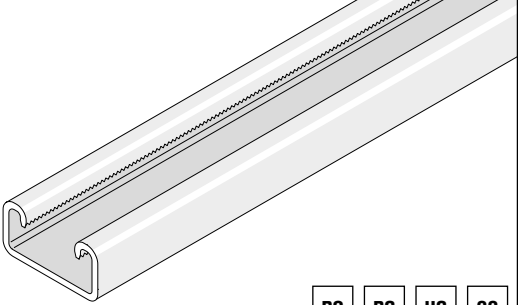

**P3300**

PO

PG

HG

SS

L(mm)	F		$f = 1/200L$	$f = 1/360L$	$F_{(kN)}$
	$F_{max}(kN)$	$f_{max}(mm)$	F (kN)	F (kN)	
250	5.425	0.45	-	-	10.222
500	2.708	1.81	-	2.080	9.761
750	1.805	4.07	1.658	0.922	8.427
1000	1.354	7.24	0.932	0.520	6.769
1250	1.079	11.32	0.598	0.324	5.376
1500	0.903	16.30	0.412	0.226	4.287*
1750	0.775	22.19	0.304	-	3.463*
2000	0.677	28.99	0.226	-	-

Article	Thickness (mm)	Length (mm)	Stock
0P3300X6	2,5	6000	✓
P3300X6	2,5	6000	✓
P3300X3	2,5	3000	
HDP3300X6	2,5	6000	
I6P3300X6	2,5	6000	✓

\* $180 \leq kL/r < 250$

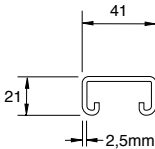

$A = 2.075 \text{ cm}^2$   
 $\rho/m = 1.76 \text{ kg/m}$   
 $I_{y-y} = 1.04 \text{ cm}^4$   
 $Z_{y-y} = 0.92 \text{ cm}^3$   
 $r_{y-y} = 0.71 \text{ cm}$   
 $I_{z-z} = 5.32 \text{ cm}^4$   
 $Z_{z-z} = 2.57 \text{ cm}^3$   
 $r_{z-z} = 1.61 \text{ cm}$

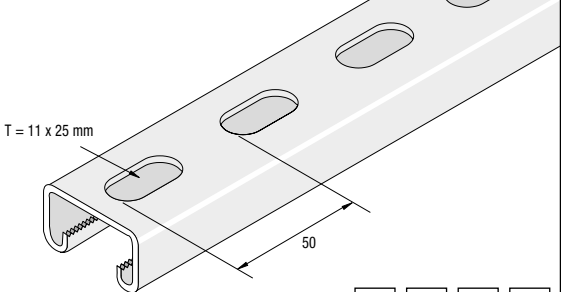

**P3300T10**

PO

PG

HG

SS

L(mm)	F		$f = 1/200L$	$f = 1/360L$	$F_{(kN)}$
	$F_{max}(kN)$	$f_{max}(mm)$	F (kN)	F (kN)	
250	5.152	0.49	-	-	-
500	2.576	1.97	-	1.819	-
750	1.717	4.42	1.455	0.809	-
1000	1.288	7.87	0.819	0.455	-
1250	1.030	12.29	0.524	0.291	-
1500	0.859	17.70	0.364	-	-
1750	0.736	24.09	0.267	-	-
2000	0.644	31.46	-	-	-

Article	Thickness (mm)	Length (mm)	Stock
P3300T10X6	2,5	6000	✓
P3300T10X3	2,5	3000	✓
HDP3300T10X6	2,5	6000	✓
HDP3300T10X3	2,5	3000	✓
I6P3300T10X6	2,5	6000	✓
I4P3300T10X6	2,5	6000	✓

Stated loadings apply to mild steel products only.

# Unistrut P3301

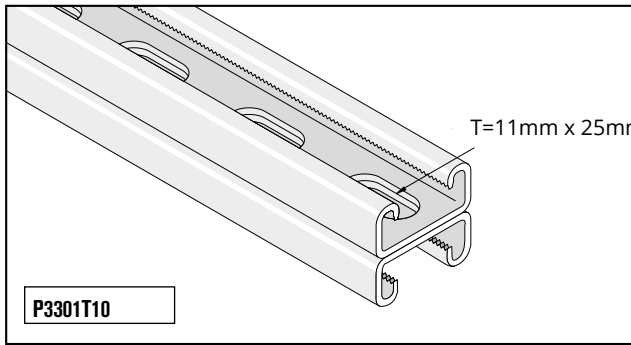
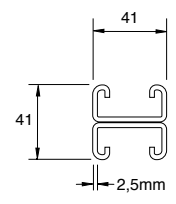
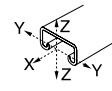



$A = 4.09 \text{ cm}^2$   
 $\rho/m = 3.53 \text{ kg/m}$   
 $I_{y-y} = 6.42 \text{ cm}^4$   
 $I_{z-z} = 10.64 \text{ cm}^4$   
 $r_{y-y} = 1.25 \text{ cm}$   
 $r_{z-z} = 1.61 \text{ cm}$

**PO** **PG** **HG** **SS**

L(mm)	F		$\sigma = 175 \text{ N/mm}^2$	$f = 1/200L$	$f = 1/360L$	$F_{Rd}$
	$F_{max}(kN)$	$f_{max}(mm)$				
250	16.632	0.26	-	-	-	17.266
500	8.316	1.03	-	-	-	17.030
750	5.544	2.31	-	-	4.991	16.599
1000	4.158	4.11	-	-	2.808	15.667
1250	3.326	6.43	3.234	1.797	-	14.156
1500	2.772	9.26	2.246	1.248	-	12.478
1750	2.376	12.60	1.650	0.917	-	10.899
2000	2.079	16.45	1.263	0.702	-	9.496
2250	1.848	20.83	0.998	0.555	-	8.289*
2500	1.663	25.71	0.809	0.449	-	7.250*
2750	1.512	31.11	0.668	0.371	-	6.377*
3000	1.386	37.02	0.562	0.312	-	-

**HG**  
 Continuously Seam Welded



**PO** **PG** **SS**  
 Spot Welded

Article	Thickness (mm)	Length (mm)	Stock
P3301T10X6	2,5	6000	✓
P3301T10X3	2,5	3000	✓
HDP3301T10X6	2,5	6000	✓
I6P3301T10X6	2,5	6000	

\*180 ≤ kL/r < 250

Stated loadings apply to mild steel products only.

# Unistrut P1100TTT

For the Unistrut profile P1100TTT we refer to the Vergokan range: MP3.41.41.200.3

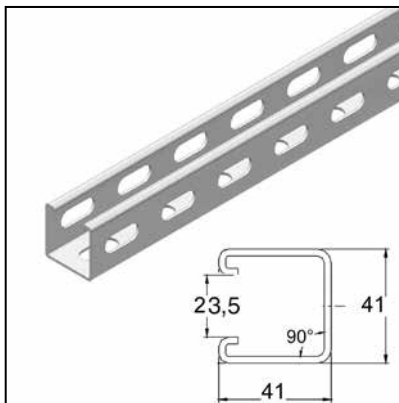

# Unistrut P1100T

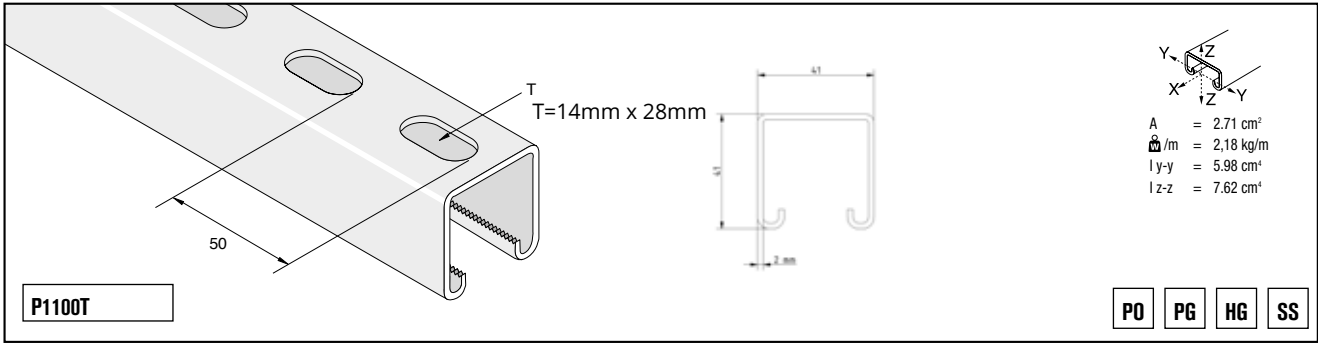

L(mm)	F		$\sigma=175 \text{ N/mm}^2$	$f=1/200L$	$f=1/360L$
	Fmax(kN)	fmax(mm)		F (kN)	F (kN)
250	16,115	0,27	-	-	-
500	8,058	1,07	-	-	-
750	5,372	2,41	-	-	-
1000	4,029	4,28	-	-	3,14
1250	3,223	6,69	3,01	-	2,01
1500	2,686	9,63	2,09	-	1,39
1750	2,302	13,11	1,54	-	1,02
2000	2,014	17,12	1,18	-	0,78
2250	1,791	21,67	0,93	-	0,62
2500	1,612	26,75	0,75	-	0,50
2750	1,465	32,37	0,62	-	0,41
3000	1,343	38,52	0,52	-	0,35

Article	Thickness (mm)	Length (mm)	Stock
P1100TX6	2	6000	✓
P1100TX3	2	3000	✓
HDP1100TX6	2	6000	✓

# Unistrut P3100T10

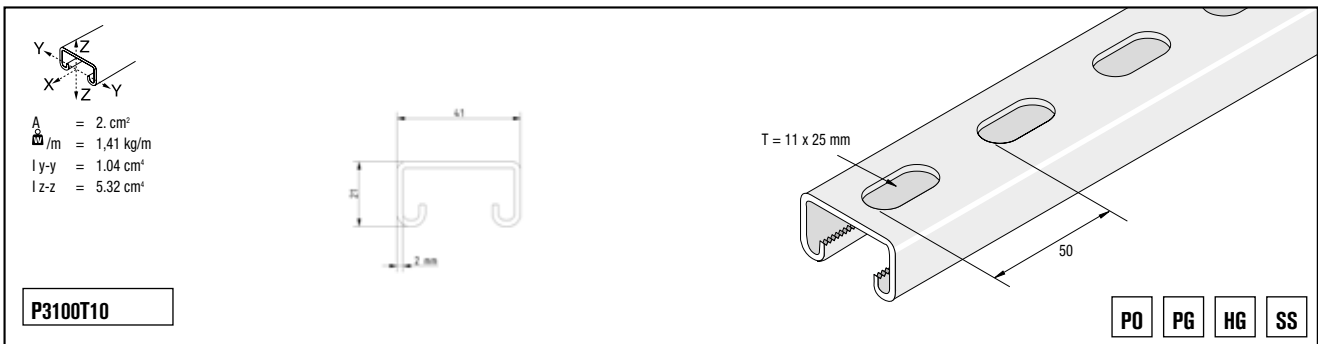

L(mm)	F		$\sigma=175 \text{ N/mm}^2$	$f=1/200L$	$f=1/360L$
	Fmax(kN)	fmax(mm)		F (kN)	F (kN)
250	4,760	0,51	-	-	-
500	2,380	2,03	-	-	2,15
750	1,586	4,57	1,43	-	0,96
1000	1,190	8,12	0,81	-	0,54
1250	0,952	12,69	0,52	-	0,34
1500	0,794	18,28	0,36	-	0,24
1750	0,680	24,88	0,26	-	0,18
2000	0,595	32,49	0,20	-	0,13

Article	Thickness (mm)	Length (mm)	Stock
P3100T10X6	2	6000	✓
P3100T10X3	2	3000	✓
HDP3100T10X6	2	6000	✓

Stated loadings apply to mild steel products only.

# Unistrut P2000 & 4000

**P2000T**

T=14mm x 28mm

50

41

1.5mm

Y  
X Z  
Y

A = 1.92 cm<sup>2</sup>  
 $\rho$ /m = 1.72 kg/m  
 I y-y = 4.24 cm<sup>4</sup>  
 Z y-y = 2.04 cm<sup>3</sup>  
 r y-y = 1.48 cm  
 I z-z = 6.10 cm<sup>4</sup>  
 Z z-z = 2.95 cm<sup>3</sup>  
 r z-z = 1.78 cm

**PO PG HG**

L(mm)	F		f=1/200L	f=1/360L	F <sub>允</sub>
	F <sub>max</sub> (kN)	f <sub>max</sub> (mm)			
250	11.42	0.26	-	-	11.35
500	5.71	1.06	-	-	10.87
750	3.81	2.40	-	3.30	10.65
1000	2.85	4.27	-	1.85	9.30
1250	2.28	6.68	2.13	1.18	7.79
1500	1.90	9.62	1.48	0.82	6.54
1750	1.63	13.10	1.09	0.60	5.55
2000	1.42	17.11	0.83	0.46	4.78
2250	1.27	21.65	0.66	0.36	4.17
2500	1.14	26.73	0.53	0.29	3.69
2750	1.03	32.35	0.43	0.24	3.30*
3000	0.95	38.50	0.36	0.21	3.05*

\* K. L/r = >180 < 250

Article	Thickness (mm)	Length (mm)	Stock
P2000TX6	1,5	6000	✓
P2000TX3	1,5	3000	

**P4000T10**

T= 11 x 25 mm

50

41

21

1.5mm

Y  
X Z  
Y

A = 1.34 cm<sup>2</sup>  
 $\rho$ /m = 1.16 kg/m  
 I y-y = 0.78 cm<sup>4</sup>  
 Z y-y = 0.71 cm<sup>3</sup>  
 r y-y = 0.76 cm  
 I z-z = 3.66 cm<sup>4</sup>  
 Z z-z = 1.77 cm<sup>3</sup>  
 r z-z = 1.65 cm

**PG**

L(mm)	F		f=1/200L	f=1/360L	F <sub>允</sub>
	F <sub>max</sub> (kN)	f <sub>max</sub> (mm)			
250	3.976	0.51	-	-	-
500	1.988	2.02	-	1.364	-
750	1.325	4.55	1.092	0.606	-
1000	0.994	8.09	0.614	0.341	-
1250	0.795	12.65	0.393	0.218	-
1500	0.663	18.21	0.273	-	-
1750	0.568	24.79	-	-	-
2000	0.497	32.38	-	-	-

Article	Thickness (mm)	Length (mm)	Stock
P4000T10X6	1,5	6000	✓
P4000T10X3	1,5	3000	✓

Stated loadings apply to mild steel products only.

# Unistrut P5000

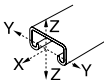

$A = 5.06 \text{ cm}^2$   
 $\rho/m = 4.05 \text{ kg/m}$   
 $I_{y-y} = 37.76 \text{ cm}^4$   
 $Z_{y-y} = 9.01 \text{ cm}^3$   
 $r_{y-y} = 2.72 \text{ cm}$   
 $I_{z-z} = 16.95 \text{ cm}^4$   
 $Z_{z-z} = 8.21 \text{ cm}^3$   
 $r_{z-z} = 1.82 \text{ cm}$

**P5000T**

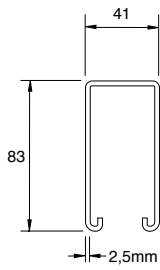

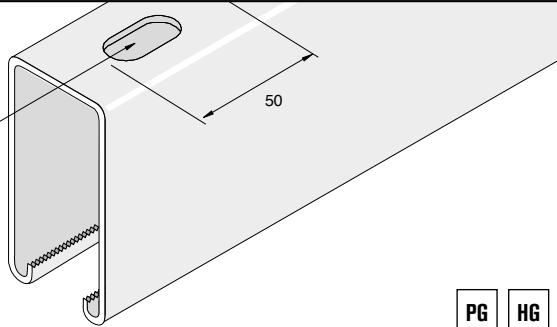

T = 14 x 28 mm

**PG** **HG**

L(mm)	F		f=1/200L	f=1/360L	F <sub>min</sub>
	F <sub>max</sub> (kN)	f <sub>max</sub> (mm)			
250	-	-	-	-	19.620
500	-	-	-	-	19.355
750	12.596	0.89	-	-	16.422
1000	9.447	1.59	-	-	12.822
1250	7.554	2.48	-	-	10.124
1500	6.298	3.58	-	-	8.182
1750	5.396	4.86	-	-	6.769
2000	4.719	6.36	-	4.120	5.719
2250	4.199	8.05	-	3.257	4.934
2500	3.777	9.93	-	2.639	4.326
2750	3.434	12.02	-	2.178	3.846
3000	3.149	14.31	-	1.834	3.453

Article	Thickness (mm)	Length (mm)	Stock
OP5000X6	2,5	6000	
P5000X6	2,5	6000	
P5000TX6	2,5	6000	
HDP5000TX6	2,5	6000	

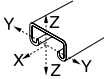

$A = 10.12 \text{ cm}^2$   
 $\rho/m = 8.11 \text{ kg/m}$   
 $I_{y-y} = 243.16 \text{ cm}^4$   
 $Z_{y-y} = 29.44 \text{ cm}^3$   
 $r_{y-y} = 4.90 \text{ cm}$   
 $I_{z-z} = 33.90 \text{ cm}^4$   
 $Z_{z-z} = 16.42 \text{ cm}^3$   
 $r_{z-z} = 1.83 \text{ cm}$

**P5001T**

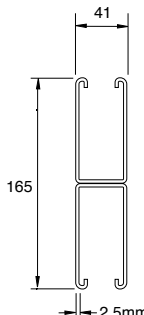

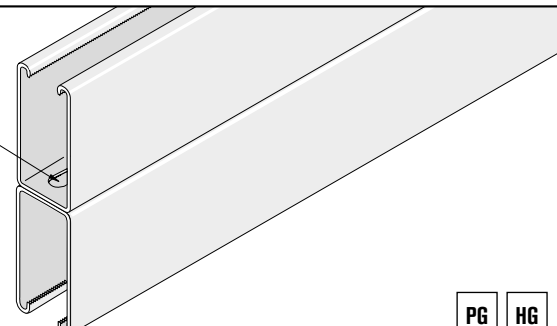

T = 14 x 28 mm

**PG** **HG**

L(mm)	F		f=1/200L	f=1/360L	F <sub>min</sub>
	F <sub>max</sub> (kN)	f <sub>max</sub> (mm)			
250	-	-	-	-	34.266
500	-	-	-	-	34.129
750	-	-	-	-	33.825
1000	-	-	-	-	33.432
1250	24.535	1.25	-	-	32.864
1500	20.444	1.80	-	-	32.010
1750	17.521	2.45	-	-	30.764
2000	15.333	3.20	-	-	29.165
2250	13.626	4.05	-	-	27.350
2500	12.263	5.00	-	-	25.467
2750	11.154	6.05	-	-	23.613
3000	10.222	7.21	-	-	21.847

**PG**

**HG**

Spot Welded



Article	Thickness (mm)	Length (mm)	Stock
P5001TX6	2,5	6000	

Stated loadings apply to mild steel products only.

# Unistrut P5500

**P5500T**

$A = 4.03 \text{ cm}^2$   
 $\rho/m = 3.60 \text{ kg/m}$   
 $I_{y-y} = 17.57 \text{ cm}^4$   
 $Z_{y-y} = 5.59 \text{ cm}^3$   
 $r_{y-y} = 2.09 \text{ cm}$   
 $I_{z-z} = 13.07 \text{ cm}^4$   
 $Z_{z-z} = 6.33 \text{ cm}^3$   
 $r_{z-z} = 1.79 \text{ cm}$

PG HG

L(mm)	F		$f = \frac{1}{200L}$	$f = \frac{1}{360L}$	$F_{min}$
	$F_{max}(kN)$	$f_{max}(mm)$	F (kN)	F (kN)	
250	-	-	-	-	20.277
500	-	-	-	-	20.081
750	9.928	1.50	-	-	18.443
1000	7.446	2.67	-	-	15.245
1250	5.955	4.18	-	4.944	12.557
1500	4.964	6.02	-	3.434	10.507
1750	4.248	8.19	-	2.521	8.966
2000	3.718	10.70	3.473	1.923	7.789
2250	3.306	13.55	2.747	1.521	6.867
2500	2.972	16.73	2.217	1.236	6.141
2750	2.708	20.24	1.834	1.020	5.543
3000	2.482	24.09	1.540	0.853	5.042

Article	Thickness (mm)	Length (mm)	Stock
P5500TX6	2,5	6000	✓
P5500TX3	2,5	3000	
P5500X6	2,5	6000	

**P5501T**

$A = 8.06 \text{ cm}^2$   
 $\rho/m = 7.21 \text{ kg/m}$   
 $I_{y-y} = 109.74 \text{ cm}^4$   
 $Z_{y-y} = 17.70 \text{ cm}^3$   
 $r_{y-y} = 3.69 \text{ cm}$   
 $I_{z-z} = 26.14 \text{ cm}^4$   
 $Z_{z-z} = 12.66 \text{ cm}^3$   
 $r_{z-z} = 1.80 \text{ cm}$

PG HG

L(mm)	F		$f = \frac{1}{200L}$	$f = \frac{1}{360L}$	$F_{min}$
	$F_{max}(kN)$	$f_{max}(mm)$	F (kN)	F (kN)	
250	-	-	-	-	34.747
500	-	-	-	-	34.590
750	-	-	-	-	34.257
1000	-	-	-	-	33.766
1250	-	-	-	-	32.971
1500	15.745	3.07	-	-	31.677
1750	13.499	4.18	-	-	29.822
2000	11.811	5.47	-	-	27.674
2250	10.497	6.92	-	9.476	25.457
2500	9.477	8.54	-	7.671	23.299
2750	8.584	10.34	-	6.337	21.288
3000	7.868	12.30	-	5.327	19.443

PG HG

Spot Welded

Spot welded unless otherwise noted.

Article	Thickness (mm)	Length (mm)	Stock
P5501TX6	2,5	6000	✓
HDP5501TX6	2,5	6000	

Stated loadings apply to mild steel products only.

# Unistrut P1000 Special Channels

P1000 Special Channels require a minimum order quantity - RFK

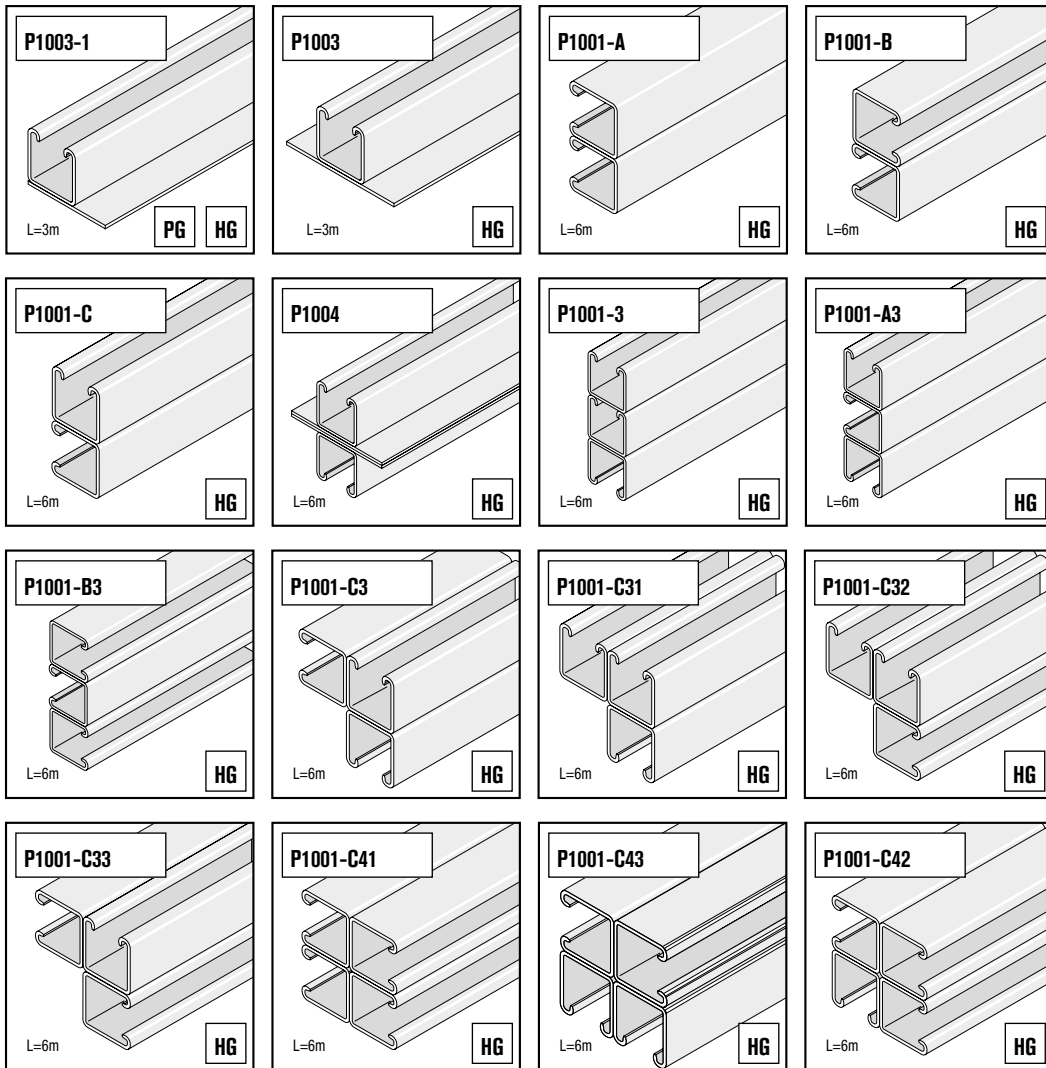

These items can be ordered on request (RFK).

# Concrete Inserts

RFK

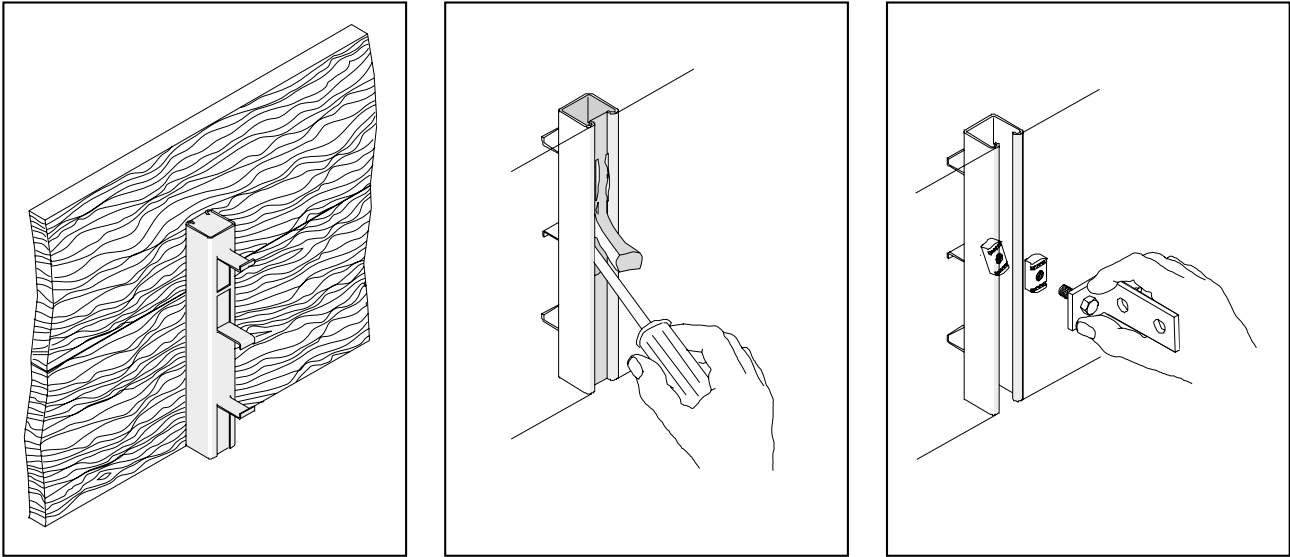

## Concrete Inserts

Unistrut concrete inserts are manufactured from the standard Unistrut channel and may be installed in floors, walls, or ceilings for the support of all types of piping, conduit, cable support, and other industrial equipment.

Unistrut channel nuts can be positioned anywhere along the length of the channel, providing a means of attaching fittings or rods where required.

Unistrut inserts are available pre-filled with an easily removable foam to prevent the ingress of grout and cement.

Concrete inserts can be supplied in pre galvanized, hot dip galvanized and stainless steel finishes.

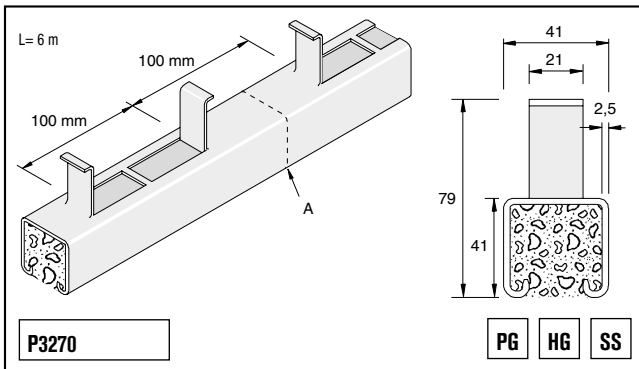

P3270 inserts are designed to accommodate M6, M8, M10, M12 & M16 fixings. Cutting positions are located between lugs as indicated (A) in increments of 200mm.

The recommended loading in average strength concrete\* with a safety factor of 3, is:

Part No.	Pullout	Length
P3270	8.8kN	300mm

\*B = 25 N/mm<sup>2</sup>

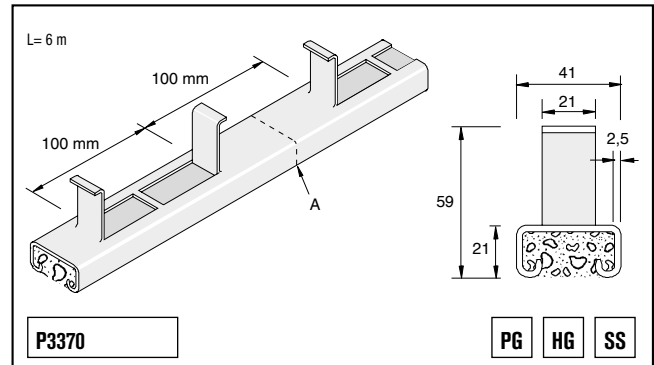

P3370 inserts are designed to accommodate M6, M8, M10 & M12 fixings. Cutting positions are located between lugs as indicated (A) in increments of 200mm

The recommended loading in average strength concrete\* with a safety factor of 3, is:

Part No.	Pullout	Length
P3370	6.7kN	300mm

\*B = 25 N/mm<sup>2</sup>









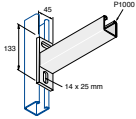

Stated loadings apply to mild steel products only  
These items can be ordered on request (RFK).

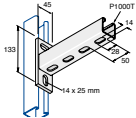
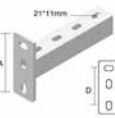
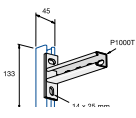
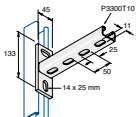
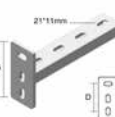
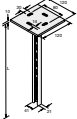

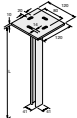
# Cantilevers

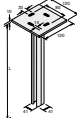
For the Unistrut cantilevers we refer to the Vergokan range.

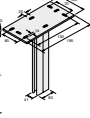
Conversion table

Unistrut	Vergokan	Remark
<b>P2663</b> 	<b>WKMP41.41</b> 	WKMP41.41 based on 2 mm channel instead of 2,5 mm for P2663
<b>P2663T</b> 	<b>WKMP41.41</b> 	WKMP41.41 based on 2 mm channel instead of 2,5 mm for P2663T
<b>P2668T</b> 		On demand via RFK request
<b>P2633T</b> 	<b>WKMP41.21</b> 	WKMP41.21 based on 2 mm channel instead of 2,5 mm for P2633T
<b>HBL</b> 	<b>HDHSLECL</b> 	
<b>HBM</b> 	<b>HSMES</b> 	
<b>HBLD</b> 	<b>HDHSLDCL</b> 	
<b>HBH</b> 	<b>HSMD</b> 	

## 2. Channel nuts

Original Unistrut® channel nuts

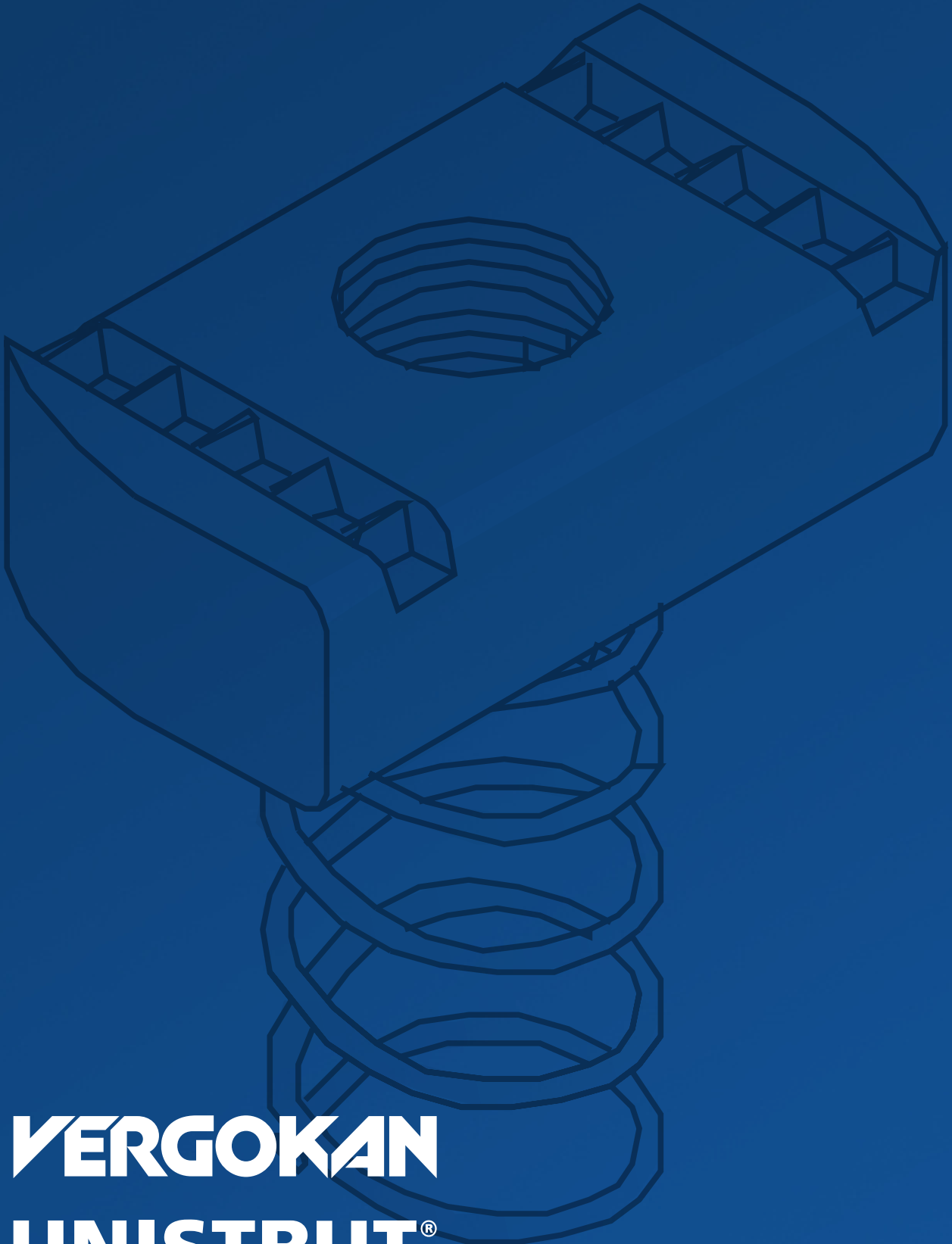

**VERGOKAN**  
**UNISTRUT®**

# Channel nuts

Suitable for P1000, P2000 & P3270

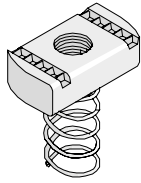

**PNL06-PNL12A**

**ZP HG SS**

Finish	Thread		Size	/100	/100	Stock		
	ZP	HG				SS	ZP	HG
PNL06	HDPNL06	I6PNL06	M6	3.26	100	✓	✓	✓
PNL08	HDPNL08	I6PNL08	M8	3.53	100	✓		
PNL10	HDPNL10	I6PNL10	M10	3.95	100	✓	✓	✓
PNL12	HDPNL12		M12	4.78	100	✓		✓
PNL12A	HDPNL12A	I6PNL12A	M12	3.43	100	✓	✓	

Suitable for P3300, P4000 & P3370

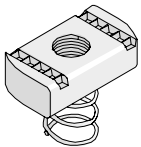

**PNS06-PNS12A**

**ZP HG SS**

Finish	Thread		Size	/100	/100	Stock		
	ZP	HG				SS	ZP	HG
PNS06	HDPNS06	I6PNS06	M6	3.1	100	✓		
PNS08	HDPNS08	I6PNS08	M8	3.5	100			
PNS10	HDPNS10	I6PNS10	M10	3.9	100	✓		
PNS12A	HDPNS12A	I6PNS12A	M12	3.6	100			

Suitable for P1000, P2000, P3300, P4000, P5000, P5500, P3270 & P3370

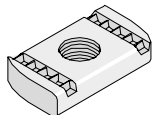

**PNP06-PNP12A**

**ZP HG SS**

Finish	Thread		Size	/100	/100	Stock		
	ZP	HG				SS	ZP	HG
PNP06	HDPNP06	I6PNP06	M6	3.10	100	✓	✓	✓
PNP08	HDPNP08	I6PNP08	M8	3.40	100	✓	✓	✓
PNP10	HDPNP10	I6PNP10	M10	3.80	100	✓	✓	✓
PNP12	HDPNP12		M12	4.68	100	✓		✓
PNP12A	HDPNP12A	I6PNP12A	M12	3.43	100	✓	✓	✓

\* PNP12 is not suitable for Unistrut channels P3300, P4000 & P3370

Suitable for P1000, P5000, P5500 & P3270

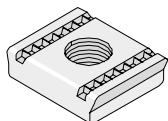

**PNP16**

**ZP**

Finish	Thread	Size	/100	/100	Stock
PNP16	M16	8.00	100		✓

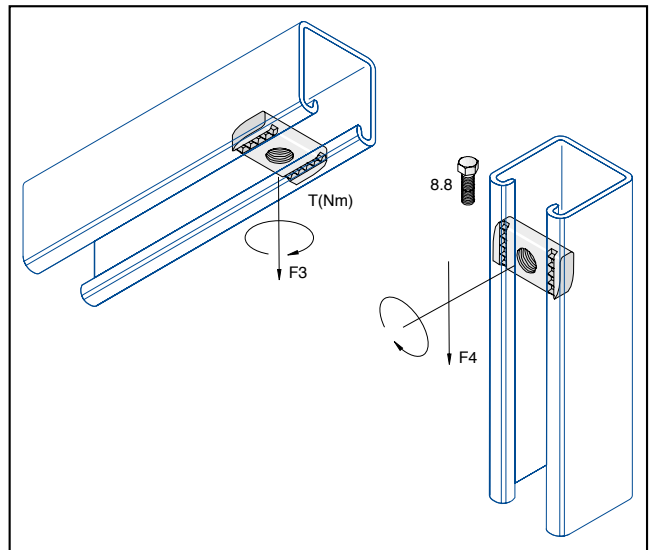

	Part No.	T (Nm)	F3 kN	Stock
P1000 41	PNP06	12	4.70	✓
	PNP08	28	5.28	✓
	PNP10	55	6.86	✓
	PNP12	70	8.82	✓
	PNP16	125	10.30	✓
	M16SN*	95	8.82	✓
P3300 41	PNP06	12	4.70	✓
	PNP08	28	5.78	✓
	PNP10	55	6.86	✓
	PNP12A	60	6.86	✓
	M16SN*	95	8.82	✓
P4000 41	PNP06	12	3.33	✓
	PNP08	28	3.53	✓
	PNP10	40	3.92	✓
	PNP12A	60	4.41	✓
	M16SN*	40	3.92	✓

	Part No.	T (Nm)	F3 kN	Stock
P1000 41	I6PNP06	6.5	2.45	✓
	I6PNP08	16	4.41	✓
	I6PNP10	31.5	6.86	✓
	I6PNP12A	55	6.86	✓
	I6PNP16	125	10.30	✓
P3300 41	I6PNP06	6.5	2.45	✓
	I6PNP08	16	4.41	✓
	I6PNP10	31.5	6.86	✓
	I6PNP12A	55	6.86	✓

\*M16SN Hot forged

# Unistrut

## Stud Nuts

Finish	L		Stock
ZP			
M6X30SN	18.5mm	100	

Finish	L		Stock
ZP			ZP
SS			SS
M8X30SN	15.5mm	100	
M8X40SN	25.5mm	100	
M8X50SN	35.5mm	100	
M8X60SN	45.5mm	100	
M8X75SN	60.5mm	100	
M8X100SN	85.5mm	100	

Finish	L		Stock
ZP			ZP
SS			SS
M10X30SN	13mm	100	
M10X40SN	23mm	100	
M10X50SN	33mm	100	
M10X60SN	43mm	100	
M10X75SN	68mm	100	
M10X100SN	83mm	100	

Finish	L		Stock
ZP			ZP
SS			SS
M12X30SN	11mm	100	
M12X40SN	21mm	100	
M12X50SN	31mm	100	
M12X60SN	41mm	100	
M12X75SN	56mm	100	
M12X100SN	81mm	100	

Finish	L		Stock
ZP			
M16X63SN*	40mm	100	
M16X102SN*	79mm	100	

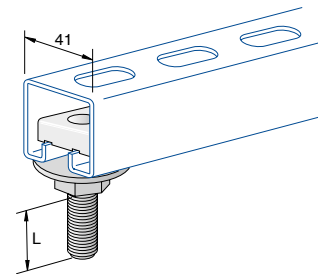
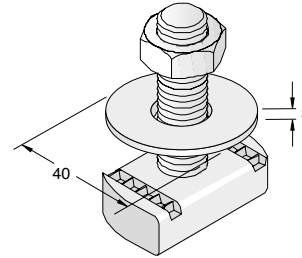

SN

ZP SS

\* Hot forged

# 3. Fittings

Original Unistrut® fittings

051

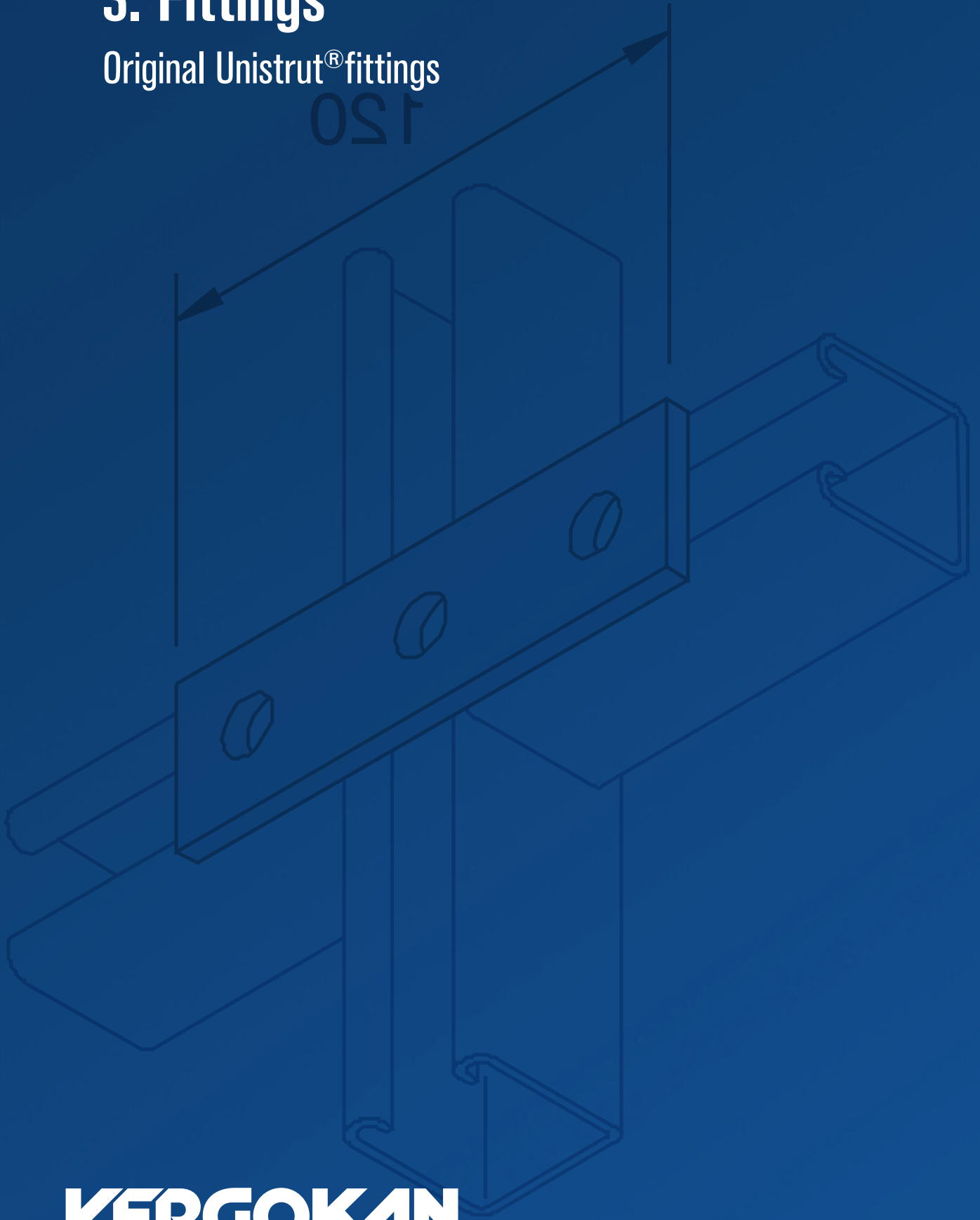

**VERGOKAN**  
**UNISTRUT®**

# Fittings

## Flat Fittings

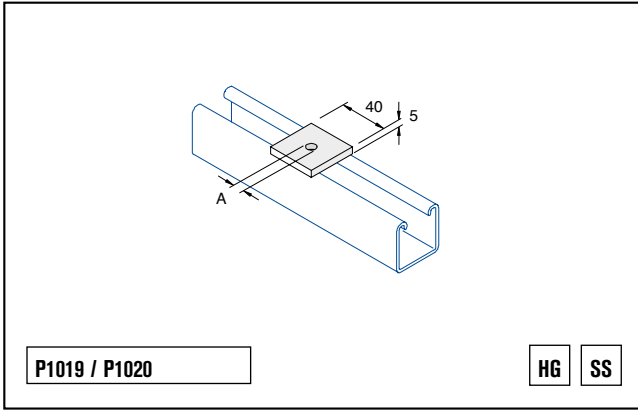

**P1019 / P1020**

**HG SS**

Finish		(mm)				Stock	
HG	SS	A				HG	SS
HDP1019	I6P1019	9	M6/M8	0.06	100	✓	✓
HDP1020	I6P1020	13	M10/M12	0.06	100	✓	✓

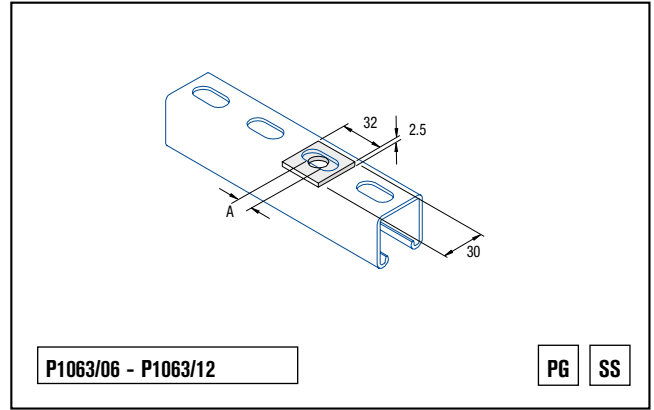

**P1063/06 - P1063/12**

**PG SS**

Finish		(mm)				Stock	
PG	SS	A				PG	SS
P1063/06	I6P1063/06	8	M6	0.02	100		
P1063/08	I6P1063/08	10	M8	0.02	100		
P1063/10	I6P1063/10	12	M10	0.02	100	✓	
P1063/12	I6P1063/12	14	M12	0.02	100		

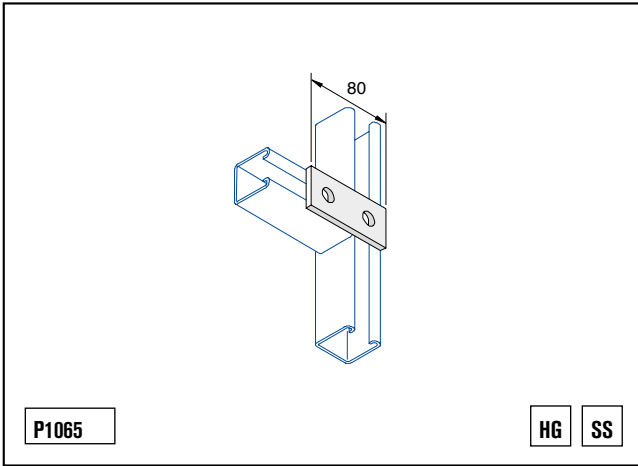

**P1065**

**HG SS**

Finish		(mm)			Stock	
HG	SS	A			HG	SS
HDP1065	I6P1065	8		0.17	20	✓

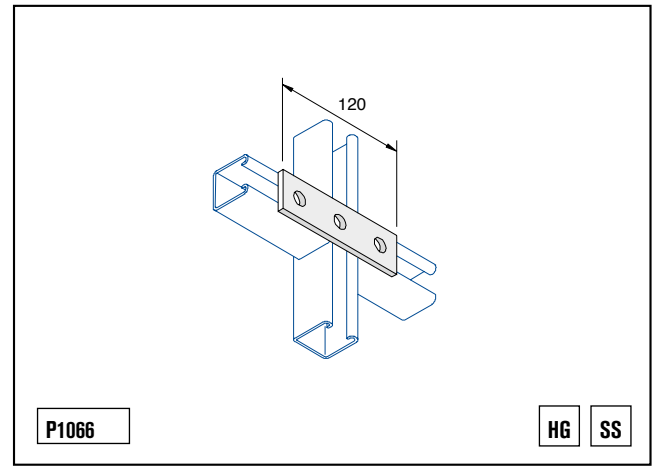

**P1066**

**HG SS**

Finish					Stock	
HG	SS				HG	SS
HDP1066	I6P1066		0.25	20	✓	

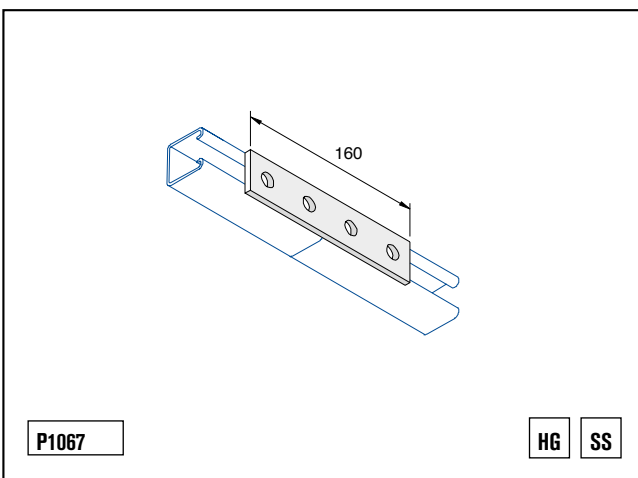

**P1067**

**HG SS**

Finish					Stock	
HG	SS				HG	SS
HDP1067	I6P1067		0.35	20	✓	✓

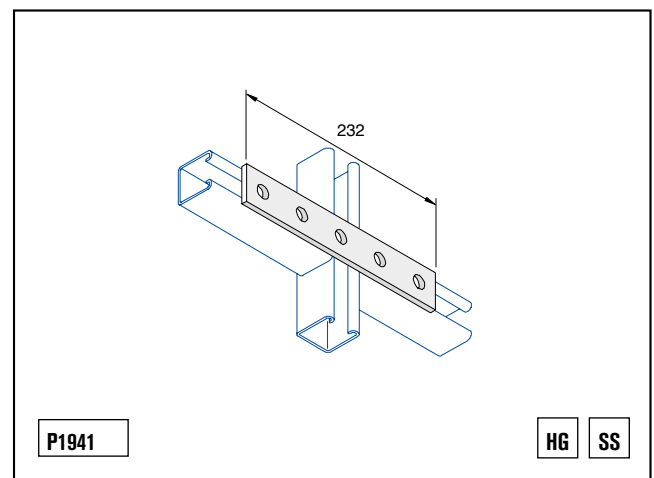

**P1941**

**HG SS**

Finish					Stock	
HG	SS				HG	SS
HDP1941	I6P1941		0.43	20	✓	

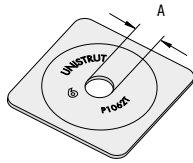

P1062T/P1064T

PG

Finish	(mm)				Stock
PG	A		/100		
P1062T	8	M6	3.0	100	✓
P1062AT	10	M8	3.0	100	✓
P1063T	12	M10	3.0	100	✓
P1064T	14	M12	3.0	100	✓

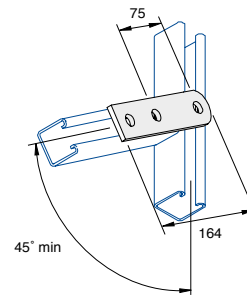

P2322

HG

Finish			Stock
HG			
HDP2322	0.34	25	

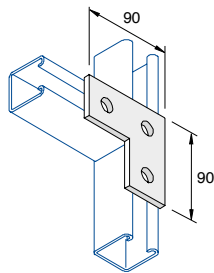

P1036

HG SS

Finish			Stock	
HG			HG	SS
HDP1036	0.26	25	✓	✓

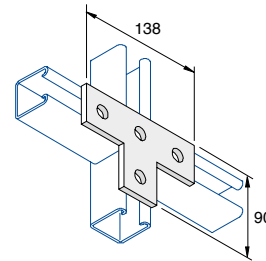

P1031

HG SS

Finish			Stock	
HG			HG	SS
HDP1031	0.36	25	✓	

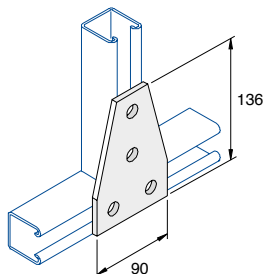

P1358

HG SS

Finish			Stock	
HG			HG	SS
HDP1358	0.48	10	✓	

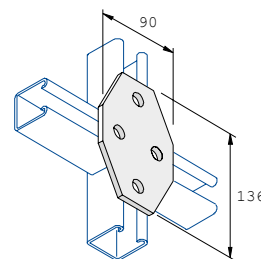

P1580

HG SS

Finish			Stock	
HG			HG	SS
HDP1580	0.37	10		

# Unistrut

## Angle Fittings

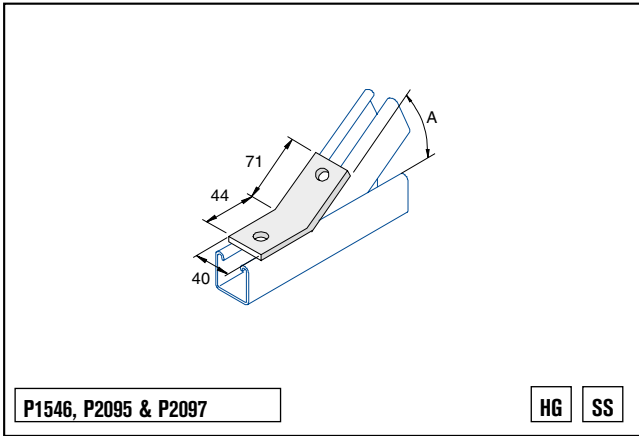

Finish	SS	A°	Weight	Box Qty	Stock	
					HG	SS
HDP1546	I6P1546	45°	0.26	25	✓	
HDP2097	I6P2097	60°	0.26	25	✓	
HDP2095	I6P2095	75°	0.26	25		

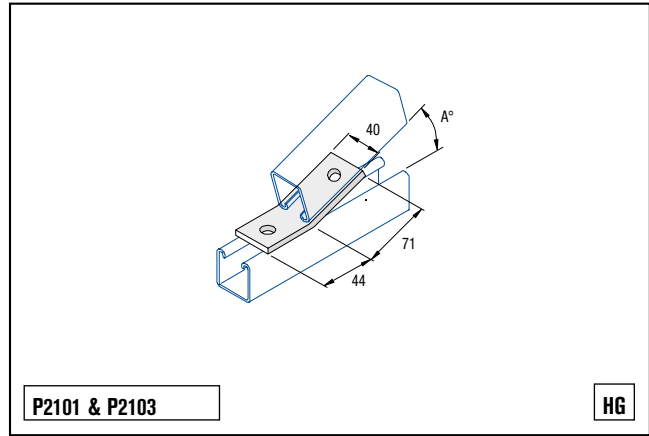

Finish	A°	Weight	Box Qty	Stock
HG				
HDP2101	30°	0.26	25	
HDP2103	15°	0.26	25	

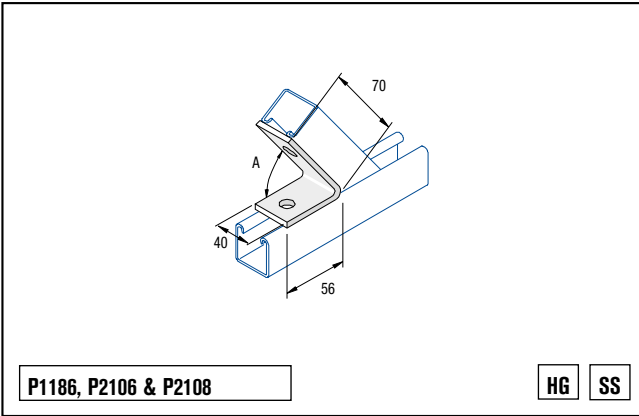

Finish	SS	A°	Weight	Box Qty	Stock	
					HG	SS
HDP1186	I6P1186	45°	0.26	25	✓	
HDP2106	I6P2106	75°	0.26	25		
HDP2108	I6P2108	60°	0.26	25		

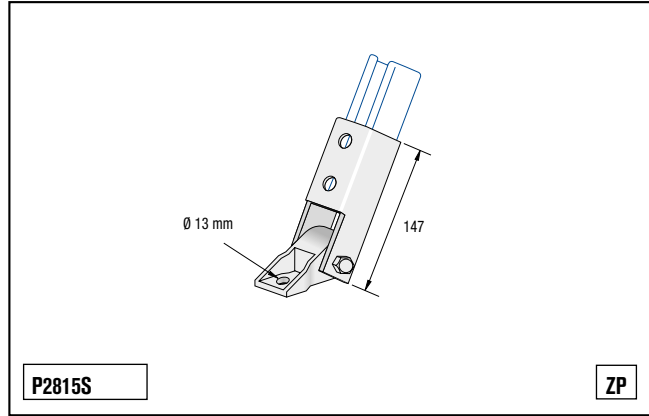

Finish	Weight	Box Qty	Stock
ZP			
P2815S	1.53	10	✓

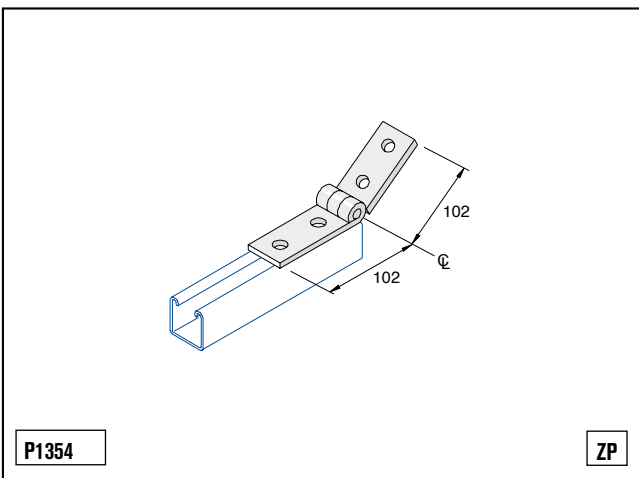

Finish	Weight	Box Qty	Stock
ZP			
P1354	0.45	20	

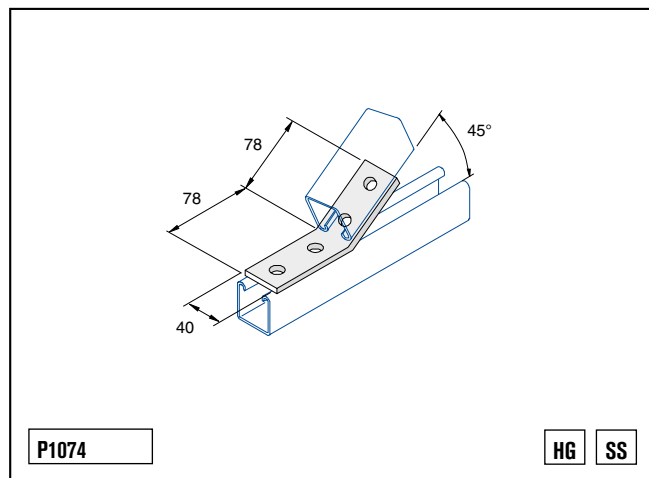

Finish	SS	Weight	Box Qty	Stock	
				HG	SS
HG					
HDP1074	I6P1074	0.35	25	✓	



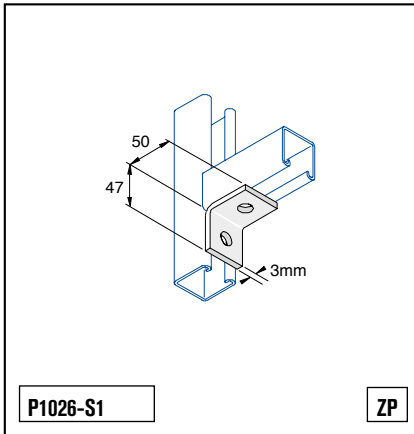

Finish		Weight	Stock	Stock	
ZP				HG	SS
P1026-S1		0.07	100	✓	

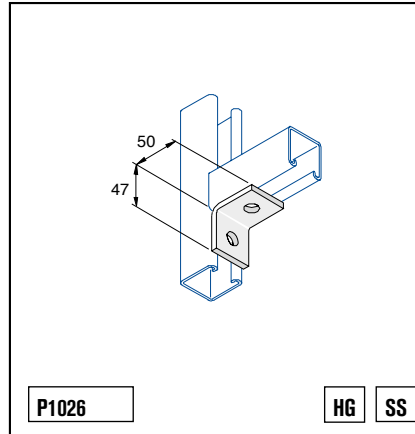

Finish		Weight	Stock	Stock	
HG	SS			HG	SS
HDP1026	I6P1026	0.17	100	✓	✓

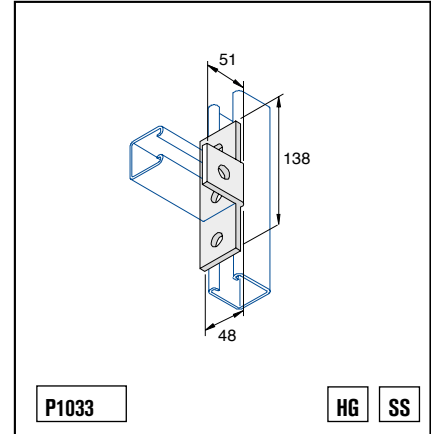

Finish		Weight	Stock	Stock	
HG	SS			HG	SS
HDP1033	I6P1033	0.36	25	✓	

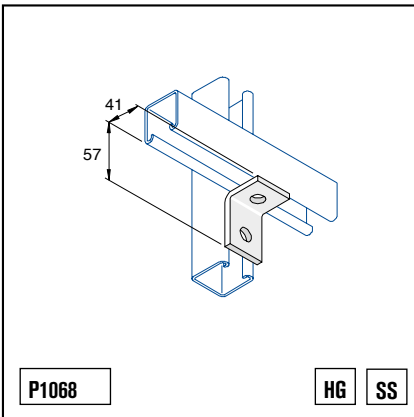

Finish		Weight	Stock	Stock	
HG	SS			HG	SS
HDP1068	I6P1068	0.17	25	✓	✓

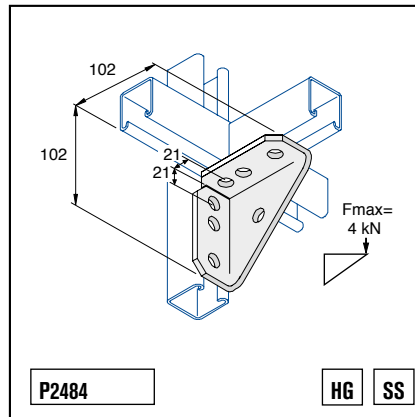

Finish		Weight	Stock	Stock	
HG	SS			HG	SS
HDP2484	I6P2484	0.61	10	✓	

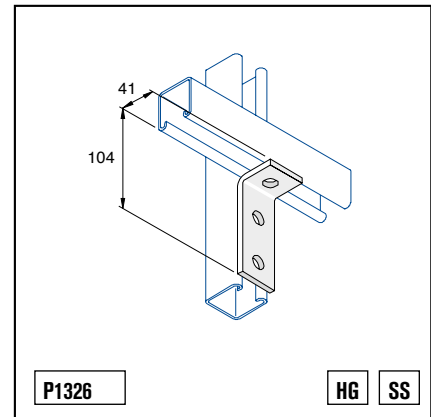

Finish		Weight	Stock	Stock	
HG	SS			HG	SS
HDP1326	I6P1326	0.26	25	✓	✓

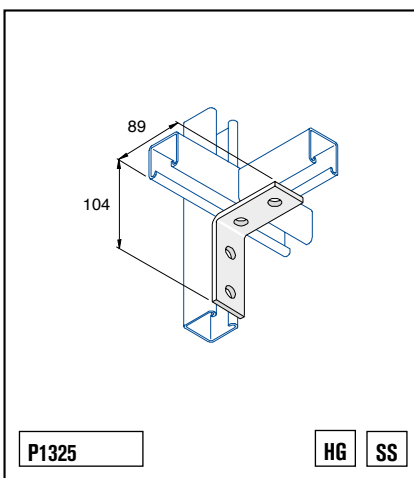

Finish		Weight	Stock	Stock	
HG	SS			HG	SS
HDP1325	I6P1325	0.35	25	✓	✓

Stated loadings apply to mild steel products only.

# Unistrut

## 90° Angle Fittings

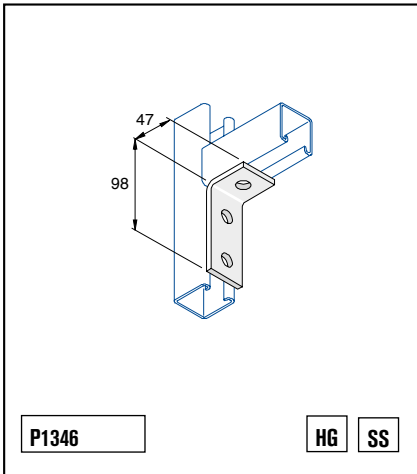

**P1346**

**HG SS**

Finish		Weight	Volume	Stock	
HG	SS			HG	SS
HDP1346	I6P1346	0.26	25	✓	

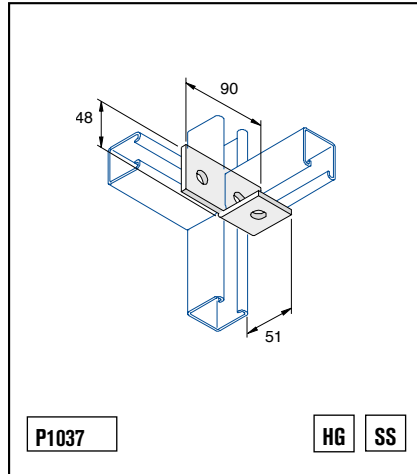

**P1037**

**HG SS**

Finish		Weight	Volume	Stock	
HG	SS			HG	SS
HDP1037	I6P1037	0.26	25	✓	

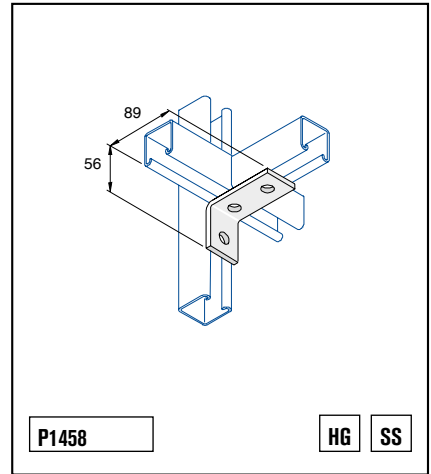

**P1458**

**HG SS**

Finish		Weight	Volume	Stock	
HG	SS			HG	SS
HDP1458	I6P1458	0.26	25	✓	

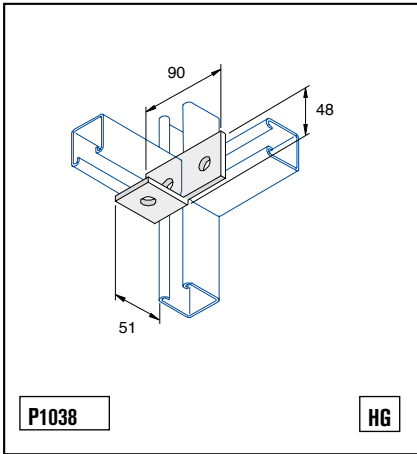

**P1038**

**HG**

Finish		Weight	Volume	Stock	
HG	SS			HG	SS
HDP1038		0.26	25		

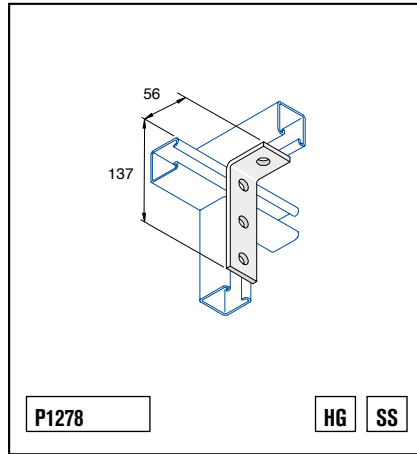

**P1278**

**HG SS**

Finish		Weight	Volume	Stock	
HG	SS			HG	SS
HDP1278	I6P1278	0.26	25	✓	

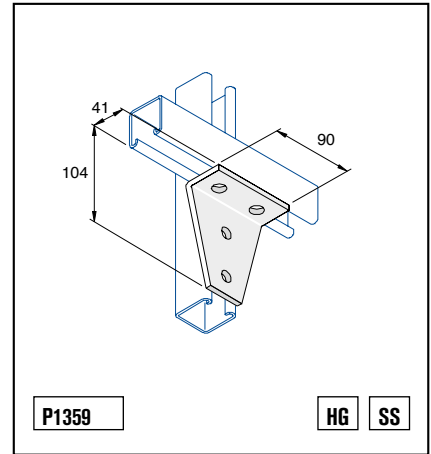

**P1359**

**HG SS**

Finish		Weight	Volume	Stock	
HG	SS			HG	SS
HDP1359	I6P1359	0.48	25	✓	

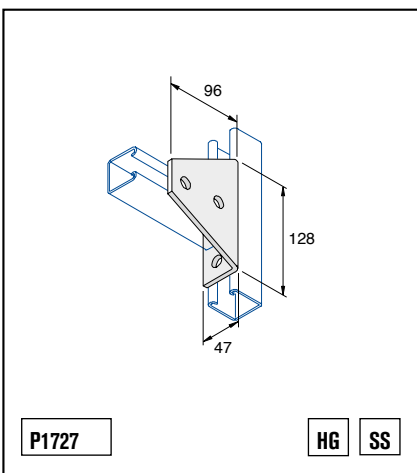

**P1727**

**HG SS**

Finish		Weight	Volume	Stock	
HG	SS			HG	SS
HDP1727	I6P1727	0.70	10	✓	

Stated loadings apply to mild steel products only.

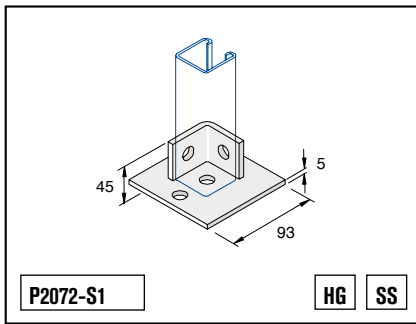

Finish		Weight	Stock	Stock	
HG	SS			HG	SS
HDP2072-S1	I6P2072-S1	0.48	10	✓	✓

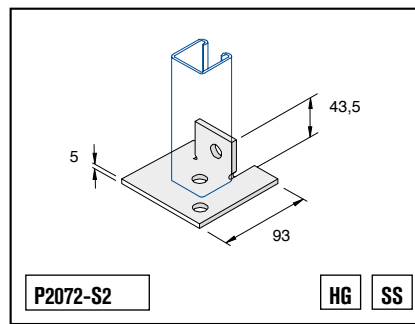

Finish		Weight	Stock	Stock	
HG	SS			HG	SS
HDP2072-S2	I6P2072-S2	0.33	10	✓	✓

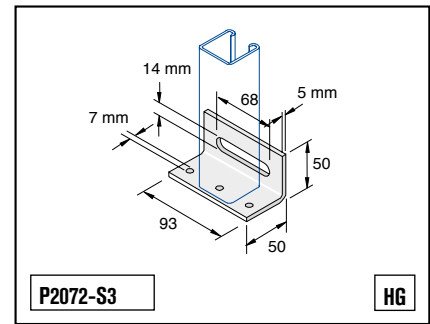

Finish		Weight	Stock	Stock	
HG	SS			HG	SS
HDP2072-S3		0.30	10	✓	✓

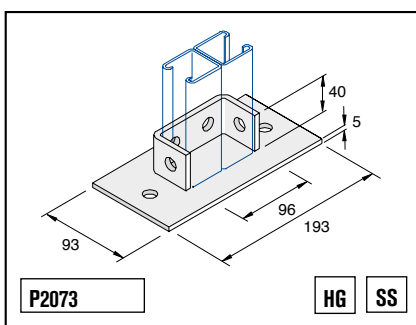

Finish		Weight	Stock	Stock	
HG	SS			HG	SS
HDP2073	I6P2073	0.98	10	✓	✓

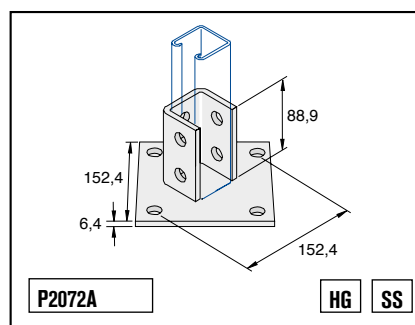

Finish		Weight	Stock	Stock	
HG	SS			HG	SS
HDP2072A	I6P2072A	1.70	10	✓	✓

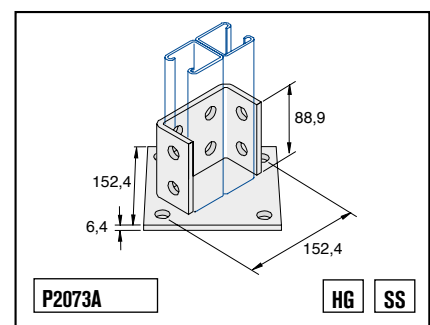

Finish		Weight	Stock	Stock	
HG	SS			HG	SS
HDP2073A	I6P2073A	1.80	10	✓	✓

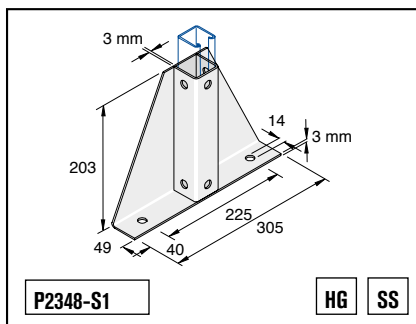

Finish		Weight	Stock	Stock	
HG	SS			HG	SS
P2348-S1	I6P2348-S1	1.95	1	✓	✓

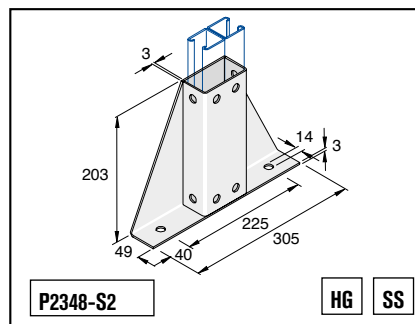

Finish		Weight	Stock	Stock	
HG	SS			HG	SS
HDP2348-S2	I6P2348-S2	2.15	1	✓	✓

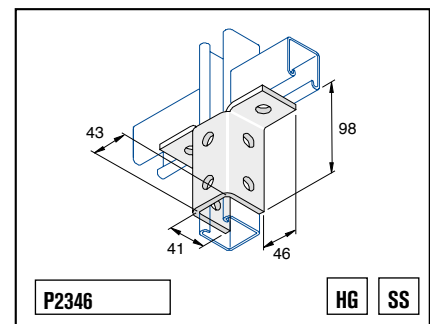

Finish		Weight	Stock	Stock	
HG	SS			HG	SS
HDP2346	I6P2346	0.68	10	✓	✓

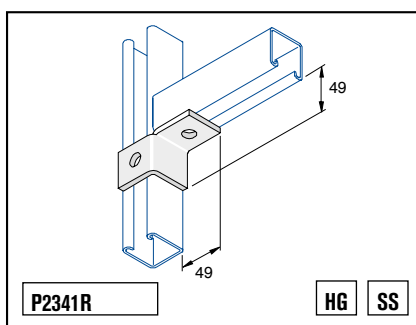

Finish		Weight	Stock	Stock	
HG	SS			HG	SS
HDP2341R	I6P2341R	0.21	25	✓	✓

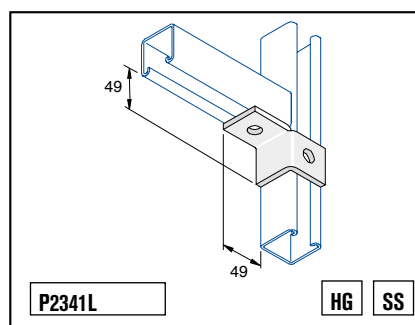

Finish		Weight	Stock	Stock	
HG	SS			HG	SS
HDP2341L	I6P2341L	0.21	25	✓	✓

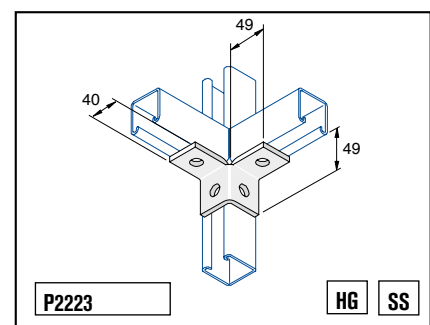

Finish		Weight	Stock	Stock	
HG	SS			HG	SS
HDP2223	I6P2223	0.35	25	✓	✓

# Unistrut

## U & Z Fittings & Channel Couplers

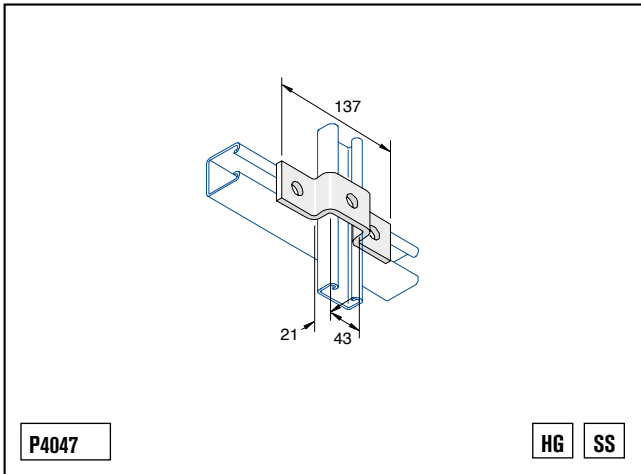

Finish		Weight	Box Qty	Stock	
HG	SS			HG	SS
HDP4047	I6P4047	0.32	25	✓	

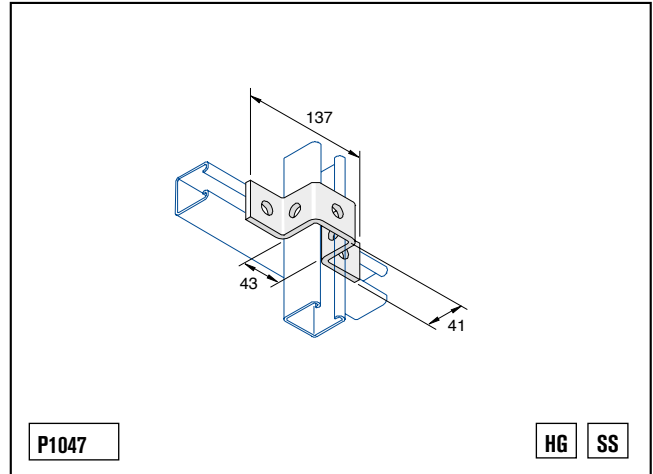

Finish		Weight	Box Qty	Stock	
HG	SS			HG	SS
HDP1047	I6P1047	0.40	25	✓	

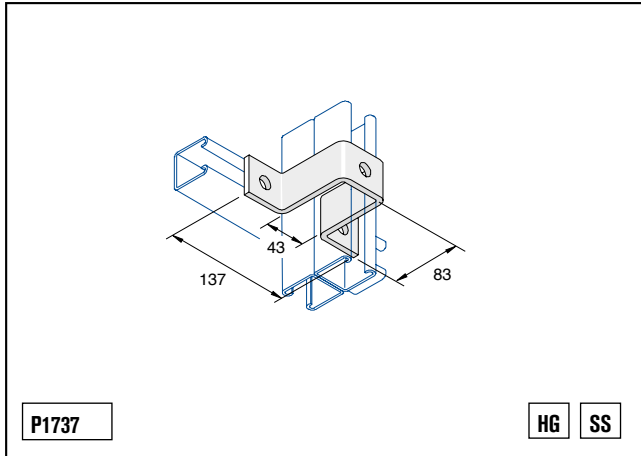

Finish		Weight	Box Qty	Stock	
HG	SS			HG	SS
HDP1737	I6P1737	0.58	10	✓	

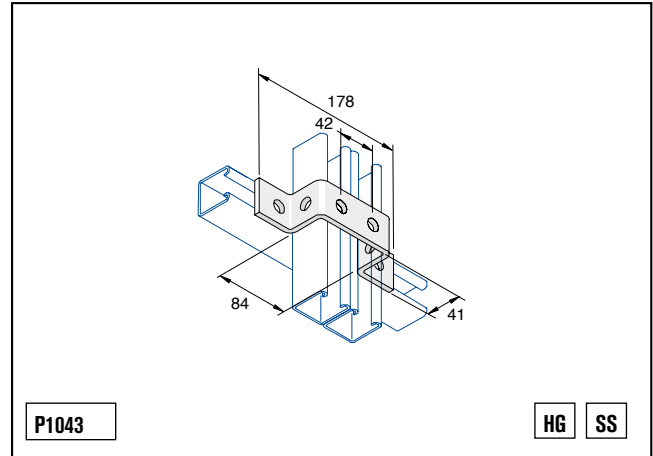

Finish		Weight	Box Qty	Stock	
HG	SS			HG	SS
HDP1043	I6P1043	0.48	20		

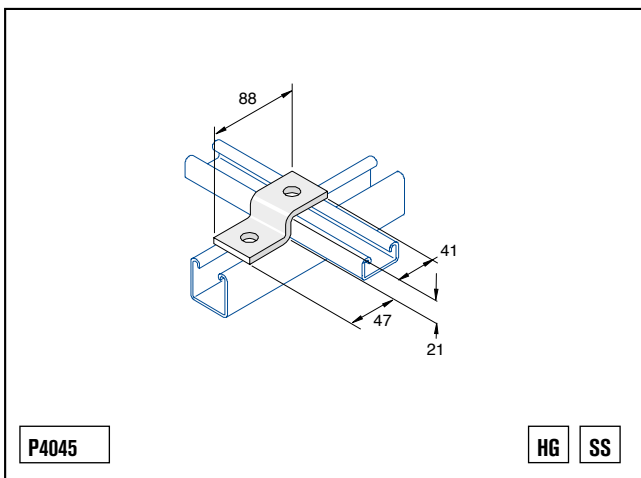

Finish		Weight	Box Qty	Stock	
HG	SS			HG	SS
HDP4045	I6P4045	0.21	50	✓	

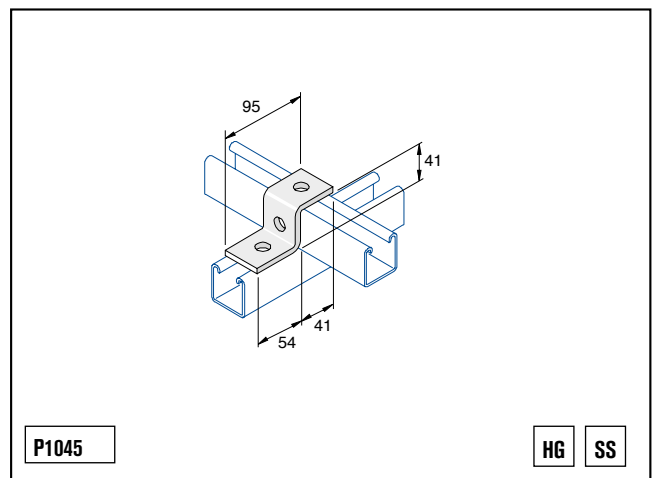

Finish		Weight	Box Qty	Stock	
HG	SS			HG	SS
HDP1045	I6P1045	0.25	25	✓	✓

U & Z Fittings & Channel Couplers

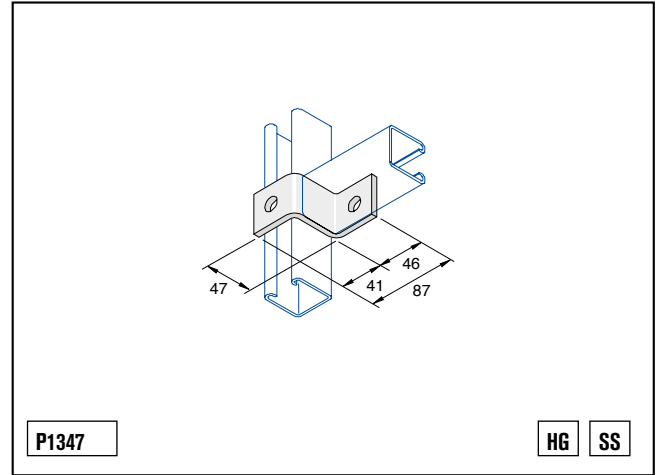
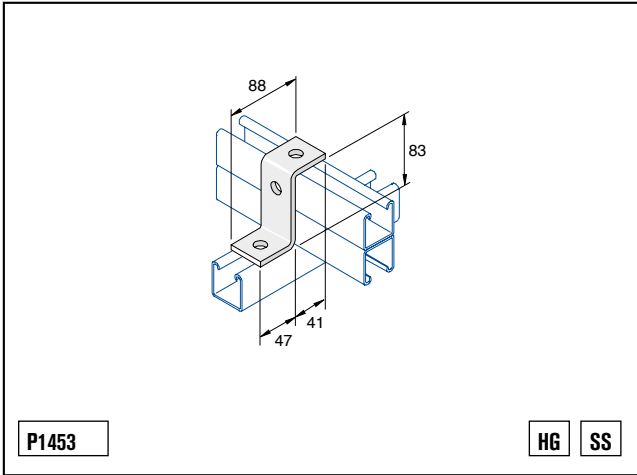

P1453	Finish		0.32	25	Stock	
	HG	SS			HG	SS
	HDP1453	I6P1453				

P1347	Finish		0.25	25	Stock	
	HG	SS			HG	SS
	HDP1347	I6P1347				✓

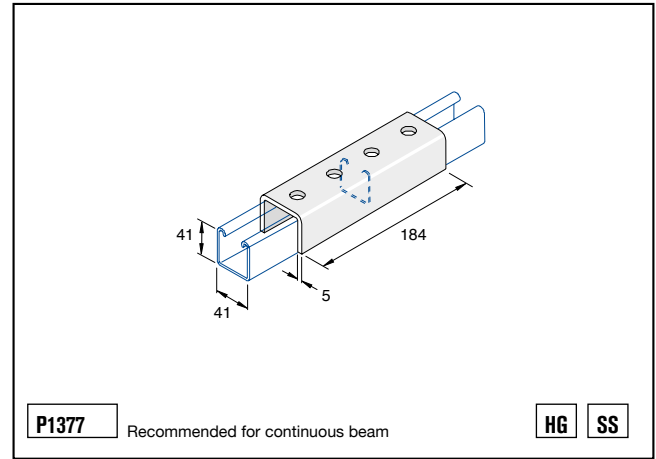
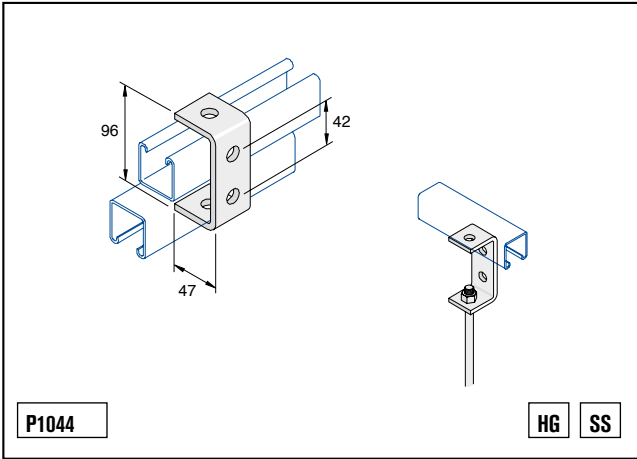

P1044	Finish		0.32	25	Stock	
	HG	SS			HG	SS
	HDP1044	I6P1044				✓

P1377	Finish		1.20	10	Stock	
	HG	SS			HG	SS
	HDP1377	I6P1377				✓

# Unistrut

## Beam Clamps

\* Used in pair

T= 22Nm  
M10

22mm Max.

75

5

3200 N

Loadings are per beam clamp and used in pairs.  
Mild steel u bolts are zinc plated.

**P2785 - P2787** **HG** **SS**

Finish		H (mm)	Hu (mm)	Weight	Stock
HG	SS				HG SS
HDP2785	I6P2785	21-41	86	0.31	25 ✓
HDP2786	I6P2786	62-83	127	0.35	25 ✓
HDP2787		124-164	209	0.43	25 ✓

P3087=P3087A + P3087B

A = 400mm Max

Dim A -23mm

2.7 kN

2.4 kN

T= 22Nm  
M10 x 40

Apply load in one direction only.  
Mild steel cone pointed screws are zinc plated.

**P3087** **HG** **SS**

Finish		Weight	Stock
HG	SS		HG SS
HDP3087	I6P3087	0.67	10 ✓

3

85

18

25

12

**Z10** **ZP**

Finish	Weight	Stock
ZP		
Z10U	0.06	100

T= 20 Nm  
M12 x 40

12

14

65

25

50

2700N

**P1983** **HG** **SS**

Finish		Weight	Stock
HG	SS		HG SS
HDP1983	I6P1983	0.39	10

11.5

3

46

**P1386-S1** **ZP**

Finish	Weight	Stock
ZP		
P1386-S1	0.05	20 ✓

\* Used in pair

13 mm max.

5

52

T= 70 Nm  
M12 x 40  
(not Incl.)

P1000: 1900 N  
P2000: 1900 N

**P1386** **HG** **SS**

Finish		Weight	Stock
HG	SS		HG SS
HDP1386	I6P1386	0.042	75 ✓

Stated loadings apply to mild steel products only.

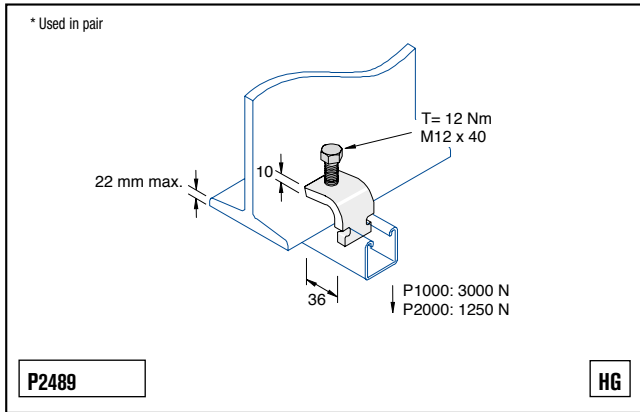

Finish		Weight	Quantity	Stock	
HG	SS			HG	SS
HDP2489		0.25	10	✓	

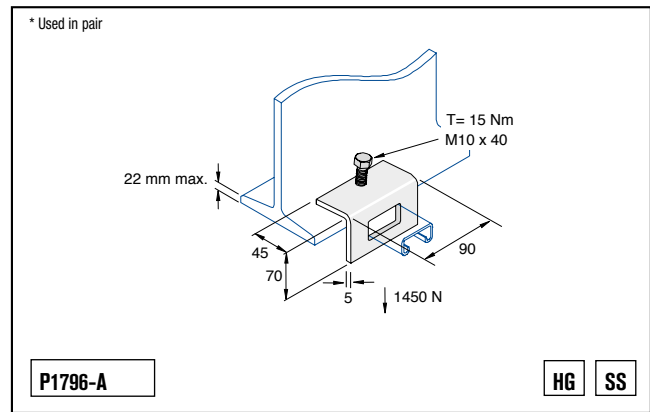

Finish		Weight	Quantity	Stock	
HG	SS			HG	SS
HDP1796-A	I6P1796-A	0.39	10	✓	

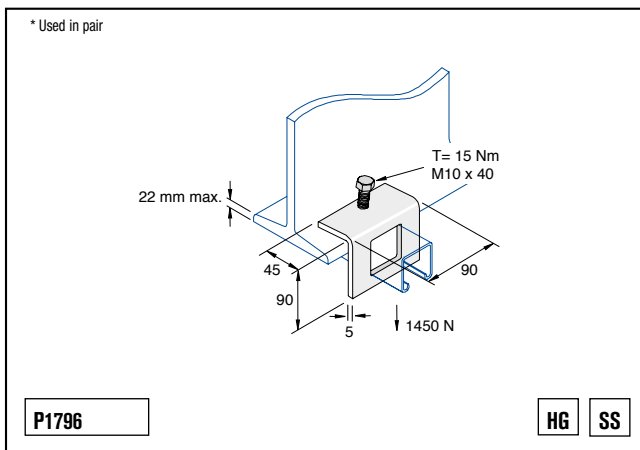

Finish		Weight	Quantity	Stock	
HG	SS			HG	SS
HDP1796	I6P1796	0.39	10	✓	

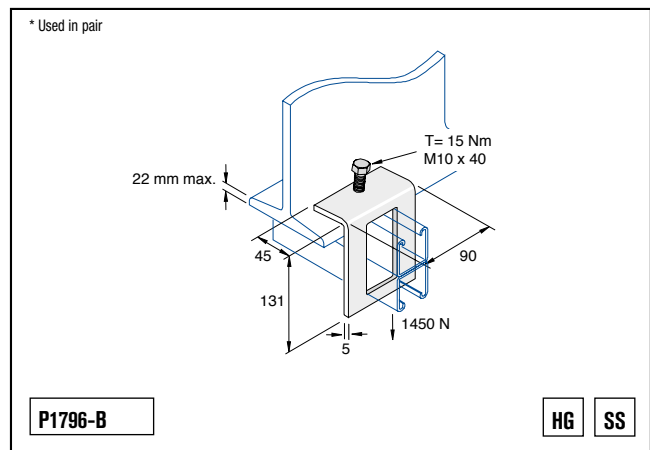

Finish		Weight	Quantity	Stock	
HG	SS			HG	SS
HDP1796-B	I6P1796-B	0.50	8	✓	

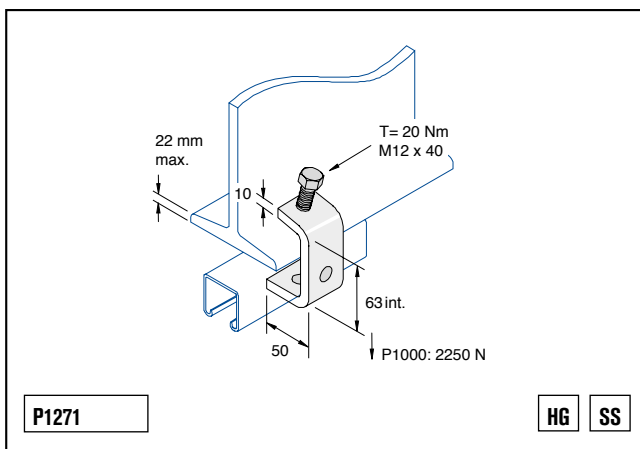

Finish		Weight	Quantity	Stock	
HG	SS			HG	SS
HDP1271	I6P1271	0.043	10	✓	

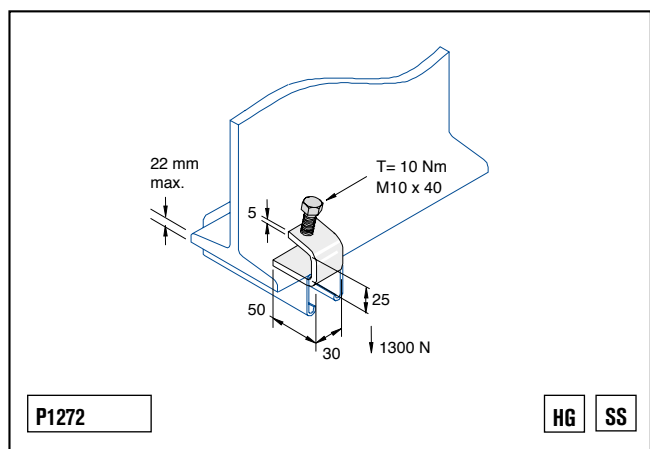

Finish		Weight	Quantity	Stock	
HG	SS			HG	SS
HDP1272	I6P1272	0.13	50	✓	✓

Stated loadings apply to mild steel products only.  
For thicker beam clamps, see Vergokan article HDVS41.46.

# Unistrut

## Channel Fittings

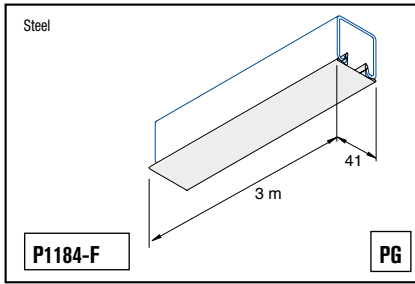

Part No.	Weight	Stock
P1184-F	1.07	1

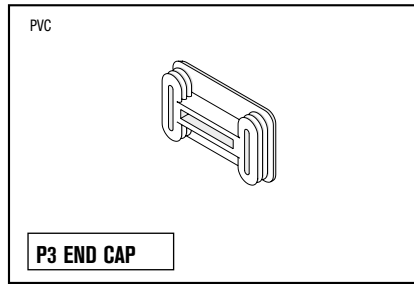

Part No.	Colour	Dimensions	Weight	Stock
139.21.98	Blue	41x21	0.3	100
139.21.96	White	41x21	0.3	100
139.21.97	Black	41x21	0.3	100

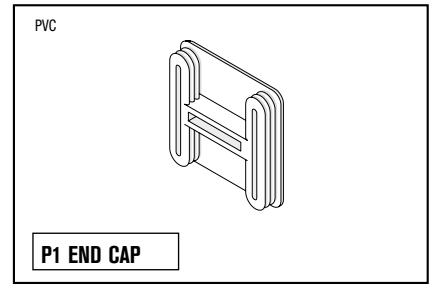

Part No.	Colour	Dimensions	Weight	Stock
139.41.98	Blue	41x41	0.5	100
139.41.96	White	41x41	0.5	100
139.41.97	Black	41x41	0.5	100

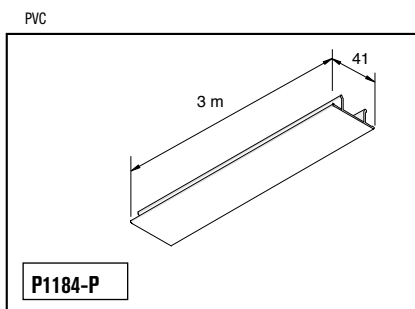

Part No.	Colour	Weight	Stock
P1184-PW	White	0.48	1
P1184-PB	Black	0.48	1

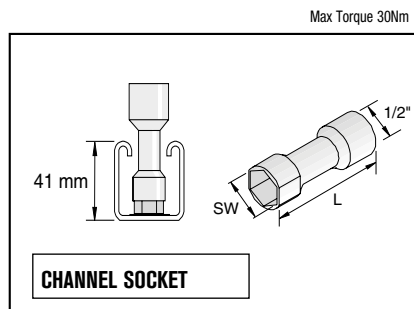

Part No.	Thread	Stock
17AF	M10	✓
19AF	M12	✓

## Channel Trolley Assemblies

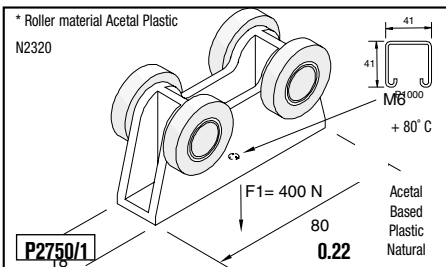

Part No.	Stock
P2750/1	✓

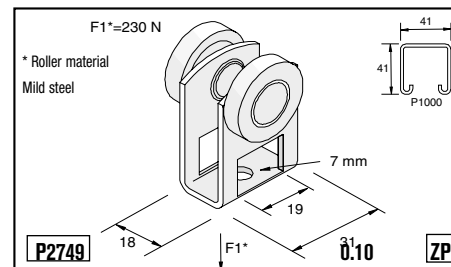

Part No.	Stock
P2749	✓

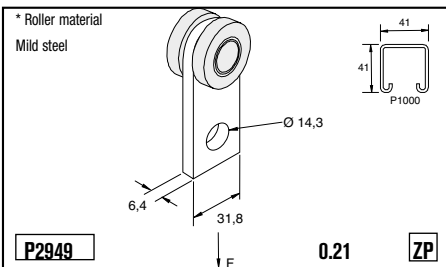

RPM	F (kN)
600	0.7
300	1.0
100	1.9

Part No.	Stock
P2949	✓

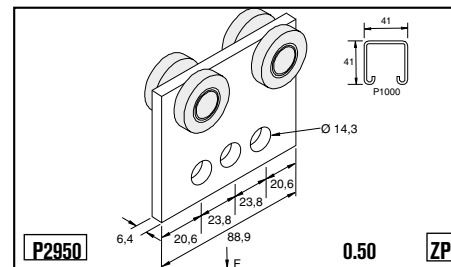

RPM	F (kN)
600	1.3
300	2.0
100	2.7

Part No.	Stock
P2950	✓

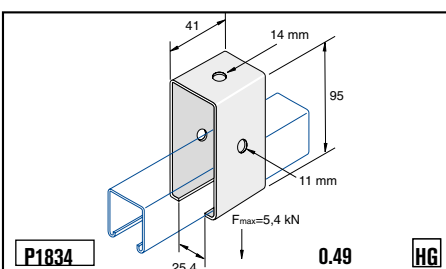

Part No.	Stock
HDP1843	✓

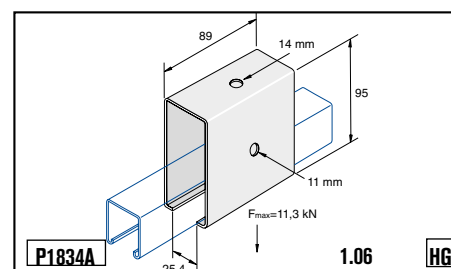

Part No.	Stock
HDP1834A	✓



Perforated Steel Band, Plastic Coated

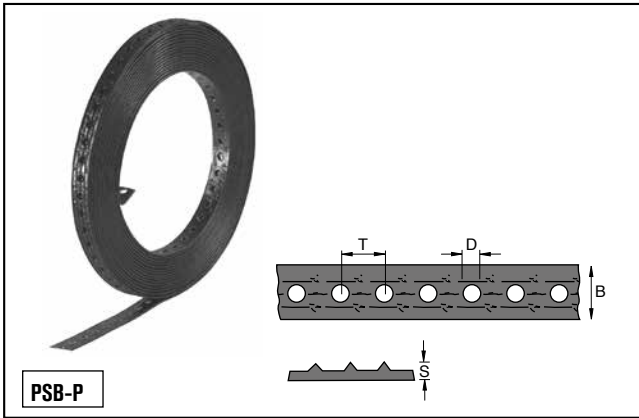

Part No.	B	D	T	S	F	m/			Stock
	mm	mm	mm	mm	N				
154.19.02	19	6.2	15	2.2	850	10	1.05	20	
154.27.02	27	8.2	25	3.0	1500	10	1.99	16	

Perforated Steel Band

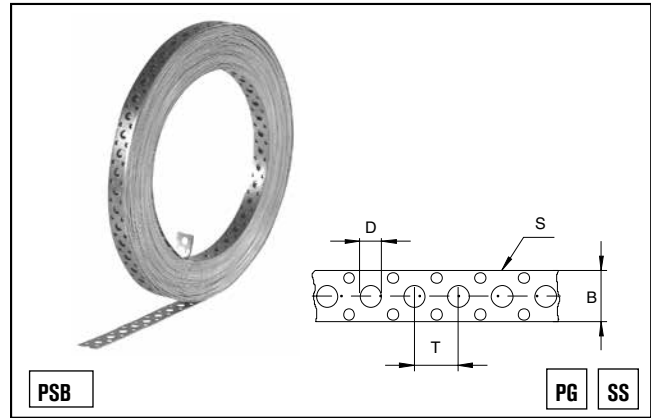

Finish	B	D	T	S	F	m/			Stock
PG SS	mm	mm	mm	mm	N				
155.17.02	17	6.5	15	0.8	850	25	2.25	8	
155.25.02	25	8.5	25	1.0	1500	10	1.66	16	
16135.17.02	17	6.5	15	0.8	850	10	0.60	10	

Finish [SS]: stainless steel DIN 14016; ASTM 430; BS 430S17

Toggle Clamp for Hollow Ceilings

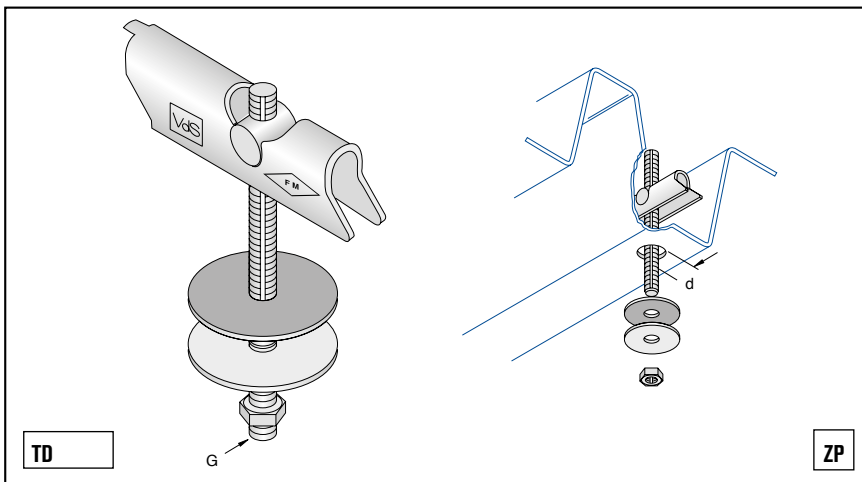

Finish	G	d			Approval	Stock
ZP	mm	mm				
TDM6x85	M6x85	15	0.05	100	-	
TDM8x100	M8x100	22	0.11	100	VdS	
TDM8x200	M8x200	22	0.14	100	VdS	
TDM8x300	M8x300	22	0.16	50	VdS	
TDM8x500	M8x500	22	0.24	50	VdS	
TDM10x100	M10x100	25	0.13	50	VdS	FM
TDM10x200	M10x200	25	0.18	50	VdS	FM

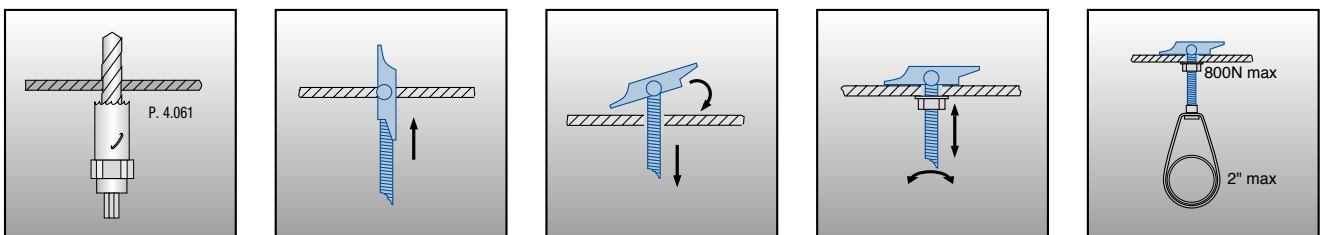

# Unistrut

## Deck and Purlin Fixings

### WARD MULTIDECK 60

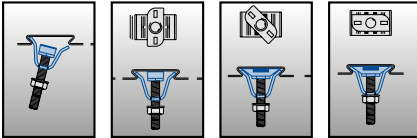
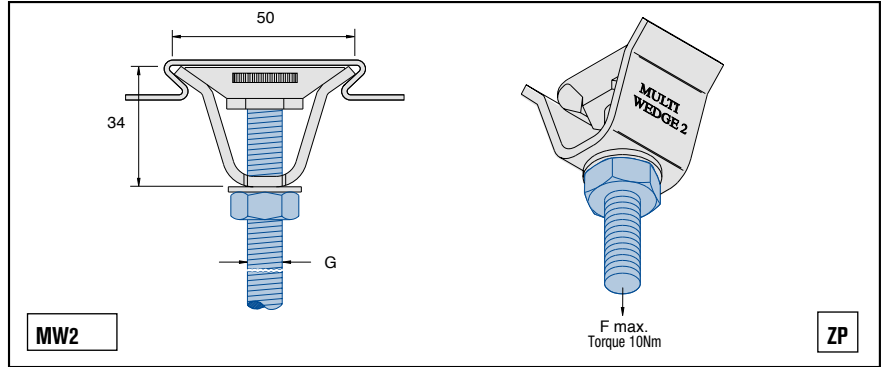
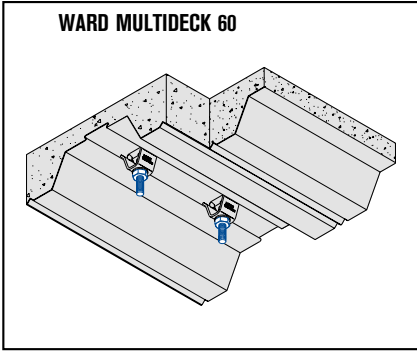

Finish	G	Fmax kN			Stock
ZP					
MW06	M6	1.47	0.10	50	
MW08	M8	1.47	0.10	50	
MW10	M10	1.47	0.10	50	

### HOLORIB

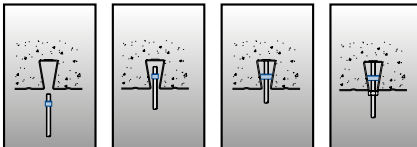
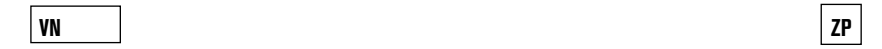
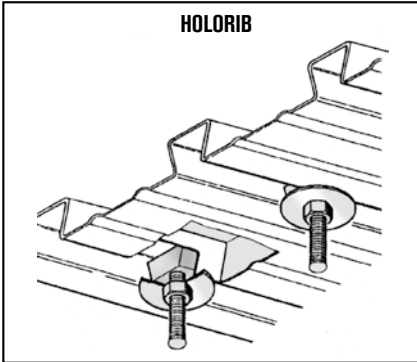

Finish	G	Fmax kN			Stock
ZP					
VN04	M4	0.86	0.02	500	
VN05	M5	1.4	0.02	500	
VN05	M6	1.8	0.02	500	
VN08	M8	2.0	0.02	500	
VN10	M10	2.1	0.02	500	

Loads quoted are subject to the strength of the supporting decking. Suitable for decking with a 15° tapered slot.

# 4. Pipe clamps

Original Unistrut® pipe clamps

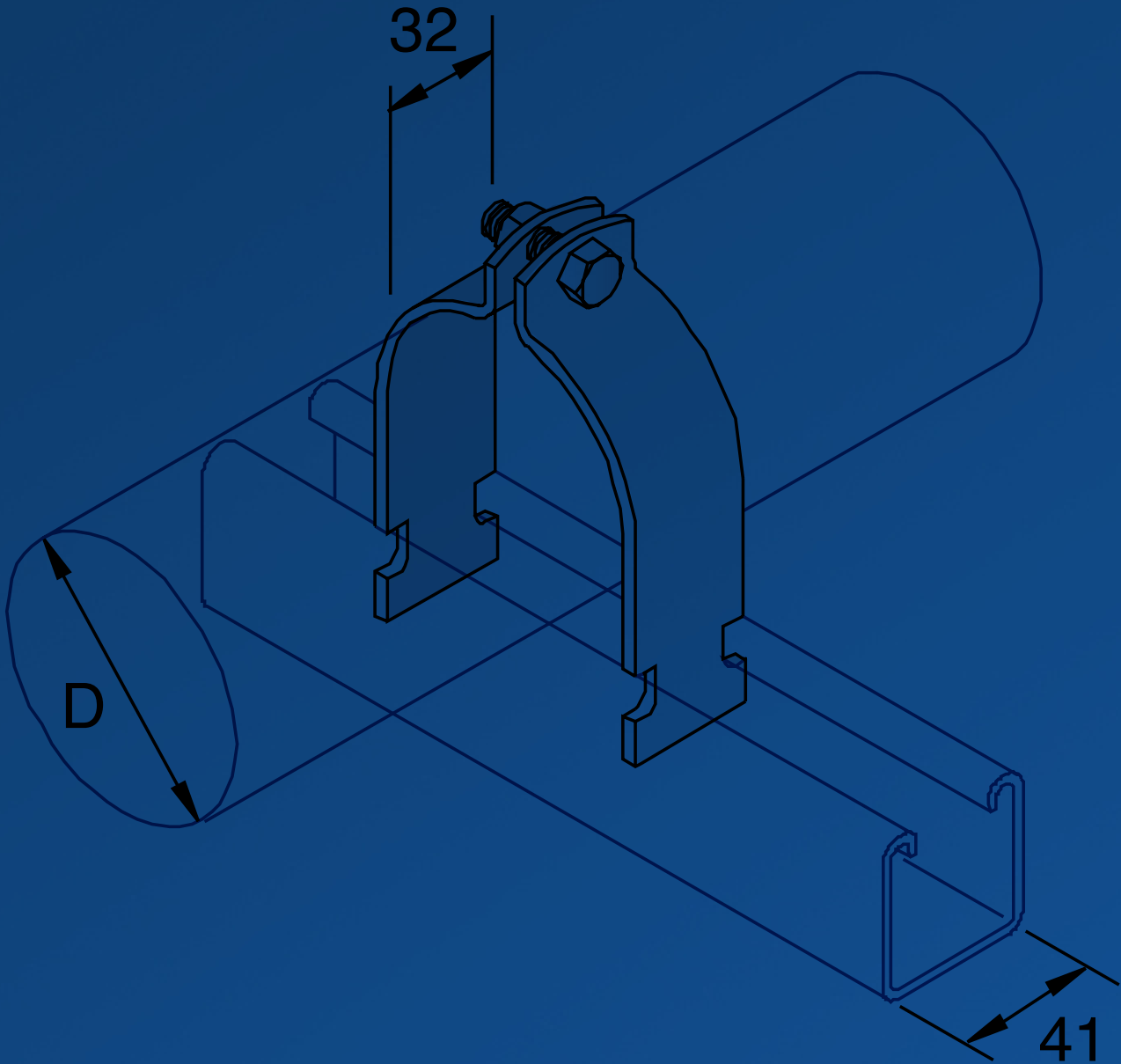

**VERGOKAN**  
**UNISTRUT®**

# Pipe Clamps

## Pipe Clamps for Unistrut Channels

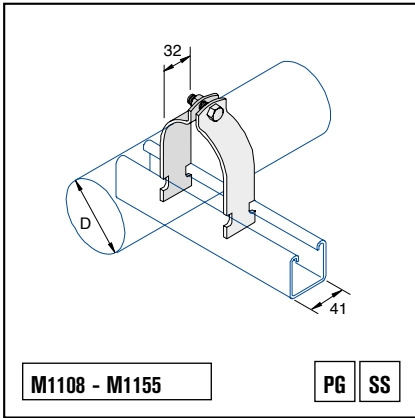

Finish		D mm	📏	📦	Stock	
PG	SS				PG	SS
M1108	I6M1108	8.7 - 10.3	35	150		
M1109	I6M1109	10.3 - 12.7	37	150		
M1110	I6M1110	11.9 - 13.5	38	150		
M1111	I6M1111	13.5 - 14.3	39	150		
M1112	I6M1112	14.3 - 16.7	40	150		
M1113	I6M1113	15.9 - 18.3	41	150	✓	
M1114	I6M1114	18.3 - 20.6	45	150		
M1115	I6M1115	19.0 - 21.4	47	150		
M1116	I6M1116	21.4 - 25.4	49	100	✓	
M1117	I6M1117	25.4 - 27.8	53	100	✓	
M1118	I6M1118	27.0 - 30.2	64	100	✓	
M1119	I6M1119	30.2 - 33.8	72	100	✓	
M1120	I6M1120	31.8 - 35.9	72	100	✓	
M1121	I6M1121	34.9 - 39.7	79	100	✓	
M1122	I6M1122	39.7 - 42.9	84	100	✓	
M1123	I6M1123	42.9 - 46.8	90	100		
M1124	I6M1124	46.8 - 50.8	128	50	✓	
M1125	I6M1125	48.4 - 52.4	131	50	✓	
M1126	I6M1126	52.4 - 58.7	137	50		
M1127	I6M1127	58.7 - 63.5	150	50	✓	
M1128	I6M1128	63.5 - 68.3	160	50		
M1129	I6M1129	68.3 - 73.0	164	50		
M1130	I6M1130	73.0 - 79.4	171	50	✓	
M1131	I6M1131	76.2 - 82.6	175	50		

Finish		D mm	📏	📦	Stock	
PG	SS				PG	SS
M1132	I6M1132	82.6 - 88.1	35	150		
M1133	I6M1133	88.1 - 95.2	37	150	✓	
M1134	I6M1134	95.2 - 100.0	38	150		
M1135	I6M1135	100.0 - 106.4	39	150		
M1136	I6M1136	106.4 - 111.1	40	150		
M1137	I6M1137	111.1 - 120.7	41	150	✓	
M1138	I6M1138	120.7 - 129.4	45	150		
M1139	I6M1139	129.4 - 138.1	47	150		
M1140	I6M1140	138.1 - 149.2	49	100		
M1141	I6M1141	149.2 - 161.9	53	100		
M1142	I6M1142	161.9 - 174.6	64	100	✓	
M1143	I6M1143	174.6 - 182.6	72	100		
M1144	I6M1144	182.6 - 190.5	72	100		
M1145	I6M1145	190.5 - 203.2	79	100		
M1146	I6M1146	203.2 - 212.7	84	100		
M1147	I6M1147	212.7 - 225.4	90	100		
M1148	I6M1148	225.4 - 238.1	128	50		
M1149	I6M1149	238.1 - 250.8	131	50		
M1150	I6M1150	250.8 - 263.5	137	50		
M1151	I6M1151	263.5 - 276.2	150	50		
M1152	I6M1152	275.2 - 288.9	160	50		
M1153	I6M1153	288.9 - 301.6	164	50		
M1154	I6M1154	301.6 - 314.3	171	50		
M1155	I6M1155	314.3 - 327.0	175	50		

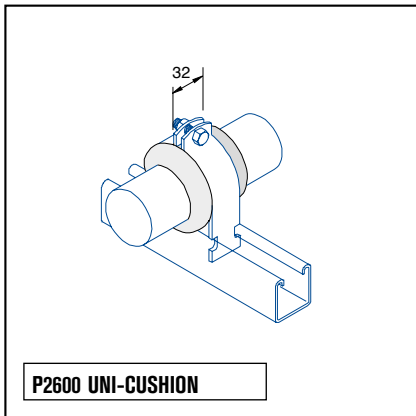

Part No.	Size mm	T mm	L m	📏 kg	Stock
P2600	32	1.5	8	1.02	✓

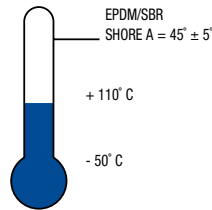

EPDM insulation for M11 and SS2 series clamps

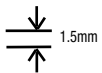

# VERGOKAN UNISTRUT®

## Vergokan nv

Meersbloem-Melden 16  
9700 Oudenaarde  
Belgium  
T: +32 55 31 83 35  
sales@vergokan.com  
export@vergokan.com  
www.vergokan.com



**RACEWAY. YOUR WAY.™**

A PART OF **atkore**  
INTERNATIONAL