

Vickers®

Vane Motors



MHT Vane Motors

High Torque, Low Speed
Single Torque, Multi-Torque

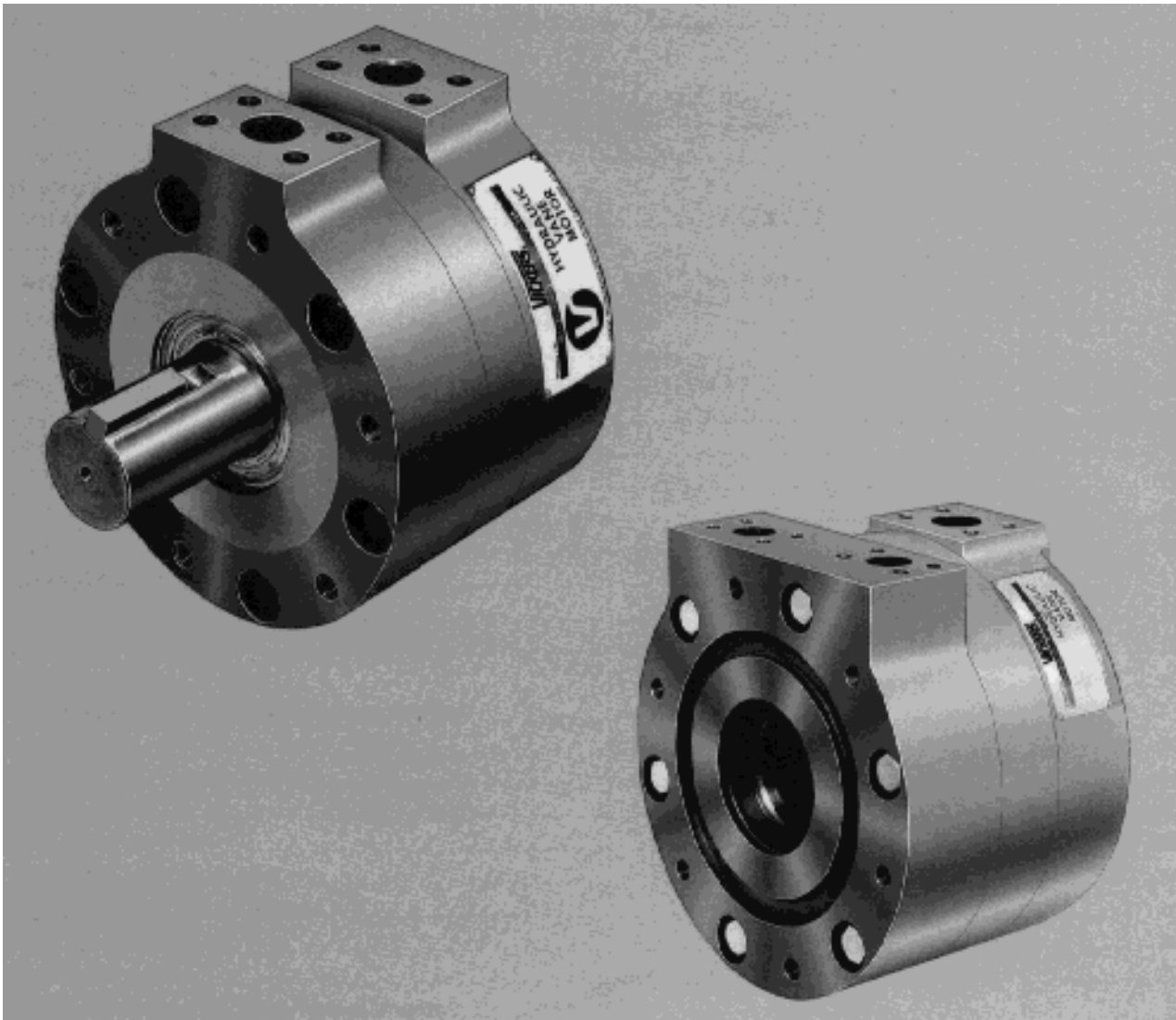

Introduction

Vickers MHT vane motors are the efficient, economical answer to a wide range of power needs. These high-quality motors are the ideal choice when:

- the combination of high torque and low speed is required
- a high power-to-weight/size ratio is required
- hazardous conditions or other design factors make it desirable that the electrical prime power source be located some distance away from the machinery driving motor.

Applications

MHT motors can be used in a wide variety of industrial and mobile applications, for example:

- Continuous casting machines
- Straightener drives
- Wheel rim rolling machines
- Forging manipulators
- Winding machine drives
- Sheet line accumulator systems
- Pre-plasticizer drives
- Machine tool spindle drives
- Coil winders
- Conveyors
- Feeder screws
- Rolling mill screwdown drives
- Drilling, boring machines
- Crushers

Features and Benefits

- Available in shaft-type or shaftless. Shaftless MHT motors can simplify installations, since the driven machine's splined shaft can be driven directly by the motor. Shaft-to-shaft couplings are thereby eliminated.
- MHT motors provide variable power throughout their entire pressure and speed range, and perform smoothly and efficiently in either direction of rotation.
- Shaftless MHT motors permit cooling water to be run through a hollow driving shaft, for example, driving plastic injection molding and extruder screws.
- Long operating life
- Stepless, infinitely variable speed control.
- Quick shaft reversing by reversing fluid flow.

Standard Motors

Vickers standard MHT motors are ideal for rotary power applications requiring high torque at low speed. They provide variable power throughout their entire pressure and speed range, and perform efficiently and smoothly in either direction of rotation.

Because these motors can eliminate the need for gear boxes or other external speed reducing devices, they offer the added advantage of compactness.

Multi-Torque Series

The Vickers multi-torque MHT motor is similar to the standard MHT motor in application and performance benefits, with one major difference – the design of the multi-torque motor permits choosing a number of different speed and torque combinations for any given flow and pressure.

For example, under conditions where maximum torque is not required, top motor speed can be achieved using the partial torque circuit shown. Conversely, maximum torque could also be achieved at less than maximum motor speed, using the full torque circuit shown.

This versatility permits substantial savings in pump size and costs for many applications without sacrificing necessary torque or speed characteristics.

- MHT multi-torque motors offer the ability to change the torque-to-speed ratios without requiring gear shifting mechanisms.

Contents

Ratings	2
Single Torque, Single Displacement Models	2
Multi-Torque, Multi-Displacement Models	3
Model Code	4
Installation Data	5
Mounting Information	5
Circuit	6
Shaft Information	7
Application Data	8
Start-up Procedure	8
Functional Symbols	8
Rotation	9
Bearing Capacity	9
Inertia of Rotating Group	9
Performance Data	11
MHT32	11
MHT50	11
MHT70 and MHT90	12
MHT130 and MHT150	12
MHT150	13
MHT250	14
MHT500	15
MHT750	16
MHT1000	16
MHT90/45/45	17
MHT380/190/190	18
MHT440/250/190	18
MHT500/250/250	19
Installation Dimensions – Single Torque Models	
MHT 32	20
MHT 50	21
MHT 70 & MHT 90	22
MHT 130 & MHT 150	23
MHT 190 & MHT 220 & MHT 250	24
MHT 380 & MHT 440 & MHT 500	25
MHT 750	26
MHT 1000	27
Installation Dimensions – Multi-Torque Models	
MHT 70/35/35 & MHT 90/45/45	28
MHT 130/75/75 & MHT 150/75/75	29
MHT 250/125/125 & 250/125/95 & 190/95/95	30
MHT 380/190/190 & 440/250/190 & 500/250/250	31
MHT 750/375/375	32
MHT 1000/500/500	33
Fluid Information	34

Ratings

Ratings – Single Torque, Single Displacement Models

Model & Theoretical Output Torque Nm/6,9 Δbar (lb. ft./100 Δpsi)	Theoretical Displacement cc ³ /rev (in ³ /rev)	Maximum Pressure bar (psi)		Maximum Speed (rpm) @ 138 Δbar (2000 Δpsi) and @ 207 Δbar (3000 Δpsi)	Weight (approximate)	
		Rated	Stalled		Shaftless	With Shaft
MHT32 43 (32)	393 (24)	207 (3000)	276 (4000)	400 275	48 (105)	54 (120)
MHT50 68 (50)	622,7 (38)	276 (4000)	276 (4000)	350 200	82 (180)	91 (200)
MHT70 95 (70)	865 (52.8)	207 (3000)	276 (4000)	300 150	95 (210)	109 (240)
MHT90 122 (90)	1113 (67.9)	207 (3000)	276 (4000)	300 150	95 (210)	109 (240)
MHT130 176 (130)	1606 (98)	207 (3000)	276 (4000)	250 150	142 (312)	162 (358)
MHT150 203 (150)	1852 (113)	207 (3000)	276 (4000)	250 150	142 (312)	162 (358)
MHT190 258 (190)	2360 (144)	138 (2000)	189,7 (2750)	150 —	200 (440)	236 (520)
MHT220 298 (220)	2720 (166)	138 (2000)	189,7 (2750)	150 —	200 (440)	236 (520)
MHT250 339 (250)	3081 (188)	138 (2000)	189,7 (2750)	150 —	200 (440)	236 (520)
MHT380 515 (380)	4719 (288)	138 (2000)	189,7 (2750)	150 —	281 (620)	327 (720)
MHT440 597 (440)	5440 (332)	138 (2000)	189,7 (2750)	150 —	281 (620)	327 (720)
MHT500 678 (500)	6194 (378)	138 (2000)	189,7 (2750)	150 —	281 (620)	327 (720)
MHT750 1017 (750)	9259 (575)	138 (2000)	189,7 (2750)	100 —	356 (784)	408 (900)
MHT1000 1356 (1000)	12356 (754)	138 (2000)	189,7 (2750)	100 —	436 (962)	508 (1120)

Case port pressure is 0–1.7 bar (0–25 psi) for all models

Ratings – Multi-Torque, Multi-Displacement Models

Model & Theoretical Output Torque Nm/6,9 Δbar (lb. ft./100 Δpsi)	Theoretical Displacement cc ³ /rev (in ³ /rev)	Maximum Pressure bar (psi)		Maximum Speed (rpm) @ 138 Δbar (2000 Δpsi) and @ 207 Δbar (3000 Δpsi)	Weight (approximate)	
		Rated	Stalled		Shaftless	With Shaft
MHT-70/35/35 95/48/48 (70/35/35)	865,4 & 432,7 (52.8 & 26.4)	207 (3000)	276 (4000)	300 150	95 (210)	109 (240)
MHT-90/45/45 122/61/61 (90/45/45)	1112,9 & 556,4 (67.9 & 33.9)	207 (3000)	276 (4000)	300 150	95 (210)	109 (240)
MHT-130/75/55 176/102/75 (130/75/55)	1605 & 1128 (98, 56,5 & 41.5)	207 (3000)	276 (4000)	250 150	142 (312)	162 (358)
MHT-150/75/75 203/102/102 (150/75/75)	1850,7 & 925,4 (113 & 56.5)	207 (3000)	276 (4000)	250 150	142 (312)	162 (358)
MHT-190/95/95 258/129/129 (190/95/95)	1179,2 & 2358,5 (72 & 144)	138 (2000)	190 (2750)	200 —	204 (450)	240 (530)
MHT-220/125/95 298/170/129 (220/125/95)	2718,7 & 1539,5 & 1179,2 (166 & 94 & 72)	138 (2000)	190 (2750)	200 —	204 (450)	240 (530)
MHT-250/125/125 339/170/170 (250/125/125)	3079,1 & 1539,5 (188 & 94)	138 (2000)	190 (2750)	200 —	204 (450)	240 (530)
MHT-380/190/190 515/258/258 (380/190/190)	4716,9 & 2358, 5 (287 & 143,5)	138 (2000)	190 (2750)	200 —	286 (630)	311 (730)
MHT-440/250/190 1056/339/258 (440/250/190)	5437,5 & 3079,1 & 2358,5 (332 & 188.5 & 145.5)	138 (2000)	190 (2750)	200 —	286 (630)	311 (730)
MHT-500/250/250 678/339/339 (500/250/250)	6158,2 & 3079,1 (376 & 188)	138 (2000)	190 (2750)	150 —	286 (630)	311 (730)
MHT-750/375/375 1017/508/508 (750/375/375)	9253,6 & 4635 (565 & 283)	138 (2000)	190 (2750)	100 —	360 (794)	412 (910)
MHT-1000/500/500 1356/678/678 (1000/500/500)	12356 & 6178 (754 & 377)	138 (2000)	190 (2750)	100 —	440 (972)	512 (1130)

Model Code

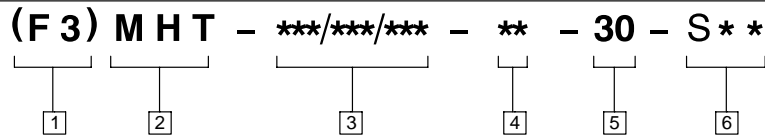

Standard Series Model Code

1 Special Seals

Omit if not required
 F3 – Seals for use with mineral oil and fire resistant fluids

2 Model Series

MHT – High torque, low speed, vane motor

3 Theoretical Output Torque per 100 psi differential Nm (lb. ft.)

Standard series

32 – 43 (32)
 50 – 68 (50)
 70 – 95 (70)
 90 – 122 (90)
 130 – 176 (130)
 150 – 203 (150)
 190 – 258 (190)
 220 – 298 (220)
 250 – 339 (250)
 380 – 515 (380)
 440 – 597 (440)
 500 – 678 (500)
 750 – 1017 (750)
 1000 – 1356 (1000)

4 Shaft type

R1 – Standard solid type
 N1 – No shaft

5 Design Number

Subject to change

6 Special Feature

Denoted special motor supplied with one bearing and no shaft (omit when not applicable). Install bearing on either side

S27 – Quiet version for MHT 130/150

Multi-torque Series Model Code

1 Special Seals

Omit if not required
 F3 – Special seals for use with mineral oil or fire resistant fluids

2 Model Series

MHT – High torque, low speed, vane motor

3 Theoretical Output Torque per 100 psi differential Nm (lb. ft.)

1000/500/500 –
 1356/678/678
 (1000/500/500)

750/375/375 –
 1017/508/508
 (750/375/375)

500/250/250 –
 678/339/339
 (500/250/250)

440/250/190 –
 678/339/258
 (5000/250/190)

Theoretical Output Torque (continued)

380/190/190 –
 515/258/258
 (380/190/190)

250/125/125 –
 339/170/170
 (250/125/125)

220/125/95
 298/170/129
 (220/125/95)

190/95/95
 258/129/129
 (190/95/95)

150/75/75
 203/102/102
 (150/75/75)

130/75/55
 176/102/75
 (130/75/55)

90/45/45
 122/61/61
 (90/45/45)

70/35/35
 95/48/48
 70/35/35

4 Shaft type

R1 – Standard solid type
 N1 – No shaft

5 Design Number

Subject to change

6 Special Feature

Denotes special motor.

S20 – Quiet version for MHT 130/220/380

S27 – Quiet version for MHT 130/150

S30 – Quiet version for MHT 500/750/1000

Installation Data

Mounting Information

This information points out areas of the motor where specific information is referenced. Refer to the respective "Installation Dimensions."

- The motor housing will accept no axial loading except at the following diameter bolt circles.

MHT Model	Bolt circle mm (inch)
32	203,2 (8.00)
50	250,8 (9.875)
70 90 70/35/35 90/45/45	266,7 (10.50)
130 150 130/75/75 150/75/75	298,5 (11.75)
190 220 250 380 440 500 750 1000 190/95/95 220/125/95 250/125/125 380/190/190 440/250/190 500/250/250 750/375/375 690/375/315 1000/500/500	342,9 (13.50)

- Mounting surface must be flat within 0.025 (0.001 in.) and perpendicular to the axis within 0.025 (0.001) TIR.
- The splined rotor will not accept any shaft translation, (sliding axially through spline).
- If the shaft must absorb axial forces, preloading will be required to prevent any translation. Consult your Vickers representative.

- If the application requires the mounting face to be sealed, an area has been provided for use with the following O-rings:

MHT Model	Vickers part number	I.D. O-ring mm (inch)
32	154112	158,34 (6.234)
50	192412	196,9 (7.75)
70 90 70/35/35 90/45/45	154120	215,9 (8.50)
130 150 130/75/75 150/75/75	199829	234,95 (9.25)
190 220 250 380 440 500 750 1000 190/95/95 220/125/95 250/125/125 380/190/190 440/250/190 500/250/250 750/375/375 690/375/315 1000/500/500	199838	279,4 (11.00)

- Motors may be supplied with the threads drilled out of the mounting surface body for through mounting with standard studs or screws, if required. Torque as shown in the following table:

Thru studs are not included. –S13 threads drilled from shaft end body; –S18 from head end body.

MHT Model	Torque Nm (lb. ft.)
32	122 ± 6 (90 ± 5)
50	169 ± 6 (125 ± 5)
70	
90	
70/35/35 90/45/45	
130 150 130/75/75 150/75/75	203 ± 20 (150 ± 15)
190	
220	
250	
380	
440	
500	
750	
1000	
190/95/95	
220/125/95	
250/125/125	
380/190/190	
440/250/190	
500/250/250	
750/375/375	
690/375/315	
1000/500/500	

- Conventional mounting is with six bolts through back of mounting plate, maximum length into motor and torque. Refer to the following table:

MHT model	Maximum length into motor mm (inch)	Torque Nm (lb. ft.)
32	44,45 (1.75)	81–95, (60–70)
50	44,45 (1.75)	81–95, (60–70)
70 90 70/35/35 90/45/45	31,75 (1.25)	81–95, (60–70)
70 90	44,45 (1.75)	81–95, (60–70)
130 150 130/75/75 150/75/75	38,1 (1.50)	81–95, (60–70)
190 220 250 380 440 500 750 1000 190/95/95 220/125/95 250/125/125 380/190/190 440/250/190 500/250/250 750/375/375 690/375/315 1000/500/500	38,1 (1.50)	81–95, (60–70)

- Motor mounting orientation is unrestricted as to port location and mounting face. The shaft may protrude from either body.
- Pilot must be a non-binding slip fit and must not exceed 5,84 mm (0.230) inch maximum into motor.

Suggested shaft seal size is according to the following table:

MHT model	Shaft seal size mm (inch)
50	64,26 (2.53)
70/35/35 90/45/45	69,85 (2.75)
130 150 130/75/75 150/75/75	79,5 (3.13)
190 220 250 380 440 500 750 1000 190/95/95 220/125/95 250/125/125 380/190/190 440/250/190 500/250/250 750/375/375 690/375/315 1000/500/500	104,78 (4.125)

Circuit

- Circuit design should protect the motor from pressure surges and cavitation.

CAUTION: CASE FLOW SHOULD BE UNRESTRICTED AND CHECKED TO ENSURE 1,89 lpm (0.05 USgpm) MINIMUM.

Case flow may be increased by applying back pressure to the motor return port. Operating the motor at a minimum pressure of 35 bar (500 psi) applied at the inlet port will provide the required case flow.

Thermal shocks in excess of 10° C (50° F) are not recommended. When the motor is cold or the oil is hot, start and stop motor until temperatures are equal.

Intermittent (15 minutes or less) unloaded running is permitted after a proper start and warm-up to 400 rpm, provided the minimum case flow is minimum case flow is maintained.

Shaft Information

- Shaft spline must slip fit into rotor.
- When disassembling or installing a shaft, there must be no binding or axial force applied.
- Shaft design must provide spline grease retention. The spline is not lubricated by system fluid. Customer shaft needs no shaft seal surface for system fluid retention.

- With a shaftless assembly, the customer will provide its own bearings and center the rotor with .004 TIR concentricity to the pilot diameters.
- The shaft spline should be packed with fibrous wheel-bearing grease at six month intervals, or sooner if operation is at high temperature. A standard 1/8 NPT grease fitting may be installed (not supplied) at the end of the shaft for this purpose.

A cover may be made to seal off shaftless models. The cover has a provision for a 1/8 NPT grease fitting. Use with O-ring 154094 and snap ring 380104 or equivalent.

If the installation uses no bearings in the motor, spline grease retention may be obtained by using a shaft seal adapter mounted in the bearing bore with an O-ring and snap ring.

Shaft Spline Data

millimeter (inch)

	MHT 32	MHT 50	MHT 70, 90	MHT 130,150	MHT 190, 220, 250	MHT 380, 440, 500, 750, 1000
Pitch Dia.	69,85 (2.7500)	76,20 (3.0000)	82,55 (3.2500)	101,6 (4.0000)	121,92(4.8000)	121,92 (4.8000)
Base Dia	60,492 (2.3816)	65,99 (2.5981)	71,5 (2.8146)	87,99 (3.4641)	105,58 (4.1569)	105,58 (4.1569)
No. of Teeth	44	48	39	40	48	48
Diametral Pitch	16/32	16/32	12/24	10/20	10/20	10/20
Press. Angle	30°	30°	30°	30°	30°	30°
Form Dia.	68,123 (2.6820)	74,460 (2.9315)	80,27 (3.1602)	98,86 (3.8920)	119,13 (4.6904)	119,13 (4.6904)
Major Diameter	71,438/71,311 (2.8125/2.8075)	77,788/77,661 (3.0625/3.0575)	84,66/84,54 (3.3333/3.3283)	104,14/104,01 (4.1000/4.0950)	124,46/124,33 (4.8950/4.9000)	124,46/124,33 (4.8950/4.9000)
Minor Diameter	66,675/66,396 (2.6250/2.6140)	73,035/72,746 (2.8750/2.8640)	78,740/78,400 (3.1000/3.0870)	97,028/96,647 (3.8200/3.8050)	117,348/116,967 (4.6200/4.6050)	117,348/116,967 (4.6200/4.6050)
Fillet Radii	0,508 (0.020)	0,508 (0.020)	0.8636 (0.034)	1,01 (0.040)	1,016 (0.040)	1,016 (0.040)
Circular Tooth Thickness	2,3927 (.0942) max. act. ref. 2,3571 (.0928) min. act. 2,4384 (.0960) max. eff. ref. 2,4028 (.0946) min. eff. ref.	2,395 (0.0943) max. act. ref. 2,360 (0.0929) min. act. 2,443 (0.0962) max. eff. 2,408 (0.0948) min. eff. ref.	3,20 (0.1262) max. act. ref. 3,16 (0.1247) min. act. 3,25 (0.1282) max. eff. 3,21 (0.1267) min. eff. ref.	3,87 (0.1523) max. act. ref. 3,83 (0.1508) min. act. 3,92 (0.1544) max. eff. 3,88 (0.1529) min. eff. ref.	3,85 (0.1517) max. act. ref. 3,81 (0.1501) min. act. 3,91 (0.1538) max. eff. 3,87 (0.1522) min. eff. ref.	3,85 (0.1517) max. act. ref. 3,81 (0.1501) min. act. 3,91 (0.1538) max. eff. 3,87 (0.1522) min. eff. ref.
Measurement over pins	3,048 (.1200) dia. pins: 74,4499 (2.9311) max. ref. 74,3915(2.9288) min. ref.	3,048 (.1200) dia. pins: 80,808 (3.1814) max. ref. 80,749 (3.1791) min. ref.	4,060 (0.1600) dia. pins: 88,63 (3.4895) max. ref. 88,57 (3.4870) min. ref.	4,876 (0.1920) dia. pins: 109,02 (4.2921) max. ref. 108,96 (4.2896) min. ref.	4,876 (0.1920) dia. pins: 129,33 (5.0916) max. ref. 129,26 (5.0890) min. ref.	4,876 (0.1920) dia. pins 129,33 (5.0916) max. ref. 129,26 (5.0890) min. ref.

Application Data

Start-Up Procedure

CAUTION: Failure to follow proper start-up procedures may damage the motor and system. Avoid dry shocks and thermal starts to prevent damage to the system or motor.

When an MHT motor is initially started, caution should be taken to ensure complete internal lubrication. The following will help ensure proper internal lubrication at start-up.

- Fill the unit with oil.
- Start split rise motors in full displacement.
- Set the speed control at 10 rpm or less.
- Jog the motor.
- Check for and maintain case drain flow while operating motor.
- Increase speed in low increments with load 35–69 bar (500–1000 psi) preferred.
- Warm the hydraulic system and the motor simultaneously.

Functional Symbols

Standard Motor

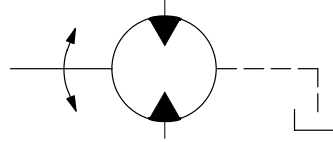

Multi-torque motors

Motor Installation possibilities for full and partial displacement and both directions of rotation

One Rotation

Full Displacement

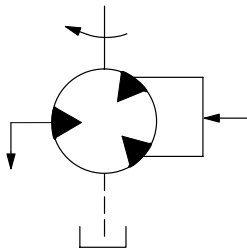

Partial Displacement

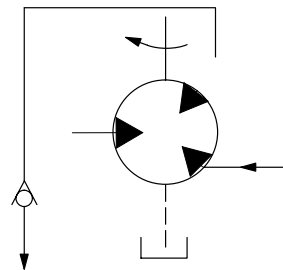

Opposite Rotation

Full Displacement

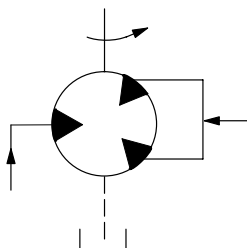

Partial Displacement

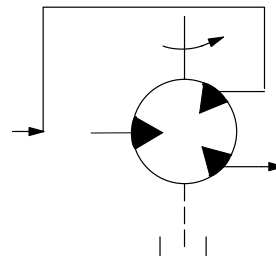

CAUTION: AVOID CIRCUITS WHERE ANY CONDITIONS COULD CAUSE INTENSIFIED PRESSURE. MULTI-DISPLACEMENT MOTORS CAN EXPERIENCED INTENSIFIED PRESSURES UNDER SOME CIRCUIT CONDITIONS SUCH THAT PRESSURES WILL EXCEED THE MOTOR, PIPING, OR VALVE RATING. SEE EXAMPLE BELOW.

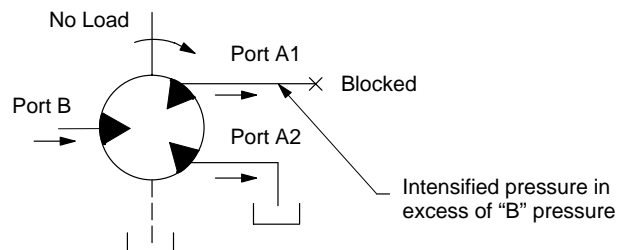

Rotation

MHT-32

Fluid to Port B gives clockwise rotation viewed from port A end, and fluid to port a gives counter-clockwise rotation.

All others

Fluid to Port A gives clockwise rotation, and fluid to port B gives counter-clockwise rotation.

Bearing Capacity

Model	Bearing Capacity N (lbf) AFBMA 33 1/3 rpm 500 hours, B-10 life	Bearing Capacity N (lbf) @ 50 rpm 15000 hours average life
MHT 32	22552 (5070)	10787 (2425)
MHT 50	23486 (5280)	11231 (2525)
MHT 70	29180 (6560)	13967 (3140)
MHT 90		17526 (3940)
MHT 130	36631 (8235)	26689 (6000)
MHT 150		
MHT 190		
MHT 220		
MHT 250		
MHT 380	55691 (12520)	
MHT 440		
MHT 500		
MHT 750		
MHT 1000		

Inertia of Rotating Group (approximate)

Model	Without Shaft		With Shaft	
	Nm ² (lb.-in ²)	Nm-sec ² (lb.-in-sec ²)	Nm ² (lb.-in ²)	kg-cm ² -sec ² (lb.-in-sec ²)
MHT 32	5,7 (50)	1.47 (13)	6,8 (60)	1,81 (16)
MHT 50	16,4 (145)	4.29 (38)	18,3 (162)	4,75 (42)
MHT 70	29,6 (262)	7.68 (68)	32,3 (286)	8,36 (74)
MHT 90				

MHT 130				
MHT 150	53,9 (477)	0,14 (1.24)	32,3 (548)	0,16 (1.42)
MHT 190				
MHT 220	106,2 (940)	0,28 (2.43)	124,3 (1100)	0,32 (2.85)
MHT 250				
MHT 380				
MHT 440	212,4 (1880)	0,55 (4.86)	239,2 (2117)	0,62 (5.47)
MHT 500				
MHT 750	318,6 (2820)	0,82 (7.29)	352,2 (3117)	0,91 (8.06)
MHT 1000	424,8 (3760)	1,10 (9.72)	464,9 (4115)	1,2 (10.65)

Performance Data

Typical performance in 10W oil at 49°C (120°F) and 137 bar (2000 psi)

MHT32

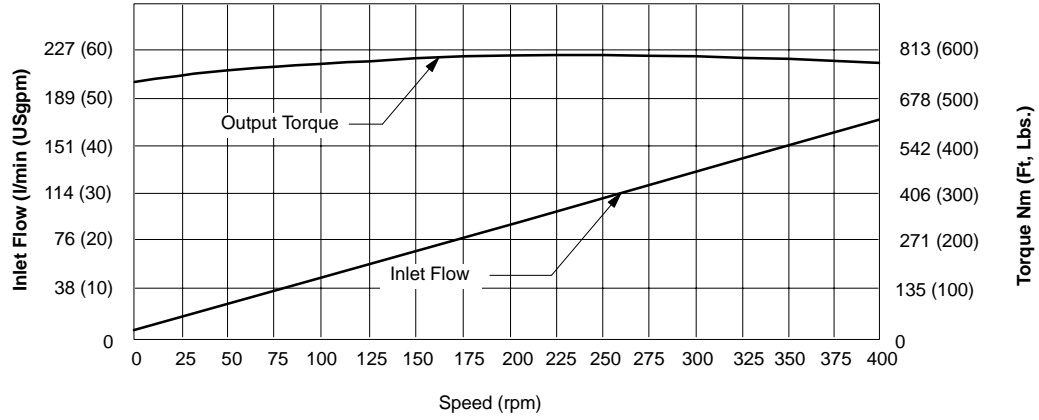

MHT50

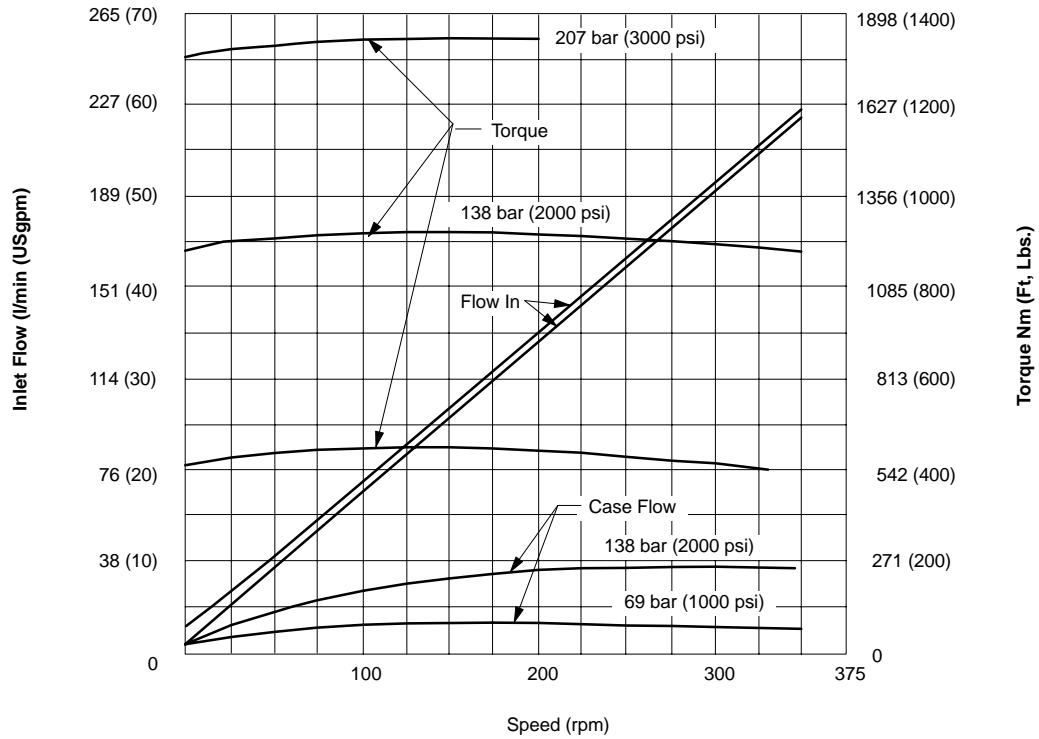

Typical performance in 10W oil at 49°C (120°F) and 137 bar (2000 psi)

**MHT70
&
MHT90**

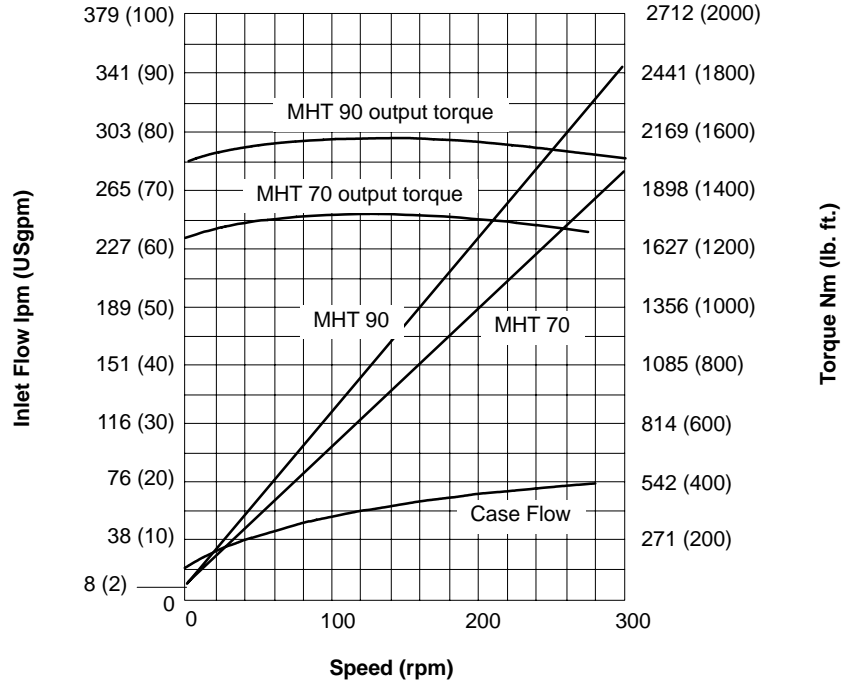

**MHT130
&
MHT150**

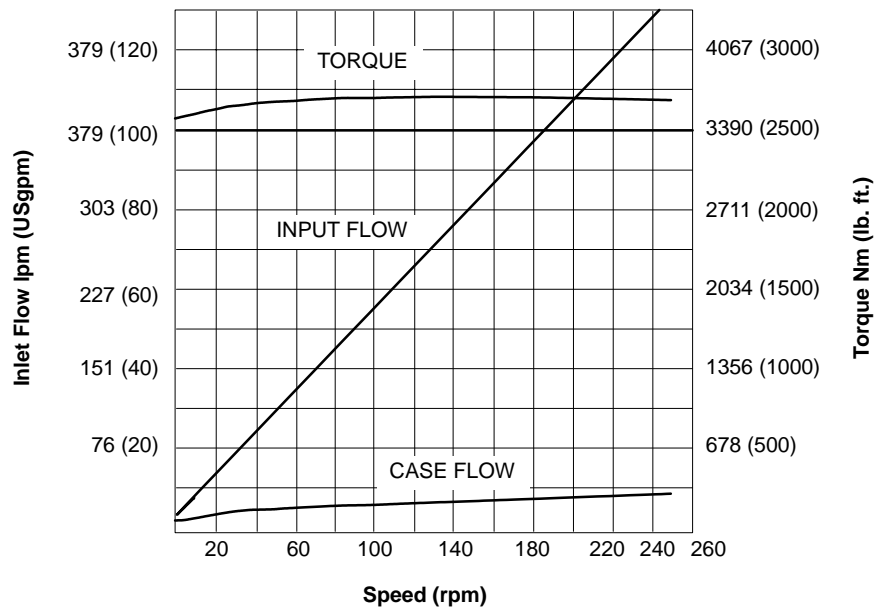

Using Performance Curves

The curves are typical for conventional MHT 150 motors. Factors are also provided for using the curves for multi-torque motors. Examples of both follow:

Full Displacement (150 mode)

Required: 130 rpm, 3796 Nm (2800 lb. ft.) torque using MHT 150-R1-30 motor and 180 SUS oil.

- Determine the operating pressure: Draw coordinated from the 3796 (2800 lb. ft.) point on the left vertical axis to connect to the 130 rpm speed on the horizontal axis at point "A." The operating differential pressure is 145 bar (2100 psi). Be sure to work between the pressure lines.
- Determine the input flow required: The point obtained from step one must be extended to the top of the curve by an imaginary new curve to obtain the 273 l/min (72 USgpm) flow.

Partial Displacement (130, 75 or 55 mode)

Required: 215 rpm, 1627 Nm (1200 lb. ft.) torque, using the reduced

displacement 75 mode of an MHT130/75/55 or MHT 150/75/75 motor with 180 SUS oil.

- Determine the operating pressure: Since the 75 mode will produce only 0.49 of the torque of the 150 mode, the operating differential pressure must be based on 1200 divided by 0.49. The torque factor shown below for this mode, or 3322 Nm (2450 lb. ft.) torque. This "new" torque figure is used to find the operating differential pressure from the curves. Again, connect the torque and speed coordinates to locate point "B." The operating differential pressure based on 3322 Nm (2450 lb. ft.) torque and 215 rpm speed is 124 bar (1800 psi) to produce 1627 Nm (1200 lb.ft.) in this mode.
- Determine the input flow required. Since the 75 mode displacement is 51% of the full displacement 150 mode, the input flow obtained from the curves for point "B" must be multiplied by .51 to obtain the input flow required. Extend an

imaginary curve to the top of the graph to read 427 l/min (113 USgpm). The actual flow required 113 x .51, or 220 l/min (58 USgpm)

Partial Displacement Factors

For use with split-rise, multi-torque motors as described in example 2 above.

Model Mode	Flow Factor	Torque Factor
150	1.00	1.00
130	.86	.86
75	.51	.49
55	.37	.36

Drain flow at 138 bar (2000 psi) may be as much as 8 l/min (2 USgpm) on some motors

NOTE: Due to manufacturing and viscosity variations, flow and torque values may vary from the typical data shown.

Typical performance in 180 SSU fluid @ 138 bar (2000) Δ psi

MHT-150

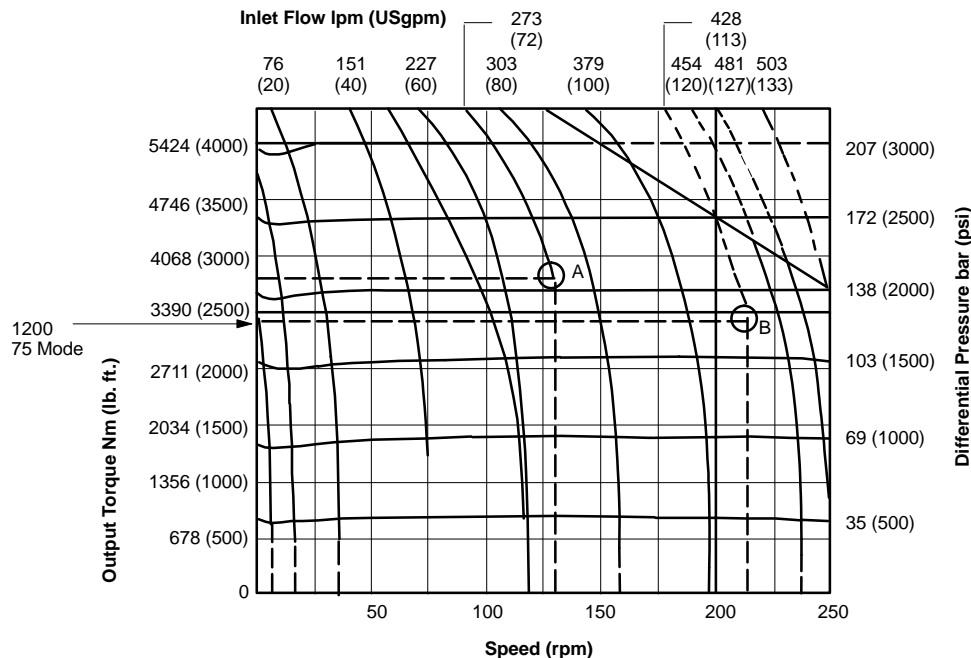

Using Performance Curves

The curves are typical for conventional MHT 250 motors. Factors are provided for using the curves for multi-torque motors. Examples of both follow:

Full displacement (250 mode)

Required: 110 rpm, 5085 Nm (3750 lb. ft.) torque using MHT 250-R1-30 motor and 180 SUS oil

1. Determine the operating pressure: Draw coordinated from the 5085 (3750 lb. ft.) point on the left vertical axis to connect to the 110 rpm speed on the horizontal axis at point "A." The operating differential pressure is 110 bar (1600 psi). Be sure to work between the pressure lines.
2. Determine the input flow required: The point obtained from step one must be extended to the top of the curve by an imaginary new curve to obtain the 356 l/min (94 USgpm) flow.

Partial Displacement (220, 190 or 125 modes)

Required: 160 rpm, 2373 Nm (1750 lb. ft.) torque, using the reduced

displacement 125 mode of an MHT250/125/125 or MHT 220/125/95 motor with 180 SUS oil

1. Determine the operating pressure: Since the 125 mode will produce only 0.48 of the torque of the 250 mode, the operating differential pressure must be based on 1750 divided by 0.48. The torque factor shown below for this mode, or 4943 Nm (3645 lb. ft.) torque. This "new" torque figure is used to find the operating differential pressure from the curves. Again, connect the torque and speed coordinates to locate point "B." The operating differential pressure based on 4943 Nm (3645 lb. ft.) torque and 160 rpm speed is 108 bar (1560 psi) to produce 2372 Nm (1750 lb. ft.) in this mode.
2. Determine the input flow required. Since the 125 mode displacement is 51% of the full displacement 250 mode, the input flow obtained from the curves for point "B" must be multiplied by .51 to obtain the input flow required. Extend an

imaginary curve to the top of the graph to read 511 l/min (135 USgpm). The actual flow required 135 x .51, or 260,7 l/min (68,9 USgpm)

Partial Displacement Factors

For use with split-rise, multi-torque motors as described in example 2 above.

Model Mode	Flow Factor	Torque Factor
250	1.00	1.00
220	.88	.84
190	.76	.71
125	.51	.46
95	.39	.36

Drain flow at 138 bar (2000 psi) may be as much as 8 l/min (2 USgpm) on some motors

NOTE: Due to manufacturing and viscosity variations, flow and torque values may vary from the typical data shown.

Typical performance in 180 SSU fluid @ 138 bar (2000) Δ psi

MHT-250

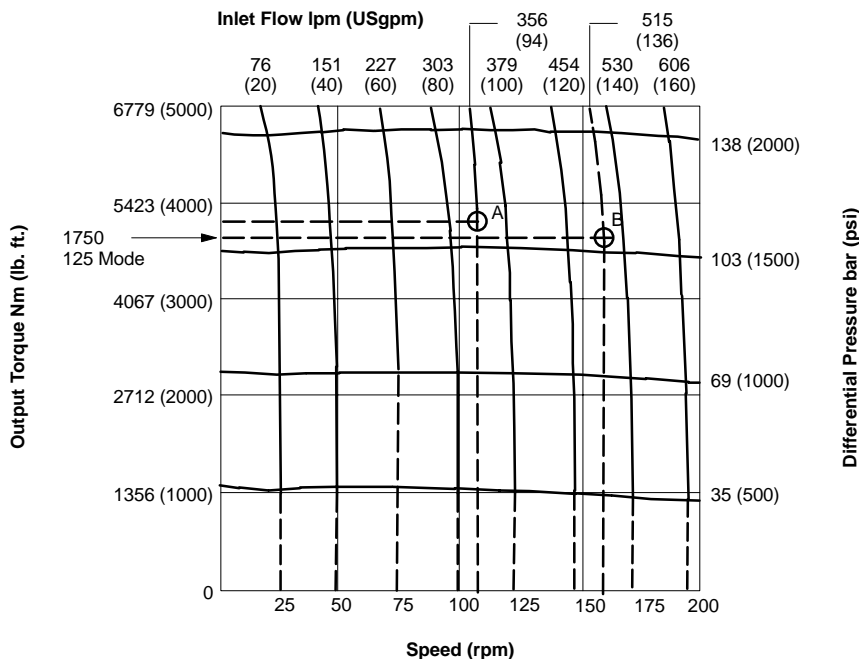

Using Performance Curves

The curves are typical for conventional MHT 500 motors. Factors are provided for using the curves for multi-torque motors. Examples of both follow:

Full displacement (500 mode)

Required: 90 rpm, 9830 Nm (7250 lb. ft.) torque using MHT 500-R1-30 motor and 180 SUS oil

1. Determine the operating pressure: Draw coordinated from the 9830 (7250 lb. ft.) point on the left vertical axis to connect to the 90 rpm speed on the horizontal axis at point "A." The operating differential pressure is 108 bar (1565 psi). Be sure to work between the pressure lines.
2. Determine the input flow required: The point obtained from step one must be extended to the top of the curve by an imaginary new curve to obtain the 582 l/min (154 USgpm) flow.

Partial Displacement (250 or 190 modes)

Required: 150 rpm, 3000 lb. ft. torque, using the reduced displacement 250

mode of an MHT 500/250/250 motor with 180 SUS oil

1. Determine the operating pressure: Since the 250 mode will produce only 0.48 of the torque of the 500 mode, the operating differential pressure must be based on 3000 divided by 0.48. The torque factor shown below for this mode, or 8475 Nm (6250 lb. ft.) torque. This "new" torque figure is used to find the operating differential pressure from the curves. Again, connect the torque and speed coordinates to locate point "B." The operating differential pressure based on 8475 Nm (6250 lb. ft.) torque and 150 rpm speed is 97 bar (1400 psi) to produce 4068 Nm (3000 Lb. Ft.) in this mode.
2. Determine the input flow required: Since the 250 mode displacement is 48% of the full displacement 500 mode, the input flow obtained from the curves for point "B" must be multiplied by .48 to obtain the gpm input flow required. Extend an

imaginary curve to the top of the graph to read 973 l/min (257 USgpm). The actual flow required is 257 x .48, or 469 l/min (124 USgpm).

Partial Displacement Factors

For use with split-rise, multi-torque motors as described in example 2 above.

Model	Flow Factor	Torque Factor
440	.88	.84
380	.76	.71
250	.48	.46
190	.36	.36

Drain flow at 138 bar (2000 psi) may be as much as 8 l/min (2 USgpm) on some motors

NOTE: Due to manufacturing and viscosity variations, flow and torque values may vary from the typical data shown.

Typical performance in 180 SSU fluid @ 138 bar (2000) Δ psi

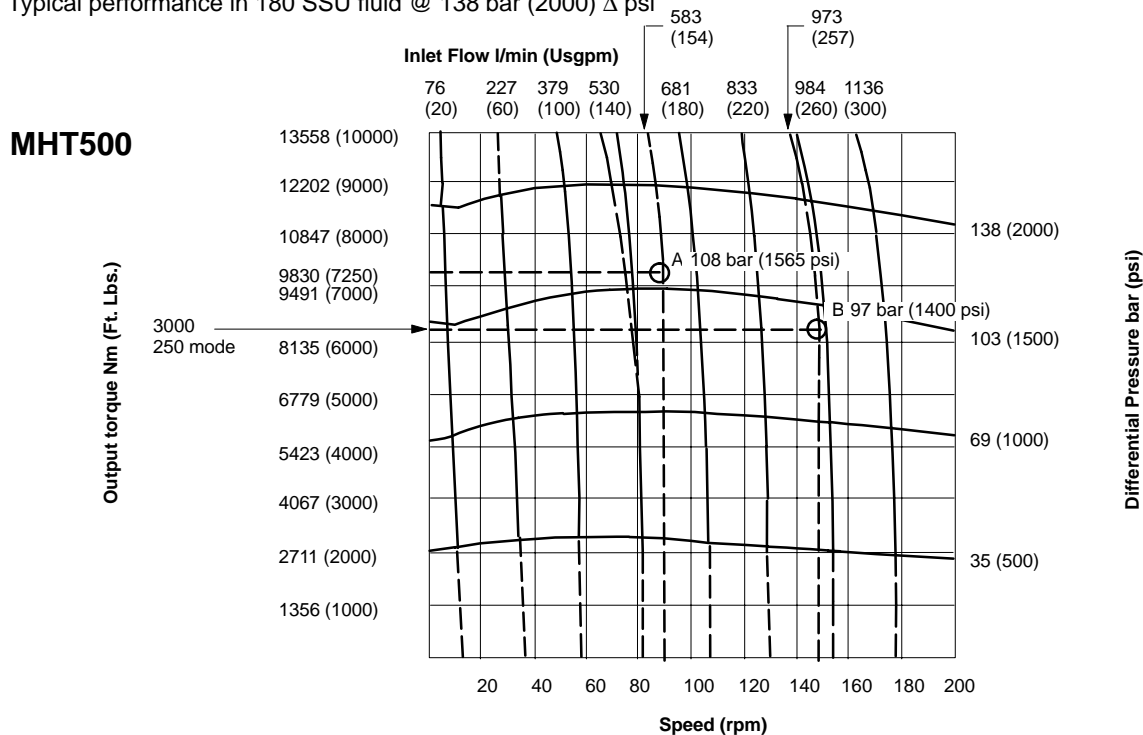

Typical performance in 180 SSU fluid
 Inlet pressure 103 Δbar (1500 Δpsi)
 Inlet temperature 49 °C (120°F)

MHT750

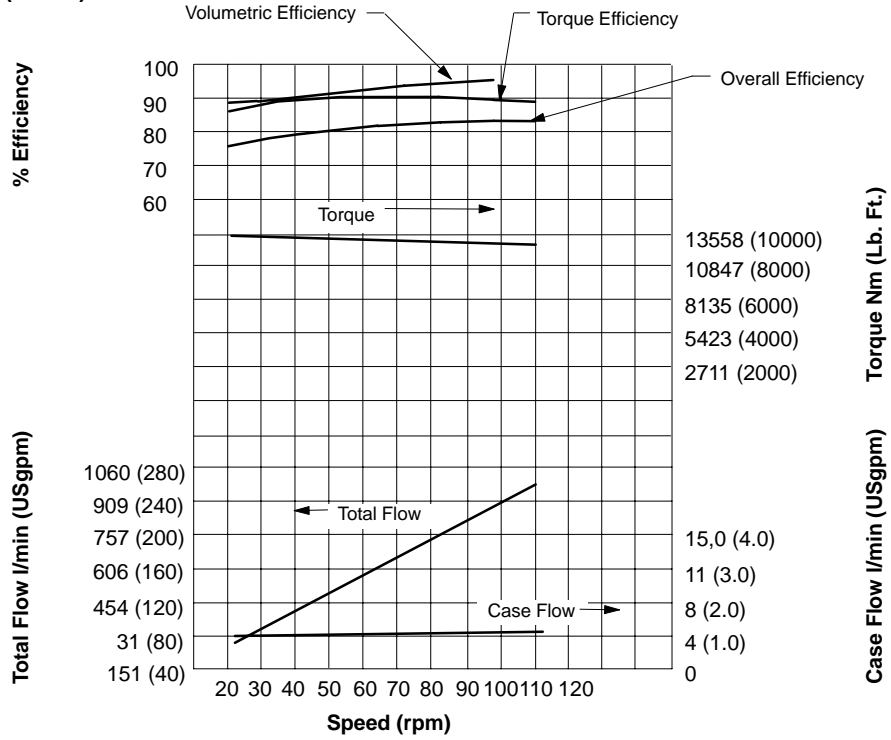

MHT-1000

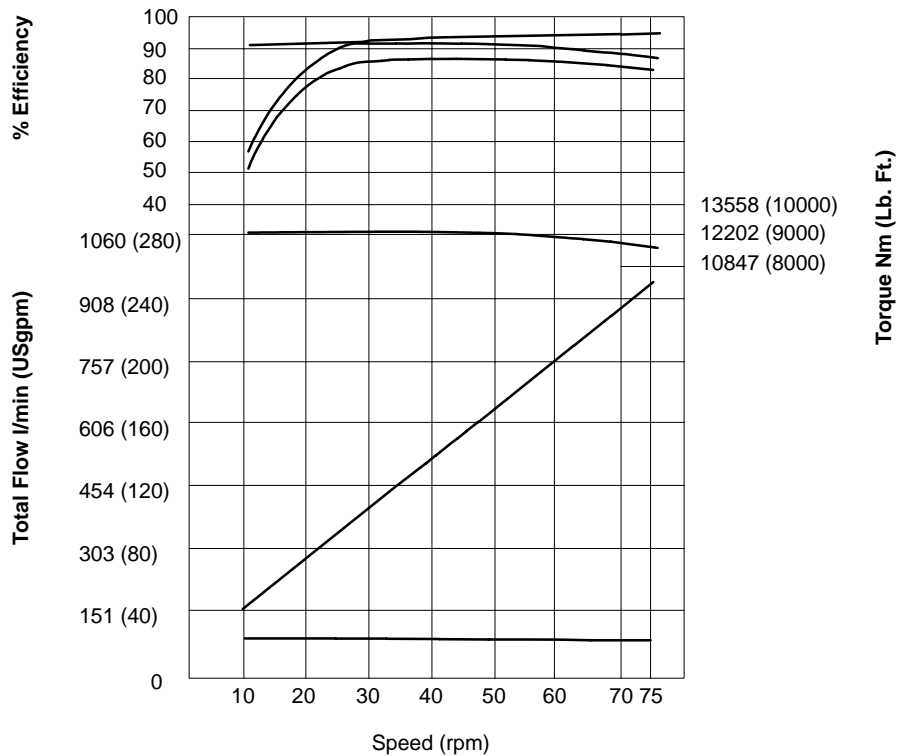

Typical full displacement performance in 180 SSU fluid @ 138 bar (2000) Δ psi

MHT 90/45/45

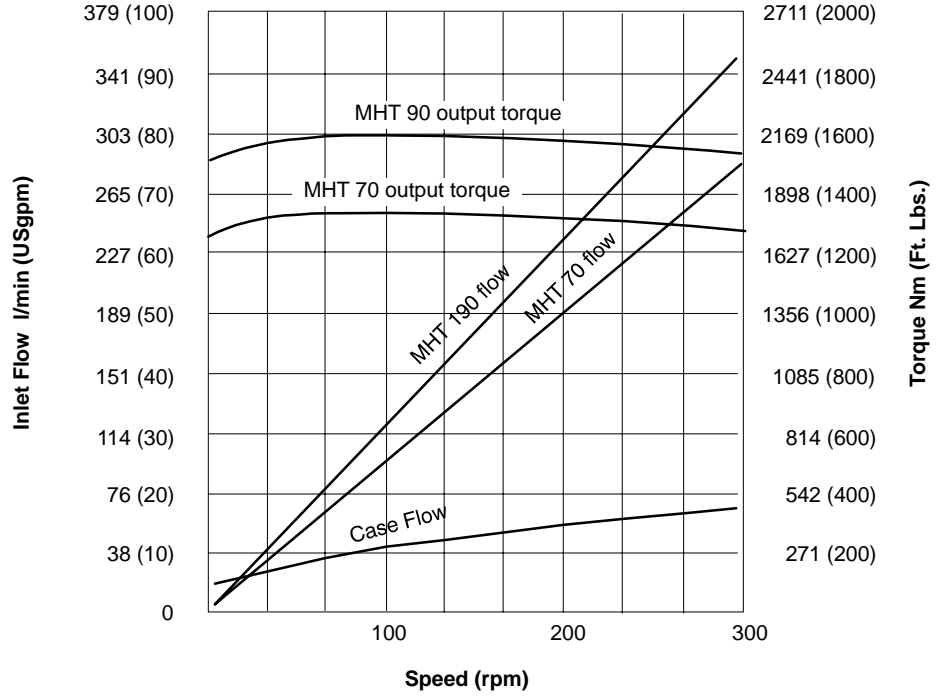

Typical half displacement performance in 180 SSU fluid @ 138 bar (2000) Δ psi

MHT 90/45/45

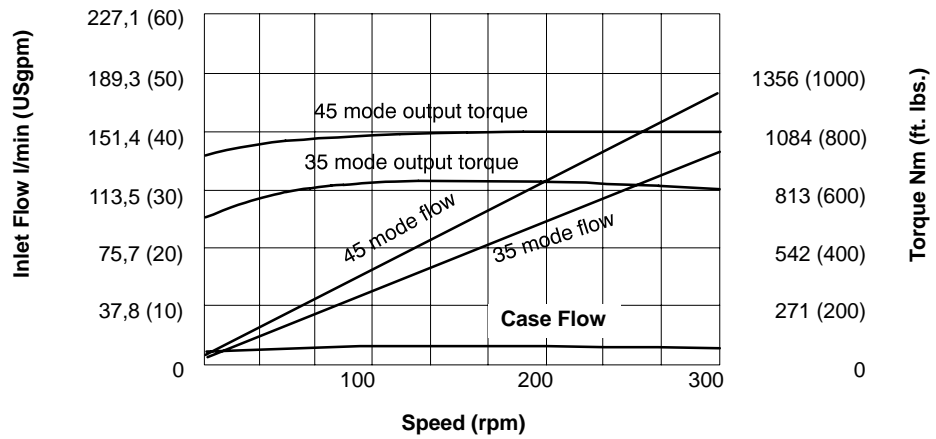

Typical half displacement performance in 180 SSU fluid @ 138 bar (2000) Δ psi

MHT 380/190/190

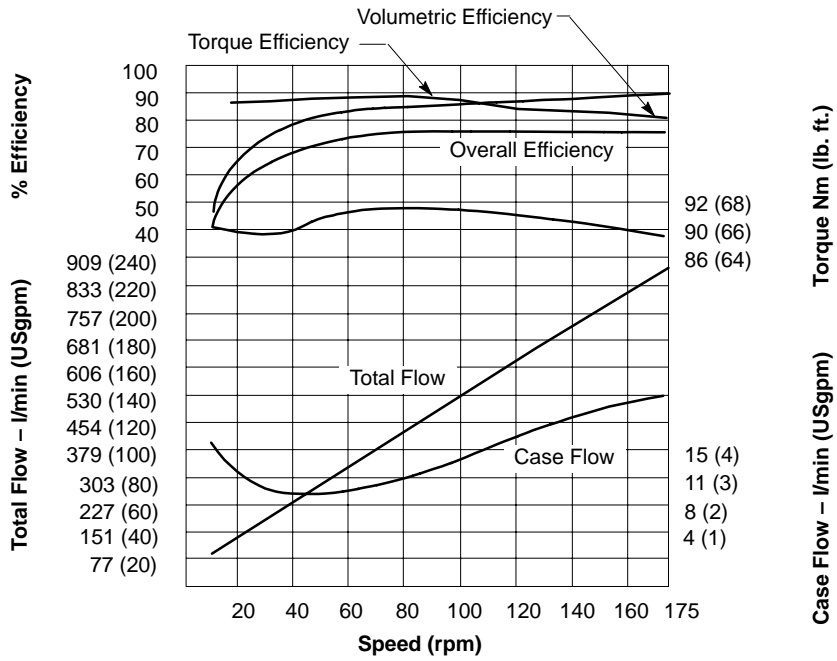

MHT 440/250/190

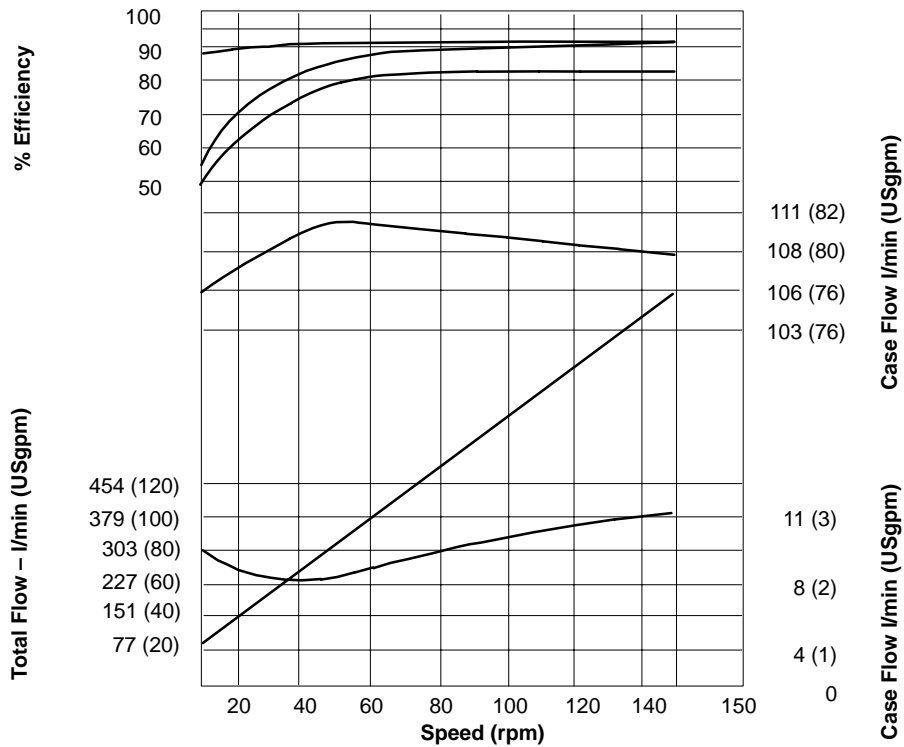

Typical half displacement performance in 180 SSU fluid @ 138 bar (2000) Δ psi

MHT 500/250/250

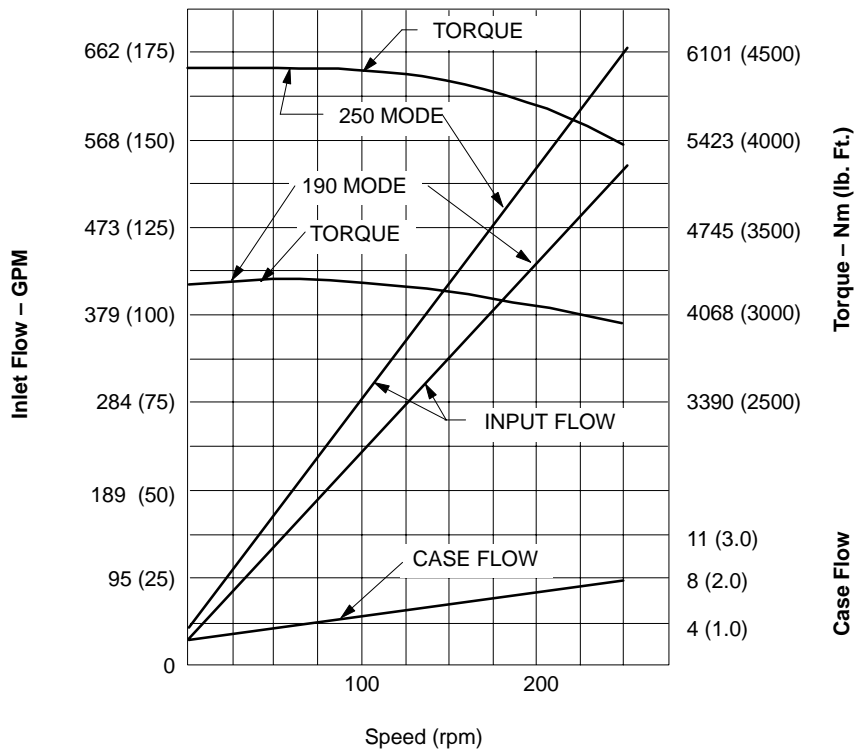

MHT 32

Installation Dimensions

Millimeters (inches)

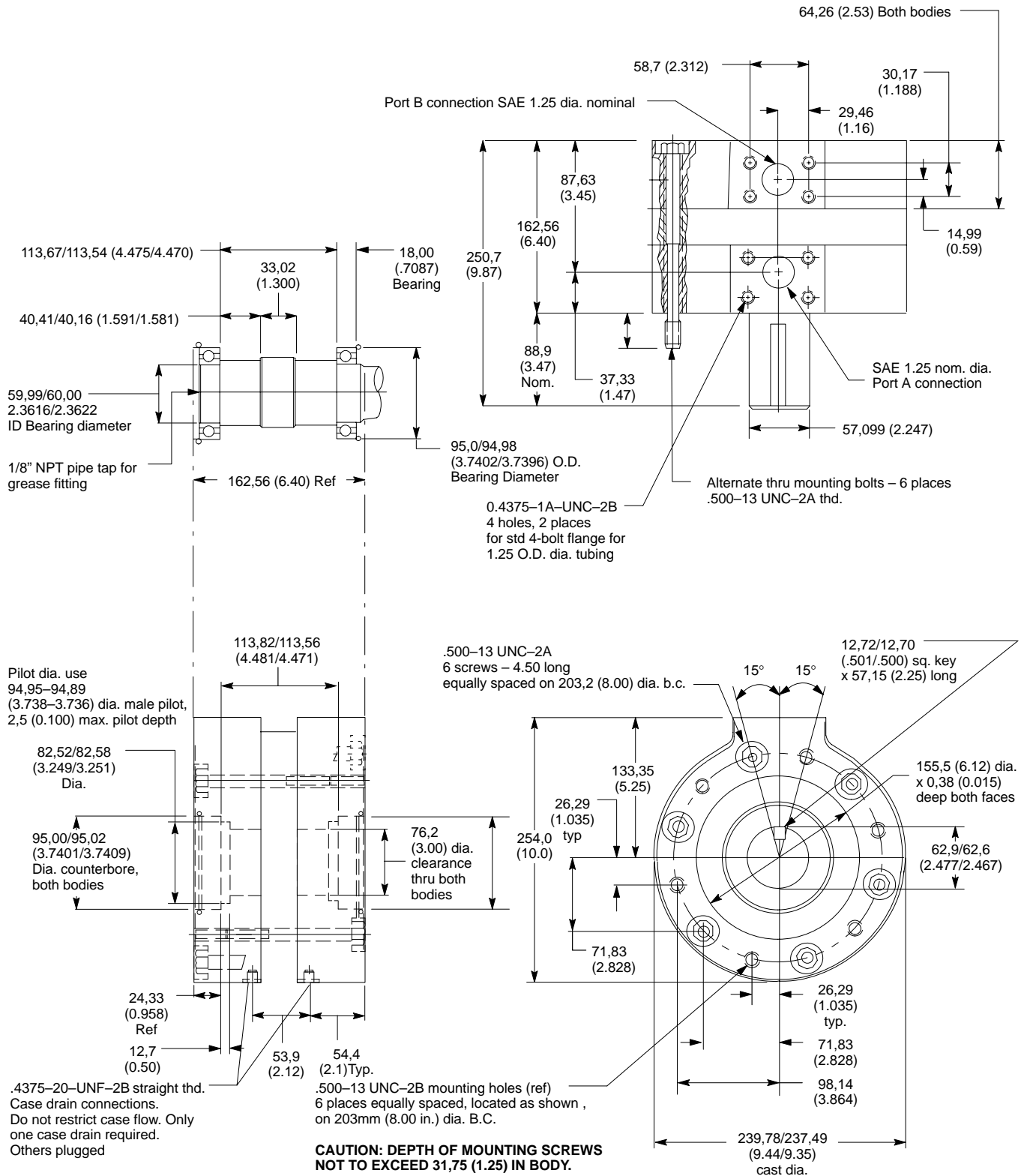

MHT 50

Installation Dimensions

Millimeters (inches)

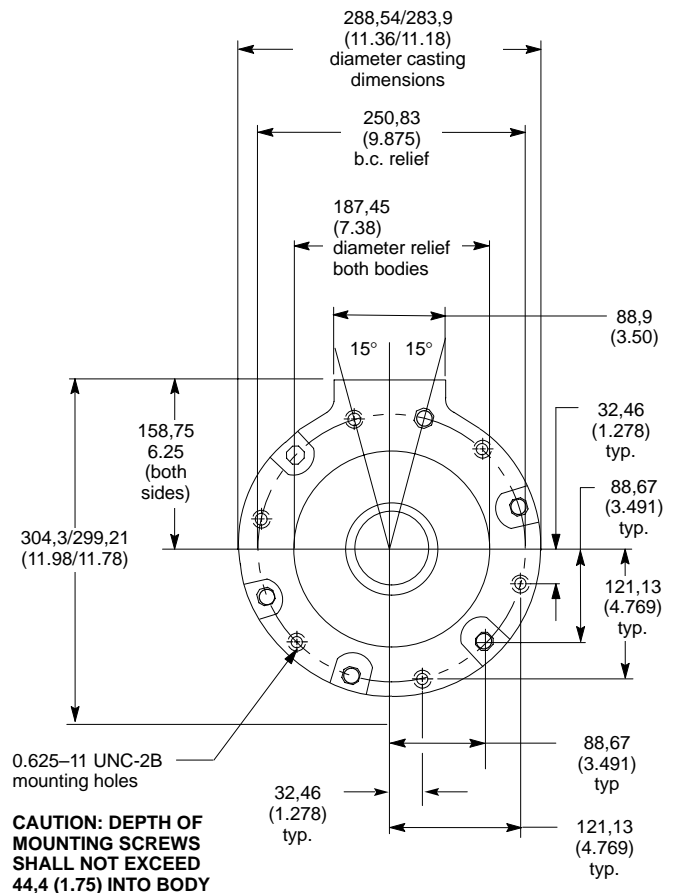
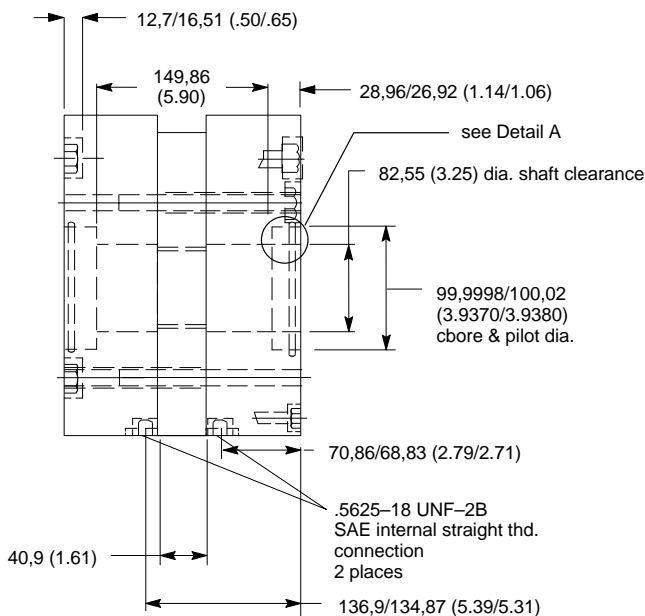
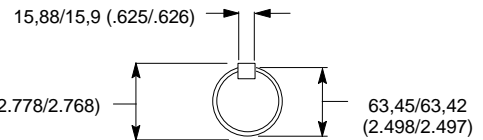
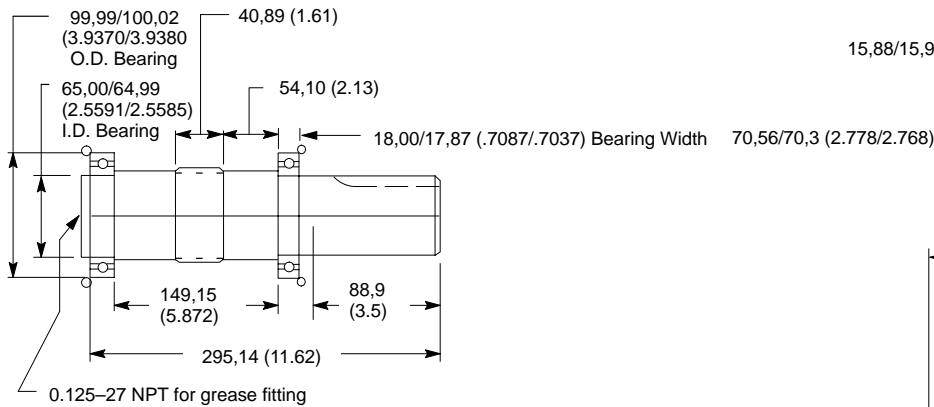
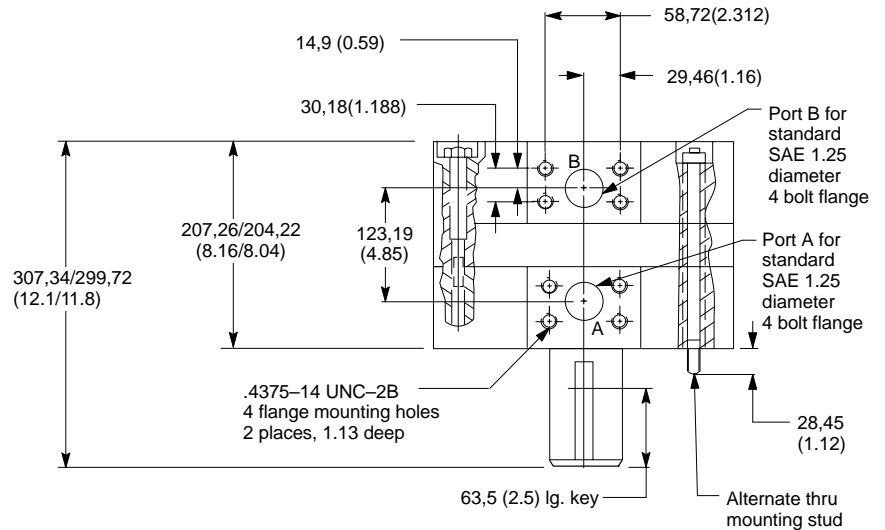
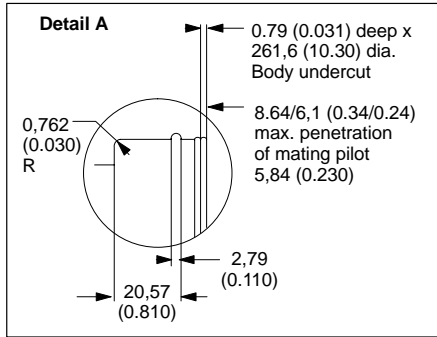

MHT 70 and 90

Installation Dimensions

Millimeters (inches)

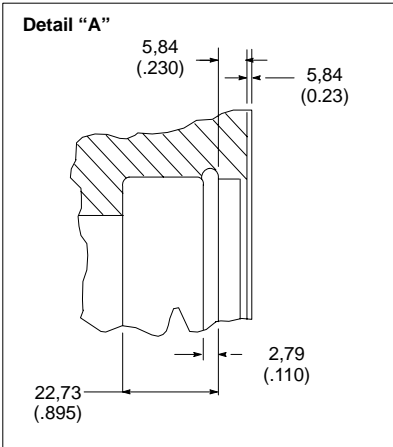

.5000-13-UNC-2B 4 flange mounting holes - 2 places

CAUTION: DEPTH OF SCREWS NOT TO EXCEED 19,05 mm (0.75 in.)

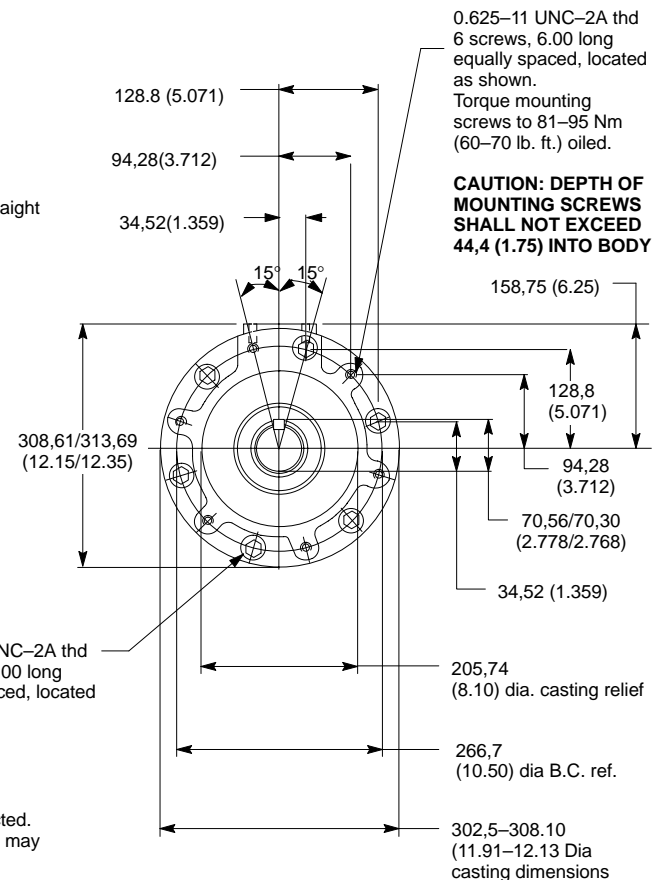
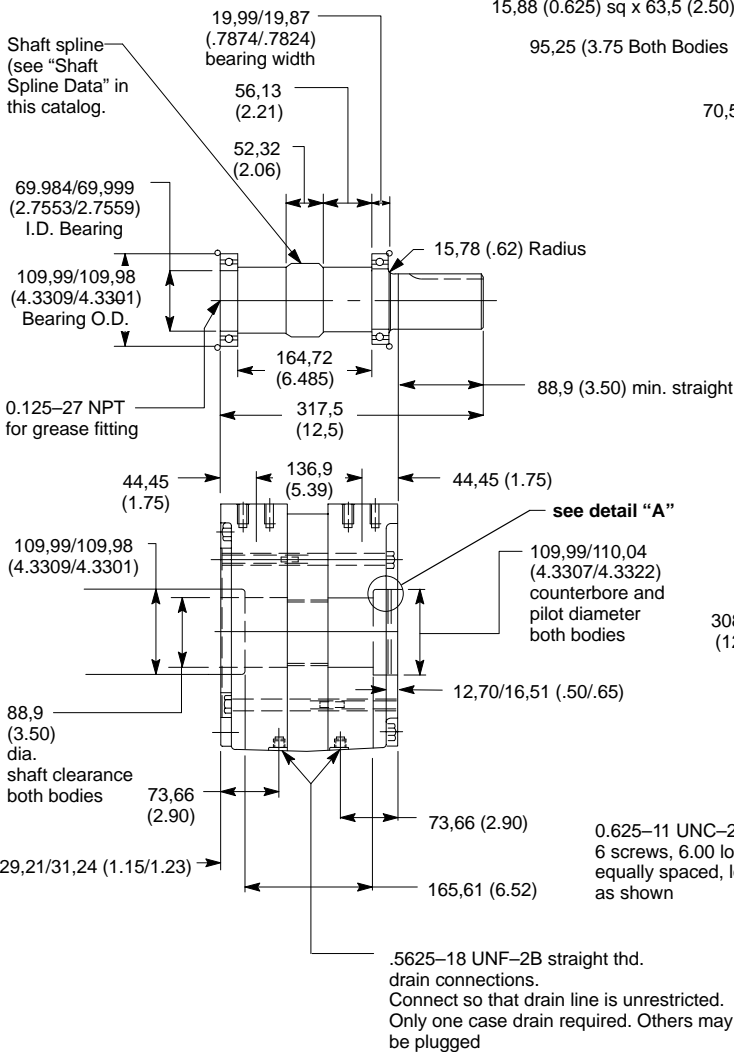
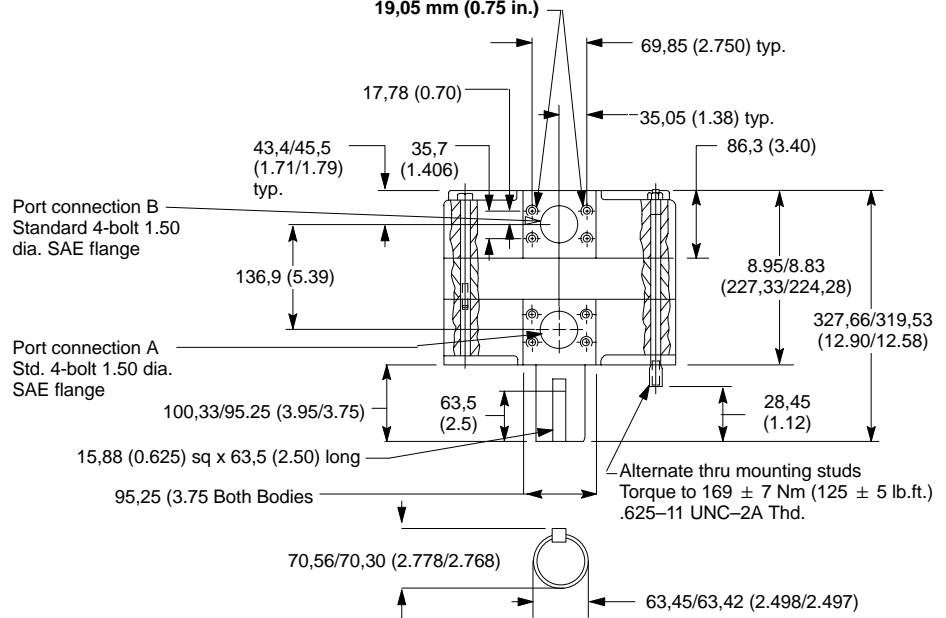

0.625-11 UNC-2A thd 6 screws, 6.00 long equally spaced, located as shown. Torque mounting screws to 81-95 Nm (60-70 lb. ft.) oiled.

CAUTION: DEPTH OF MOUNTING SCREWS SHALL NOT EXCEED 44,4 (1.75) INTO BODY

MHT 130 and MHT 150

Installation Dimensions

Millimeters (inches)

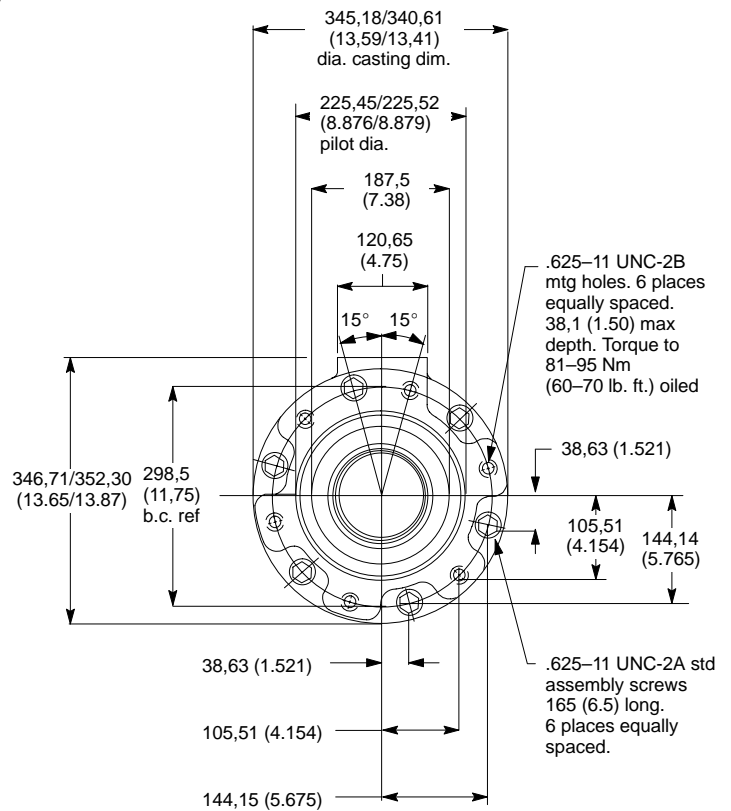
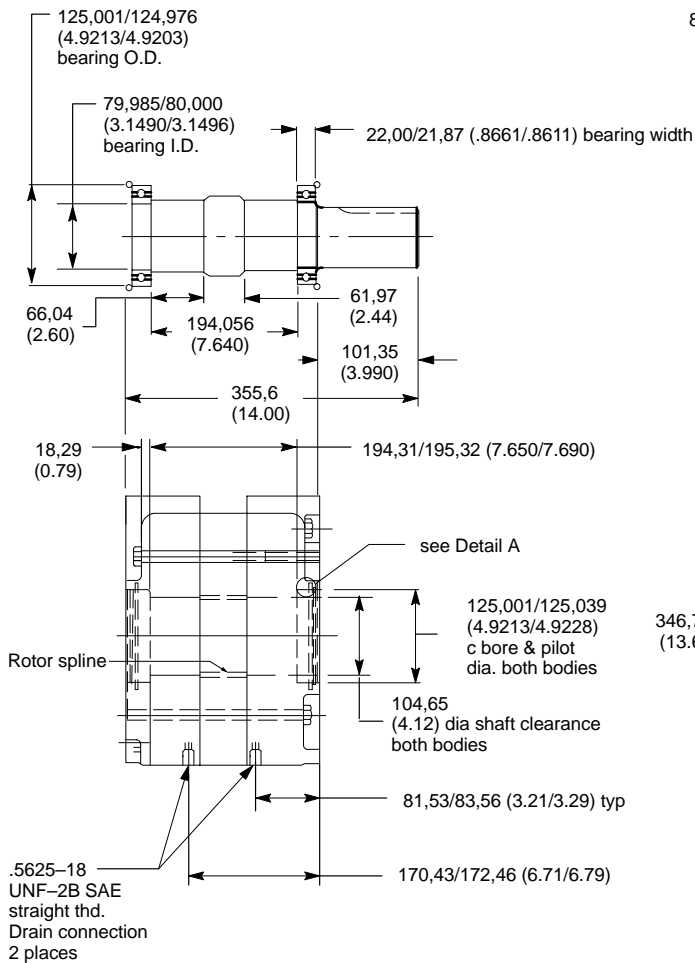
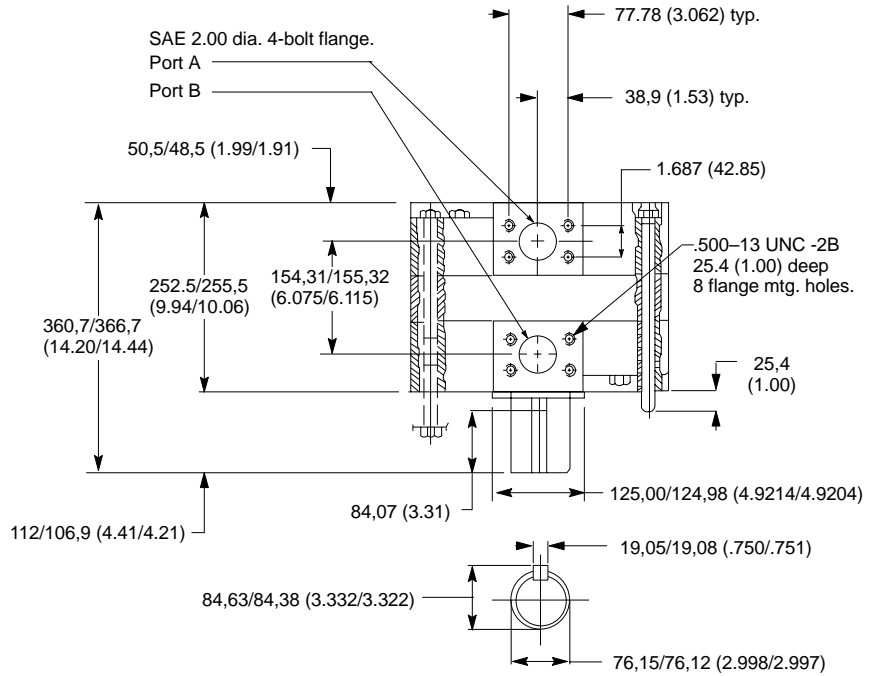
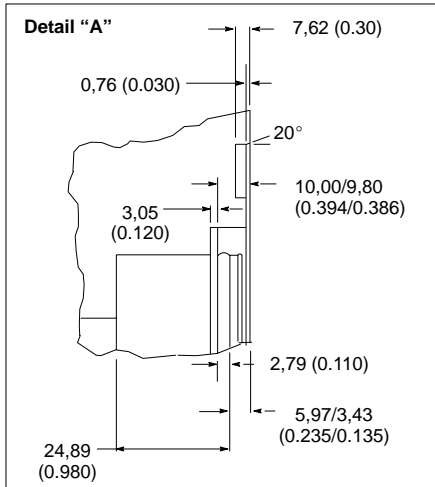

Both Bodies

MHT 190, MHT 220, MHT 250

Installation Dimensions

Millimeters (inches)

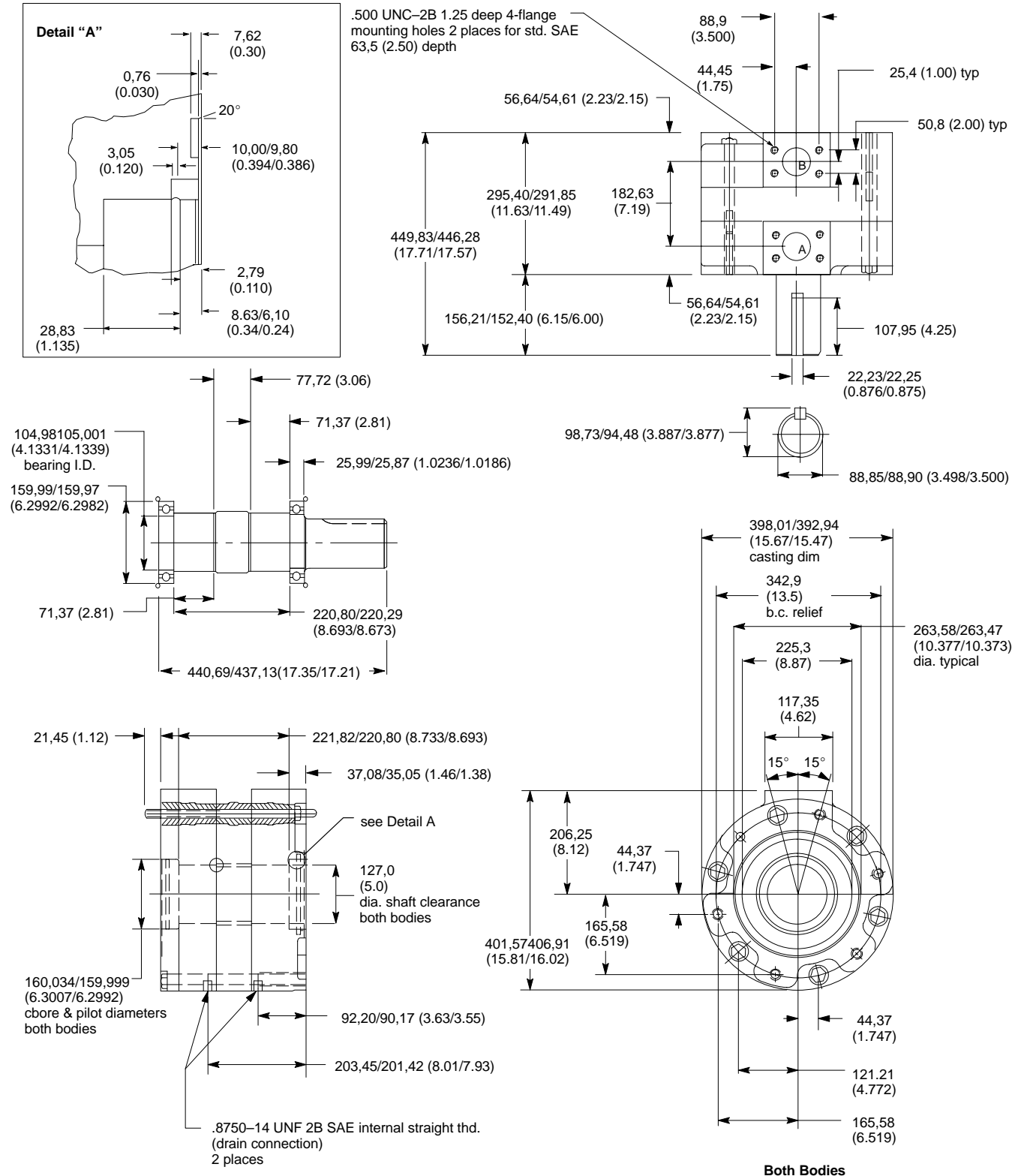

MHT 380, MHT 440, MHT 500

Installation Dimensions

Millimeters (inches)

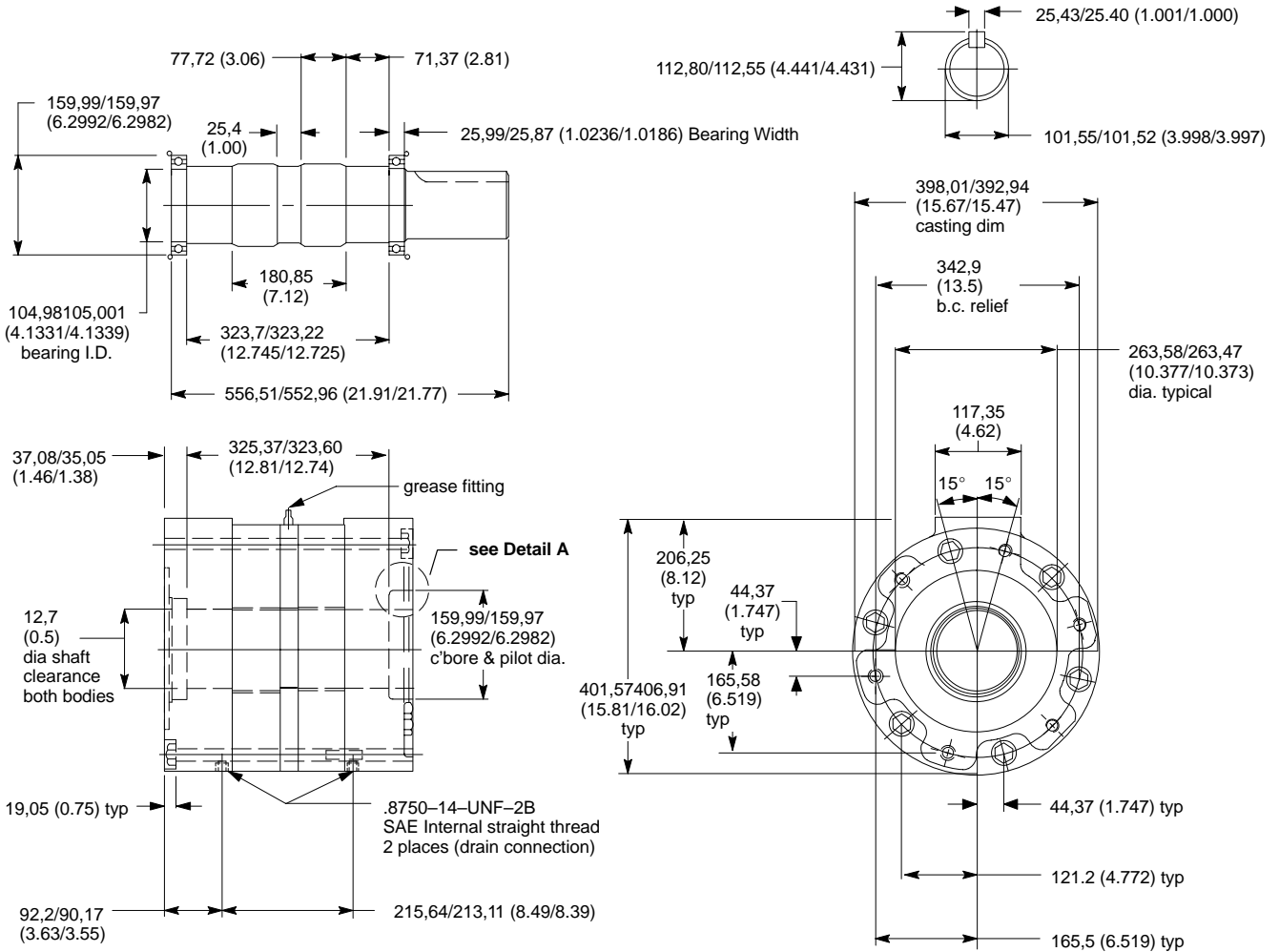
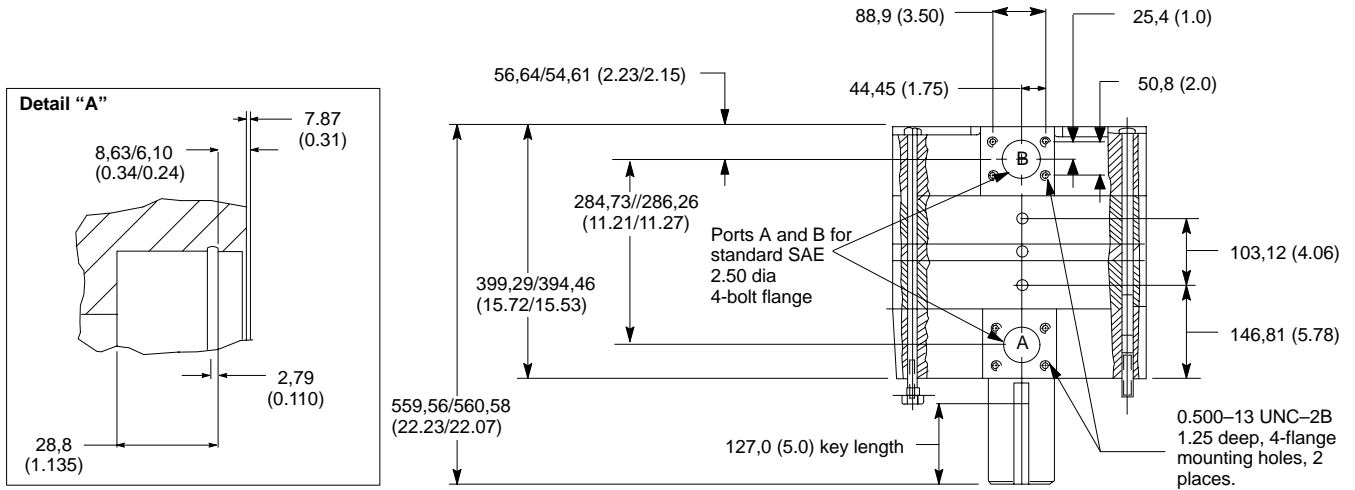

Both Bodies

MHT 750

Installation Dimensions

Millimeters (inches)

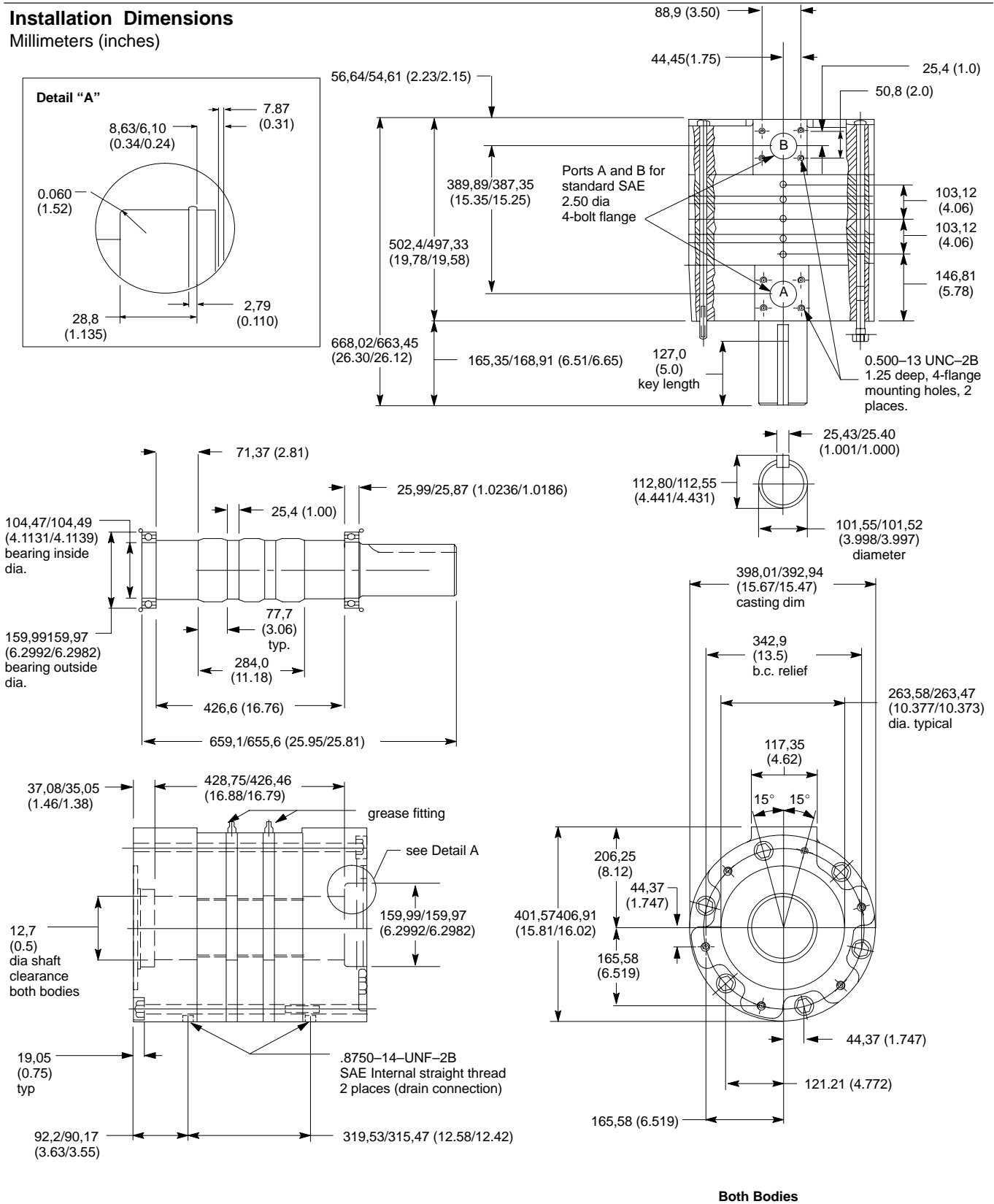

MHT 70/35/35 and MHT 90/45/45

Installation Dimensions

Millimeters (inches)

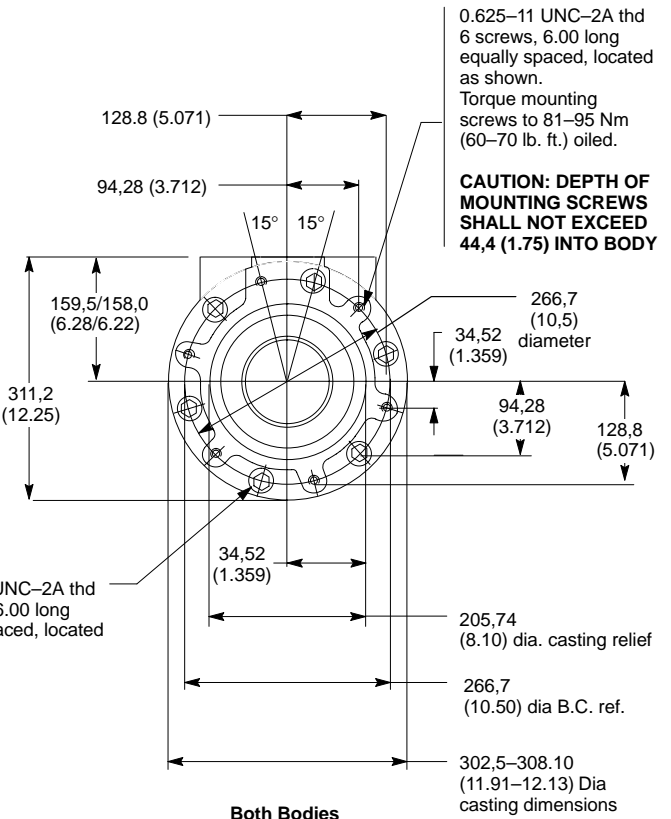
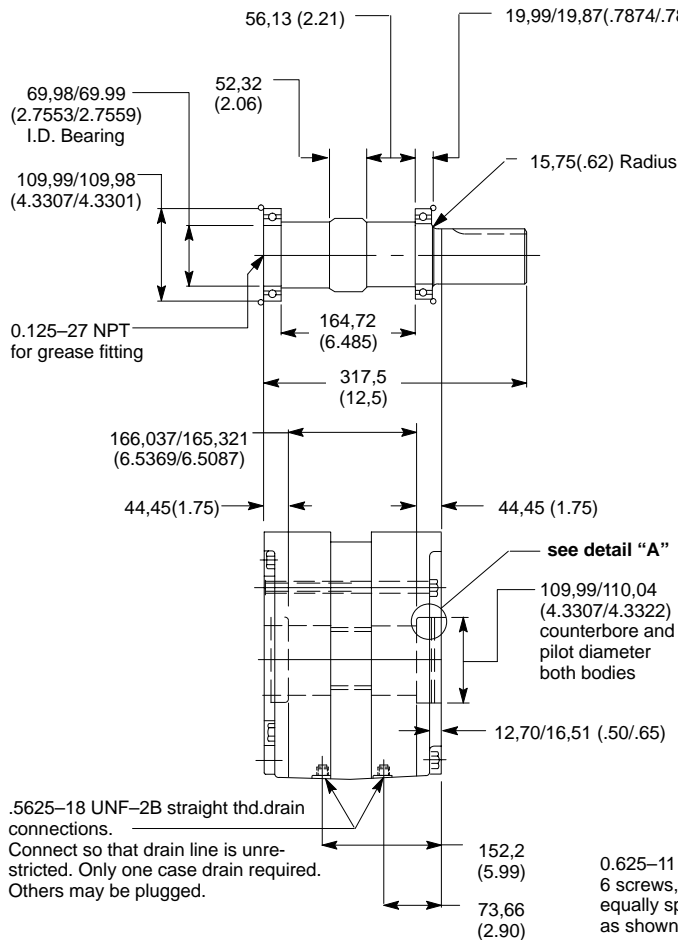
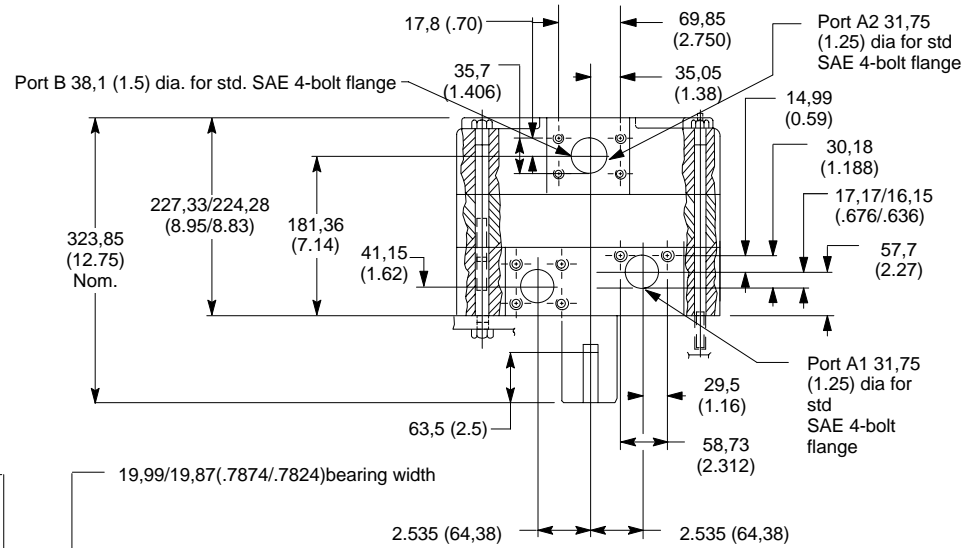
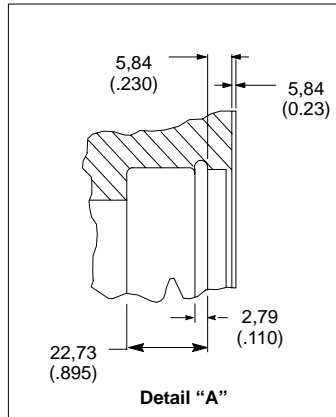

Both Bodies

MHT 130/75/55 and MHT 150/75/75

Installation Dimensions

Millimeters (inches)

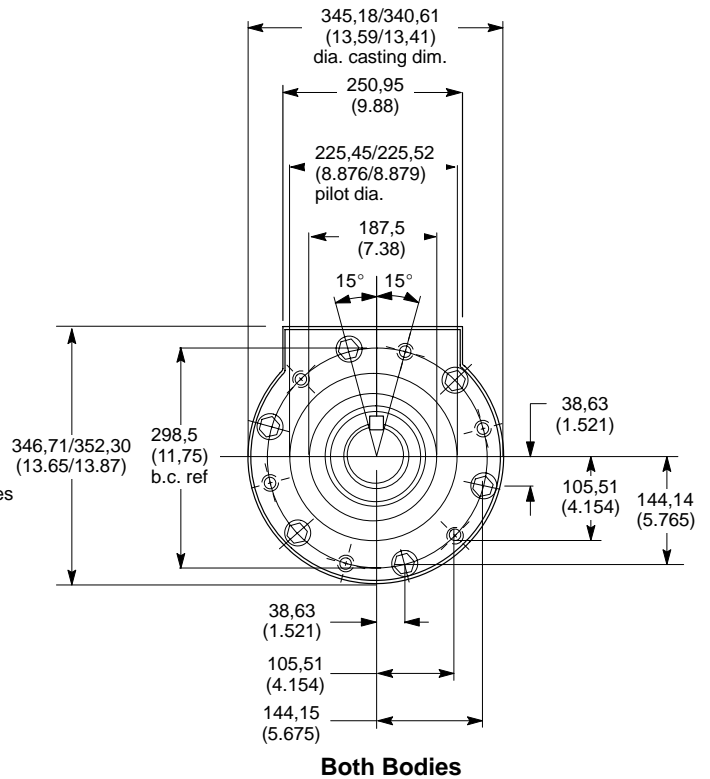
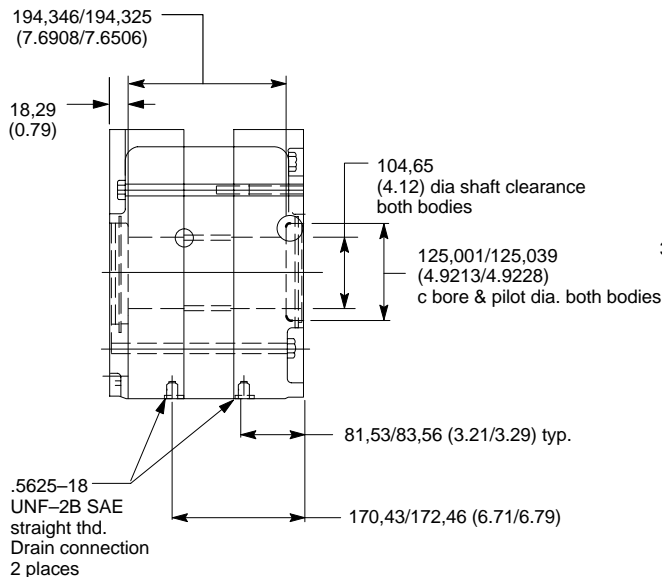
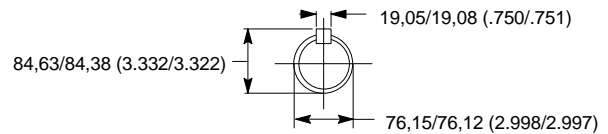
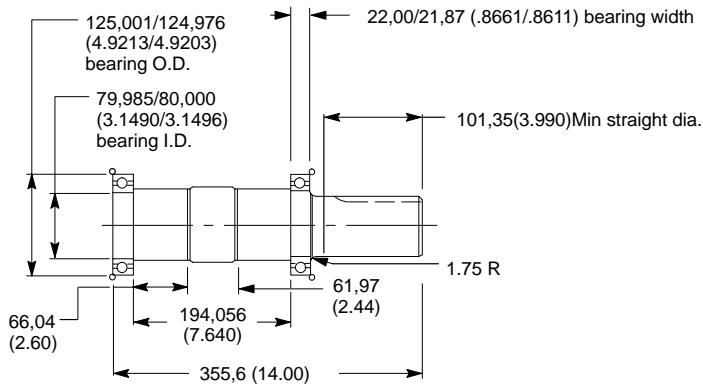
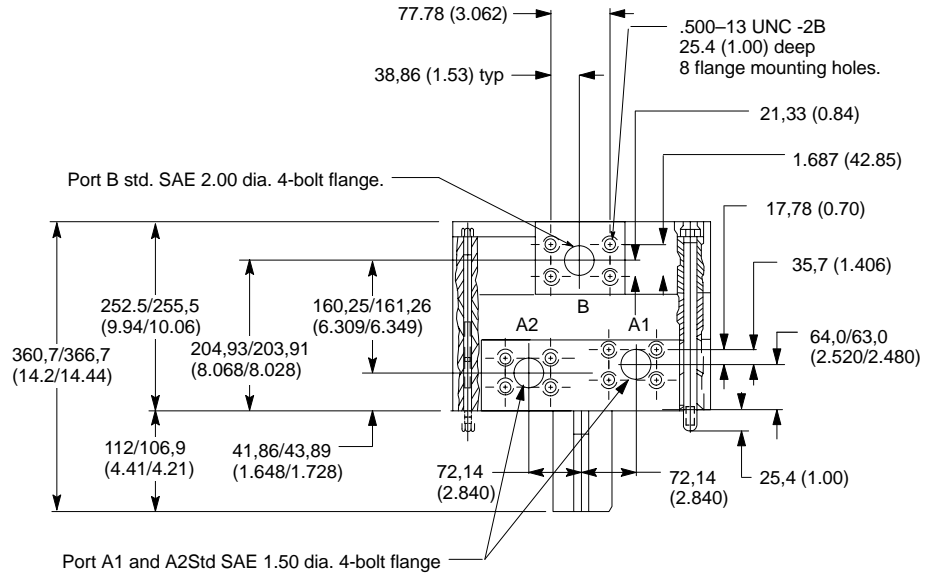
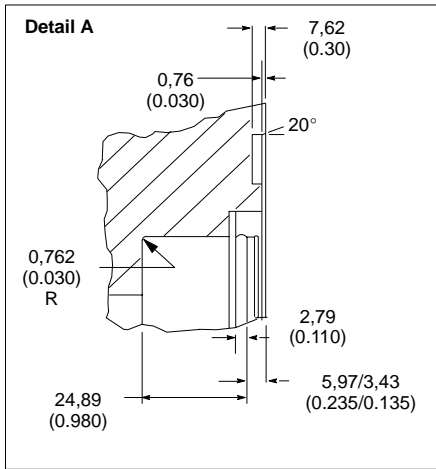

MHT 190/95/95, MHT 220/125/95, MHT 250/125/125

Installation Dimensions

Millimeters (inches)

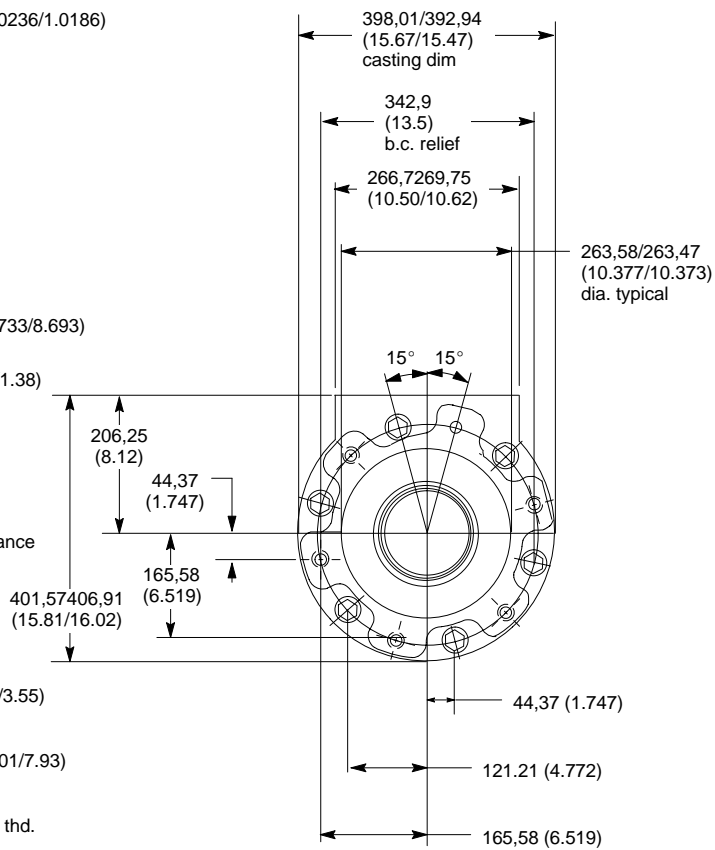
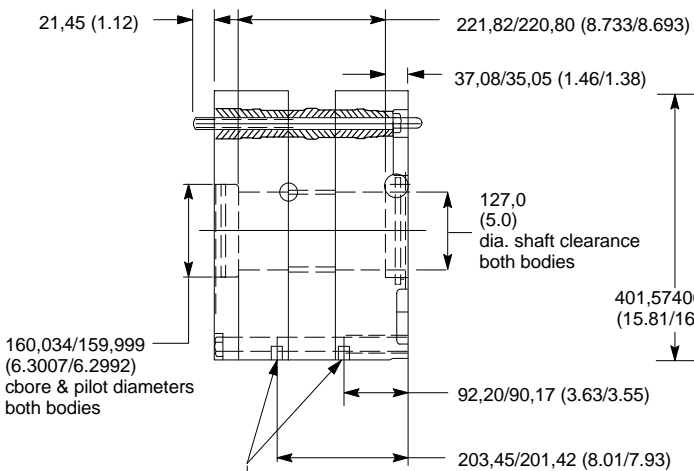
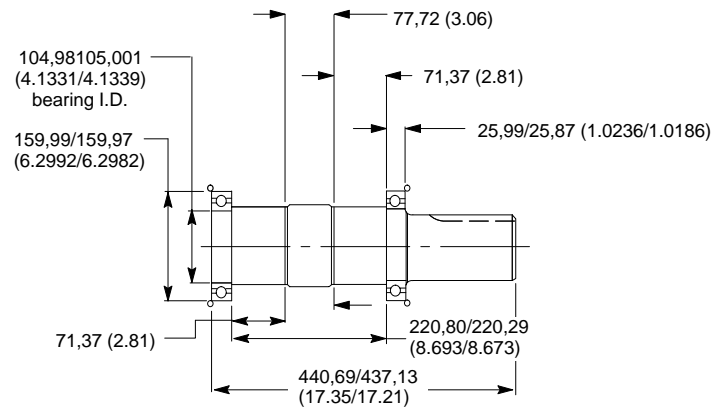
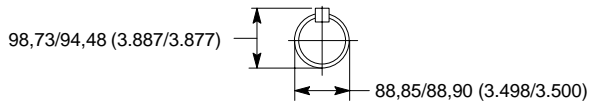
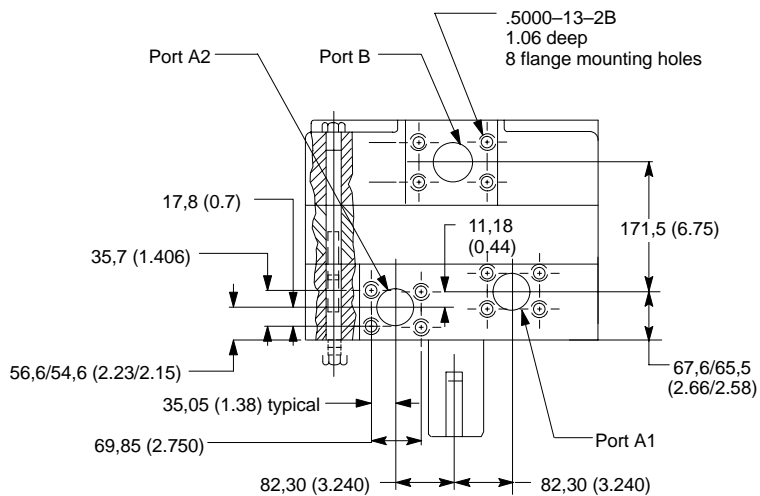
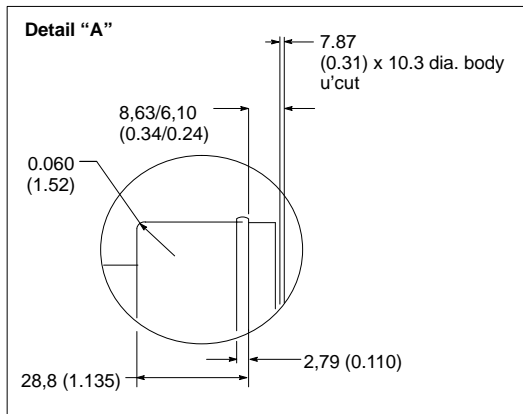

Both Bodies

MHT 380/190/190, MHT 440/250/190, MHT 500/250/250

Installation Dimensions

Millimeters (inches)

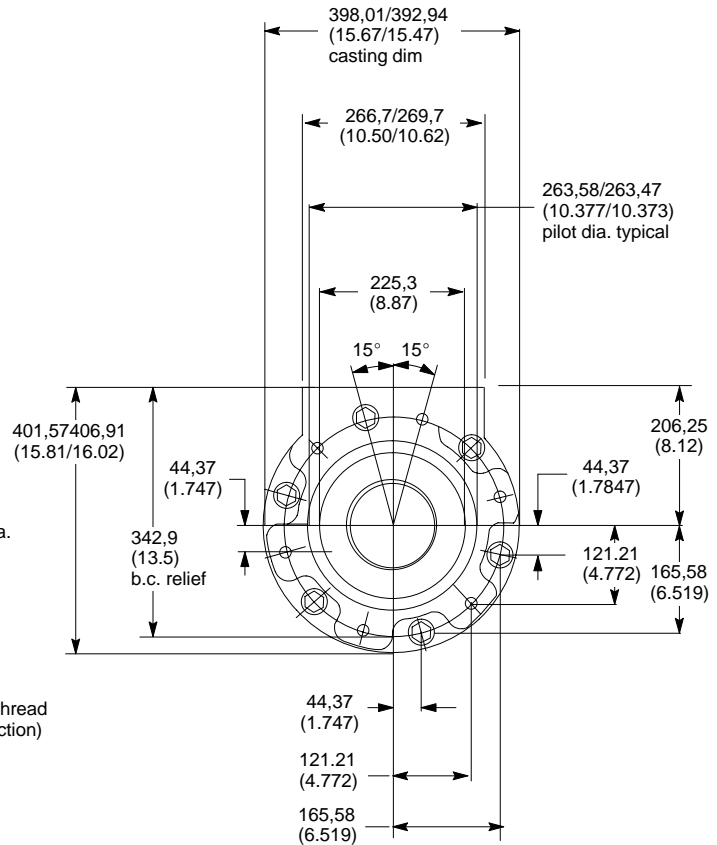
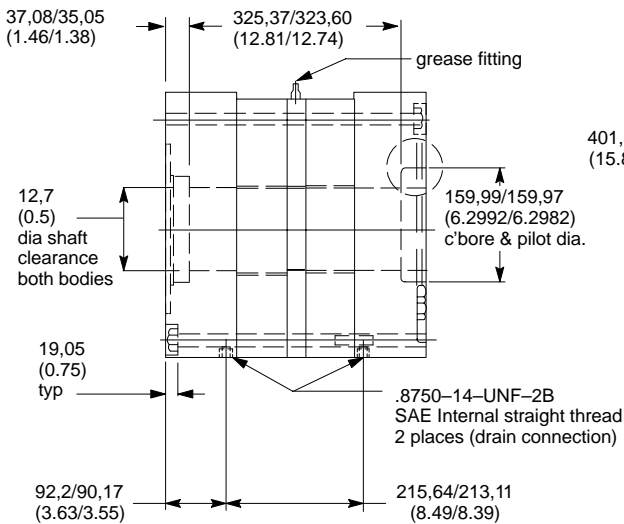
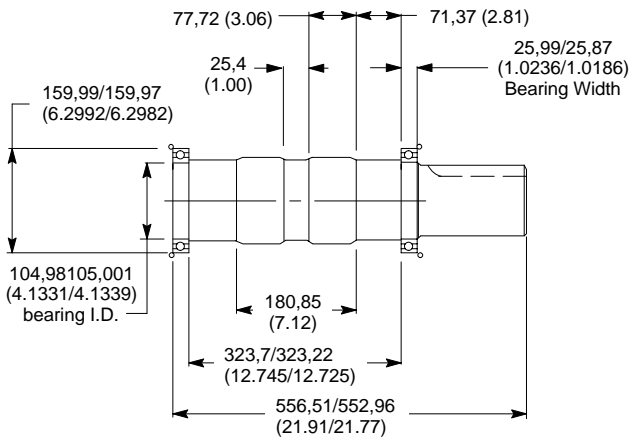
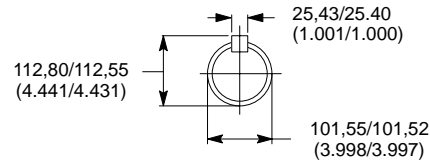
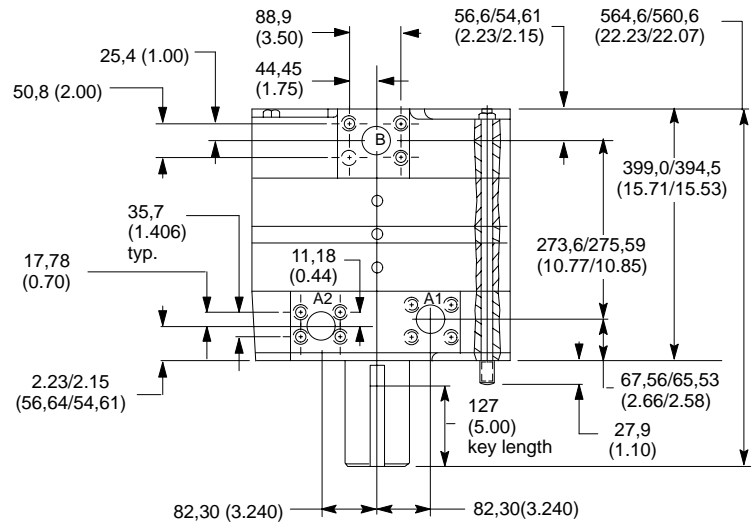
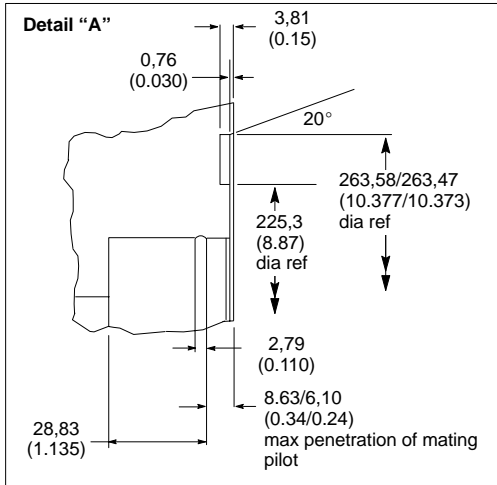

Both Bodies

MHT 1000/500/500

Installation Dimensions

Millimeters (inches)

NOTE: All other dimensions same as MHT 1000.

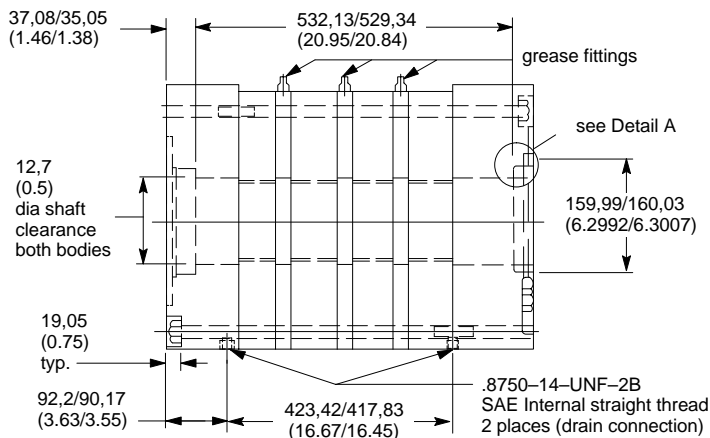
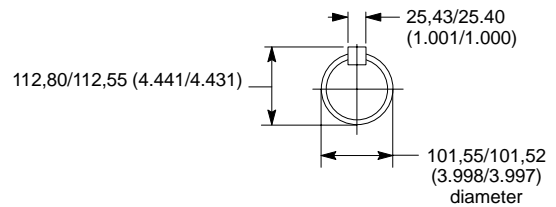
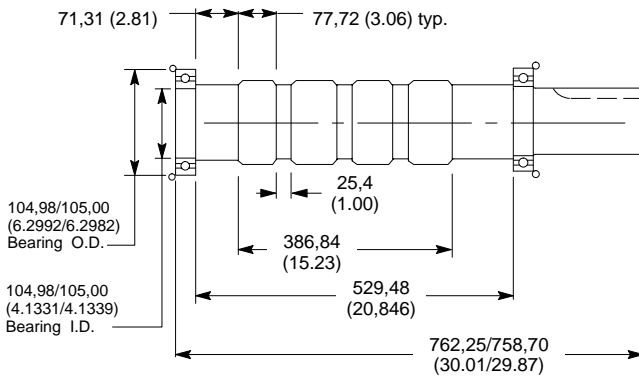
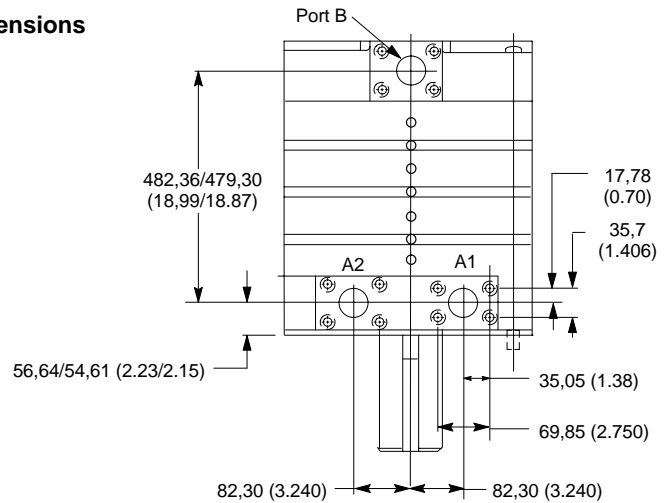
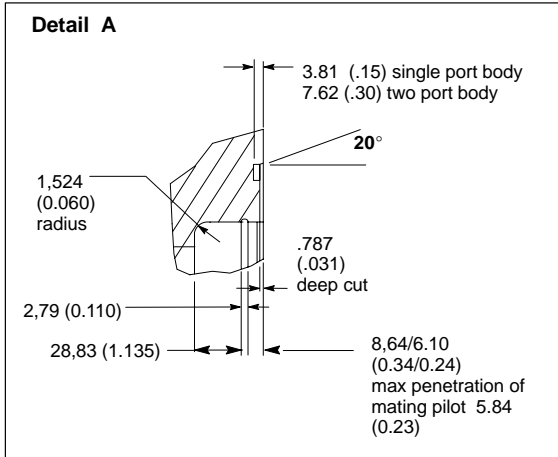

263,58/263,47 (10.377/10.373) dia. typical

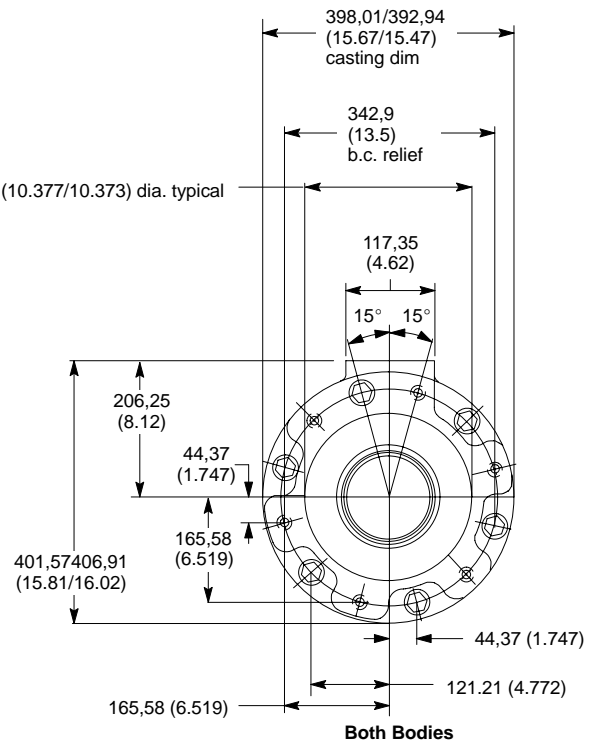

Fluid Information

Fluid Cleanliness

Proper fluid condition is essential for long and satisfactory life of hydraulic components and systems. Hydraulic fluid must have the correct balance of cleanliness, materials, and additives for protection against wear of components, elevated viscosity, and inclusion of air.

Essential information on the correct methods for treating hydraulic fluid is included in Vickers publication 561 "Vickers Guide to Systemic Contamination Control" available from your local Vickers distributor or by

contacting Vickers, Incorporated. Recommendations on filtration and the selection of products to control fluid condition are included in 561.

Recommended cleanliness levels, using petroleum oil under common conditions, are based on the highest fluid pressure levels in the system and are coded in the chart below. Fluids other than petroleum, severe service cycles, or temperature extremes are cause for adjustment of these cleanliness codes. See Vickers publication 561 for exact details.

Vickers products, as any components, will operate with apparent satisfaction in fluids with higher cleanliness codes than those described. Other manufacturers will often recommend levels above those specified. Experience has shown, however, that life of any hydraulic component is shortened in fluids with higher cleanliness codes than those listed below. These codes have been proven to provide a long, trouble-free service life for the products shown, regardless of the manufacturer.

Product	System Pressure Level bar (psi)		
	<70 (<1000)	70-210 (1000-3000)	210+ (3000+)
Vane Pumps – Fixed	20/18/15	19/17/14	18/16/13
Vane Pumps – Variable	18/16/14	17/15/13	
Piston Pumps – Fixed	19/17/15	18/16/14	17/15/13
Piston Pumps – Variable	18/16/14	17/15/13	16/14/12
Directional Valves	20/18/15	20/18/15	19/17/14
Pressure/Flow Control Valves	19/17/14	19/17/14	19/17/14
CMX Valves	18/16/14	18/16/14	17/15/13
Servo Valves	16/14/11	16/14/11	15/13/10
Proportional Valves	17/15/12	17/15/12	15/13/11
Cylinders	20/18/15	20/18/15	20/18/15
Vane Motors	20/18/15	19/17/14	18/16/13
Axial Piston Motors	19/17/14	18/16/13	17/15/12
Radial Piston Motors	20/18/14	19/17/13	18/16/13

Fluids and Seals

Fluorocarbon seals are standard and are suitable for use with phosphate ester type fluids or their blends, water glycol, water-in-oil emulsion fluids and petroleum oil.

Eaton Hydraulics, Incorporated
 14615 Lone Oak Road
 Eden Prairie, MN
 55334-2287
 Phone: (888) 258-0222
 Fax: (952) 974-7722