



AMERICAN ROTARY TOOLS CO. (ARTCO TOOLS)
 250 WEST DUARTE ROAD, #E
 MONROVIA, CALIFORNIA USA 91016-7464

Tel: (626) 358-8466 Fax: (626) 358-0076
 Toll Free US Tel: (800) 624-2212 Fax: (800) 624-2210
 Email: info@artcotools.com

Motors & Spindles Micro-grinders

Ultra-Precision Electrically / Pneumatically Driven

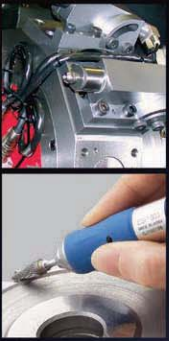

NSK America Precision & Reliability



2016 / 17
 Edition

Micro-Grinder

Air Driven



ROTUS

30,000 min⁻¹(rpm)

MODULAR TYPE HIGH TORQUE AIR GRINDER

- High torque air motor assembled with special vane mechanism.
- Two types of air motors can be selected depending on the application.
- 1/4 and 1/15 Speed Reducers (RG-01, RG-02) can be connected.
- **Lubricating oil is required.**



IMPULSE

60,000 min⁻¹(rpm)

PENCIL TYPE AIR GRINDER

- Durable and quiet high-efficient air grinder.
- The IMPULSE Series also offers 60 degree and 90 degree models. Choose the type that best fits your application requirements.
- **Lubricating oil is required.**



PRESTO II

320,000 min⁻¹(rpm)

ULTRA-PRECISION HIGH SPEED AIR TURBINE GRINDER

- Most suitable for delicate processing works due to no lube air turbine handpiece.



AMERICAN ROTARY TOOLS CO. (ARTCO TOOLS)
250 WEST DUARTE ROAD, #E
MONROVIA, CA USA 91016-7464

Tel: (626) 358-8466 Fax: (626) 358-0076
Toll Free USA Tel: (800) 624-2212 Fax: (800) 624-2210
Email: info@artcotools.com

1

EmaxEVO

ESPERT

ROTUS

IMPULSE

PRESTO II

SHEENUS

neo

SONIC

CUTTER

2

iSpeed3

E2280

ø1.0"/ø0.98"

E2280

ø0.897"

E3000

- One Piece

E3000

- Modular

ø1.18"

ø1.0"/ø0.98"

ø0.897"

E3000

- 80,000rpm

E4000

3

MA

ø0.897"

ø1.0"

ø0.98"

ø1.18"

MS

ø0.75"

ø0.79"

ø0.87"

ø0.91"

ø1.0"

ø0.98"

4

HES

HTS

HPS

PLANET

Xpeed

ABT

5

AIR LINE KIT

6

PARTS

7

TECHNICAL

DATA

8

APPLICATION

EXAMPLES

INDEX

ROTUS System Chart

1

EmaxEVO

ESPERT

ROTUS

IMPULSE

PRESTO II

SHEENUS neo

SONIC CUTTER

2

iSpeed3

E2280

ø1.0"/ø0.98"

E2280

ø0.897"

E3000

- One Piece

E3000

- Modular

ø1.18"

ø1.0"/ø0.98"

ø0.897"

E3000

- 80,000rpm

E4000

3

MA

ø0.897"

ø1.0"/ø0.98"

ø1.18"

MS

ø0.75"

ø0.79"

ø0.87"

ø0.91"

ø1.0"/ø0.98"

4

HES

HTS

HPS

PLANET

Xpeed

ABT

5

AIR LINE KIT

6

PARTS

7

TECHNICAL DATA

8

APPLICATION EXAMPLES

INDEX

CAT. No.	Model	Price
----------	-------	-------

RE11008	IR-310	303.00
---------	--------	--------

40,000 min⁻¹(rpm) Max. (*1) 40,000 min⁻¹(rpm) Max. (*2) Page 1-p8

RE10178	IH-300	303.00
---------	--------	--------

40,000 min⁻¹(rpm) Max. (*1) 40,000 min⁻¹(rpm) Max. (*2) Page 1-p8

2811	IG-400	372.00
------	--------	--------

40,000 min⁻¹(rpm) Max. (*1) 40,000 min⁻¹(rpm) Max. (*2) Page 1-p8

RE10188	HG-200	303.00
---------	--------	--------

30,000 min⁻¹(rpm) Max. (*1) 27,000 min⁻¹(rpm) Max. (*2) Page 1-p9

RE10235	BMH-300	303.00
---------	---------	--------

35,000 min⁻¹(rpm) Max. (*1) 35,000 min⁻¹(rpm) Max. (*2) Page 1-p9

RE10247	MFC-300S	289.00
---------	----------	--------

15,000 min⁻¹(rpm) Max. (*1) 15,000 min⁻¹(rpm) Max. (*2) Page 1-p9

RE10252	MFC-300M	233.00
---------	----------	--------

15,000 min⁻¹(rpm) Max. (*1) 15,000 min⁻¹(rpm) Max. (*2) Page 1-p9

RE10182	IC-300	228.00
---------	--------	--------

35,000 min⁻¹(rpm) Max. (*1) 20,000 min⁻¹(rpm) Max. (*2) Page 1-p10

RE10266	KC-300	228.00
---------	--------	--------

35,000 min⁻¹(rpm) Max. (*1) 20,000 min⁻¹(rpm) Max. (*2) Page 1-p10

LS10815	LS-100	862.00
---------	--------	--------

30,000 min⁻¹(rpm) Max. (*1) 30,000 min⁻¹(rpm) Max. (*2) Page 1-p12

LS51307	ML-8	624.00
---------	------	--------

35,000 min⁻¹(rpm) Max. (*1) 30,000 min⁻¹(rpm) Max. (*2) Page 1-p13

LS11380	SLS-16	624.00
---------	--------	--------

35,000 min⁻¹(rpm) Max. (*1) 24,000 min⁻¹(rpm) Max. (*2) Page 1-p13

RE18060	HA-500	607.00
---------	--------	--------

20,000 min⁻¹(rpm) Max. (*1) 16,000 min⁻¹(rpm) Max. (*2) Page 1-p16

KBS61065	KBS-101	612.00
----------	---------	--------

35,000 min⁻¹(rpm) Max. (*1) 35,000 min⁻¹(rpm) Max. (*2) Page 1-p16

Attachment



Ring Type



Lever Type



Straight Type



Torque Type



Long Type



90° Mini Angle Type



90° Mini Angle Type (Very Small Head)



90° Angle Type



50° Angle Type



LUSTER
(Reciprocating motion)



MINI-LUSTER (Reciprocating motion)



SWING-LUSTER (Right to Left motion)



Hammer Action Type



FINE BELT SANDER

Speed Reducer · Extension Joint



Extension Joint

RE10210	CN-01	75.00
---------	-------	-------

35,000 min⁻¹(rpm) Max. (*1) Page 1-p18
35,000 min⁻¹(rpm) Max. (*2)



1/4 Speed Reducer

RO10214	RG-01	127.00
---------	-------	--------

30,000 min⁻¹(rpm) Max. (*1) Page 1-p18
30,000 min⁻¹(rpm) Max. (*2)



1/15 Speed Reducer

RO10228	RG-02	159.00
---------	-------	--------

30,000 min⁻¹(rpm) Max. (*1) Page 1-p18
30,000 min⁻¹(rpm) Max. (*2)

* May be connected between the motor and the attachment as required for increased torque.



• Air Motor with Chip Air Mechanism
3,000~30,000 min⁻¹(rpm)

RO10163A	IM-300	433.00
----------	--------	--------

Page 1-p33



• Air Motor with 360° Twist-Free Joint
3,000~30,000 min⁻¹(rpm)

RO10163	IM-301	433.00
---------	--------	--------

Page 1-p33



• Air Line kit

4507	AL-H1207F	290.00
------	-----------	--------

*This air line kit is designed for use with the Page 5-p2 AFC-45 foot control, CAT. No.AF10045.



• Foot Control

AF10045	AFC-45	136.00
---------	--------	--------

Page 6-p9

Ultra-Precision High-Torque Air Grinder

- 30,000 min⁻¹(rpm)
- High torque air motor assembled with special vane mechanism.
- Two types of air motors can be selected depending on the application.
- 1/4 and 1/15 Speed Reducers (RG-01, RG-02) can be connected.

One Touch Tool Changing

- Ring Type (IR-310)
Ring operated open/close chuck



Twist Free Hose

To prevent twisting of the hose, 360° Twist- Free Joint connects the motor and the hose.

A Special Rotary Vane Air Motor is Incorporated

The air motor utilizes a special vane design which keeps constant speed even under load providing stable grinding and polishing operation.

Wide-range of Collet Sizes

Various sizes ranging from ultra-small diameter (0.3 mm) are available for each attachment. Furthermore, collet replacement can be easily performed without wrench.

Ring Switch

Assembled with ON/OFF, speed control and FWD./REV. control ring switch.

14 Types of Attachments for All Types of Applications

Capable of infinite applications with 14 different attachments.

* Interchangeable with attachments from the Emax EVOLution series.



Special Dust Protection Mechanism (patented)

The chuck section of ROTUS has a special built-in dust protection mechanism that prevents entry of foreign matter such as chips and provides superior durability.

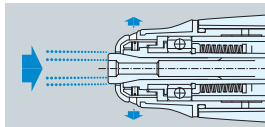

Attachment IR-310 + Air motor IM-301

Specifications

Speed	: Max. 30,000 min ⁻¹ (rpm) (58PSI)
Proper Air Pressure	: 44~65PSI
Air Consumption	: 2.65CFM
Output Power	: 46W (motor)
Max. Torque	: 6.6 cN · m (58PSI)
Motor	: Air motor IM-301
Dimensions	: Air motor (IM-301) + Attachment (IR-310) See left figures
Weight	: Air motor (IM-301) + Attachment (IR-310) : 7.83 oz.

1

EmaxEVO

ESPERT

ROTUS

IMPULSE

PRESTO II

SHEENUS neo

SONIC CUTTER

2

iSpeed3

E2280 ø1.0"/ø0.98"

E2280 ø0.897"

E3000 - One Piece

E3000 - Modular

ø1.18"

ø1.0"/ø0.98"

ø0.897"

E3000 - 80,000rpm

E4000

3

MA

ø0.897"

ø1.0"/ø0.98"

ø0.897"

ø1.18"

MS

ø0.75"/ø0.79"

ø0.87"/ø0.91"

ø1.0"/ø0.98"

ø0.897"

4

HES

HTS

HPS

PLANET

Xspeed

ABT

5

AIR LINE KIT

6

PARTS

7

TECHNICAL DATA

8

APPLICATION EXAMPLES

INDEX

“ROTUS” STANDARD SET

1

EmaxEVO

ESPERT

ROTUS

IMPULSE

PRESTO II

SHEENUS
neo

SONIC
CUTTER

2

iSpeed3

E2280

ø1.0"/ø0.98"

E2280

ø0.897"

E3000

- One Piece

E3000

- Modular

ø1.18"

ø1.0"/ø0.98"

E3000

- 80,000rpm

E4000

3

MA

ø0.897"

ø1.0"/ø0.98"

ø1.18"

MS

ø0.75"

ø0.79"

ø0.87"

ø0.91"

ø1.0"

ø0.98"

4

HES

HTS

HPS

PLANET

Xpeed

ABT

5

AIR LINE KIT

6

PARTS

7

TECHNICAL
DATA

8

APPLICATION
EXAMPLES

INDEX

CAT. No. 1148 ROTUS STANDARD SET (Ring Type)



The ROTUS System is a hand-held grinder with an energy saving air motor. Since it is an air driven system, there is virtually no heat generation resulting in excellent durability. Select from a variety of attachments depending on the application.

30,000 min⁻¹(rpm)

*The new ring type IR-310 is the standard attachment for ROTUS standard set R301-IR.

CAT.No.	1148	Model	R301-IR	Price	1,090.00
			Attachment IR-310	Motor IM-301	
Standard Equipment	Air Grinder (IM-301+IR-310) : 1 pc. Collet ø1/8" (CHH-3.175), ø2.35 mm (CHH-2.35) : 1 pc. each Air Line Kit (AL-H1207F) : 1 pc. Foot Control (AFC-45) : 1 pc. Hose for Piping (K-275) 6 ft : 1 pc. Lubricating Oil (K-211) : 1 pc. Wrench (7 x 5.1) : 1 pc. Pin Wrench (K-233) : 2 pcs. L Shaped Wrench (9) : 1 pc.				

AMERICAN ROTARY TOOLS CO. Toll Free US & CA +1 (800) 645-3824

“ROTUS” MOTOR

AMERICAN ROTARY TOOLS CO.

www.artcotools.com

Motor for ROTUS (Pneumatically Driven)

Air motor designed for high-efficiency

To achieve high torque, ROTUS air motor is assembled with micron precision between the vanes and the internal surface of cylinder using NAKANISHI's proprietary techniques. This high performance air motor with minimal power loss from load fluctuation has excellent performance in its grinding stability. Moreover, the motor with minimal air consumption runs quietly and the energy-saving mechanism makes it possible to operate with a 1 hp (0.75KW) air compressor.

Air Cooling System generates no heat for a continuous operation

The motor prevents heat generation and expansion of metal by air cooling system and provides stable rotation speed.

Light-weight and compact design

The motor with attachment IR-310 is only 7.83 oz. Its light-weight and well balanced design provides excellent grinding performance.

Assembled with Speed Control and Forward/Reverse Control Ring

Forward/Reverse Rotating Direction Control Ring located at the end of the motor can control the motor speed as well.

Speed control by Foot Control

Fine adjustment of variable speed can be controlled by Foot Control.

Excellent quietness with Silencer

By attaching the silencer to the end of the exhaust air tubing, the motor is operated extremely quiet.

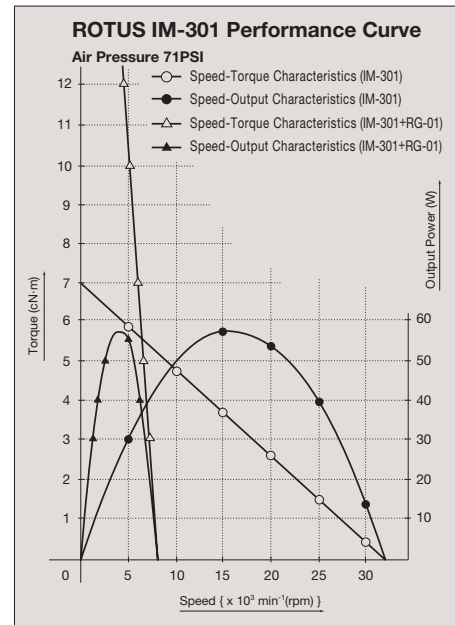

CAT. No. R010163 AIR MOTOR IM-301 (with Twist-Free Joint Mechanism)

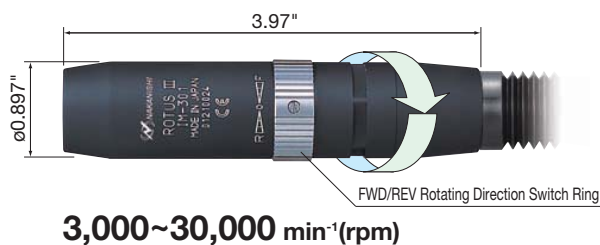

Air Motor with 360° Twist-Free Joint Mechanism

- Adopted Twist-Free Joint mechanism between the motor and the hose has solved the problem of hose twisting.
- Weight : 4.59 oz. excluding hose

CAT. No.	Model	Standard Accessories	Price
R010163	IM-301	<ul style="list-style-type: none"> • Hose (K-206) : 6 ft • Silencer (K-209) • Pin Wrench (K-233) : 1 pc. 	433.00

CAT. No. R010163A AIR MOTOR IM-300 (with Chip Air Mechanism)



Air Motor with Chip Air Mechanism

- Air motor IM-300 with Chip Air mechanism blows away the cutting dust with clean air coming through the top end of the attachment. The hand-held cutting work remains cool by the chip air allowing comfort through out the working process. (This is only with the attachment IH-300)
- Weight : 4.59 oz. excluding hose

CAT. No.	Model	Standard Accessories	Price
R010163A	IM-300	<ul style="list-style-type: none"> • Hose (K-207) : 6 ft • Silencer (K-209) • Pin Wrench (K-233) : 1 pc. 	433.00

1

EmaxEVO

ESPERT

ROTUS

IMPULSE

PRESTO II

SHEENUS neo

SONIC CUTTER

2

iSpeed3

E2280

ø1.0"/ø0.98"

E2280

ø0.897"

E3000

- One Piece

E3000

- Modular

ø1.18"

ø1.0"/ø0.98"

ø0.897"

E3000

- 80,000rpm

E4000

3

MA

ø0.897"

ø1.0"/ø0.98"

ø0.897"

ø1.18"

MS

ø0.75"/ø0.79"

ø0.87"/ø0.79"

ø1.0"/ø0.91"

ø1.0"/ø0.98"

ø0.897"

4

HES

HTS

HPS

PLANET

Xpeed

ABT

5

AIR LINE KIT

6

PARTS

7

TECHNICAL DATA

8

APPLICATION EXAMPLES

INDEX

"Emax EVOLution" & "ROTUS" ATTACHMENTS

CAT. No. RE11008 RING TYPE ATTACHMENT IR-310



40,000 min⁻¹(rpm) Max. (*1)
40,000 min⁻¹(rpm) Max. (*2)



- Perfectly designed for powerful and delicate cutting and grinding, and made slim and light weight for comfortable gripping.

- Weight : 3.25 oz.
- Simple, no wrench bur replacement.
- Wrench is not required to exchange the chuck.
- Collet
Standard Size : $\phi 1/8"$ (CHH-3.175),
 $\phi 2.35$ mm (CHH-2.35)
- Optional Collets: CHH-[] are shown in page (6-p2)

Ring Type Attachment

CAT. No.	Model	Standard Accessories	Price
RE11008	IR-310	<ul style="list-style-type: none"> ● Collet $\phi 1/8"$ (CHH-3.175), $\phi 2.35$ mm (CHH-2.35) : 1 pc. each ● Wrench (7 x 5.1) : 1 pc. ● Pin Wrench (K-233) : 1 pc. ● L Shaped Wrench (9) : 1 pc. 	303.00

CAT. No. RE10178 LEVER TYPE ATTACHMENT IH-300



40,000 min⁻¹(rpm) Max. (*1)
40,000 min⁻¹(rpm) Max. (*2)



- Perfectly designed for powerful and delicate cutting and grinding, and made slim and light weight for comfortable gripping.

- Weight : 2.19 oz.
- Just turn the lever to exchange the bur.
- Wrench is not required to exchange the chuck.
- Collet
Standard Size : $\phi 1/8"$ (CHH-3.175),
 $\phi 2.35$ mm (CHH-2.35)
- Optional Collets: CHH-[] are shown in page (6-p2)

Lever Type Attachment

CAT. No.	Model	Standard Accessories	Price
RE10178	IH-300	<ul style="list-style-type: none"> ● Collet $\phi 1/8"$ (CHH-3.175), $\phi 2.35$ mm (CHH-2.35) : 1 pc. each ● Wrench (7 x 5.1) : 1 pc. ● Pin Wrench (K-233) : 1 pc. 	303.00

CAT. No. 2811 STRAIGHT TYPE ATTACHMENT IG-400



40,000 min⁻¹(rpm) Max. (*1)
40,000 min⁻¹(rpm) Max. (*2)



- Light weight ergonomically designed with minimal vibration for extended use.
- High precision NK Micron Collet for maximum tool retention.

- Weight : 1.94 oz.
- Collet
Standard Size : $\phi 1/8"$ (NKM6-3.175)
- Optional Collets: NKM6-[] are shown in page (6-p6)

Straight Type Attachment

CAT. No.	Model	Standard Accessories	Price
2811	IG-400	<ul style="list-style-type: none"> ● Collet $\phi 1/8"$ (NKM6-3.175) : 1 pc. ● Collet Nut (CHN-6) : 1 pc. ● Wrench (9 x 9), (15 x 17) : 1 pc. each ● Bar Wrench (PCR-30) : 1 pc. 	372.00

CAT. No. RE10188 TORQUE TYPE ATTACHMENT HG-200

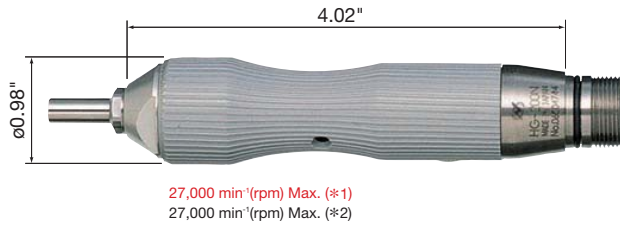

- The resistance produced by cutting and grinding is absorbed by a special rubber grip to eliminate slipping.
- Chuck is tightened by a Wrench.
- Weight : 7.41 oz.
- Collet
Standard Size : $\phi 1/4"$ (CHG-6.35)
Optional Collets: CHG-□□ are shown in page (6-p2)

Torque Type Attachment *Use 6mm torque Type HG-200 to connect ENK-250T *Please use it with Speed Reducer. (ROTUS Air Motor)

CAT. No.	Model	Standard Accessories	Price
RE10188	HG-200	<ul style="list-style-type: none"> ● Collet $\phi 1/4"$ (CHG-6.35) : 1 pc. ● Wrench (10 x 10) : 1 pc. ● Bar Wrench (K-212) : 1 pc. ● Pin Wrench (K-233) : 1 pc. 	303.00

CAT. No. RE10235 For Deep Hole Grinding LONG ATTACHMENT BMH-300

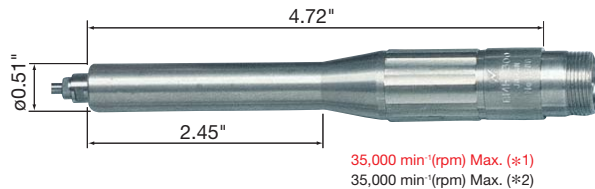

- This unique slim body makes it ideal for cutting and grinding the bottom surface of deep ribs or holes.
- Weight : 5.50 oz.
- Wrench is not required to exchange the chuck.
- Collet
Standard Size : $\phi 1/8"$ (CHM-3.175)
Optional Collets : CHM-□□ are shown in page (6-p4)

Long Attachment for Deep Hole Grinding

CAT. No.	Model	Standard Accessories	Price
RE10235	BMH-300	<ul style="list-style-type: none"> ● Collet $\phi 1/8"$ (CHM-3.175) : 1 pc. ● Wrench (7 x 5.1), (6 x 4.5) : 1 pc. each ● Pin Wrench (K-233) : 1 pc. 	303.00

CAT. No. RE10247 For Chamfering Deep Hole 90° MINI ANGLE TYPE ATTACHMENT MFC-300S



- Ideal for chamfering and deburring the inside of slit pipe.
- Minimum Inner Diameter : $\phi 0.79"$
- Weight : 1.76 oz.
- Standard Collet : $\phi 1.6$ mm (K-252)
- Speed Reduction Ratio : 10/11

90° MINI ANGLE TYPE Attachment for Chamfering Deep Hole, Bur Only $\phi 1.6$ mm *Please use it with Speed Reducer. (ROTUS Air Motor)

CAT. No.	Model	Standard Accessories	Price
RE10247	MFC-300S	<ul style="list-style-type: none"> ● Collet $\phi 1.6$ mm (K-252) : 1 pc. ● Chuck Wrench (K-232) : 1 pc. ● Pin Wrench (K-233) : 1 pc. 	289.00

CAT. No. RE10252 For Chamfering Deep Hole 90° MINI ANGLE TYPE ATTACHMENT MFC-300M



- The smallest 90° Angle type head is suitable for chamfering and deburring the inside of the slit pipe.
- Minimum Inner Diameter : $\phi 0.51"$
- Weight : 1.66 oz.
- Standard Collet : $\phi 1.6$ mm (K-253)
- Speed Reduction Ratio : 10/11

90° MINI ANGLE TYPE Attachment for Chamfering Deep Hole, Bur Only $\phi 1.6$ mm (Very Small Head) *Please use it with Speed Reducer. (ROTUS Air Motor)

CAT. No.	Model	Standard Accessories	Price
RE10252	MFC-300M	<ul style="list-style-type: none"> ● Collet $\phi 1.6$ mm (K-253) : 1 pc. ● Chuck Wrench (K-232) : 1 pc. ● Pin Wrench (K-233) : 1 pc. 	233.00

*Maximum Allowable Speed, continuous use may change depending on the material being cut and other application variables.

*1 : Maximum Allowable Speed, intermittent use.
*2 : Maximum Allowable Speed, continuous use.

1
EmaxEVO
ESPERT
ROTUS
IMPULSE
PRESTO II
SHEENUS neo
SONIC CUTTER
2
iSpeed3
E2280 $\phi 1.0"/\phi 0.98"$
E2280 $\phi 0.897"$
E3000 - One Piece
E3000 - Modular
$\phi 1.18"$
$\phi 1.0"/\phi 0.98"$ $\phi 0.897"$
E3000 - 80,000rpm
E4000
3
MA
$\phi 0.897"$
$\phi 1.0"/\phi 0.98"$
$\phi 1.18"$
MS
$\phi 0.75"/\phi 0.79"$
$\phi 0.87"/\phi 0.91"$
$\phi 1.0"/\phi 0.98"$
4
HES
HTS
HPS
PLANET
Xpeed
ABT
5
AIR LINE KIT
6
PARTS
7
TECHNICAL DATA
8
APPLICATION EXAMPLES
INDEX

"Emax EVolution" & "ROTUS" ATTACHMENTS & ACCESSORIES

CAT. No. RE10182 90°ANGLE ATTACHMENT IC-300



35,000 min⁻¹(rpm) Max. (*1)
20,000 min⁻¹(rpm) Max. (*2)

Drive Motor & Controller

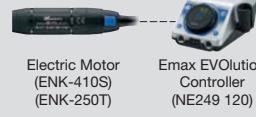

Electric Motor
(ENK-410S)
(ENK-250T)
Page 1-p7



Emax EVolution
Controller
(NE249 120)
Page 1-p4

or

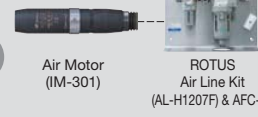

Air Motor
(IM-301)
Page 1-p33

ROTUS
Air Line Kit
(AL-H1207F) & AFC-45
Page 5-p2

- 90° Angle attachment with $\phi 1/8"$ ($\phi 3.175$ mm) Collet. Most suitable for polishing flat surfaces, corners and internal surfaces of pipes with paper disk mounted on rubber pad.

- Reduction Ratio : 3/4
- Weight : 1.59 oz.
- Collet
- Standard Size : $\phi 1/8"$ (CHC-3.175)
- Optional Collets : CHC-□□ are shown in page (6-p2)



90° Angle Attachment *Please use it with Speed Reducer. (ROTUS Air Motor)

CAT. No.	Model	Standard Accessories	Price
RE10182	IC-300	<ul style="list-style-type: none"> • Collet $\phi 1/8"$ (CHC-3.175) : 1 pc. • Standard Accessories : 1 set • Chuck Wrench (K-231) : 1 pc. • Pin Wrench (K-233) : 1 pc. 	228.00

CAT. No. RE10266 50°ANGLE ATTACHMENT KC-300



35,000 min⁻¹(rpm) Max. (*1)
20,000 min⁻¹(rpm) Max. (*2)

Drive Motor & Controller

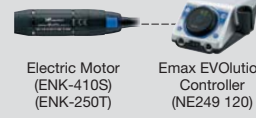

Electric Motor
(ENK-410S)
(ENK-250T)
Page 1-p7



Emax EVolution
Controller
(NE249 120)
Page 1-p4

or

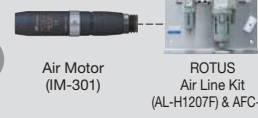

Air Motor
(IM-301)
Page 1-p33

ROTUS
Air Line Kit
(AL-H1207F) & AFC-45
Page 5-p2

- Ideal for the work at 50° angle, especially corners and deep concaves.

- Use the motor in reverse rotation for clockwise rotation.
- Speed Reduction Ratio : 3/4
- Weight : 1.59 oz.
- Collet
- Standard Size : $\phi 1/8"$ (CHC-3.175)
- Optional Collets : CHC-□□ are shown in page (6-p2)



50° Angle Attachment *Please use it with Speed Reducer. (ROTUS Air Motor)



CAT. No.	Model	Standard Accessories	Price
RE10266	KC-300	<ul style="list-style-type: none"> • Collet $\phi 1/8"$ (CHC-3.175) : 1 pc. • Standard Accessories : 1 set • Chuck Wrench (K-231) : 1 pc. • Pin Wrench (K-233) : 1 pc. 	228.00

Standard Accessories for IC-300 and KC-300



Description	CAT. No.	Model	O.D.	Grits	Q'ty
Rubber Pad	(Small)	RE11915	$\phi 10$ mm ($\phi 0.39"$)	-	1
	(Med)	RE11916	$\phi 20$ mm ($\phi 0.79"$)	-	1
	(Large)	RE11917	$\phi 30$ mm ($\phi 1.18"$)	-	1
Sandpaper Disk	LS10904	S-018	$\phi 11$ mm ($\phi 0.43"$)	# 180	5
	LS10910	S-060	$\phi 11$ mm ($\phi 0.43"$)	# 600	5
	RE11804	M-018	$\phi 21$ mm ($\phi 0.83"$)	# 180	5
	RE11810	M-060	$\phi 21$ mm ($\phi 0.83"$)	# 600	5
	RE11904	L-018	$\phi 31$ mm ($\phi 1.22"$)	# 180	5
RE11910	L-060	$\phi 31$ mm ($\phi 1.22"$)	# 600	5	

Optional Accessories for IC-300 and KC-300

Rubber Pad

Product	Description	CAT. No.	Model	O.D.	Grits	package	Price
	Rubber Pad (Small)	RE11915	—	ø10 mm (ø0.39")	—	1 pc./pack	5.00
	Rubber Pad (Med)	RE11916	—	ø20 mm (ø0.79")	—	1 pc./pack	5.00
	Rubber Pad (Large)	RE11917	—	ø30 mm (ø1.18")	—	1 pc./pack	5.00

Sandpaper Disk (Paper Type for Metals, Adhesive Back)

Product	Description	CAT. No.	Model	O.D.	Grits	package	Price
	Sandpaper Disk for small pad	LS10900	S-008	ø11 mm (ø0.43")	# 80	100 pcs./pack	15.00
		LS10902	S-012		# 120		
		LS10904	S-018		# 180		
		LS10905	S-024		# 240		
		LS10906	S-032		# 320		
		LS10908	S-040		# 400		
		LS10910	S-060		# 600		
		LS10912	S-080		# 800		
		LS10914	S-100		#1,000		
LS10915	S-150	#1,500					
	Sandpaper Disk for med. pad	RE11800	M-008	ø21 mm (ø0.83")	# 80	100 pcs./pack	25.00
		RE11802	M-012		# 120		
		RE11804	M-018		# 180		
		RE11805	M-024		# 240		
		RE11806	M-032		# 320		
		RE11808	M-040		# 400		
		RE11810	M-060		# 600		
		RE11812	M-080		# 800		
		RE11814	M-100		#1,000		
RE11815	M-150	#1,500					
	Sandpaper Disk for large pad	RE11900	L-008	ø31 mm (ø1.22")	# 80	100 pcs./pack	28.00
		RE11902	L-012		# 120		
		RE11904	L-018		# 180		
		RE11905	L-024		# 240		
		RE11906	L-032		# 320		
		RE11908	L-040		# 400		
		RE11910	L-060		# 600		
		RE11912	L-080		# 800		
		RE11914	L-100		#1,000		
RE11925	L-150	#1,500					

1
EmaxEVO
ESPERT
ROTUS
IMPULSE
PRESTO II
SHEENUS neo
SONIC CUTTER
2
iSpeed3
E2280 ø1.0"/ø0.98"
E2280 ø0.897"
E3000 — One Piece
E3000 — Modular
ø1.18"
ø1.0"/ø0.98"
ø0.897"
E3000 — 80,000rpm
E4000
3
MA
ø0.897"
ø1.0"/ø0.98"
ø0.897"
MS
ø0.75"
ø0.79"
ø0.87"
ø0.91"
ø1.0"/ø0.98"
ø0.897"
4
HES
HTS
HPS
PLANET
Xpeed
ABT
5
AIR LINE KIT
6
PARTS
7
TECHNICAL DATA
8
APPLICATION EXAMPLES
INDEX

"Emax EVolution" & "ROTUS" ATTACHMENTS

The Features of LUSTER ^{Emax}EVolution NLS-110 (Built-in Motor)

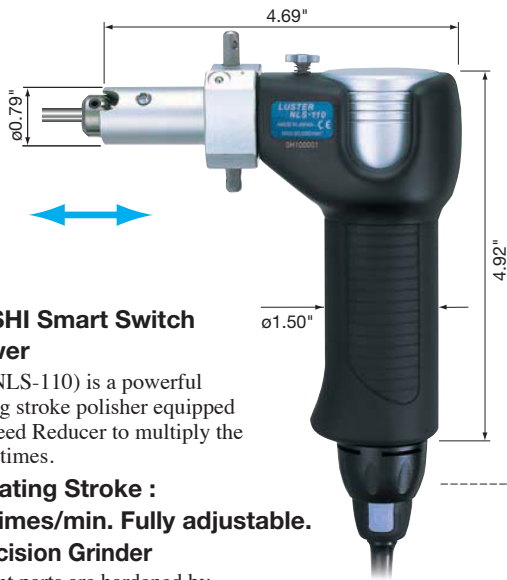

- **NAKANISHI Smart Switch**
- **High Power**
LUSTER (NLS-110) is a powerful reciprocating stroke polisher equipped with 1/4 Speed Reducer to multiply the torque by 4 times.
- **Reciprocating Stroke : 0~7,600 times/min. Fully adjustable.**

- **Ultra-Precision Grinder**
All important parts are hardened by heat treatment to provide excellent durability.
- **Designed with comfortable rubber-grip**

Well balanced, rubber-grip absorbs vibration from reciprocating strokes reducing fatigue and allowing long, continuous operation.



- **Stroke Range : 0~6 mm adjustable by stroke cam**

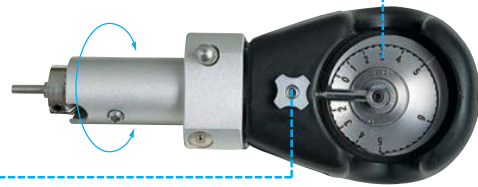

- **The tilt angle of grindstone arbor is adjustable.**
The grinding surface can be set at any angle between 0 and 360° enabling grinding of bottom, right, left and top surfaces without moving the machine itself.

Controller



- Weight : 1 lb. 12.22 oz. (w/o cord)
- Max. tool shank diameter ø0.25", Screw clamp type.
- Various types of attachment tools are provided as standard accessories.

Reciprocating Motion Polishing Finisher LUSTER

CAT. No.	Model	Standard Accessories	Price
1483	NLS-110	<ul style="list-style-type: none"> • Standard Accessories : 1 set • Allen Wrench (2 mm), (3 mm) : 1 pc. each • Lubrication Oil • Lubrication Nozzle for LUSTER 	1,648.00

30,000 min⁻¹(rpm) Max. (*1) 30,000 min⁻¹(rpm) Max. (*2)

The Features of LUSTER LS-100



- **High Power**
LUSTER (LS-100) is a powerful reciprocating stroke polisher.
- **Reciprocating Stroke : 0~7,600 times/min. Fully adjustable.**

- **Ultra-Precision Grinder**
All important parts are hardened by heat treatment to provide excellent durability.
- **Designed with comfortable rubber-grip**

Well balanced, rubber-grip absorbs vibration from reciprocating strokes reducing fatigue and allowing long, continuous operation.



- **Stroke Range : 0~6 mm adjustable by stroke cam**

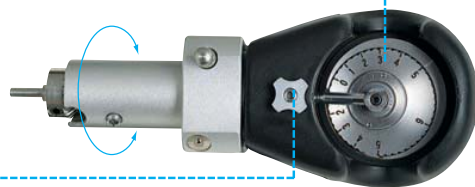

- **The tilt angle of grindstone arbor is adjustable.**
The grinding surface can be set at any angle between 0 and 360° enabling grinding of bottom, right, left and top surfaces without moving the machine itself.

Drive Motor & Controller



- Weight : 1 lb. 7.99 oz.
- Max. tool shank diameter ø0.25", Screw clamp type.
- Various types of attachment tools are provided as standard accessories.

Reciprocating Motion Miniature Polisher LUSTER

CAT. No.	Model	Standard Accessories	Price
LS10815	LS-100	<ul style="list-style-type: none"> • Standard Accessories : 1 set • Allen Wrench (2 mm), (3 mm) : 1 pc. each • Lubrication Oil • Lubrication Nozzle for LUSTER 	862.00

30,000 min⁻¹(rpm) Max. (*1) 30,000 min⁻¹(rpm) Max. (*2)

1

EmaxVO

ESPERT

ROTUS

IMPULSE

PRESTO II

SHEENUS neo

SONIC CUTTER

2

iSpeed3

E2280

ø1.0"/ø0.98"

E2280

ø0.897"

E3000

- One Piece

E3000

- Modular

ø1.18"

ø1.0"/ø0.98"

ø0.897"

E3000

- 80,000rpm

E4000

3

MA

ø0.897"

ø1.0"/ø0.98"

ø1.18"

MS

ø0.75"/ø0.79"

ø0.87"/ø0.91"

ø1.0"/ø0.98"

ø1.18"

4

HES

HTS

HPS

PLANET

Xpeed

ABT

5

AIR LINE KIT

6

PARTS

7

TECHNICAL DATA

8

APPLICATION EXAMPLES

INDEX

The Features of MINI-LUSTER ML-8



- Reciprocating Stroke (variable) : Approx 0~9,000 times/min.
- Stroke Range (fixed) : 0.8 mm.
- Due to pencil type grip, it is most suitable for polishing narrow grooves, details, etc.
- Lightweight, compact design and minimal vibration keep the hand free from fatigue for long continuous operation.
- By using the grindstone holder provided, various tools such as oil stone, super stone, diamond files, etc. can be used.



Drive Motor & Controller

 Electric Motor (ENK-410S) (ENK-250T) Page 1-p7	or	 Air Motor (IM-301) ROTUS Air Line Kit (AL-H1207F) & AFC-45 Page 1-p33
---	----	---

- Weight : 5.12 oz.
- Max. tool shank diameter $\phi 0.13"$, Screw clamp type.
- Various attachment tools and holders are provided as standard accessories.

Pencil-Type Reciprocating Polishing Finisher MINI-LUSTER Attachment

CAT. No.	Model	Stroke Range	Standard Accessories	Price
LS51307	ML-8	0.8mm	<ul style="list-style-type: none"> • Allen Wrench (1.5 mm) : 1 pc. • Standard Accessories : 1 set 	624.00

35,000 min⁻¹(rpm) Max. (*1) 30,000 min⁻¹(rpm) Max. (*2)

The Features of SWING-LUSTER SLS-16



- High speed grinding and polishing operations can be performed while maintaining the fine and delicate feeling of hand polishing.
- Lightweight pencil type design makes it easy to work in tight areas.
- Ergonomically designed to provide high sensitivity for precision work.
- Easily adjustable stroke length allows efficient work on minute areas or large sections.

- Weight : 5.00 oz.
- Reciprocating Stroke (variable) : 0~9,000 times/min
- Stroke range (variable) : 0~1.6 mm
- Max. tool shank diameter $\phi 0.20"$, Screw clamp type.

Drive Motor & Controller

 Electric Motor (ENK-410S) (ENK-250T) Page 1-p7	or	 Air Motor (IM-301) ROTUS Air Line Kit (AL-H1207F) & AFC-45 Page 1-p33
---	----	---

Pencil-Type Reciprocating Polishing Finisher SWING-LUSTER Attachment

CAT. No.	Model	Standard Accessories	Price
LS11380	SLS-16	<ul style="list-style-type: none"> • Wrench (16 x 18), (20 x 24) : 1 pc. each • Allen Wrench (1.5 mm) : 1 pc. • Standard Accessories : 1 set 	624.00

35,000 min⁻¹(rpm) Max. (*1) 24,000 min⁻¹(rpm) Max. (*2)

*Please use it with Speed Reducer. (ROTUS Air Motor)

1
EmaxEVO
ESPERT
ROTUS
IMPULSE
PRESTO II
SHEENUS neo
SONIC CUTTER
2
iSpeed3
E2280 $\phi 1.07"/\phi 0.98"$
E2280 $\phi 0.897"$
E3000 - One Piece
E3000 - Modular
$\phi 1.18"$
$\phi 1.07"/\phi 0.98"$ $\phi 0.897"$
E3000 - 80,000rpm
E4000
3
MA
$\phi 0.897"$
$\phi 1.07"/\phi 0.98"$
$\phi 1.18"$
MS
$\phi 0.75"/\phi 0.79"$
$\phi 0.87"/\phi 0.91"$
$\phi 1.07"/\phi 0.98"$
4
HES
HTS
HPS
PLANET
Xpeed
ABT
5
AIR LINE KIT
6
PARTS
7
TECHNICAL DATA
8
APPLICATION EXAMPLES
INDEX

"Emax EVOLUTION" & "ROTUS" ACCESSORIES

1

EmaxEVO

ESPERT

ROTUS

IMPULSE

PRESTO II

SHEENUS neo

SONIC CUTTER

2

iSpeed3

E2280

E2280

E3000

E3000

E3000

E3000

E4000

3

MA

MS

MS

MS

MS

MS

MS

MS

4

HES

HTS

HPS

PLANET

Xpeed

ABT

5

AIR LINE KIT

6

PARTS

7

TECHNICAL DATA











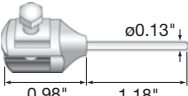

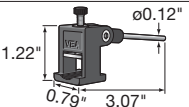



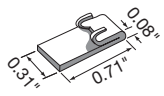

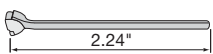
8

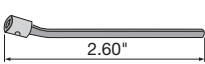
APPLICATION EXAMPLES

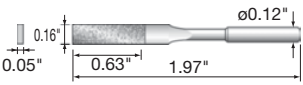
INDEX

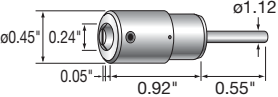
Tool and standard accessories for LUSTER, MINI-LUSTER, SWING-LUSTER

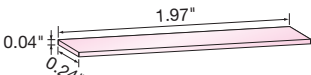
• Each product is provided with tool  as standard.

Product	Model	CAT. No.	Price (Package)	LUSTER NLS-110 / LS-100 ELS-100	MINI-LUSTER ML-8 / EML-8	SWING-LUSTER SLS-16
Max. clampable size : Thickness 0.18" x width 0.43" 	Grindstone Holder VES	LS10875	32.00 (1 pc./pack)	 (1 pc.)		
Max. clampable size : Thickness 0.43" x width 0.53" 	Grindstone Holder VEA	LS10834	43.00 (1 pc./pack)	 (1 pc.)		
[4] 	Tool Holder with Spring FVA	LS10867	32.00 (1 pc./pack)	 (1 pc.)	 (1 pc.)	
[1] 	Rectangular Pad LKE-2A	LS10891	15.00 (1 pc./pack)	 (1 pc.)		
[2] 	Rod for Rectangular Pad FBA-2	LS10848	16.00 (1 pc./pack)	 (1 pc.)		
[3] 	Angle Rod NGA	LS10853	15.00 (1 pc./pack)	 (1 pc.)		
	Diamond Grindstone DLA4 x 1-100	LS10918	37.00 (1 pc./pack)		 (1 pc.)	 (1 pc.)
Max. clampable size : Thickness 0.04" x width 0.24" 	Ceramic Fiber Grindstone Holder	62510	37.00 (1 pc./pack)		 (1 pc.)	 (1 pc.)
	Ceramic Fiber Grindstone (#1,200)	60737	41.00 (2 pcs./pack)		 (1 pc.)	 (1 pc.)

● Illustration Usage

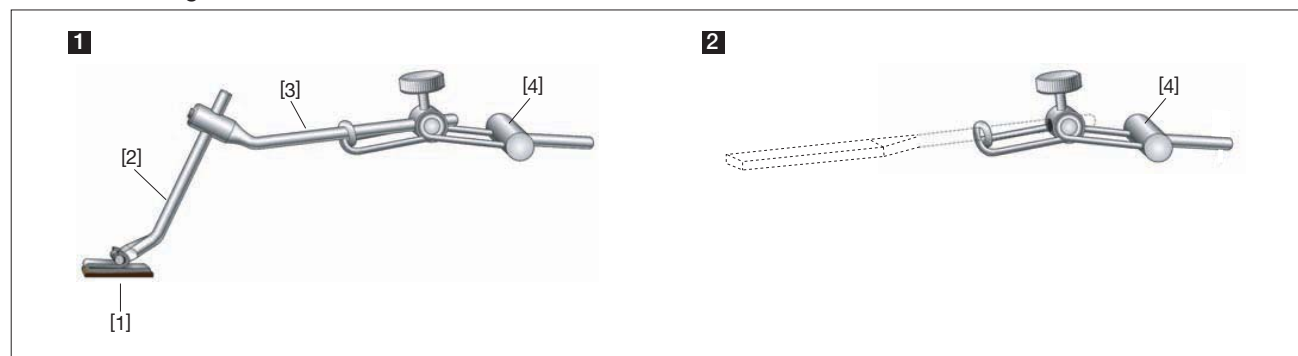

AMERICAN ROTARY TOOLS CO. Toll Free US & CA +1 (800) 645-3824

- 1** EmaxEVO
- ESPERT
- ROTUS**
- IMPULSE
- PRESTO II
- SHEENUS neo
- SONIC CUTTER
- 2** iSpeed3
- E2280 ø1.0"/ø0.98"
- E2280 ø0.897"
- E3000 - One Piece
- E3000 - Modular ø1.18"
- ø1.0"/ø0.98" ø0.897"
- E3000 - 80,000rpm
- E4000
- 3** MA ø0.897"
- ø1.0"/ø0.98" ø1.18"
- MS ø0.75"/ø0.79"
- ø0.87"/ø0.91"
- ø1.0"/ø0.98"
- 4** HES
- HTS
- HPS
- PLANET
- Xpeed
- ABT
- 5** AIR LINE KIT
- 6** PARTS
- 7** TECHNICAL DATA
- 8** APPLICATION EXAMPLES
- INDEX

The Features of HA-500



Drive Motor & Controller

 Electric Motor (ENK-410S) (ENK-250T) Page 1-p7	or	 Air Motor (IM-301) ROTUS Air Line Kit (AL-H1207F) & AFC-45 Page 1-p33 Page 5-p2
---	----	--

- Stroke speed : 25~5,000 strokes/min
- A wide variety of patterns can be produced by varying the spring pressure and hammer speed.
- Light weight, pencil type grip makes the handpiece very comfortable to hold and easy to use.
- Adjustable spring pressure.
- Self lubricating hammer mechanism ensure excellent durability.

Engraving and Ornament Processing Work Hammer Attachment

CAT. No.	Model	Standard Accessories	Price
RE18060	HA-500	<ul style="list-style-type: none"> • Wrench (7 x 5.5) : 1 pc. • Bar Wrench (K-212) : 1 pc. • Oil and Oil offer machine • Hammer Bit (For replacement) : 2 pcs. 	607.00

20,000 min⁻¹(rpm) Max. (*1) 16,000 min⁻¹(rpm) Max. (*2)
 *Please use it with Speed Reducer. (ROTUS Air Motor)

Hammer Bit to be machined to required shapes (SUS-420, heat treated, approx, HRC50)

Product	CAT. No.	Package	Price
	RE65301	3 pcs./pack	50.00

- Weight : 3.35 oz.
- Stroke range : 0.4 mm • Stroke Spring Pressure : 4.4~7.1N (Ring Adjustment Type)

The Features of FINE BELT SANDER KBS-101

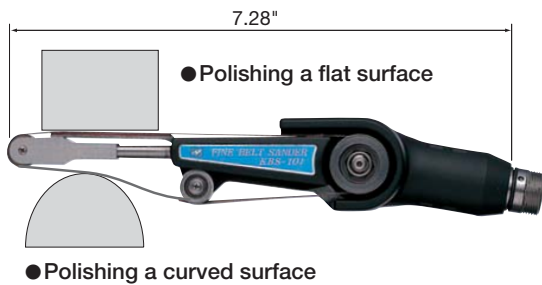

Drive Motor & Controller

 Electric Motor (ENK-410S) (ENK-250T) Page 1-p7	or	 Air Motor (IM-301) ROTUS Air Line Kit (AL-H1207F) & AFC-45 Page 1-p33 Page 5-p2
---	----	--

- Belt runs Approx. 0~2,700 ft/min
- 8 mm, 6 mm and 4 mm width belts are available.
- The angle of the belt section is fully adjustable.
- Exchanging the belt is simply done by lever release.
- Weight : 12.35 oz.
- Light-weight, compact, minimal vibration and a small diameter grip design keep the hand free from fatigue for long, continuous operation.
- When polishing a curved surface, the tension between the front and central pulley can be utilized. When polishing a flat surface or a groove, use the flat part of belt.







FINE BELT SANDER Attachment

CAT. No.	Model	Standard Accessories	Price
KBS61065	KBS-101	<ul style="list-style-type: none"> • 8 mm Belt (3 kinds 2 pcs. each) • 6 mm Belt (3 kinds 2 pcs. each) • 4 mm Belt (3 kinds 2 pcs. each) • Allen Wrench (3 mm) : 1 pc. 	612.00

35,000 min⁻¹(rpm) Max. (*1) 35,000 min⁻¹(rpm) Max. (*2)

Belt for FINE BELT SANDER (Ring Type)

Product	Description	CAT. No.	Grit	Width (mm)	Length (mm)	Package	Price (Package)		
	Sand Belt	64901	# 80	4	300	30 pcs./pack	35.00		
		64902	# 120						
		64903	# 180						
		64904	# 240						
		64905	# 320						
		64906	# 400						
		64911	# 80	6					
		64912	# 120						
		64913	# 180						
		64914	# 240						
		64915	# 320						
		64916	# 400						
		64921	# 80	8					
		64922	# 120						
		64923	# 180						
		64924	# 240						
		64925	# 320						
		64926	# 400						
		64927	# 600						
64928	# 800								
Sand Belt for Wood	64941	# 80							
	64942	# 120							
	64943	# 240							
	Zirconia Belt	64971	# 80	8	300	30 pcs./pack	37.00		
	Diamond Belt (Hard Type)	64972	# 100	8	300	3 pcs./pack	69.00		
		64973	# 120						
		65011	# 80						
		65012	# 120						
		65017	# 600						
	Diamond Belt (Soft Type)	65021	# 120	8	300	3 pcs./pack	52.00		
		65022	# 180						
		65023	# 240						
		65024	# 320						
		65025	# 600	8			300	3 pcs./pack	47.00
		65026	# 800						
		65027	#1,000						
	Felt Belt	65101	—	8	300	5 pcs./pack	35.00		

"Emax EVOLution" & "ROTUS" SPEED REDUCER & PARTS

1

EmaxEVO

ESPERT

ROTUS

IMPULSE

PRESTO II

SHEENUS neo

SONIC CUTTER

2

iSpeed3

E2280

ø1.0"/ø0.98"

E2280

ø0.897"

E3000

- One Piece

E3000

- Modular

ø1.18"

ø1.0"/ø0.98"

ø0.897"

E3000

- 80,000rpm

E4000

3

MA

ø0.897"

ø1.0"/ø0.98"

ø1.18"

4

HES

HTS

HPS

PLANET

Xpeed

ABT

5

AIR LINE KIT

6

PARTS

7

TECHNICAL DATA

8

APPLICATION EXAMPLES

INDEX

CAT. No. R010214 SPEED REDUCER RG-01



TORQUE UP 4 TIMES
(1/4 Speed Reducer)

● The speed is reduced to 1/4 but the torque is multiplied by 4 times.

- Weight : 2.40 oz.
- 30,000 min⁻¹(rpm) Max. (*1) 30,000 min⁻¹(rpm) Max. (*2)

Speed Reducer (1/4)

CAT. No.	Model	Standard Accessories	Price
R010214	RG-01	• Pin Wrench (K-233) : 1 pc.	127.00

CAT. No. R010228 SPEED REDUCER RG-02



TORQUE UP 15 TIMES
(1/15 Speed Reducer)

● The speed is reduced to 1/15 but the torque is multiplied by 15 times.

- Weight : 3.28 oz.
- 30,000 min⁻¹(rpm) Max. (*1) 30,000 min⁻¹(rpm) Max. (*2)

Speed Reducer (1/15)

CAT. No.	Model	Standard Accessories	Price
R010228	RG-02	• Pin Wrench (K-233) : 1 pc.	159.00

CAT. No. RE10210 EXTENSION JOINT CN-01



(Speed 1 : 1)

● This is a joint to be connected between a motor and an attachment to extend the total length of the attachment.

- Weight : 2.93 oz.
- 35,000 min⁻¹(rpm) Max. (*1) 35,000 min⁻¹(rpm) Max. (*2)

Extension Joint (Speed 1 : 1)

CAT. No.	Model	Standard Accessories	Price
RE10210	CN-01	• Pin Wrench (K-233) : 1 pc.	75.00

CAT. No. 8106 FOOT PEDAL FC-64



● Used as an ON/OFF switch as well as a variable speed control.

Foot Pedal





CAT. No.	Model	Fit to	Price
8106	FC-64	Emax EVOLution (NE249)	102.00

AMERICAN ROTARY TOOLS CO.

www.artcotools.com

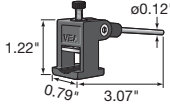
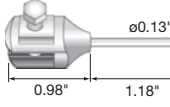
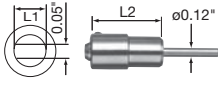
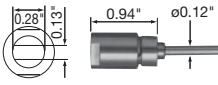
"Emax EVOLution" & "ROTUS" ACCESSORIES

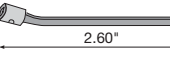
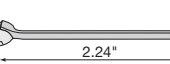
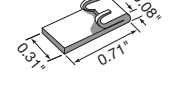

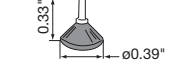
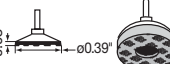
Common Tools for LUSTER, MINI-LUSTER

Product	CAT. No.	Description · Model	Price
	LS 10834	Grindstone Holder VEA for (W 0.53" x T 0.43")	43.00
	LS 10875	Grindstone Holder VES for (W 0.43" x T 0.18")	32.00
	ZO 94005 94006 94007	Holder for Super Stone SH-10 (L1=0.40" (L2=1.10") SH-6 (L1=0.24" (L2=0.92") SH-4 (L1=0.16" (L2=0.87")	32.00 *1
	ZO 95008	Oil Stone Lapping Stick Holder for (W 0.24" x T 0.12")	32.00
[4] 	LS 10867	Tool Holder with Spring FVA	32.00
[3] 	LS 10853	Angle Rod NGA	15.00
[2] 	LS 10848	Rod for Lapping FBA-2	16.00
[1] 	LS 10891	LKE-2A with Hinge Use with FBA-2	15.00
[1] 	LS 11326	Hinge (Diamond) DLC-7 x 18-100	38.00 *2
	LS 10886	Ball Joint LAA-3A Use with SEV	18.00 *2
	LS 11327	Ball Joint (with Diamond) DLD-10/0.75	37.00 *2

[1]-[4] : Please See Page 1-p14 for Illustration Usage.

*1 : Other than noted, prices are per piece.

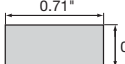
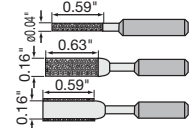
*2 : Available while supply lasts. Check with NSK America.

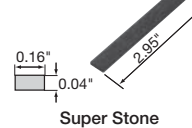
Product	CAT. No.	Description · Model	Price
	LS10900	S-008 # 80	100 pcs. Package 15.00
	LS10902	S-012 # 120	
	LS10904	S-018 # 180	
	LS10905	S-024 # 240	
	LS10906	S-032 # 320	
	LS10908	S-040 # 400	
	LS10910	S-060 # 600	
	LS10912	S-080 # 800	
	LS10914	S-100 # 1,000	
	LS10915	S-150 # 1,500	
	LS10919	K-012 # 120	100 pcs. Package 28.00
	LS10921	K-018 # 180	
	LS10923	K-032 # 320	
	LS10927	K-060 # 600	
	LS10929	K-080 # 800	
	LS10931	K-100 # 1,000	
	LS10932	K-150 # 1,500	
	LS10963	DLA-1-100	28.00
	LS10918	DLA4 x 1-100	37.00
	LS10922	DLA1 x 4-100	30.00
	LS26712	Black # 600 *2	54.00
	LS26707	Blue # 800 *2	
	LS26708	White # 1,000 *2	
	LS26709	Red # 1,200 *2	
	LS26711	Black # 600 *2	41.00
	LS26704	Blue # 800 *2	
	LS26705	White # 1,000 *2	
	LS26706	Red # 1,200 *2	
	LS26710	Black # 600 *2	
LS26701	Blue # 800 *2		
LS26702	White # 1,000 *2		
	LS26703	Red # 1,200 *2	21.00

1
EmaxEVO
ESPERT
ROTUS
IMPULSE
PRESTO II
SHEENUS neo
SONIC CUTTER
2
iSpeed3
E2280
E2280
E2280
E3000
E3000
E3000
E3000
E4000
3
MA
MS
MS
MS
MS
4
HES
HTS
HPS
PLANET
Xpeed
ABT
5
AIR LINE KIT
6
PARTS
7
TECHNICAL DATA
8
APPLICATION EXAMPLES
INDEX

CHA Group

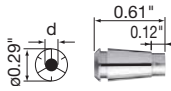

Model :
CHA-1.0,
CHA-3.0, CHA-3.0AA,
CHA-3.175, CHA-3.175AA,
CHA-4.0, CHA-4.0AA

Fit to : K-263
: CHN-A

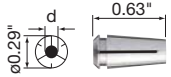

Model :
Besides the above

Fit to

AMS-1200 · AMS-1210 · AMS-1500 · AMS-1501 · AMS-250 · ABS-800 · iSpeed3
MS-19 · 20 · 22 · MSS-19 · 20 · 22 · NR-3080S · NRA-5080 · NR-320
PS20-70/120 · PS20S-70 · PSA23-80/130 · PSA23S-80 · PMS-3020A · BANTAM 250
PLANET 850 · PLANET 1500 · PLANET 2000 · SMS · HTS · EM20-S6000 · EM25-S6000
EMS-3060A · NR3060-AQC · NRR3060-QC · HES810 · HPS500 · Xspeed1600 · ABT-1000

CAT. No.	Model	Inside Diameter d	Price
91405	CHA-0.5	ø0.5	237.00
91406	CHA-0.6	ø0.6	
91407	CHA-0.7	ø0.7	
RA11805	CHA-0.8	ø0.8	83.00
RA11804	CHA-0.9	ø0.9	
RA11806	CHA-1.0	ø1.0	106.00
RA11807	CHA-1.1	ø1.1	
RA11808	CHA-1.2	ø1.2	
RA11803	CHA-1.3	ø1.3	
RA11815	CHA-1.4	ø1.4	
RA11814	CHA-1.5	ø1.5	83.00
RA11809	CHA-1.6	ø1.6	71.00
91417	CHA-1.7	ø1.7	106.00
RA11810	CHA-1.8	ø1.8	
RA11822	CHA-1.9	ø1.9	
RA11811	CHA-2.0	ø2.0	83.00
RA11831	CHA-2.1	ø2.1	106.00
91422	CHA-2.2	ø2.2	
91423	CHA-2.3	ø2.3	
RA11812	CHA-2.35	ø2.35	71.00
RA11824	CHA-2.4	ø2.4	106.00
RA11821	CHA-2.5	ø2.5	83.00
RA11826	CHA-2.6	ø2.6	106.00
91427	CHA-2.7	ø2.7	
RA11828	CHA-2.8	ø2.8	
RA11829	CHA-2.9	ø2.9	71.00
RA11813	CHA-3.0	ø3.0	
91494	CHA-3.0AA*	ø3.0	123.00
RA11830	CHA-3.1	ø3.1	106.00
RA11818	CHA-3.175	ø1/8"	71.00
91496	CHA-3.175AA*	ø1/8"	123.00
91432	CHA-3.2	ø3.2	106.00
91433	CHA-3.3	ø3.3	
91434	CHA-3.4	ø3.4	
RA11823	CHA-3.5	ø3.5	83.00
91436	CHA-3.6	ø3.6	106.00
91437	CHA-3.7	ø3.7	
91438	CHA-3.8	ø3.8	
91439	CHA-3.9	ø3.9	83.00
RA11819	CHA-4.0	ø4.0	
91495	CHA-4.0AA*	ø4.0	123.00

CHB Group

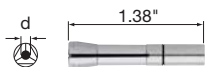

Fit to

NRR-2651 · NRR-3060 · NR40-5100 ATC

CAT. No.	Model	Inside Diameter d	Price
92820	CHB-2.0	ø2.0	89.00
92830	CHB-3.0	ø3.0	
92893	CHB-3.175	ø1/8"	
92840	CHB-4.0	ø4.0	

CHC Group

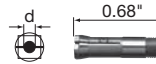

Fit to

IC-300 · KC-300 · EIC-300 · EKC-300 · IC-E · KC-E

CAT. No.	Model	Inside Diameter d	Price
90416	CHC-1.6	ø1.6	78.00
90492	CHC-2.35	ø2.35	59.00
90430	CHC-3.0	ø3.0	
90493	CHC-3.175	ø1/8"	

CHF Group

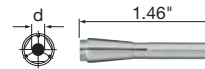

Fit to

NR-3080

CAT. No.	Model	Inside Diameter d	Price
91730	CHF-3.0	ø3.0	83.00
91793	CHF-3.175	ø1/8"	

CHG Group

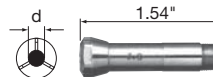

Fit to

HG-200 · NR-301 · EHG-400

Fit to

NR-301

CAT. No.	Model	Inside Diameter d	Price
RA11777	CHG-1.0	ø1.0	83.00
RA11778	CHG-1.5	ø1.5	
RA11766	CHG-1.6	ø1.6	78.00
RA11780	CHG-2.0	ø2.0	83.00
RA11771	CHG-2.35	ø2.35	71.00
RA11781	CHG-2.5	ø2.5	83.00
RA11772	CHG-3.0	ø3.0	71.00
RA11452	CHG-3.175	ø1/8"	
RA11697	CHG-4.0	ø4.0	78.00
RA11698	CHG-4.76	ø4.76	83.00
RA11709	CHG-5.0	ø5.0	71.00
RA11773	CHG-6.0	ø6.0	
RA11714	CHG-6.35	ø1/4"	

CHH Group



Fit to

IH-300 · IR-310 · EHL-401 · EHR-401 · EHR-500 · VH-E

CAT. No.	Model	Inside Diameter d	Price
RE11729	CHH-1.0	ø1.0	71.00
90615	CHH-1.5	ø1.5	
RE11659	CHH-1.6	ø1.6	
RE11734	CHH-2.0	ø2.0	59.00
RE11625	CHH-2.35	ø2.35	
90625	CHH-2.5	ø2.5	71.00
RE11739	CHH-3.0	ø3.0	59.00
RE11630	CHH-3.175	ø1/8"	

CHM Group

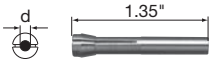

- Fit to _____
MH-300 · BMH-300
- Fit to _____
NR-600 · NR-601 · AMH-300 · AMH-301

CAT. No.	Model	Inside Diameter d	Price
RE11605	CHM-1.0	ø1.0	71.00
RE11600	CHM-1.6	ø1.6	
RE11609	CHM-2.0	ø2.0	
RE11602	CHM-2.35	ø2.35	59.00
RE10459	CHM-3.0	ø3.0	
RE11604	CHM-3.175	ø1/8"	

CHP Group

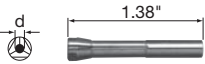

- Fit to _____
ENR-420 ATC
- Fit to _____
NRR-2650 · NR-260E ATC

CAT. No.	Model	Inside Diameter d	Price
AS72115	CHP-2.0	ø2.0	83.00
AS72116	CHP-3.0	ø3.0	71.00
AS72117	CHP-3.175	ø1/8"	

CHR Group

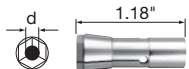

- Fit to _____
NR-5040E ATC · NR-5041E ATC · NR50-5100 ATC

CAT. No.	Model	Inside Diameter d	Price
91920	CHR-2.0	ø2.0	89.00
91930	CHR-3.0	ø3.0	78.00
91993	CHR-3.175	ø1/8"	
91940	CHR-4.0	ø4.0	
91960	CHR-6.0	ø6.0	89.00
91996	CHR-6.35	ø1/4"	

CHR RS Group



- Fit to _____
NR-5040E ATC · NR-5041E ATC · NR50-5100 ATC-RS

CAT. No.	Model	Inside Diameter d	Price
93201	CHR-3.0 RS	ø3.0	120.00
93202	CHR-3.175 RS	ø1/8"	
93203	CHR-4.0 RS	ø4.0	
93204	CHR-6.0 RS	ø6.0	
93205	CHR-6.35 RS	ø1/4"	

CHS Group

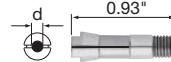

- Fit to _____
ERA-270 · IMPULSE SERIES
- Fit to _____
RA-200 · RA-271E · RA-2521 · RA-H2521

CAT. No.	Model	Inside Diameter d	Price
NK10216	CHS-0.8	ø0.8	190.00
90509	CHS-0.9	ø0.9	
NK10218	CHS-1.0	ø1.0	59.00
90511	CHS-1.1	ø1.1	83.00
90512	CHS-1.2	ø1.2	
90513	CHS-1.3	ø1.3	
90514	CHS-1.4	ø1.4	
NK10219	CHS-1.5	ø1.5	
NK10220	CHS-1.6	ø1.6	48.00
90517	CHS-1.7	ø1.7	83.00
90518	CHS-1.8	ø1.8	
90519	CHS-1.9	ø1.9	
NK10221	CHS-2.0	ø2.0	59.00
90521	CHS-2.1	ø2.1	83.00
90522	CHS-2.2	ø2.2	
90523	CHS-2.3	ø2.3	
NK10215	CHS-2.35	ø2.35	48.00
NK10224	CHS-2.4	ø2.4	83.00
NK10222	CHS-2.5	ø2.5	59.00
90526	CHS-2.6	ø2.6	83.00
90527	CHS-2.7	ø2.7	
90528	CHS-2.8	ø2.8	
NK10209	CHS-2.9	ø2.9	
NK10223	CHS-3.0	ø3.0	48.00
NK10210	CHS-3.175	ø1/8"	

CHSS Group

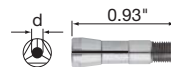

- Fit to _____
EMA-3020S · PMA-3013S

CAT. No.	Model	Inside Diameter d	Price
93010	CHSS-1.0	ø1.0	92.00
93015	CHSS-1.5	ø1.5	
93020	CHSS-2.0	ø2.0	
93092	CHSS-2.35	ø2.35	
93025	CHSS-2.5	ø2.5	
93030	CHSS-3.0	ø3.0	66.00
93093	CHSS-3.175	ø1/8"	