

MASTER COPY

Super

MHI

Copy 3

19-25 (1 Dec 71)

FM 19-25

DEPARTMENT OF THE ARMY TECHNICAL MANUAL

LOGISTICS LIBRARY BR, 12110

RECORDED
FOR INFORMATION ONLY

MILITARY POLICE TRAFFIC CONTROL

PROPERTY OF
QUARTERMASTER LIBRARY
S. ARMY QUARTERMASTER LIBRARY
FORT LEE, VA.



HEADQUARTERS, DEPARTMENT OF THE ARMY
OCTOBER 1964

HEADQUARTERS
DEPARTMENT OF THE ARMY
WASHINGTON, D.C., 20 June 1968

CHANGE }
No. 1 }

MILITARY POLICE TRAFFIC CONTROL

FM 19-25, 7 October 1964, is changed as follows:

Cover. "Department of the Army Technical Manual" is changed to read "Department of the Army Field Manual."

Page 1. Insert "7." before words "GENERAL CONTROL OPERATIONS."

Page 3, paragraph 2b. In line 5, "FM 55-31" is changed to read "FM 55-4-1 (TEST)."

Page 3. Paragraph 2c(3) is superseded as follows:

(3) Indigenous traffic consists of refugee and local civilian traffic and casual non-U.S. military movement. The presence of such unorganized traffic may require control measures to restore efficient use of the road net.

Page 5, paragraph 8. In line 9, "maneuver" is changed to read "movement."

Page 32, paragraph 36. In line 4, "patrol" is changed to read "point."

Page 38, figure 21. In box C of legend, "on direction of free flow" is changed to read "in direction of go flow."

Page 39, figure 22. In box C of legend, "on direction or free flow" is changed to read "in direction of go flow." In the left diagram, change the broken lines, indicating the direction in which the vehicles are turning, to solid lines. In the middle diagram change the left "A" to read "C." In the right diagram, change the "A's," at the top and bottom of the diagram making right turns, to read "C."

Page 42, paragraph 48c. In line 2, "tetrachloride" is changed to read "dioxide."

Page 43. Paragraph 49d is added as follows:

d. Nothing in the foregoing is intended as prohibiting the driving of the patrol vehicle by the senior military policeman for reasons of necessity or advisability. The "driver" may become incapacitated, or may require a relief to

prevent excessive fatigue. Local rules, necessity and good judgment should be the guides.

Page 43, paragraph 50a(1). In line 3, after "vehicle" insert "During the hours of darkness the parking lights, as a minimum, will be turned on."

Page 46, figure 24. In line 2, under category STOP, in the remarks column, "pass" is changed to read "past." In line 9, under category STOP, in explanation of offense column, "existing" is changed to read "exiting."

Page 49, paragraph 55b. In line 4, after "how" insert "well."

Page 55, paragraph 64b. In lines 16 and 17, change "Article 31 of the UCMJ" to read "AR 195-10."

Page 56. Figure 30 is Rescinded.

Page 56. Paragraph 69 is superseded as follows:

69. Approach to Violators Vehicle

a. The driver and MP passenger (rider) approach the violator's vehicle from the left and right rear respectively. The MP passenger stops at the right rear of the violator's vehicle, from which position he can observe the occupants of the vehicle and act as a protective cover man for the MP driver. The MP driver proceeds to the front edge of the driver's door, after checking the rear seat and floor, keeping the violator and occupants in sight at all times. While speaking to the violator, he should stand about 2 feet from the vehicle in line with the front edge of the driver's door, facing the violator. This position will prevent him from being struck by the door in the event it is suddenly opened and will allow him to observe the violator's movements and oncoming traffic.

b. In those situations where it is necessary to have the violator dismount, the military po-

liceman will open the driver's door, if traffic conditions allow, moving backwards with the swing of the door. The violator will move around the front of his vehicle, with the military policeman following, and will be directed to stand on the curb or sidewalk at the right front of his vehicle. If traffic conditions do not permit this procedure to be followed, have the violator exit on the curb side.

Pages 56 and 57, paragraph 70b. In line 3 after the word "stopped" the following is added "and the action to be taken (i.e., warning, citation, etc.)." In line 8 after the word "zone" the following is added "I am going to issue you an Armed Forces Traffic Ticket. May I see your driver's license and ID card (if applicable), please."

Page 57, paragraph 70c. In lines 6 beginning with "During this" the remainder of the subparagraph is deleted.

Page 57. Paragraph 70d is superseded as follows:

d. Extreme care must be exercised to insure that the rights of the traffic offender are not violated. The guidelines to follow are:

(1) Do not ask questions of the violator (i.e., Were you speeding; Why were you speeding; Didn't you see the stop sign, etc.).

(2) If it is necessary to ask questions, first warn the individual of his rights (AR 195-10).

(3) When the military policeman has reason to believe the violator is suspected of committing an offense, other than the traffic offense, immediately warn him of his rights (AR 195-10).

Page 57, paragraph 71a. In lines 5-8, "The military policeman informs the violator of the intended action, and proceeds to take that action" is deleted.

Page 60, paragraph 79a. In line 2, after "stages" the following is added "and in determining these, each traffic unit must be considered individually."

Page 62, paragraph 82d. In lines 8 and 9, "Article 31, Uniform Code of Military Justice will apply in many cases" is changed to read "AR 195-10 will apply."

Page 67, paragraph 83c(3). In lines 6 and 7, "To be valid, all tires must have made skid-marks," is deleted.

Page 74, paragraph 88f. In line 12, after "methods" the following is added: "Armed rotary-wing aircraft, working in conjunction with the ground escort vehicles, may provide added security to the movement."

Page 94, paragraph 107a. In lines 1 and 2, "Transportation Corps Function (FM 55-31)" is changed to read "transportation function (FM 55-4-1 (Test))."

Page 96, paragraph 111b. Subparagraphs (1) through (6) are deleted and the following is added:

(1) Forward-moving traffic has priority over traffic moving to the rear.

(2) Forward-moving loaded vehicles have priority over empty vehicles moving in any direction.

Page 103. Paragraph 127e is added as follows:

e. Nothing in the foregoing is intended as prohibiting the driving of the patrol vehicle by any member of the patrol for reasons of necessity or advisability.

Page 103, paragraph 128a. In lines 2 and 3, "¼-ton and ¾-ton vehilces" is changed to read "¼-ton, ¾-ton, and light armored vehicles."

Page 110, paragraph 140a. In line 4, after "environment" the following is added: "(para 87-89)."

Page 112, paragraph 143b(3). In (a) in line 3, "a" is changed to read "and." In (b) in line 1, "Army" is changed to read "Armored."

Page 112. Paragraph 143c is added as follows:

c. Armored escort vehicles may be used in place of wheeled vehicles for security operations described above. In addition, they may be dispersed throughout all sections of the convoy in order to provide added security. During an ambush action these vehicles have two important functions: first, they provide immediate protection for personnel caught in the killing zone by engaging the enemy at point-blank range and second, they provide direct fire support for the counterattack.

Page 113, paragraph 145b. In line 3, after "control" the following is added: "under the direction of the Nuclear Accident/Incident Control Officer (NAICO)."

Page 116, figure 58. On the right side of the lower symbol insert "1."

Page 118, figure 59. In Legend, before "automatic weapon" insert "1."

Page 128. Paragraph 169 is superseded as follows:

169. Far Side

On the far side, emphasis is on precision traffic control to prevent the massing of vehicles and to facilitate the maximum use of the existing road nets; therefore, military police must be present immediately following the assault units. This traffic control is then accomplished by TCP and motor patrols at holding areas and at critical crossroads or road junctions.

The following are added:

FM 3-10	Employment of Chemical and Biological Agents
FM 3-15	Nuclear Accident Contamination Control
FM 19-2-1 (Test)	Military Police Support, Field Army Support Command
FM 19-3-1 (Test)	Military Police Support, TASCOC
FM 19-15	Civil Disturbances and Disasters
FM 19-45-1 (Test)	Rear Area Protection
FM 24-21	Field Radio Relay Techniques
FM 55-4-1 (Test)	Transportation Movements in a Theater of Operations
FM 55-35-1 (Test)	Motor Transport Operations and Motor Transport Units

The following are changed to read:

FM 1-5	Army Aviation Company
FM 1-100	Army Aviation Utilization
FM 7-11	Rifle Company, Infantry, Airborne and Mechanized
FM 19-1	Military Police Support, Army Divisions and Separate Brigades
FM 21-40	Chemical, Biological and Nuclear Defense
FM 31-30	Jungle Training and Operations
AR 190-60	Physical Security for Nuclear Weapons

Page 138, paragraph 1. In line 2, "No. 2" is changed to read "No. 3."

Page 151, figure 101. Add an arrow, like that in figure 102, on the outside of the raised left arm, extending from the closed fist to the elbow.

Page 171, figure 124. Change the bridge symbols to run perpendicular to the water.

Page 130, figure 67. "POW" is changed to read "PW."

Page 133, paragraph 182a. In line 3, "survey equipment" is changed to read "radiological survey or chemical detection equipment."

Page 133, paragraph 182d. In line 2, "right" is changed to read "upwind."

Pages 135-137, appendix I.

The following are deleted:

FM 3-5
FM 11-8
FM 30-7
FM 55-30
FM 55-31
FM 55-54
PMG 35
AR 700-2300-1

Page 173. Figure 125—Continued, is superseded as follows:

Page 174, figure 126. In line 1, under Criteria, "10 ft" is changed to read "100 ft."

Page 174, figure 126. In lines 5 and 6, under Symbol, "a" and "i" are changed to read s and j respectively.

HIGHWAYS

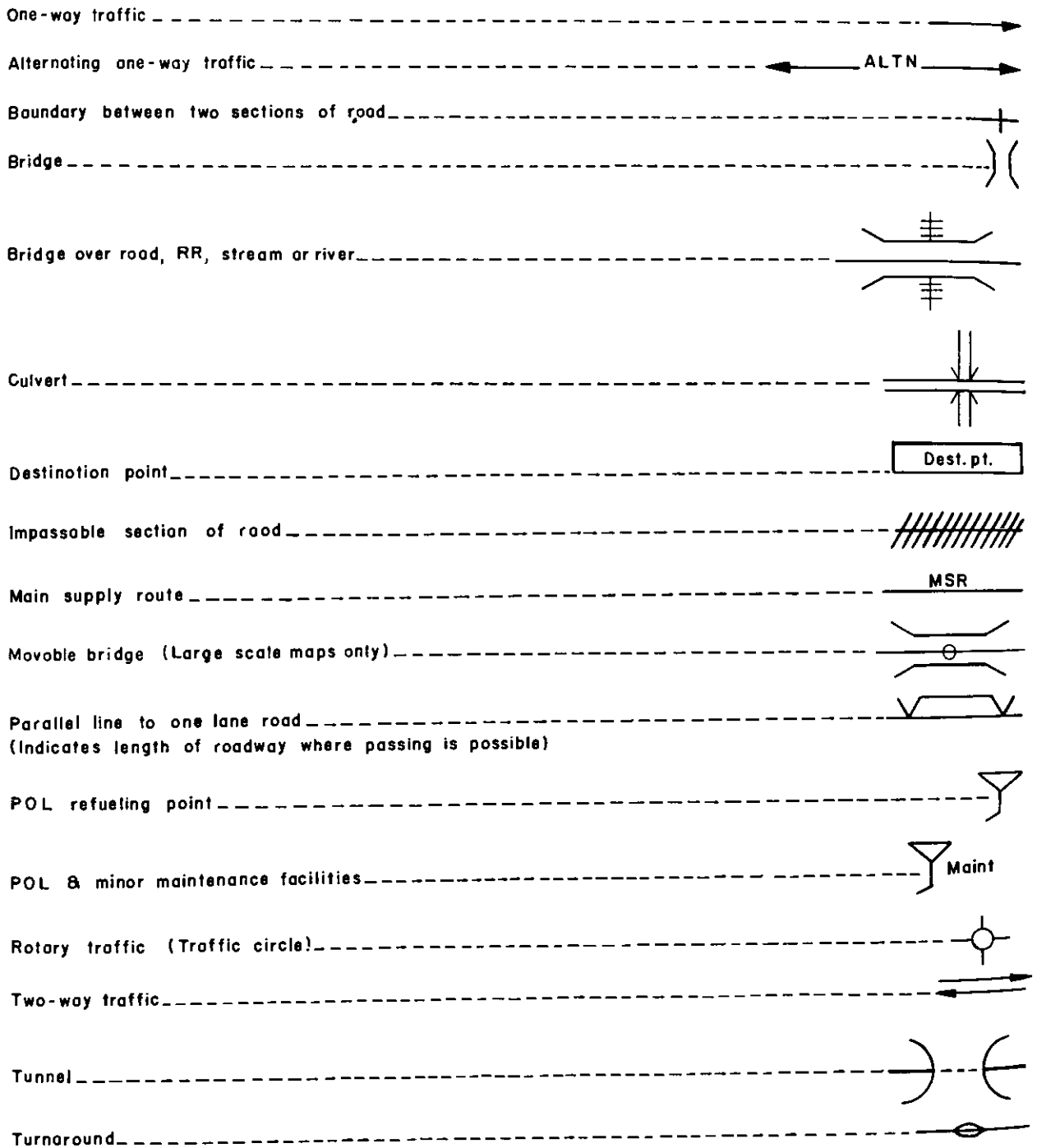


Figure 125. Overlay symbols - Continued

Text Key Page 7
 Manuscript CL, FM 19-25
 Figure No. 125

Figure 125—Continued.

By Order of the Secretary of the Army :

Official

HAROLD K. JOHNSON,
General, United States Army,
Chief of Staff.

KENNETH G. WICKHAM,
Major General, United States Army,
The Adjutant General.

Distribution:

To be distributed in accordance with DA Form 12-11 requirements for MP Traffic Control.

☆ U.S. Government Printing Office: 1968 -- 345-537/5044A

FIELD MANUAL }
 No. 19-25 }

HEADQUARTERS
 DEPARTMENT OF THE ARMY
 WASHINGTON, D.C., 7 October 1964

MILITARY POLICE TRAFFIC CONTROL

	Paragraphs	Page
PART ONE. GENERAL		
CHAPTER 1. INTRODUCTION		
Section I. General.....	1-8	3
II. Role of commanders and staff officers.....	9-11	5
III. The military police.....	12-24	7
CHAPTER 2. SUPERVISING AND PLANNING TRAFFIC CONTROL		
Section I. Supervisory personnel.....	15-21	9
II. Principles of traffic planning.....	22-29	12
III. Traffic studies and data.....	30-35	24
PART TWO. POST CAMP OR STATION		
CHAPTER 3. POINT CONTROL OF TRAFFIC.....		
4. MOTOR PATROLS.....	36-45	32
5. TRAFFIC ENFORCEMENT		
Section I. Introduction.....	46-52	42
II. Traffic violations.....	53-56	45
III. Steps in stopping a violator.....	57-65	50
III. Steps in stopping a violator.....	66-76	55
CHAPTER 6. TRAFFIC ACCIDENTS.....		
GENERAL CONTROL OPERATIONS		
Section I. Parking.....	77-84	59
II. Escorts.....	85, 86	70
III. Traffic signs and signals.....	87-89	73
IV. Traffic controls for construction or detours.....	90-97	76
V. Miscellaneous operations.....	98-100	79
V. Miscellaneous operations.....	101-105	86
PART THREE. THEATER OF OPERATIONS		
CHAPTER 8. INTRODUCTION		
Section I. General.....	106-111	94
II. Role of military police platoon and squad.....	112-116	97
CHAPTER 9. TRAFFIC CONTROL POSTS.....		
10. MOTOR PATROLS IN THEATERS OF OPERATION.....	117-125	98
11. RECONNAISSANCE.....	126-130	103
12. ESCORTS		
Section I. General.....	131-139	106
II. Military police security escort.....	140, 141	110
II. Military police security escort.....	142-146	110
CHAPTER 13. SPECIAL SITUATION CONTROLS		
Section I. Defiles.....	147-150	114
II. Checkpoints.....	151-153	115

*This manual supersedes FM 19-25, 12 December 1958.

	Paragraphs	Page
Section III. Roadblocks.....	154, 155	117
IV. Bridges and other crossing means.....	156-161	118
V. Dismount point.....	162-164	125
CHAPTER 14. SPECIAL OPERATIONS		
Section I. River crossing.....	165-169	127
II. Amphibious operations.....	170-172	129
III. Airborne operations.....	173, 174	131
IV. Desert operations.....	175, 176	131
V. Jungle operations.....	177, 178	131
VI. Northern and mountain operations.....	179, 180	132
VII. Area damage control.....	181-183	133
APPENDIX I. REFERENCES.....		
II. NATO SIGNS.....		136
III. HAND SIGNALS.....		138
IV. EQUIPMENT CHECKLIST.....		143
V. GUIDE FOR PHOTOGRAPHING A TRAFFIC ACCIDENT.....		159
VI. CURVES AND GRADIENTS.....		161
VII. TRAFFIC MAPS.....		165
VIII. RECONNAISSANCE.....		168
IX. NATO ROAD NETWORK.....		170
X. MOTOR VEHICLE EXAMINATION PROCEDURE.....		184
XI. UNITS OF MEASURE AND CONVERSION.....		188
INDEX.....		190

PART ONE GENERAL

CHAPTER 1 INTRODUCTION

Section I. GENERAL

1. Purpose and Scope

a. This manual is a guide to military police and others involved in planning and controlling motor vehicle traffic.

b. This manual presents systems, methods, means, and techniques for controlling traffic on posts, camps, or stations and during field operations.

c. Users are encouraged to submit recommended changes or comments to improve the manual. Comments should be keyed to the specific page, paragraph, and line of the text in which change is recommended. Reasons should be provided for each comment to insure understanding and complete evaluation. Comments should be forwarded directly to the Commandant, United States Army Military Police School, Fort Gordon, Ga. 30905.

d. The material presented herein is applicable without modification to both nuclear and non-nuclear warfare.

2. Definition of Terms

a. In this manual traffic consists of the movements of vehicles, pedestrians, and animals over the roads and highways.

b. Highway traffic regulation is the planning, scheduling, routing, and directing of the use of the roads and highways by traffic so as to meet military requirements. Highway traffic regulating points (FM 55-31) assist traffic headquarters in exercising its responsibility for regulating highway transportation.

c. Military traffic is the movement of military personnel, supplies, and equipment over roads and highways. It is further classified by the degree of control exercised over the movement.

- (1) Organized military movements are movements by internally controlled groups moving on schedule and complying with the highway traffic regulation plan. Convoys, serials, and march units are organized military movements.
- (2) Casual military movements are the movements of individuals or small groups who comply with the highway traffic regulation plan as they perform routine administrative or supply duties.
- (3) Unorganized traffic movements include military traffic moving without internal control or compliance with the highway traffic regulation plan, and nonmilitary traffic which, during its movement, affects military traffic by failing to comply with the highway traffic regulation plan.

d. Military traffic control is the direction of traffic to meet the military requirements.

e. An open route is one over which minimum control is exercised. This control is normally limited to patrols, signs, and traffic control points. A highway clearance (movement credit) is not required for use of this type road.

f. A supervised route is one which requires a highway clearance (movement credit) for the

movement of a unit of 10 or more vehicles. It requires the same military police control as an open route.

g. A dispatch route (a NATO regulated route) is one over which full control is exercised. A highway clearance (movement credit) is required for use of this road. Military police control is oriented toward insuring that the users of this road comply with all schedules, routings, and priorities.

h. A reserved route is one reserved for the exclusive use of a designated unit or specified type of traffic. Military police control is normally limited to insuring that the route is used only by authorized traffic.

i. The traffic circulation plan in highway operations is a plan detailing the use to be made of the transportation network in order to implement the traffic regulation plan.

j. A traffic control plan is a plan for enforcing the provisions of a traffic circulation plan and traffic rules and regulations of a command by military police.

k. The traffic flow system is the traffic control plan and traffic circulation plan being implemented.

3. Military Traffic Control

a. The basic principle of military traffic control is maximum flow with minimum control and direction.

b. Military police, as a part of their function in support of the commander's plan, enforce compliance with highway traffic regulations.

c. Military traffic control is effected through the use of traffic patrols, traffic control posts (TCP), traffic information posts, checkpoints, roadblocks, dismount points, directional signs and control devices, and escorts. It embodies the enforcement of traffic laws and regulations; the prevention of traffic accidents; the investigation of traffic accidents; the conduct of route and area reconnaissance; the conduct of traffic control surveys and studies; and the planning for and rerouting of traffic under emergency conditions to meet the military requirements.

d. Traffic control in the theater of opera-

tions is influenced by and is responsive to the tactical requirement of the combat situation.

(1) The goal of traffic control in the theater of operations is the uninterrupted movement and the certainty of the arrival of vehicles, personnel and cargoes at their intended destinations according to schedule.

(2) The goal of traffic control in the zone of interior (AR 320-5), is the safe, efficient, and economical movement of vehicles, personnel, and equipment.

4. Traffic Engineering

a. Traffic engineering is the planning to insure a smooth flow of traffic. It is accomplished primarily through the proper design of the highway system.

b. Traffic engineering in road design, building, and maintenance provides for an increase in efficient, continuous, and safe flow of traffic by eliminating or minimizing basic traffic frictions. Most terrain may be used as roadway, but failure to select and prepare the terrain for a road impedes the movement of traffic. Normally, traffic engineering allows for a reduction in military police control, and when united with effective education the objective of minimum control may be achieved.

5. Traffic Education

Traffic education provides for informing road users in traffic rules, regulations, and laws that are intended to promote an orderly relationship. The ideal situation is voluntary compliance by each individual with these rules. As individuals adopt voluntary compliance, the need for military police in traffic control should decrease proportionately.

6. Traffic Enforcement

a. Traffic enforcement is any action taken to create a deterrent to the commission of offenses against traffic rules, regulations, and laws. Two major activities in traffic enforcement are the detection of defects in behavior or equipment of the road users and the institution of appropriate action to correct such defects.

b. Effective enforcement encourages voluntary compliance. This enforcement complements traffic engineering and traffic education. The effectiveness of the enforcement can be indicated by the volume of personnel, equipment, and supplies which move safely without interruption or delay. Effectiveness can be further measured by the increase or decrease in the number of traffic accidents. It cannot be measured in terms of the number of violators apprehended or reported.

c. Preventive enforcement is the presence or the suggested presence of military police at points where violations, congestion, and accidents frequently occur. The purpose of preventive enforcement is to deter traffic violations. Preventive enforcement is especially useful where free movement of traffic is essential and detailed control is unnecessary. Military police may be assigned for the specific mission of preventive enforcement. These military police concentrate their efforts on making themselves obvious to users of the roads, supervising traffic and assisting and advising the road users. Properly performed, preventive enforcement tends to create good public relations.

d. Selective enforcement is the planned distribution of military police and traffic control devices so that the enforcement effort is applied where and when it is needed (para. 55).

7. Traffic Planning

Sound and practicable traffic planning is based on the development of balanced programs in traffic engineering, education, and enforcement. Balance between these programs is essential to the effective use of the road net and efficient flow and control of highway traffic.

Section II. ROLE OF COMMANDERS AND STAFF OFFICERS

9. The Commander

The responsibility for all aspects of traffic rests with the commander. The commanders of battalion size and larger units usually delegate their planning and supervisory functions to members of their staff. In the division and larger units, military police are provided as an element of command control to assist in planning and other traffic responsibilities.

8. Traffic Law

Traffic laws vary from state to state as well as between countries; therefore, it is necessary that prior to performing traffic duties the military policeman know the traffic laws, ordinances, and regulations of the particular jurisdiction or jurisdictions in which he is operating. The military policeman performs three general functions in traffic control: first, he directs the maneuver of traffic; second, he encourages voluntary compliance with traffic laws; and third, he enforces traffic regulations, apprehending violators when necessary. To perform these duties the military policeman must know the scope of his authority, the rules of the road, good driving practices, traffic laws, ordinances, and regulations.

a. The rules of the road are outlined in TM 21-305, Manual for the Wheeled Vehicle Driver. The military policeman should be qualified as a driver and be able to apply all the driver material presented in that manual.

b. The Uniform Vehicle Code and the Model Traffic Ordinance published by The National Committee on Uniform Traffic Laws and Ordinances is the common guide used by most communities and states in developing their traffic laws. The Manual on Uniform Traffic Control Devices published by the Bureau of Public Roads establishes the U.S. standard for road signs and control devices. NATO standard signs appear as appendix II. Oversea theaters publish material applicable to host countries.

c. The authority of the military policeman to perform his police functions is received from the commander and the Uniform Code of Military Justice.

10. The Staff

In the interest of simplicity the staff functions presented herein are those of the ROAD Division. They are applicable, with necessary modification, to staffs of other levels and types.

a. The ACofS, G1, has staff responsibility in the area of safety, discipline, law and order. Under field conditions he has an interest in

movements so far as replacements, rotations of individuals, civilian internees, prisoners of war and the headquarters are concerned.

b. The ACofS, G2, has staff responsibility for the collection of information to include road intelligence and counter guerrilla information. Military police personnel may provide valuable information in these areas. In addition, the G2 supervises the issuance of maps and the dissemination of information on terrain, weather, and the enemy. G2 exercises staff supervision over all counterintelligence activities including those involving movements of personnel and supplies.

c. The ACofS, G3, has staff responsibility for all aspects of troop movements under tactical or training conditions. He plans the use of roads when tactical considerations are involved. These activities are coordinated with the G4 at the highway traffic headquarters.

d. The ACofS, G4.

(1) The G4 is the staff officer responsible for transportation and logistical support. Included in his responsibilities are the selection of routes, the scheduling of movements, and the preparation for the commander's approval of the highway regulation plan. Within the G4 section there are specialists in highway movements.

(2) A highway traffic headquarters is established under the supervision and control of the G4. This headquarters has the mission of promoting efficient highway regulation; planning routes, scheduling and directing use of the road net; and serving as a coordinating agency for staff sections and units that also have an interest in the use of the road net. The highway traffic headquarters is composed of representatives of the G4, PM, Engineer and Support Command. It is normal to have on call representatives from the other general and special staff sections as required.

e. The ACofS, G5, is the staff officer responsible for the development and use of civilian resources and personnel. In addition, the G5 is

concerned with the movement of refugees and the local population and coordinates these activities at highway traffic headquarters.

f. Provost Marshal.

(1) The provost marshal is the principal staff officer concerned with traffic control.

(2) His responsibilities include:

(a) Advising the commander and staff on plans, policies and procedures pertaining to traffic control.

(b) Providing a permanent military police traffic control representative at highway traffic headquarters.

(c) Preparing the traffic control plan based on the traffic circulation plan, and coordinating this plan at highway traffic headquarters for incorporation into the highway regulation plan.

(d) Coordinating traffic control activities and policies with other headquarters and appropriate civil authorities.

(e) Providing timely information to commanders of units as to the military police assistance they may expect during a road movement.

(f) Contributing to the formation and assisting in the implementation of a traffic accident prevention program.

(g) Recommending and implementing traffic accident investigation policies (ch. 6).

(h) Coordinating with the safety director concerning traffic enforcement and investigation matters, and providing factual investigative data on accidents.

(i) Exercising operational control over the division military police company and attached or supporting military police units.

(j) Coordinating with G3 concerning the training of military police.

g. The signal officer is responsible for planning signal support beyond the organic capability of the military police.

h. The engineer officer is responsible for road construction and maintenance; bridge construction, repair, and classification; permanent road signs; detailed route reconnaissance; and providing an engineer representative at highway traffic headquarters. The division engineer advises the division commander and staff on matters relating to the condition, capabilities and limitations of the road net.

i. The Staff Judge Advocate is responsible

for furnishing information and guidance concerning the legal aspects of traffic control and traffic enforcement.

11. Support Command

This command furnishes such services as ordnance, motor transportation, maps, general supply, evacuation, and medical support to assist in accomplishing the division traffic control mission.

Section III. THE MILITARY POLICE

12. General

Traffic control requires planning, coordination and team operation to be successful. The organization, equipment, and training of different military police units provide different capabilities for traffic control. Maintaining unit integrity during traffic control operations will enhance the effectiveness of the operation.

13. Military Police Traffic Duties

a. Military police performing traffic duties during peace-time operations will, within the scope of their authority—

- (1) Serve as one of the means available to the commander in his accident prevention and vehicle safety programs.
- (2) Enforce traffic rules, regulations, and orders.
- (3) Operate traffic posts and patrols.
- (4) Conduct traffic control surveys, reconnaissance, and studies.
- (5) Direct traffic at points of conflict or congestion, such as intersections, construction sites, scenes of accidents, and schools.
- (6) Conduct traffic accident investigations and prepare reports.
- (7) Report observations and information on traffic and roads.
- (8) Recommend the types and locations of permanent traffic signs and post temporary traffic signs as required.
- (9) Perform other duties involving the maintenance of security, discipline, law, and order.

b. Military police performing traffic duties during combat operations will—

- (1) Enforce traffic rules, regulations, and the orders of the commander.
- (2) Operate traffic control posts, patrols, information posts, dismount points, roadblocks and checkpoints; provide escorts, and apply other control measures.
- (3) Conduct continuing route and area reconnaissance, assigning specific personnel to this mission as a primary duty, if necessary.
- (4) Report information of area activity, road conditions, bridge conditions, progress of movements, and logistical requirements.
- (5) Actively participate in the counter-guerrilla and rear area security operation.
- (6) Be prepared to implement use of alternate and temporary routes.
- (7) Prepare and post temporary signs.
- (8) Investigate and prepare reports of traffic accidents as directed by the standing operating procedure.

14. Preparation For Traffic Control Duties

a. It is important that the military policeman prepare himself mentally to perform his duties. Mental preparation includes a positive approach that the MP is there to assist in the safe and orderly flow of traffic and to assure compliance by the road users with laws, rules, and regulations. It also includes the elimination of the negative approach or single objective that he is

the "strong arm of the law bent on catching the violator." The latter leads to poor performance of duty which, in turn, adversely affects the attitude of the road user toward the police or traffic enforcement.

b. By his appearance and manner the military policeman encourages respect for the law, thus making his job easier. These qualities are achieved prior to going on duty by thorough preparation and maintenance of his uniform and equipment and thorough knowledge of his orders and duties. Likewise the degree of supervision and inspection performed by his superiors will affect and influence the preparation performed by the individual military policeman.

c. In addition to such common equipment as a pencil, notebook, military police forms (AR 190-45), flashlight and whistle, the military policeman performing traffic control duty may require special equipment. This equipment may include safety equipment, motor vehicle, communications equipment, camera, accident investigation kit, and other like items. To insure that this equipment is ready to serve its function when needed it must be maintained at the highest standard and *inspected* by supervisory personnel at frequent intervals. These high standards of performance, appearance, and maintenance enhance the capability of the military policeman to perform his duties and to achieve the objectives of the traffic control program.

CHAPTER 2

SUPERVISING AND PLANNING TRAFFIC CONTROL

Section I. SUPERVISORY PERSONNEL

15. General

a. Traffic control planning is the staff responsibility of the provost marshal. The provost marshal constantly evaluates the traffic situation, makes recommendations to the commander concerning traffic control, and prepares appropriate regulations and the traffic control plan. In addition, during post, camp, or station operation, the provost marshal prepares the traffic circulation plan, serves as the coordinator for the installation with civilian traffic authorities, and is responsible for the registration of private vehicles on the installation.

b. Most TOE military police units that provide area military police functions have organic operations sections down to company level. These sections are capable, normally, of planning and supervising traffic control operation.

c. The table of distribution for post, camp, or station usually provides appropriate personnel teams (TOE 19-500) to perform necessary functions of traffic control planning and supervision for the provost marshal.

d. The direct supervision of traffic control personnel and operations is accomplished by the military police officers and noncommissioned officers. Every effort is made to maintain unit integrity. Maximum effectiveness and teamwork is achieved when the same officer and noncommissioned officer are responsible for and supervise the performance of duty of military policemen from their own unit.

16. Responsibilities

The responsibilities of the military police

supervisor (officer or noncommissioned officer) in the area of traffic control are to know, understand, and be able to instruct in the principles and techniques of traffic control. The military policeman normally performs his duties individually and only occasionally receives the benefit of direct supervision; therefore, all errors observed or learned during these periods of direct supervision must be immediately corrected. Irregularities that are noted by the supervisor may be an indication of major problems or habits which will adversely affect the proper performance of duty. For example, undistinguishable hand signals may be an indication of inadequate training in point control of traffic. Disregard of minor traffic regulations such as "no parking" signs or "making improper U-turns" may reflect similar attitude toward other violators of these rules. The supervisor must not only be alert to make on-the-spot corrections but also must insure that proper remedial training is taken, if indicated.

17. Report Review Function

A function of the military police supervisor is to assist in the preparation and review of the reports of the military policeman. In the same manner as other reports, traffic reports should be clear, accurate, concise, and complete. The questions who, what, when, where, how, and why should be answered to the best of the military policeman's ability. All sources of information must be identified. Opinions must be separated from facts. All charges must be supported. During the review of reports the supervisor will be constructively critical. Using the

results of his review of accident reports, the supervisor should seek to improve the questioning and recording techniques of the military policeman.

18. The Military Police Supervisor as a Coordinator

a. The supervisor must coordinate the activities of all military policemen to insure team work. Traffic activities of an individual military policeman affect, and are connected with, other military policemen and the traffic plan.

b. When the traffic plan and local SOP do not provide guidance in a given situation, it is the responsibility of the supervisor to provide the necessary instruction and guidance, and to submit appropriate recommendations for changes to the operations section, if required.

c. Coordinating considerations may include:

(1) Fixed traffic post.

- (a) Insure that the main roads are defined, and that a flow pattern is established to meet the needs and is understood by the military policeman.
- (b) Provide guidelines to the military policeman as to when to change the traffic flow. The most common criterion for a flow change is a combination of time and location such as when traffic backs up to a given place, or a certain time elapses.
- (c) Eliminate conflicts with control devices, to include turning off signals or covering signs when necessary.

(2) Realignment of patrols during a disaster. The sudden withdrawal of military police and the requirement to continue the patrol mission should be expected during a disaster. Under these conditions immediate action is required to reassign available military police traffic personnel based on the following general guidelines:

- (a) Adjustment will be accomplished based on the overall police requirement and available number of personnel.

(b) The traffic plan may contain key locations that require military police control at prescribed times. These locations must be manned to insure continuity of the traffic control plan.

(c) Areas of known traffic problems or high accident occurrences are provided military police coverage.

(d) A reduced military police force may result in an overextension of commitments, which will reduce the effectiveness of the police activity. It may be better to leave an area unpatrolled, receiving military police attention only when an incident occurs, than it would be to attempt to patrol all areas.

(3) Supervision at major construction sites or detours. The supervisor should not be restricted in movement and may perform the functions of a mobile patrol through the area. Special emphasis should be placed on patrolling and observing the approaches to a construction or detour area. This will assist in preventing congestion and other traffic problems. During his patrolling the supervisor must constantly check signs and control devices. If there is a shortage of military police and a heavy flow of traffic the supervisor must be prepared to act as a temporary relief for personnel performing point control duty.

(4) Escort duty.

(a) When escorts are used primarily for clearance through traffic, the supervisor must be located where he can best control this movement. Under normal circumstances the supervisor will locate himself immediately in front of the escorted vehicles, thus being able to observe and exercise control over the leading military police vehicle, if used. Escorted vehicles are usually lacking in radio communication, therefore it becomes necessary to rely on signals.

The supervisor should brief the driver of the escorted vehicle on a simple signal system (FM 21-60).

- (b) The escort of a classified movement requires the supervisor to place himself where he can best control the defense of the movement. Under normal conditions he will locate himself immediately behind the escorted vehicle where he can observe the classified movement and direct defense. In developing the escort plan, the supervisor will insure that all-around security is achieved. His plan should prescribe an assigned position and an area of observation for each member of the escort, positions to be assumed when the vehicles stop, and action to take in case of emergency. If possible, a reserve of at least one military policeman should be maintained.

- (5) Actions at accident scene. The senior military policeman present is responsible for coordinating all military police action at the scene of an accident. The completion of the interviews and reports may be accomplished by another military policeman, but the review and authentication of reports is accomplished by the military police supervisor.

19. Patrol Supervisor

a. The patrol supervisor is the senior non-commissioned officer assigned to patrol duty. He operates under the direction of the desk sergeant. The patrol supervisor circulates on an irregular schedule to all patrol areas. To provide the best traffic control, the patrol supervisor should frequently check known areas of traffic congestion. When a new or unexpected traffic problem is reported, the patrol supervisor should visit the scene, evaluate the problem, and report his findings to military police headquarters.

b. The patrol supervisor should be aware of each accident and be prepared to assist and ad-

vice the military policemen who are investigating the accident. Each accident report and traffic report must be critically reviewed by him to insure that it is complete, objective, and accurate.

c. The experience, training, and knowledge of the area of responsibility makes the patrol supervisor one of the chief sources of information concerning the effectiveness of the traffic plan. When on a patrol, and when reviewing military police reports, the patrol supervisor makes a constant evaluation of the traffic plan. He makes recommendations for any necessary or desirable changes.

d. In special situations the duties of the patrol supervisor may be divided between a police patrol supervisor and a traffic patrol supervisor. Under this type of operation the traffic patrol supervisor will exercise primary interest and supervisory control in traffic patrols and point control operations. However, since police patrols also perform functions in the traffic control area, both patrol supervisors have an interest in matters of traffic control.

e. For other duties of the patrol supervisor, see FM 19-5.

20. The Desk Sergeant

a. The desk sergeant is the noncommissioned officer in charge of all military police station and patrol activities. When utilizing the platoon organization the platoon sergeant may fill this position. The desk sergeant is assisted by the desk clerk and radio operator. The fixed location and communications available to the desk sergeant provide the means to control all military police activities. Specific traffic supervisory duties include—

- (1) Assignment of military police to perform specific tasks outlined in the traffic plan.
- (2) Dispatch of military police to traffic accidents and congestion locations.
- (3) Supervision of the preparation, completion, and review of all traffic reports.

- (4) Review of all activities as to their effect on the traffic plan and preparing recommendations to insure that the traffic plan is current and complete.

b. The duties of all personnel assigned to the military police desk are described in FM 19-5.

21. The Military Police Duty Officer

a. The military police duty officer is responsible for all military police activity during his tour of duty. Under the platoon type of operation this position may be filled by the platoon leader (FM 19-5).

b. The duty officer is normally located at the military police station where he is readily avail-

able. Common type traffic incidents that may require immediate personal action by the duty officer are:

- (1) Supervision at serious accident scenes, to include coordination to insure that an investigation has been initiated by the CID when appropriate.
- (2) Determination of the causes of unexpected traffic problems and congestion.
- (3) Determination of action to be taken with major traffic violations and offenders.
- (4) Directing military police activities in incidents involving traffic that are of command interest or that have interest to news media.

Section II. PRINCIPLES OF TRAFFIC PLANNING

22. General

a. A military installation is made up of a number of functional components. Larger installations may contain all of the components listed below:

- (1) Headquarters areas, to include office building complexes.
- (2) Barracks areas.
- (3) Residential areas.
- (4) Service areas to include PX, stores, theaters, service clubs, etc.
- (5) Hospitals and medical facilities areas.
- (6) Industrial areas.
- (7) Warehouse areas.
- (8) Range areas.
- (9) Testing areas.
- (10) Classified and restricted areas.
- (11) Training areas.

b. To insure the integrity of the functional components the following principles should be used as a guide in the establishment of a traffic plan:

- (1) Traffic movement should be concentrated on a minimum number of clearly defined routes. These primary routes should be ample and efficiently controlled so that drivers will be encouraged to use them.
- (2) When establishing the primary circulation system, traffic should be routed

around functional areas rather than through them.

- (3) Traffic movement within an installation should be segregated according to its destination. For example, one route should lead to the service area while another route leads to the headquarters area, in order that the traffic loads for the two areas are not superimposed on one route, resulting in overloading.
- (4) Where there is a major movement from points outside the installation to points within the installation, a direct route is desirable to avoid needless traffic circulation and conflict with internal traffic within the installation.

c. When principles such as these guide the planning of traffic circulation systems within an installation, the traffic and street system can gradually develop to the point where a proper physical plan for an installation can become a reality. All long range changes to the physical features of the installation should meet the requirements of an approved master plan. All new buildings, areas, parking lots, gates, access routes, or modifications of any of these facilities, should be such that they will provide for better grouping of the various functional areas, and will contribute to improvement of the overall physical and circulation plan.

23. Minimizing Traffic Loads

A fundamental step toward minimizing traffic loads on an installation, or between that installation and nearby communities, is to attain the maximum use of available public transportation. As individuals increasingly rely on private automobiles for transportation less efficient use is made of available roadways and parking areas. Techniques to minimize traffic loads include—

- a. Staggering work hours.
- b. Encouraging the use of car pools and ride-sharing.
- c. Improving public transportation to encourage its use instead of the use of private vehicles.
- d. Restricting the number of vehicles authorized to enter the installation.

24. Consideration in Traffic Planning

a. The first step in the development of a new traffic plan, or a review of an existing plan, is to select the routes which could form the primary circulation system. This system, as far as possible, should conform to the physical plan of the installation and have due regard for the integrity of functional components. Routes should be selected which interconnect all these components, and should pass around their borders rather than through them. As a general rule only that number of primary routes necessary to handle the traffic volume and to provide access to the various areas should be selected. All possible steps should be taken to make these routes highly efficient rather than having a greater number of primary arteries of lower efficiency. Through the use of a minimum number of primary routes, problems of route construction and maintenance, traffic control, and police supervision, are reduced.

b. Streets and roads which are not included in the primary routes fall into a secondary category, and can be controlled in accordance with the needs of the area in which they are located. For example, in residential areas streets can be circuitous or contain offsets or dead ends, to discourage through movement; if through movement persists, barriers of some type may be warranted.

25. One-Way Routes

The following principles should serve as a guide for planning one-way routes when used as a part of the circulation system:

a. A narrow roadway may be able to carry a higher volume of traffic with one-way operation than with two-way movement. In a one-way operation left turns become less of a problem, and traffic may move in a greater number of lanes when it all travels in one direction. For example, a 32-foot pavement can carry only two lanes under the two-way pattern; with one-way operation it can accommodate three lanes.

b. When traffic volume causes congestion, action should be taken to eliminate curb parking thus allowing two-way movement to continue, before a one-way system is used to relieve the congestion.

c. Pedestrians and vehicle operators find it easier to cross a one-way route than a two-way route. One-way systems therefore may have application in an area of high traffic volume where the streets follow a regular grid pattern.

d. Special one-way treatments may be used to handle special conditions. For example, at a complex intersection where a number of streets intersect, one or more of the streets of minor importance may be made one-way outbound from the intersection.

e. Caution should be exercised when designating one-way streets. When two one-way streets are substituted for one two-way street, traffic is dispersed over a greater number of streets and may invite through movement in residential or headquarters areas from which it should be excluded. If the creation of one-way streets results in the addition of more mileage to the primary circulation system it increases the task of police supervision and possibly increases the requirement for street maintenance.

f. As a general rule one-way systems have application to installations under three conditions:

- (1) They may be required on certain primary entrance roads to accommodate the inbound rush in the morning and the outbound rush in the evening.

- (2) They may be required in areas that have concentrations of vehicles and pedestrians and narrow streets.
- (3) They may be required in special situations such as at complicated intersections. Such situations may be improved by the use of one or more one-way streets which are not necessarily part of the primary circulation system.

26. Reduction of Accidents at Accident Prone Intersections

If there is an unusual concentration of accidents at any location such as an intersection or a curve, the reason may lie in the physical conditions at that point. Both a collision diagram and a condition diagram (para. 34) should be prepared for this point. Careful examination of these diagrams may reveal the cause of the high-accident rate. Action that may reduce accidents at such location includes—

a. Removal or modification of obstructions, such as shrubbery or signs.

b. Parking prohibitions.

c. Erection of control signs or signals. Conditions under which the erection of signs or signals are warranted are outlined in the Manual on Uniform Traffic Control Devices.

d. Pavement markings.

e. Channelization of traffic.

f. Restrictions on left and/or right turns.

g. Reduction in the posted approach speeds.

h. Addition or improvement of street lights.

27. Parking

a. Ideally no vehicles should park on roadways; roadways are intended for traffic movement and parking should be provided off the street. This principle applies especially to the primary traffic streets and to the streets within the headquarters area. The extent to which curb parking should be permitted is controlled by the traffic circulation plan, the volume of traffic, and the width of the pavement. (Figure 1 shows suggested minimum pavements for parallel parking.)

TWO-WAY TRAFFIC	ONE-WAY TRAFFIC	REGULATION
Less than 27 feet wide.....	Less than 27 feet wide.....	No parking either side
27-37 feet wide.....	23-37 feet wide.....	Parking one side only
38 feet or more	38 feet or more.....	Parking two sides

Figure 1. Minimum pavement widths required for parallel parking on roadways.

TWO-WAY TRAFFIC	ONE-WAY TRAFFIC	REGULATION
Less than 36 feet.....	Less than 32 feet.....	No angle parking
36 to 42 feet.....	32 to 39 feet.....	Angle parking one side
43 to 53 feet.....	40 to 47 feet.....	No parking other side
54 feet or more.....	48 feet or more.....	Angle parking one side
		Parallel parking other side
		Angle parking both sides

Figure 2. Minimum pavement widths for 45° angle parking (secondary streets only).

b. The parking of cars on the street at an angle to the curb should not be permitted except on lightly traveled streets. The accident experience of drivers backing from these angle parking stalls precludes their use on primary streets. Minimum pavement widths on which 45° angle parking is practicable are shown in figure 2.

c. By prohibiting on-street parking near intersections, the accident hazard can be reduced and traffic capacity can be greatly increased.

Parking should be prohibited for a minimum distance of 50 feet each way from a crosswalk. On the approach to a stop sign the prohibition should extend for at least 30 feet from the signs. If 15 percent of the vehicles are turning at a busy intersection, curb parking should not be permitted closer than 150 ft. from the intersection. The extra width of pavement made available by the parking restriction will tend to accommodate the turning movement.

d. In a headquarters area where there may be numerous visitors during the day, or near a PX, bank, or other points of community interest, the use of curb parking space should be regulated. If curb space at such locations is monopolized by employees or personnel on duty in nearby buildings, no parking space will remain for business purposes. To obtain a turnover in the use of such important curb parking space, a limitation should be placed on the length of time that a vehicle is authorized to remain. At points of community interest, a one-hour

limit normally is sufficient. Near headquarters office buildings a limit of one to three hours may be appropriate depending upon the demand for turnover parking and the quantity available.

e. The need for off-street parking facilities at any location is determined by the number of persons employed or on duty in the nearby area. The following formula may be used for a preliminary determination of parking space requirements at a specific location:

$$\text{Number of spaces required} = \frac{\text{Number of personnel} \times \text{Automobile factor}}{\text{Average vehicle occupancy}} \text{ less Existing parking spaces}$$

- (1) The value for "number of personnel" should be the number of personnel concentrated within a radius of 400 feet of the parking area, on the maximum working shift.
- (2) "Automobile factor" refers to the percentage of personnel which normally arrives in this vicinity by private automobile. For example, if 85 percent of the personnel normally arrives by automobile, the automobile factor is .85.
- (3) "Average vehicle occupancy" is based on the number of persons normally arriving in each vehicle at that particular location. This value will normally range from 1.5 to 3.0.
- (4) The value to be used for "existing parking spaces" is the number of stalls now available within the 400-foot radius circle which may be utilized for long-time parking by employees or personnel on duty. If a certain amount of turnover space is required for visitors or other short-time users, this amount of space should not be included in "existing parking spaces."

- (2) Parking facilities entrances and exits should not be located near important intersections. If there is a choice between placing the entrances or exits on a primary route or a secondary route, the entrances and exits should be on the secondary route.
- (3) In planning parking lots, care should be taken to plan to segregate the movement of automobiles from the movement of the pedestrians who are moving to or from their parked cars. For this purpose a desirable parking system is one in which the parking aisles are at right angles to the buildings to which the pedestrians are destined and in which the cars are parked at 90° to the axis of the aisles. With this design the automobiles may enter and leave via the outer entrance to the parking aisles while the pedestrians enter and leave via the end nearest the buildings (fig. 3).

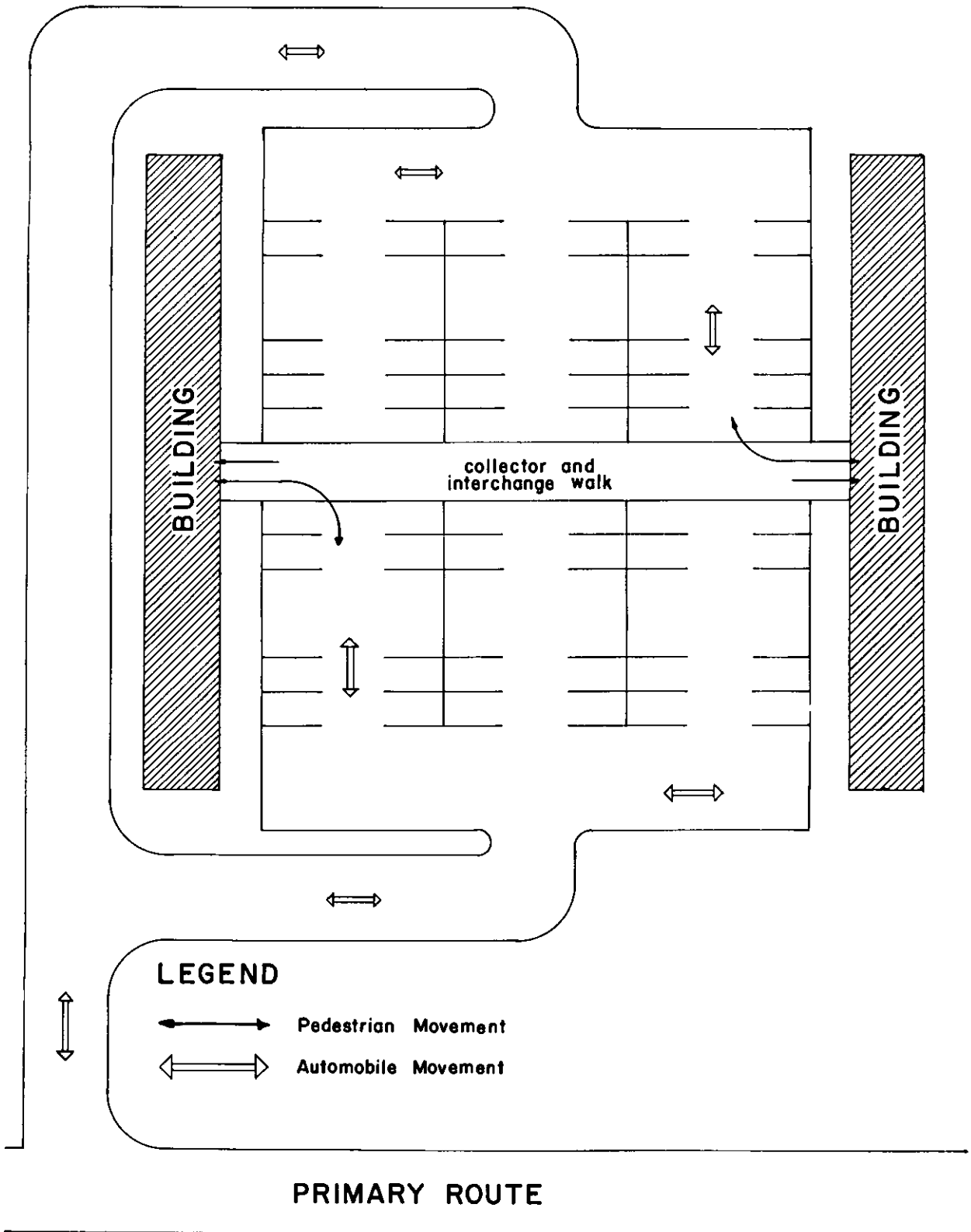
g. Figures 4, 5, and 6 depict typical designs and dimensions for use in planning parking lots.

f. There are several fundamental principles to be followed in locating and planning off-street parking facilities.

- (1) Parking lots should have a minimum number of clearly designed entrances and exits. Inefficient traffic movement on abutting streets will result if each of the parking rows opens onto the street.

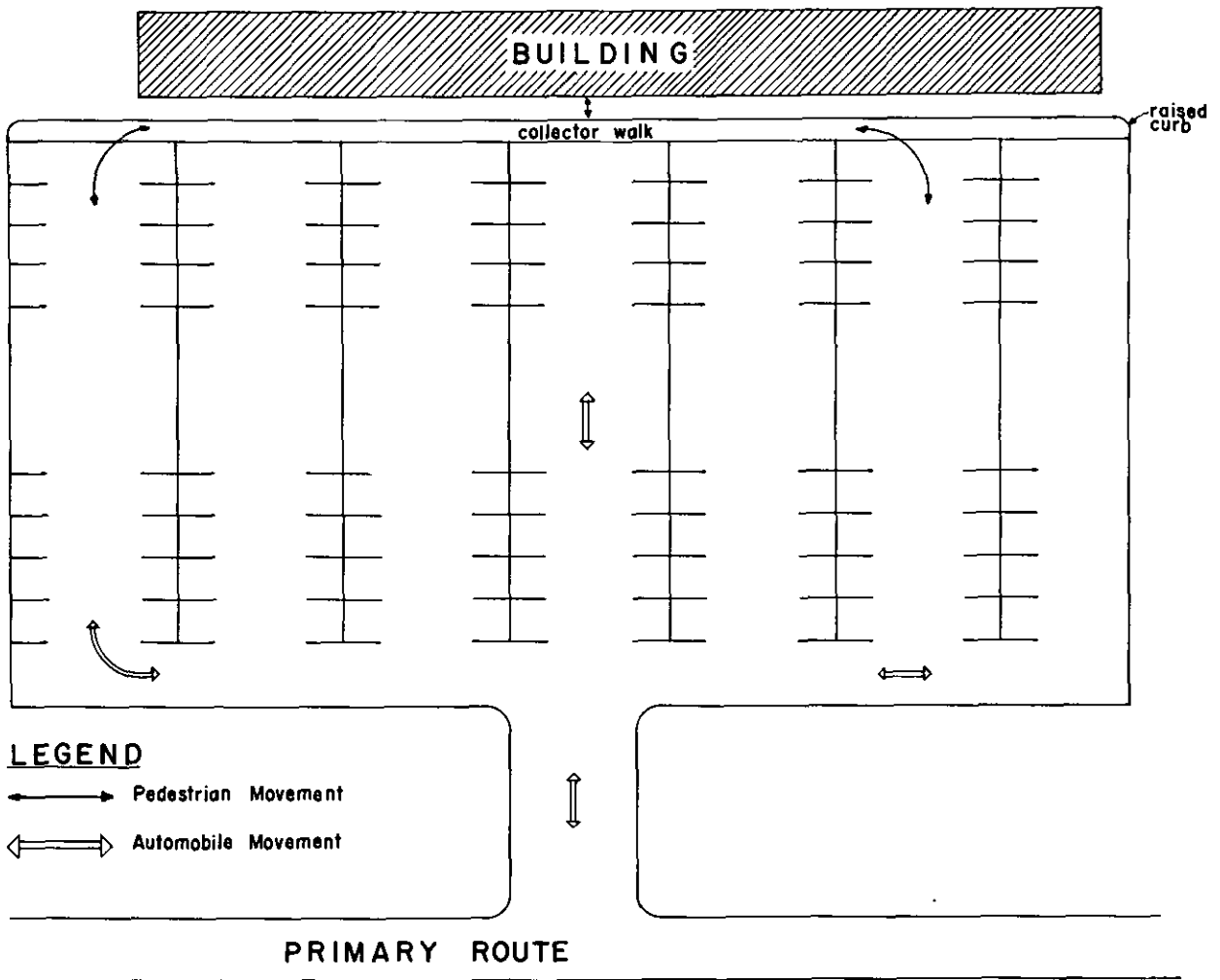
28. Establishing Speed Zones

a. Good practice dictates that speed zones be selected generally in accordance with the type of district through which the road passes. Speed limits which are excessively restrictive may be ignored by drivers, requiring a needless quantity of enforcement effort. More reasonable limits earn a greater degree of driver cooperation,



Serving buildings which require pedestrian interchange.

Figure 3. Parking lot circulation providing minimum conflict between automobiles and pedestrians for a parking area.



Serving one building.

Figure 5—Continued.

allowing police efforts to be directed against the small percentage of drivers traveling at excessive speeds.

b. Prior to the establishment of any speed zone a study of current road speed must be made. Radar or a mirror box may be used to measure the speed vehicles are traveling on the road being studied (para. 58). The following principles should be followed when conducting a speed study:

- (1) The study is made away from intersections or other points of interference which might cause a local reduction in typical speeds.
- (2) To secure results which reflect normal behavior, personnel conducting the

study should be inconspicuously located.

- (3) To assist in achieving valid results, speeds should be recorded on a controlled sampling basis. For example, the speed of every third or every fourth vehicle would be recorded.
- (4) To provide ease in interpreting data, results should be recorded in the field upon a form similar to the one illustrated (fig. 7).

c. When field studies have been completed, a speed accumulation curve may be constructed (fig. 8). This curve shows the total percentage of vehicles which are traveling at or below various consecutive speeds recorded in 2-mile-

RECOMMENDED MINIMUM DIMENSIONS FOR PARKING AREA LAYOUT

90° STALLS

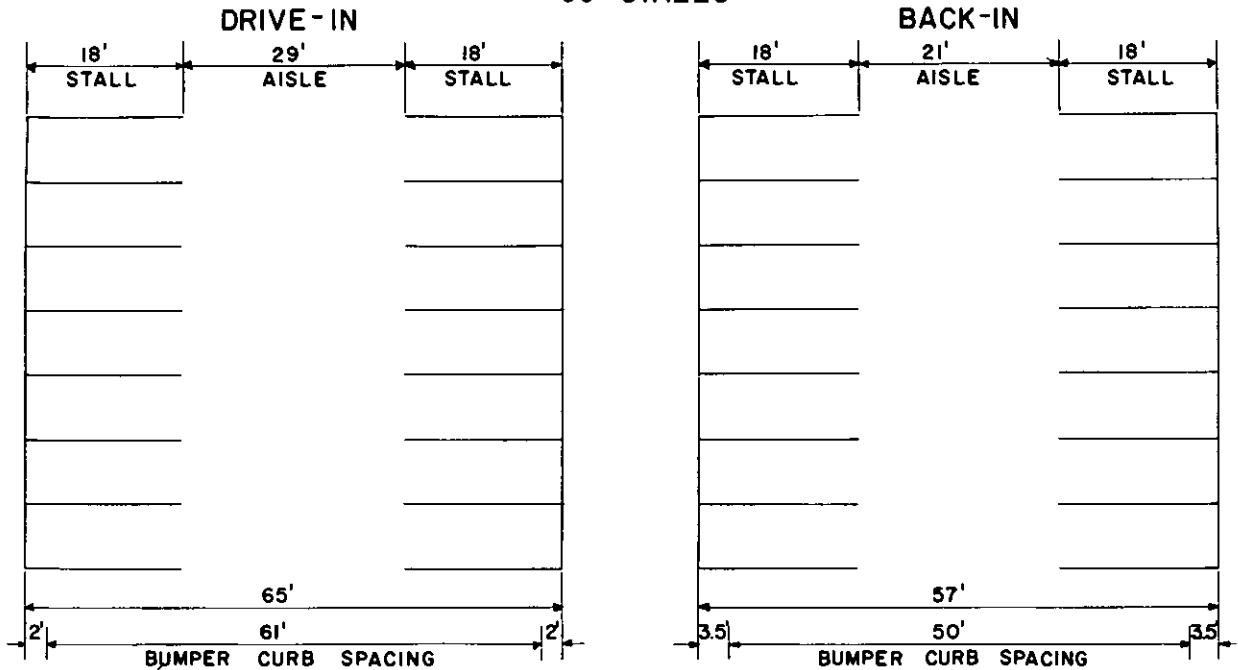


Figure 4. Minimum dimensions for parking area layout 90° stalls. (Minimum stall width for employee is 8.5 feet. Width of 9.0 feet should be used for visitor spaces and 9.5 to 10.0 feet for commissary and PX customers parking.)

per-hour intervals. From this curve it is possible to select the speed range within which the majority of drivers consider it safe to travel. The speed limit on a street where the accident record is not unusually high and no unusually hazardous conditions exist, is fixed at the 5-mile value nearest the 85 percentile. The 85 percentile is the speed which is exceeded by only 15 percent of the drivers observed. Where the accident record is high, or hazardous conditions exist, it may be necessary to select a lower speed value. First, however, enforcement effort should be directed against speeds in excess of the 85 percentile, with the speed limit posted at the 85 percentile.

29. Traffic Control for Special Events

a. Special events such as parades, displays, and sporting events normally generate heavy traffic and require special consideration:

- (1) Direct routes to the area of the special event should be planned. These routes would lead from such places as the residential area of the installa-

tion and from the surrounding communities. These routes should not merge or cross each other.

- (2) Parking areas should terminate the main routes. Ideally, a parking area would be established for each route, thus providing a means of segregating traffic.
- (3) Special parking areas are normally established for official vehicles and special guests. A system of color cards for identifying vehicles of special guests may be used (fig. 9).
- (4) Special routes are planned and used to handle emergency vehicles such as ambulances and fire trucks.
- (5) Detours are planned for the normal area traffic to insure that it does not conflict with the special event traffic.
- (6) The traffic plan, and in particular, instructions for the road user, must be publicized as an aid to traffic control and a means in reducing congestion.

RECOMMENDED MINIMUM DIMENSIONS FOR PARKING AREA LAYOUT

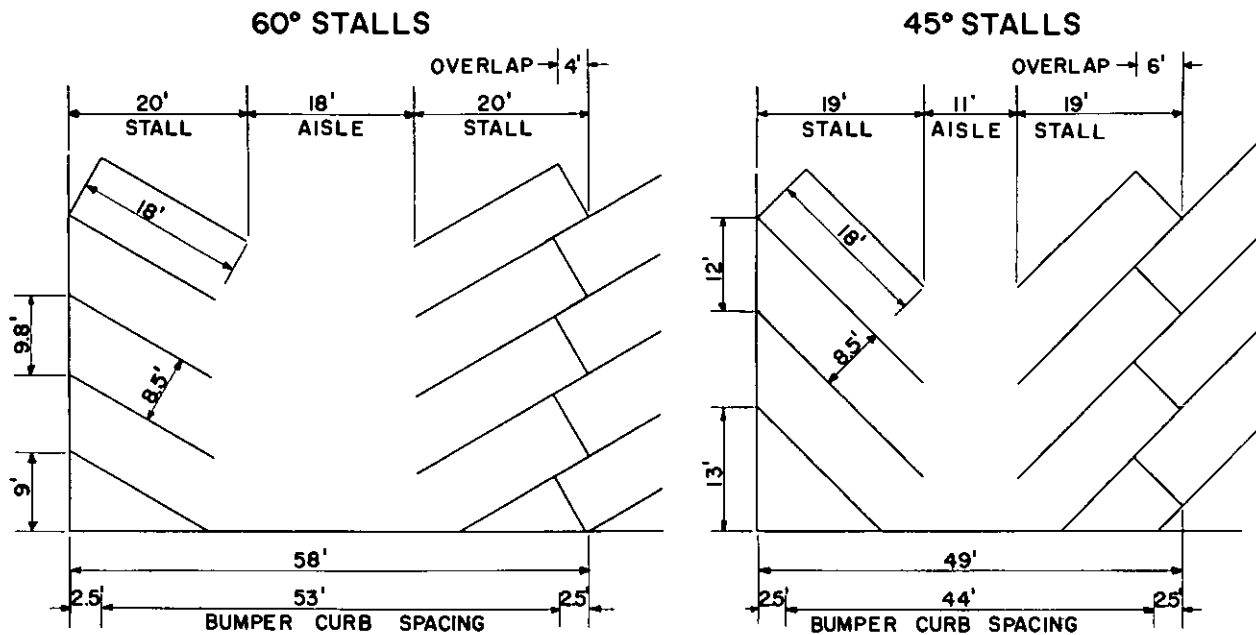


Figure 5. Minimum dimensions for parking area layout 60° stalls and 45° stalls (with stalls width of 8.5 feet.)

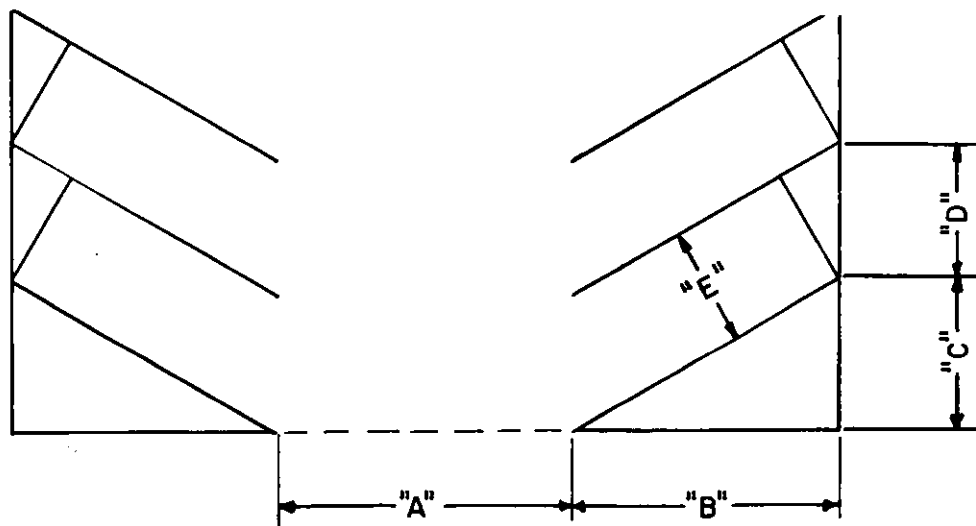


Figure 6. Dimensions for parking stalls.

Figure 6. Dimensions for parking stalls. The measurements listed below provide adequate space for parking and maneuvering. A combination of types may be used on irregular shaped lots if the parking stalls are clearly marked and aisle space "A" is adequate for the parking angle of largest degree.

Type parking	Square feet per car	"A"	"B"	"C"	"D"	"E"
Parallel	297	11'	8'	---	14'	8.5'
35°	335	11.5'	15'	21.4'	14'	8.5'
45°	299	11'	19'	13'	12'	8.5'
60°	276	18'	20'	10'	9.8'	8.5'
90°	228	23'	18'	---	8'	8.5'

SPEED CHECK FIELD DATA

Date _____ Time begun _____ Road _____ Direction _____
 Surface _____ Time ended _____ Location on road _____
 Dist. in ft. _____ Timed _____ Clear width _____ Clear before _____ After _____ Observer _____

Time sec.	M.P.H. for		Passenger		1/4 & 3/4 Ton		Other trucks & buses		Total
	88ft.	176ft.	Tally	No.	Tally	No.	Tally	No.	No.
1.	60.0	120.0							
1.1	54.5	109.0							
1.2	50.0	100.0							
1.3	46.1	92.2							
1.4	42.8	85.7							
1.5	40.0	80.0							
1.6	37.5	75.5							
1.7	35.3	70.6							
1.8	33.3	66.6							
1.9	31.6	63.2							
2.	30.0	60.0							
2.2	27.2	54.5							
2.4	25.0	50.0							
2.6	23.0	46.1							
2.8	21.4	42.8							
3.	20.0	40.0							
3.2	18.7	37.5							
3.4	17.6	35.2							
3.6	16.6	33.3							
3.8	15.7	31.5							
4.	15.0	30.0							
4.2	14.2	28.9							
4.4	13.6	27.2							
4.6	13.0	26.1							
4.8	12.5	25.0							
5.	12.0	24.0							
5.5	11.5	21.8							
6.	10.0	20.0							
6.5	9.2	18.5							
7.	8.5	17.1							
7.5	8.0	16.0							
8.	7.5	15.0							
8.5	7.0	14.1							
9.	6.6	13.3							
10.	6.0	12.0							
11.	5.4	10.9							
12.	5.0	10.0							
14.	4.2	8.5							
16.	3.7	7.5							
18.	3.3	6.5							
20.	3.0	6.0							
Total Timed									
Not Timed									
Grand Total									

Figure 7. Sample speed study field sheet.

SPEED ACCUMULATION CHART

SUMMARIZED SPEED CHECK DATA

SPEED INTERVALS	NUMBER OF VEHICLES	PER CENT	CUMULATIVE PER CENT
TOTALS	200	100.0	
15 -- 16	1	0.5	0.5
17 -- 18	1	0.5	1.0
19 -- 20	3	1.5	2.5
21 -- 22	2	1.0	3.5
23 -- 24	3	1.5	5.0
25 -- 26	3	1.5	6.5
27 -- 28	6	3.0	9.5
29 -- 30	6	3.0	12.5
31 -- 32	9	4.5	17.0
33 -- 34	10	5.0	22.0
35 -- 36	22	11.0	33.0
37 -- 38	33	16.5	49.5
39 -- 40	26	13.0	62.5
41 -- 42	22	11.0	73.5
43 -- 44	13	6.5	80.0
45 -- 46	8	4.0	84.0
47 -- 48	8	4.0	88.0
49 -- 50	6	3.0	91.0
51 -- 52	5	2.5	93.5
53 -- 54	4	2.0	95.5
55 -- 56	3	1.5	97.0
57 -- 58	2	1.0	98.0
59 -- 60	2	1.0	99.0
61 -- 62	2	1.0	100.0
63 -- 64	0	0	100.0

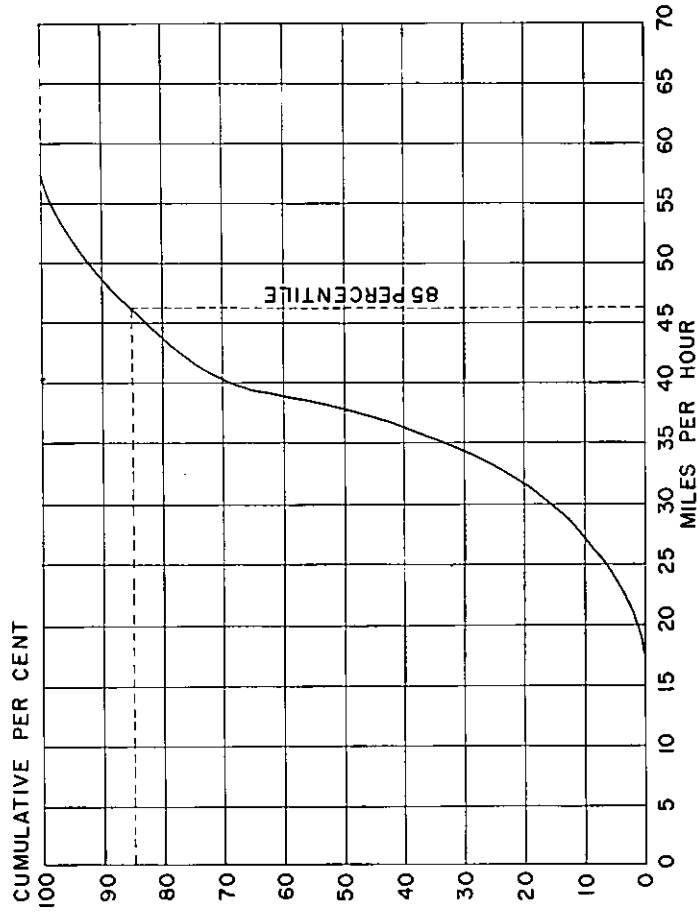


Figure 8. Sample speed accumulation curve with a summarized speed check.

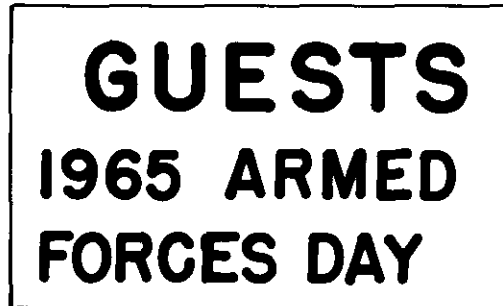


Figure 9. Sample special parking card. These cards are locally fabricated and should be different for each event.

The appropriate information officer should be contacted for necessary publicity.

- (7) Maximum use is made of guide and direction signs.
- (8) Helicopters may be used by super-

visory personnel to provide maximum observation of traffic thus allowing the placement of control personnel or devices where and when needed.

- b. The traffic plan is normally announced in the form of map, sketch or strip map (fig. 10).

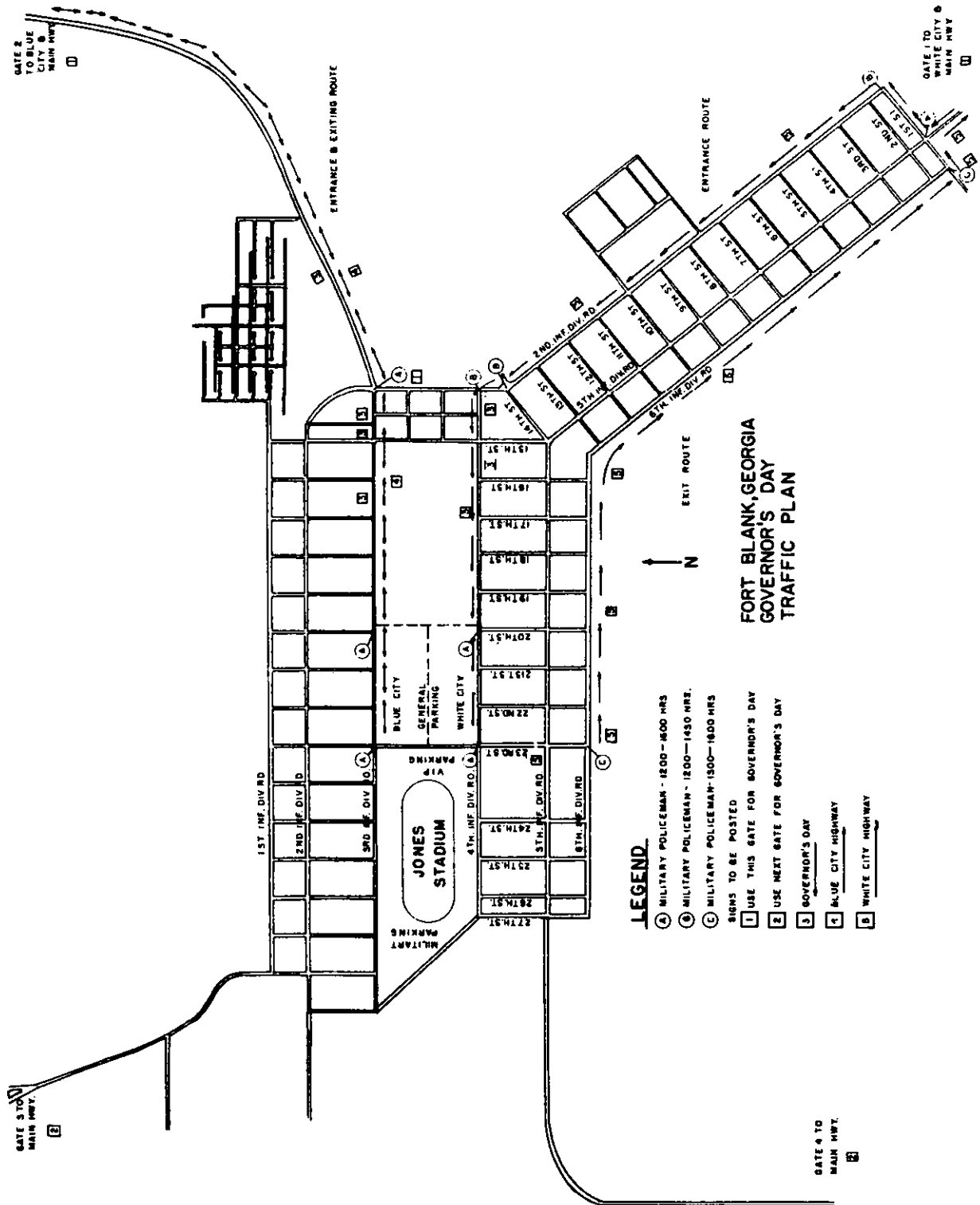


Figure 10. Sample traffic plan map for a special event.

Section III. TRAFFIC STUDIES AND DATA

30. General

For traffic control and regulation to be successful, they must be predicated on facts rather than on opinions. Whenever a question arises as to the need for a certain regulation or a new form of control, the question should be examined to decide whether traffic facts can be gathered as a basis for judgment.

31. Volume Studies

a. Data on the volume, to include direction, of traffic movement is a basic tool in traffic operations. When volume data are to be obtained for the study of a particular problem, counts are taken at the time of day when that problem is experienced. Generally, this means during peak traffic hours.

b. The field sheet shown in figure 11 is used to record movements through an intersection. Spaces are provided on the sheet for recording each type of movement separately. In order to identify clearly maximum conditions, data is recorded by 10, 15, or 30 minute periods; a separate sheet is used for each period. Two experienced men can record all movements at intersections having volumes as high as 1500 vehicles per hour.

c. When traffic volume counts are taken for the purpose of studying a problem of congestion, it is sufficient to count movements only during the peak period. To guard against basing decisions on abnormal conditions, it is advisable to take counts on 2 days. After the field work has been completed, information can be summarized on a graphic sheet, as shown in figure 12. One sheet is prepared for the morning rush period and a second sheet for a similar period during the evening peak.

d. Volume data are useful in determining the need for stop signs or signals, the need for curb parking restrictions, to guide roadway design, and for a number of similar purposes. Experience in the field of traffic engineering is required for many of the interpretations which may be drawn. As a general guide to the significance of traffic counts, the following yardsticks may be used:

- (1) If the maximum volume of traffic traveling in both directions on a street is found to be less than 200 vehicles per

hour, with little or no cross traffic and the area has not experienced an accident problem, it is unlikely that any form of traffic control is necessary.

- (2) In an area where there are intersections every few hundred feet on which vehicles or pedestrians may cross the primary road, 300 to 400 vehicles per hour is a reasonable maximum limit for the volume of traffic that can be carried by a primary street having one lane in each direction.
- (3) On a multiple lane street with light cross traffic, 500 to 700 cars per lane per hour is considered a heavy traffic load.
- (4) A multiple lane expressway where all cross traffic is prohibited has a capacity of 1500 vehicles per lane per hour.

32. Driver Obedience Studies

a. Facts on driver obedience to traffic control devices are useful in appraising the level of obedience both at specific locations and on an area-wide basis. Obedience studies are commonly made at intersections controlled by stop signs or signals, for either of two reasons: as part of a high accident frequency intersection study; or to determine the area-wide average, at 20 or 25 similarly controlled intersections within an area. When an obedience study is made to obtain data on an individual location, the time selected should agree with the purpose. The period should cover at least one hour and at least 50 vehicles for either study. If volumes are too high for the available personnel to check every vehicle passing stop signs at an intersection, then every third, fourth, or fifth vehicle should be checked. At signalized intersections, every vehicle should be checked. Samples of the field sheets used during obedience studies are shown in figures 13 and 14.

b. After these studies are summarized, the level of obedience may be judged on the following basis:

- (1) At signalized intersections: If 99 percent of all motorists enter on green, obedience is excellent. If fewer than 97 percent enter on green, obedience is poor; reason for the poor obedience

should be determined and appropriate action taken through engineering, education, and enforcement as necessary to effect improvement.

(2) For stop sign observance: If 75 percent of all motorists make a full stop before entering the intersection, obedience is excellent. Fifty to 75 percent

VEHICLE VOLUME

FIELD SHEET

DATE _____ LOCATION _____

WEATHER _____ ROAD SURFACE CONDITIONS _____ TIME TO _____ FROM _____

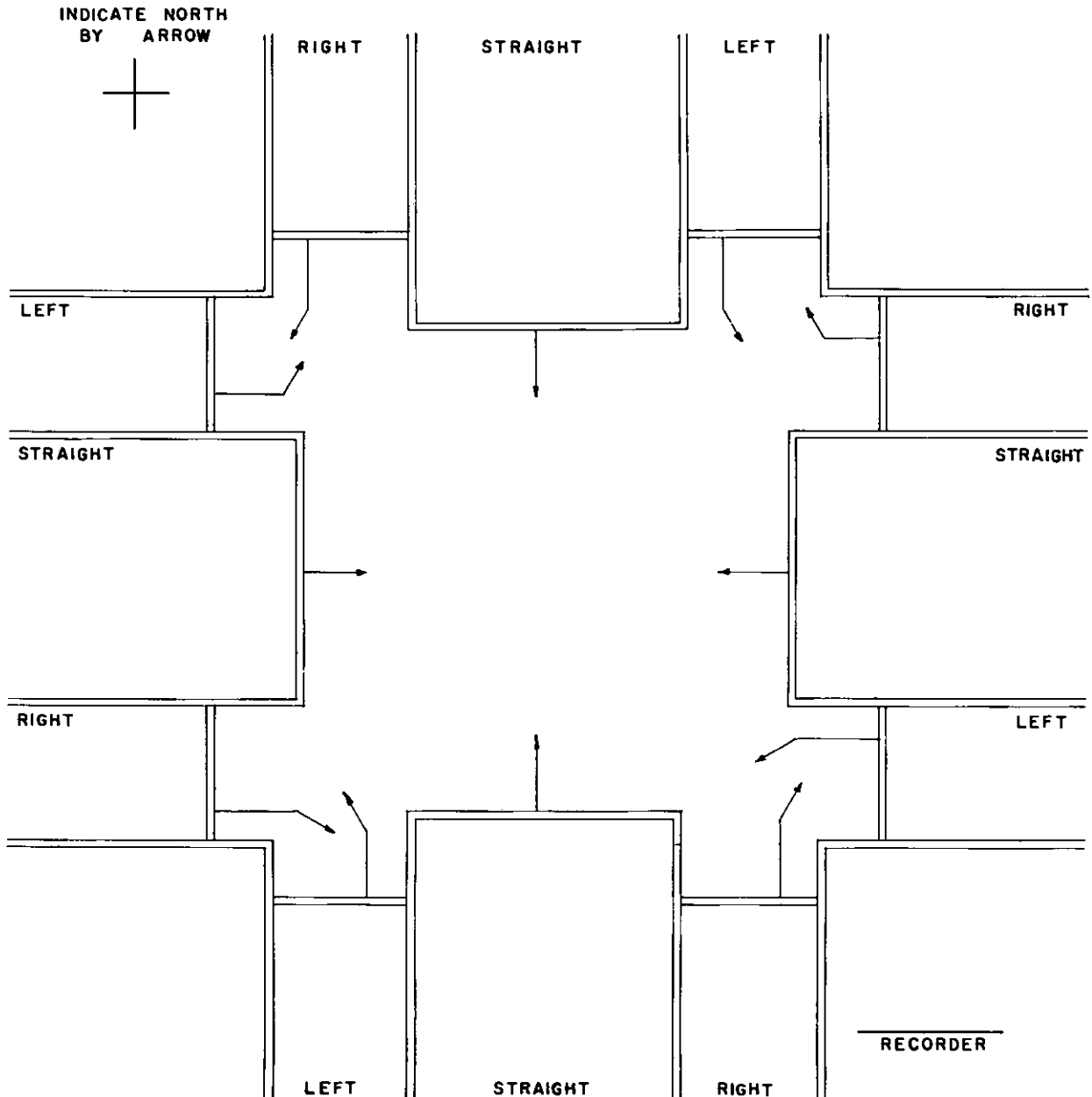


Figure 11. Field sheet for study of traffic volume and movements.

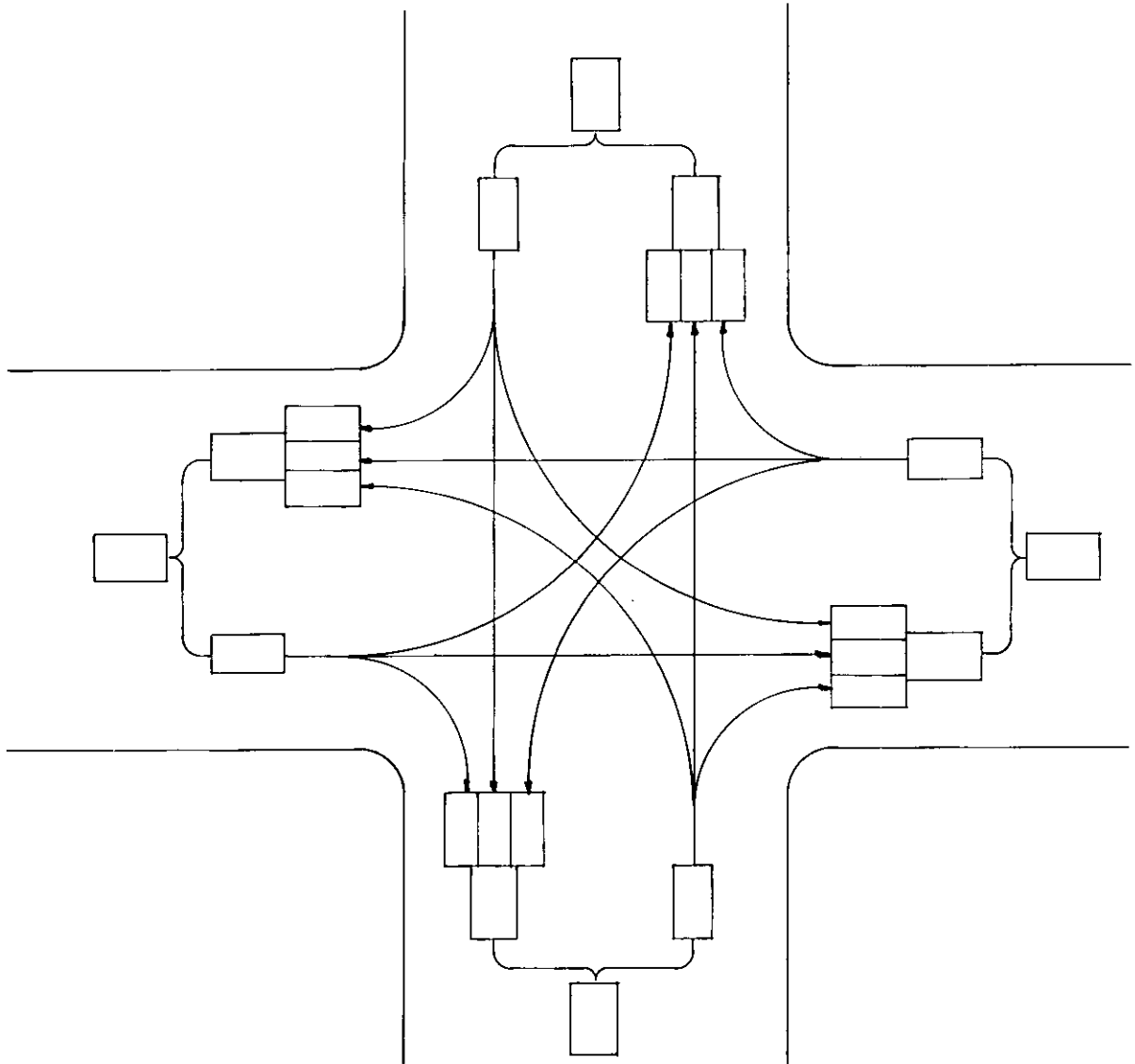
VEHICLE VOLUME

GRAPHIC SUMMARY SHEET

LOCATION _____ DATE _____
 TIME _____ HOURS FROM _____
 _____ TO _____
 _____ TO _____
 WEATHER _____
 ROAD SURFACE CONDITION _____

 COMPILED BY _____

INDICATE NORTH BY ARROW



REMARKS & RECOMMENDATIONS _____

Figure 12. Sample graphic summary sheet for traffic volume summary.

DRIVER OBSERVANCE OF STOP SIGNS

FIELD SHEET

LOCATION _____

TIME _____ TO _____ WEATHER _____

	ENTERED FAST OVER 15 M.P.H.	
	ENTERED SLOW - 4-15 M.P.H.	
	PRACTICALLY STOPPED - 0-3 M.P.H.	
	STOPPED BY TRAFFIC	
	VOLUNTARY FULL STOP	
RIGHT	STRAIGHT	LEFT
←	↓	↘
←	↑	↗
LEFT	STRAIGHT VOLUNTARY FULL STOP	RIGHT
	STOPPED BY TRAFFIC	
	PRACTICALLY STOPPED - 0-3 M.P.H.	
	ENTERED SLOW - 4-15 M.P.H.	
	ENTERED FAST OVER 15 M.P.H.	

DATE _____


RECORDER _____

Figure 13. Sample field sheet for stop sign observance study.

TRAFFIC SIGNAL OBSERVANCE

FIELD SHEET

DATE _____ LOCATION _____
 WEATHER _____ ROAD SURFACE CONDITIONS _____
 TIME FROM _____ TO _____

INDICATE NORTH BY ARROW


ENTERED ON RED			ENTERED ON RED			ENTERED ON RED		
ENTERED ON AMBER			ENTERED ON AMBER			ENTERED ON AMBER		
ENTERED ON GREEN			ENTERED ON GREEN			ENTERED ON GREEN		
ENTERED ON RED	ENTERED ON AMBER	ENTERED ON GREEN	L	S	R	L	S	R
ENTERED ON RED	ENTERED ON AMBER	ENTERED ON GREEN	L	S	R	L	S	R
ENTERED ON RED	ENTERED ON AMBER	ENTERED ON GREEN	L	S	R	L	S	R
ENTERED ON GREEN			ENTERED ON GREEN			ENTERED ON GREEN		
ENTERED ON AMBER			ENTERED ON AMBER			ENTERED ON AMBER		
ENTERED ON RED			ENTERED ON RED			ENTERED ON RED		

LEGEND
 R- RIGHT TURN
 L- LEFT TURN
 S- STRAIGHT AHEAD

RECORDER _____

Figure 14. Sample field sheet for traffic signal observance study.

is good obedience. Below 50 percent indicates need for improvement by the same procedures outlined in (1) above.

33. Speed and Delay Studies

a. Speed and delay studies can produce valuable data for evaluation of the following factors: average speed of traffic; causes of delays; amount of time lost by delays; location of delays. A speed and delay study made before a route is improved may indicate that other studies are needed, and pinpoint specific problems. A similar study after improvements have been made will indicate their effectiveness.

b. Usually speed and delay studies are made during peak periods but may also be useful at other times when congestion occurs. Data are collected by two-man teams—a driver and an observer. The observer's equipment consists

of a stopwatch, clipboard and field forms. Forms provide space to record location, time, cause of delay and length of delay. In order to get average speed data, the driver must "float" with traffic—or try to maintain its average speed. The usual rule of thumb is to pass a vehicle every time the "float" car is passed.

c. The summary sheet should provide information on distances and times so that average speeds may be calculated; in addition, it usually totals the number of delays and total time lost from each cause. In order to get reliable data, several runs should be made for each time and set of conditions. It is also useful to know how much maximum and minimum speeds differ from the average. Following is a brief listing of some of the deficiencies along a route which a study of summary sheets may reveal:

- (1) Ineffective signal control (poor coordination, spacing, or lack of signals).
- (2) Ineffective use of stop signs.
- (3) Lack of proper parking regulations.
- (4) Lack of effective provision for turning movements.
- (5) Conflicts between pedestrians and vehicles.

34. Common Traffic Data

a. *Traffic Spot Maps.*

- (1) A traffic spot map is designed primarily to show those locations which have high accident and traffic violation occurrence. The map should be large enough to include the complete road net of a post, camp, station, or city. The spot map is an important source of information for the traffic accident prevention program. It will be located so that the military policeman can use it when preparing himself for duty. At the end of each year, the map should be photographed and the picture filed for future reference and for comparison with the current spot map.
- (2) After an accident report or a report of traffic violation has been processed the personnel assigned to the military police station will post the location of the incident on the map by use of a pin. The pin will be marked on its head with a symbol, or pins with heads of different colors may be used. The legend of the map will usually contain no more than five or six such symbols or colors.

b. Traffic Time Charts. Traffic accidents and incidents are graphically summarized by the hour and by the day. This information is also obtained from the reports prepared by military policemen and the charts are used in the traffic accident prevention program.

c. Traffic Violation Charts. Violation charts are summaries of reported traffic violations arranged in such a way as to portray graphically the most common reported violation. These charts are useful in selective enforcement activities.

d. *Traffic Accident Data.*

- (1) Common methods used to present accident data are—
 - (a) Summaries. These are written collections of extracts from reports of accidents. While prepared as tools for use in traffic planning and operation, they can also be used as aids in preparing the military policeman for accident investigation duties.
 - (b) Collision diagrams and condition diagrams. These are prepared on accident prone locations.
 1. The collision diagram (fig. 15) usually reveals any pattern of traffic accidents that develop at the point being studied. Traffic accidents can be grouped into a number of patterns which include—
 - (a) Right angle collisions.
 - (b) Left turn collisions.
 - (c) Rear end collisions.
 - (d) Pedestrian and vehicle collisions.
 - (e) Time of day pattern.
 - (f) Seasonal pattern.
 - (g) Road and weather condition pattern.
 2. The condition diagram (fig. 16) is a scale drawing which provides an accurate picture of the physical conditions at the location under study. Of particular interest in the condition diagram is the "visibility triangle" which depicts the area clearly visible to a driver at a given intersection. This diagram is used to evaluate the effect of obstructions to the driver's view and shows conditions for which the military policeman must be watchful.
- (2) Both the collision diagram and the condition diagram provide guidance to the military police in preparing programs to reduce accidents and traffic congestion. They also serve as measurements of the validity of information that is reported by witnesses of an accident. Copies of completed collision and condition diagrams may be included in the patrol packet

COLLISION DIAGRAM DATE 10-30-56
 LOCATION MAPLE AVE. & TENTH STREET

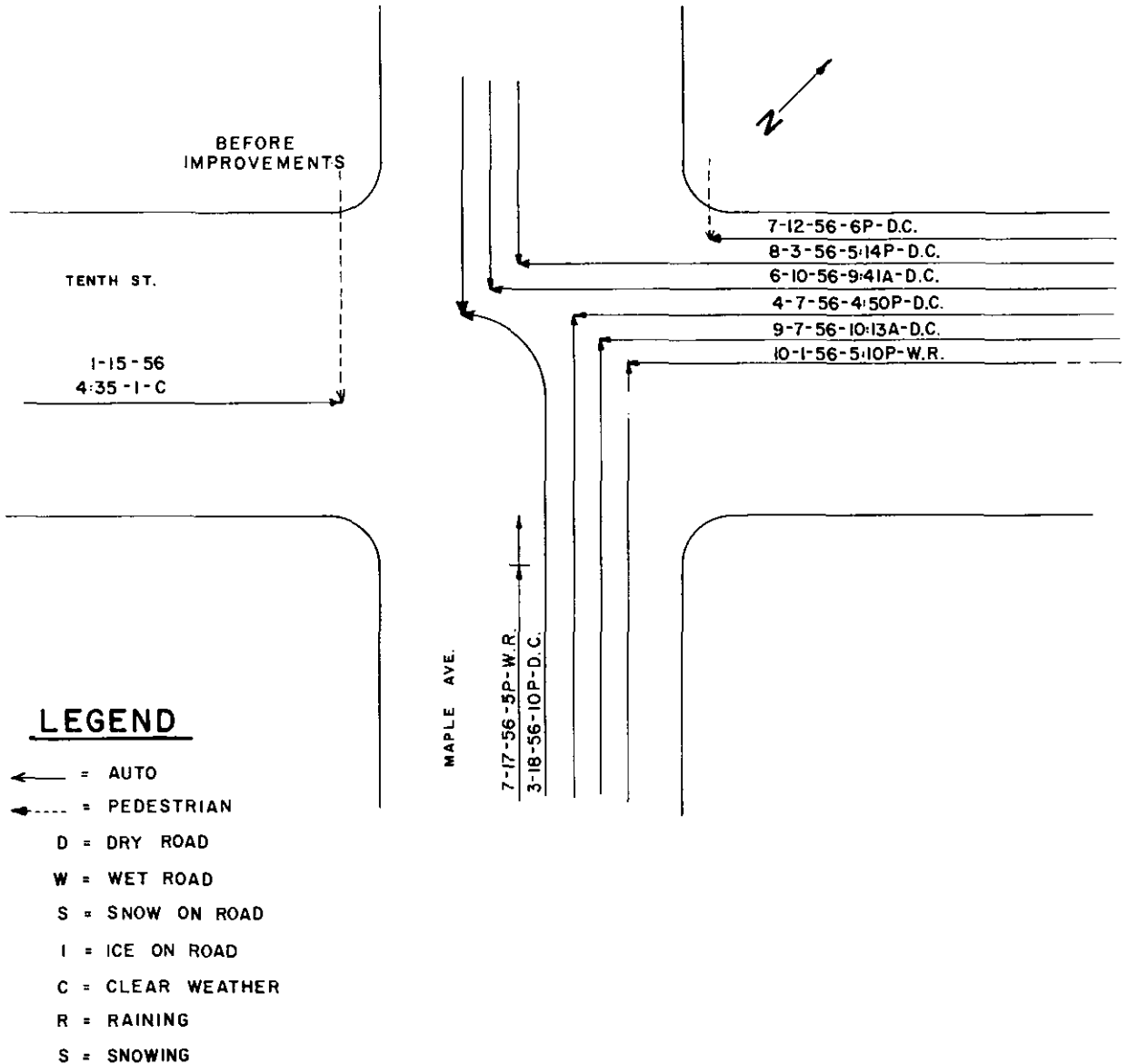


Figure 15. Sample collision diagram.

for the area and in the briefing file used by the military police supervisor in preparing personnel for duty.

35. Condition Map

a. Street and road condition maps are prepared to reflect current factors affecting the street and road net. Patrols supply the needed information. Required information is programmed by the military police headquarters for a given street or road. The requirement

may take the form of a patrol reconnaissance to confirm the condition as portrayed on the current "Street and Road Condition Map."

b. Conditions that may be portrayed on street and road condition maps are:

- (1) Physical conditions, to include: road surface, weight-carrying capacity, and width.
- (2) Speed zones.
- (3) Parking restrictions.

- (4) Locations of signs and control devices.
- (5) Rerouting plans for major roads in case of a disaster or construction.
- (6) Limits of vehicles that may use a road, categorized by vehicle weight, vehicle

- size, and the total number that may use a road in a one-hour period.
- (7) Construction and road maintenance projects.
- (8) Other traffic regulations.

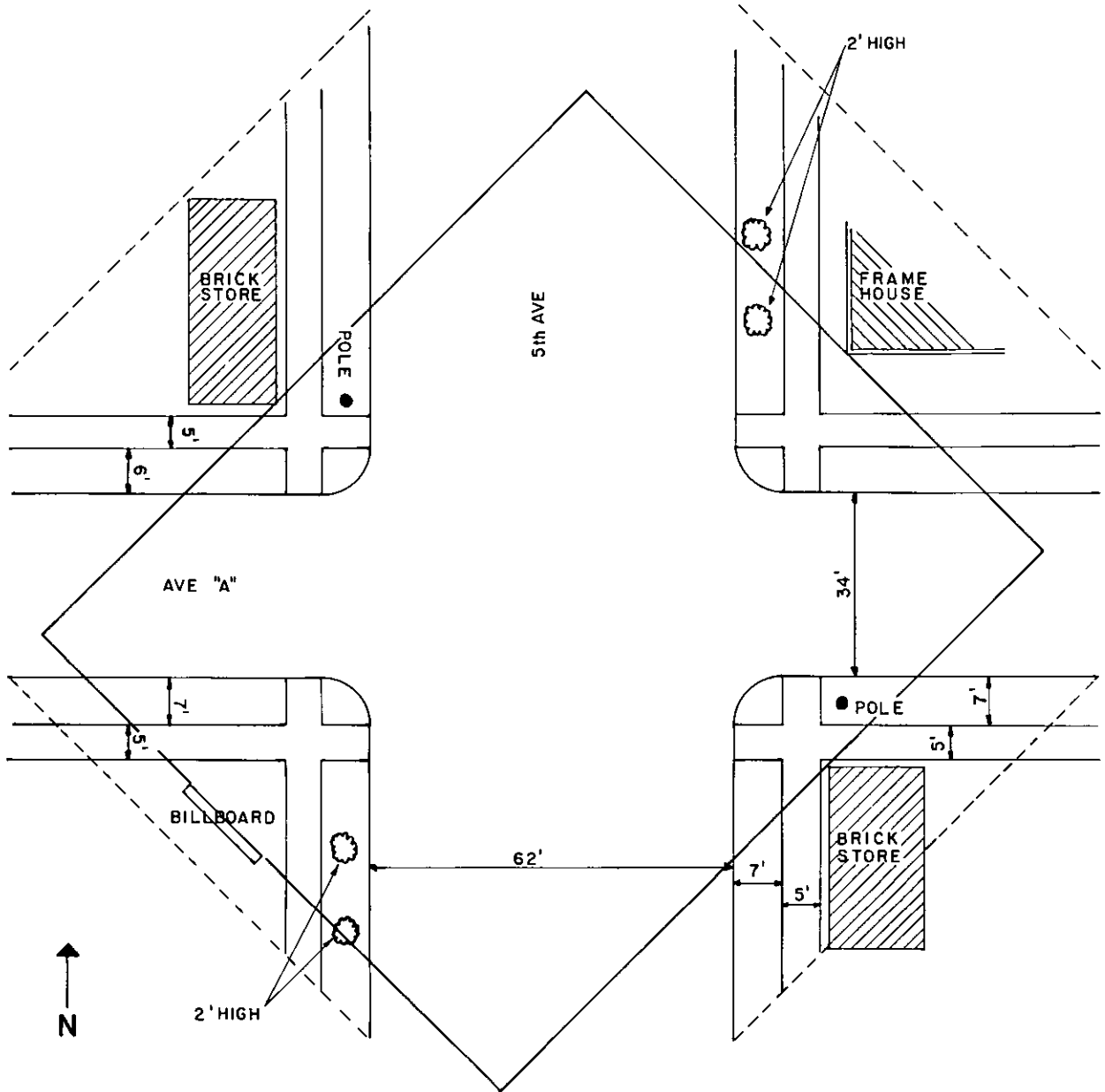


Figure 16. Sample condition diagram. Dotted lines show the required visibility for the 85 percentile speed of this road. The solid lines are the actual visibility triangles. The following are certain predetermined speeds and measurements to determine visibility distance from intersecting curblines:

Speed expressed in miles per hour	Distance from intersection of curblines
25 MPH and less	75 feet
26 MPH-35 MPH	150 feet

Speed expressed in miles per hour	Distance from intersection of curblines
36 MPH-50 MPH	275 feet
51 MPH and over	425 feet

PART TWO POST CAMP OR STATION

CHAPTER 3 POINT CONTROL OF TRAFFIC

36. General

Point control of traffic is simply defined as the control used at an intersection or other point of possible traffic conflict and congestion. Military police on patrol control duty supervise and control vehicular and pedestrian traffic to insure safe, rapid, and efficient movement of traffic. Point control of traffic is established only when necessary since one of the guiding rules is, "maximum flow with minimum control and direction." Point control is integrated with the traffic control plan prepared by the command to insure continuous flow of traffic.

37. Rules for Point Control

a. Point control will normally be established when the road net is inadequate to handle the traffic, or when serious congestion or conflict occurs, or can be anticipated.

b. While performing duty at a traffic control point the military policeman will insure that traffic flows according to the traffic flow system, and that road users are deterred from doing things that disrupt the traffic flow system. Emergencies will be handled immediately and every effort will be made to restore the normal flow of traffic if it is interrupted (para. 43 and 44).

c. Traffic will be expedited within the traffic flow system, since every delay, no matter how trivial, affects the entire system. Delays at one location may cause delays at other locations in the traffic flow system for times far in excess of the initial delays. These delays may serve as contributing causes of accidents and a source of irritation to the road user, thus

adversely affecting his attitude towards voluntary compliance.

d. Military police on point control of traffic assist in reducing accidents by reducing congestion and encouraging drivers to comply voluntarily with the traffic flow system. When congestion occurs drivers have a tendency to disregard both the rights of others and their own safety.

e. The goal of all military police on traffic duty is to keep traffic moving safely and to improve services to the command and the road users.

38. Preparation for Point Control of Traffic

a. Upon being assigned to a traffic control point the military policeman should gather all possible information on the location. Included in this information are briefings from his supervisors, special problems at that location, and its relationship to the traffic flow system. Ideally, the military policeman should have an opportunity to observe the control point in operation and to have a break-in period.

b. Available and necessary safety equipment should be issued for use by the military policeman in this type of duty. The imagination and initiative of the individual military policeman and his supervisor may indicate a requirement for additional safety equipment to make the job of point control of traffic safer and more efficient. Some of the most common normally available safety type equipment used by military police on point control duty include—

- (1) Reflectorized crossbelts and sleeves which make the military policeman easily distinguishable.

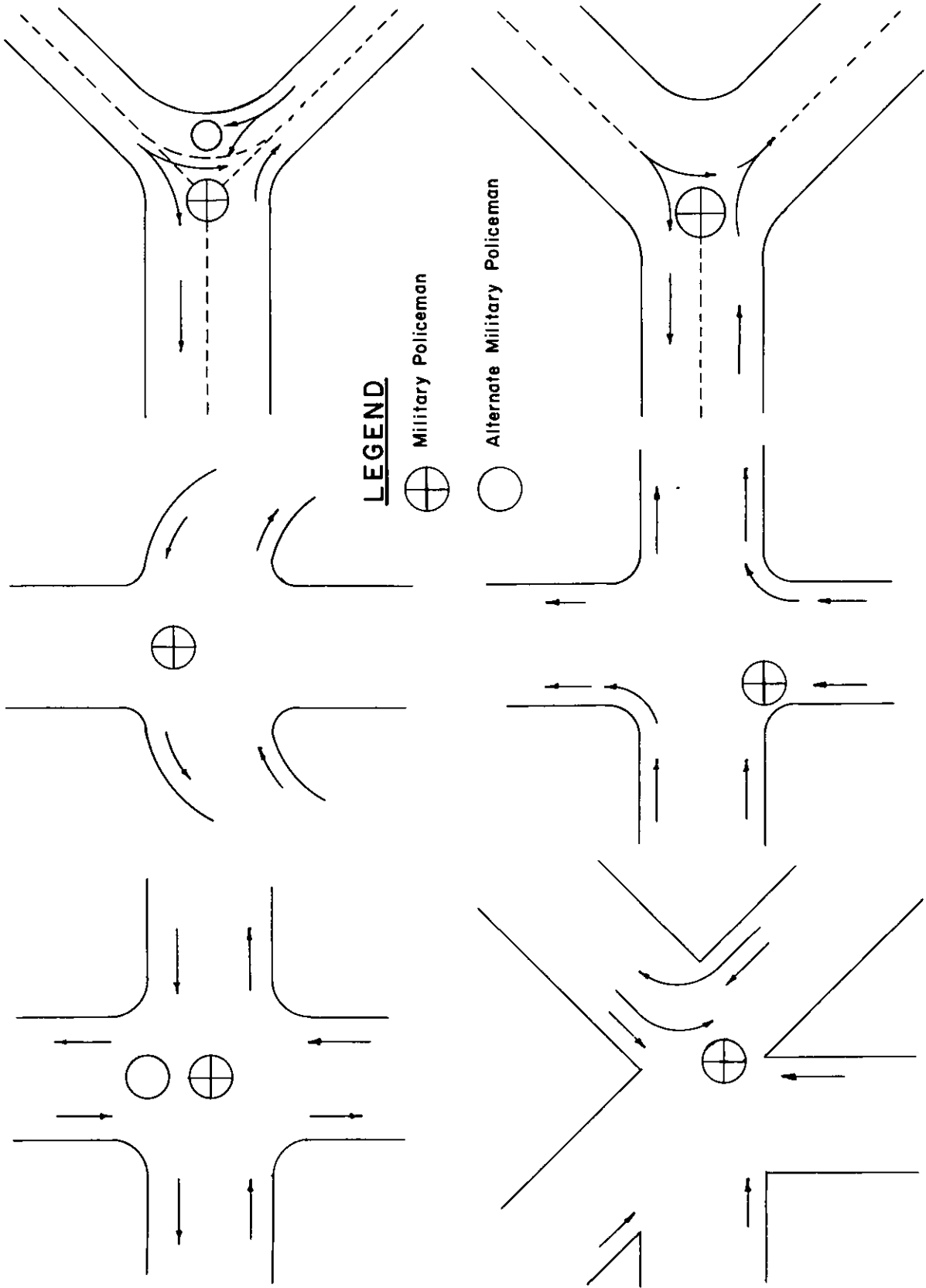


Figure 17. Military police ground orientation. Typical positions at various intersections. The position is not fixed and the military policeman may move to meet traffic flow needs.

- (2) A raised platform which allows the military policeman to be easily seen by drivers and provides him with a better view of the traffic.
- (3) Temporary signs and road cones which assist in directing the traffic flow and calling attention to the existence of the control point.

39. Ground Orientation

a. The location at which the military policeman stands for the greatest effectiveness depends on the design of the intersection, traffic characteristics, light conditions, and the degree of control required. It is important that the military policeman be seen by approaching traffic, that he can see approaching traffic, that he will not interfere unduly with traffic, and that maximum personal safety is assured. At many intersections this point is the center of the intersection. Sometimes it is better to position the military policeman to one side of the main flow—at T or offset intersections, or other irregular intersections, when there is one-way traffic, or when the road is unusually narrow (fig. 17).

b. When two or more men work together at a control point it is imperative that one be in charge. Additional men may be used to control major secondary movement at the control

point, such as movement from a parking lot, pedestrian traffic, at a wide divided roadway, or at any intersection where complex movement occurs (fig. 18).

40. Hand Signals

Hand signalling is a basic technique used to perform point control of traffic. Specific signalling techniques have been standardized.

a. *Daytime.* Under normal conditions of visibility, standard military police hand signals are used (app. III). Slight modifications may be made in signalling techniques to accommodate foreign drivers who are not familiar with U.S. Army military police hand signals. Non-standard or poorly executed hand signals tend to confuse drivers and to destroy the effectiveness of the traffic control point.

b. *Nighttime.* Signals used at night are normally executed by using a traffic baton or flashlight. Although they serve the same purpose, the signals are different from daytime signals and must be learned thoroughly by both the military police and the drivers of vehicles. All signals given at night must be executed slowly and deliberately. Any changes to the basic signals used by military police must be widely publicized to drivers; otherwise, dangerous situations may result from the failure of drivers to understand signals (app. III).

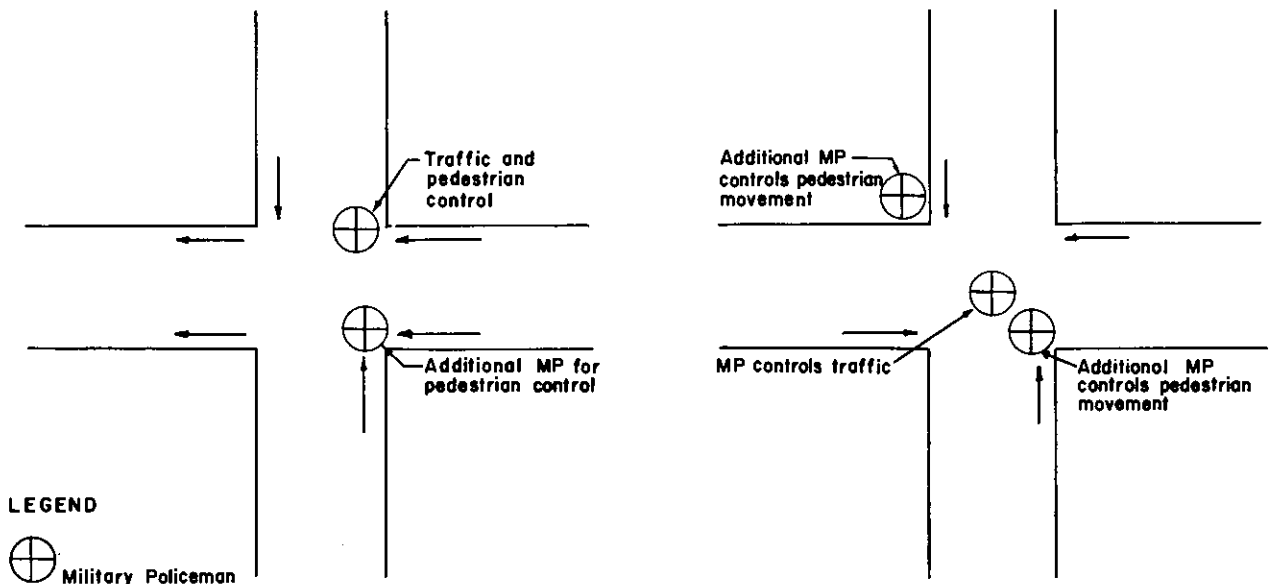


Figure 18. Military police ground orientation. Typical positions at various intersections using more than one military policeman.

c. Use. When using hand signals the military policeman must be able to apply the following basic rules:

- (1) The primary rule in executing any signal is to LOOK, EXECUTE, and COMPLETE each signal separately.
- (2) Assume a correct stance for controlling traffic which will help to reduce fatigue and present a good appearance (fig. 19).
 - (a) The body should be erect, with feet approximately 8 to 10 inches apart.



Figure 19. Correct stance for military policeman controlling traffic.

(This distance is dependent upon the height of the individual military policeman.)

- (b) Arms should hang naturally by the sides.
- (c) The weight of the body should be balanced on both feet.
- (3) Keep the sides of the body toward the moving traffic.
- (4) Prior to executing a traffic control signal look at the traffic to insure that the driver can respond to the signal without confusion or danger.
- (5) Prior to instructing a road user to move or turn, insure that conflicting traffic is stopped. Since the military policeman is controlling the traffic he must be responsible to insure that the movement he directs is safe, as the driver is relying on him for a safe move.
- (6) Execute distinct and complete signals. Each movement made by the military policeman must be understood by the road user. If it appears that the road user does not understand the signal it should be repeated. The military policeman must not change his visual instruction once the signalling movement has been started.

41. Manual Operation of Automatic Traffic Signals for Point Control of Traffic

a. Traffic signal lights are automatic signals for point control of traffic. These signals normally work on a time sequence. During peak traffic hours, such as the beginning or end of the work day, it is often necessary to change the time sequence. This may be done by having the military policeman control the lights; however, this is a costly method; most traffic signals are adjusted for peak hours. If the signal lights cannot be manually controlled it is safer and more effective to turn them off, and use the hand signals, than to direct traffic in conflict with the signal lights.

b. Other types of mechanical control devices are available, such as metal "stop" and "go" signals.

c. The principles and rules outlined as a guide for the manual point control of traffic are applicable to the mechanical devices.

42. Whistle

a. In addition to the visual means of traffic control the military policeman is supplied with a whistle for audio assistance. The whistle is used to call drivers attention to the signal the military policeman gives or to warn the driver of impending danger. When constantly used for routine signals the effectiveness of the whistle is lost.

b. The standard whistle signals are:

- (1) STOP, one long whistle.
- (2) GO, two short whistles.
- (3) ATTENTION, several short (approximately 4) whistles, repeated as necessary to get attention.

43. Expediting of Traffic

a. The military policeman must know how to recognize signs of an impending traffic jam. These signs include but are not limited to the following:

- (1) Back-up of long lanes of traffic.
- (2) Excess changes in speed from slow to fast and back to slow by the moving lanes of traffic.
- (3) Vehicles blocking part or all of the intersection.
- (4) Minor rear collisions.

b. When the military policeman recognizes these signs he must hold traffic (or certain lanes of traffic) until the situation clears. In many situations movements can be combined, and it should be necessary to stop a lane of traffic only when other traffic must cross it. When an exit lane fills up, no vehicles must be permitted into the intersection unless they use exit lanes which are free. When it is necessary to bring two incoming lanes of traffic together, to form a single outgoing lane, it is better to alternate the flow rather than to try to blend the two lanes together. Alternations should be long enough to permit a substantial number of cars to go through, thus minimizing the stop-and-go effect of short alternations. The elimination of turning movements speeds up through traffic, but this restriction must be used with care. Ve-

hicles will have to turn eventually, and arbitrarily shunting turning movements onto the next intersection may greatly increase the control problem at that location.

c. Primary movements are maintained on the major road. When providing for alternation the military policeman will allow maximum "go" time to the major road. When traffic backs up on the major road, the flow from the secondary road should be stopped and the major road flow allowed to proceed even if all traffic on the secondary road has not cleared. The following additional rules should be applied when changing the flow of traffic:

- (1) Traffic from the secondary road will be allowed to proceed during breaks in the traffic on the main road.
- (2) If breaks do not occur on the main road, traffic from the secondary road will be allowed to accumulate prior to being directed to enter or cross the main road. This may result in comparatively longer waiting time for traffic on the secondary road (fig. 20).
- (3) A change in flow should be made without having traffic stop in or block the intersection.
- (4) A change in flow should not be made just prior to heavy equipment entering the intersection. Ideally the first few vehicles waiting for a flow change should be sedans or light vehicles that do not require excessive distances to build up speed. This allows maximum "go" time.
- (5) Right turns from the stopped flow are permitted whenever they do not interfere with the "go" flow traffic (fig. 21).
- (6) Right turns from the "go" flow traffic are permitted when not in conflict with pedestrians.
- (7) Left turns will be placed into "go" flow as follows:
 - (a) From a two lane road integrate left turns driving in opposite flow or stop opposite flow to allow left turn so through traffic can proceed.
 - (b) From a 3- or 4-lane road, with designated left turn lanes, left turn traf-

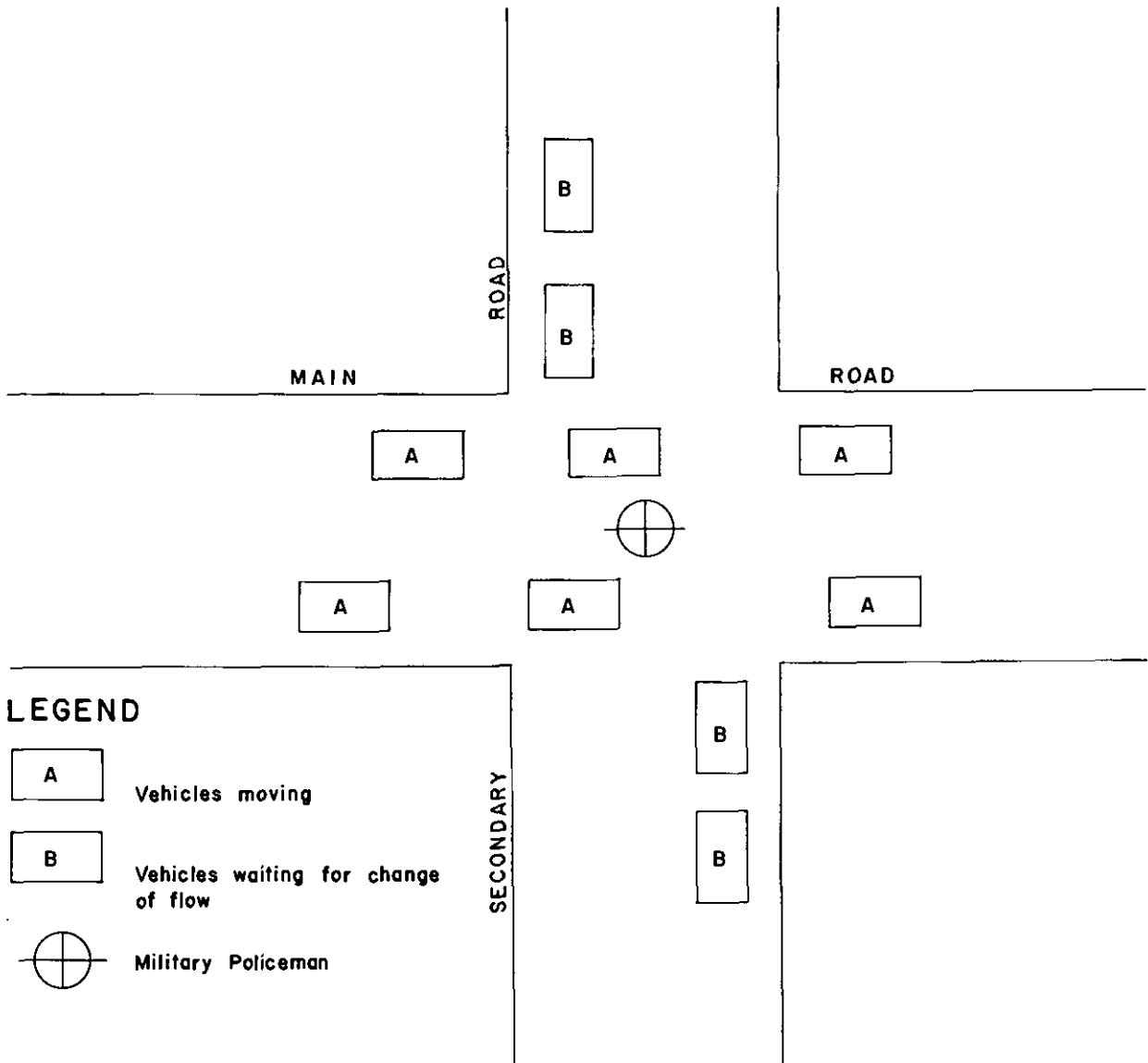


Figure 20. Traffic flow at an intersection.

fic should be stopped until the through traffic has cleared the intersection or a suitable break in the flow occurs. The left turn should then be cleared before the traffic flow direction is changed.

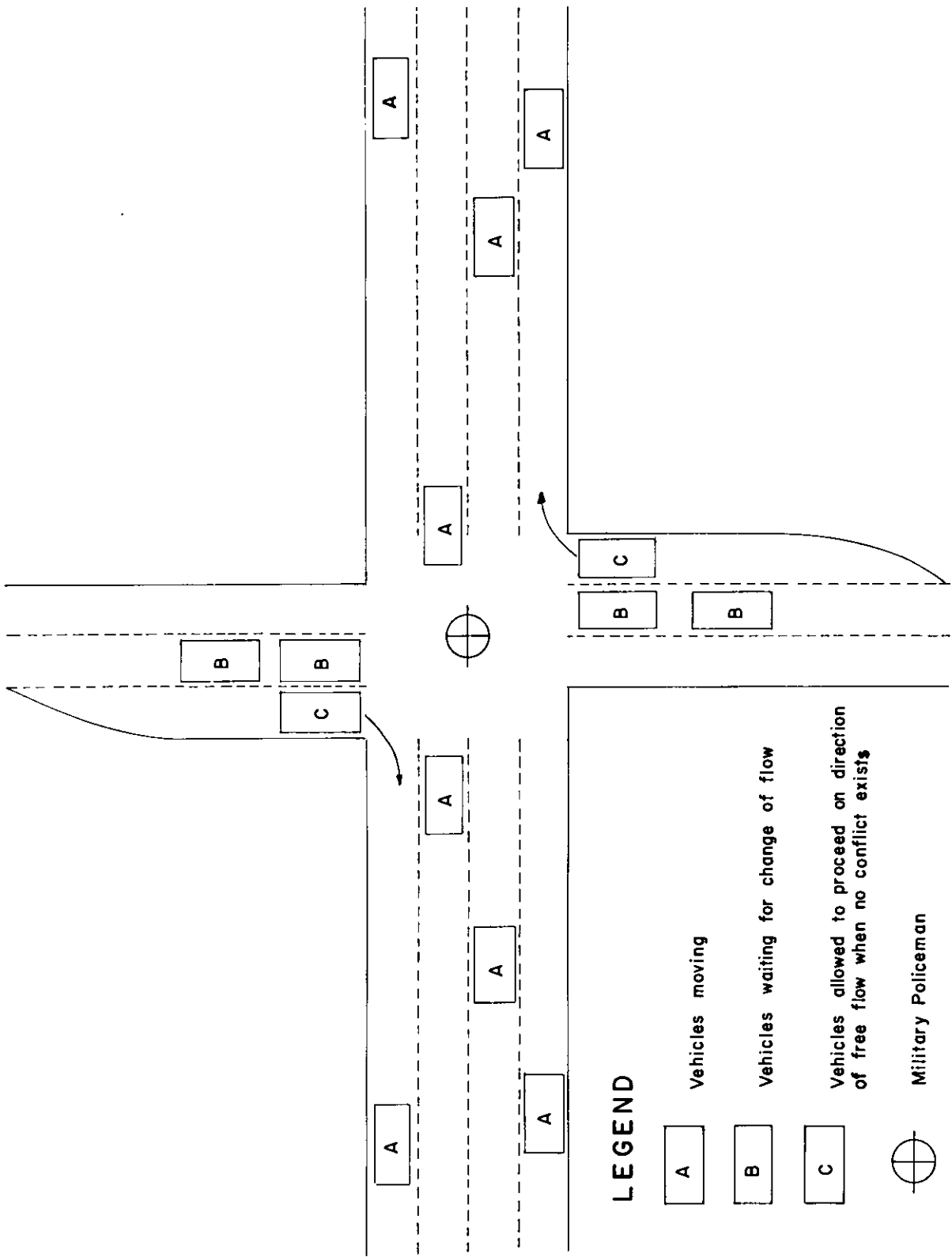
- (c) Caution should be exercised since the movement of the new "go" flow traffic may have its exit road filled with vehicles which had just completed the left turn.
- (8) Blending turning movements should be permitted only when there is no

conflict of lane use. This usually occurs when the intersection connects only 4 lane roads.

- (9) For examples of turning movements see figure 22.

44. Coordination Within the Traffic Flow System

Smooth and efficient traffic flow depends in part on coordination with other control points. Forcing or restricting turns, to keep one intersection open, may not be in accordance with the area plan and may create problems at



LEGEND

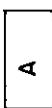

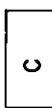

-  Vehicles moving
-  Vehicles waiting for change of flow
-  Vehicles allowed to proceed on direction of free flow when no conflict exists
-  Military Policeman

Figure 21. Traffic flow—right turns.

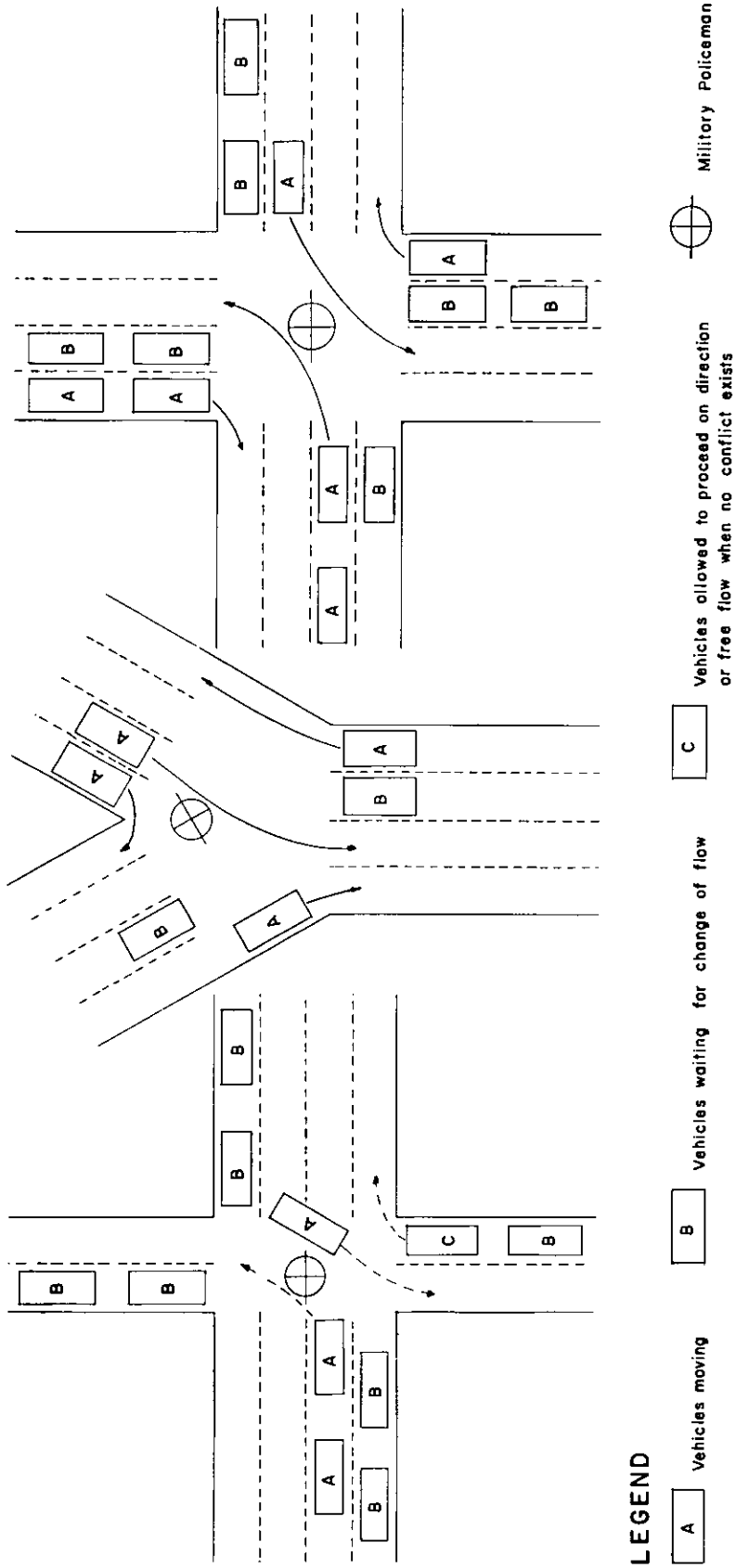


Figure 22. Traffic flow—turns. Various turns can be permitted provided they do not conflict with other movements.

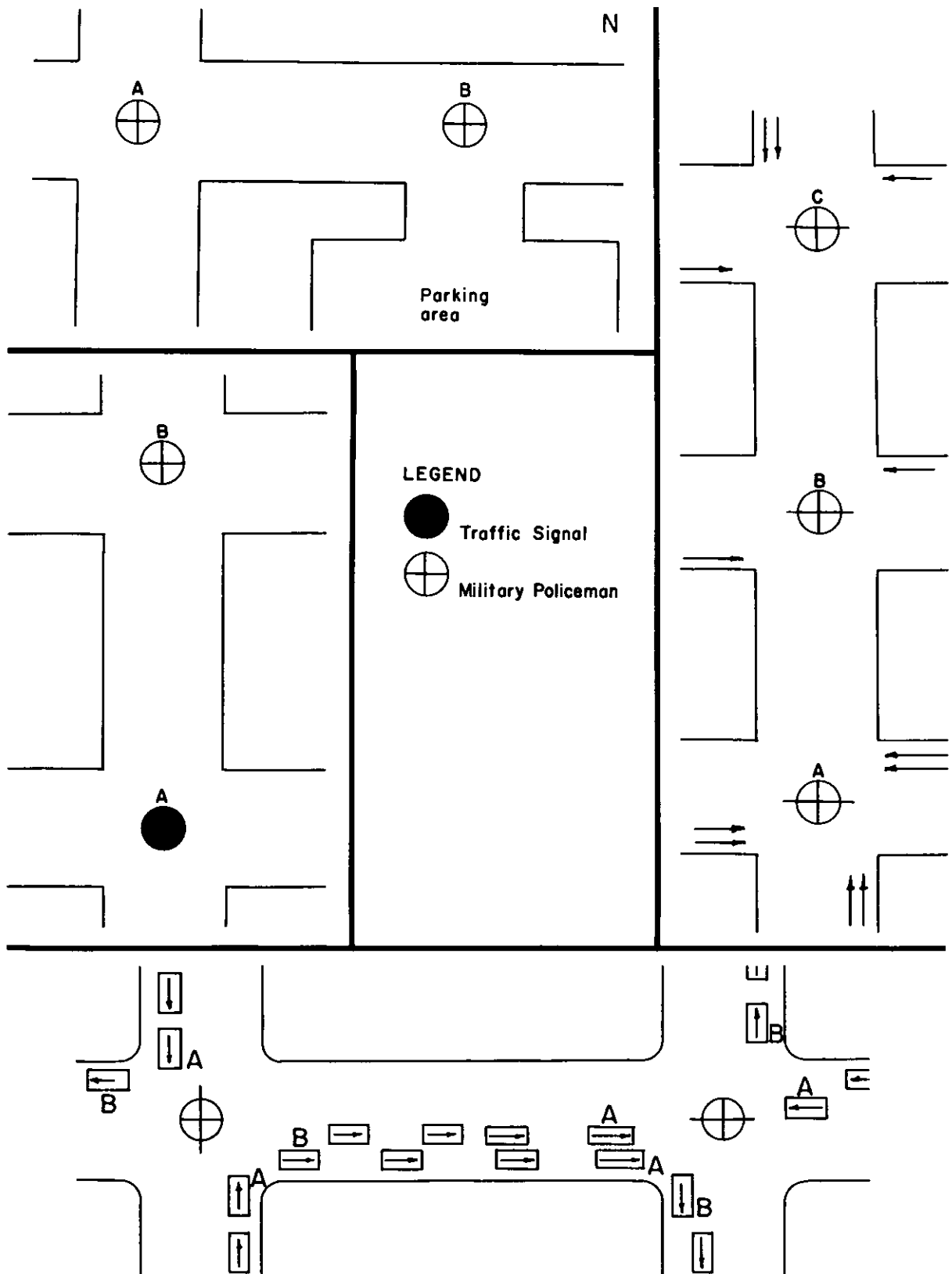


Figure 23. Examples of coordinated traffic flow. In the figure above position "A" is the major intersection. Military policemen at positions "B" and "C" regulate the traffic flow so that it is synchronized with position "A".

other points. To maintain an even flow, each control point must be synchronized with adjacent and nearby control points. Where a major control point is regulated by traffic signals, adjacent points should regulate flow to take maximum advantage of the signal alternations. Where there is no signal in use and a group of control points must work cooperatively, one control point should be identified as the key point, and adjacent points should coordinate their flow with it.

45. Special Point Traffic Control

a. One of the most important special control points will be at school crossings. General traffic control principles are applicable; however, due to immaturity and lack of safety knowledge, school children require special control measures. The military policeman must be aware that children's actions are impulsive and that they must be constantly observed. At school crossings the military policeman should apply the following principles:

- (1) Whenever possible, face the majority of the children so as to keep them in view.
- (2) Cause motor traffic to move through the crossing with caution.
- (3) If school safety patrols are employed, insure that they are performing their duty properly.
- (4) Before allowing traffic to move, insure that the children are complying with his signal for them not to cross the street.

b. Emergency entrances to such facilities as hospitals and fire stations require adjustment of traffic point control to meet special situations. The most common adjustment will be the sudden change in traffic flow. The military policeman must respond quickly to the approach of any emergency vehicle with a minimum of confusion. The guides presented in this chapter, and the application of common sense can solve the problems that may arise at emergency entrances.

CHAPTER 4

MOTOR PATROLS

46. General

Military posts with good road nets, and road users who are trained to comply voluntarily with laws and regulations, lend themselves to the use of motor patrols as the main means of traffic control and reduce the need for point control of traffic.

47. Equipment

a. The term "motor patrol" implies the use of a motor vehicle to accomplish the patrol mission. Whether the vehicle is a jeep, a sedan, or other type of vehicle, it is the responsibility of using military police to perform the first echelon maintenance. It is necessary for the accomplishment of the traffic control mission that the vehicle be ready for immediate use. Appropriate technical manuals provide guidance for maintenance of all equipment. The cleanliness of the vehicle, while part of the maintenance program, is also good police public relations and contributes to the public support of the traffic control program.

b. Radio communication is an integral part of standard equipment for a military police motor patrol. To be effective, a motor patrol must be capable of two-way radio communication with the military police station, the patrol supervisor, and all others in the military police net. The military policeman using communication equipment must perform his portion of the maintenance as outlined in the technical manual published on the equipment.

48. Special Items of Equipment

The following special items of equipment used by motor patrols are in addition to the equipment mentioned in paragraphs 38 and 47. Other items may be added depending on the

task to be accomplished and availability of funds.

a. Warning equipment is mandatory to provide safety to the road user and the military police. Warning lights and sirens are normally mounted on military police vehicles. Flares, portable lights, safety cones, signs and other such items are issued to patrols through supply sources.

b. First aid equipment and blankets are considered the minimum emergency equipment to provide first aid under normal conditions. When the need for first aid appears, the average road user turns to the military police. To meet this requirement the military policeman must have at least the minimum equipment, and know how to use it.

c. As a minimum the military police patrol should have a carbon tetrachloride fire extinguisher in the patrol vehicle.

d. All patrols should have certain equipment for use at accident scenes. This would include ropes, crow bars, axes, shovels, pickaxes and brooms modified so that they can be carried in the vehicle. Handtools and jacks, normally organic to the vehicle, may also be used at an accident scene. When military-type vehicles are in use, the pioneer tools of the vehicles may be used to replace some of the equipment indicated above.

e. Equipment to assist the military policeman in preparing his written reports ranges from clip boards to specially designed desks for vehicles. Means to insure that patrols have the necessary forms to perform their duties are normally developed by the local unit.

f. The general public normally looks to the military police for assistance and for proper

direction to any given area or facility. To perform this function properly, the patrol must be equipped with maps, directory, and other general information. This public service function is an important service and is a source of favorable public relations for the military police.

49. Patrolling

a. An important mission of the motor patrol is to encourage voluntary compliance with all the laws, with emphasis on compliance with traffic laws, rules, and regulations. In addition, the patrol supplies information, assistance, and services; it reports traffic violations; performs traffic reconnaissance; provides emergency escorts for emergency vehicles and convoys; assists traffic control personnel at fixed posts; and aids at accident scenes. By their presence the patrol aids the command accident prevention program.

b. The motor patrol is normally made up of two military policemen: the driver and the senior military policeman. The title "driver" adequately describes the principal duties of the first military policeman. The requirement for safety and the goal of all military police, which is to set the example while patrolling, restricts this military policeman to operation of the vehicle when it is in motion. Otherwise, he performs normal military police duties.

c. The senior military policeman's duties include the direction of the driver; observation of traffic; and performance of other military police type duties such as physical security and prevention of crime.

50. Methods of Patrolling

a. Parked.

- (1) The patrol generally parks where drivers can see the military police vehicle. This practice will support and encourage voluntary compliance. When using this method, a location should be selected that insures the driving public will see the patrol. The military policeman should give the appearance of being alert and attentive to the traffic. The site selected should

allow easy entrance to the traffic flow. Further, the site should be on a road that has a volume of traffic to merit the expenditure of manpower, or at a location with a high accident experience. It is mandatory that when patrols are engaged in this activity they have and maintain communication with the military police station.

- (2) The practice of having patrols hide behind billboards or in like areas will create a poor impression of police action on the driving public. Such action violates the goal of preventive enforcement—that of encouraging voluntary compliance with traffic rules and laws.
- (3) The two limitations inherent in a parked patrol are that it reduces the military police crime prevention activity and restricts the reconnaissance activity.

b. Moving.

- (1) Moving with the stream of traffic is the most common method of patrolling. This means that the patrols enter the main traffic lane, maintaining the speed of the traffic as long as it is not in excess of the speed limit or endangering. The main disadvantage of this method is the low exposure to the driving public, and the lack of opportunity for observation because of vehicle movements. It is used mainly in moving from one area to another area, while on reconnaissance, or when performing a crime prevention activity.
- (2) Moving slower than the speed of the traffic or the posted speed limits allows the military police to observe both road conditions and the surrounding area. Slow-moving patrols are useful in built-up areas; however, when this type of patrolling is used on the open road it has a tendency to slow up the normal traffic flow often causing traffic congestion and creating traffic hazards. Military police vehicles should keep to the right and permit faster moving traffic to pass. Patrolling faster than the normal flow of traffic is

a violation of the basic goal of all military police to encourage voluntary compliance with laws. It also disregards sound safety procedures and is normally not an acceptable method of performing motor patrol duties.

c. Other Methods of Motor Patrolling. The military police patrol may combine the circulation through its area with parking at certain locations during a tour of duty. The location to observe traffic and the area to patrol are determined as a part of the traffic control plan. When instructions are not specifically issued, the patrolling techniques will be based on the experience of the military police and on an irregular pattern, coordinated with the patrol supervisor and military police station. Some traffic control plans will schedule places and times at which the patrol will perform point control duties.

51. Information Function

The information function of a motor patrol is similar to that of a traffic control point. The motor patrol, with its capability to store reference material, exceeds the capability of the individual to adequately perform the information function. Items needed to perform an information function are listed in appendix IV.

52. Road and Safety Reconnaissance

The military policeman on patrol is constantly alert for road and safety hazards. Observations will be recorded and reported to the military police station. This provides a flow of information that enhances the success of the entire traffic program. The traffic control plan will schedule the reporting of most informa-

tion. When a radical change in traffic, road or safety conditions takes place, the military police will make an immediate report of this change. Observations to be reported include but are not limited to the following:

a. Changes in the volume of traffic, the time of the day that "rush hour" traffic occurs, the direction that traffic moves, roads used by heavy traffic, the opening or closing of a facility that generates traffic such as a PX or a playground, and the effects of any change on the traffic plan. If the military policeman fails to report this type of information, he detracts from the effectiveness of the traffic control plan. The receipt of this information provides the planners at the military police station data on which to base future plans.

b. Road maintenance is a function of the Engineer; however, since the military police are constantly on the road, they may be the first to note road deterioration. The military police will report such conditions as damage from storms, "pot" holes, obstructions such as tree limbs, and other general damage. The military police should observe and report all road construction, degree of obstruction, and the time and date the construction is completed.

c. Traffic signs are a tool for the control of traffic. Included in the term traffic signs are road markings, such as cross walks and center strips; these require the same reports as road signs. To be effective, markings must be in a good state of repair and easily visible to road users. The military policeman must be alert to the status of signs. On a scheduled basis, the motor patrol will conduct an inventory of signs.

CHAPTER 5

TRAFFIC ENFORCEMENT

Section I. INTRODUCTION

53. Traffic Violations

a. Definition. A traffic violation or offense is broadly defined as the commission or omission of any act prohibited or required by rules, regulations, or laws governing the conduct of traffic. Unlike many other offenses, traffic offenses do not ordinarily involve the question of intent. Common traffic violations are listed in figure 24.

b. Application. Traffic violations do not exist, for enforcement purposes, until they have been detected by the military policeman and enforcement action is taken. Involved is an interpretation by the military policeman as to proper and improper behavior. In order to assist in promoting proper behavior among the users of the

road it is necessary to have uniformity of enforcement.

54. Military Police Enforcement of the Law

a. The way in which military police enforce the law is the most important single guide to many drivers as to what behavior is acceptable and what behavior is not. To such drivers a traffic violation is only that behavior for which he must account to the nearest military policeman. The military police, by observation and with the use of special equipment, determine the action of the road user and make a comparison of this action with what is stated in the law. If this comparison reveals a conflict, then a traffic violation has taken place.

Category SPEED		
<i>Offense Title</i>	<i>Explanation of Offense</i>	<i>Remarks</i>
Speeding	In excess of the posted speed limit or at a speed not reasonable and prudent under conditions then existing. (Driving too fast for road conditions.)	
Driving Too Slow	Driving below the minimum posted speed, or impeding traffic. Under conditions when it is not reasonable and prudent to do so.	

Category TURNS		
<i>Offense Title</i>	<i>Explanation of Offense</i>	<i>Remarks</i>
Executing U-Turn On Roadways	Prohibited unless authorized by traffic signs.	
Improper Turn	Wide turn at intersection, turn from the wrong lane, or other unsafe turn under existing conditions.	

Figure 24. Table of Common Traffic Violations.

Category
PASSING

<i>Offense Title</i>	<i>Explanation of Offense</i>	<i>Remarks</i>
Passing in No Passing Zone	When proper road signs are posted and roadways are marked.	
Passing On Left	When the left side of the roadway is NOT clear of oncoming traffic or the roadway is not visible well ahead to the driver of passing vehicle.	
Passing On Right	Under conditions described in "Passing On Left," also passing on the right when prohibited by traffic laws and/or signs or when the passing would involve leaving the pavement.	See local SOP to insure that passing on the right is not prohibited.

Category
STOP

<i>Offense Title</i>	<i>Explanation of Offense</i>	<i>Remarks</i>
Failure to Stop For Stop Sign	When the operator fails to observe stop sign or fails to come to a complete stop.	This may also include stopping pass the stop line.
Failure to Stop For Stopped School Bus	When loading or unloading, vehicles coming from either direction must come to a full stop until bus resumes motion or its driver signals motorist to proceed.	Vehicles upon a divided highway may not have to stop when the school bus is on a separated roadway. Check local traffic regulations and SOP.
Failure to Yield Right-of-Way	At intersections when proper traffic signs are posted. If no signs are posted, failure to yield to the vehicle on the right, or vehicle entering first.	
Failure to Make Special Required Stops	Railroad grade crossing, existing from driveways, and private roadways.	Check local SOP and traffic laws.

Category
TRAFFIC CONTROL DEVICES

<i>Offense Title</i>	<i>Explanation of Offense</i>	<i>Remarks</i>
Failure to Comply With Signal of MP or Policeman	Same as title of the offense.	
Failure to Obey Traffic Control Devices	Traffic signal, special road signs, etc.	

Category
PARKING

<i>Offense Title</i>	<i>Explanation of Offense</i>	<i>Remarks</i>
Improper Stopping	Stopping on the roadway so as to block traffic; stopping so as to block two lanes of traffic; or stopping in a prohibited zone or area.	
Illegal Parking	Parking in space marked for no parking. Also improper parking, such as parked across yellow line which separates parking spaces, cross walks, too close to fire hydrants, etc.	Check local SOP and traffic laws.

Figure 24.—Continued.

Category
ADMINISTRATIVE REGULATION

<i>Offense Title</i>	<i>Explanation of Offense</i>	<i>Remarks</i>
Improper Use of Sound Device	Use of a horn, bell, etc., so as to create a disturbance, or in a posted "Quiet Zone" without cause.	
Failure to Comply With Vehicle Equipment Laws	Where prohibited by laws, and regulations the use, mounting or displaying of colored lights, the equipping of a vehicle with muffler cut outs, sirens, whistles, etc., or the failure to equip a vehicle with required equipment.	
Operating a Vehicle Without Valid Registration and/or Displayed License Plate(s)	Failure to comply with appropriate civil laws.	
Operating Motor Vehicle With Defective Equipment	Headlights, tail lights, brake lights, turn signals, muffler, horn, brakes.	
Overloading Vehicle	Failure to comply with regulations or appropriate vehicle TM.	
Failure to Comply With Post Vehicle Regulations	Failure to comply with Post Registration and inspection requirements; also failure to maintain in force the required minimum vehicle insurance; failure to notify the PM of change of vehicle status (new state license etc.).	
Driving Without a Valid Operator's Permit	Failure to obtain permit or driving after suspension, revocation, or withdrawal of driving permit (license).	
Permitting Unlicensed Operator to Operate Vehicle	To be charged against owner when a non-owner driver is charged with preceding offense.	
Driving a Vehicle With Obscured Vision	Excessive snow or ice on windshield; unauthorized stickers on windows and any object inside the vehicle which may obscure the operator's vision; inoperative windshield wipers.	

Category
ACCIDENTS

<i>Offense Title</i>	<i>Explanation of Offense</i>	<i>Remarks</i>
Leaving or Fleeing the Scene of an Accident	Failure to stop, make identity known and render aid to injured.	Usually referred to MP CID.
Inattention	Not giving full time and attention to driving.	
Misjudging Clearance	The act of driving too closely in passing, entering, approaching a vehicle, person or object.	Usually connected with an accident.
Following Too Closely	Not maintaining a safe stopping distance, considering the speed of the vehicles and condition of the highway, behind the vehicle ahead.	Usually connected with inattention.

Figure 24.—Continued.

Category
MISCELLANEOUS

<i>Offense Title</i>	<i>Explanation of Offense</i>	<i>Remarks</i>
Improper Backing	The rearward movement of vehicle that cannot be made with reasonable safety and without interfering with other traffic. With military vehicles, failure to use a guide.	
Improper Signal	Failure to give proper signal prior to making turn, stopping, passing, and starting.	
Drunken Driving	When the operator has consumed enough liquor or drugs to impair the rational and full exercise of his mental and physical faculties to affect his ability to control the vehicle he is operating.	
Driving the Wrong Way On One-Way Street	Failure to comply with posted road signs and/or road markings.	
Driving On Wrong Side of Roadway	Failure to keep vehicle to the right side of the roadway or in the proper traffic lane.	
Reckless Driving	Operating a motor vehicle in a heedless and dangerous manner which may endanger lives or property.	
Failure to Dim Lights	Failure to dim lights to oncoming vehicles and at any time when within certain defined areas.	Check local SOP.

Figure 24.—Continued.

b. The goal is for all military police to take uniform action for the same violation under the same conditions. However, several factors exist for which precise measurements have not been developed. Only by the training and experience of the military police can these factors be prevented from adversely affecting traffic enforcement. These factors include the military policeman's ability to—

- (1) Detect and identify unusual or illegal behavior, or those conditions which produce or accompany such behavior. Examples would be drunken driving or driving too fast for conditions.
- (2) Evaluate the legality or illegality of such behavior or conditions, interpreting on the spot all applicable law, in light of the circumstances prevailing.
- (3) Apprehend a violator under adverse conditions.
- (4) Apply tolerances and determine the nature of evidence which can be developed to support charges.

c. In enforcing traffic laws it is necessary for the military policeman, once he has observed

an offense, to take immediate action. This action must be taken consistent with the safety of both the public and the military policeman. Failure to take such immediate action leads to other violations, accidents, and beliefs by drivers that enforcement is lax or ineffective.

55. Selective Enforcement

a. The presence or the implied presence of the military police, coupled with the drivers' belief that apprehension will follow any traffic violation, will tend to deter violations while assisting in achieving the goal of enforcement. Distribution of military police personnel and equipment is planned so that the enforcement effort is applied where and when it is needed. This application of enforcement is called selective enforcement. It may take the form of assignment of military police to a specific location at a given time. Another form selective enforcement may take is the announcement of certain driver violations which have contributed to recent accidents or increased congestion.

b. The normal basis for the selective enforcement program is the reports and information

that originate with the military police. The whole program is dependent on how the military policeman performs his duties and how accurately he reports what he observes.

56. Enforcement Policies

Well defined policies must be established by the commander in connection with the enforcement program. These policies can best be described as tolerances which take into account human and mechanical fallibility and other considerations. Generally, these policies are adequate to take care of most cases, but in other instances the military policeman on the spot must decide on the basis of the specific situation. He must *not*, however, apply his own tolerances simply because he considers the traffic regulations overly lax or restrictive. Tolerances must never be made public. To do so will defeat the purpose of tolerances by tending to make the tolerated deviation a standard. It is almost impossible, in some cases, to draw a clear line between what is a violation and what is not; and often, where such definition is possible, it is neither practicable nor reasonable to enforce the letter of the law.

a. Speed Enforcement Tolerance. It is theoretically possible to measure speed to a fraction of a mile per hour. Technically, the offense has occurred when any vehicle exceeds the speed limit at any time. But human and mechanical errors make it difficult to be sure of the exact speed of a vehicle. In most cases a suspect has to be paced for a sufficient distance, and the military policeman must be following closely enough to be sure of a violation. It is a common practice of military police units to issue instructions to refrain from issuing citations for speeds which exceed posted limits by only a few (up to 5) miles per hour. This "leeway" does not weaken enforcement; it strengthens enforcement. However, if the individual military policeman adds other leeways the enforcement program will be weakened. It is not considered speeding for enforcement purposes if only a short burst of speed is used to get around a slow-moving vehicle. This decreases the time required to pass, and thus reduces the likelihood

of an accident. In accordance with this policy, however, such speed should not be excessive or used in a reckless manner, and must be reduced once safely past the overtaken vehicle.

b. Stop Sign Enforcement. Stop sign regulations require a full stop to be made at either a painted crosswalk or stop line, or prior to entering the intersection. For enforcement purposes, however, the exact point of stopping often cannot be determined. It is not always clear where the stop should be made, as for example, where the stop sign is placed some distance from the intersection and there is no painted stop line. Sometimes when two or more cars stop in a column, the second (and often the third) car may stop at or near the place required by law. When these cars move out after the stop, it is difficult for drivers to know if (or where) they should stop again. A full stop is difficult to distinguish from an "almost" or "rolling" stop, especially with automatic transmissions where a slight "creep" is not uncommon. There is no specific guide as to what constitutes a reasonable opening in traffic so that a movement from a full stop can be made into opposing traffic with safety.

c. Distances. It is necessary to allow a reasonable margin before taking enforcement action, to compensate for normal observational and judgment errors. It is not always practicable for military policemen to determine distances required by regulations. Examples of distance difficult to measure are following too close, the distance a turning signal is given before a vehicle turns, the distance from a curb, from an intersection or from a fire hydrant.

d. Time-Limit Parking. The enforcement of time-limit parking presents a technical problem of time measurement, and a practical problem of making frequent checks. It is possible, with precision watches, to check the exact time of arrival and departure of every vehicle. But it is not practical, so a few minutes over the time limit may be allowable. Making an enforcement check every 75 or 90 minutes will ordinarily assure good compliance in a 60-minute zone.

Section II. TRAFFIC VIOLATIONS

57. Violations

Problems of congestion, conflict, and parking are primarily solved through engineering, but there is much the military police do in the area of traffic control and particularly enforcement to provide relief for these problems and thus promote traffic safety. The best engineering and signs or other control devices are inadequate without supervision by the military police; lack of supervision is often an important indirect cause of congestion, conflicts, accidents, violations and delays. Adequate attention to the enforcement of laws which affect traffic flow, recognition of the relationship between congestion and "little" violations, and proper traffic direction are among those actions that military police take to insure traffic flow and safety.

58. Speeding

While speeding is not the cause of all acci-

dents it has a marked effect on the severity of accidents and congestion in which it is involved. The following methods are used to determine if a speeding violation occurred:

a. The Speedometer or "Pace" Method.

- (1) A vehicle suspected of speeding may be paced by following in a patrol vehicle at a constant interval, for a reasonable distance, approximately one-tenth of a mile. The military policeman matches the speed of his vehicle to that of the suspect vehicle, and notes the speed indicated on his speedometer when the distance between the vehicles appears to be consistent. After maintaining the consistent distance for 30 seconds he will again note his speedometer to confirm the first reading.
- (2) This method is subject to mechanical and human error.

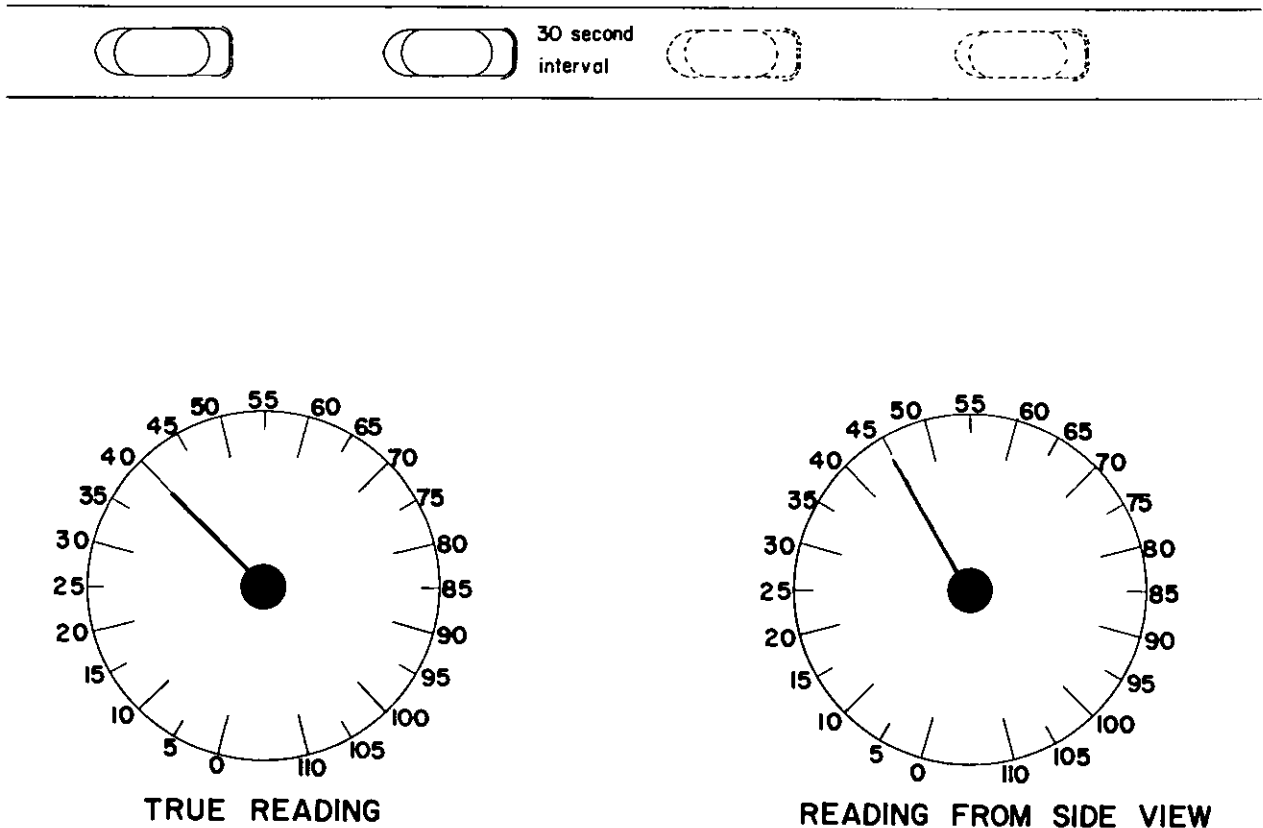


Figure 25. Example of a speedometer with and without distortion.

- (a) Speedometers are normally accurate. Mechanical error is reduced when speedometers are periodically calibrated. It is important that military policemen keep a valid record of calibration with the vehicle.
- (b) Human errors are corrected by training. The military policeman must accurately read the speedometer. No attempt should be made to read the speedometer without adequate light or from an angle which distorts the correct reading (fig. 25).

b. *Radar.* Radar equipment offers an accurate, efficient means of determining speeds at

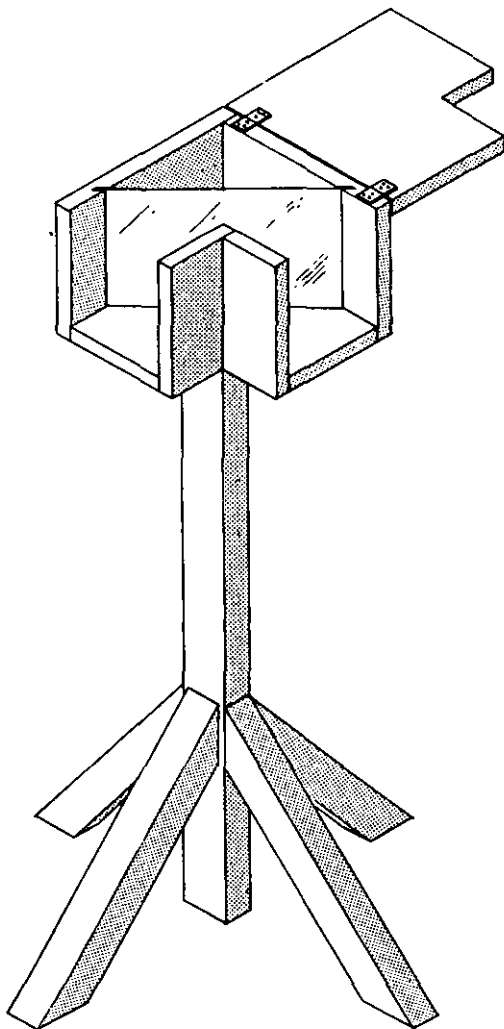


Figure 26. Mirror box.

which drivers pass a given point. In addition to the visual reading obtained by the operator, radar devices may be equipped to make graphic recordings of the speeds of passing vehicles. Instructions for operating specific types of radar equipment are provided by the manufacturers.

c. *Mirror Box.* The mirror box is an L-shaped box, with open ends, containing a mirror that reflects the image of a vehicle as it enters or leaves a measured course (fig. 26). Using one or two mirror boxes and a stopwatch, military police clock the vehicle passing through the measured zone. Two factors, time elapsed and distance travelled, are used to compute the speed at which the vehicle is traveling. The method is simple and accurate. The operator is provided with a tally sheet on which to record the speeds of passing vehicles. This sheet contains a table that translates time and distance factors into the speed of the vehicle in miles per hour (fig. 7). The steps listed in (1) through (7) below should be followed when using a mirror box:

- (1) *Select the place.* Select a straight stretch of level roadway. Measure

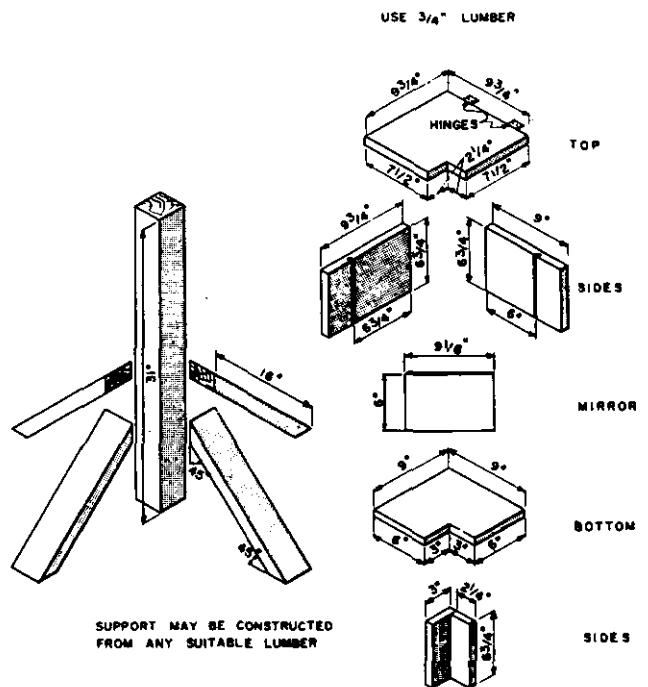
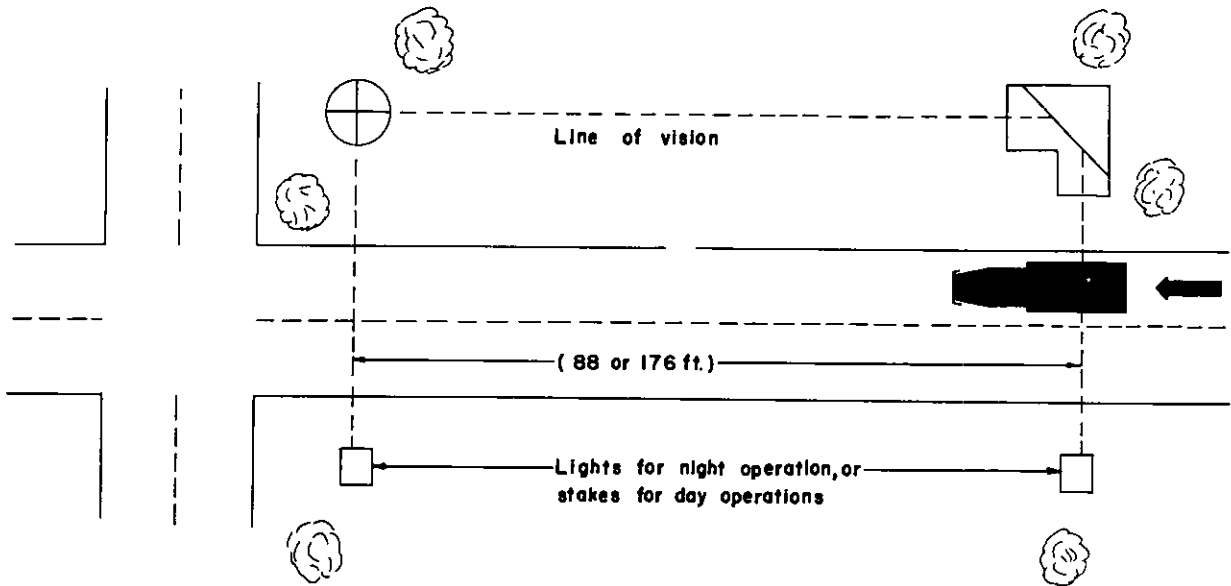


Figure 27. Dimensions of a mirror box.



LEGEND

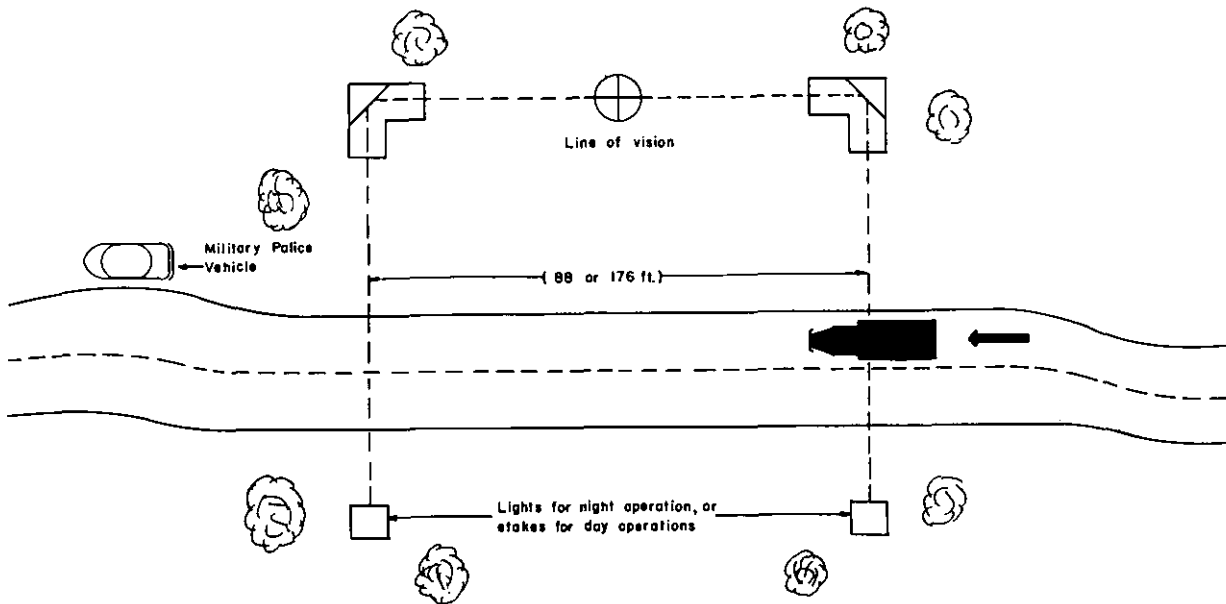


Military Policeman

Figure 28. Location of one mirror box and military policeman.

carefully an 88- or 176-foot line of sight course at a place where the military policeman has unobstructed vision of the road, but where he and the mirror box equipment are not unduly obvious to passing drivers. The site on which the equipment is to be placed should be approximately level with the surface of the road to be used.

- (2) *Determine the number of boxes.* One box is suitable for measuring speeds of vehicles on the approaches to intersections and, to a large extent, in any urban location (fig. 28). Two boxes are recommended for use with the 176-foot course because it is easier for the military policeman to see flash images in the two boxes (fig. 29). Two boxes used with the 176-foot course produce more accurate results, particularly when relatively high speeds are to be measured. Two boxes are also recommended when the speed of vehicles moving in both directions is to be measured.
- (3) *Install the equipment.* Each mirror box should be placed so that one open end points along an imaginary line across the roadway and the other open end points along an imaginary line along to the roadway. For daytime use, stakes should be placed alongside the road directly opposite each mirror box. At night, lanterns or other suitable sources of light should be placed in the same position prescribed for the stakes.
- (4) *Station the observer.* If one box is used, the observer should be at the end of the measured course away from the mirror box. He should be stationed so that he can see the flash images from the mirror box and also look directly along an imaginary line across the roadway. If two boxes are used, the observer should be stationed between the boxes so that he can observe the flash images from both mirror boxes.
- (5) *Begin operation.*
 - (a) *One box.* As a vehicle enters the measured course, a flash image in



LEGEND



Figure 29. Location of two mirror boxes and military police.

the mirror box will be visible to the observer. He should start the stop watch at the exact moment he sees the flash image and allow the watch to run until the front bumper of the vehicle crosses the end of the measured course. After he stops the watch, the observer should note the time it took the vehicle to run the course. He should then make a mark on the field sheet opposite the column indicating the time elapsed under the heading of the type of vehicle that was clocked.

- (b) *Two boxes.* The observer should look in the direction from which the vehicle is approaching and observe the flash image in the mirror box. He should start the watch at the moment he observes the flash image. He should then turn and observe the mirror box at the other end of the measured course. When the flash image (made by the vehicle cross-

ing the end of the course) appears in the mirror box, the observer should stop the watch, note the elapsed time, and record it on the field sheet.

- (6) *Special problem.* If two vehicles enter the course at about the same time, the observer should clock the first vehicle only.
- (7) *Uses of mirror box.* The mirror box may be used in the course of a survey to determine prevailing speeds (para. 28) or for the purpose of apprehending violators. When the mirror box operator has completed and recorded his calculations, he will, if apprehension is contemplated, notify other military police who have been previously positioned to make the apprehension (fig. 29).

59. Driving Too Slow

Driving too slow is not normally a direct cause of accidents; however, it may produce congestion and be a mediate cause of accidents.

Local traffic laws, regulations, and rules will define this violation. The method described in paragraph 58 may be used to determine if a driving-too-slow violation has occurred.

60. Improper Use of Lanes

a. The "lane straddler" blocks two lanes of traffic, and often compounds the offense by slow driving. Other drivers are unable to pass and thus traffic accumulates behind him.

b. The "lane hopper" is the driver who cuts in and out of traffic, weaving from one lane to another. This driver is not only a serious traffic hazard, but his erratic and unconventional behavior makes other drivers apprehensive of his actions. Traffic is thus slowed or stopped unnecessarily.

c. Military police detect these violations by observation of traffic.

61. Turning Movements

Turning from improper lanes or without signalling, turns made in prohibited places or in improper manner (as U-turns), or blocking a lane reserved for turning movement, are some of the movements which impede traffic. Turns which cannot be completed, when cutting across opposing traffic, and turns into or out of alleys or narrow driveways also tend to block the flow of through traffic.

62. Parking Violations

Parking violations can contribute to congestion. Double-parking, parking on the travelled portion of the roadway, parking in prohibited areas, and unauthorized stopping for loading or unloading are some of the obvious offenses and directly impede traffic flow. Other parking offenses serve to aggravate congestion by causing additional "cruising" by other drivers in search of parking space. Enforcement of time limit parking tends to make more spaces available.

63. Pedestrian

Violations by pedestrians often lead to, or aggravate, traffic accidents and contribute to congestion. Crossing at unauthorized places, crossing against signals, or non-observance of a military policeman's direction or of "walk" or

"don't walk" signals all tend to impede traffic. Pedestrians may crowd into the roadway, waiting for the traffic to change; at other times the continuous flow of pedestrians impedes the movement of vehicles. Compliance by pedestrians depends to a large extent on safety education. When enforcement has been used judiciously, the educational process has been markedly accelerated.

64. Drunken Driving

a. The Uniform Code of Military Justice, Article 111 makes punishable the operation of any vehicle while drunk. Drunkenness is defined in paragraph 191, MCM, US, 1951. The military policeman normally detects this violation by observation of unusual or abnormal driver behavior. Some examples are:

- (1) Extreme caution, especially low speed on through streets and highways, unnecessary stops where no stop is required, long stops at stop signs, or apparent confusion at intersections.
- (2) Failure to dim headlights or switching from dim to bright headlights when approaching other vehicles.
- (3) Lane straddling, speeding, or failure to signal a turn.
- (4) Moving over the center line, particularly when negotiating curves or approaching other vehicles.
- (5) Erratic movement such as weaving, driving in the wrong lane, or driving onto the shoulder of the road.
- (6) Repeated difficulty in engaging the gears of a vehicle or engaging gears with a loud clashing.
- (7) Swerving farther than necessary when passing another car or taking an unusually long time to return to the proper lane.

b. Supporting evidence for a drunken driving charge will be developed by the military police from observation and investigation. The military police duty officer, desk sergeant, or patrol supervisor may determine the need to request a medical examination of the suspect. In every case the military policeman must obtain as much information as reasonably obtainable in the investigation phase, by checking on when, where, and with whom the suspect drank; how

much liquor of what type he consumed; the suspect's driving behavior; conditions surrounding the accident or apprehension; and the physical or physiological condition (*c* below) of the suspect which might explain his behavior or apparent intoxication. The provisions of Article 31 of the UCMJ must be adhered to when developing information to support an apprehension for this offense.

c. Frequently the suspect will exhibit one or more signs of drug or alcoholic influence, such as the strong odor of liquor (although some liquors are relatively odorless), slurred speech, use of profanity, sloppy appearance, unsteadiness on his feet, and generally irrational behavior. Ordinarily, if these symptoms or appearances are due to liquor or drugs, the suspect is drunk (para. 191, MCM 1951). In his car or on his person there may be bottles of intoxicants. Many drunken drivers who have entered the dangerous driving stage do not exhibit such obvious symptoms. Any of the many symptoms which appear to be related to intoxication may be due to some chronic or acute illness or physiological condition (as diabetes, shock, amnesia, nervous disorders, speech disorders, muscular diseases, and so on).

If there is any indication that the suspected person is suffering from an illness, medical authorities should be contacted immediately.

d. A number of simple observations of the suspect's condition can be made at the military police headquarters or in some circumstances at the scene. These would include observations of balance; of coordination; of comprehension; of writing and of speech. Other than normal behavior does not necessarily assure that the reason for the defect in behavior is drug or alcoholic influence and not some physical ailment.

65. Other Violations

Attention to those principal violations which increase congestion must not preclude consideration of others which do not occur as frequently, but which collectively can become quite important. Among these violations may be: entering an intersection when the exit is blocked; failure to signal turns or stops; oversize vehicles or load above legal limits; blocking of sidewalks or alleys; alighting from vehicle on the street side; depositing debris on the roadway; improper backing; obstructing a driver's view; and bicycle violations.

Section III. STEPS IN STOPPING A VIOLATOR

66. Identification

When a violation has been detected the military policeman immediately attempts to identify the vehicle. This is done to locate the violator's vehicle in the event it becomes lost in traffic, as well as to provide evidence for subsequent administrative or disciplinary action.

a. The easiest means of identifying a civilian vehicle is by noting the state license plate. In recording this information it is advisable to include not only the number and letters but also the state, year, and color. If possible, this information should include the make and model of the vehicle, color and year of manufacture, military decals, attention-getting accessories, and vehicle damage, if any. The amount of identifying information obtained is dependent on time, conditions, and the experience of the military policeman.

b. The means of identification used for military vehicles closely follows that used for civilian vehicles. The bumper markings or military license plate are noted first. Because of the length of bumper markings the numbers should be recorded immediately. Additional desirable information includes USA number, type of vehicle, road clearance number (if used), vehicle classification, and other possible identifying features.

c. The military police should check their lists of stolen vehicles and wanted persons when a violator is identified.

67. Pursuit of the Violator

The most important consideration of the pursuit is safety of the military police and the public. To commence pursuit the military police patrol must enter the stream of traffic swiftly

yet safely. Overtaking the violator's vehicle is done as quickly as possible but not in a reckless manner. A radio report should be made to the military police station so that station personnel can perform their supervisory duties and, if necessary, assistance can be dispatched to the scene. Further, radio reports should be made at appropriate times; for example, when the violator's vehicle is halted, when assistance or information is required or when other developments indicate the need or desirability of keeping the station informed. As a minimum the immediate radio report should include as complete a description of the vehicle as possible.

68. Stopping the Violator

Selection of the place in which the violator is to be stopped is based on safety considerations; the place should be sufficiently large to allow for vehicles to park as described below. Signalling the violator to stop can ordinarily be accomplished by moderate use of lights and horn, although in some cases it may be necessary to use the siren or even to pull alongside the violator and give oral directions. During this action, constant attention should be given to warning other road users in an effort to preclude their confusion and to prevent accidents. Once the violator has been stopped the military police vehicle should be parked approximately 3 feet to the rear of the violator's vehicle and offset, to the left, approximately 2 feet. Warning lights must be left on as a warning to moving traffic.

69. Approach to Violator's Vehicle

The senior military policeman dismounts and approaches the vehicle from the right to observe the occupant(s) for indications of resistance or other action. The driver dismounts and stands alongside the MP vehicle while observing the left side of the violator's vehicle. The senior MP, upon determining that there is no indication of resistance or danger, moves around the rear of the violator's vehicle to the driver's side. At this time the other military policeman moves around the rear of the MP vehicle and stations himself to the right of the violator's vehicle so that he may observe all action within the suspect's vehicle. Neither military policeman should block the view or field of fire of the other. When approaching the driver's side of the vehicle the military policeman should stand away from the door so as to prevent being struck with the door by a driver resisting apprehension. Most traffic violators are not criminals but these precautions are required to protect the military policeman from the exception (fig. 30).

70. Dealing With the Violator

a. When dealing with a violator the military policeman maintains the highest degree of military courtesy and bearing. If the violator is an officer a salute will be rendered. Military titles, "Sir" or appropriate civilian terms will be used at all times.

b. The military policeman greets the violator, identifies himself, and informs the vio-

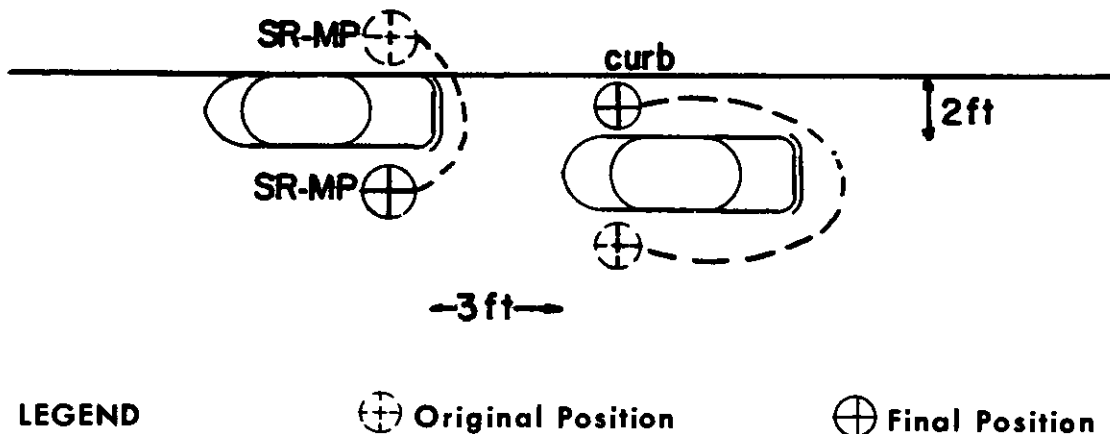


Figure 30. Approach to a violator's vehicle.

lator of the reason that he was stopped. An example is:

“Good morning, Sir, I am Pvt Doe of the post military police. I stopped you because you were driving 30 MPH through a 20-MPH zone. Sir, I would like to inform you that, according to Article 31 of the Uniform Code of Military Justice, you do not have to make any statement and that any statement you do make may be used against you in event of trial by court-martial.”

c. Normally, the violator may offer excuses, rationalize his action, or admit his guilt. The military policeman should allow the violator to talk. This will allow relief of the tension that normally builds up in an individual when he is stopped by the military police. During this period the military policeman requests driver's license, registration, and appropriate identification papers. The data on the appropriate documents must be checked. In his conversation with the violator the military policeman does not become belligerent and insures that he is not placed on the defensive.

d. Special care must be taken in the investigation of cases involving violators who are not able to understand the warning under Article 31 of the Uniform Code of Military Justice (for example, persons who are highly intoxicated). In such cases the violator's statements which are obtained by interrogation and the evidence gained solely from leads given in such statements may not be used in any disciplinary proceedings under the Uniform Code of Military Justice.

71. Enforcement Action

a. Next, the military policeman will take the appropriate enforcement action without wavering because of excuses or “reasons” for the violation, or letting the violator's personality or persuasion change his intended action. The military policeman informs the violator of the intended action, and proceeds to take that action. The action is completed when the violator is allowed to proceed, or in the case of a serious violation is apprehended and accompanied to the military police station.

b. When the appropriate action is completed the violator's documents are returned to him individually. An example is:

“Sir, here is your ID card, here is your license, and here is your registration. This is an Armed Forces Traffic Ticket, would you please note the instruction on the reverse side. Thank you, sir. Good morning.”

c. The military policeman must attempt to insure that the violator's vehicle returns safely to the stream of traffic. Ideally the violator's vehicle should be allowed to enter the stream of traffic without police control when a break in the stream occurs. When traffic is so heavy as to preclude this, the military policeman will safely stop traffic to allow the vehicle to enter the stream of traffic.

72. Written Warning

The military policeman will issue written warnings for those violations and under conditions which are outlined by local command policy. Written warnings, using the Armed Forces Traffic Ticket (DD Form 1408), are used since they form a record and serve as a basis for other military police or command action. The warning is a useful enforcement tool, but prescribed procedures must be closely followed to prevent the military policeman from assuming the duties of the commander and the courts. On copy number 2 of Warning Tickets the military policeman should enter in the remarks block the circumstances which prompted him to issue a warning rather than a citation.

73. Related Action

As in other traffic duties the military policeman performs other actions while stopping a traffic violator. This includes checks for stolen vehicles, pass and leave documents, license and registration, and other such actions as may be directed.

74. Witnesses

For serious violations the names and addresses of all personnel who witnessed the violation should be secured and recorded. It may be necessary in some circumstances to request written statements from witnesses. In such cases the military policeman himself should prepare a detailed written statement of his ob-

servation. It must be remembered that the MP's duty does not end with preparation and filing his report. He must be prepared to testify in court. His written statement will be of considerable value to the counsel preparing the case for trial.

75. Protection of Property

a. It is the responsibility of the military police to protect the property of each person apprehended so that it may be returned to the individual in the condition in which it was received. To provide protection to both the military policeman and the person apprehended all property will be inventoried and a chain of custody maintained.

b. When for a cogent reason a vehicle must be taken into custody by military policemen, the provisions of local policy must be strictly adhered to. Consideration in forming local policy would include extent of Federal jurisdiction, liability which may be incurred by the military when moving or storing a vehicle which has been seized; place of seizure, and conditions under which the vehicle entered the military reservation.

76. Reports

All enforcement actions of the military police are reported to the military police headquarters by written reports. The military police patrol report is used to record a summary of all

patrol activity to include traffic enforcement. Other traffic reports include—

a. The Armed Forces Traffic Ticket (DD Form 1408) form is used by all services to report traffic violations. Normally, a book of these forms, numbered consecutively, is issued to the military policeman and must be accounted for. They may be used to account for the following traffic violations:

- (1) Speeding.
- (2) Improper turns.
- (3) Disobeying a traffic control device.
- (4) Improper passing.
- (5) Improper lane use.
- (6) Following too close.
- (7) Failure to yield.
- (8) Other violations (usually listed in local SOP).

b. The Military Police Report (DA Form 19-32) is completed when the offense is serious. Examples of types of offenses reported on this form include drunken driving, failure to stop for military police, driving without a license, and reckless driving. It is not normal procedure to complete a DA Form 19-32 on a violation that is reported on an Armed Forces Traffic Ticket.

c. In recording traffic violations, either on DD Form 1408 or on DA Form 19-32, care must be taken that the conduct described as a violation is in fact a violation of the law, i.e., the Uniform Code of Military Justice or pertinent traffic regulations.

CHAPTER 6.

TRAFFIC ACCIDENTS

77. General

One of the functions of the military police is the investigation of traffic accidents. A major portion of the military police effort in this area, however, is devoted to accident *prevention*, rather than mere investigation and reporting. The military police traffic accident prevention activity, as a part of the selective enforcement program, is, in turn, an integral part of all command programs to prevent or reduce accidents.

78. Traffic Accident Causes

a. The efficient investigation of traffic accidents requires an understanding of accident causes and the events that take place during an accident.

b. There are three types of causes. These are recognized as *direct*, *mediate*, and *early* causes.

(1) A *direct cause* is any unconventional or hazardous behavior or negligence by a road user at the time of the traffic accident, which contributes directly to the accident. It could be called a behavior cause. Usually such behavior could be observed by the military policeman if he is a witness to the accident. There are four kinds of *direct causes*: speed, initial behavior, delayed perception and faulty evasive action.

- (*a*) Speed, greater or less than a safe normal speed, may be the direct cause in one of the following:
1. By making it impossible for a traffic unit to follow a desired curve.
 2. By making it impossible to take successful evasive action.
 3. By presenting an unusual element of surprise to other traffic units.

(*b*) Initial behavior or road position may be the direct cause in one of the following ways:

1. Unusual action, such as skidding or running into a ditch.
2. Illegal actions, such as driving on the wrong side of the roadway or walking diagonally across the roadway.
3. Hazardous actions, such as backing into the stream of traffic or double parking.
4. Improper actions, such as driving through a service station area to avoid stopping at an intersection.

(*c*) Delayed perception is the failure to see or otherwise perceive danger of an impending accident-causing situation as soon as would be possible for the normal operator in the normal vehicle under normal conditions. It nearly always involves inattention or distraction. Driving too fast for road and weather conditions should not be confused with delayed perception. A person may see a hazardous condition as soon as it is possible to do so, but may be unable to avert an accident because of speed.

(*d*) Evasive action is the reaction of a road user to a dangerous situation that has been perceived. Evasive action is always taken after perception. Through this action, many traffic accidents are averted. Sometimes it is merely yielding the right of way. It may be slowing, stopping, accelerating, or turning. With pedestrians it may be stepping back onto a curb or otherwise clearing a vehicle lane. Failure

to take the proper evasive action or taking the wrong action is a direct cause in some accidents.

- (2) A *mediate cause* is one that contributes to a direct cause. In each direct cause there may be one or more mediate causes. For example, skidding on a curve is a direct cause. The conditions that make it possible (mediate causes) are slippery paving, an urge for speed on the part of the driver, or a lack of skill in the use of brakes. Some irregular or unusual condition of a vehicle, the road, weather, driver, or pedestrian which explain one of the four direct causes is usually found as a mediate cause. They often appear in combination of two or more.
- (3) An *early cause* is an act or negligence on the part of some person or organization which creates a mediate cause or permits it to exist. It is sometimes referred to as a remote cause. For example, a vehicle skids on ice-covered pavement and collides with another vehicle. Skidding is unconventional or unusual behavior—direct cause. Slippery pavement due to ice—mediate cause. Failure by responsible authority to sand icy patch—early cause.

79. Six Stages of Accidents, or Chain of Events

a. Each traffic accident has a chain of events, or stages. Not all the links in the chain of events appear in every accident. However, every accident will have a *key event*. Three events come before the key. They are the point of possible perception, point of perception, and point of no escape. Two events occur after the key event. They are point of maximum engagement and point of rest or final position.

b. Events before the key event.

- (1) The *point of possible perception* is the time and place at which the unusual or unexpected movement or condition could have been perceived by a normal person. For practical purposes, this point always comes at or before the point of perception. "Delay in percep-

tion" or "perception time" is the time between the point of possible perception and the actual perception.

- (2) The *point of perception* is the point at which the road user recognizes a danger or realizes that something is wrong. It is not the point at which danger develops, because the danger may develop or exist before the person is aware of it. The point of perception is used to try to determine the road user's contribution to the accident. At or after the point of perception, the road user can, by taking appropriate action, possibly avert or lessen the seriousness of a traffic accident. Inattention on the part of the road user is probably the most common contribution to lack of prompt perception. Some traffic accidents do not have a point of perception, for example, when an operator falls asleep at the wheel.
- (3) The *point of no escape* is that place and time after, or beyond which, a traffic accident cannot be averted. Nothing the driver or pedestrian can do now will prevent the accident. A driver may be able to lessen the seriousness of the accident by slowing or braking his vehicle. The point of no escape may come at the same time as the point of perception. It may even come before the point of perception; for example, when a person's attention is diverted until just before the accident.

c. The *key event* is the most important event that happens to each traffic unit in an accident. There are three types of key events:

- (1) Collision. A common traffic accident involves two traffic units in a collision. The key event is when these units have made their first contact and is referred to as the "point of initial contact."
- (2) Noncollision. In this situation the traffic unit does not collide with another traffic unit. However, the key event always occurs on the road or

its shoulders. Examples of noncollision key events are:

- (a) A vehicle skids on a wet pavement, catches a wheel in a rut, then tips over in the road. There has been no collision. The key event is the wheel catching in the rut.
- (b) A soldier falls from a moving truck. The key event is the loss of contact with the truck.
- (3) Running off the traveled or usable portion of the roadway.

d. Events after the key event.

- (1) The point of maximum engagement follows after the key event. It is the time and position in which vehicles, pedestrians, or other objects in a collision are forced together as much as they will be. The position of the vehicles and other objects at this point is very important in reconstructing many accidents.
- (2) The *final position* is the place where those objects involved in a traffic accident finally come to rest. It is their position before anything is moved. The final position will not always be seen by the military policeman upon his arrival as vehicles may have been moved for safety reasons or persons may have been removed to medical facilities.

80. Classification

a. For the purpose of reporting accidents and maintaining accident records, all vehicle accidents are listed in one of the following classifications or combinations thereof:

- (1) Vehicle-vehicle.
- (2) Vehicle-fixed object.
- (3) Vehicle-pedestrian.
- (4) Vehicle-other.

b. For example, two vehicles coming into contact with each other would be a vehicle-vehicle accident. If one of the vehicles careened off the other and struck a pedestrian, the accident would be a vehicle-vehicle-pedestrian accident.

81. Preparation for Accident Investigation

a. Equipment available for the military policeman on traffic accident duty will be as prescribed by TOE, TA, and local policy. Following is a list of basic items for traffic investigation duty. This listing takes into consideration additional functions performed at the accident scene.

b. A vehicle is essential. It is highly desirable for it to be equipped with a siren, red or blue light, spotlights and a two-way radio.

c. Fire extinguishers, first aid material, a blanket, electric torch or lantern, flares, and a container of sand are desirable. Warning flags, stanchions, and 100 feet of rope ($\frac{1}{2}$ or 1 inch diameter), are useful but not essential.

d. It is often necessary to open jammed doors, move cars from hazardous positions or right overturned vehicles. A pinchbar, heavy scissors-type jack, ax, and stout rope (towchain or cable) about 25 feet long, are necessary for this task. A small shovel and broom are desirable to aid in clearing the road.

e. Special items are needed to aid observation, record observations, and to recover and protect evidence. A cloth tape (preferably 100 feet long, yellow lumber crayon, road paint, large nails, wood stake, clipboard, notebook, writing materials, supply of field forms, and assorted clean sacks made of paper or cellophane should be available. A camera is also essential but often photographic service is provided by a central photographic unit on the installation. The camera should preferably be a 4 by 5 press-type, equipped with flash, lens shade, tripod, and extra film holders. A drawing board and essential instruments (straight-edge, scale, suitable pencils, drawing paper, and compass) are highly desirable.

f. All equipment should be stored in locally constructed field cases, to provide for portability, protection of the equipment, and ease of checking or inspection. If items are normally kept in the accident investigation team vehicle, there may be built-in storage space for the various items of equipment.

82. Accident Investigation

This paragraph describes essential procedures to be employed by the military police-

man assigned to accident investigation duties. Military policemen should not perform them in a "by-the-numbers" sequence, but should accomplish each action in accordance with the situation.

a. Proceed to the scene quickly but safely. Prompt arrival is essential so that injured persons may be given first aid, other traffic accidents or serious traffic congestion are prevented, and facts of the traffic accident and statements of witnesses may be obtained. The military policeman must go to the scene quickly, yet safely. If time and communications permit, he should obtain from the desk sergeant available information to help him plan his activity on arrival—exactly where the accident is (if known), how severe it is, when it happened, and the possibility of hit-and-run (fleeing the scene). While en route he should be particularly watchful for suspicious or damaged vehicles fleeing the general area of the accident. The military police vehicle should be parked at the scene of the traffic accident in such a way that it will not constitute a traffic hazard; when necessary it may be stationed as a road block. At night it should be parked so that headlights illuminate the entire scene if other light is not available. Lighting helps the military police in the care of the injured, in preparing reports, and serves as a warning to approaching vehicles. During day or night the emergency lights should be on to warn of possible hazard to approaching traffic.

b. Care for the injured and protect property. When necessary, military police render first aid and secure medical assistance. Vehicles should be rerouted if the body of an injured person blocks traffic. Normally, injured persons will be moved only by medical personnel. Suggestions and complaints from bystanders should normally be ignored. Military police should protect property of injured persons (FM 19-5).

c. Establish traffic control in the vicinity. Traffic hazards should be reduced by posting signs, flags, or flares, or placing control personnel at the approaches to the scene of the traffic accident. Steps are taken to eliminate danger from fire, explosives, or broken power lines. If military personnel are available they may be used for traffic direction or other duties

when necessary at an accident scene. Persons not assisting, or not essential, should be kept off the road. The area should be cleared as soon as possible to permit resumption of the normal traffic flow.

d. Secure statements. Questioning to the extent possible should be conducted at the scene. Injured persons may have to be questioned at the hospital. Witnesses, drivers, passengers, and pedestrians involved in the traffic accident should be questioned individually out of hearing of the others. The provisions of Article 31, Uniform Code of Military Justice will apply in many cases. All persons who have knowledge of value to the investigation should be encouraged to make and sign written statements. Full identification, place of employment, street address, and telephone number should be shown at the beginning of each statement to insure that the individual may be located. Statements should include all facts pertinent to what the individual saw or heard in connection with the specific traffic accident. A careful check of each statement should be made against those of others to disclose discrepancies or omissions in their statements. Discrepancies should be clarified at the scene of the traffic accident if possible. Statements should, as nearly as possible, be in the exact words of the person giving the statement, since it becomes a part of the accident file. If fleeing the scene is also connected with this accident, descriptive information, as shown in the following example, should be secured by the military policeman and provided as soon as possible to the military police station for dissemination:

- (1) Make of vehicle (Chevrolet, Ford, Opel, or Mercedes).
- (2) Type (sedan, convertible coupe, or station wagon).
- (3) Colors (blue body, grey top, and red wheels).
- (4) Identification data (license plate numbers and letters; installation registration numbers and letters on decals or plates; and bumper or body markings).
- (5) Outstanding features (blue flag on aerial, luggage on top).
- (6) Accident markings (right front headlight believed broken, will probably

show collision marks on entire right side, may show brown paint from victim automobile).

- (7) Operator and passengers (operated by man in Army uniform; woman passenger wearing dark glasses and bright colored scarf).
- (8) Location and time. (Accident occurred at intersection of 4th Avenue and 38th Street at 1040 hours. Hit-and-run vehicle last seen traveling at high rate of speed on 4th Avenue in direction of Gate No. 5.)

e. Secure traffic accident facts.

- (1) In addition to obtaining all possible information from people, it is equally important to make and carefully record observations from physical conditions at the scene. Only at this time can the military policeman see all physical items and conditions in their true relationships. They are often the best evidence of what happened, and many facts that might go unnoted by casual observation may be brought to light by a good system of checking. Often from these physical items the military policeman finds facts which lead to further information. The military policeman should systematically examine the scene, to be sure he has covered all points or places likely to yield information or evidence, and to help him connect both information and evidence to some aspect of the accident.

- (a) Checking should start in the area where the vehicle came to final rest. Debris or broken parts from vehicles, together with other indications will help locate the key event at a specific point and will indicate the path of vehicles involved. Forward motion of the vehicle and the force of impact, or the action of traffic, will often scatter debris over a considerable area. The debris may yield evidence leading to the identity of a hit-and-run vehicle. There will often be marks or traces such as skid or scrape marks, which will help the investigator locate the

pertinent points accurately. All marks, oil or water puddles, bits of metal, and contents of vehicles scattered over the scene need to be carefully examined, and their positions measured and recorded. Skidmarks are important; they show not only the position and direction of travel, but often reveal evasive action or unlawful behavior of units involved. The military policeman should know how to identify, measure and record skidmarks. The point of impact itself must be carefully measured and located with respect to curb lines, centerlines, and recognizable permanent objects.

- (b) From the point of final rest the military policeman should trace the path or route of each vehicle, looking particularly for further marks or evidence, and all information which helps in determining the actions of the driver or pedestrian and assists the military policeman in completing his investigation. The roadside as well as the roadway should be examined. Visibility, condition of signs and signals, condition of the road surface, volume of traffic, angles of view, and possible distractions should be considered. The circumstances of each accident will determine how far back along the approach the investigator should check; if high speeds are involved, this search may extend several hundred yards. The roadside and surrounding area must not be overlooked, even if the vehicles did not leave the roadway. Every item or mark which could have a bearing on the accident should be examined carefully and treated as evidence until its status is clearly determined.
 - (2) The vehicle, its equipment and its contents require careful inspection. Every item having to do with its control, such as tires, brakes, lights, steering, and signals, and all other safety equipment should be inspected for condition. This may require later

checking or verification by a qualified mechanic. It is important, for example, to know whether a tire blew out as a result of the accident or whether the blowout was a possible cause of the accident. Contents of the vehicle may give important leads to the identity, residence, occupation, or destination of drivers or occupants. The nature, extent, and location of damage to vehicles, and the kind, location, and extent of injuries to victims, must be carefully checked and recorded.

(3) Recording and retaining data are essential. The military policeman can help to make recorded data more effective by understanding and using a few well-established principles.

(a) *Use of forms.* Forms are only devices intended to provide space for recording certain essential information in a uniform way, for the use of statisticians, provost marshals, safety directors, and others who need the information. In addition to the items printed on the forms, some kind of supplementary reporting is often needed to include information for which adequate space is not provided. Additional drawings, statements, reports of conditions, followup investigations, photographs and other exhibits, are some of the items not always provided for on forms. Military police will adhere to the provisions of AR 190-15 in filling out DA Form 19-68 (Military Police Traffic Accident Investigation).

(b) *Measurements and sketches.*

1. To record measurements, first prepare a free-hand sketch of the scene to approximate scale, and mark on it by appropriate symbols the items to be shown. Each measurement, as taken, should be recorded on the sketch. Standard symbols should be used, for example the best way to indicate twelve feet six inches is to write —12⁶—, rather than

12½ or 12'6". Every distance must be accurately measured.

2. Sketches serve four purposes: to help explain the accident; to enable the military policeman to recall facts, when required; to locate again any given point at the scene; and to serve as a basis for accurate scale drawings when needed. Field sketches should be preserved even though they have subsequently been reproduced in a report or a scale drawing has been made; such sketches are part of the military policeman's original notes.

(c) *Photography.*

1. Photographs often describe things better than words; they record facts sometimes overlooked at the scene; they help recall details and they often prove some important point. However, because the military policeman obviously cannot photograph everything in every accident, he must be discriminating. He should have a purpose in mind for each picture he takes, rather than make photographs just for undefined "record purposes."

2. Pictures should supplement the investigation and reporting of an accident, but never take the place of investigation or reporting. To report facts honestly, pictures should be as nearly as possible true representations of what is photographed; their scale, angles of view, and color or light values should be approximately as seen by the normal eye, with a minimum of distortion. If they serve some special purpose, however, and if adequately described in the report, special photographs (for example, one taken from a high viewpoint, looking down at the scene) may be used. Good photographic quality is obviously preferred over pictures which are poorly focused, improperly exposed or incompetently processed.

3. If pictures are worth taking, their evidence value is worth preserving. The chain of custody should be established and recorded. Who took the picture? Who processed it? What camera, film and exposure were used? What is the subject of the picture? When and where was it taken? What other pictures were taken? These are some of the questions which often arise when photographs are presented in court. Photographs should not be retouched, and no part of a negative should be enlarged and presented as a whole picture, except for a specific purpose. When so presented, such pictures should always be accompanied by prints of the whole negative. All negatives, even those of doubtful value, should be identified and retained. See Appendix V, Guide for Photographing a Traffic Accident.

- (d) *Complete and accurate note taking.* The military policeman should make notes of all significant facts or developments in the accident. He must report all action he took which may affect the outcome or disposition of the investigation, even though not contributing to the understanding of the accident. In this connection he must note particularly what part of the report is incomplete, and any guide to the successful followup of the investigation. Accuracy is essential in names, addresses, serial numbers, registration numbers; these and similar data should be obtained from official papers or records whenever possible. Notes should be preserved as long as reasonably needed to assure that all criminal or civil action, in which the military police might be called to testify, has been completed.
- (e) *Objective reporting.* The report should clearly distinguish between items of fact and those of opinion. Opinions should be clearly identi-

fied as such. Opinions are important and the military policeman should summarize in writing his opinion of what happened, how it happened, and what were the direct, mediate and early causes.

f. Check on operator's vehicle accident report. The operators of military vehicles should be reminded by investigating military police to complete Standard Form 91 (Operator's Report of Motor Vehicle Accident) and DD Form 518 (Accident Identification Card), if a government vehicle is involved in an accident. The operator of the government vehicle should fill out DD Form 518 (Accident—Identification Card) and give it to the operator of the other vehicle or the pedestrian involved. If the operator of the government vehicle is not capable of completing the DD Form 518, the military policeman will complete it.

g. Clear the traffic accident scene and complete the report.

- (1) Military units normally remove their own vehicles but if this is not practical, the military police arrange for the removal. Civilian vehicles are normally removed at the owner's expense. Until this action is taken guards or flares are posted to prevent additional traffic accidents. Roads are cleared of debris. Apprehension of military personnel is made when necessary, or violation reports are prepared.
- (2) Traffic accident reports must provide accurate information. There will be very few instances when traffic accident reports can actually be completed at the scene. In most cases there are medical certificates or statements to be obtained at a later time. As a result, the report cannot be completed immediately, but it should be prepared so far as possible at the scene. DA Form 19-68 (Military Police Traffic Accident Investigation) should be used to record information obtained. It should also be used for submitting the final report on an accident. Instructions for preparations of the

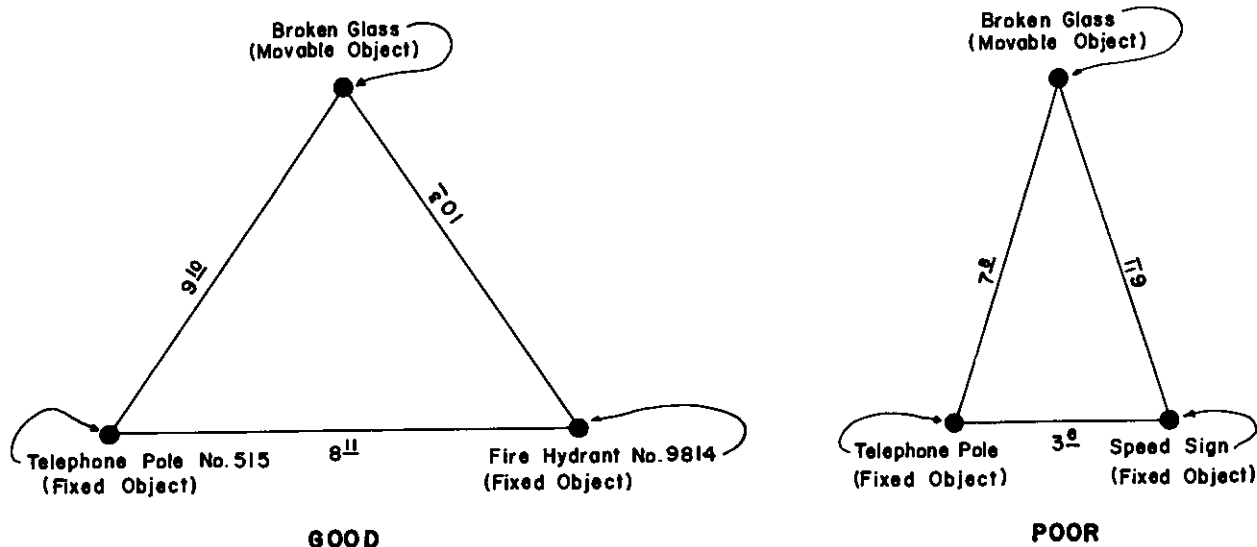


Figure 31. Example of triangles apex angle.

DA Form 19-68 are printed on the reverse of the form.

h. Recheck the report. During this step, the military policeman should completely rewrite the report and draw to scale, if appropriate, an accurate diagram of the traffic accident scene. He should check and recheck the information recorded on the traffic accident report to insure that there are no omissions. Some of the questions he should ask himself are:

- (1) Does the diagram of the traffic accident give a clear view of what happened? Does it include street dimensions?
- (2) Is the presence or absence of obstructions noted?
- (3) Are the locations and descriptions of traffic signs and control devices complete?
- (4) Have statements been taken from all witnesses and has all necessary personal data been obtained?
- (5) Has a doctor's or medical officer's diagnosis of all injuries been obtained so as to assist in justifying or refuting claims for physical injuries?

83. Special Considerations

a. Triangulation. Triangulation is a method of accurately locating a place on the ground. Triangulation is merely establishing the loca-

tion of a movable object by measuring its distance from two other easily identifiable fixed objects. Fixed points from which measurements are made should be as near as possible at 90° angles with the object of interest to be placed on the sketch and should be at a sufficient distance from each other to form, as far as possible, an equilateral triangle. Narrow triangles are not considered as good as wide or equilateral triangles because the possibility of error is greater when the apex angle is too narrow (fig. 31).

b. Diagram Identification. The diagram should be marked and fully identified. Failure to do this can result in the diagram becoming useless if once separated from the traffic accident report. The following information should be placed on the diagram:

- (1) Date and hour of the traffic accident.
- (2) Names of the roads or streets. If the accident occurred on a rural highway the distance to the nearest easily identifiable landmark should be shown.
- (3) Direction of North.
- (4) Names of the military policemen who took the measurements and made the drawings.
- (5) The traffic accident report or case number.

c. Skidmarks.

- (1) Skidmarks appear on the road surface when the brakes are applied and

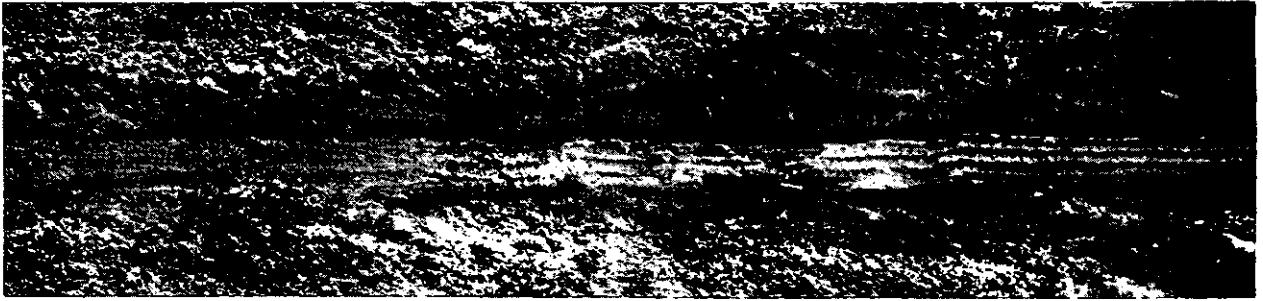


Figure 32. Examples of skidmarks in dirt. A—Rolling wheel; B—wheel is stopped; C—wheel with brake locked. (Note the lack of tire marks in the soil at point C.)



Figure 32—Continued.

the wheels cease to rotate while the vehicle is still moving. To reach a

valid conclusion as to vehicle speed, it is important that the military policeman be able to determine the difference between skidmarks and other marks made by tires.

- (2) Characteristics of skidmarks are:
 - (a) There will be no cross patterns appearing on a skidmark.
 - (b) A skidmark will also have an absence of signs of steering.
 - (c) The tire in a skid will not splatter substance on the roadway as a rolling tire will.
 - (d) The skid will not leave material outlining the tread of the tire (fig. 32).
- (3) Prior to making skidmark measurements, mark the end of the skidmark, the beginning of the dark skidmark and the beginning of the light shading skidmark, which is termed a shadow (fig. 33). To be valid, all tires must have made skidmarks. Each of the marks must be measured in two ways.
 - (a) Measure the length of the dark skid.
 - (b) Measure from the beginning of the shadow to the end of the skid.
 - (c) Include in the measurement any skips. (A skip is an area along a skid that has no marks. It usually does not exceed 3 feet in length and is caused by a locked wheel losing contact with the pavement. This loss of contact could occur when a vehicle's wheel passes over such things as a rut, bump, or railroad grade.) To insure accuracy, the location of skips should be shown on any

SKIP



GAP



Figure 33. Skidmarks showing a gap and a skip. A—The shadow or light beginning of a skidmark; B—the skid between the skidmarks. Note the lack of a shadow or light skidmark after a skip. The distance of a skip is usually not more than 3 feet. C—The gap is an area where the brakes are not locked. The skidmark after a gap is a new skidmark starting with a shadow and light skidmark. The gap is usually in excess of 10 feet.

sketches and separate measurements of the skip recorded.

- (d) Do not include in the measurement any gaps. (A gap occurs when the brakes are released and the vehicle's wheels are turning. A gap is usually observed as a space in excess of 10 feet in length on the ground between skidmarks.)
- (4) If the skidmark is on two different types of pavement it must be measured separately on each type of pavement. The percentage of incline or decline must also be estimated (road gradient, see app. VI) and recorded. A valid measurement must be made within a 6-inch tolerance. The most accurate evaluation of a skidmark is by a test skid of the vehicle involved. The military policeman should call for technical assistance when it appears that a test skid is necessary.
- (5) To insure that the positions of skidmarks can be rechecked at a later time the beginning and end of each

mark may be marked. Nails may be driven into asphalt, paint may be used on concrete and stakes may be driven into a dirt surface.

d. Other Road Marks.

- (1) Scuffmarks are valuable in tracing the vehicle path but cannot be used to determine speed. They should be marked and measured in the same way as skidmarks. Scuffmarks are marks left by the tire while the wheel is still turning. They are classified as—
 - (a) Decelerating scuffs—found at beginning of skids.
 - (b) Accelerating scuffs—left by wheels spinning on the roadway.
 - (c) Side scuffs—left by vehicle going around curve.
 - (d) Combination scuffs—any of the above in combination.
 - (e) Flat-tire scuffs—rubber residue left on pavement by the edges of an overheated flat tire.
- (2) Scratches and gouges are left on the pavement by metal parts of the ve-

hicle in contact with the roadway. These must be located, measured, and photographed. Any foreign material left in scratches and gouges should be collected and protected like all other evidence. It is very important that evidence is collected prior to moving the vehicles involved in the accident, since movement of the vehicles may add damage to the roadway.

84. Followup Activities

The investigation is not always completed at the scene, nor is it always completed when causes have been determined and findings reported. Often a number of things are needed to complete the information or action. Some of the more important of these are:

a. Fleeing the Scene Accidents. The accident investigator must keep in mind that when a fleeing the scene accident (hit-and-run) occurs he is really dealing with two separate events. One of these is the accident, which must be investigated and its causes determined as in any other accident. The other is the criminal offense by the operator of failing to stop to identify himself and render aid, when needed. Hit-and-run is never a cause of an accident; the offense of failing to stop and render aid occurs after the accident. Followup of such cases may go on indefinitely, because of the number of leads which must be checked. The science and techniques of criminal investigation must be used.

b. Drunken Driving. Before leaving the scene the military policeman should also check for evidence indicating that the suspect drove the car involved in the accident while drunk. The military police may be required to visit a residence, tavern, or club to check for this information. The decision to request a medical examination of a driver suspected of drinking is normally made by the provost marshal or the military police duty officer. The time consumed in obtaining this decision should be kept to a minimum. If it requires that the military policeman leave the scene, he should not do so until all emergency matters have been cared

for, and he has obtained basic essential information about the accident.

c. Accident Victims. Checking on the condition of accident victims at medical facilities or their residences is frequently required. Where long hospitalization or recuperation is expected, the military policeman should arrange with the hospital or physician to notify the provost marshal's office when the injured person can be interviewed or when he can leave the hospital.

d. Examination of Facts. Even an experienced military policeman may overlook some essential fact which could have been noted during his original investigation. Some important witness may have been overlooked, some new witness may be found, some circumstance or condition may come to light, or there may be some error or discrepancy which requires re-examination. Sometimes measurements are in error or not enough measurements were taken to make a scale drawing. Sometimes additional photographs are required. Investigation or followup is often needed, particularly in complicated cases. The longer the delay, the greater difficulty will the military policeman have in getting the needed information.

e. Reporting Violations. The reporting of violations committed by those involved in accidents is one of the purposes of reporting accidents. Traffic law enforcement is justified and necessary because of its deterrent and accident-prevention values, and even more so when specific unlawful behavior or condition contributes to a traffic accident. However, it is not necessary that the violation did in fact contribute to the accident. For example, the failure of a driver to have a license may not have contributed in any way to the accident; nevertheless, he should be cited for this violation. The report should list all violations committed by all personnel involved in an accident. Inasmuch as an accident may be a complex series of events and the action of one driver may have directly contributed to the accident, a thorough check must be made to insure that the others did not also violate the law. *Every effort should be made to discourage the belief among road users that accidents are caused by "the other driver."*

CHAPTER 7

GENERAL CONTROL OPERATIONS

Section I. PARKING

85. Permanent Parking

Permanent parking facilities are developed as an integral part of the whole traffic and building plan of the installation. Military police gather and supply information so that the plan will rest on a firm basis. The military policeman must constantly be alert for and report problems that arise with regard to parking. Some characteristics of a parking problem are:

- a. Excessive, illegal, and overtime parking.
- b. Excessive cruising to find parking spaces.
- c. Extensive congestion in the traffic flow caused by cars attempting to park.
- d. Parking in excess of 400 feet from the destination of the occupants of the vehicle.

86. Temporary Parking

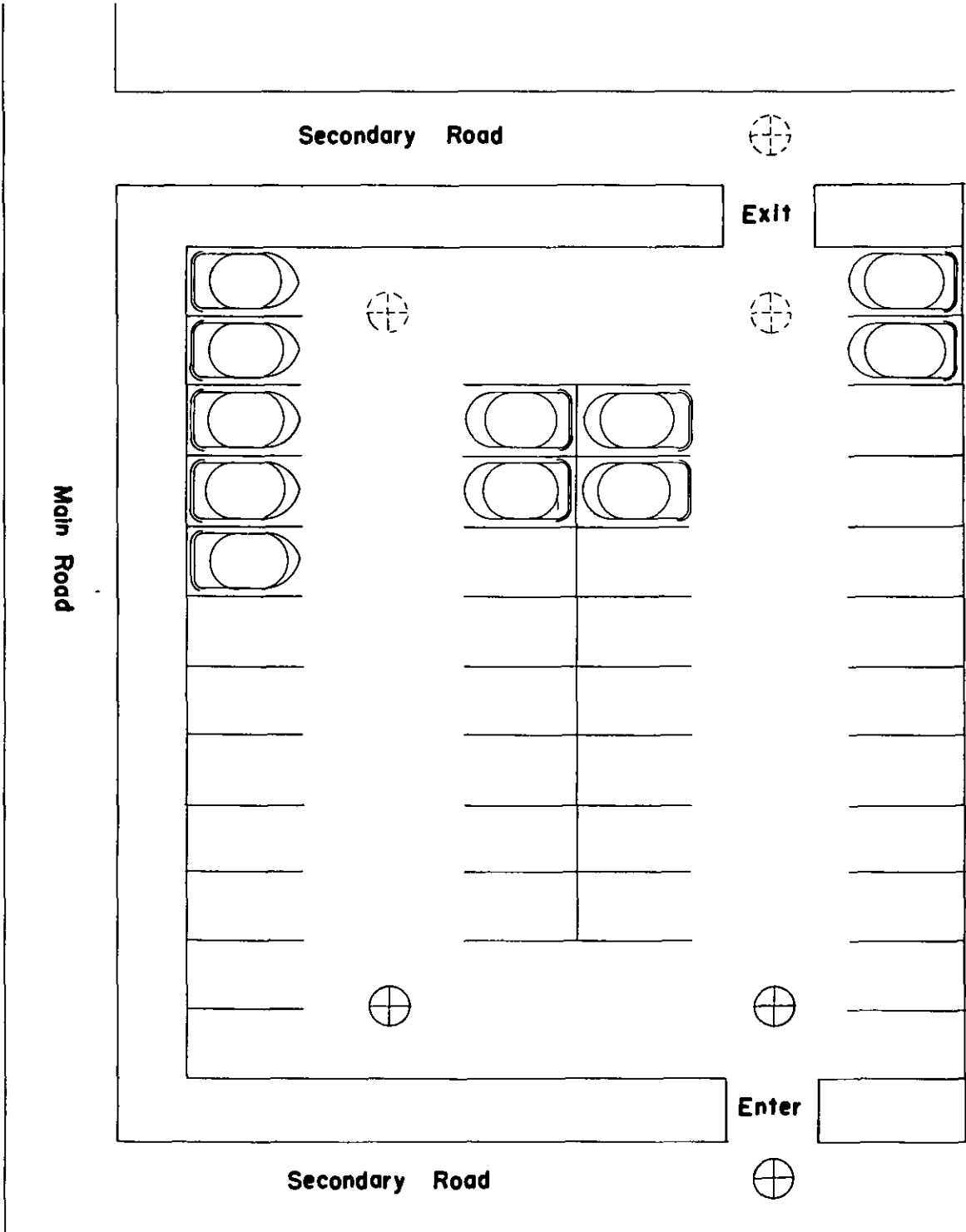
Military police normally will be required to establish only temporary parking facilities for a temporary period or at a special event.

a. Prior to establishing a temporary parking area, the military police will conduct a survey of the area to be used. During this survey all areas that are not to be used, because of the presence of ruts, rocks, trees, or other obstruction, should be marked off. If time permits a diagram of the area should be made. All parking lots should have a number of clearly defined entrances and exits. In planning entrances and exits every effort must be made to insure that, if possible, traffic enters and exits on secondary roads. When it becomes necessary to use a primary road, additional control is necessary to reduce congestion and prevent accidents. When considering movement into and through a parking lot, every attempt should be made to segregate pedestrian and vehicle traffic.

b. When it is anticipated that vehicles using the temporary facility will enter and exit in a relatively short period of time, the parking plan should provide for use of 90° parking stalls. The outside row of vehicles should be

a single row of vehicles backed in. Parking this row of vehicles will consume the most time and should be filled by directing only a limited amount of traffic to this area. Other vehicles should be placed in double rows. The recommended minimum stall width is 8.5 ft; length is 20 ft. To provide for emergencies and allow for early departures, an aisle of 23 feet is provided between the double row of vehicles (fig. 34). If it is anticipated that a large number of small cars will use the parking facility, it is desirable to designate an area for these, thereby achieving maximum utilization of space. In filling the area every effort is made to insure it is accomplished without congestion. During the period when the parking area is to be emptied every effort must be made to provide for equal flow from each parking aisle. In allotting moving time the change of flow should be done during breaks in the stream of traffic or when all traffic has stopped. This will reduce the time that is lost during the safety period allocated for a change of direction.

c. When the requirement for parking is to provide space under conditions of constant vehicle turnover, such as during an exhibit, the parking plan should provide for use of 60° parking stalls, 9 feet wide. This angle provides ease in entering and leaving the parking stall. The aisles will provide for one-way traffic and should be a minimum of 18 feet wide (fig. 35). Controls must be maintained to insure that drivers do not cruise to find parking space. If there is a shortage of military policemen for this duty, the one-way flow on aisles and the direction of angle should be alternating (fig. 36). The roadway on both ends of the parking area must have a minimum width of 24 feet to accommodate two-way traffic. Signs should be erected to reduce confusion and congestion. Tapes or lines may be used to mark stalls to provide better parking.



LEGEND



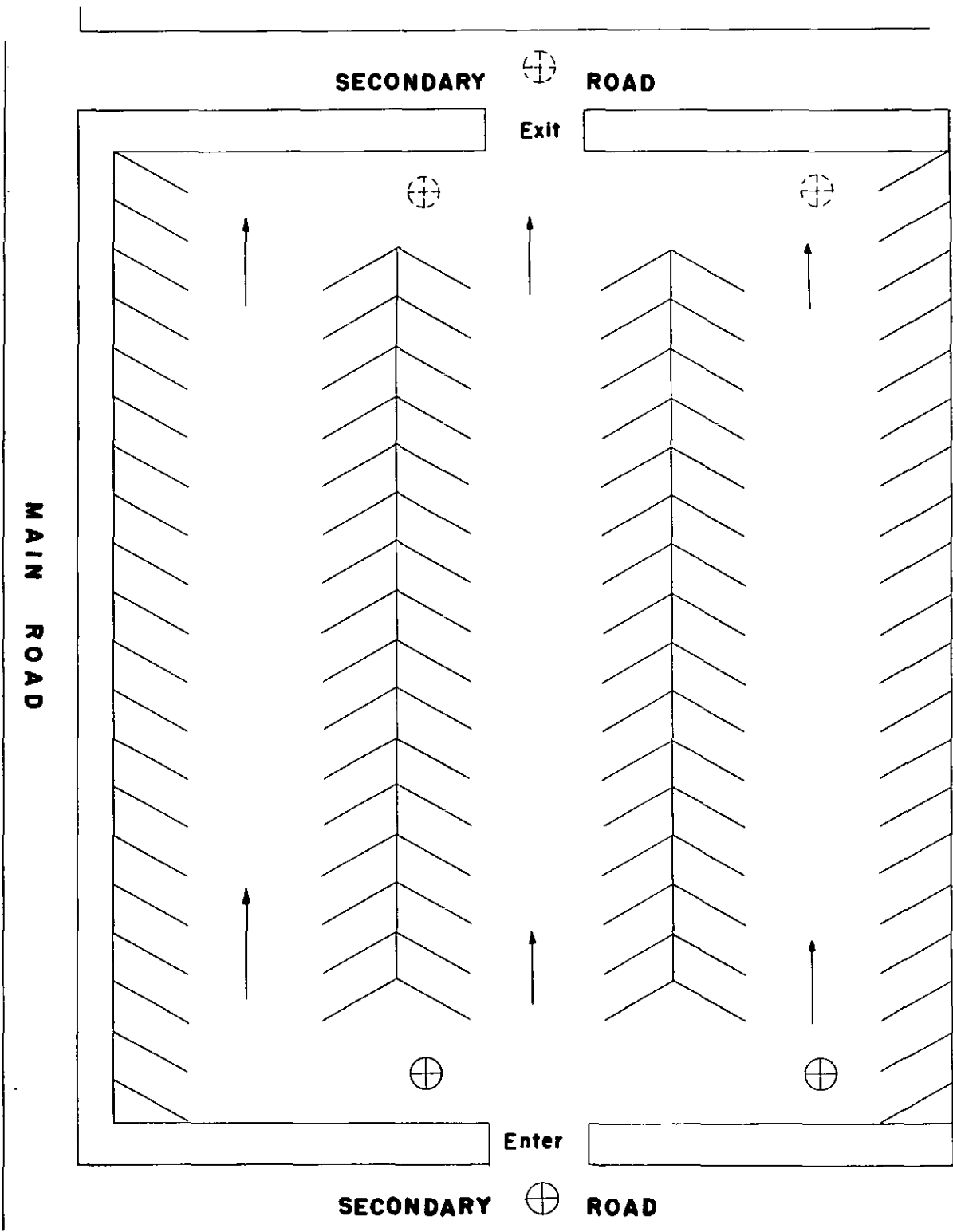
-  Military Policeman Entering Movement
-  Military Policeman Exiting Movement

Figure 34. Example of a temporary parking facility with no turnover.
(See figure 6 for dimensions.)



LEGEND



MP Entering Movement



MP Exiting Movement

Figure 35. Example of a temporary parking facility with turnover.
 (See figure 6 for dimensions.)

**LOCATION
OF SIGNS**

- ① 
- ② 
- ③ 
- ④ 
- ⑤ 
- ⑥ 

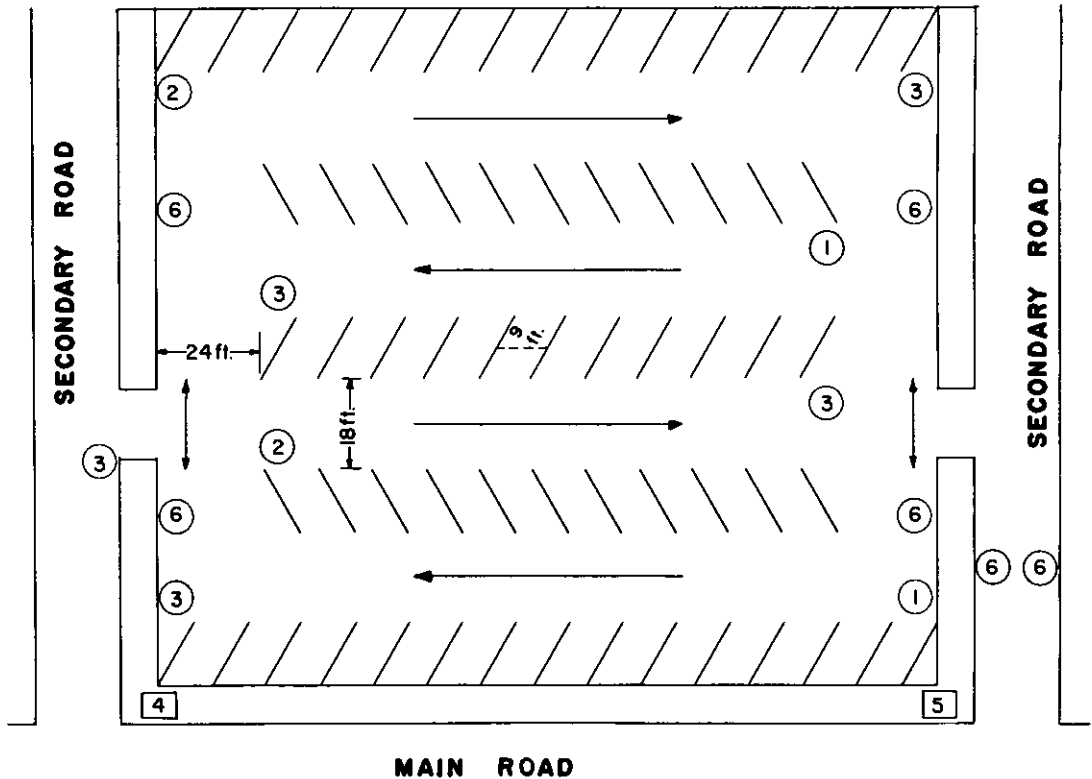


Figure 36. Example of a temporary parking facility with a turnover using alternating one-way aisles.

Section II. ESCORTS

87. General

Military police perform escort duty in order to provide security, to prevent congestion, or to expedite movement of a traffic unit consistent with speed laws and safety. Safety is not to be sacrificed for speed during the normal escort, and consideration must be given to the other road users and the obedience of traffic laws.

88. Methods of Escorts

a. Leading and Following. *Leading and following* is the use of military police patrols to lead and follow the vehicle(s) escorted. The *leading* patrol assists in securing the right-of-way. Lights and sirens may be used as prescribed by law and the local SOP. When the escort is approaching an intersection, the lead-

ing patrol may dismount and perform point control until the head of the column reaches the intersection; at that time the military policemen remount and resume their lead role. The *following* patrol keeps the end of the column closed up, renders assistance, and provides any necessary security.

b. Leading. Only one vehicle is used in this method, as a lead vehicle for those escorted. This is not the most desirable method; however, it is the most commonly used since the military police patrol called upon for emergency escort will normally be limited to one vehicle. The escorting vehicle secures clearance through intersections and traffic congestion.

c. Empty Truck. This is a technique used for posting traffic control personnel ahead of the movement they are escorting. Traffic control

personnel who are to perform point control at key intersections and other points of difficulty are mounted in a truck, which departs prior to the movement, and are posted along the route of the escort. An empty vehicle follows the movement and picks up these traffic control personnel. Control personnel should be numbered so that none will be missed by the pickup vehicle. This technique is normally used in addition to the one described in *a* above, with the empty truck taking the place of the following vehicle. If temporary signs are used to guide the movement, it is normally the duty of personnel in the empty truck to retrieve them after the movement has passed.

d. Leapfrog. Leapfrog is a technique employed by escort patrols, who move ahead of the movement and assume traffic control posts at intersections and other points where delay or congestion may occur. As soon as the movement passes their posts, the escort personnel remount, overtake and pass the movement, and assume successive posts along the route of escort. Personnel may be assigned to specific posts according to a prearranged plan. This technique has definite limitations on narrow or heavily traveled roads because escort patrols may have difficulty in passing the movement due to heavy opposing traffic, hills, curves, and other such conditions.

e. Modified Leapfrog. The modified leapfrog escort normally involves two patrol vehicles. The patrols move ahead of the movement and post themselves at successive locations where control is needed. As soon as the escorted vehicles, moving at close interval, enter the intersection and traffic from other directions is stopped, the patrol remounts its vehicle, passes the movement, and proceeds to the next point where control is needed. This procedure is repeated by each patrol until the movement reaches its destination.

f. Aircraft. The use of rotary-wing and fixed-wing aircraft aids in effective escort of a large convoy. Their use is of particular value for escorting traffic over rough terrain. They are best utilized when employed with ground escort on the same communication net. The military policemen on the ground respond to situations reported from the air. Rotary-wing aircraft

may also be used to place military police on traffic control posts, and to relieve them or move them ahead to other posts, using an air version of the empty truck or leapfrog methods.

g. Perimeter. This technique employs escorts on all four sides of the escorted vehicles. While the perimeter escort may consist of a vehicle in front, a vehicle following and one vehicle on each side as a minimum, it can be expanded with the addition of more perimeter rings (fig. 37). The combination of this system with aircraft is a further refinement.

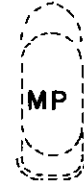
89. Employment of Escorts

a. Convoy Escort. One of the most common escort duties the military policeman will perform is the escorting of convoys. The leapfrog or modified leapfrog is the technique most commonly used for this type of escort. The convoy commander is responsible for his movement and the military police provide assistance. The military police will not dictate procedures to the convoy commander; however, they may be required to relay information concerning scheduling, routing, and local laws to the convoy commander. The basic goal of the military police under these circumstances is to provide a safe and law-abiding move for the convoy.

b. Escort of a VIP. This type of escort may vary from a simple leading vehicle escort through traffic, to a maximum perimeter escort for VIP. If called upon to assist in providing an escort for a civilian dignitary, the military police will be integrated into a detailed plan. The leading vehicle escort will be most commonly used for VIP escorts to provide direction. Under usual conditions a local military police SOP will prescribe procedures to be followed. The escorting of a VIP does not give the military policeman the authority or right to violate the law. The military policeman must judge his speed by the speed of the VIP vehicle. He must insure that the VIP vehicle does not become separated from the escort vehicle and that all direction changes can be made with smoothness and safety. The use of warning lights and sirens will be prescribed by local SOP.

c. Security Escort.

- (1) One type of security escort would include finance or prisoner movements. The goal of this escort is to provide



LEGEND



Minimum Perimeter Escort



Proposed position of additional escort vehicles for perimeter escort

EV Escort Vehicle

Figure 37. Example of a perimeter escort.

security. The lead and follow escort technique is used most frequently for this duty. The escort must be close knit and must move as one unit. Vehicle drivers must be immediately responsive to all situations encountered. Other escort personnel must be assigned specific tasks such as providing cover to the flanks. If only one escort vehicle is provided it should be used as a follow vehicle. This allows

the escort to provide security to the vehicle that is being escorted.

- (2) Another security escort involves the escorting of a classified shipment. It is not unusual for this type of movement to require a perimeter security escort. Specific steps to be performed during an escort of this type will be prescribed by local SOP. The military policeman must be constantly aware of the importance of this type escort to the defense of the country.

Section III. TRAFFIC SIGNS AND SIGNALS

90. General

The erection and maintenance of signs is the responsibility of the engineer. However, the military police assist by reporting needs for signs and requirements for maintenance, and have responsibility for the erection and maintenance of temporary signs.

91. Function of Signs

The basic device for controlling, safeguarding, or expediting traffic is the traffic sign. As with any other type of traffic control, signs should be used only where necessary and where justified by facts and field studies. Signs are not ordinarily needed to confirm well-known or universally recognized rules of the road, such as that requiring drivers to keep to the right, but they are essential where special regulations apply at specific places or at specific times only, or where hazards are not self-evident. They are also needed to give information as to highway routes, directions, destinations, and points of interest.

92. Classification of Signs

Functionally, signs are classified as follows:

a. Regulatory signs give the road user notice of traffic laws or regulations that apply at a given place or on a given roadway.

b. Warning signs call attention to conditions in or adjacent to a roadway that are potentially hazardous to traffic.

c. Guide signs show route designations, destinations, directions, distances, points of interest, and other geographical information.

93. Effective Use of Signs

Regulatory and warning type signs should be used only where required; the excessive use of such signs tends to destroy their effectiveness. On the other hand, a frequent display of route markers and directional signs to keep the driver informed of his location and his course will not lessen their value.

94. Standardization of Signs

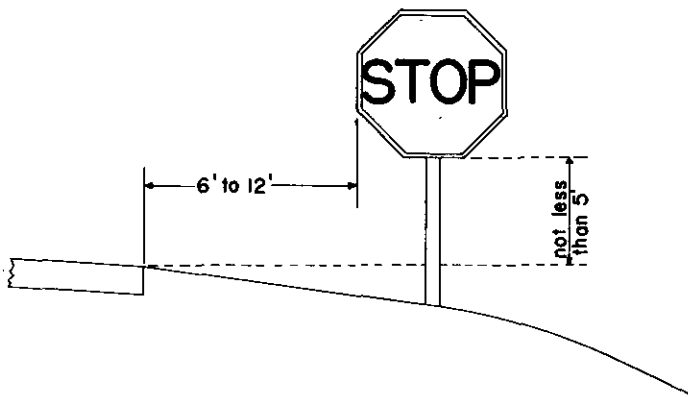
The Army achieves standardization of signs by the issuance of signs from engineer supply channels and through the use of the sign reproduction kit. When these sources are not available every effort must be made to produce signs conforming to the standards of the country in which the military police are located. In the United States the guide for signs is the "Manual on Uniform Traffic Control Devices."

95. Rules for Erection of Temporary Signs

a. Signs erected along rural roads shall be mounted at a height of at least 5 feet above the level of the roadway edge, measured to the bottom of the sign. On highspeed roads (roads with speed limits in excess of 50 MPH) this height will be at least 6 feet. In business and residence districts, and in any location where parking is likely to occur or where there are other obstructions to view, the height must be at least 7 feet.

b. Roadside signs will be placed at the edge of the road shoulder with the nearest edge of the sign not less than 6 feet and not more than 12 feet from the edge of the pavement or trav-

ROADSIDE SIGN
Rural District



ROADSIDE SIGN
Business or
residence district

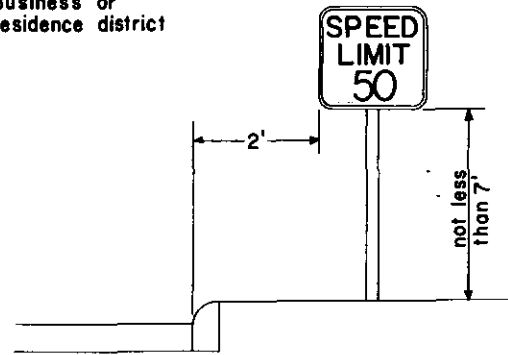


Figure 38. Examples of erection of temporary signs.

eled way, except where conditions do not permit or on highspeed roads where the nearest edge of the sign will not be closer than 2 feet to the roadside.

c. All signs will be mounted approximately at right angles to the direction of, and facing, the traffic that they are intended to serve.

d. A regulatory sign, as a rule, is placed where its mandate or prohibition applies. A stop sign, for example, is erected as near as practicable to the point where the stop is to be made.

e. A warning sign should be placed a suitable distance in advance of the condition to which it calls attention. The following rules apply as a guide to this distance:

- (1) In cities or areas where speeds are relatively low—250 feet in advance.
- (2) In rural area—750 feet in advance.
- (3) On highspeed roads and expressways—1500 feet in advance.
- (4) Where the distance is in excess of 750 feet the warning sign should be repeated before the hazard.

f. Guide signs are placed at and in advance of intersections and interchanges, and between such points of decision, in such a manner as to keep the driver well informed as to the route to his destination. The following are rules for the erection of guide signs:

- (1) Within residence and business districts advance guide signs and reas-

surance route markers should be erected not more than 500 feet on each side of an intersection. All intersections on a route within a congested area should be marked.

- (2) In rural areas advance guide signs and reassurance markers will not be closer than 300 feet to an intersection. Route marker will be used at intersection of major roads and major secondary roads.
- (3) On highspeed roads three advance guide signs will be located at evenly spaced intervals from the intersection. The first advance guide sign will be a minimum of 750 yards from the intersection. The remaining signs will be at 500 yards and 250 yards before the intersection. Guide signs will be located at all intersections. The reassurance sign should be located not closer than 200 yards or more than 500 yards past the intersection. Signs should be located on the median strip as well as the shoulders of expressways.
- (4) Except for limited access roads reassurance signs will be erected at $\frac{3}{4}$ mile intervals when there is no route sign present in an area in excess of $1\frac{1}{2}$ miles.

g. When temporary signs are intended to supersede permanent signs, whether warning, regulatory, or guide, the sign that is superseded

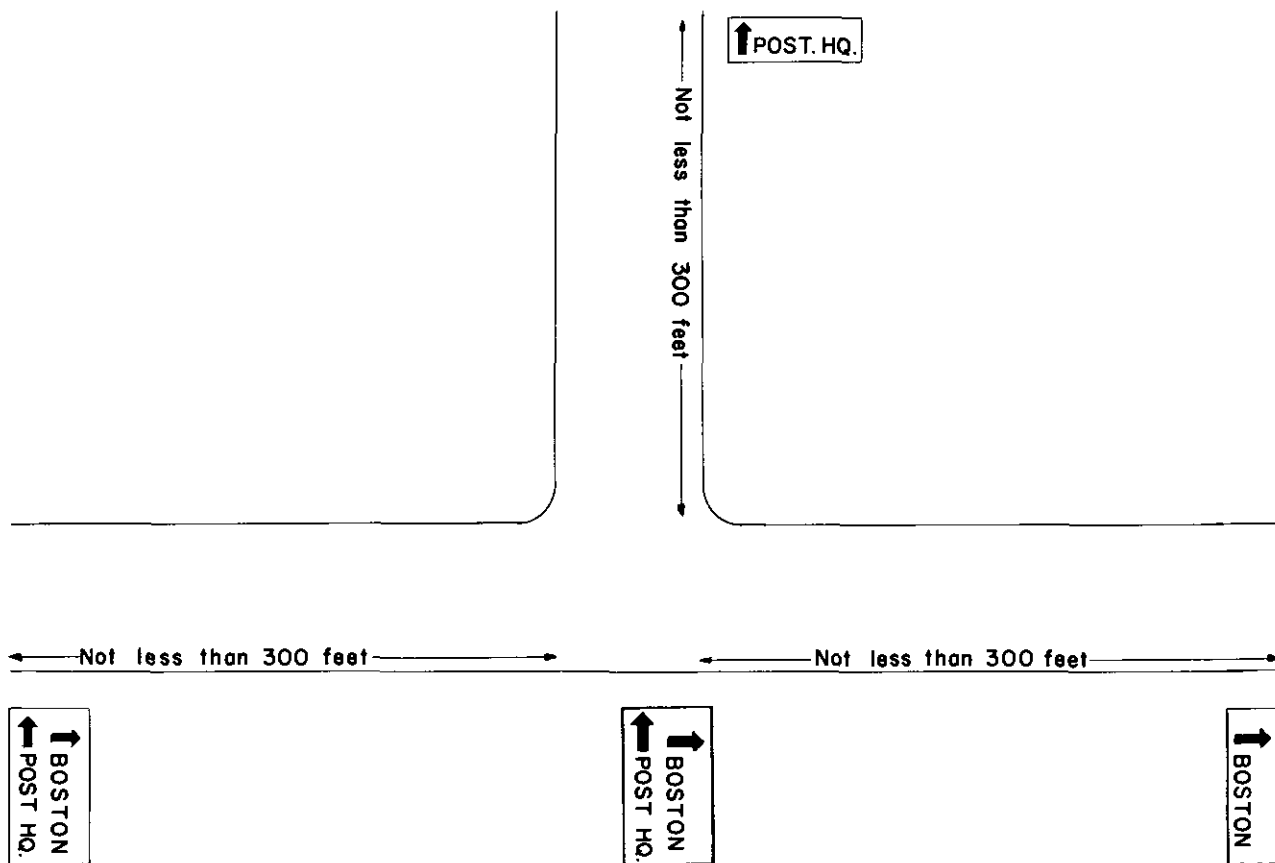


Figure 39. Example of rural area guide signs.

must not be visible to the driver. This is mandatory to prevent confusion. Permanent signs may be covered for a short period with paper and tape. When the temporary sign will control for an extended period the permanent sign should be covered with wood or cloth.

96. Variable Signs

A variable sign is one that can be changed; the most common is the maximum speed sign which provides different speeds for different conditions. Variable signs may be fluorescent or automatic and require only inspection by the military policeman, or they may be of a type which requires the military policeman to go to the location of the sign and change it manually. Specific operating rules for the variable signs will be published in local SOP. The following general rules are applicable under normal conditions.

a. Changing of regulating signs should be according to schedule. Promptness of changes

becomes critical when regulating signs involve lane use or traffic direction.

b. Warning signs such as "FOG AHEAD" or "ICE" will be used only during the period of danger. Overuse will create in the driver a tendency to disregard the warning.

c. All signs and covers will be secured to prevent the wind from exposing an improper sign.

d. When changing regulatory signs in a series, the military policeman will start at the end of the series and proceed to the starting point of the series. This prevents confusion arising among drivers.

e. Continuous checking of variable signs is necessary to insure that they are providing the proper information at the proper time.

97. Traffic Signals

a. The placement of traffic signals is accomplished only after detailed study and coordina-

tion with other signals and with the traffic flow plan. Manual operation of traffic signals must also be integrated with traffic flow plans. Those signals that can be manually operated will have detailed instruction at the control box explaining the mechanical steps necessary for manual operation. Those principles of flow adjustment presented in chapter 3 must be applied to manual operation of signal devices. Caution must be exercised in changing the signals. Once the sequence, green-amber-red, has begun, it usually cannot and should not be reversed. When normally operated, the amber or yellow time as indicated on the control drive should not be bypassed; if it is, drivers may become confused. Most traffic signals provide instructions to two or more lanes of traffic at the same time. This requires the signal operator to observe two directions of traffic at the same time. Military policemen who operate signals must have a full understanding of the traffic flow system and the phase and cycle time requirements, and be experienced in point control of traffic.

b. Under conditions that require the military policeman to perform manual point control of traffic where there is an automatic traffic signal, the signal must be turned off. A flashing signal may be used, in place of turning off the signal, on a highspeed road or during conditions of poor visibility. The color indication given to the traffic should be based on the following considerations:

- (1) The traffic traveling on a through street should be given a flashing yellow (caution) indication and the other traffic should be given a flashing red (stop) indication.
- (2) When the safe approach speed of traffic on one street differs from the safe approach speed of traffic on the other street or streets, the traffic having the higher safe approach speed should be given the flashing yellow (caution) indication and other traffic should be given a flashing red (stop) indication.
- (3) If safe approach speed and traffic volumes on both streets are not significantly different, the traffic signal may be operated as flashing red for all traffic.

c. When traffic signal becomes inoperative and it cannot be placed on flashing, the military police patrol discovering this must report this condition and normally will establish point control. Control should be maintained until the signal is repaired or it is covered; this is mandatory to prevent confusion and congestion since the road user will assume that an uncovered signal is operating and one or more of the lights are burned out. Covering of a traffic signal is ideally accomplished by cloth. However, any material that will convey to the road user that the signal is inoperative may be used.

Section IV. TRAFFIC CONTROLS FOR CONSTRUCTION OR DETOURS

98. General

a. Serious problems of traffic control occur under the special conditions encountered when traffic must be moved through or around road construction, detours, and maintenance operations. Such conditions are essentially temporary, and therefore are more dangerous and difficult to deal with because they are unexpected and not in accord with the normal pattern of highway traffic.

b. No one standard of control or control signs can be set up as an inflexible arrangement for all situations. Even for the same project, the necessary control may vary from hour to hour

and from day to day, and particularly between day and night. Simple painted signs or barricades may be sufficient by day, but at night such devices must be reflectorized and supplemented by torches, lanterns, flashers, or other illumination. On the other hand, some maintenance work is discontinued at night, leaving the highway unobstructed.

c. Maintenance activities include such minor operations as shoulder mowing, tree trimming, and ditch clearing, which may require only a little extra care in driving, or some reduction in speed due to occasional encroachments on the traveled roadway. There may be other more tangible interferences in the form of standing

or slowly-moving equipment. Pavement patching or culvert repair may close parts of the roadway for extended periods, and a major project may reduce the traveled way to a single lane, over which vehicles must move alternately in one direction at a time. In the extreme case there is a complete closing of a road, with the diversion of traffic into a temporary routing.

d. Under normal operation the responsible agency, such as the engineers or construction companies, will provide traffic control for road work projects. The military police will provide advice and assistance. The provost marshal insures that construction personnel integrate their system with the area traffic plan. Patrols operating in the vicinity of these hazards report conflicts. During period of heavy traffic or congestion the military police will assume control at these locations.

99. Signing at Construction or Detours

Temporary signs are usually placed around these hazards. The guide lines established in figure 40 to figure 44 are generally applicable but the actual signs will conform to local standards. Detour reassurance signs should be erected along the detour with a maximum of one half mile between signs and at all intersections.

100. Detour Traffic Direction

a. Whenever possible detour traffic will be routed to the right. Roads selected for this purpose should be capable of carrying all traffic.

b. When the road net is limited or bridge capacity is restrictive, trucks and passenger cars should use separate roads.

c. To assist in eliminating congestion, junctures and turns are given special attention by means of signs or point control.

d. Speed limits must be based on actual road conditions, and not set at an arbitrary figure.

e. To reduce rear-end collisions, every effort should be made to insure there is adequate space between moving vehicles. Warning may be given to drivers by signs or verbal instruction and traffic flow into the detour may be controlled to provide for proper spacing.

f. Alternating one-way operation is used when no bypass is possible. In this type of operation, a military policeman will be stationed at each end of the detour. One of the following systems can be used to change the traffic flow:

- (1) *Flags.* The military policeman at the entrance to the detour either gives a flag to the last driver in the entering group of vehicles or attaches a flag to the last vehicle of the entering series. This flag is retrieved by the military policeman at the exit of the detour. The receiving military policeman then starts a group of vehicles through the detour in the opposite direction and gives the flag to the last driver, or attaches it to the last vehicle of the group he starts. The process is repeated as required.
- (2) *Trail vehicle.* A military police vehicle enters as the last vehicle in a group that is started into the detour. When the military police vehicle emerges from the detour, the military policeman at that end starts a group of vehicles through the opposite direction. The military police vehicle again becomes the last of the entering group of vehicles. This method gives assurance that the area is clear for a return group of vehicles and provides for assistance in emergencies.
- (3) *Lead vehicle.* When the area is long and the road conditions are such that drivers may become lost, military police may use the lead vehicle technique to guide the vehicle through the detour. The lead vehicle moves back and forth guiding vehicles in each direction as required.
- (4) *Military police rider.* A military policeman mounts the last vehicle in the entering group and rides in it to the end of the detour. This technique may be used when it is essential to insure that all vehicles have cleared the area and that only military vehicles are using the road.
- (5) *Radio or telephone.* By using reliable communications between traffic con-

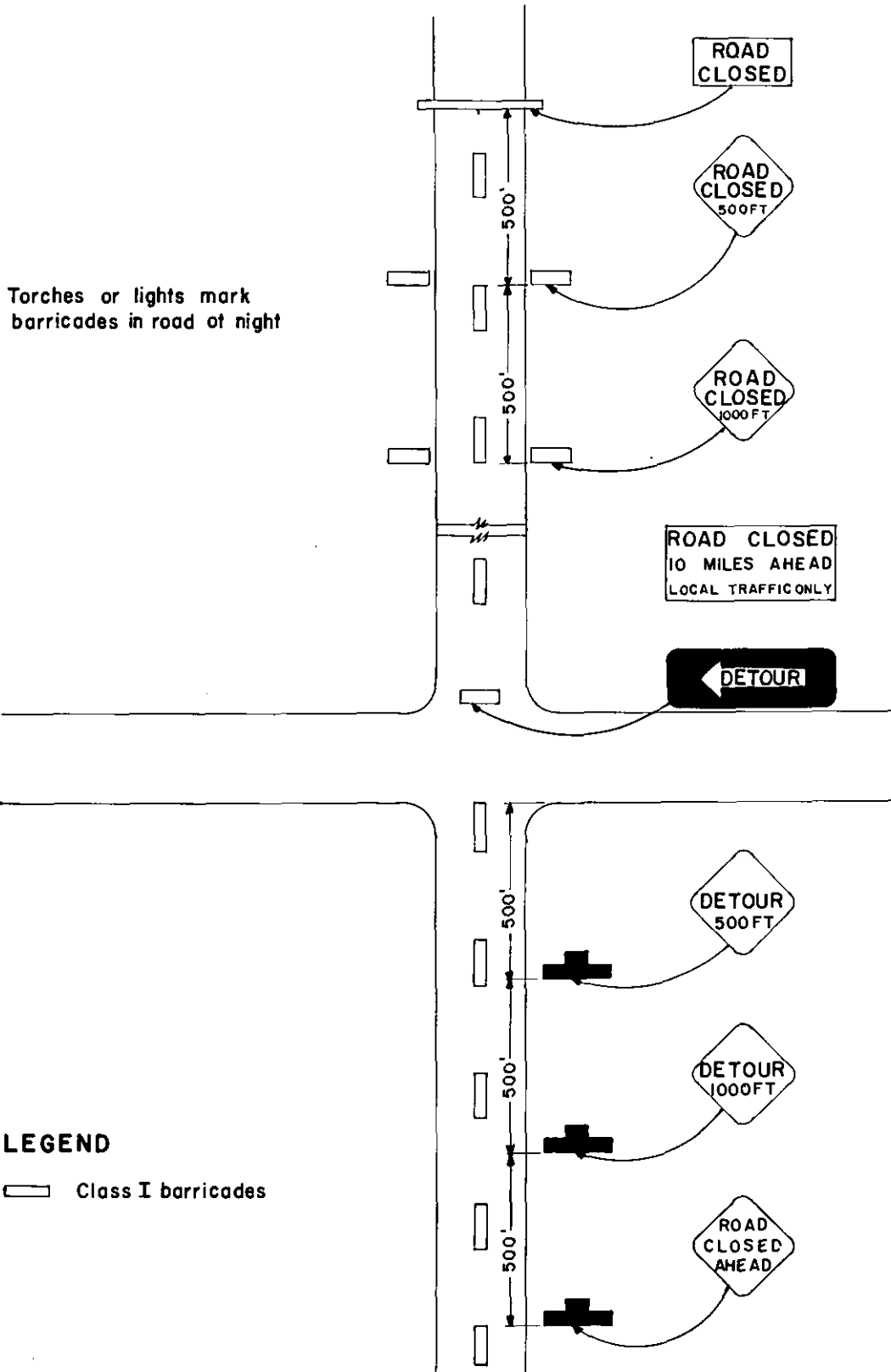




Figure 40. Example of signing for a closed road.

Warning sign sequence
in opposite direction
same as below

LEGEND

-  Flagman
-  Cone

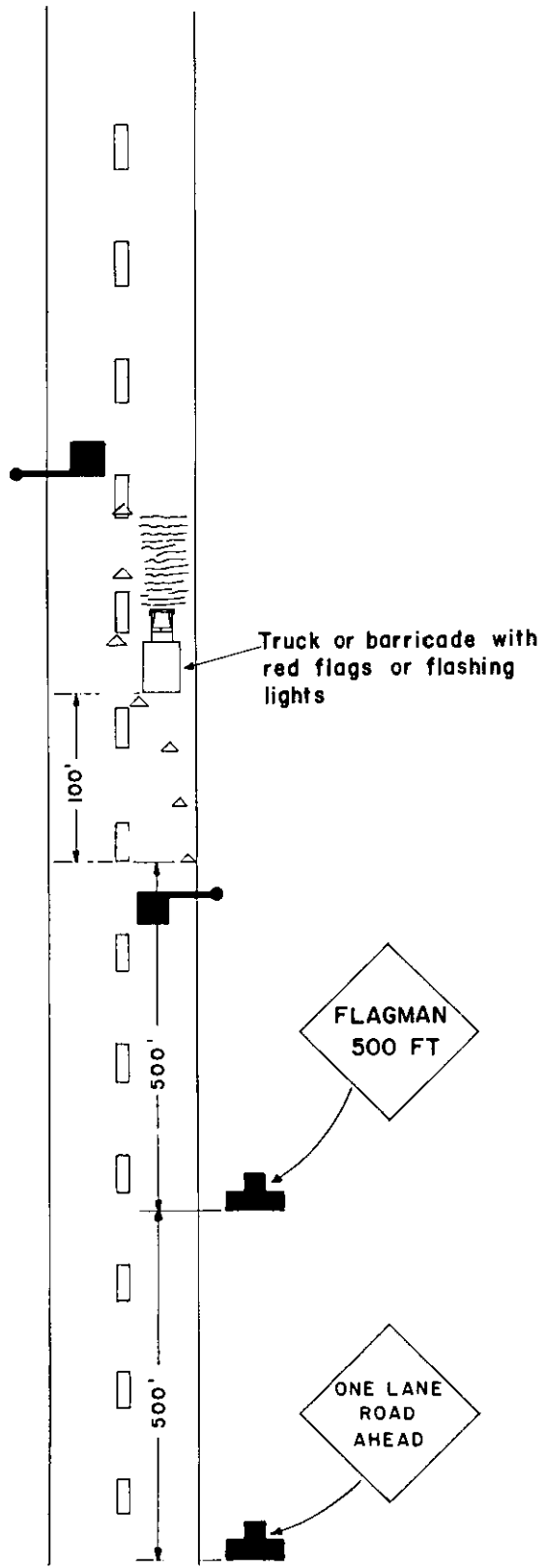


Figure 41. Example of one lane closed road using a flagman.

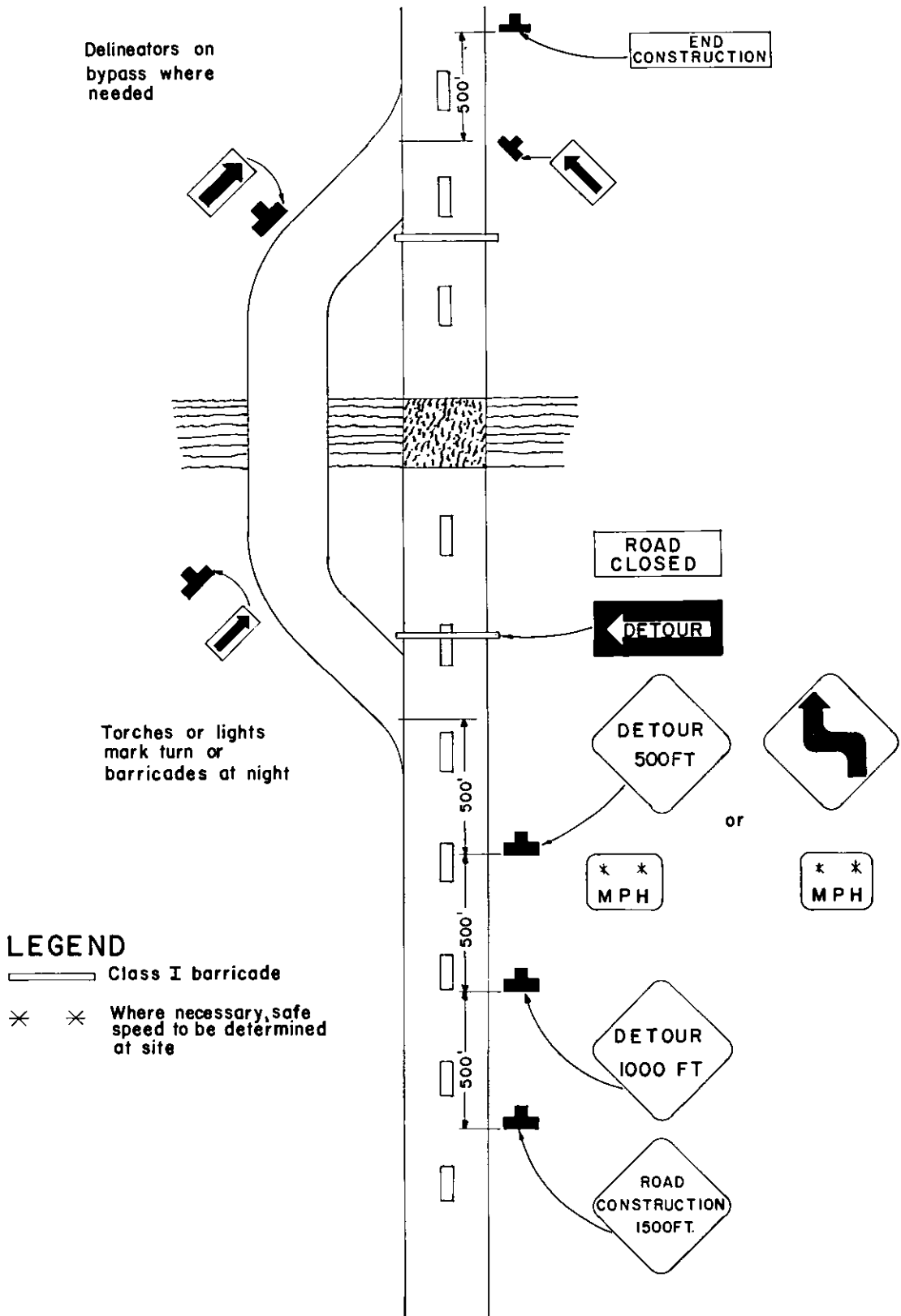


Figure 42. Example of signs used for a bypass road.

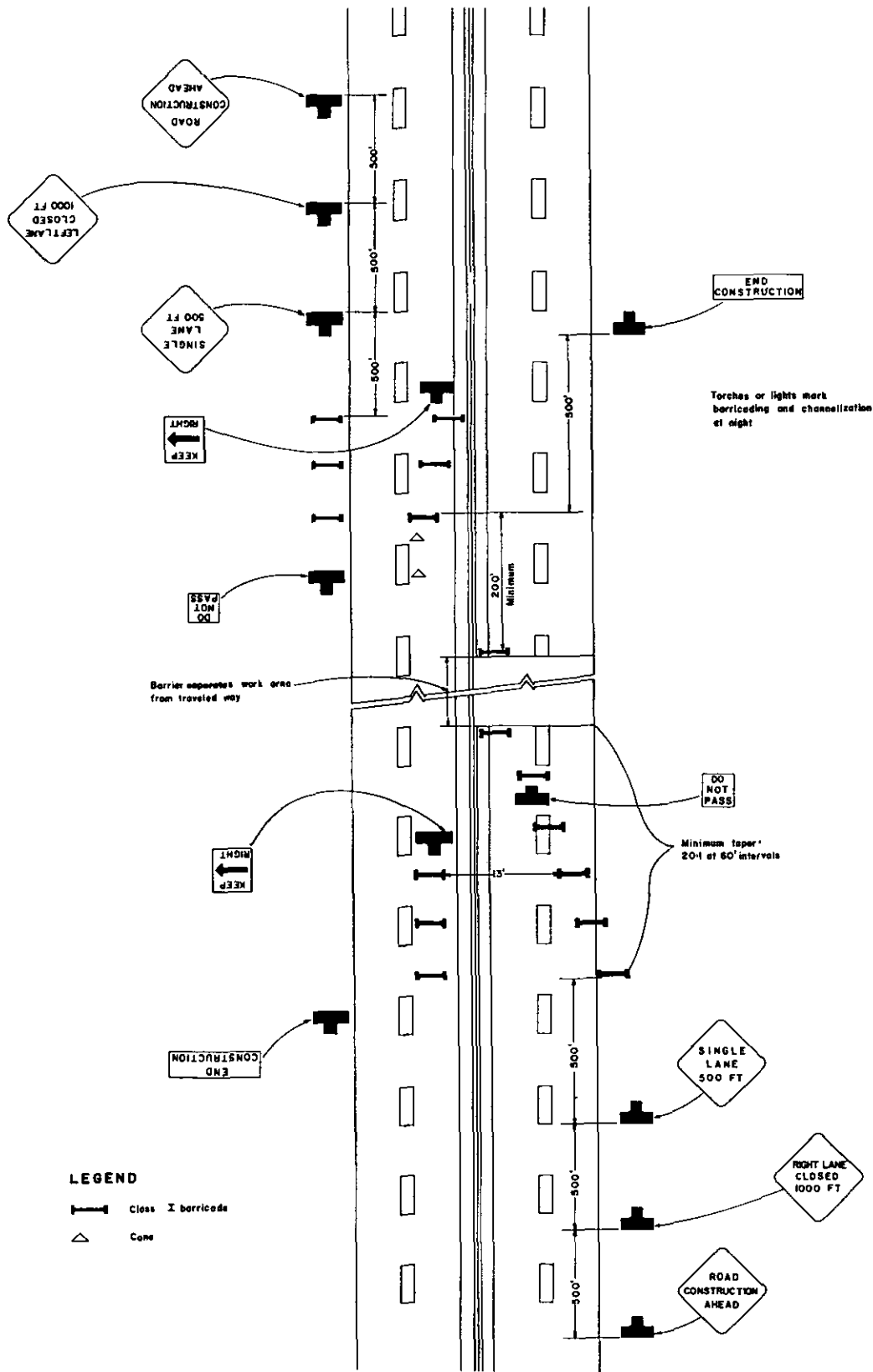


Figure 43. Example of a cross over on a 4-lane high speed road.

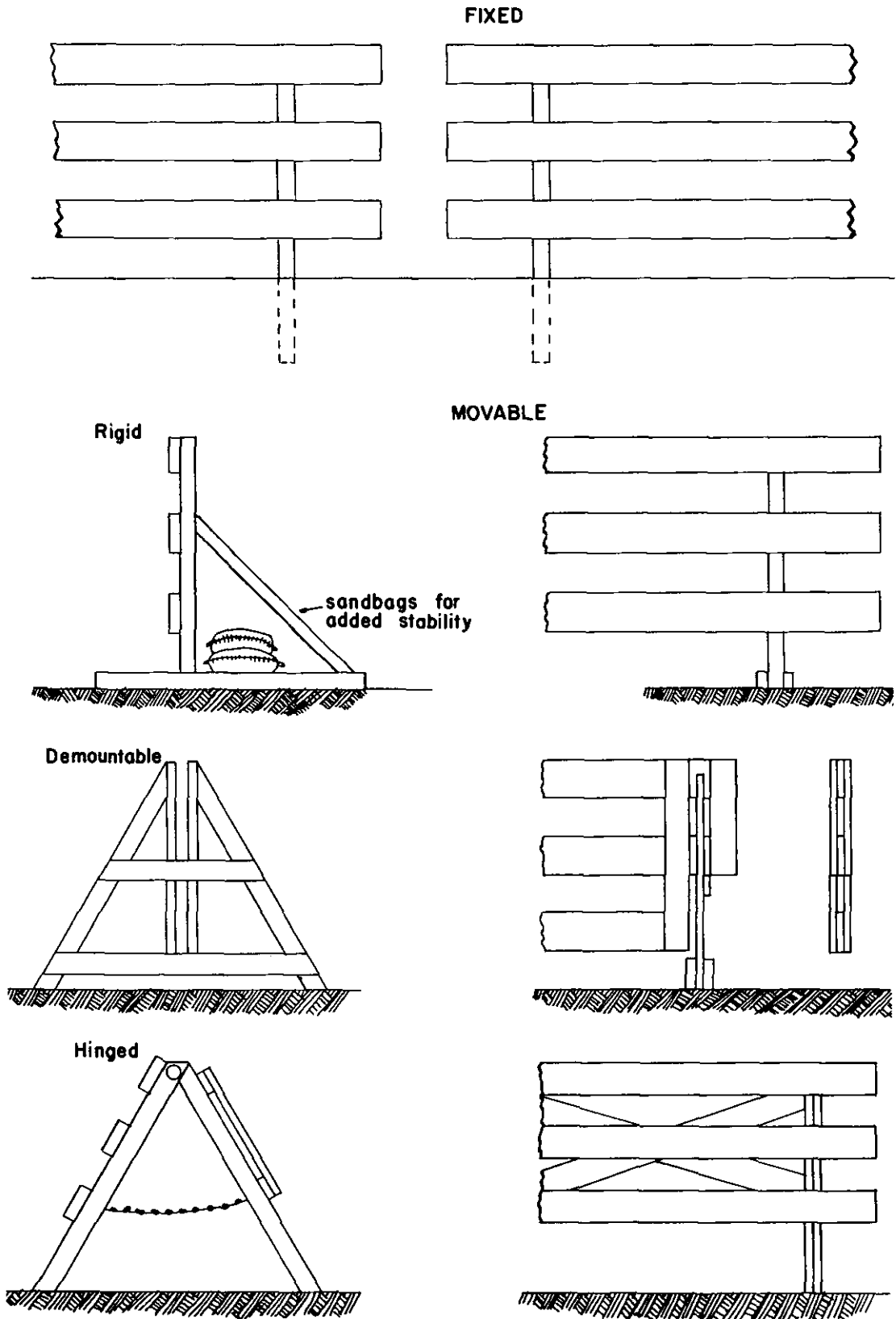


Figure 44. Class I barricade.

trol personnel at the ends of a detour, groups of vehicles can be started alternately from each end of the detour.

- (6) *Turnout.* A turnout in the middle of a long detour makes it possible to start groups of vehicles from both ends simultaneously. The first group to reach the turnout pulls completely into it, thus permitting the group moving in the opposite direction to continue. As soon as the end of the moving group has passed the turnout, the

parked group emerges from the turnout and completes its movement. Control personnel will be required at the turnout. This technique makes maximum use of road space in a long detour; however, it can create traffic jams if it is not carefully executed. If the danger of bogged or disabled vehicles is present in the detour, the turnout technique may be inadvisable, since the turnout area may be required for repair or recovery operation (fig. 45).

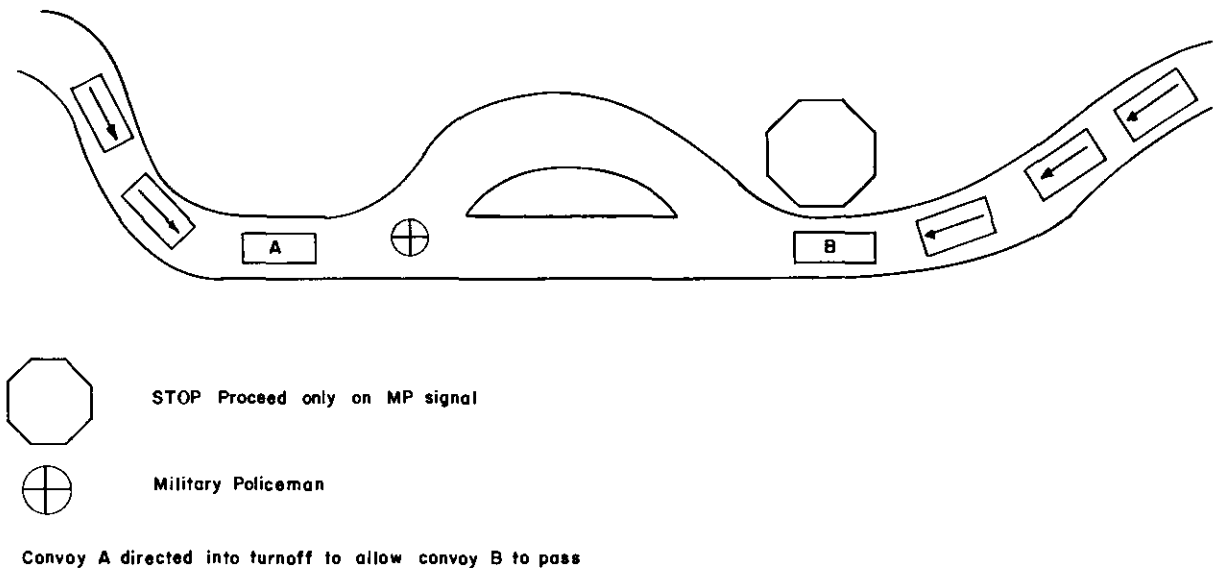


Figure 45. Detour using a turnout.

Section V. MISCELLANEOUS OPERATIONS

101. Vehicle Inspections

a. Under various army programs motor maintenance personnel perform roadside spot checks on the maintenance of military vehicles. The military police support this program by providing traffic control to allow safe movements of vehicles to and from the roadway and the inspection point. During the period that the vehicle is being inspected, the military policeman conducts a check for compliance with traffic and vehicle regulations. This check includes driver license inspection, dispatch authority, and other such requirements.

b. When directed, the military police will inspect privately owned vehicles registered with the military. The military policeman will normally supervise the inspection and deal with the individual vehicle operator, while a trained vehicle inspector will perform the detailed mechanical and technical inspection. Local SOP will provide the detailed guidance needed. While the military policeman does not make the mechanical or technical inspection he must have sufficient understanding of the inspection so that he can deal with the vehicle operator. When in contact with the vehicle operator, the military policeman must be courteous yet firm.

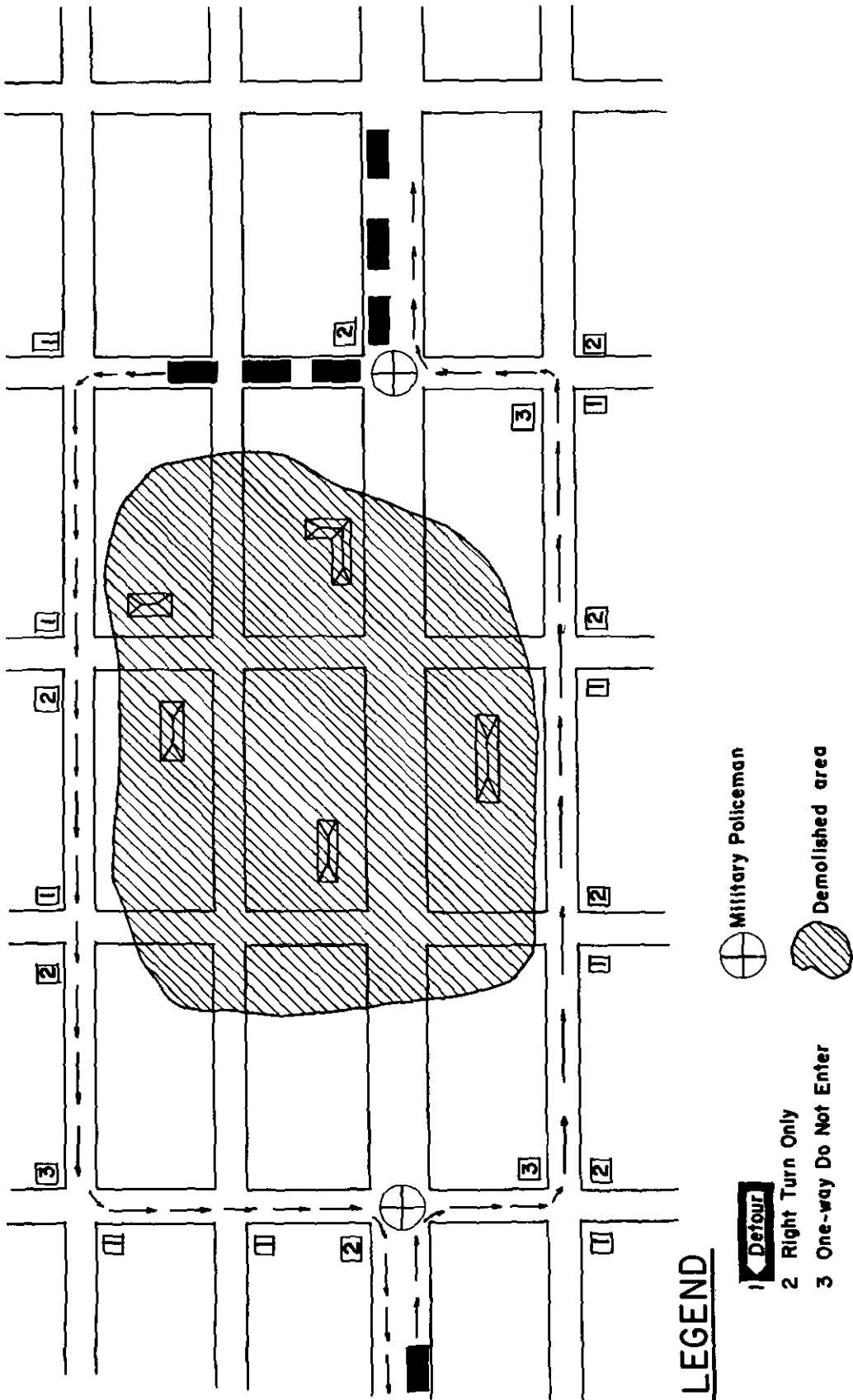


Figure 4.6. Example traffic rerouting.

While the vehicle is being inspected, a check should be made for compliance with traffic and vehicle regulations. All deficiencies must be reported. Appropriate forms will be locally supplied.

102. Assistance to the Fire Department

a. Military police on traffic duty will assist in providing the right-of-way for the fire department. While answering an alarm, a fire department vehicle displaying its warning light and audible sound must receive the right-of-way from other vehicles. The Uniform Traffic Code prohibits a vehicle from following within 500 feet of a fire department vehicle answering an alarm. A military police patrol proceeding to a fire scene should stop only to take action on a major violation. Otherwise, the military policeman will make note of the violator's registration, date, time, location and nature of the violation, and continue on to the fire scene.

b. In establishing traffic control at a fire the military policeman will be guided by the purpose of preventing congestion. If necessary, traffic should be immediately diverted from the area. In an area with a block pattern of streets, traffic should be diverted to the right (fig. 46). Using this system, traffic will follow a circular pattern around the area. During this operation, traffic will not be allowed to park, stop or slow down. If this occurs, congestion will increase and will hinder the fire fighting effort. No vehicle should be allowed to pass over an unprotected fire hose.

c. When a military policeman discovers a fire, his first responsibility is to save human life, if possible. He should alert building occupants by sounding an alarm if one is available or by other means, then report the fire, and within his capability attempt to control or extinguish the fire. Upon arrival of the fire department the military policeman will assist the officer of the fire department who is responsible for all activity at the fire scene.

103. Civil Defense

When a natural or man-made disaster takes place, the civil defense organization assumes a major role. Often under these circumstances the military police and civil defense organization

are required to work closely together. It is mandatory that the individual military policeman understands the local civil defense traffic system and, in particular, special civil defense road signs (fig. 47). Local SOP will prescribe military police training and action.

104. Roadblocks

a. Roadblocks are normally established to apprehend a criminal or to seal off an area in which a crime has been committed. Usually two or more motor patrols are used to form a roadlock, however, one patrol may be used.

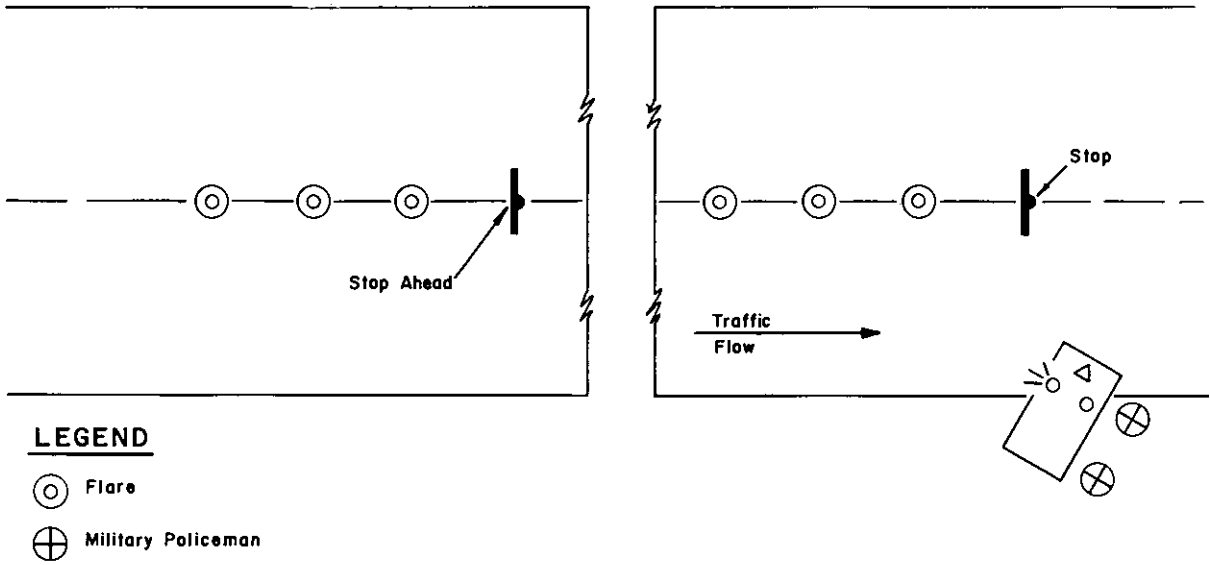
b. Military police headquarters normally will direct roadblock operations by radio. The headquarters will assess the need for additional military police, insure that all available information is disseminated to personnel participating in the operation, and maintain a roadblock operation center according to local SOP.

c. Ideally, the roadblock should be established at a location that will provide cover for the military policeman and minimize the risk of innocent personnel becoming involved or injured in the event of violence.

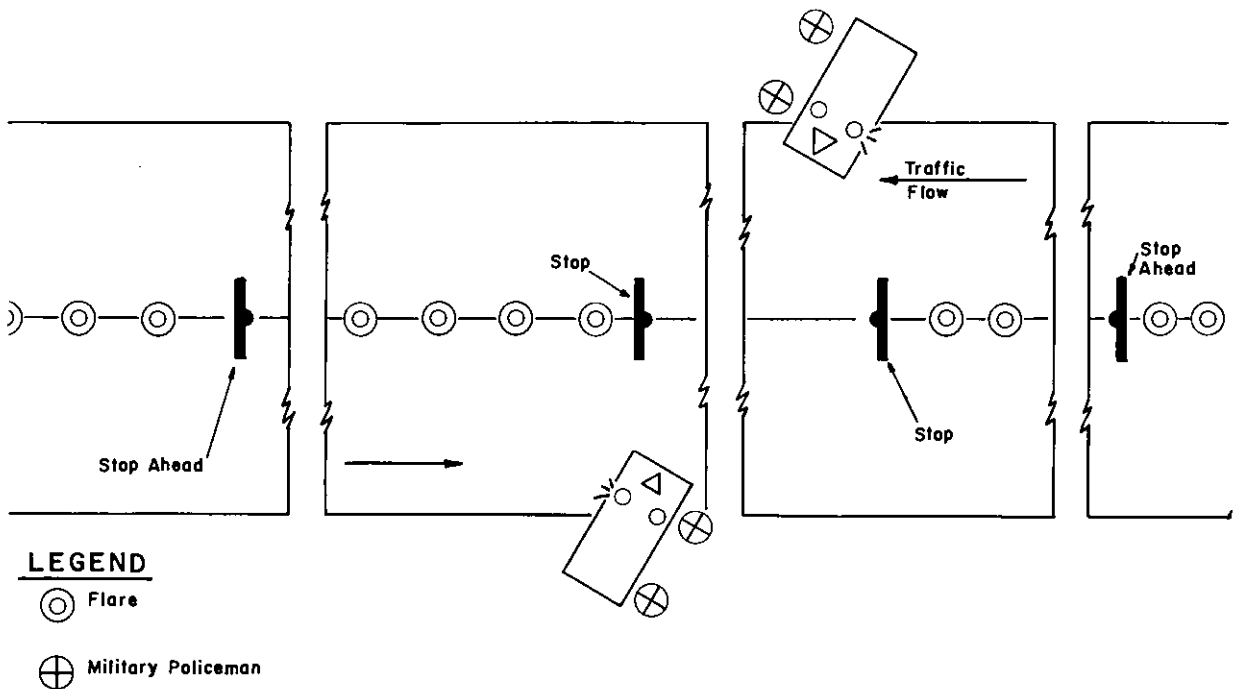


24" X 30"

Figure 47. Example of civil defense road signs.



TO STOP TRAFFIC FROM ONE DIRECTION ONLY



TO STOP TRAFFIC FROM TWO DIRECTIONS

Figure 48. Example of a two-lane road roadblock.

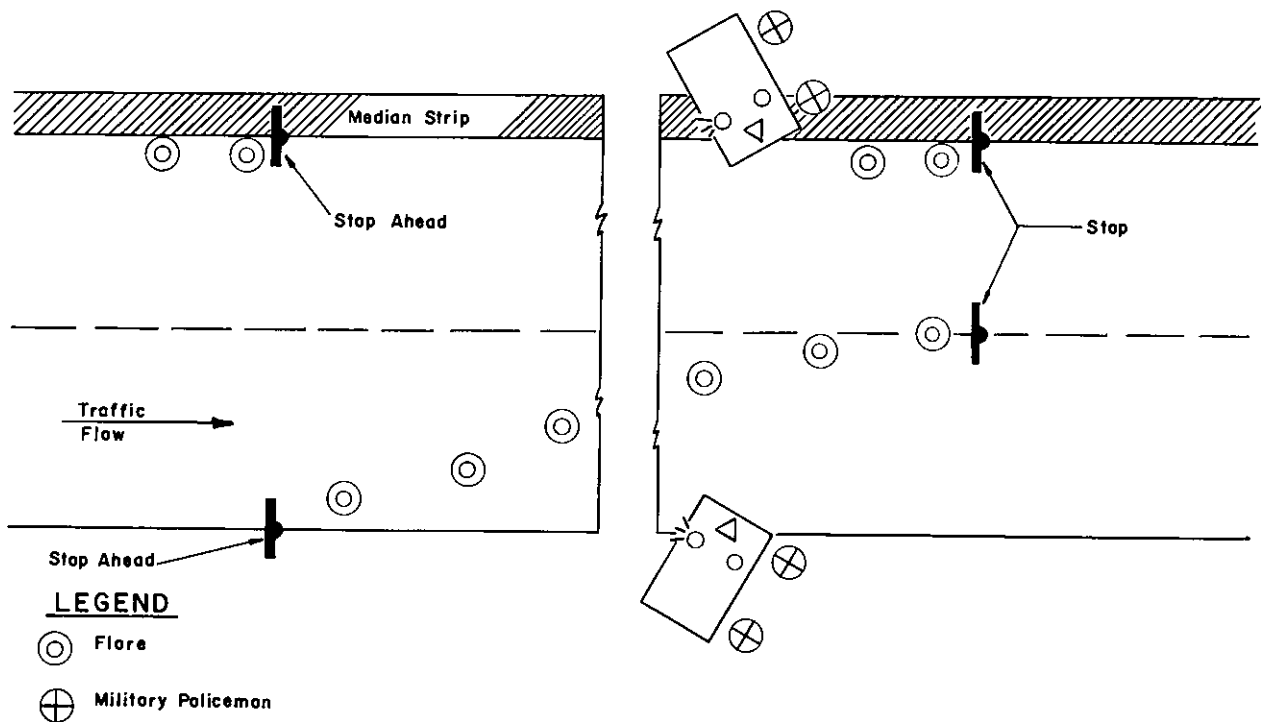


Figure 49. Example of a multilane road roadblock.

d. Roadblock operations are hazardous. Someone must expose himself to danger but the number exposed should be kept to a minimum. The location selected should have as many of the following characteristics as possible:

- (1) It should comply with appropriate local laws.
- (2) A straight section of the roadway should be selected as an accident prevention measure. However, this section should not be of such length as to allow U-turns or other evasive action by drivers approaching the roadblock.
- (3) There should be no access-egress road within sight of the roadblock.
- (4) The selected section of roadway should have ditches or other obstructions on the side of the road.

e. Roadblocks are organized according to the situation and the roadnet work.

- (1) *Two-lane road.* When it is necessary to block a two-lane road military police vehicles should be parked at 45°

angles to the roadway, partially blocking the traffic lanes. Warning signs should be placed in the center of the roadway (see section III for distances). The military police vehicles should be stationed or placed 15 to 25 yards apart (fig. 48).

- (2) *Multilane road.* It is usual when blocking a multilane road, to funnel traffic into one lane in each direction. An additional vehicle may be placed near the roadblock to be used to pursue vehicles which fail to stop (fig. 49).

f. Safety equipment, such as flares, traffic cones, temporary warning signs, etc., should be used to guide motorists through the roadblock.

g. When using rope, cables (A, fig. 50) or barricades (B, fig. 50) the safety of the road user must be considered. A large truck or tractor trailer may be used for lightly traveled roads or when a road must be completely blocked (fig. 51).

105. Public Information

a. When a military policeman is requested to comment, make a statement, or give information, he will refer such request to the information officer of the command.

b. The local SOP will prescribe the relationship with news media representatives on post. Incidents involving traffic will be handled in the same manner as other incidents and will be outlined in the local SOP.

c. Within the United States, off-post incidents are handled by the civil police. When the incident involves classified shipments, the military

police will be dispatched to protect the scene. News media representatives will be informed that the making of photographs, sketches, and other recordings of classified material is a violation of the Federal criminal statutes (Title 18, USC 795, 797). The military policeman will refrain from using force if news media representatives refuse to cooperate. The military policeman will request the assistance of the civil police and immediately report the details of the incident (AR 360-5.)

d. Operations outside of the United States will be outlined by the military police SOP and command regulations.

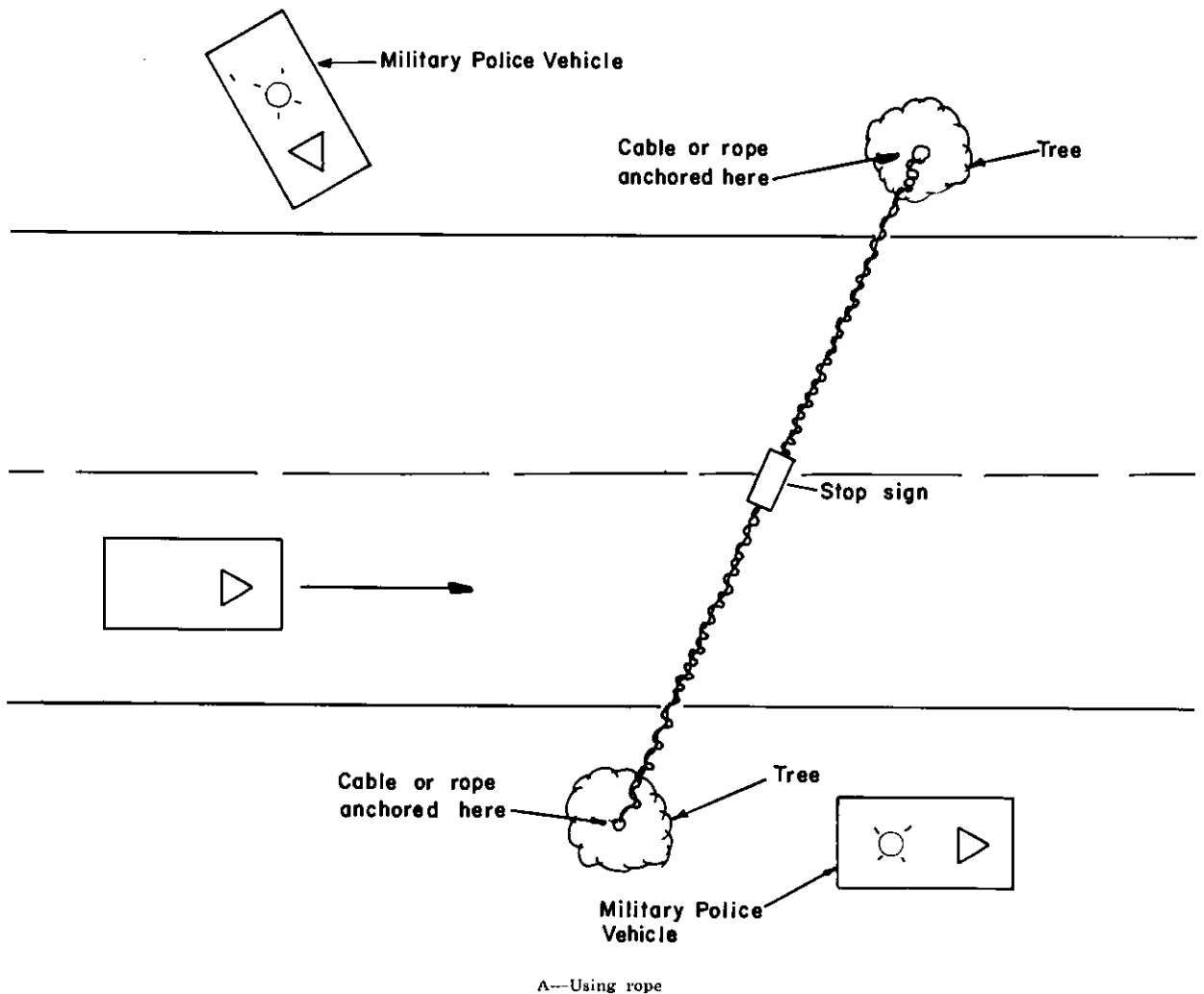
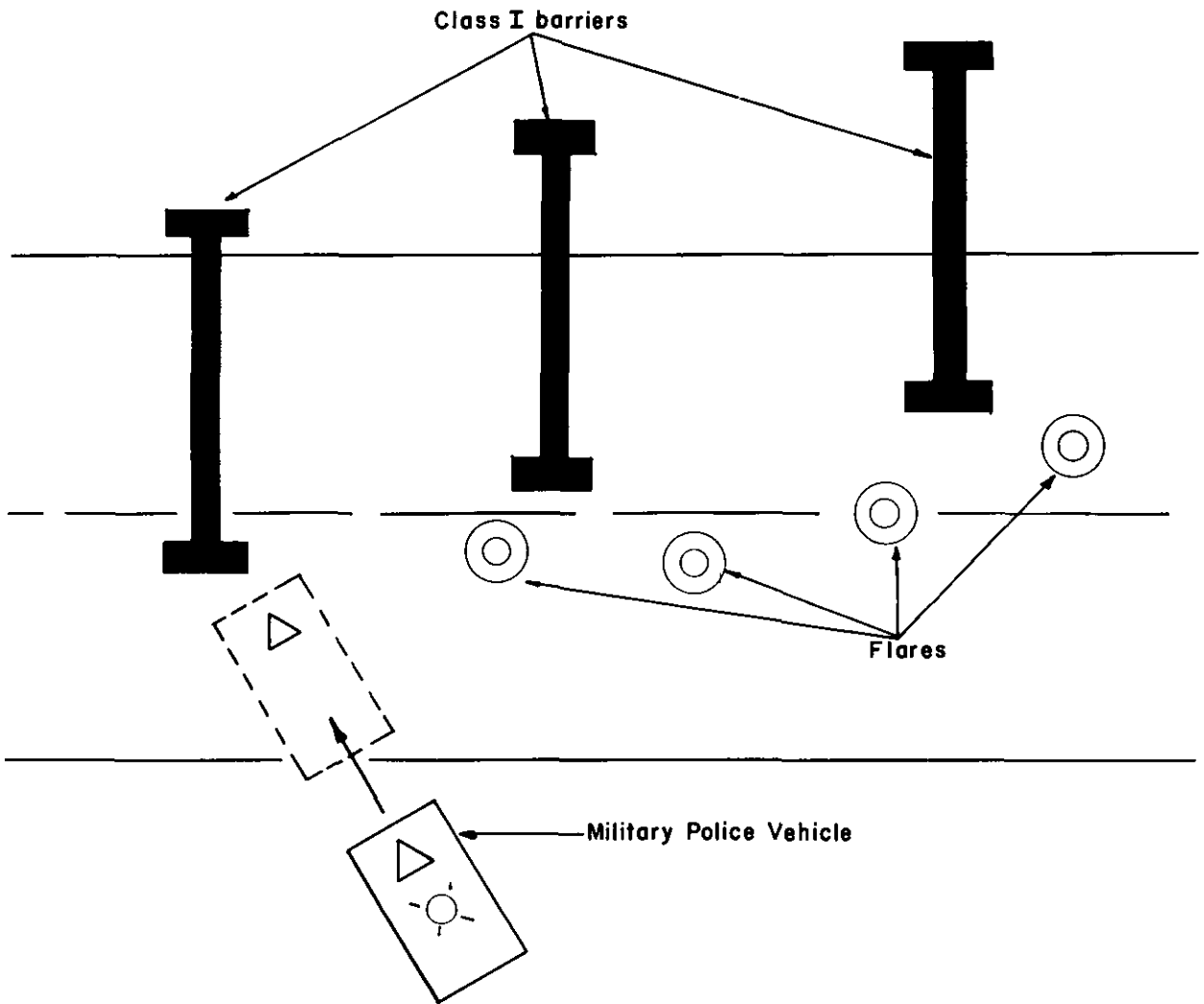


Figure 50. Example of a roadblock.



B—Using barricades

Figure 50—Continued.

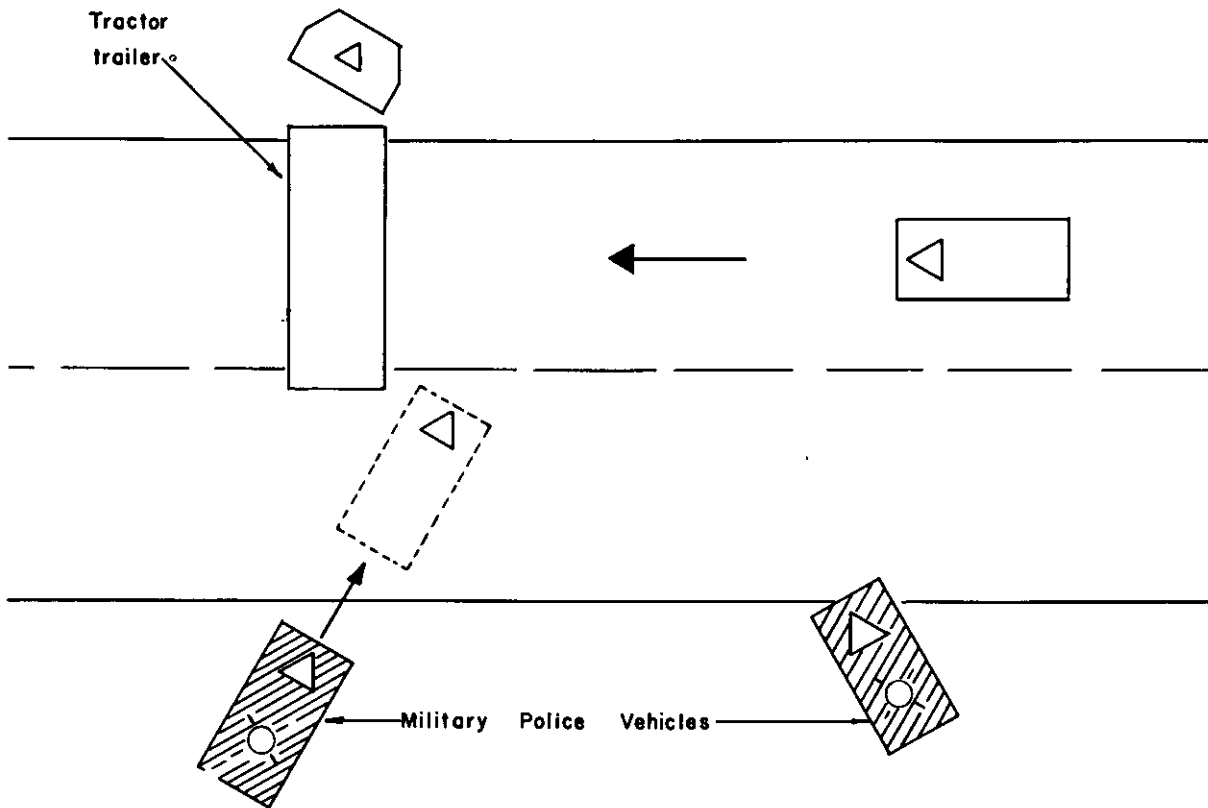


Figure 51. Example of a tractor trailer used as a roadblock.

PART THREE

THEATER OF OPERATIONS

CHAPTER 8

INTRODUCTION

Section I. GENERAL

106. Principles

a. The primary movement of men and material in theater of operations is on the ground. Increasing numbers of motor vehicles while providing increased ground mobility, have compounded the control problem of the commander. One of the major tools the commander has available for use in ground mobility control is the military police unit.

b. The general principles of traffic control presented in the preceding chapters are valid in the theater of operations. While the principles are valid, the implementation and techniques of traffic control take on a new and expanded meaning.

c. The basic principle of traffic control within the theater of operations is to insure that traffic authorized the use of the road moves uninterrupted with a certainty of arrival of both vehicles and cargoes at their intended destination according to schedule.

d. In Part Two of this manual emphasis was placed on activities of the military policeman working alone or in pairs, since most traffic control actions conducted at a post, camp, or station require only one or two military policemen on a task. Ideally, traffic control in the theater of operations requires a team of 3 or more military policemen be used for each task (para. 118).

107. Highway Regulation

a. Highway regulation, primarily a Transportation Corps function (FM 55-31), is the planning, scheduling, routing, and directing of

the actual use of the highways by vehicles, personnel on foot (including troops, refugees, and others) and animals so as to meet military operational requirements. Highway regulation is deciding *who* is to use the road while traffic control is control of those using the road.

b. The following is a guide to the relationship between the military police and the road user:

- (1) The commander of troops using the road is responsible for tactical situations that may arise.
- (2) Commanders of units not complying with traffic regulations or schedules will be informed of the proper action. If the commander elects not to comply with the cited regulations, the military police will assist him to the extent of their ability and as soon as possible the incident will be reported to the military police unit, and should be made a matter of record.
- (3) Whenever possible, military police will assist personnel performing highway regulation duties. Close coordination and cooperation are essential.
- (4) Procedures for handling refugees and local inhabitants on the roads will be published by the military police unit. Civil affairs units normally have responsibility for these persons but military police units will take necessary action to control the roads.

108. Preparation

Individual preparation on the part of the military policeman in the theater of operation follows the same general line as for operations

within a post, camp, and station. While the general pattern is the same, specifics are different. In place of the military police leather-type of equipment, the military police wears the same equipment as other soldiers. To distinguish him from other soldiers, he wears the military police brassard, and his helmet is marked according to AR 670-5. Those military police assigned traffic type duties will also be equipped with luminous sleeves. These indicate to both US forces and many US allies that the individual wearing these items is responsible for the control of traffic. Other equipment such as flashlights, automatic weapons, vehicles, and communication equipment, is prescribed by the TOE for each military police unit.

109. Briefing

a. Of primary concern in the preparation of the military policeman for traffic control duty is the briefing that he receives. This briefing may be conducted in the format of an operation order (for detail, see FM 101-5); it may be a published order supplemented by oral instructions; or it may be simply an oral order. The extent of the briefing is determined by the situation. While it is highly desirable for all military police involved in a task to receive the same briefing, often due to security, time or space, the briefing is given only to the team and squad leaders. These leaders will insure that all military police are briefed on their duties. The briefing should follow as closely as possible the following organization:

- (1) Title or general description of task.
- (2) Maps that are necessary for the task. This includes overlays, strip maps, and sketches.
- (3) Organization of the military police for this task. This spells out where each man is assigned and provides a designation for each team.
- (4) The traffic and road situation. This is a summary of the traffic control plan, the highway regulation plan, the refugee movement plan and the results of route reconnaissance as they affect the mission to be accomplished.
- (5) The enemy situation. A briefing of enemy activity in the area. It also includes a summary of what can be an-

anticipated from the enemy in the immediate future. Possible nuclear activity, chemical/biological activity and air activity will be discussed.

- (6) Weather. This is restricted to the information that has a direct effect on the use of the road, such as expected precipitation, cloud cover, temperature, wind, and periods of light and dark.
- (7) Friendly situation. The location of those activities that can render assistance or service. Such activities would include ordnance units for wrecker service, medical units for emergency aid, and adjacent or nearby units that can reinforce the military police. Included also is a briefing of all points and units whose locations the military police need to know to perform their information function. This information usually is presented by means of a map or overlay.
- (8) Mission. This is a detailed spelling out of the task the military police will perform. It answers the question WHAT, WHEN, WHERE, and sometimes WHY.
- (9) Specific tasks. Under this heading each squad, team, and individual is told what he is to do and how it will be done.
- (10) Coordinating instructions. These are instructions that are applicable to two or more individuals or teams. Examples of such instruction would be changes to the SOP, emergency re-routing instructions, straggler and refugee disposition, and similar type information. When the military police duties involve movement schedules, appropriate instructions are published or may be issued as an annex to written orders.
- (11) Logistics. Information is furnished concerning resupply, maintenance, water sources, and meal planning.
- (12) Signal. An excerpt of the SOI that is to be used by the military police will be issued. It will contain radio call signs, frequencies, and authentication tables.

- (13) Command post. The last normal item of a briefing is the announcement of the location of the military leaders and commanders involved during the time the mission is to be accomplished.

b. The preceding subparagraph presents most areas of interest to the military policeman detailed to perform a mission; however, it may be necessary to issue some of the above information and instructions and other special considerations as annexes to written orders or as a special briefing. When military police perform repetitive or constant type duties, a printed collection of information and instruction may be issued to the military policeman as an SOP.

110. Priorities of Traffic Movement

Priorities are established to insure that essential movements are made. Priorities are necessary where the road net will not accommodate all of the traffic which desires to use it. The enforcement of movement priorities is a function of military police traffic control personnel.

111. Types of Movement Priorities

a. *Specific movement priorities* are given for a specific move or operation. They are announced by the military police unit after re-

ceipt from higher headquarters. Such priorities list types of vehicles, supplies, personnel, or combination of these, and their order of priority. Vehicles that have priority will have the priority number marked in chalk on the side or the content listed in chalk on the side. An example of a specific priority list is shown in figure 52.

b. *General movement priorities* are routine guides to traffic control personnel, highway traffic regulating personnel, and commanders of units using the roads. In the absence of specific instructions to the contrary, military police will apply the following general priorities, with on-the-spot changes that are required to keep essential traffic moving in an orderly, efficient manner:

- (1) The movement of tactical troops.
- (2) Ordnance recovery and engineer equipment going to the scene of traffic obstructions.
- (3) Ambulances and other vehicles being used as ambulances.
- (4) Wire patrols and communications crews.
- (5) Command, staff, and messenger vehicles not in convoys.
- (6) Supply convoys.

HEADQUARTERS
24th Military Police Group
APO 999
US FORCES

MOVEMENT PRIORITIES:

Effective 260001 March 68 till 272400 March 68

1. The following priorities of movement will be enforced by military police traffic control personnel through the 24th Military Police Group Area.

Vehicles with movement credit 15-USM-09
Ambulances East bound
Tankers (gasoline, oil, and fuel) West bound
Red and White Disk vehicle

2. General priorities outlined in FM 19-25.

THOMAS
Col

Official

Sean
S3

Figure 52. Example of daily specific movement priorities announcement.

Section II. ROLE OF MILITARY POLICE PLATOON AND SQUAD

112. General

A military police unit is not normally assigned an exclusive functional mission such as traffic control. Rather, the military police unit provides military police functions and activities on an area basis. The military police platoon is the basic unit of employment by the company. Platoons are normally assigned an area of responsibility on a mission type order with supplementary instructions.

113. Planning for Employment of a Platoon

a. Upon receipt of orders the platoon leader analyzes the order and makes an estimate of the situation (FM 101-5).

b. Particular areas of traffic interest to the platoon leader include:

- (1) Assigned mission of the platoon.
- (2) Positions or activities that the military police company has specifically directed.
- (3) The results of route and area reconnaissance.
- (4) Anticipated road use.
- (5) Intelligence reports and predictions of enemy activity.
- (6) Availability of traffic control equipment that would reduce the need for manpower.
- (7) The equipment and the number of military police available.

c. Squad and team integrity is maintained whenever possible.

d. The platoon leader issues detailed oral orders to the squad and team leader. These orders follow the briefing format presented in paragraph 109 (also the operation order in FM 101-5).

114. Duties of the Platoon Leader and Platoon Sergeant

a. The platoon leader and platoon sergeant

must be capable of relieving each other. A platoon command post is established at a critical traffic post or other position where either the platoon leader or sergeant is located while the other is patrolling the platoon area.

b. Constant checking, supervising, and adjusting of traffic control activities are the principal duty of the platoon headquarters. These include—

- (1) Determining that equipment is operational and personnel are performing assigned duties.
- (2) Realigning traffic control to adjust to changing traffic conditions.
- (3) Directing military police activities during an enemy attack.

c. The platoon headquarters is the principal source of information on traffic control. It must keep the parent unit informed of its commitments and its current capability.

115. Platoon CBR Activity

The platoon headquarters is normally equipped with a radiological monitoring instrument and a chemical detection kit. This equipment is usually carried by the element of the platoon headquarters on patrol. By such an assignment the military police unit achieves area coverage in reporting chemical and radiological contamination. This action may relieve the military police unit of furnishing survey teams to the damage control center.

116. Squad

Military police assigned to traffic control duties are normally employed as squads. Escort and defile duties lend themselves to the employment of an entire squad. TCP and motor patrols each usually employ a team; however, when assigning tasks the platoon would assign elements of the squad to adjoining posts or areas, to maintain unit integrity and facilitate control.

CHAPTER 9

TRAFFIC CONTROL POSTS

117. General

Traffic Control Post (TCP) is a point located on the ground where the military police control traffic. The selection of the location of the TCP is made by the military police unit or by military police planners at a higher headquarters. The TCP is established only where it is necessary for the control of traffic, to expedite it, and to prevent congestion. While performing its principal function the TCP also acts as a security point and performs other military police functions.

118. Organization

a. A type TCP team is composed of a senior military policeman and three other military policemen. Often there will be more than four military policemen assigned to this duty. The team must be provided with the means of traffic control, communications, and security for continuous operations.

b. When organizing a traffic control post the key word "METT" may be used as a guide for making an estimate of the situation. (For detail on making an estimate of the situation, see FM 101-5.)

- (1) *M* stands for Mission to be accomplished. While the mission may be simply stated as, "establish a TCP," there may be many induced tasks, such as the TCP acting as a counter guerrilla post.
- (2) The *E* stands for the Enemy and his capability. Enemy capability must be considered and counter action must be evaluated.
- (3) The first *T* introduces the consideration of the Terrain. The primary consideration is given to the road net, including bypass roads and holding areas (para. 109 and 121).

(a) When estimating the influence of terrain, the following list will serve as a guide (for detail, see FM 7-11):

1. Observation and fields of fire.
2. Concealment and cover.
3. Obstacles.
4. Key terrain features.
5. Avenues of approach.

(b) While not listed as an element of terrain, weather is another important consideration that affects the organization of a TCP. The weather often has a direct influence on the use of roads and is an important consideration in security (para. 109).

(4) The last *T* is used to call attention to the Troops available; this is often a limiting factor.

c. Considering all the factors, tasks are assigned to each individual and equipment is allocated to accomplish the mission. Using the four man teams as the type TCP, task assignment considerations would involve:

- (1) The assignment of one man to actually control the flow of traffic. His position in the roadway or intersection is determined in the same way as an individual engaged in point control (chap. 3). When he is not engaged in actual control of traffic, or during periods of attack, he will be located in a defensive position close to the roadway.
- (2) All around security is provided by assigning one man at a security post. The selection of the site of this post will be based on the terrain. If possible, this individual should be located where he can cover the military policeman performing traffic control and serve as an observer over likely avenues of approach. A means of signal-

ling and communication must be established between this post and other members of the team.

- (3) The third man of the team performs a number of functions. Normally, he is the senior military policeman of the team. The classified or sensitive material of the team such as maps, codes, and schedules are in his custody. Also under his direct control is the means of communication with his supervisor. As a general principle, persons seeking detailed information are directed off the travelled roadway to this individual. His position should have as many of the following characteristics as possible:
 - (a) A good location for communication. This is very important when radios are the means of communication used by the TCP.
 - (b) A location from which he can readily control and supervise the other military policemen.
 - (c) A location which offers good defense, to include cover and concealment.
 - (d) A location with sufficient area to park vehicles and to hold individuals such as stragglers.
- (4) The fourth member of the team is normally located at a position in the immediate vicinity of the senior military policeman. This position is used for a rest position, and the only time he is normally engaged is during an attack or other emergency. While the principal task of this military policeman is to rest and prepare for duty, his location adds strength and security to the position of the senior military policeman.

119. Equipment

a. Ideally, every TCP should be equipped with multiple means of communication; as a minimum it normally will have a radio and should have a telephone if practicable.

b. Dependent on the mission, the military police unit and the area of operation, automatic weapons may be issued to the TCP. The loca-

tion of an automatic weapon is based on the METT. Often, to strengthen the team position, an automatic weapon is located with the senior military policeman.

c. Signs are tools of traffic control used in the theater of operation as well as in post, camp, and station conditions. The principles of temporary sign posting outlined in chapter 7 are applicable. A supply of temporary traffic control signs and CBR warning signs should be available at a TCP.

d. Other material such as POL, water, rations, and tools must be available to a TCP. See appendix IV for a checklist of equipment.

120. Function of a TCP

a. The primary mission of any TCP is traffic control which insures traffic moves to its destination without delay or congestion, according to routing and scheduling instructions and in compliance with traffic rules and regulations.

b. Each TCP must serve as an information post. This not only involves the capability of giving directions to those who have a need for them but also includes supplying information on road conditions, enemy activity in the area, and information issued by higher headquarters for dissemination to the road users. The military police should gather from the road user as much information as possible, without interrupting traffic, and forward it to the next higher headquarters. The TCP also reports information of nuclear, biological and chemical (NBC) activity. To perform this function every military policeman should be able to complete the NBC basic report (FM 3-12).

c. In common with most military police activity, traffic control has an intelligence aspect. By such action as observing and reporting of movements, the actions of the area's inhabitants and by questioning road users, the military police adds to the intelligence gathering activities of the Army. A positive contribution to counterintelligence effort is made by the military police by their enforcement of passive defense measures which include light lines, convoy discipline, and vehicle security. In all these activities, the military police attempt to deny information to the enemy.

d. The TCP is a natural counter guerrilla post. While not capable of withstanding strong and prolonged attack, the traffic control post can serve as a temporary block to guerrilla activity. The location of a TCP, with reasonable defense and good communications, effectively denies the use of that area for a surprise guerrilla movement. Its ability to gather information and intelligence are useful in locating guerrillas as the first step to their elimination. A well-organized TCP may serve as a base to organize forces to defend against an attack and prepare to counterattack.

e. Checkpoints (para. 151) are a specialized function of military police; however, each traffic control post performs some of these functions:

- (1) Checking convoy clearances to insure proper use of the road.
- (2) Inspection of a questionable vehicle or convoy concerning its authority to travel, its destination, and the equipment or cargo to insure compliance with current orders.

f. All traffic control posts serve a secondary function as straggler control points. The personnel assigned to a TCP will perform those straggler control duties outlined in FM 19-5. A straggler holding area will be designated within the TCP area.

g. The military police assigned to traffic control will implement the movement plan for refugees within their area. The principal duty of the personnel of a TCP in refugee control is to insure that refugees use only the road assigned to them and do not interfere with military movements.

121. Holding Areas

When establishing a TCP, the senior military policeman plans a tentative holding area, an area where traffic can be moved off the road in case of attack or congestion, or while awaiting the proper time to clear the TCP. General principles for establishing a holding area are:

a. Density and dispersion of vehicles within the holding area will depend on the tactical situation.

b. It must be located for easy exit from, and entrances to, the roadway.

c. The surface of the area should be firm enough to sustain the weight of military vehicles.

d. In organizing the area:

- (1) Vehicles should be parked in a manner that will allow the first vehicles in to be the first vehicles out.
- (2) Roadways should be established to allow ease in moving selected vehicles out of the area.

e. The area should be large enough to allow dispersion and if possible concealment from casual air or ground observation.

f. The military police should prepare a defense plan to provide for uniting all road users in the holding area into a team to establish a strong point in case of enemy attack.

g. When it is practicable the senior military policeman is located in the vicinity of the holding area.

h. For a large holding area, it is necessary to develop a control plan. The simplest method of control is to use a subdivision system. To utilize this system the following steps should be taken.

- (1) Produce a map or draw a sketch of the area showing the trails and road net plus major obstacles. If available a 1:25,000 map should be used.
- (2) Outline the holding area.
- (3) Divide the area on the map or sketch into equal subdivisions approximately 250 meters square and assign a letter to each subdivision.
- (4) On the ground erect signs showing the outline of each area.
- (5) Develop a traffic flow plan, record it on an overlay of the holding area map, and erect necessary signs to assist road users in understanding the plan.
- (6) Maintain a count by number, size, and unit designation of each vehicle in the lettered subdivision.

122. Rerouting

a. Rerouting of traffic is normally the responsibility of the military police unit or higher headquarters. The TCP must be prepared to

initiate minor rerouting and to implement planned rerouting.

b. Since traffic rerouting affects the traffic plan its implementation must be coordinated. The following is a guide to coordination:

- (1) When time permits, rerouting, no matter how minor, will be approved by the next higher headquarters prior to being placed in effect.
- (2) The TCP may reroute the traffic that affects only that TCP, provided travel time is not increased by more than five minutes.
- (3) Traffic may be rerouted on an emergency basis by adjoining TCP provided it is coordinated between them and area patrols and the travel time is not increased more than five minutes.
- (4) Platoon leaders and platoon sergeants may direct an emergency rerouting of traffic within their area when the travel time is not increased by more than eight minutes.
- (5) When an emergency rerouting of traffic affects two platoons or larger units, it must be effected by the controlling headquarters of the units involved.

c. Each TCP must be capable of functioning under a rerouting situation. The following considerations apply:

- (1) TCP personnel must have a knowledge of the area in the vicinity of their position so that they can utilize the best roads for rerouting.
- (2) Equipment for a TCP will include sufficient material to provide for route marking of any rerouting.
- (3) Strip maps of the rerouting will be prepared by the military police at the TCP if not prepared by MP headquarters.
- (4) During an emergency it may be necessary to establish temporary TCP to provide for an efficient rerouting. Under this type circumstance the principles for establishing a TCP as outlined in paragraph 118 may have to be modified due to lack of personnel and equipment.

d. The MEASLE map system may be used in rerouting (app. VII).

123. Role of a TCP During a Nuclear Attack

a. The traffic control point must constantly maintain passive defense measures to minimize the effects of a nuclear attack. The preparation of position and plans for defensive positions for road users are actions that the team takes as a unit. Individuals as a part of a team maintain a passive defense posture and take those steps outlined in FM 21-41, to reduce the effects of a nuclear attack.

b. When a nuclear attack has occurred the TCP will submit an NBC report as soon as practicable, with followup reports when possible to the military police headquarters. The senior military policeman will prepare to activate the planned straggler collecting area. The TCP will take initial steps to activate the holding area and prepare to reroute traffic; however, every effort should be made to keep traffic moving on the routes currently in use.

c. A TCP will displace only on order. If fallout occurs, protection can be achieved in the prepared defensive position. Personnel will prepare to resist enemy efforts to exploit the nuclear attack.

124. Operation Under Blackout Conditions

a. Blackout conditions will be announced in the appropriate operation order. These conditions increase requirements for strict control of the traffic flow and traffic regulation as well as creating a security problem.

b. The blackout conditions considered herein are not total blackout but are defined as "movement by night with lights which cannot be spotted by enemy observation, but which enable collisions to be avoided by showing the position of the vehicle to other road users." (STANAG No. 2024, Ed 2.)

c. Depending upon security requirements, the military policeman may use the flashlight baton or wear the reflectorized sleeves and cross straps as an aid to controlling traffic. The operation order will specify those signs that are to be illuminated. Primary consideration is normally given to danger and warning signs which are placed with the object of preventing accidents, and signs that announce a choice or change in direction. Requirements for illumination are as follows:

- (1) The sign will be provided with an upper mask which will prevent the light from being seen from above. An observer flying higher than 150 meters must not be able to see the light or its reflection.
- (2) The light will be oriented so that it is visible on the ground a minimum distance of 100 meters and readable at a distance of 30 meters.

d. Vehicles operating under blackout conditions will meet the following requirements:

- (1) Vehicle lights will be positioned so that the width of the vehicle will be delineated from either the front or the rear.
 - (a) Vehicles with 3 or more wheels will display two white or yellow lights at the front and two red lights at the rear.
 - (b) Motorcycles without sidecars may be equipped with a single headlight and a single rear light.
- (2) Vehicle lighting should be diffused. The lighting devices will be provided

- with effective masks to prevent the lights from being seen from above.
- (3) The lights shall be visible a minimum horizontal distance of 50 meters and maximum of 250 meters.
 - (4) Vehicles traveling in convoy meet the lighting requirements by displaying—
 - (a) Two white or yellow lights at the front of the first vehicle of each element.
 - (b) Two red lights at the rear of the last vehicle of each element.
 - (c) At least one light at the rear of each vehicle to permit the driver of the following vehicle to judge the proper distance.

125. Reduced Lighting

Military police may also be required to operate during “reduced lighting” conditions. Under these conditions the brightness of all exterior and interior lights is reduced. Specific requirements will be published by higher headquarters, and will vary with the situation. (STANAG No. 2024, Ed 2.)

CHAPTER 10

MOTOR PATROLS IN THEATERS OF OPERATION

126. General

The military police motor patrol is normally the predominant means of traffic control. Knowledge of the area, mobility, and communications, inherent with the normal patrol, provide a versatile tool for use by the military police unit in its role as an element of command control.

127. Organization

a. A type motor patrol is a team of three military policemen. Under normal operating conditions this team is capable of 12 hours continuous duty in 24 hours. Within the 12 hours, time is allocated for meals and first echelon vehicle and radio maintenance.

b. The senior military policeman normally rides in the right front seat of the vehicle to provide for control and observation.

c. The driver performs the principal task of driving, however, he may also assist in observation and reconnaissance.

d. The radio operator/recorder maintains constant monitoring of the MP radio net. This duty includes responsibility to prepare, send, and receive radio transmissions, record reconnaissance information, complete NBC reports, draft patrol reports, record instructions, post patrol maps, and provide flank and rear security observation for the patrol.

128. Equipment

a. Basic equipment for an MP patrol will be a vehicle and radio. Both the 1/4-ton and 3/4-ton vehicles are well suited to meet the military police requirements. The radios provided in military police TOE are designed to fulfill operational requirements.

b. Weapons assigned to a military police patrol are the individual weapons of the team

members, and may be augmented with an automatic or a crew-served weapon. Additional fire support is achieved by the use of grenades.

c. Other equipment is shown in the "equipment checklist" for a military police patrol (app. IV).

129. Functions of a Military Police Traffic Patrol

a. The primary function of the military police traffic patrol is to provide traffic control within its assigned area. Additionally it has the mission of maintaining contact with TCP and other military police activities in its area. Traffic patrol contacts serve to assist the military police headquarters to coordinate the military police effort. A patrol in the theater of operations enforces traffic regulations in a manner similar to that of a post, camp, or station patrol (ch. 4). Local instructions will prescribe the detail in which reports on traffic control will be submitted. For instance, within the field army area, accidents that do not involve loss of life will often require only the identification of the participants and the time, date, and location of the accident. When military police are operating as part of a NATO (North Atlantic Treaty Organization) force, they will use the NATO Standard Offense Report (fig. 53).

- b.* Additional motor patrol functions include:
- (1) Performing as a TCP during emergencies when congestion arises or when ordered by the military police unit.
 - (2) Encouraging the road users, by the presence and activity of the patrol, to voluntarily comply with the traffic regulations.
 - (3) Gathering current road information and reporting it to military police headquarters for use in planning. While designated patrols are dis-

NATO—UNCLASSIFIED

STANDARD LAYOUT FOR OFFENCE REPORT TO BE USED BY NATO TRAFFIC CONTROL

PERSONNEL
PRESENTATION STANDARD DE LA FICHE D'INFRACTION A EMPLOYER PAR LES
AGENTS DE CIRCULATION DE L'OTAN
OFFENCE REPORT / FICHE E' INFRACTION

This form will be sent through the normal military channels to the driver's Commanding Officer.
Cette fiche sera transmise par la voie hiérarchique à l'autorité dont dépend le conducteur en faut.

1. Date, time, place of offence†		/	Date, heure et lieu de controle†

2. Driver's name†	Nationality	(if military) Rank, Service No.* & Unit	
Nom du conducteur†	Nationalité	(pour les militaires) Grade, No Matricule* et Unité	
		(if civilian) address of employer	
		(pour les civils) adresse de l'employeur	

3. Name of vehicle commander†	Nationality	(if military) Rank, Service No.* & Unit	
Nom du Chef de la voiture†	Nationalité	(pour les militaires) Grade, No Matricule* et Unité	
		(if civilian) address	
		(pour les civils) adresse	

4. Particulars of vehicle checked / Caracteristiques du véhicule contrôlé.			
a. Make / Marque			
b. Type / Type			
c. Registration No / No Matricule			
d. (Address of unit or civil owner)			
(Affectation du véhicule ou adresse du propriétaire)			

5. Offense observed		Infraction constatée	
(Detailed statement of evidence to be given)		(Constat détaillé)	
(x)			
6. Action taken		Mesures prises	
(x)			
7. Name, rank, service No & Unit		/	Nom, grade, No Matricule et Unité
of traffic control policeman†			de l'agent de circulation†
signature:		Witnessed:	
(Person rendering the report)		Témoigné par:	
de l'agent établissant la fiche)			

NOTE: † All names will be written in block letters.

Tous les noms propres seront écrits en capitales d'imprimerie.

x Further details may be added on the reverse side.

Tous details supplémentaires pourront être indiqués au dos.

* French Officers had no Service No.

Les Officiers français n'ont pas de No Matricule.

NATO—UNCLASSIFIED

Figure 53. NATO standard offense report.

patched for certain traffic control or route reconnaissance, all military police patrols perform traffic control and route reconnaissance functions. Like TCP, the patrol gathers all available information.

(4) Performing intelligence functions as outlined in paragraph 120.

(5) Performing counter guerrilla operations.

(a) The patrol activities serve to deny routes of communication to the guerrillas.

- (b) The patrol, while performing its traffic control mission, is oriented to initiate, within its capabilities, offensive action against guerrillas.
 - (c) The mobility of the patrol allows it to aid other military police when under attack by a guerrilla element. Military police unit plans should provide for the assembly of military police patrols to provide unity of action against a guerrilla force.
 - (d) Motor patrols may act as flank elements or may be used to move to the rear of a guerrilla force during offensive operations (FM 31-16).
- (6) Deploying to man temporary check points or roadblocks (ch. 13).
 - (7) Functioning as a mobile straggler collection point. It is also a normal mission that mobile patrols, particularly those equipped with $\frac{3}{4}$ -ton vehicles, provide transportation of stragglers from a TCP to a straggler collecting point.
 - (8) Insuring that refugees use the roads assigned to them and do not use those roads assigned for military use.
 - (9) Serving as relief for other military police, and performing administrative functions such as resupply and ration distribution.
 - (10) Acting as escorts and providing physical and personnel security when so directed.
 - (11) Checking traffic signs and insuring that guide signs have not been changed by enemy or guerrilla forces to divert traffic into vulnerable areas.

130. Method of Patrolling

a. General. In determining patrol assignments the military police headquarters evaluates the task, applying the principles of METT outlined in paragraph 118.

b. Area Patrols.

- (1) *Unprogrammed area patrol.* Most patrol instructions prescribe an area that includes major roads with or without TCP. The mission of an unprogrammed area patrol does not specify an assigned route or a time schedule, but permits the patrol free

movement throughout its assigned area. Normally a requirement is placed on the patrol to coordinate with all other MP posts and activities within the area; however, coordination with adjoining patrols is not programmed or scheduled.

- (2) *Programmed area patrol.* The activities of the programmed area patrol are scheduled, planned and programmed in advance. Programming should include scheduling of time for main route patrolling, coordination with TCP and adjoining patrols, performing as a TCP when necessary and providing time for free movement. Programming must not prescribe a regular pattern.
- (3) *Combination patrols.* This is the most common method used in accomplishing the patrol task, since this allows flexibility of action. The usual method is to combine the unprogrammed area patrol technique with the programmed area patrol technique. This achieves a balance between control and freedom of action.

c. Route Patrol. This type patrol activity restricts the military police to a specific route which is constantly patrolled. This patrolling may be conducted on schedule or may be unscheduled. The main supply route (MSR) is usually the only route that will receive this type of patrolling. Normally, one of the following conditions require the use of this type of patrolling:

- (1) A lack of military police to establish necessary TCP on the route.
- (2) Circumstances or incidents that lead to congestion and other traffic problems. Included are: refugees on the route; limiting road factors (bridges, short defiles, etc.) or a high accident rate.
- (3) As a means of enforcing the requirements of highway regulation, necessity to insure that movements have proper authorization to use the road (Movement Credit).
- (4) As a part of the rear area security plan. Usually this is only employed as a part of a special operation.

CHAPTER 11

RECONNAISSANCE

131. General

a. There are two types of traffic reconnaissance: traffic control reconnaissance, and route reconnaissance. Traffic control reconnaissance is the gathering of information which will provide a base for the traffic control plan. Route reconnaissance is primarily a function of the Engineer who conducts reconnaissance to secure technical information, such as road construction, load capacities, and bridge restrictions. The military police will conduct route reconnaissance as an emergency measure when there are no engineers available. The route reconnaissance conducted by the military police is restricted to the minimum information necessary to determine the qualities of the road and is usually called a "hasty route reconnaissance" in comparison to the "detailed reconnaissance" performed by the engineers (para. 137).

b. The military police motor patrol is charged with the function of constantly conducting a traffic control reconnaissance. The patrol is also responsible to confirm the route condition. When a military police patrol is detailed to conduct a route reconnaissance it should be assigned as its primary duty.

c. Summaries of the results of both the traffic control reconnaissance and the route reconnaissance in their area of assignment should be available to all military police patrols and TCP.

132. Methods of Reconnaissance

a. *Ground Reconnaissance.* Reconnaissance should be made on the ground over the actual terrain to be traveled; this type reconnaissance provides for detailed examination of road features and limitations which is not obtainable by any other method. However, ground reconnaissance is time consuming, and it may be difficult for a reconnaissance group to move

over a route having a heavy flow of traffic or subject to enemy attack.

b. *Air Reconnaissance.* Air reconnaissance has certain advantages over ground reconnaissance in that the use of aircraft permits a rapid coverage of extensive areas and of specific places where traffic problems exist. The observer can move quickly to areas that need his attention and can switch rapidly from one road to another without interfering with, or being impeded by, surface activity. The helicopter is ideally suited for this type of reconnaissance. A disadvantage is the inability of the aircraft to travel the road to make a close examination of specific road features and limitations.

c. *Air-Ground Reconnaissance.* An air-ground reconnaissance combines the best features of both the ground and the air methods. Part of the team travels in a helicopter and part of the team travels in a surface vehicle.

- (1) The leader of the reconnaissance team, in a helicopter, goes ahead of the ground group to spot areas or situations that require detailed examination by the ground group. He also searches the area parallel to the route of advance for alternate routes and reconnoiters roads that cross or intersect the road traversed by the ground group. A survey of the surrounding area is accomplished as part of the counter guerrilla effort.
- (2) The effectiveness of the air-ground reconnaissance team depends mainly on effective radio communications. Should radio communications fail or be impossible because of security restrictions, the aircraft can land near the surface vehicle and the two groups can confer.

- (3) An added advantage of the air-ground method is that the two groups are mutually supported for security. Each group should be alert for, and should warn the other group of, any dangers on the route of advance. In some instances, one air reconnaissance group may coordinate and supervise several ground reconnaissance groups.

d. Map Reconnaissance. Maps and aerial photographs may help traffic control planning personnel to visualize the layout of an area and the relative locations of roads, bridges, key installations, and facilities. This method is also useful in making tentative traffic control plans prior to the time that an area can be entered by a reconnaissance team. Maps and overlays are used for recording road and traffic information to make it graphically available. In every case, the best and most up-to-date maps should be used in conjunction with the latest aerial photographs. Military police should not rely solely on the use of maps and aerial photographs as a traffic control reconnaissance when ground or air reconnaissance is possible.

133. Organization

a. When the military police are to perform reconnaissance the team should be organized similar to the type motor patrol discussed in paragraph 127.

b. In addition to the equipment normally found with a motor patrol the reconnaissance team should be equipped with the following:

- (1) Compass.
- (2) Measuring tape.
- (3) Sketch pads.
- (4) Colored pencils.
- (5) Overlay materials.
- (6) Detail maps and overlays of the area.

134. Briefing

The briefing of a reconnaissance team will follow the briefing outlined in paragraph 109. In addition the briefing will include the following:

a. When stating the mission, the exact purpose of the reconnaissance will be stated.

b. When the reconnaissance is to be conducted for a specific move, the briefing will

include information on the date/time of the move; the number, types, weights, and characteristics of vehicles involved; the organization of the movement; and tentative plans for its control.

c. The routes, to include possible alternate routes and areas to be reconnoitered.

d. Difficulties that the military police have encountered in the area as well as specific traffic problems.

e. The location of installations.

f. Coordination necessary with local police.

g. The amount of information to be gathered, when the reconnaissance must be completed, and how the report is to be submitted. Usually the report will be submitted in overlay form.

135. Traffic Control Reconnaissance

Normally a traffic control reconnaissance team will gather the following types of information:

a. Location and characteristics of road obstructions.

b. Road repair or construction.

c. Driving time and actual distance between various points.

d. Location, characteristics, and condition of potential alternate routes and bypass routes.

e. Location and characteristics of potential TCP and holding areas.

f. Location of potential ambush areas.

g. Location and characteristics of areas that may be used for defensive positions for both road users and military police traffic control personnel.

h. Location of and possible bypass for contaminated areas.

i. Information on the current traffic flow to include in general who is using the road, numbers and types of vehicles, and areas of congestion. An estimate as to the maximum traffic volume possible without congestion should be made. This will be expressed in estimated number of 2½-ton trucks passing a point during a 1-hour period of time. The point selected for making this estimate should be a

major intersection or the most restricted bridge or defile along the route.

j. Information as to current traffic control measures.

- (1) Location of traffic control personnel, periods of operation of control points, and mission of control points.
- (2) Location, condition, and effectiveness of traffic control devices and signs.

k. Locations of possible communication sites for the military police.

l. Location of military units and facilities in the area.

136. Traffic Control Reconnaissance Report

Based on information obtained by the team, the report should contain specific recommendations concerning the following:

- a.* Location of traffic control posts.
 - (1) The following items must be specified:
 - (a) TCP to be established pending the erection of signs.
 - (b) Periods of time that TCP should be operational.
 - (c) Temporary TCP necessary during a construction phase.
 - (d) TCP necessary to direct traffic around a contaminated area.
 - (e) The number of men to be assigned to a TCP team and items of special equipment needed.
 - (2) These recommendations are based on the following considerations:
 - (a) TCP are recommended only where absolutely necessary.
 - (b) Signs and other devices will be used in place of military police when possible.
 - (c) The use of a patrol to service this area should be evaluated.
 - (d) Military police will not be used as road guides.
 - (e) The goal of traffic control is maximum flow with minimum control.
- b.* Establishment of motor patrols.
 - (1) Size and equipment of the patrol.
 - (2) Areas and routes to be patrolled.
 - (3) Method of patrolling.
 - (4) Areas and points that require special patrol interest.

- (5) Points and areas where radio communication can be rated as excellent or poor.

c. Location of proposed signs and traffic control devices, including changes in current signs and control devices.

d. Location of potential alternate routes and roads; check points and roadblocks; turn-arounds and holding areas; and emergency vehicle services such as wrecker and repair services.

e. Changes to the traffic circulation plan. Such changes may be proposed even though this function is the responsibility of the headquarters controlling the area. A recommendation to change the traffic circulation plan should be considered as long range, and recommendations covered in *a* to *d* above should not be dependent on a change to the traffic circulation plan. Recommendations to change the traffic circulation plan may include:

- (1) Changing or restricting the flow of traffic. An example would be the establishment of a one-way traffic flow.
- (2) Increasing the control of a route by requiring a movement credit (para. 2) to use the road.
- (3) Rescheduling or rerouting traffic during specific times or in a given area.

137. Route Reconnaissance

a. Route reconnaissance conducted by the military police is restricted to information that can be gathered by observation and without special equipment or technical engineer training. Whenever possible, this type reconnaissance is used to confirm currently available information. Under normal conditions the engineer makes a reconnaissance when the army moves into an area. The military police unit usually schedules reconnaissance on a quarterly basis to insure that the information is current.

b. The route reconnaissance conducted by military police includes:

- (1) A traffic control reconnaissance.
- (2) Width of roads.
- (3) Types and conditions of road surfaces and shoulders.
- (4) Location, types, dimensions, and characteristics of limiting features.

The more common types are bridges, culverts, tunnels, overpasses and underpasses.

- (5) Location of grades with a rise of more than 6 meters in 100 meters (app. VI).
- (6) Location of curves with a radius of less than 45 meters (app. VI).
- (7) Location and/or conditions of bypasses for limiting features.

138. Report of Route Reconnaissance

The report of a route reconnaissance forwarded to higher headquarters will include appropriate recommendations concerning traffic control. In addition the report will include:

a. A route classification for each route (app. VIII).

b. A classification of each different segment of the route. When a factor changes, such as the road width or the surface material, the classification will change.

c. Whenever possible, a proposal for alternate routes and bypasses for limiting features.

139. Method of Recording Reconnaissance Information

a. Route and traffic control reconnaissances results are usually reported to the military police unit on an overlay (fig. 54). Military police units and installations are portrayed by the symbols shown in FM 21-30. Traffic control devices, signs and other items not represented in FM 21-30 will be shown by use of an overlay legend. Under this system, the locations or proposed locations of route signs are indicated by numbers which are explained in the legend.

b. Detailed information for route reconnaissance is contained in FM 5-36. A summary of symbols used to portray a route reconnaissance is contained in appendix VIII.

Figure 54. Example of route and traffic control reconnaissance overlay.

(Located in back of manual)

CHAPTER 12

ESCORTS

Section I. GENERAL

140. Introduction

a. Methods of military police escort performed in the theater of operations are similar to those performed in a post, camp, or station environment. The majority of the escorts performed in the theater of operations will be of a security nature. An area of heavy enemy or guerrilla activity will necessitate a large number of MP escorts.

b. Whenever possible, military personnel traveling in individual vehicles or convoys will provide their own security. When the convoy personnel supply their own security, the military police provide information to the convoy commander and aid when necessary.

141. Road Classification According to Enemy Action

In the theater of operations, roads and routes may be identified according to the estimated risks from enemy activities along the route. The most common classification system is the color code. (For details see FM 31-22.)

a. *Green Road.* A road generally free from enemy activity; military personnel normally

are permitted to travel unarmed on this type road.

b. *Yellow Road.* A road upon which there is a risk of enemy activity. Along this type road, the pattern of enemy activity will take the form of sniping at vehicles and hit-and-run attacks. In an area with guerrilla activity, the majority of roads and routes will be yellow. In addition to providing security the military police will also enforce the following procedures:

- (1) All military personnel traveling the road will be armed.
- (2) All military vehicles will carry a minimum of two men.
- (3) Vehicles should be required to be close enough to each other to render mutual assistance but not so close that a small ambush force can attack all vehicles. This is normally accomplished by check points or TCP forming individual vehicles into provisional convoys.

c. *Red Road.* A road lying within the combat area or subjected to such enemy activity that it requires offensive action by combat troops to reduce the enemy.

Section II. MILITARY POLICE SECURITY ESCORT

142. Planning

a. Detailed planning is accomplished by the military police unit prior to providing a security escort.

- (1) A reconnaissance is completed on the route to be used and possible alternate routes, as early as possible. Plans to deceive the enemy are prepared by the MP unit (FM 31-16).

- (2) An estimate of the situation is made by the military police. This is made after an analysis of enemy activity in the area.
- (3) Orders are prepared using the format outlined in paragraph 109. When possible these orders will be written.
- (4) Time permitting, all personnel will rehearse their duties.

b. Military police security escort is not normally provided for a troop unit, but is ordinarily restricted to VIP (very important persons) and classified material or supplies. The senior military policeman is the escort commander and is responsible for the security of the escorted personnel and equipment. With this responsibility he has the authority to direct the security operations. He is provided with a light mobile vehicle, such as the $\frac{1}{4}$ -ton truck, with simultaneous radio communication on two frequencies and armed with an automatic weapon.

143. Organization and Equipment of a Maximum Security Escort

a. Provision is made for the passage of command in the event the commander becomes a casualty. A team leader is appointed for each military police team which is formed for each MP vehicle in the escort.

b. The escort is divided into a lead element, a main body and an attacking element. Movements in excess of 8 escorted vehicles should be

divided into sections. The section is made up of both military police teams and escorted vehicles with the senior military police team leader acting as the section leader.

- (1) The escort lead is a reconnaissance element and will attempt to detect the enemy and prematurely trigger any enemy attack. The lead does not usually exceed three light vehicles. The first vehicle should have a cutting or deflecting bar to counter barrier cables or wires stretched across a road (fig. 55) and should be sandbagged to protect against mines. When the enemy has been employing mines, the lead may have an engineer mine detecting element attached to it. The lead element should precede the main body by 2 to 3 minutes so as to prevent a simultaneous attack on both the lead element and main body. However, an excessive time gap between the lead and main body provides the enemy with the capability of blocking the road after the lead has passed.



Figure 55. Example of a $\frac{1}{4}$ -ton vehicle with a deflecting bar.



Figure 56. Example of a $\frac{3}{4}$ -ton vehicle transporting escort personnel.

- (2) The main body is a mixture of the escorted vehicles and the military police.
- (a) The first vehicle should be a military police vehicle.
 - (b) The ideal ratio for maximum security of the main body is one military police team per two vehicles, $2\frac{1}{2}$ -ton or larger, or four vehicles, $\frac{3}{4}$ -ton or smaller.
 - (c) For security reasons, vehicles carrying personnel must not be overloaded. An example is that no more than 6 persons including the driver should be carried in a $\frac{3}{4}$ -ton truck.
 - (d) Security personnel are assigned individual areas of observation, each covering 90° from the center of the road. In addition to individual weapons military police personnel are armed with fragmentation and phosphorus grenades.
 - (e) Vehicles transporting escort personnel should have—
 1. The tarpaulins and bows removed.
 2. The tail gates removed or placed in a horizontal position.
 3. A single row of sandbags stacked five high on the sides of $\frac{3}{4}$ -ton and $2\frac{1}{2}$ -ton vehicles.
 - (f) All radios should be on the same frequency and on receive. Alternate signal means, such as flares or smoke grenades, will be available with each vehicle.
 - (g) In lieu of canvas on vehicles $\frac{3}{4}$ -ton and larger, chicken wire or other similar material will be used to protect against thrown objects such as grenades.
- (3) The attacking element follows the main body by approximately 3 minutes. It is composed of the main fighting element of the escort.
- (a) This element should be equipped with a preponderance of automatic crew-served weapons.
 - (b) Army vehicles should be attached to this element.

144. Military Police Security Escort (Light)

a. The principles outlined in the preceding paragraphs are applicable for light security escorts, as modified by the number of personnel and amount and type equipment available. In a situation where there is a limited number of military police the following modification normally applies:

- (1) The lead is made up from escorted vehicles.

- (2) Only one military police vehicle will accompany the main body.
- (3) The military police escort is organized into the attacking force.

b. If the enemy attacks only the attacking element, the lead and main body stop, establish security for the convoy, and then organize an attack to relieve the element under enemy attack.

c. Members of the convoy will be armed and briefed to assume those functions performed by a maximum security escort.

145. Escort of Special Weapons

a. Military police escorts are provided for security of special weapons. The primary mission is to protect the weapon and classified material from being destroyed or becoming available to unauthorized persons.

b. When a nuclear accident or incident occurs, in addition to security, the military police provide traffic control. (For details on nuclear accident or incidents, see FM 3-15.)

146. Action During an Attack

a. At the outset of any enemy attack, immediate and positive action is taken to neutralize the enemy and gain the offensive.

b. Vehicles should not be stopped but should clear the attack area. Vehicles that have not entered the area under attack will stop outside the area.

c. Security personnel under attack will immediately bring fire to bear on the enemy or his suspected position.

d. Personnel who have cleared the enemy attack position will detruck and, if possible, establish defensive positions as a base of fire.

e. Personnel in vehicles that are stopped or disabled in the attack area will dismount and form a base of fire. They also place pressure on the enemy by bringing a grenade attack to bear on him. Armored vehicles may be brought into the attack area to serve as a base of fire.

f. The attack element will immediately launch an attack on the enemy. Tactics to be employed are generally small unit tactics. The attack element must coordinate its movement by signals or radio. An attack should normally be made from only one direction so as to prevent an inter-unit clash.

g. The appropriate headquarters will be informed by radio of all enemy action as rapidly as possible.

CHAPTER 13

SPECIAL SITUATION CONTROLS

Section I. DEFILES

147. Definition

For traffic purposes a defile is defined as a natural feature, or a man-made structure or obstacle which restricts the flow to one-way traffic at a given time. Examples of a defile would include a damaged stretch of road, a narrow bridge or causeway, a path through a woods or narrow valley, or a street on which structures restrict movements to one-way traffic.

148. General Principles

The principles of traffic control at construction sites and detours (ch. 7) are valid with modifications for the theater of operations. Because movement is restricted, a defile offers the enemy an ideal target for the maximum disruption of military operations. Every effort must be made to pass all movements through the defile in the shortest possible time and to insure that any necessary concentration of troops and vehicles are effected away from the immediate vicinity of a defile. Traffic control in the vicinity of a defile must be absolute; direction of the traffic control is vested in the senior military policeman at the defile who must have an intimate knowledge of the area and conditions in the defile.

149. Operation of a Defile

a. All control techniques outlined in chapter 7, may be used at a defile; however, the most common technique is the use of a military policeman at each end of the defile with a motor patrol circulating through the defile and the surrounding area.

b. Within the limits of security, maximum use is made of signs to reduce to the minimum the

requirements for military police personnel (para. 98 and 99).

c. Holding areas as described in paragraph 121 will be established at each end of a defile. During periods of enemy air superiority or probable nuclear attack, a series of holding areas may be established from 2 to 3 km from the defile.

d. Each military police position must be developed to provide for defense. The number of security positions will be based on the requirements and military police personnel available. The senior military policeman will make a detailed reconnaissance of the area and an estimate of the situation using METT. Following this action a traffic control and security plan is developed. This plan is constantly examined to uncover areas for improvement.

e. Controls used or prepared for use at a defile will include at least two of the following independent techniques:

- (1) Visual—the use of military police to observe the entire defile.
- (2) Telephones should be used whenever possible between the ends of the defile and the turnouts. Defile control frequently generates a large volume of communication which, if radio were used exclusively, would become a source of intelligence to the enemy and would overload the military police radio net.
- (3) Flag method (para. 100).
- (4) Rider method (para. 100).
- (5) Lead and/or follow method (para. 100).
- (6) Radio located at the ends and all turnouts in the defile.

150. Equipment

a. A means must be available to the military police to clear the defile of disabled vehicles and minor obstacles. If possible, the military police unit will arrange for the use of a wrecker.

When circumstances do not permit the use of a wrecker, or if none is available, the military police must be prepared to utilize field expedients (FM 20-22).

b. A detailed list of equipment needed for a defile operation is shown in appendix IV.

Section II. CHECKPOINTS

151. General

Military police establish check points, when necessary or directed, to insure proper use of routes and to check for proper use of vehicles and inspect their cargoes.

152. Location of Checkpoints

Checkpoints are normally established at—

a. Main entrances to a reserved route or a route that requires a "movement credit."

b. Major unit rear boundaries.

c. Locations in an area where the local population is supporting enemy activity

d. Locations in an area where there is extensive blackmarket operation.

153. Operation of a Checkpoint

a. A check point with a circulation control or antiblackmarket mission is established at a location where there is little chance of approaching drivers making a U-turn or taking other action to avoid the checkpoint. A position beyond sharp curves has the advantage of denying a view of the checkpoint to approaching drivers (fig. 57).

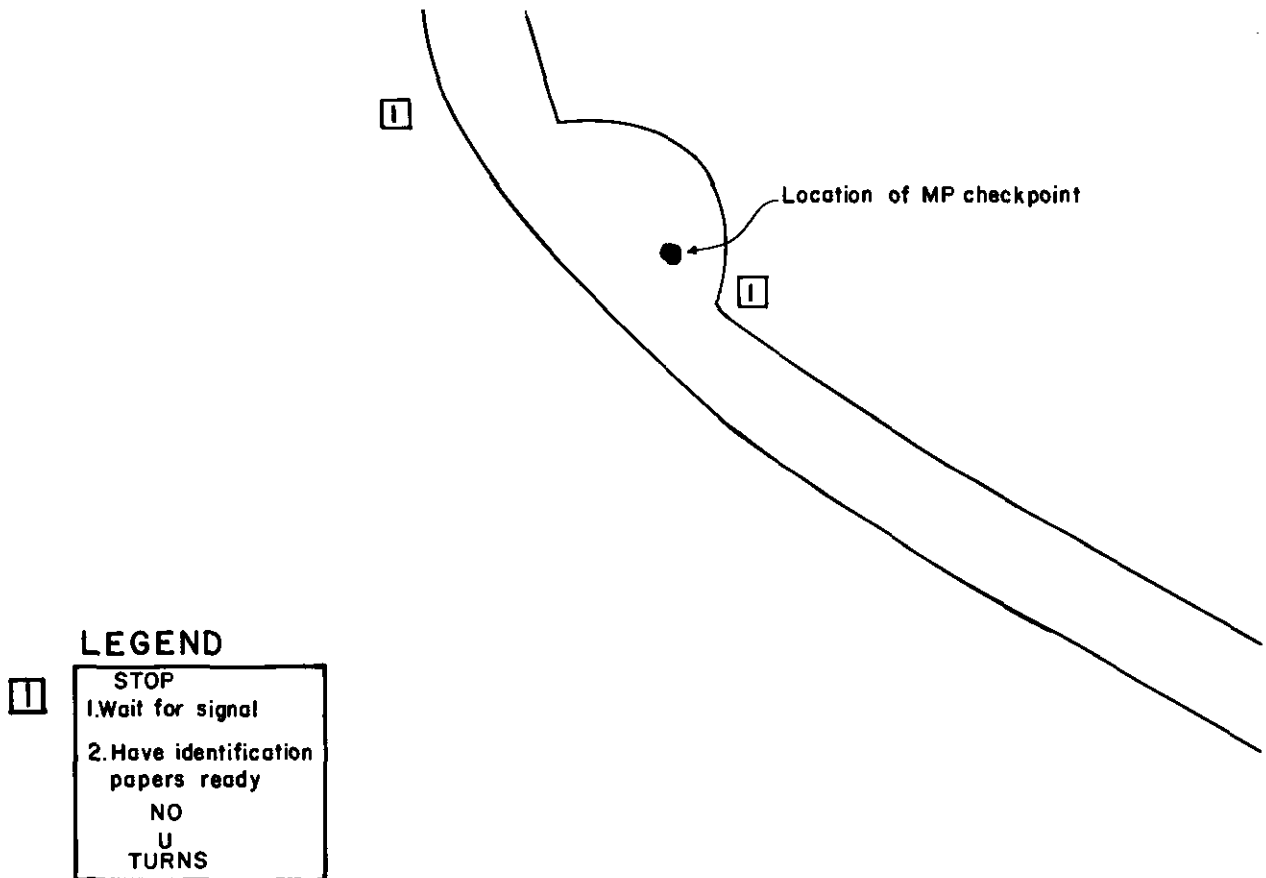


Figure 57. Location of a check point with a primary antiblackmarket mission.

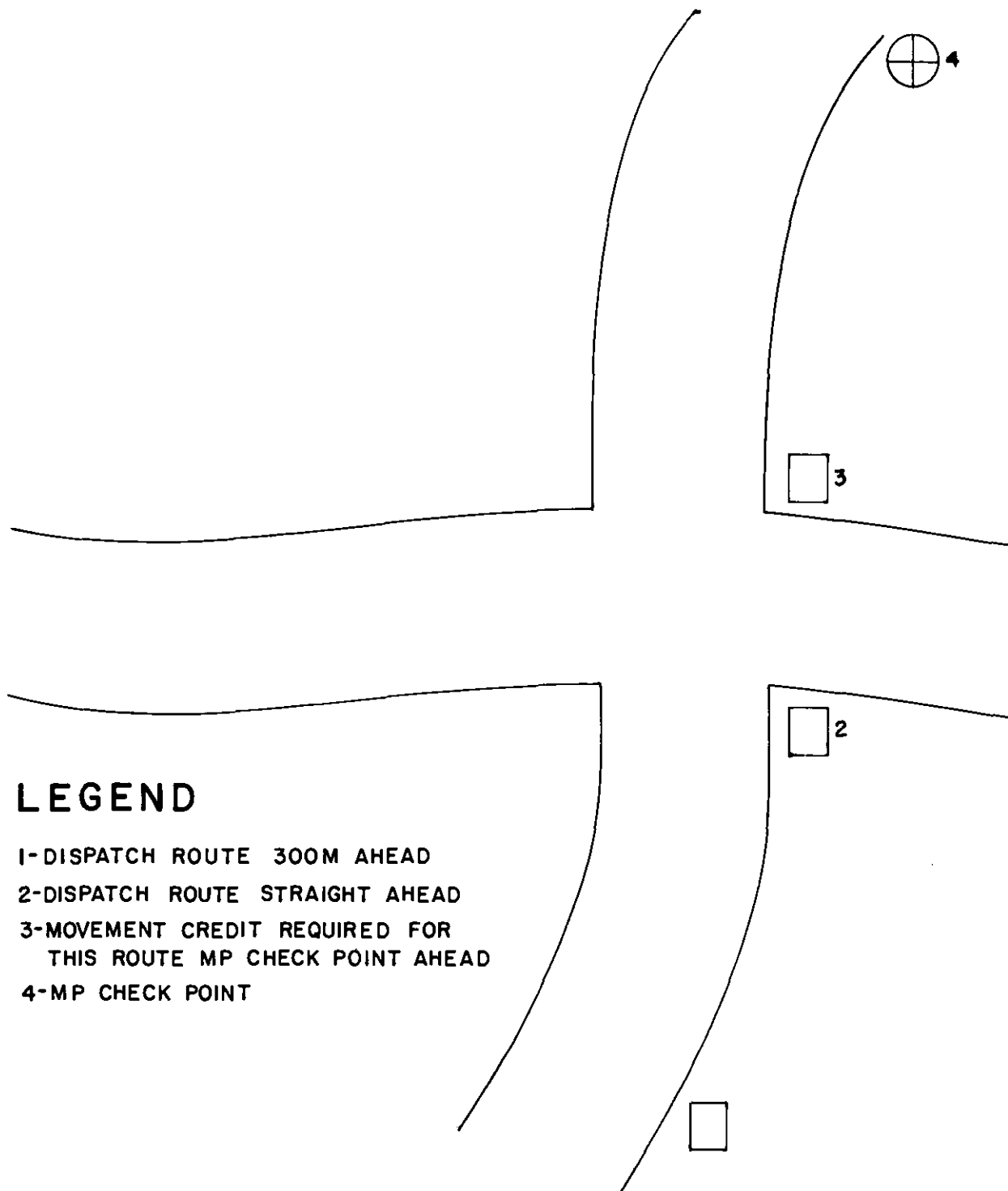


Figure 58. Example of signing a checkpoint.

b. A checkpoint with the mission of insuring proper road use is established at a location where vehicles cannot bypass it and still use the road. For this type of checkpoint every ef-

fort is made to inform the road users of the existence of the checkpoint thus encouraging voluntary compliance with the requirements of highway regulation (fig. 58).

c. The location of the checkpoint must provide an area where vehicles can be moved off the road when necessary.

d. Approach lanes should be outlined with traffic cones or wooden stakes.

e. Signs should be posted which provide instructions to the road user as to requirements at the checkpoint.

f. A barrier, such as a wooden pole or gate, should be available to insure that vehicles stop at the designated place.

g. A military police patrol vehicle must be available for pursuit of vehicles or individuals who fail to stop at the checkpoint.

h. Security must be stressed in organizing a checkpoint. The principles for TCP security are applicable to checkpoints.

i. Equipment for checkpoints is listed in appendix IV.

j. The military policeman should be constantly alert for and report new methods that are used by persons attempting to bypass the checkpoint or conceal unauthorized items.

Section III. ROADBLOCKS

154. General

In the theater of operations roadblocks are an extension of checkpoints. While the general operation of a roadblock is the same as that of a checkpoint, the emphasis is on surprise. Roadblocks are temporary and are established as a part of an emergency plan or for some special purpose.

155. Operations of a Roadblock

a. Roadblocks are normally established where there is sufficient space to park vehicles and assemble personnel under guard so that searches and interrogations can be conducted. Searches conducted must be thorough and military police personnel must be briefed on the object of the search and those techniques currently being used to conceal items from military police detection.

b. The area used is organized in such manner as to prevent persons from avoiding the roadblock.

(1) Obstacles, portable but sturdy enough to stop a vehicle, are placed on the roadway to channelize traffic.

(a) Iron bars.

(b) Logs—fallen trees.

(c) Sandbags.

(d) 55-gallon drums filled with sand.

(e) Ditches.

(f) Vehicles (if other objects are not available).

(2) The shoulders of the road must be such that vehicles cannot bypass the roadblock or the barrier system must be extended to provide denial.

c. Channelization of personnel, on foot, is established by using an open area with appropriate warning signs, field of fire, concertina, or

other barbed wire.

d. Sufficient positions are established at the checkpoint to—

(1) Provide security.

(2) Prevent vehicles and personnel from turning around before reaching the roadblock.

(a) This position is ideally located at a curve in the road where personnel could see the roadblock for the first time. If this is not possible, then this position should be approximately 750 meters on each side of the roadblock.

(b) Personnel assigned to this duty should be well concealed and equipped with automatic weapons and grenades.

(c) A portable means to block vehicle movement should be available at this position.

1. Boards covered with 10-penny nails half exposed that can be dropped or pulled across the road will slow vehicles with pneumatic tires.

2. A wire lying across the road may be elevated and pulled tight when a vehicle attempts to run the roadblock. While this is effective, it may also cause injuries.

e. Communication must be maintained with the military police unit and with patrols operating in the vicinity of the roadblock. Internal communication between the different posts and activities of a roadblock should be primarily by use of wire or signals with a radio backup.

f. A type of roadblock is shown in figure 59.

g. Equipment necessary for a roadblock is outlined in appendix IV.

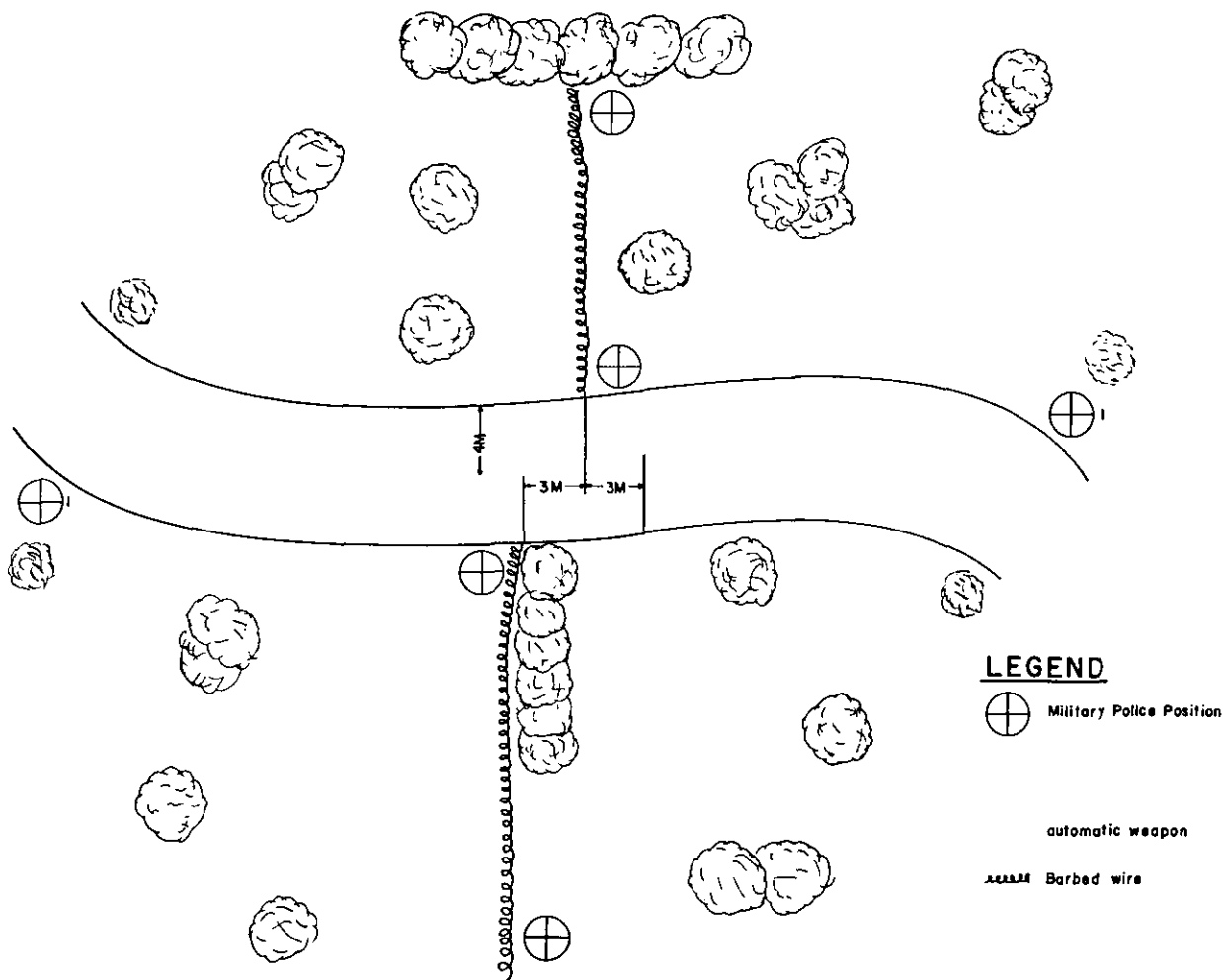


Figure 59. Example of a type roadblock.

Section IV. BRIDGES AND OTHER CROSSING MEANS

156. General

Movement may be seriously disrupted by enemy attacks on bridges and crossings. An unfordable stream or the lack of a bypass, if a bridge is rendered useless, increases the advantage to the enemy. Site security and bridge load limit considerations require military police action.

157. Functions at Bridges and Other Crossing Means

a. Military police traffic control functions at bridges and other crossing means include the enforcement of traffic rules and regulations, including speed and vehicle interval limits; the

enforcement of crossing limitations; and the control of traffic during special crossings.

b. The military police also insure that traffic flows to the crossing site without congestion. When necessary, holding areas are established on access roads approximately 1 to 5 km from the crossing site (fig. 60).

c. Under normal operating conditions military police, as a part of traffic control, provide security for the crossing site, although in some cases combat troops will be provided for this purpose.

158. Classification

a. Classification is the military method of evaluating bridges and crossings means as to

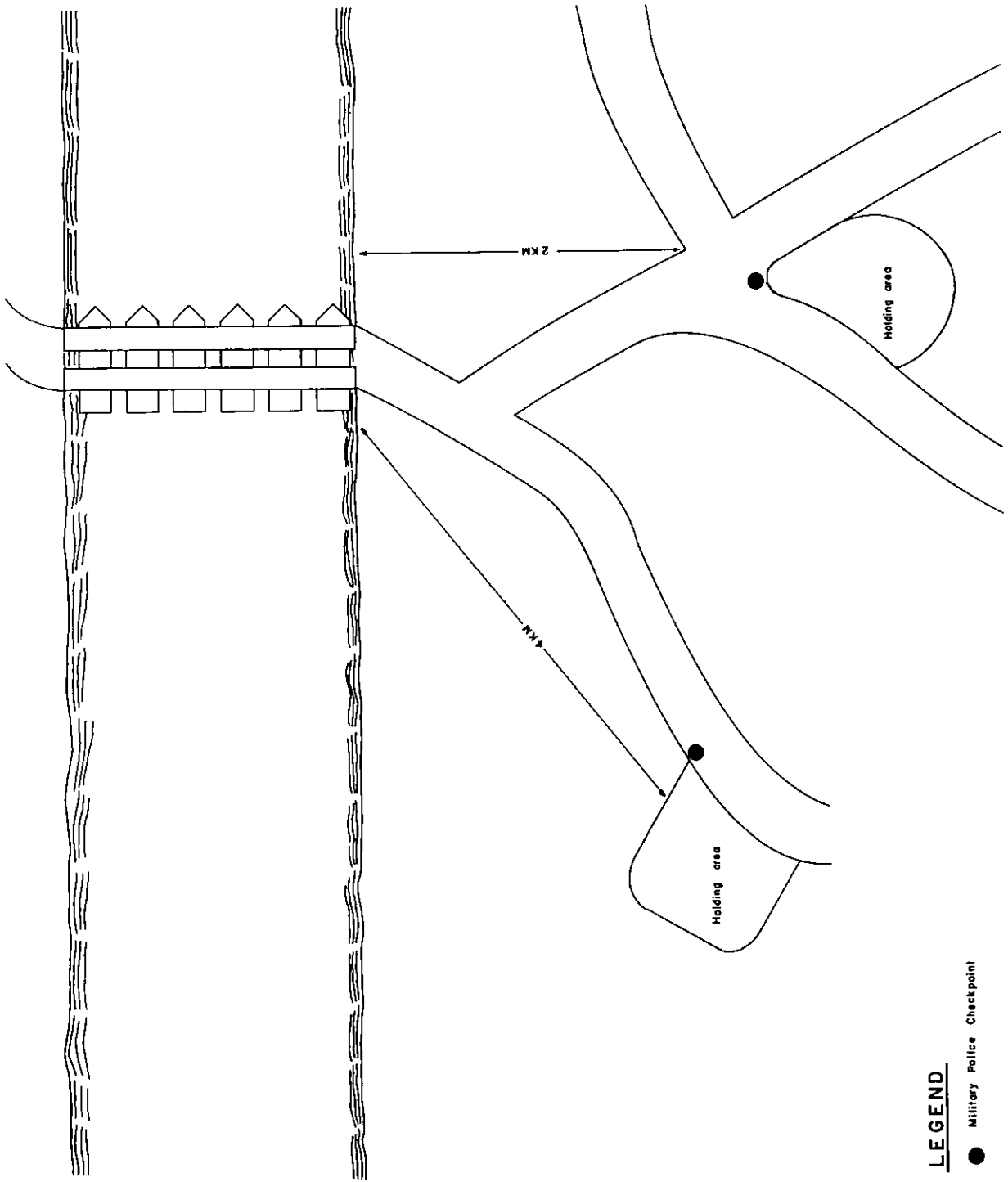


Figure 60. Location of holding areas.

their safe load-carrying capacity under normal crossing conditions. This classification is made by the engineers (FM 5-36).

b. The classification is represented by a class number. This number does not indicate weight, but rather the effect that a vehicle has on a bridge or crossing means. The class number is shown on signs erected by the engineer at the beginning of each bridge or crossing site (fig. 61).

c. Classification numbers assigned to vehicles are whole numbers ranging from 4 through

150. Figure 62 indicates the methods that are used to portray vehicle classification.

159. Types of Bridge Crossings

There are two types of crossings:

a. *Normal Crossings.* Normal crossings may be made whenever the vehicle class number is equal to or less than the bridge class number. Normal convoy discipline must be imposed on the vehicles making a normal crossing. A minimum spacing of 27 meters and a maximum speed of 25 miles per hour are the main limita-

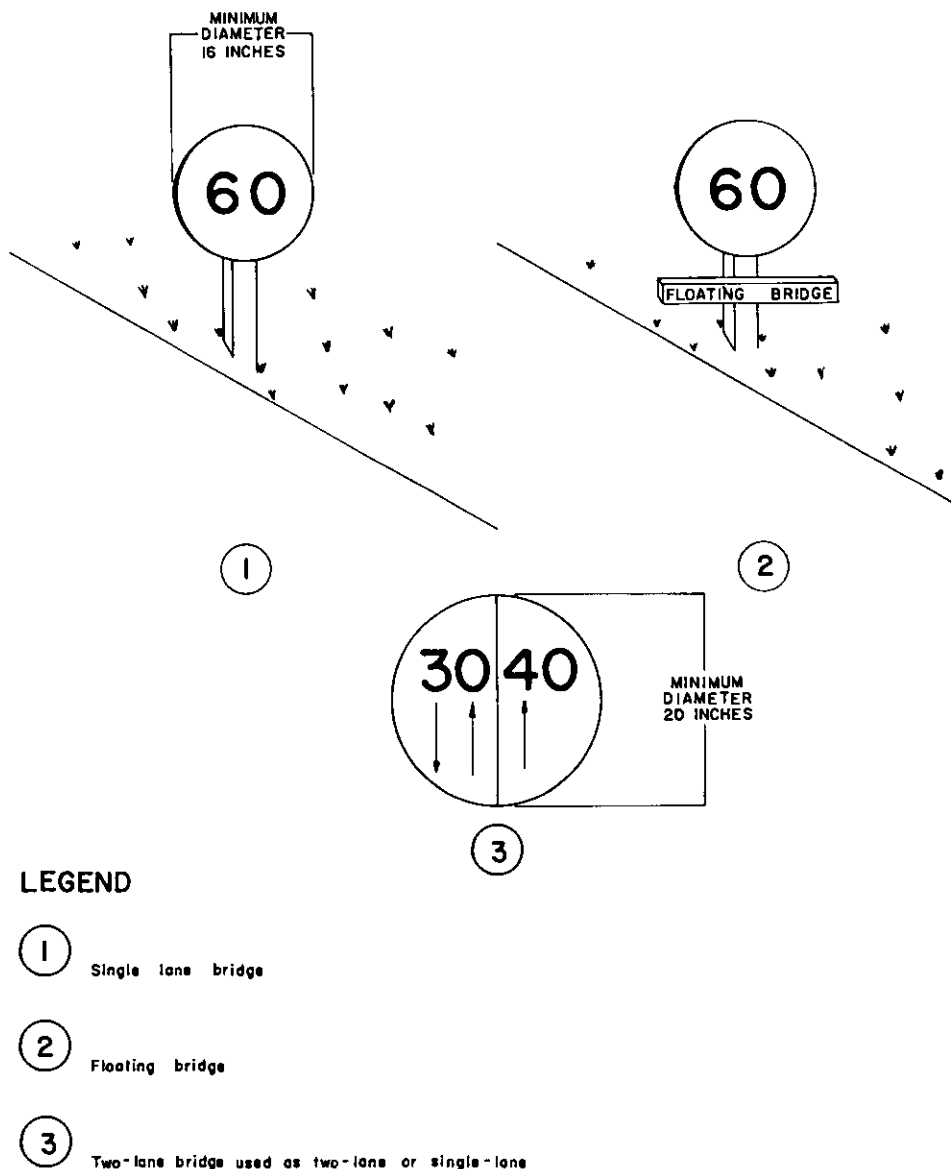
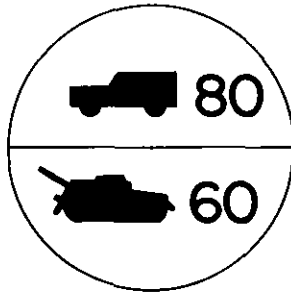
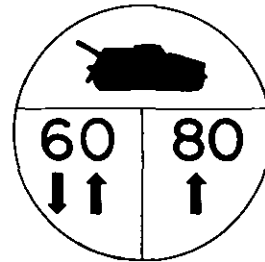
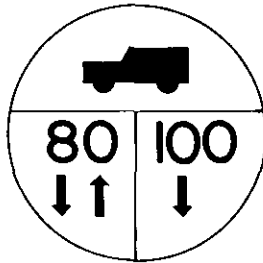


Figure 61. Example of bridge classification signs.



1 Limiting wheeled vehicle class and limiting tracked vehicle class



2 Combination of dual class and two-way bridge class signs

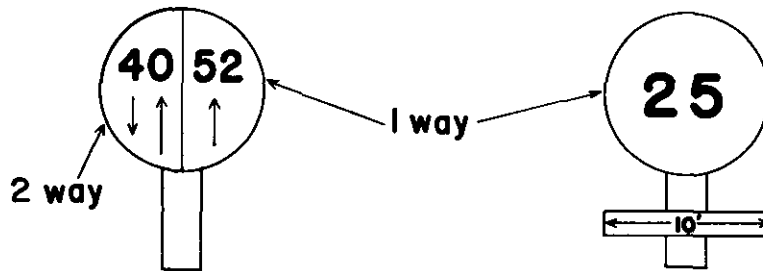


Figure 61—Continued.

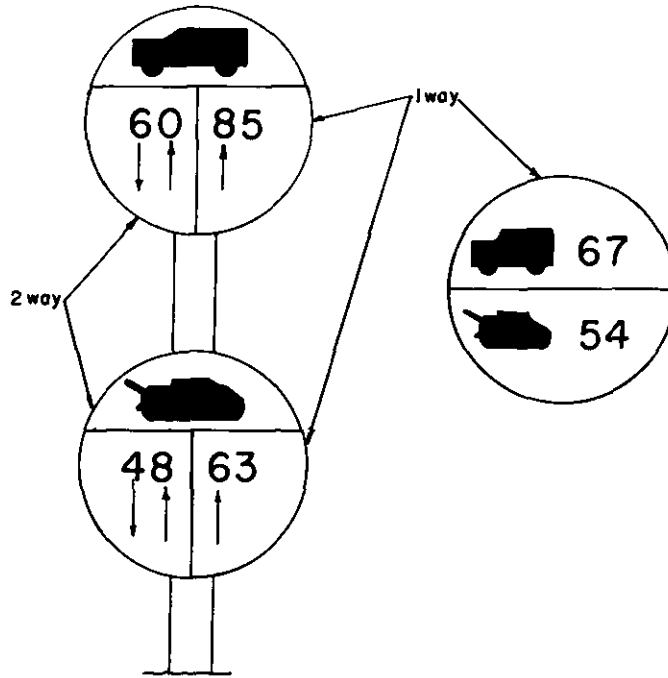
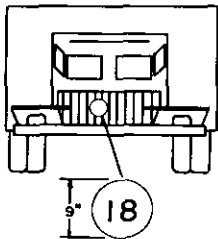
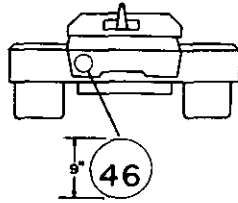


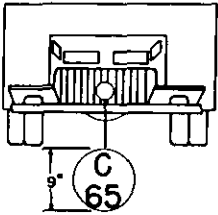
Figure 61—Continued.



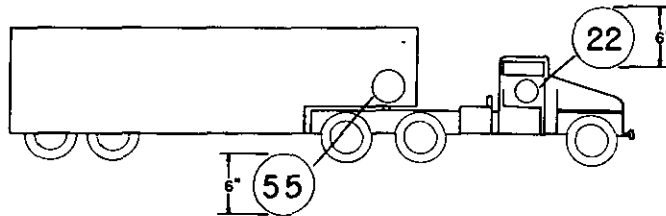
WHEELED VEHICLES



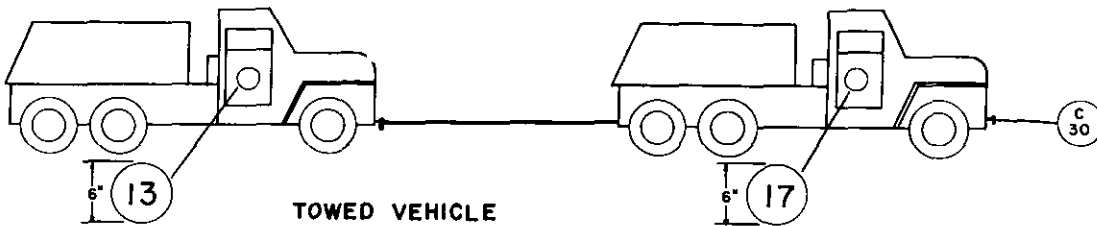
TRACKED VEHICLES



COMBINATION CLASS



COMBINATION VEHICLE



TOWED VEHICLE

Temporary sign

Figure 62. Example of methods of portraying vehicle classification.

FLOAT BRIDGES

1 Type of bridge	2 Load classes ²															3 Traffic capacity and vehicular distance for safe crossing in daylight (except as otherwise noted) ³			
	Safe crossing (posted capacity) ⁴					Caution crossing ⁴					Risk crossing ⁵								
	Stream velocities in meters per second (mps)																		
	1	1.6	2.3	2.6	3	3.6	1	1.6	2.3	2.6	3	3.6	1	1.6	2.3		2.6	3	3.6
2 Footbridge, aluminum			Safe			--	--	--	--	--	--	--	--	--	--	--	--	Day: 75 men per min Night: 40 men per min at 2-pace distance ⁷	
3 Light tactical bridges	16	16	13	11	8	2	18	18	15	12	9	3	21	21	17	14	11	5	400 vehicles per hr 30 meters distance between vehicles
4 M4T6 ¹ float bridge	Normal	45	40	35	30	25	60	58	54	49	45	35	68	66	62	59	54	43	400 vehicles per hr
	Reinforced	75	70	65	55	27	80	80	79	73	66	43	90	90	90	87	81	59	30 meters distance between vehicles
5 Class 60 floating bridge	Normal	60	55	50	45	22	65	62	56	52	45	34	75	72	67	62	57	46	400 vehicles per hr 30 meters distance between vehicles
	Reinforced	65	65	55	50	25	70	67	61	56	49	37	79	77	72	67	62	50	400 vehicles per hr 30 meters distance between vehicles
6 M4 floating bridge (limited standard)	Normal ²	60	60	45	45	30	18	65	58	52	44	29	72	68	61	58	53	37	
	Reinforced ³	95	95	75	60	45	24	105	100	88	75	62	85	105	101	88	74	45	
7 Amphibious Mobile assault bridge	Normal	60	60	55	50	25	65	65	60	55	50	35	73	73	67	65	60	45	400 vehicles per hr 30 meters distance between vehicles
	Reinforced	65	65	60	55	30	70	70	65	60	55	40	78	78	72	70	65	50	

¹ Ratings based on 18 balk between curbs (166½ in) in 22 balk wide superstructure.
² Based on abutments at levels within 12-in of floating bridge deck level.
³ Vehicle anywhere on bridge deck between curbs. Speeds up to 40 kph permitted, but 24 kph recommended. Vehicle spacing, 30 meters.
⁴ Center of vehicle within 12 in of bridge centerline. Maximum spd 13 kph. Vehicle spacing 50 meters. No stopping, accelerating, or gear shifting.
⁵ Ratings based on use of double deck end span 100 percent reinforced floating sec & 20 balk between curbs (185 in) in 24 balk wide superstructure.
⁶ Traffic capacities are for all traffic moving forward or rearward.
⁷ Reduce capacity 20 percent for currents of 3 to 3.6 mps.
⁸ Ratings based on use of reinforcing ponton in end span and 1 balk between curbs (166½ in.) in 22 balk wide superstructure.
⁹ 60-ton tanks having tread widths of 143 inch or more may cross safely up to 2.3 mps. KEY
 Class for Wheeled & Tracked Vehicles.
 Class for Wheeled Vehicles.
 Class for Tracked Vehicles.

Figure 63. Float bridge load classes for various crossings.

tions imposed during a normal crossing. These are two types of normal crossings: normal one-way, and normal two-way.

- (1) Normal one-way. This type of crossing is permitted when the vehicle class number is equal to or less than the number posted on a single-lane bridge or the one-way class number of a two-lane bridge. If a one-way crossing is made on a two-lane bridge, the vehicle should be driven down the center of the bridge.
- (2) Normal two-way. The type of crossing is permitted when the vehicle class number is equal to or less than the two-way class number of a multilane bridge. Two-way traffic may be maintained with this type of crossing.

b. Special Crossings. Special crossings are classified as caution crossings and risk crossings. A special crossing is one in which the bridge class number is less than that of the vehicle. A special crossing may be authorized by military authority under exceptional operating conditions or by local civil authorities if appropriate.

- (1) A caution crossing is a bridge crossing where vehicles with a classification up to 25 percent above the posted bridge loadings are allowed to proceed cautiously across the span. A caution class number is obtained by multiplying the normal crossing class number of either a single lane or multilane nonstandard military bridge by 1.25. For standard prefabricated bridges, the vehicle class number must not exceed the published caution bridge class number. During a caution crossing, the vehicle remains on the center line of the bridge, maintains a 45-meter distance from the vehicle in front, does not exceed a speed limit of 8 miles per hour, does not stop, is not accelerated, and does not have its gears shifted on the bridge.
- (2) A risk crossing may be made only on prefabricated fixed or floating bridges. Risk crossings may be made only in the gravest emergencies where excessive losses will otherwise result. The

vehicle will remain on the center line of the bridge, not exceed a speed limit of 3 miles per hour, be the only vehicle on the span, not stop, not be accelerated, and not have its gears shifted. Tanks, on risk crossings, must be steered by using their clutches only. Risk crossings are permitted only when the vehicle class number does not exceed the risk class for the bridge (fig. 63).

160. Fords and Other Crossings

a. A ford is a shallow place in a stream or other body of water where the physical characteristics of the bottom and the approaches to the stream or other body of water permit the passage of personnel and vehicles. Fords are classified according to their crossing potential for foot, wheeled, and tracked movements. Military police on traffic control duty at a ford should be fully briefed on the crossing potential and the trafficability characteristics of the ford. For details, see FM 5-36 and appendix IX.

b. Other crossing means include tunnels and ferries. For details, see FM 5-36.

161. Crossing Site Operations

a. A type employment of military police at a crossing site is shown in figure 64.

b. Activities of the military police are directed by an officer or noncommissioned officer who is located close to the crossing site. When an engineer element is present the military policeman in charge should be located with the engineer in charge.

c. Instructions for the military police at the site will include information concerning priority for use of the crossing and limitations on other than normal crossing.

d. Communications are organized to connect all military police positions. Telephones are used as the principal means of communication, supported by radio and connecting motor patrols, if used.

e. Permanent signs are erected by the engineers. The temporary signs on bridges, to include bridge class, are also the engineers' responsibility.

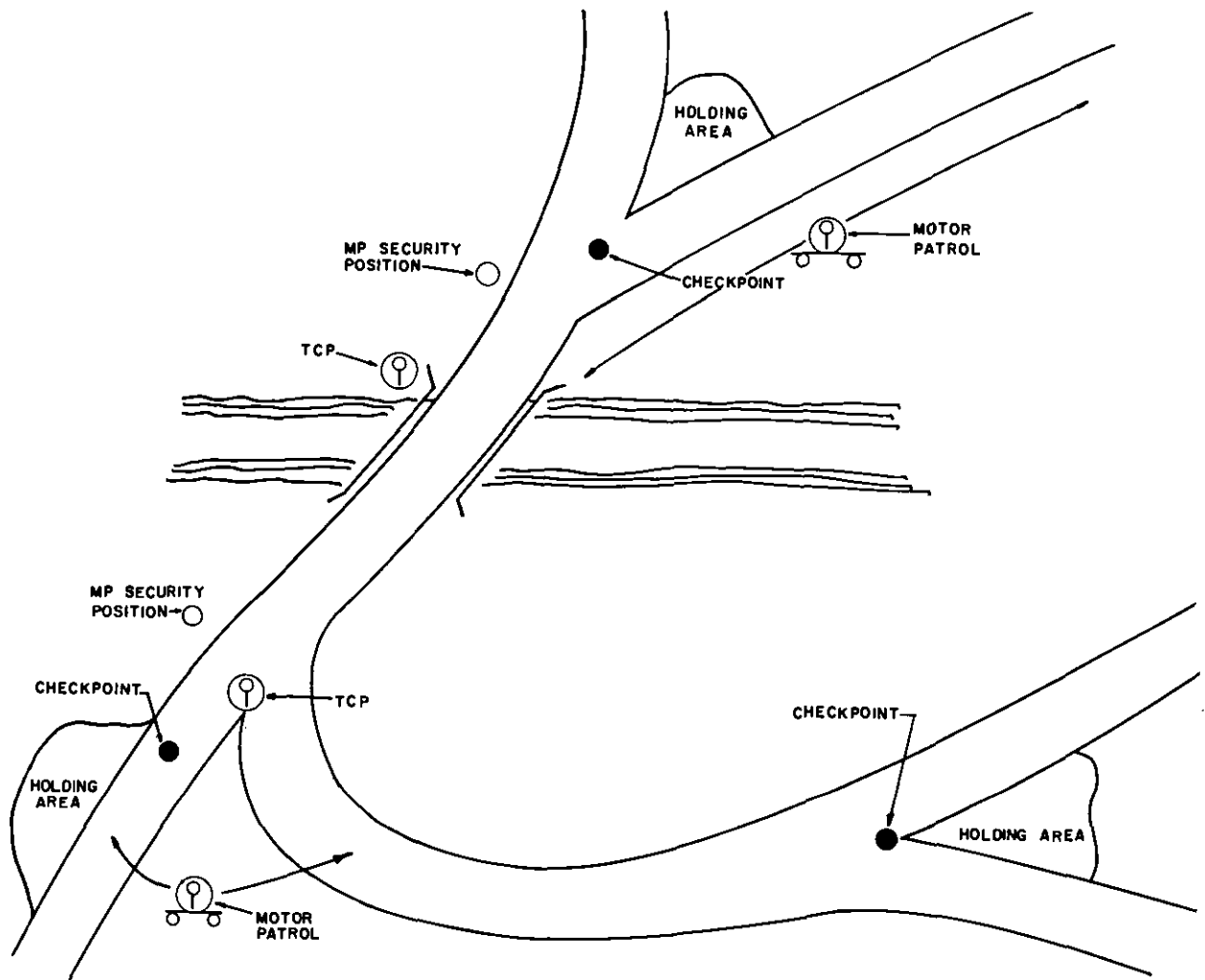


Figure 64. Example of a type employment of military police at a crossing site.

f. Other temporary signs, to include direction signs and those in holding areas, are emplaced by the military police.

g. The military police, in cooperation with the civil affairs unit, insure that refugees do not create congestion at crossing sites. It may

be necessary to establish positions along trails and paths to insure that refugees do not enter areas that are denied to them.

h. For crossing site equipment, see appendix IV.

Section V. DISMOUNT POINT

162. General

Military police providing security for a headquarters will establish a dismount point at the main entrance to the headquarters. This position provides traffic control, enforces vehicle parking and use within the headquarters area, and serves as a security post.

163. Functions at Dismount Point

a. To direct traffic in and out at the main entrance to a headquarters, and to enforce light restrictions.

b. To insure that only authorized vehicles enter the headquarters area.

c. To provide direction and supervision for parking areas outside the headquarters area.

d. To serve as a strong point for perimeter security of the headquarters.

e. To provide information on request to authorized personnel as to the location of installations in the headquarters area.

164. Organization of a Type Dismount Point

a. A type dismount point is shown in figure 65.

b. The dismount point will be divided into three functional portions:

- (1) Traffic control at the intersection of the main road and the access road to the headquarters. The military policeman at this point performs the same function as at any TCP and in addition

insures that only authorized vehicles enter the access road.

- (2) Traffic control at the parking area to insure maximum effective utilization of the area.

- (3) Security position at the main entrance to the headquarters area. This position is organized to offer protection to the other military police on the dismount point as well as perimeter security. Military police at this location insure that only authorized personnel enter the headquarters area on the roadway.

c. The principal communication means for a dismount point is visual, supported by telephones. The dismount point is integrated into the communication system of the unit providing security to the headquarters. For a detailed list of equipment for a dismount point, see appendix IV.

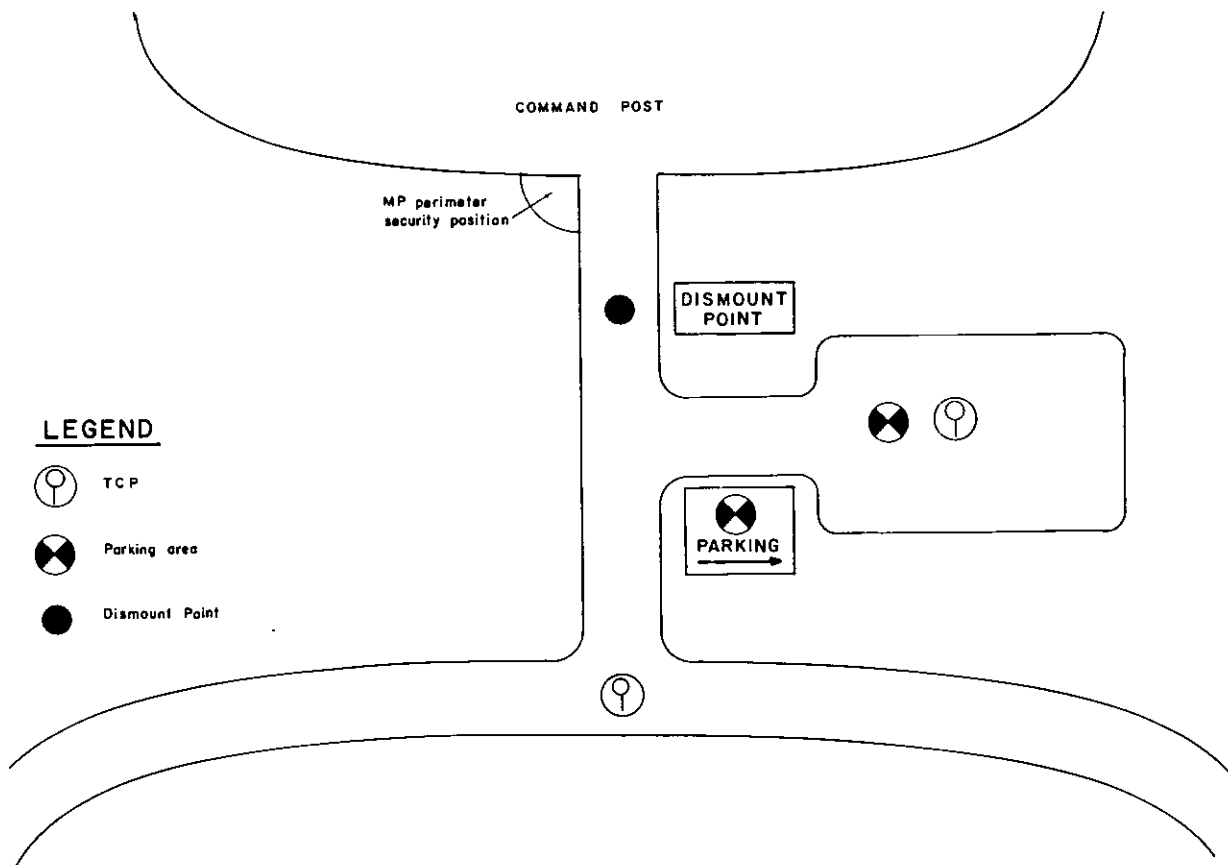


Figure 65. Example of a type dismount point.

CHAPTER 14

SPECIAL OPERATIONS

Section I. RIVER CROSSING

165. General

A river crossing is an offensive operation to overcome the action of the enemy and the effect of the river as a barrier. River crossing operations require absolute control and maximum security. The military police provide the commander with a means to control traffic involved in the operation. The military police personnel engaged in this type operation will be located in three areas, which will modify normal traffic control functions. These areas are the crossing area, the near side to the rear of the crossing area, and the far side (fig. 66). (For details, see FM 31-60.)

166. Traffic Control at River Crossings

a. Military police on traffic control duties at river crossings will insure that—

- (1) Only authorized movements take place.
- (2) Movement that is authorized is controlled to insure complete compliance with orders and regulations.
- (3) All vehicles clear the Engineer Regulating Points. An Engineer Regulating Point (ERP) is a location where engineer personnel supervise traffic prepared to cross to insure compliance with the technical requirements of the available crossing means.
- (4) Priorities will be honored.

b. Plans will be formulated to divert traffic in emergencies. These plans will be understood by all military police.

c. Although control of military police will be decentralized by area (para. 168) the entire military police effort must be fully coordinated.

d. Prior to the assault military police will rely on telephones. After the assault has begun

and radio silence has been lifted, radio communication will be used.

167. The Near Side

The near side to the rear of the crossing area (fig. 66) is the area from the division rear boundary to the traffic regulating line (*a* below). The objective of traffic control in this area is to provide an orderly continuous movement to the crossing areas. Special traffic control procedures or control measures are listed below:

a. A traffic regulating line is selected for each phase of the river-crossing operation and indicates the forward limit of responsibility for traffic regulation and control as exercised by the commander having overall control of the operation. This normally would be located immediately in rear of assault battalions to relieve the assault commanders of responsibility for traffic in their rear. Other traffic regulating lines may be established to facilitate the control of vehicular density throughout the division and to indicate the forward edge of corps area of responsibility.

b. Staging areas are located far enough from the river to allow the maximum use of alternate routes to crossing sites. They are located and employed to handle traffic entering the assault unit's area. Military police assigned to the vicinity of the staging area will—

- (1) Provide traffic control into and out of the staging areas..
- (2) Insure that all vehicles clear the ERP.
- (3) Enforce all orders and regulations with emphasis on movements.
- (4) Advise the staging area commander, when requested, on the internal organization of the staging area as it affects traffic control.

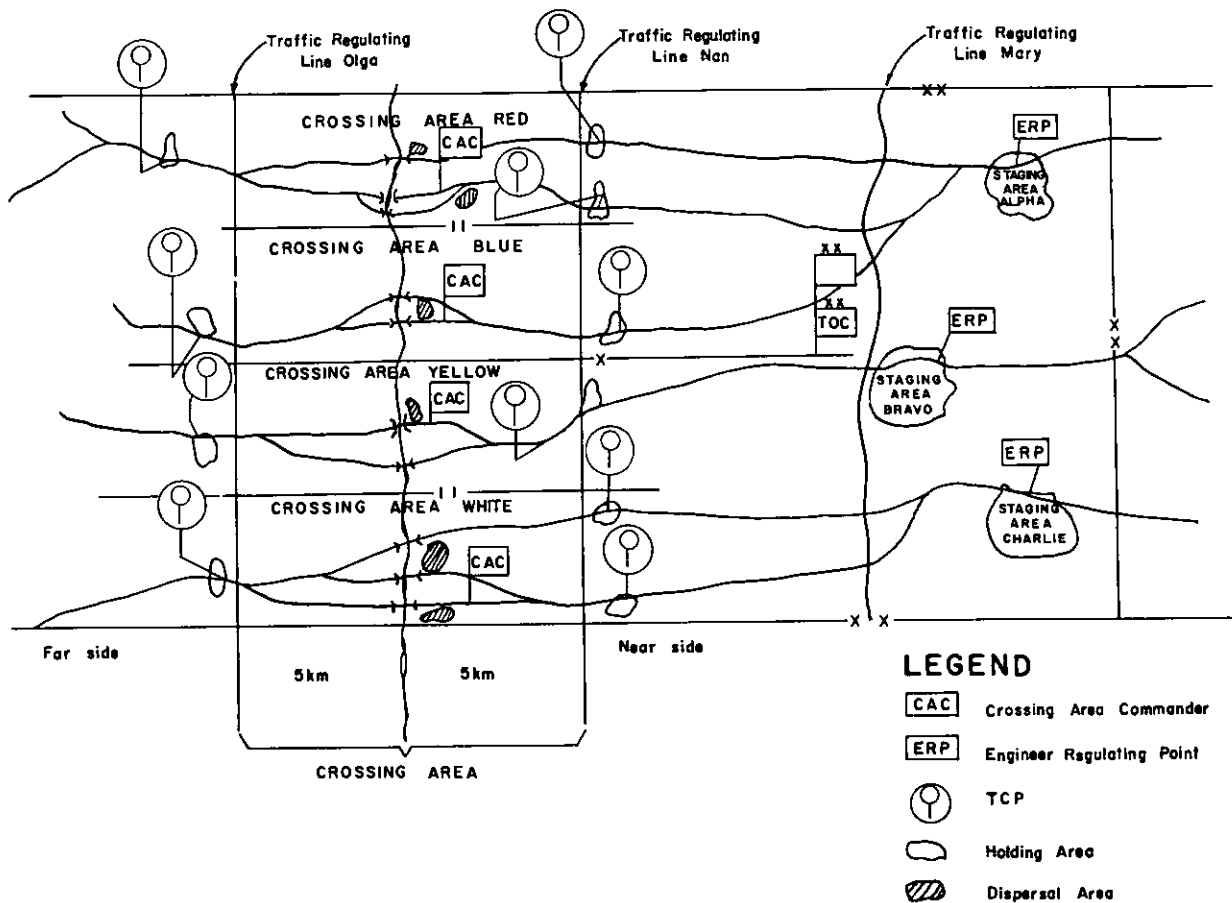


Figure 66. Traffic facilities for a river crossing.

(5) Assist in providing security, refugee control, and straggler control.

c. Holding areas are located on the near and far side of the river just outside of the crossing area. The holding areas are located off the road and assist in the continued flow of traffic by preventing undue congestion of vehicles in the crossing area. Military police establish and operate holding areas as outlined in paragraph 121.

168. Crossing Area

a. The crossing area is the responsibility of the crossing area commander. Military police are attached to the crossing area commander for the operation.

b. Dispersal areas are defined zones within the crossing area in proximity to the crossing means where vehicles can be halted and dispersed. These areas may be operated by the military police for the crossing area command-

er. Dispersal areas operate as holding areas, however, every effort is made to conceal the areas from the enemy as well as to disperse the vehicles to reduce the attractiveness of the target. The use of the dispersal area prevents congestion on the crossing access road by allowing for temporary storage of the crossing traffic when the traffic has been disrupted or there is a reduction in the crossing means. Vehicles are dispatched from the dispersal area to the crossing site in accordance with the capability of the reduced crossing means. The military police employed in the dispersal area operate under and are in constant communication with the crossing area commander.

169. Far Side

On the far side, traffic control emphasis is on the free flow of traffic from the crossing site, and on straggler control. These functions are accomplished by TCP, motor patrols, and by military police at holding areas.

Section II. AMPHIBIOUS OPERATIONS

170. General

Military police traffic control personnel land early during amphibious assault operations. Their mission is to facilitate the movement of personnel and equipment from the beachhead.

171. Principles of Beachhead Traffic Control

a. The function of traffic control on the beachhead is to assist the commander in continuing the operation by eliminating delays and congestion.

b. Maximum dispersion is enforced.

c. Personnel and equipment are moved off the beach area without delay according to the commander's plan.

d. Maximum use is made of direction and control signs.

e. Vehicle drivers and other personnel will be directed to use roads and trails that exist or are outlined (fig. 67).

f. All military police positions will act as information posts.

g. All military police patrols will conduct continuing route and area reconnaissance.

172. Problems Inherent in Amphibious Operations

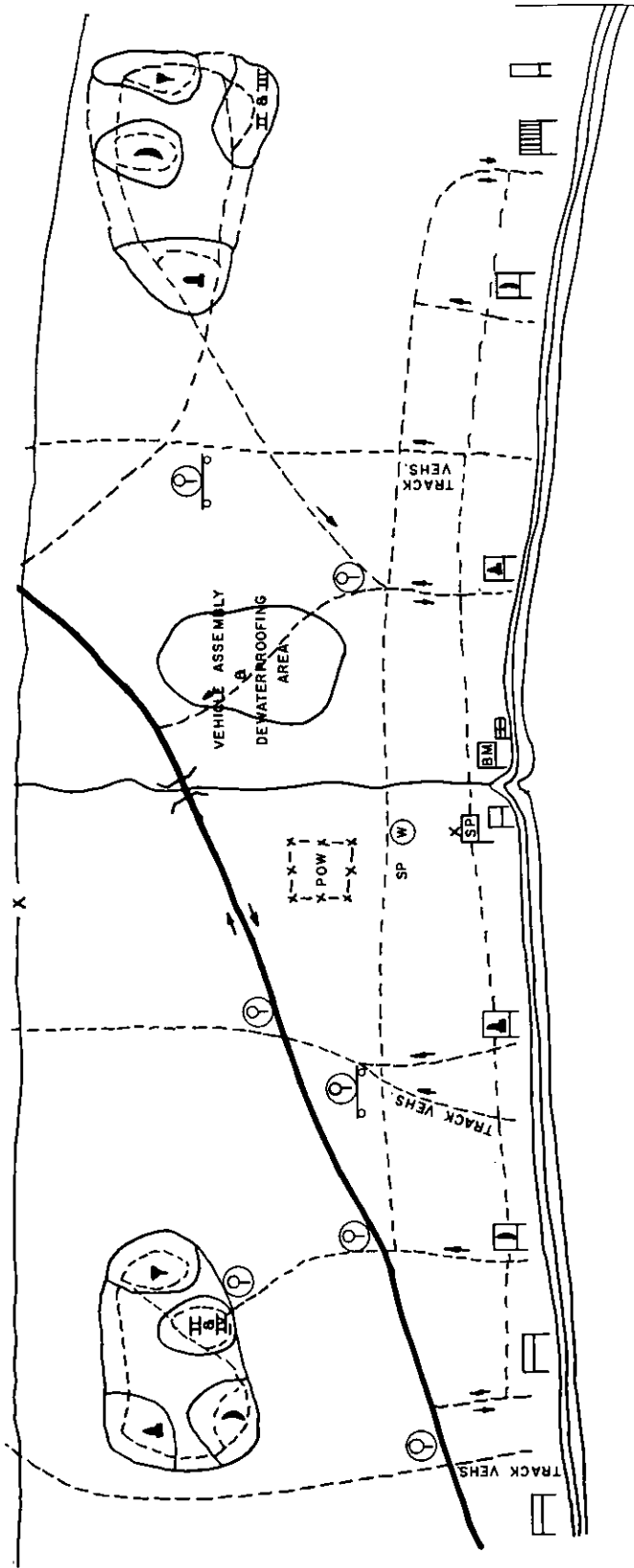
a. Landing areas may or may not have roads. Engineer, transportation, and military police units will often establish trails and roads where none previously existed. This is accomplished by signs and engineer tape.

b. The area of assault will not have received a ground reconnaissance prior to the landing. This restricts the information available to the military policeman.

c. The area is normally subjected to enemy fire.

d. Landing areas are characterized by congestion and road users who are not familiar with the area.

e. For detailed information on amphibious operations, see FM 31-12 and FM 31-13.



NOTE: SEE FM 5-144

Figure 67. Sketch of a beach traffic circulation plan.

Section III. AIRBORNE OPERATIONS

173. General

Military police elements will accompany the initial assault force. The duties these military police have, in addition to traffic control, include straggler control, security of the headquarters, and handling of prisoners of war.

174. Traffic Control Techniques

The traffic control techniques used in the drop zone and the airhead are adaptations of conventional military police techniques with

added emphasis on security considerations, both for the security of the military police and for the traffic they are controlling. Normally, initial military police elements do not use reflectorized equipment because it may reveal their position to the enemy. Standard signs and sign making equipment are not used. They are replaced by small improvised cloth signs that are prepared in advance of the drop and issued to the individual military policeman. As the airhead is expanded, and the number of vehicles inside it increases, regular traffic patterns and traffic control duties emerge.

Section IV. DESERT OPERATIONS

175. General

Traffic control operations and principles are the same for desert operations as for other operations except as modified below:

a. The physical environment of the desert requires the continuous attention of the individual to such factors as exposure to the sun, changes in temperature, and water consumption. The military policeman on traffic control duty must evaluate the effect of the environment on his capability to perform duty.

b. The desert is characterized by a lack of developed roads, camouflage, and cover. Since all vehicles will leave tracks in the desert, it is a security measure to enforce the use of designated routes.

c. The lack of terrain features requires the military policeman to understand land navigation and to assist by acting as a reference point for personnel navigating over the desert.

176. Operations

a. The major movement of troops will be by mechanized means which, with the lack of navigation reference points, will require a large

commitment of military police to traffic control duties.

b. Security considerations during desert operations are affected by:

- (1) The lack of camouflage and cover. When military police prepare their position, they must camouflage the position and all material used or distributed in preparing the position. Material for cover must normally be transported to positions.
- (2) The great distance which light travels. Enforcement of blackout regulations is a major military police function.

c. The adverse effect of the desert on vehicles and personnel requires military police to be prepared to perform desert rescue functions.

d. At the normal command post (CP) or supply complex one dismount point is established; however, during desert operations both CP and supply complexes are characterized by multiple entrances thus requiring multiple dismount points.

e. For detailed information on desert operations, see FM 31-25.

Section V. JUNGLE OPERATIONS

177. General

The jungle area is normally characterized by lack of roads and restricted vehicle traffic. Traf-

fic control is therefore extremely critical and is directed to insuring that movement is by schedule.

178. Operations

a. Techniques of traffic control are similar for jungle operations as for other operations. There usually will be large numbers of defiles and crossing sites that will require traffic control.

b. Prescribed distances and intervals must be

rigidly maintained to prevent damage to the limited road net.

c. Jungle growth offers the enemy an excellent opportunity to utilize guerrilla tactics thus increasing military police traffic control security requirements.

d. For detailed information on jungle operations, see FM 31-30.

Section VI. NORTHERN AND MOUNTAIN OPERATIONS

179. General

a. The environment is a major factor, and the human element is all-important in military northern and mountain operations. One must know how to survive in this environment (FM 31-70).

b. Because of the environment, maintenance of equipment is of paramount importance.

c. The mobility of individuals and units is restricted by adverse weather and terrain. Once movement and momentum have been achieved every effort must be made to maintain them.

d. Traffic control operation remains basically the same in the northern environment except as modified by the need to survive the climate. Because of the climate, an active "buddy system" should be employed by personnel assigned to traffic duty.

180. Principles of Operations

a. Reflectorized signs should be used behind

the light line and luminous signs forward of the light line. When erecting temporary signs the military policeman should insure that they do not blend with the terrain or ground cover.

b. All single lane roads will have turnouts used to reduce delays and congestions. Such turnouts must be well marked.

c. Turnarounds are permitted only at designated places.

d. When vehicles must pass on a narrow road, the vehicle being passed should come to a complete stop on the dangerous side of the road. The passing vehicle should then proceed around the stopped vehicle on the safer side (fig. 68).

e. The adverse effect of the climate requires military police to be prepared to perform rescue functions.

f. For details of northern operations see FM 31-70 and FM 31-71. For details of mountain operations, see FM 31-72.

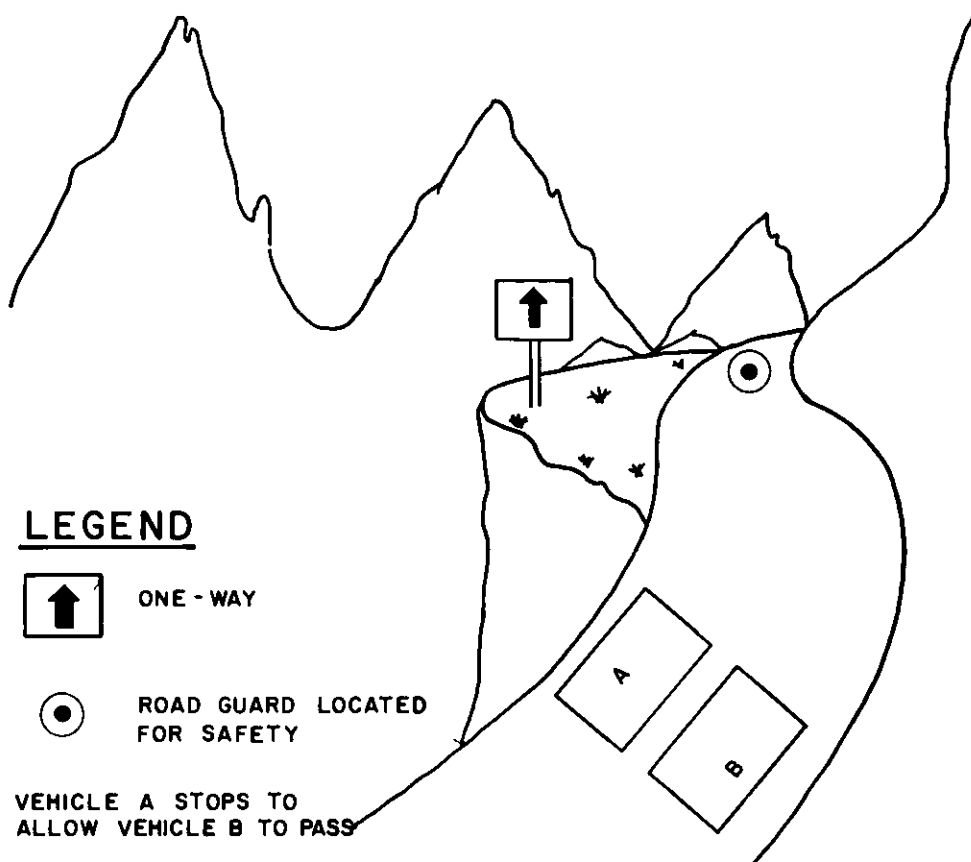


Figure 68. Example of vehicle passing on a narrow mountain road.

Section VII. AREA DAMAGE CONTROL

181. General

Area damage control operations have the objective of minimizing the immediate effects of a mass destruction attack or a natural disaster. These operations will be under the direction of an incident officer assigned to each disaster or attacked area. The incident effects may be characterized by:

- a. Panic.
- b. Desire of persons to flee the area.
- c. A disruption of communication.
- d. Blocking of routes and roads.

182. Immediate Action During a Nuclear or Chemical-Biological Attack

a. Traffic control personnel will report the incident using an NBC report and will utilize survey equipment at once to determine and report all information.

b. Hold all nonemergency traffic moving towards the incident area and expedite traffic moving away from the area.

c. Increase straggler control activity.

d. Traffic that must move past the incident area should be directed to the right side of the area.

e. Military police patrols should establish a route around the incident area that is free for movement, and report this route to the military police and the incident officer unit. If communication is lost, the senior military policeman will establish the rerouting, place signs on it, and adjust the TCP to provide control.

183. Military Police at the Incident Scene

a. Upon the report of an incident the military police unit will dispatch traffic control elements

to the incident area. These elements are under the control of the incident officer once they arrive at the area.

b. Traffic control posts will be established—

- (1) At entrances and exits into the area.
- (2) At assembly areas.
- (3) At critical points.

c. Traffic patrols will cordon off the area by their patrol activity.

d. A military police team will erect, as appropriate, temporary direction signs, traffic signs, and contamination markers.

e. Military police will also provide escorts, straggler control, refugee control, and defile control as required at the incident area.

APPENDIX I

REFERENCES

1. Field Manuals

1-5	Army Aviation Organizations and Employment
1-80	Aerial Observer Training
1-100	Army Aviation
3-5	Chemical, Biological, and Radiological (CBR) Operations
3-12	Operational Aspects of Radiological Defense
3-15	Nuclear Accident Contamination Control (To be published)
5-15	Field Fortifications
5-20	Camouflage, Basic Principles and Field Camouflage
5-22	Camouflage Materials
5-34	Engineer Field Data
5-36	Route Reconnaissance and Classification
6-135	Adjustment of Artillery Fire by the Combat Soldier
7-11	Rifle Company, Infantry, Airborne Infantry and Mechanized Infantry
11-8	Field Radio Relay Techniques
19-1	Military Police Support, Army Division (To be published)
19-2	Military Police Support, Field Army (To be published)
19-3	Military Police Support in the Communications Zone
19-5	The Military Policeman
19-20	Military Police Investigations
20-22	Vehicle Recovery Operations
21-6	Techniques of Military Instruction
21-11	First Aid for Soldiers
21-26	Map Reading
21-30	Military Symbols
21-31	Topographic Symbols
21-40	Small Unit Procedures in Chemical, Biological, and Radiological (CBR) Operations
21-41	Soldier's Handbook for Chemical and Biological Operations and Nuclear Warfare
21-60	Visual Signals
21-75	Combat Training of the Individual Soldier and Patrolling
21-150	Combatives
23-30	Grenades and Pyrotechnics
24-18	Field Radio Techniques
24-20	Field Wire and Field Cable Techniques
30-5	Combat Intelligence
30-7	Combat Intelligence Battle Group, Combat Command, and Smaller Units
30-10	Terrain Intelligence
31-11	Doctrine for Amphibious Operations
31-12	Army Forces in Amphibious Operations (The Army Landing Force)
31-13	Battle Group Landing Team (Amphibious)

31-16	Counter guerrilla Operations
31-22	U.S. Army Counterinsurgency Forces
31-25	Desert Operations
31-30	Jungle Operations
31-60	River Crossing Operations
31-70	Basic Cold Weather Manual
31-71	Northern Operations
31-72	Mountain Operations
41-10	Civil Affairs Operations
55-15	Transportation Corps Reference Data
55-30	Motor Transportation Operation
55-31	Motor Transport Service in Theaters of Operations
55-54	Highway Capability Estimating Guide
57-35	Airmobile Operations
61-100	The Division
101-5	Staff Officers' Field Manual; Staff Organization and Procedure

2. Technical Manuals

3-220	Chemical, Biological, and Radiological (CBR) Decontamination
5-210	Military Floating Bridge Equipment
5-216	Armored Vehicle Launched Bridge
5-277	Panel Bridge, Bailey Type, M2
5-312	Military Fixed Bridges
21-300	Driver Selection and Training. (Wheeled Vehicles)
21-305	Manual for the Wheeled Vehicle Driver
55-710	Transportation Services at CONUS Installation (To be published)

3. Technical Bulletins

PMG 5	Traffic Accident Recording
PMG 6	Casts and Molds
PMG 9	Investigative Photography
PMG 14	Tool Marks and Restoration of Numbers
PMG 18	Hit-and-Run Accidents
PMG 27	Crime Scene Processing
PMG 33	Glass Fractures
PMG 35	Traffic Surveys (To be published)

4. Army Regulations

1-70	Standardization Among Armies of United States-United Kingdom-Canada
1-71	Standardization Among the Countries of the North Atlantic Treaty Organization
55-162	Permits for Oversize, Overweight, or other Special Military Movements on Public Highways in the Contiguous States and the District of Columbia of the United States
190-5	Motor Vehicle Traffic Supervision
190-8	Off Post Military Police Activities
190-15	Traffic Accident Investigation
190-22	Seizure and Disposition of Property
190-45	Records and Forms
190-46	Provost Marshal Activities

(C) 190-60	Physical Security of Atomic Weapons
195-10	Military Police Criminal Investigative Activities
210-10	Administration
320-5	Dictionary of United States Army Terms
320-50	Authorized Abbreviations and Brevity Codes
360-5	General Policies, Public Information
380-5	Safeguarding Defense Information
385-10	Army Safety Program
385-40	Accident Reporting and Records
385-55	Prevention of Motor Vehicle Accidents
415-35	Minor Construction
600-55	Motor Vehicle Driver-Selection, Testing and Licensing
633-1	Apprehension and Restraint
643-25	Registration of Motor Vehicles Overseas
670-5	Male Personnel
700-10	Registration of Motor Vehicles
700-2300-1	Motor Vehicles
746-2300-1	Color and Marking of Vehicles and Equipment

5. DA Pamphlets

108-1	Index of Army Motion Pictures, Film Strips, Slides and Phono-recordings
310-series	Military Publication Index Series

6. International Agreements

STANAG 2010	Standardization of Bridge Classification Markings
STANAG 2012	Military Route (Itineraire) Signing
STANAG 2021	Computation of Bridge, Raft and Vehicle Classifications
STANAG 2024	Military Road Traffic Lighting Regulations
STANAG 2025	Basic Military Road Traffic Regulations
STANAG 2151	Road Network—Definitions and Characteristics
STANAG 2154	Definitions and Regulations for Military Motor Movements by Road
SOLOG 55	Military Road Traffic Lighting Regulations

7. Miscellaneous Publications

- Manual for Courts-Martial, United States, 1951.* United States Government Printing Office, Washington, D.C., 1951
- Uniform Vehicle Code.* National Committee on Uniform Traffic Laws and Ordinances, Washington, D.C., 1962
- Manual on Uniform Traffic Control Devices for Streets and Highways.* Public Roads Administration. United States Government Printing Office, Washington, D.C., 1961
- Traffic Accident Investigator's Manual.* Traffic Institute, Northwestern University, Evanston (Ill.), 1963
- Model Traffic Ordinance.* National Committee on Uniform Traffic Laws and Ordinances, Washington, D.C., 1962
- Traffic Engineering Handbook.* Institute of Traffic Engineers, New Haven, Connecticut, 1950

APPENDIX II

NATO SIGNS

1. General

This appendix is based on STANAG No. 2012 (Edition No. 2). Details of this agreement and other traffic control related agreements are contained in FM 19-2 and FM 19-3.

2. Hazard Signs

a. The signs are used to indicate a traffic hazard.

b. The signs will be square in shape and will be placed with one diagonal vertical.

c. If the hazard to be signed has been provided for in the Geneva Convention or host country's system, the appropriate symbol under

the Geneva Convention or the host country's system will be superimposed on a yellow square.

d. A purely military sign not included in the Geneva Convention or the host country's system will be yellow, with the legend or symbol inscribed thereon in black.

e. For examples, see figures 69 and 70.

3. Regulatory Signs

a. These signs are used to regulate and control traffic and to define the light line.

b. Regulatory signs will be square in shape. They will be black, with the legend or symbol

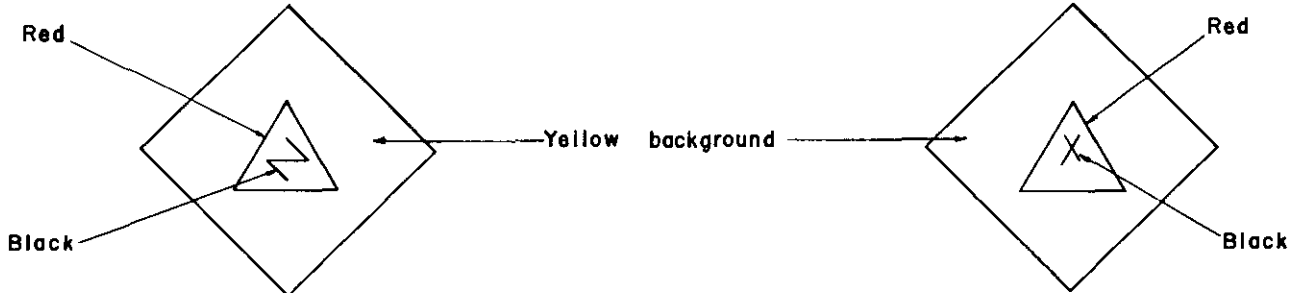


Figure 69. Hazard signs provided for by the Geneva Convention.

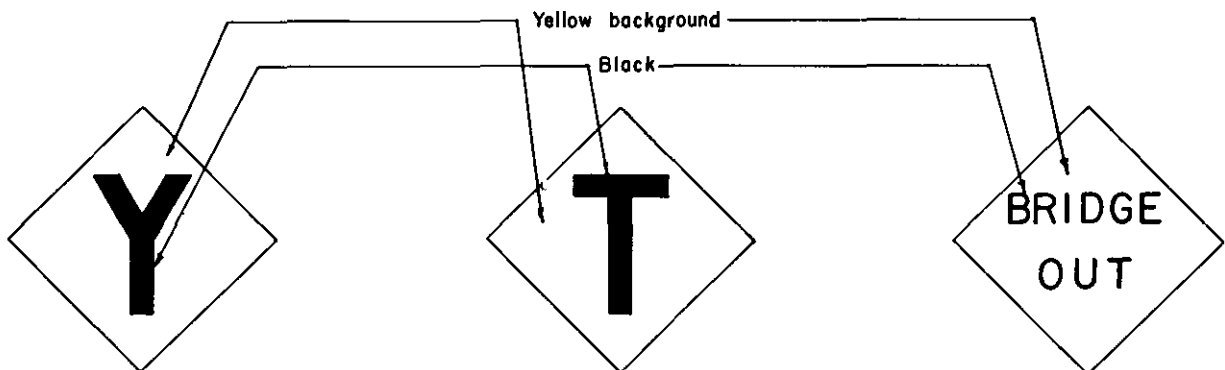


Figure 70. Hazard signs not provided for by the Geneva Convention.

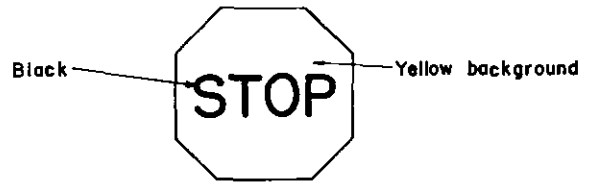
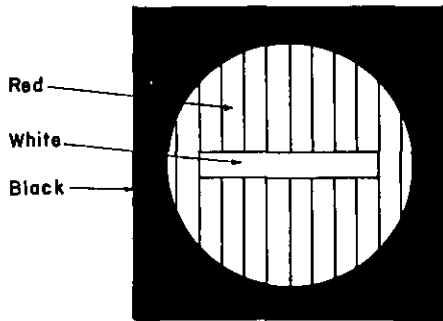


Figure 71. Regulatory signs.

superimposed in white, with the following exceptions:

- (1) Bridge classification signs will be in accordance with STANAG No. 2010 (para. 158).
- (2) Stop signs for military purposes only will be octagonal. They will be yellow with the word "STOP" superimposed in black.
- (3) "No entry" signs will have the Geneva Convention symbol superimposed.
- (4) Blackout signs (fig. 72).
- (5) When the military must erect signs to be complied with by civilians, and suitable signs are already provided for by the Geneva Convention or host country system, these signs will be used.

c. For examples of regulatory signs, see figures 71 and 72.



Figure 72. Blackout signs.

4. Route Guide Signs

a. Guide signs for routes will be rectangular in shape with the long axis vertical. They will be black, with legend or symbol superimposed in white.

b. The legend on a route guide sign (i.e. a guide sign used to indicate routes) will consist of:

- (1) The route number.
- (2) Appropriate directional disc.

c. In addition, route signs may show the direction of the traffic. In the case of axial routes, differentiation between the stream of traffic moving to the front and the stream moving to the rear, will be shown by means of a traffic disc with barred arrow showing the stream to the rear. On route signs for lateral routes, the standard letter N, E, S, W, NE, SE, NW and SW will be used to indicate the general direction of movement of each traffic stream.

d. For examples, see figures 73, 74, and 75.

e. For alternate routes, see paragraph 9.

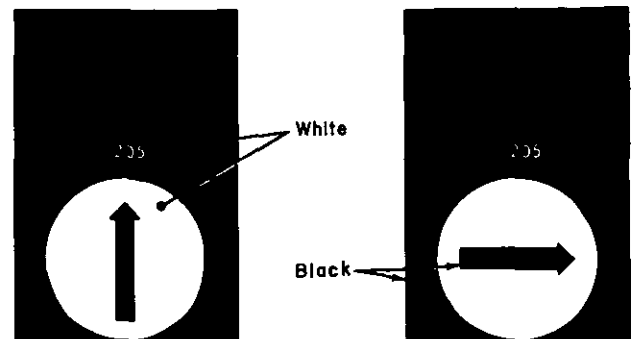


Figure 73. Examples of axial route signs for traffic going to the front.

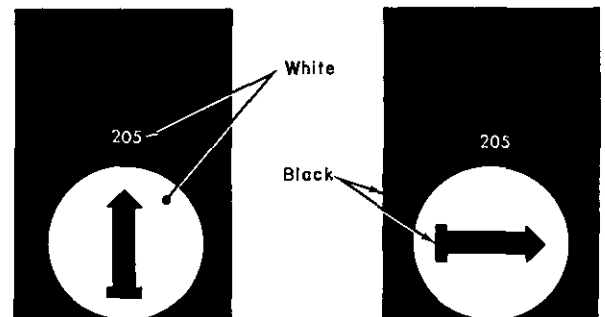


Figure 74. Examples of axial route signs for traffic going to the rear.

5. Guide Signs For Casualty Evacuation Routes

a. On a rectangular white background the following information is shown in red:

- (1) Directional arrow.
- (2) Red cross.
- (3) Unit or subunit designation in abbreviated form or by using military symbols (only if required for casualty evacuation.) Additional information, such as national markings, can also be shown if desired (fig. 76.)

b. Instead of using a rectangular white background as indicated in a, above, it is permissible to use as background, a normal directional disc (para. 8, below), four segments of which are cut out to give a cruciform shape. The same information is shown in red on white (a, above).

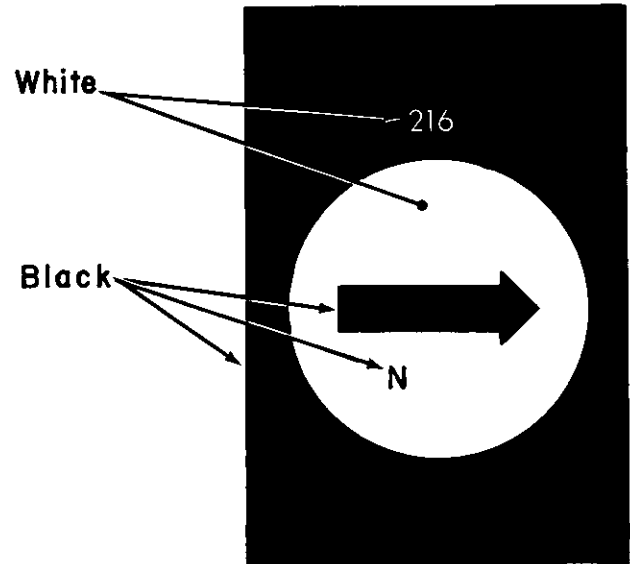
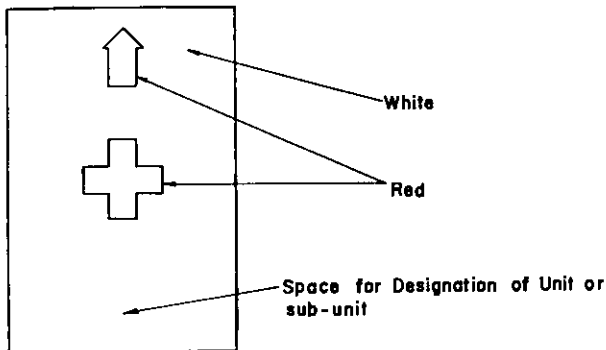


Figure 75. Example of lateral route sign.

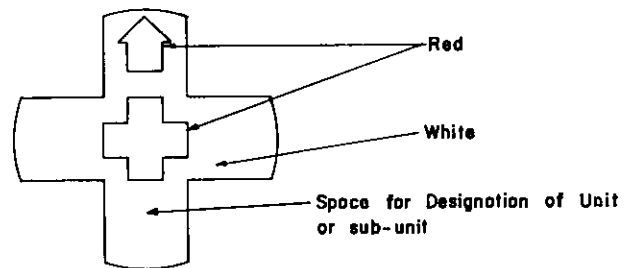


Figure 76. Casualty evacuation route signs.

6. Other Guide Signs

Other guide signs shall be rectangular in shape (fig. 77). This type of sign will be used, for instance, to mark the routes to headquar-

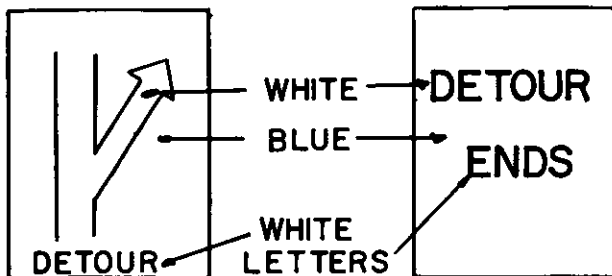


Figure 77. Examples of general traffic signs.

ters, dumps, and similar installations or units. The symbol will be white on a black background.

7. Detour Signs

The detour sign will be a white arrow, barred or not, on a blue square, placed as shown in figures 78 and 79. The number of the diverted main route will be shown—

a. either painted on the square over the arrow, or

b. added under the square by means of panels already provided on route guide signs.

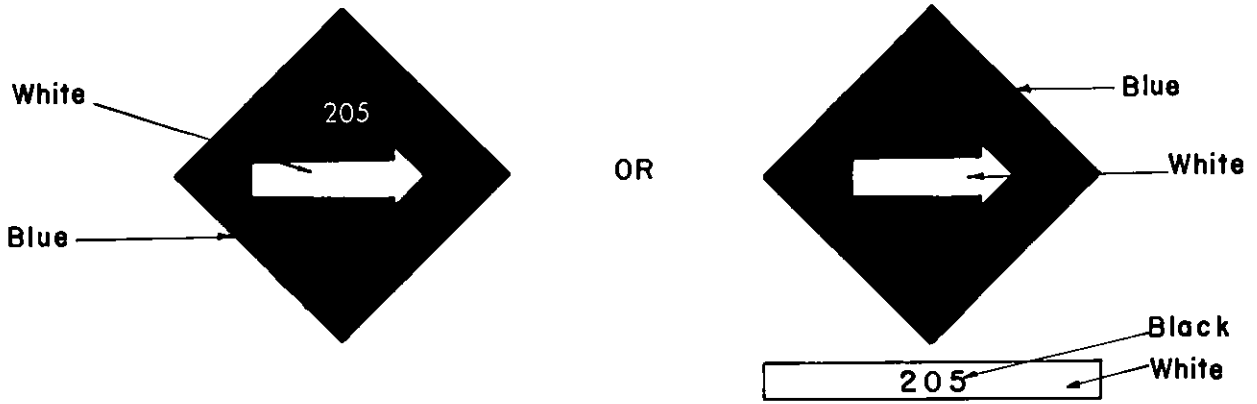


Figure 78. Examples of detour signs for traffic going to the front.

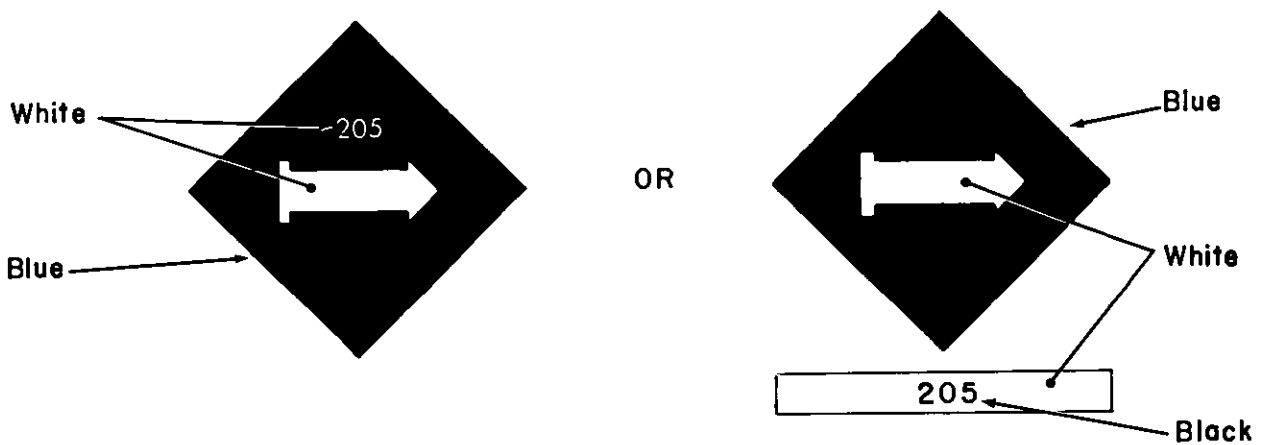


Figure 79. Examples of detour signs for traffic going to the rear.

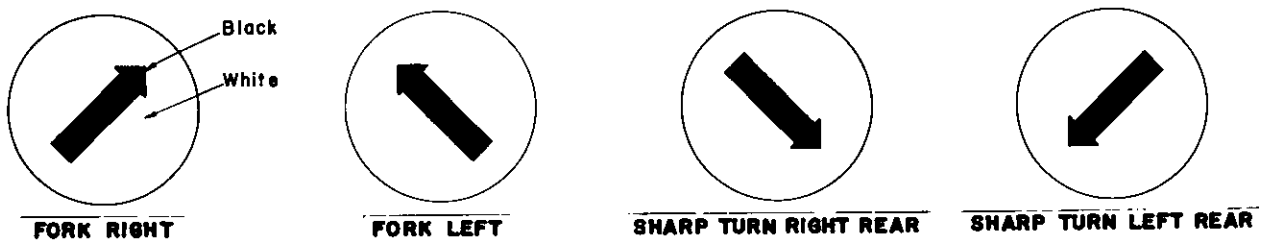


Figure 80. Example of directional discs.

8. Directional Discs

a. *Uses of Discs.* Directional discs will be used to supplement other guide signs to indicate the direction of a route. In addition they will be used with any major unit sign to indicate the route to that unit.

b. *Details of Discs.*

(1) The disc consists of a black arrow with

or without bar on a white background. The disc may be used on a black background or without a background.

(2) The disc will have eight equally spaced holes around the circumference to allow the disc to be nailed with the arrow pointing in the appropriate direction.

(3) For examples, see figures 80 and 81.

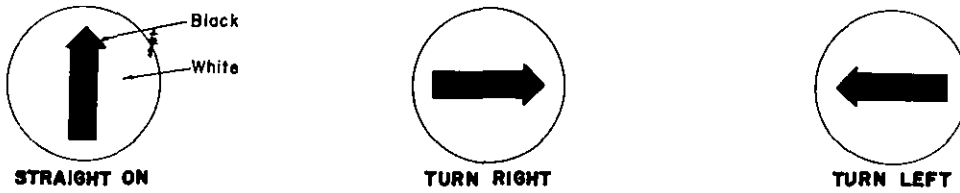


Figure 81. Example of directional discs.

c. Restriction of the Use of Discs.

- (1) The use of the disc is restricted to axial and lateral routes. To avoid confusion, battalions and lower units are not permitted to use directional discs as a guide to those units.
- (2) Units not allowed to use directional discs may use any arrow sign, providing the color and shape are different from those used for directional discs.

used in conjunction with route numbers, as a route sign (figs. 82, 83, and 84).

9. Alternate Route Signs

Alternate route signs are directional discs

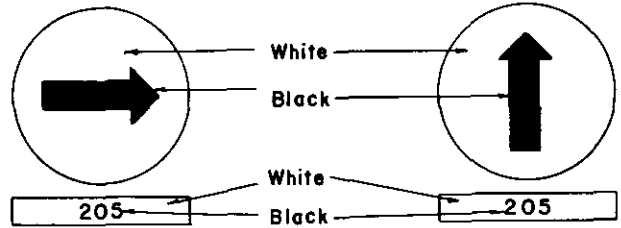


Figure 82. Example of alternate route signs for traffic going to the front.

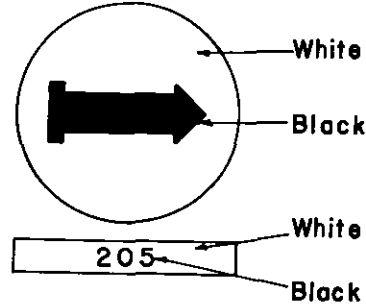
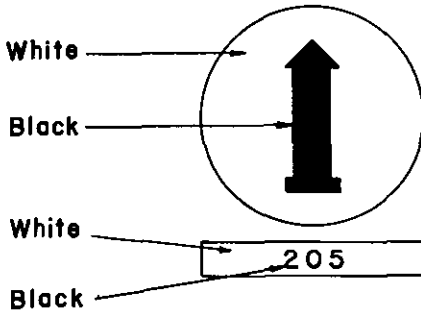


Figure 83. Example of alternate route signs for traffic going to the rear.

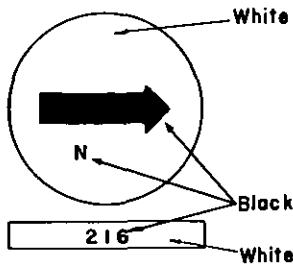


Figure 84. Example of alternate lateral route signs.

APPENDIX III

HAND SIGNALS

1. General

The hand signals prescribed in this appendix are based on Annex C, STANAG 2025 (Edition No. 2), 22 June 1962. These signals are applicable within the Continental United States and with member nations of the North Atlantic



Figure 85. Correct stance assumed by a military policeman while directing traffic in the theater of operations.

Treaty Organization; however, they may require modification when used with personnel of other nations. The military policemen directing traffic will always assume the stance prescribed in paragraph 40 of this manual as the basic position for directing traffic.

2. To Stop Traffic

a. To stop traffic within NATO countries the military policeman will raise both arms horizontally, palm upward, and face in one of the directions from which the traffic is coming that is to be stopped. This signal is used to stop traffic approaching both the front and rear of the military policeman.



Figure 86. NATO signal to stop traffic approaching in front and behind the military policeman.

b. To stop traffic from the right, the military policeman, keeping his feet in place, turns his face to the right, looking carefully at the traffic to insure his signal can be understood and complied with by the traffic; he thrusts his right arm to the right and upward bending it at the elbow slightly. The military policeman's fingers and thumb are extended and joined, the palm is flat and the entire hand is clearly visible to oncoming traffic.



Figure 87. Military policeman stopping traffic from the right.

c. To stop traffic from the left, the military policeman, keeping his feet in place, turns his face to the left, looking carefully at the traffic to insure that his signal can be understood and complied with by the traffic; he thrusts his left arm to the left and upward, bending it at the elbow slightly. The military policeman's fingers and thumb are extended and joined, the palm is flat and the entire hand is clearly visible to oncoming traffic.

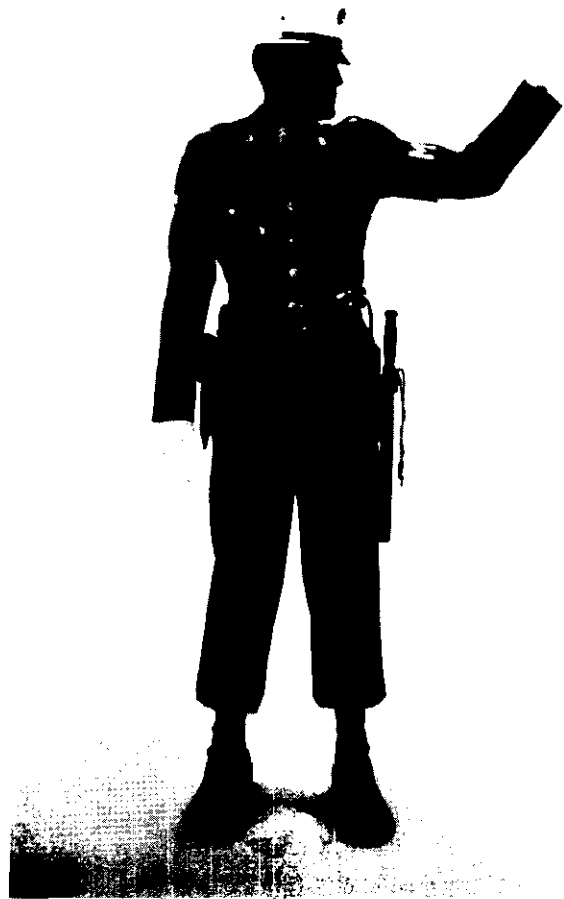


Figure 88. Military policeman stopping traffic from the left.

d. To stop traffic in the front, the military policeman raises his left arm smartly to the front, keeping the fingers and thumb extended and joined, palm facing towards the traffic so that the entire hand is clearly visible to oncoming traffic.

e. To stop traffic from the rear, the military policeman bends the left knee slightly, twisting the body to the right without moving his feet, turning his head and eyes to the right and rear. He then thrusts his right arm outward and upward, fingers and thumb extended and joined, palm flat, the entire hand clearly visible to traffic. The right arm is used because traffic normally approaches the rear of the military policeman from the right.

Note. The normal NATO signal to stop traffic from the front or rear is the front or rear of the military policeman's body (para. 2a above).

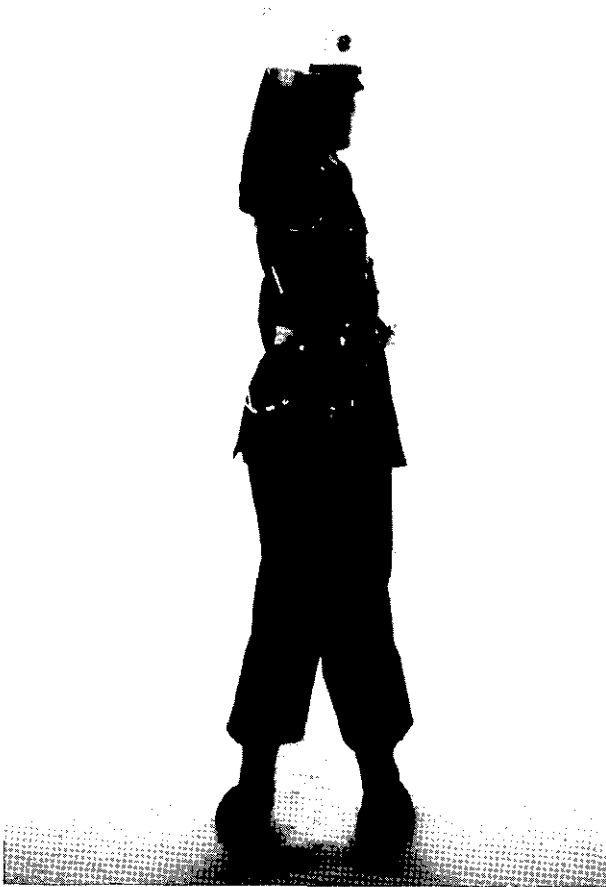


Figure 89. Military policeman stopping traffic from his rear.

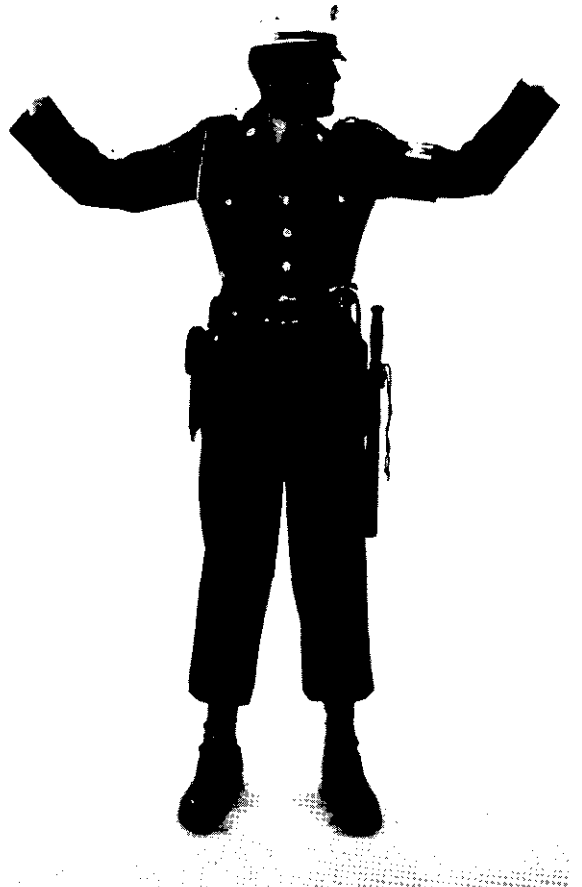


Figure 90. Military policeman stopping traffic from his right and left.

3. Changing Traffic Flow Direction

a. Traffic is normally stopped from the military policeman's right first by using the signal outlined in paragraph 2b above.

b. While maintaining the hand signal to stop traffic from the right, the military policeman executes a signal to stop traffic from his left (para. 2c above).

c. The military policeman then turns his body to his right or left so that he faces the traffic that he has just stopped. (The determination to turn either right or left is made by the military policeman so that he may face the stopped traffic that has the largest normal volume.) While making this turning motion, the military policeman lowers his arms to a horizontal so that when he has completed the turn his arms are horizontal, palms faced upward, see figure 86.

4. Bringing Traffic Through

a. *Traffic from the right.* Normally the military policeman will start traffic moving through his position from the right. He turns his head and eyes smartly to the right. The right hand is then moved from the stop position shown in figure 86, in a 180° arc across the front of his body. The right hand is then dropped smartly along his side.

Note. If the driver fails to respond to the signal it will be repeated as necessary.

b. *Traffic from the left.* After having started the traffic from his right, the military policeman turns his head and eyes smartly to the left. He then brings his left arm from the stop position shown in figure 86, and in a 180° arc across the front of his body. The left hand is then dropped smartly along his side.

Note. If the driver fails to respond to the signal, it will be repeated as necessary.



Figure 91. Military policeman bringing traffic through from his right.



Figure 92. Military policeman starting traffic from his left.

5. Right Turns

a. Drivers Making Right Turns From the Military Policeman's Left. The military policeman will look both to the left and left rear, then with the left arm fully extended out from the shoulder, he will point with his first two fingers to the vehicle that is to turn, moving the arm in a sweeping motion to the left (the driver's right and the military policeman's rear). He will point his fingers as far to the rear as his body structure permits without turning his body or moving his feet. This signal will be repeated as necessary.

b. Drivers Making Right Turns From the Military Policeman's Right. The military policeman will look both to the right and to the front, then with the right arm fully extended out from the shoulder, he will point with his first two fingers to the vehicle that is to turn and in a sweeping motion direct it in the direction the driver is to go (the driver's right and the military policeman's front).

c. Driver Making Right Turn From the Military Policeman's Front. The military policeman looks to both the left and right as well as his front prior to giving the signal. With his left arm fully extended from his shoulder, he points his first two fingers at the vehicle that is to make the turn and moves his arm to his left in a sweeping motion (the driver's right and the military policeman's left side).

d. Driver Making Right Turn From the Military Policeman's Rear. The military policeman looks to both the right and left as well as his rear prior to executing a signal. With the right arm fully extended out from the shoulder he points his first two fingers at the traffic that is to make the turn, moving his right arm to its left in a sweeping motion (the driver's right and the military policeman's left) and directs the traffic in the direction that it is to move.

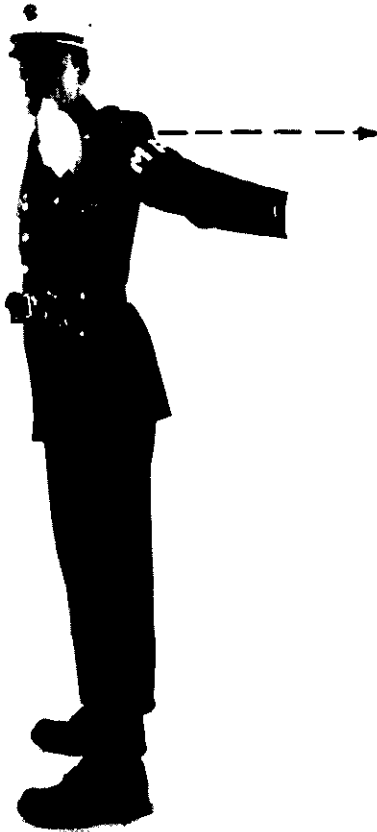


Figure 93. Military policeman directing a driver from his left to make a right turn.



Figure 94. Military policeman directing a driver from his right making a right turn.

6. Left Turns

a. A military policeman directing traffic from his left to make a left turn, looks to his right and extends his right arm, straight out from the shoulder to his front, the palm will be faced towards the traffic making the turn, fingers extended and joined (fig. 98). When the traffic approaching from the military policeman's right has stopped, the military policeman will turn his head toward the traffic making the left turn, extending his left arm straight out from his shoulder towards the traffic making the turn, fingers extended and joined, and in a sweeping motion he will fold his left arm across his body as a signal for the traffic to make its left turn. (It may be necessary to stop traffic in the U.S. by using the signal prescribed in paragraph 2*b* above.)

b. A military policeman directing traffic to make a left turn from his right, insures that traffic from the front and rear is stopped. After looking both to his right and to his rear and stopping traffic from the left in the manner prescribed in paragraph 2*c* above, the military policeman fully extends his right arm straight out from the shoulder, first two fingers extended and joined and points to the traffic to make the turn, then, in a sweeping motion, he moves his arm to the right (the driver's left and military policeman's right rear). He points as far as his body structure will permit without turning the body or moving his feet. When the driver has completed the turn, the military policeman may permit traffic from his left to assume a go flow phase.



Figure 95. Military policeman directing traffic from his front making a right turn

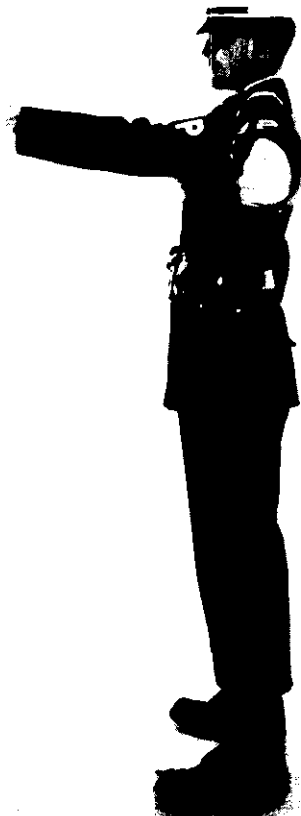


Figure 96. Side view of a military policeman directing traffic from his front making a right turn.

7. Miscellaneous Signals

a. To speed up military traffic, the fist is raised above the head in a clenched fist and the arm is bent at the elbow. The fist is then quickly raised and lowered above the shoulder in a vertical plane.

b. To speed up civilian type traffic within the Continental United States, the military policeman will repeat the appropriate go signal for the direction of the traffic as shown in paragraph 3 above.

c. To slow down traffic both military and civilian, the military policeman extends his arm horizontally then moves it slowly up and down in a vertical plane.

d. When it is necessary for the military policeman to direct a vehicle to a specific point

within an intersection or along the roadway, he will signal the driver by pointing his first two fingers at an imaginary mark on the ground approximately where the military policeman desires the driver to stop his vehicle. This will be used when preparing traffic to make a conflicting or left turn.

8. Directing Traffic with a Baton

a. During night operations the military policeman may use a baton for traffic direction. He will stop traffic by raising the baton to face level, moving it back and forth in front of his face in an approximate 45° arc. The baton light will be on during the time that he is signalling traffic.

b. To direct traffic to go from his right, the military policeman using a baton, extends his

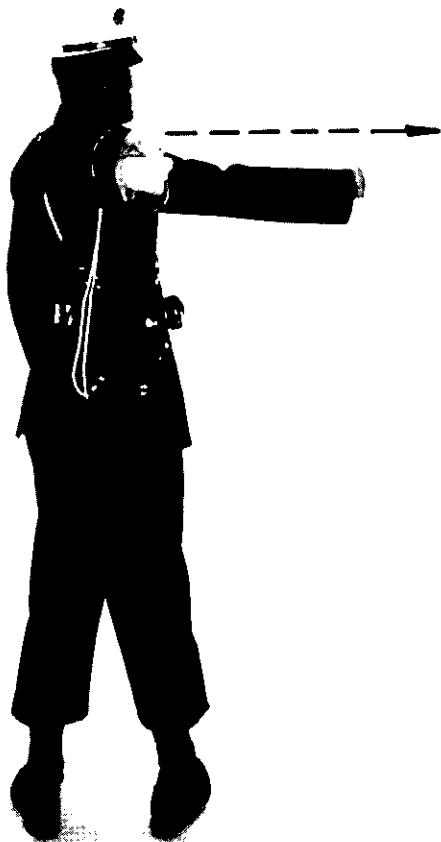


Figure 97. Military policeman directing traffic from his rear making a right turn.

right arm out from his body to the right. Canting the baton slightly to the left so that the light may be visible to the driver, he turns on the light and drops his right arm in a sweeping motion 90° arc, turning off the light when it has completed its arc.

c. To direct traffic to go from his left, the military policeman using a baton, raises his right arm across his body canting the baton slightly to the right, turning on the light so that the driver may see it and then dropping his right arm across his body until it hangs

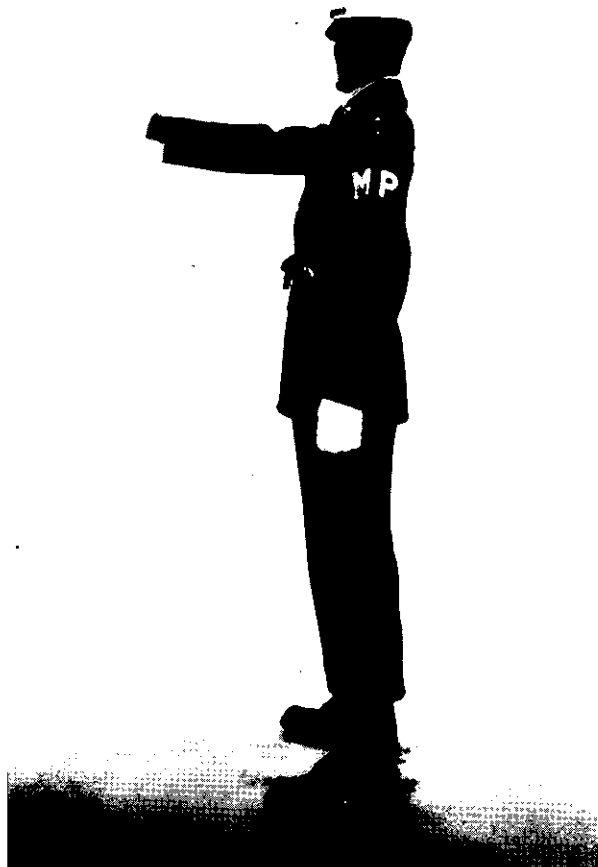


Figure 98. Military policeman stopping traffic from his right to permit a left turn.

naturally by his side where he turns off the light.

d. Other movements when using a baton will be the same as the day movements.

9. Directing Traffic Using a Flashlight

When military policemen are directing military tactical movements or other military type traffic, they may use a flashlight to signal the traffic. Figures 113 to 116 may be used as a guide to the proper signals to be used by the military policeman.

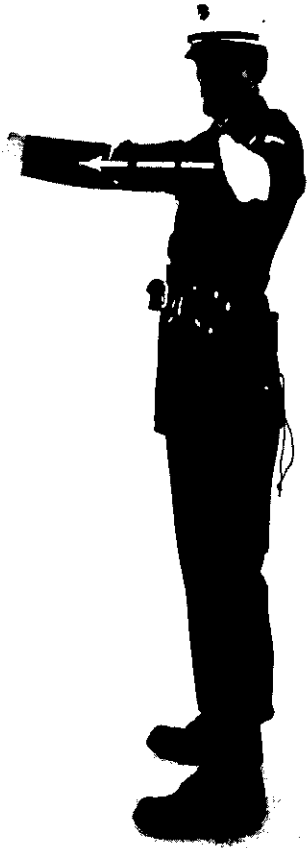


Figure 99. Military policeman allowing traffic from his left to make a left turn.



Figure 100. Military policeman directing traffic from his right making a left turn.



Figure 101. Military policeman signalling military traffic to speed up.



Figure 102. Military policeman signalling traffic to slow down.



Figure 103. Military policeman pointing to imaginary spot on the ground where he desires vehicle to stop.



Figure 104. Military policeman with a baton signaling traffic to stop that is approaching from his front.



Figure 105. Military policeman with a baton signaling traffic to stop that is approaching from his right.

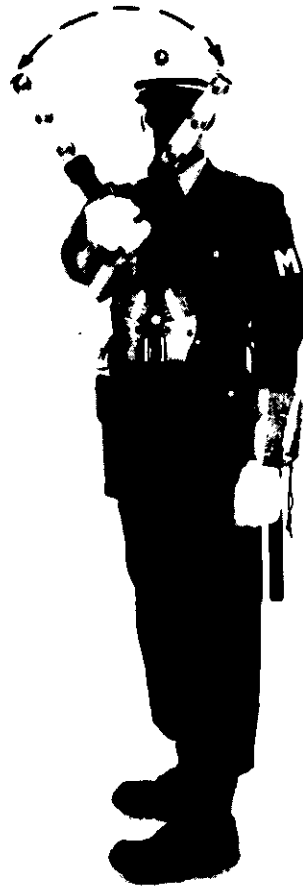


Figure 106. Military policeman with a baton signaling traffic to stop that is approaching from his left.



Figure 107. Military policeman with a baton signaling traffic to stop that is approaching from his rear.

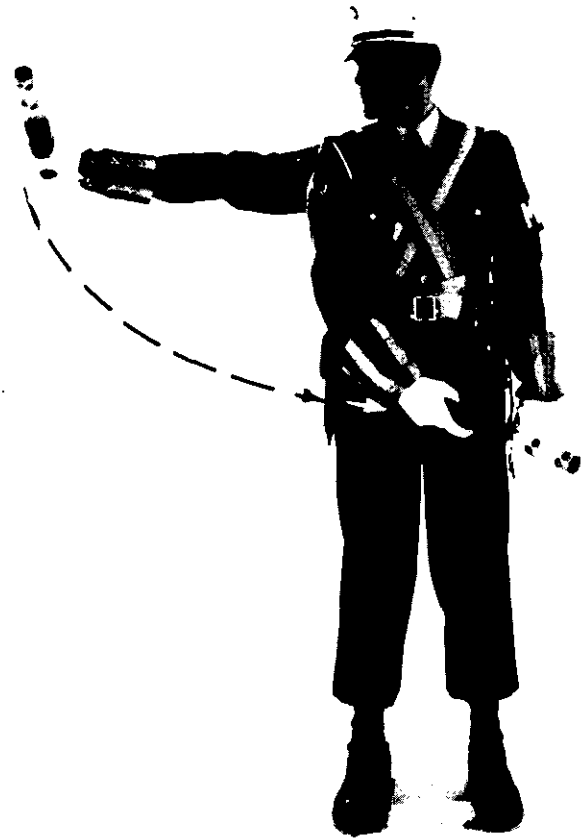


Figure 108. Military policeman with a baton directing traffic to go from his right.



Figure 109. Military policeman with a baton directing traffic to go from his left.

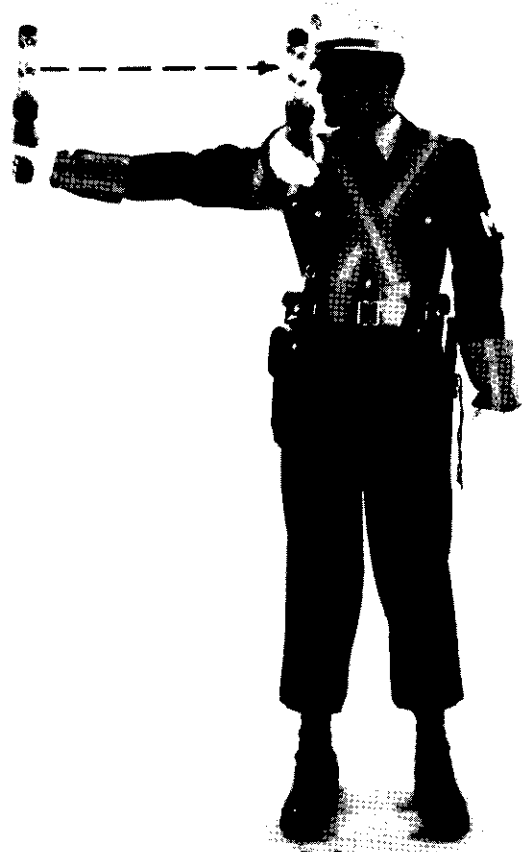


Figure 110. Military policeman with a baton directing a right turn movement for traffic from his right.

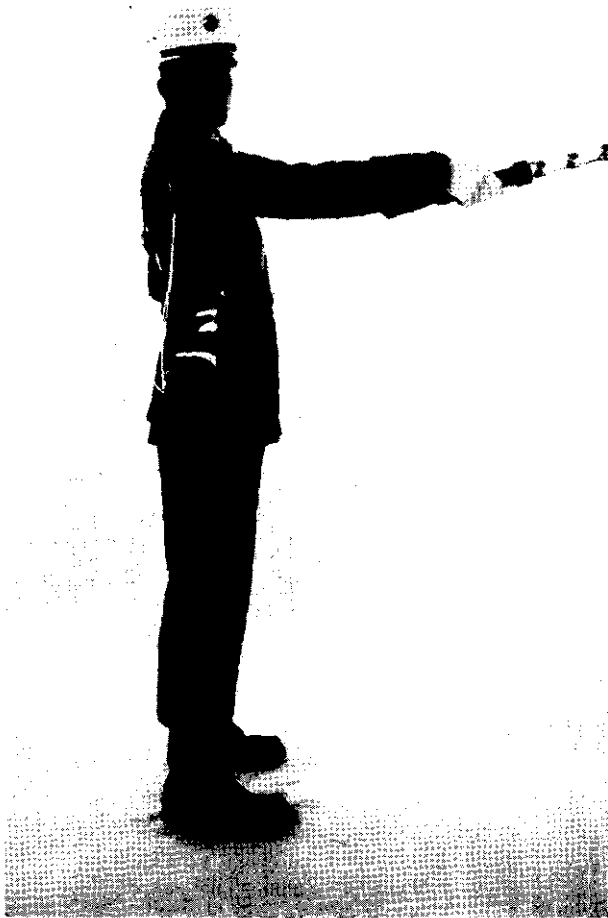


Figure 111. Military policeman using a baton stopping traffic from his right prior to permitting left turn for traffic from his left (para. 6a above and fig. 105).

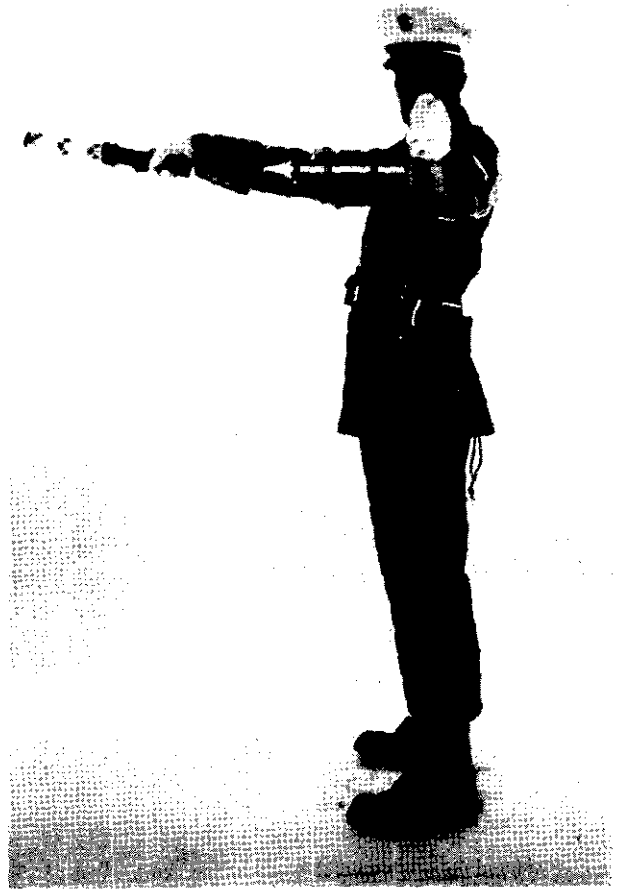


Figure 112. Military policeman using a baton directing traffic from his left to make a left turn.



Figure 113. Stop signal, using ordinary flashlight.



Figure 114. Go signal, using ordinary flashlight.



Figure 115. Right turn signal, using ordinary flashlight.



Figure 116. Left turn signal, using ordinary flashlight.

APPENDIX IV

EQUIPMENT CHECKLIST

I. Suggested Checklist of Organizational and Expendable Equipment

	TCP	Motor patrols	Platoon hq	Defile	Escort	Road blocks	Check-point	Holding area	Crossings	Dismount point
Vehicle.....	1	1	1	* 1	X	X	X	* X	* X	
Radio AN/VRC.....	1	1	1	* X	X	X	X	* X	* X	
Radio AN/PRC.....	(a)			(a)		(a)	(a)	(a)	X	(g)
Water (gal.).....	5		^b 5	5		5	5	5	5	
"C" ration (per ind).....	2	1	1	2		2	2	2	2	
MP packet ^h	1	1	1	1		1	1	1	1	
Compass.....		1	1		* 1			* 1		
First aid kit.....	* 1	* 1	* 1	* 1	* 1	* 1	* 1	* 1	* 1	
Wristwatch.....	* 1	* 1	1					1		
Telephone.....	(a)		(e)	X		3	(a)	(a)	X	X
Wire (WD-1).....	(a)		(e)	X		X	(a)	(a)	X	X
Baton.....	1		1	2		1	1	X	X	1
Flashlight (per ind).....	1	1	1	1	1	1	1	1	1	1
Shovel (D-handle).....	(d) (*)		(b)	(d)		(d)	(d) (*)	(d)	(d)	
Pick.....	(d) (*)		(b)	(d)		(d)	(d) (*)	(d)	(d)	
Chain.....				1		1		1	1	
Rope.....	1	1	1	1	1	1		1	1	
Fire extinguisher.....		1	1	1	1			1	1	
Wrecker.....				* 1				* 1	* 1	
Cross straps and sleeves.....	PER INDIVIDUAL DIRECTING TRAFFIC									
Decontaminating apparatus portable.....			(b)					* 1		
Staple hammer or hammer.....	1	1	1	1		1	1	1	1	* 1
1 doz rr flares.....		1	1	1	1	1	1	1	1	* 1
Grenade fragmentation.....	4	4	4	4	X	X	4	X	X	X
Grenade phosphorous.....		4	4		X	X			X	X
Cook set fld.....	* 1		(b)	* 1		* 1	* 1	* 1	* 1	
Sand bags.....	* X		(b) (*)	X	X	X		* X	* X	
Detector kit chemical.....			1							
Panel marker set.....			1		1	1		1	* X	
Radiac Meter 1M/93.....	1	1	* 1	1		1	1	1	* 1	
Radiac Meter 1M/174.....			1							
Launcher rocket 3.5.....					* 1	X			X	X
Gun machine 7.62.....		* 1	1		X	X			X	X
Lantern elec.....	* 1		(b) (*)				* 1	* 1	* 1	* 1
Flags red.....				X		(e)	(e)	(e)	(e)	(e)
Barbed wire.....			* X			X			X	* X
Ax.....						1		1	1	
Traffic cones.....				(c)		(e)	(e)	(e)	(e)	(e)
Additional equipment.....		(f)	(f)							

X—Number determined by military police unit.

*Nice to have.

a May be substituted for vehicle w/radio if communication can be established with an MP position that has contact with the MP CP.

b At the Platoon CP.

c At the Platoon CP when connected by wire to other positions or units.

d If vehicle is not assigned to this position.

e May be used to channelize traffic.

f When used for a reconnaissance patrol, see paragraph 133 and appendix VIII.

g May be used in place of wire communication.

h See paragraph 3 below.

2. Sign Checklist

	Company basic load g	TCP	Motor patrols	Platoon hq	Defile	Escort	Road blocks	Check- point	Holding area	Crossings	Dismount point
Hazard signs	50			5	X					(b)	
Warning MP activity ahead ^a		(b)			4			4	(b)	(b)	(b)
MP activity		1			2		2	2	1	2	1
Detour		2	5	10	(b)		(b)			(b)	
Directional discs	100	5	5	20	5		(b)	(b)	(b)	5	(b)
Route guide signs	50		^c 5	^c 10	^c 2			^c 2		^c 2	
Instruction signs ^d					(e)		(e)	(e)	(e)	(e)	(e)
Contamination ^f :											
Chemical	50			20							
Nuclear	50			20							
Biological	20			5							

X—Number to be determined
by military police unit.

^a See figure 58.

^b When required.

^c Per route.

^d Locally made.

^e Normally will be required.

^f Usually only assigned with monitoring
and detection equipment.

^g Basic load maintained in addition to
signs issued to platoon and position.

3. Sample MP Packet Content List

Traffic Control Team Map.

Extract of SOI (when equipped with
radio).

Authentication table.

Frequencies and call signs.

Codes.

Message book.

Overlay paper.

Measle map.

Pencils.

Strip maps.

Forms; reports of traffic violations.

Instruction; packet usually includes ex-
tracts of the traffic control plan and
highway regulations.

4. Information Reference Material Checklist for PCS

a. Map of the installation showing building
numbers.

b. Strip maps showing the main facilities and
primary roads.

c. A post telephone book of units and activi-
ties.

d. A map of the surrounding community.

e. A directory of the areas of principal in-
terest surrounding the installation.

f. A copy of the installation traffic regula-
tions.

g. A copy of the local state traffic laws (usual-
ly what is issued to personnel applying for a
driver's license).

h. A list to issue to individuals of post facili-
ties operating hours.

APPENDIX V

GUIDE FOR PHOTOGRAPHING A TRAFFIC ACCIDENT

1. Look For and Photograph

- a. Position of vehicles.
- b. Position of bodies.
- c. Extent of damage to vehicles.
- d. Approach to the point of collision.
- e. Recognizable landmarks.
- f. Position of the center-line of the roadway.
- g. Condition of the roadway.
- h. Damage to fixed objects such as trees, fences, or guard rails.
- i. Oil, water, gas, or other foreign matter on the roadway.

j. Skid marks, tire prints, gouges or scratches on the pavement, ruts or holes in the shoulder or ditches.

k. Traffic signs or lights.

2. Observe the Following Techniques

a. Take a photograph of each vehicle involved with the license plate showing for identification.

b. Photograph damaged vehicle from the front, back, and sides of the vehicle. Never use oblique shots to show damage to a vehicle (fig. 117).



Figure 117. Photograph of a damaged front end.

c. Photograph parts broken off a vehicle before they are put back on the vehicle.

d. Photograph fragile and perishable evidence as early as possible after arrival at the scene.

e. Take a close-up photograph of small pieces of evidence (door handles, broken glass, etc.) at the scene.

f. Photograph the undercarriage of a vehicle before it is removed.

g. Show objects, such as vehicles, in relation to each other whenever possible.

h. Take photographs of approaches to the point of collision from the driver's eye-level.

i. Take a photograph at his eye-level from the point where an eye witness viewed the accident.

j. Photograph only that which played a part in the accident. Police officers, bystanders, and tow trucks should be excluded.

k. Place a ruler or measuring tape next to small objects before taking the photograph (fig. 118).

l. If the camera cannot be placed exactly at the desired point, move it further away from the scene, not closer to it.

m. Followup photographs taken at night, with daylight shots of the general location.

n. Obtain compass direction at the scene to provide identification of photos.

o. Take as many photographs as necessary to obtain the desired results. Usually four photographs are the minimum that should be taken (fig. 119).

3. Show What

The photographs taken at a traffic accident will probably be required to show—

a. Where vehicles came to rest.

b. Damage to vehicles to establish the angle of collision and movement in relation to each other while in contact.

c. Marks on the roadway.

d. Paths of the vehicles before and after collision.

e. Views of the drivers approaching the key point.

f. Traffic control devices.

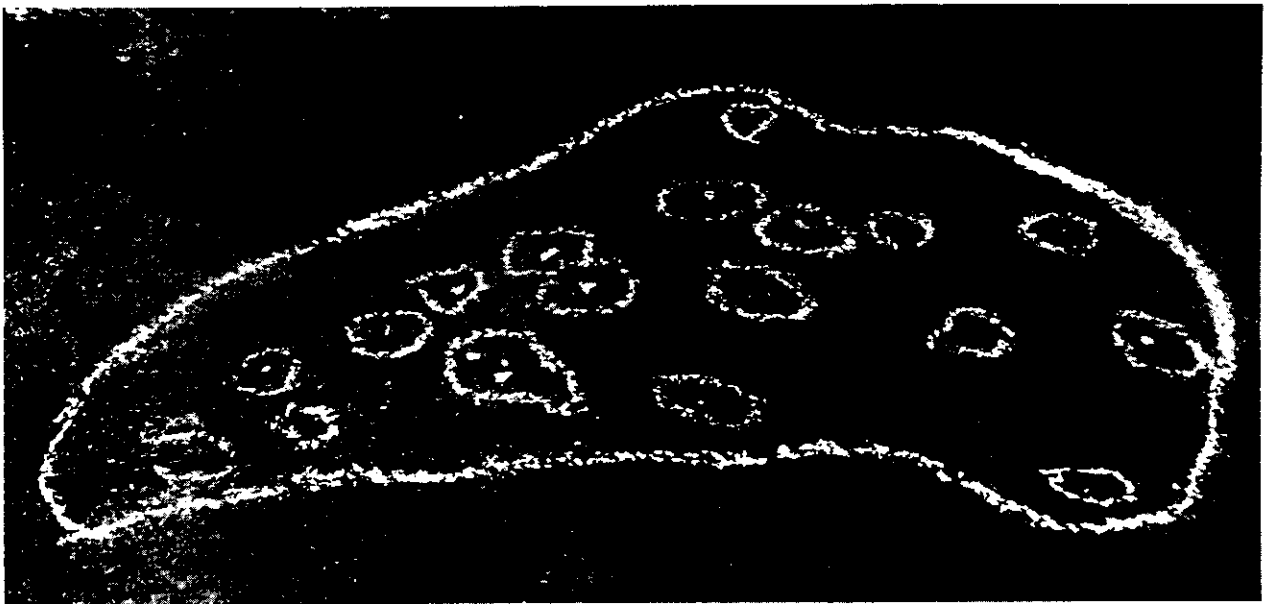
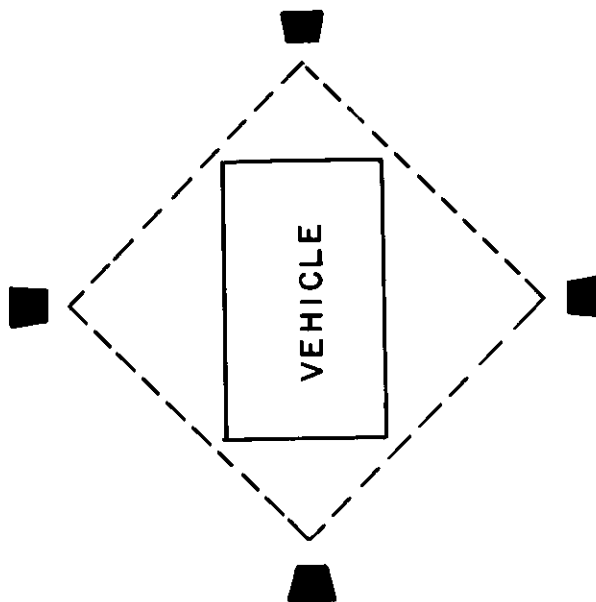


Figure 118. Example of a photograph of broken glass.



LEGEND

 Camera Position

Figure 119. Example of the minimum accident photographs.

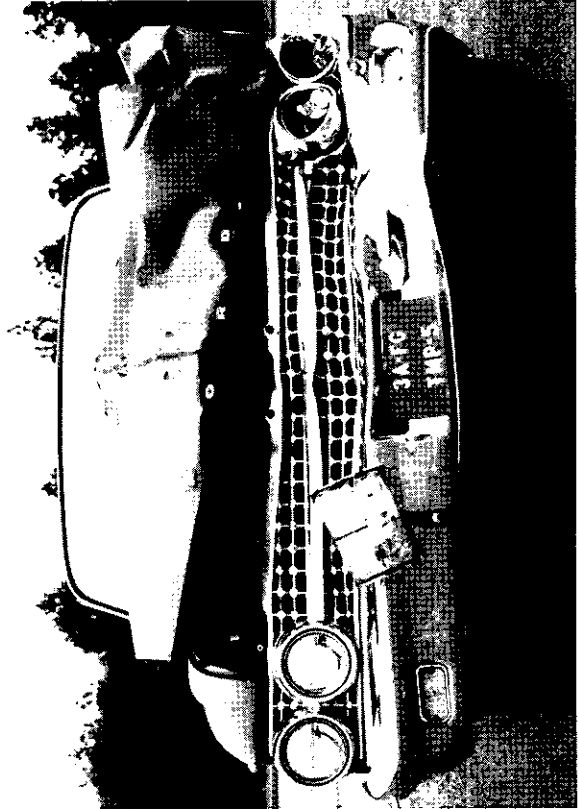
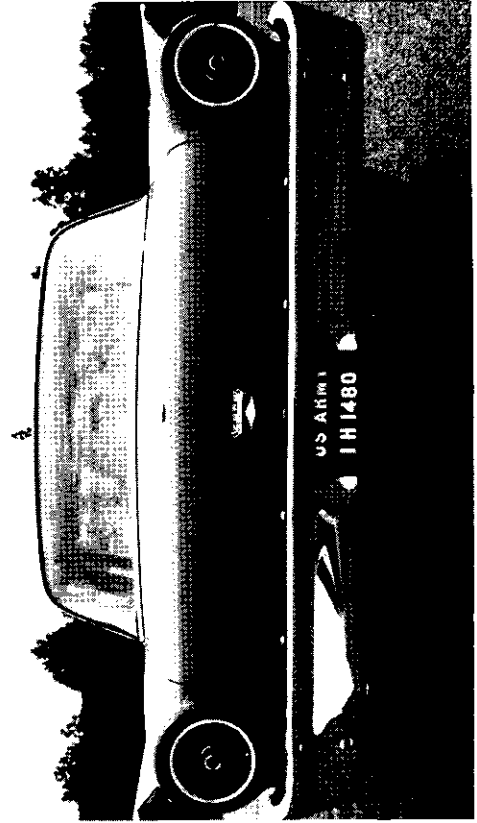
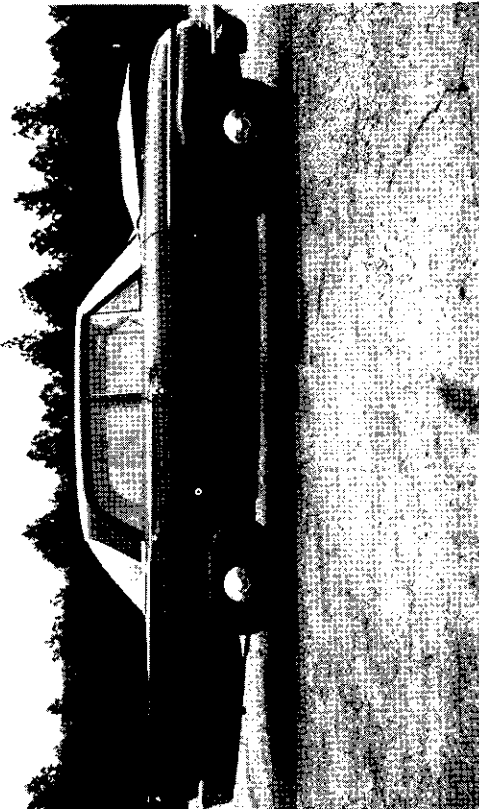
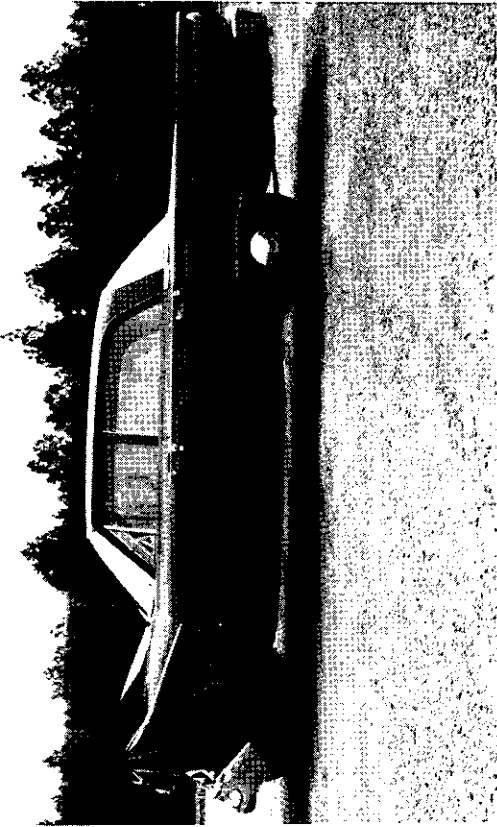


Figure 119—Continued.

APPENDIX VI

CURVES AND GRADIENTS

1. Methods of Measuring Curves

a. The radius of a short-radius curve may be estimated by using a cord to swing an arc. This method is shown in figure 120. The curve is staked as an arc of a circle by swinging an arc with tracing tape or cord from the experimentally determined center of a circle which is tangential to the relatively straight approaches to the curve being measured. The length of the tape cord from the center of the curve to its circumference is the radius of the curve. This method is practical for curves having a radius up to 250 feet and located on relatively level ground. In figures 120, 121, and 122: *CL* = centerline; *PC* = point of curvature; *PI* = point of intersection; *PT* = point of tangency.

b. The approximate radius of a curve may be determined by laying out right triangles (3:4:5 proportion) at the *PC* and *PT* locations as shown in figure 121. The intersection *O*, formed by extending the base legs of each triangle, represents the center of a circle. Therefore, the distance *R* from *O* to either the *PC* or the *PT* may be considered as the curve radius.

c. Another method for determining the radius of a curve is based on the formula—

$$\text{Radius} = C^2/8m + m/2 \text{ (fig. 122)}$$

Where: *C* = length of cord

m = perpendicular distance from center of the cord to (*CL*) of road.

R = Radius of the circle

Solving for *R* the above formula becomes—

$$R = C^2/8m + m/2$$

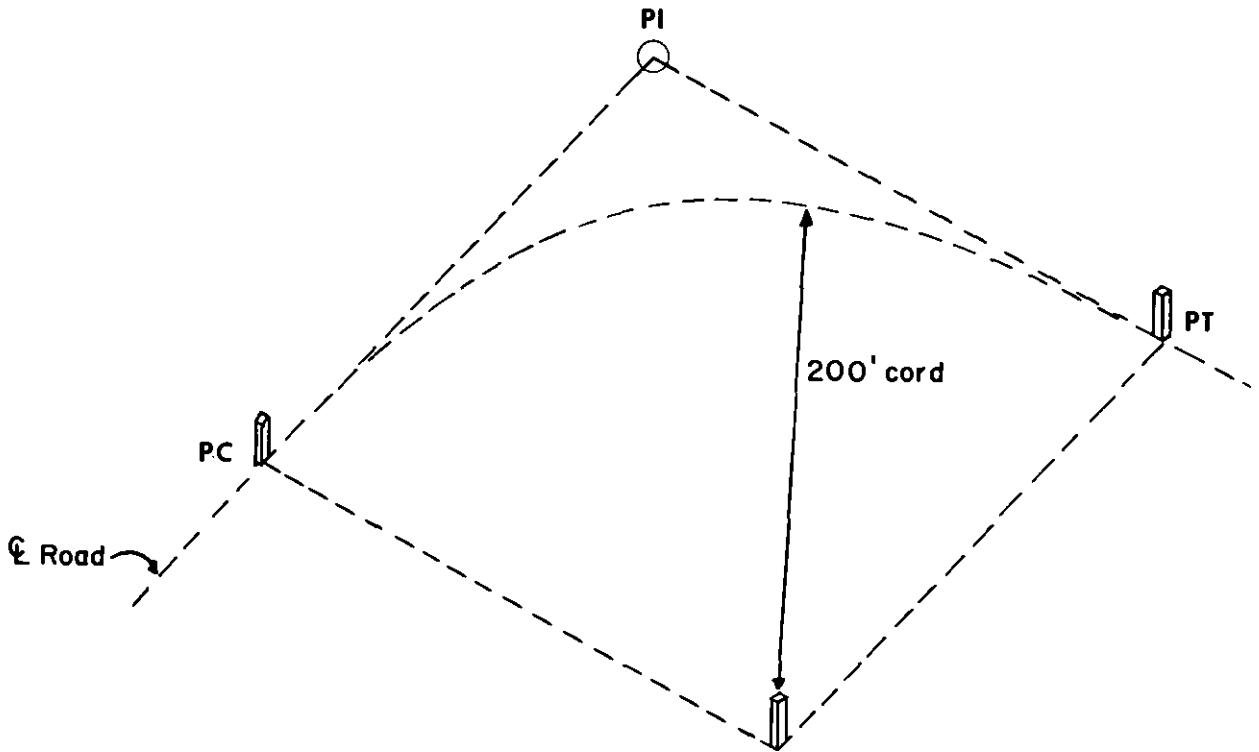


Figure 120. A curve staked by using a cord.

By fixing m at any convenient distance, such as 5 feet, the formula becomes—

$$R = C^2/40 + 2.5$$

In practical application of the formula, m is measured from the centerline of the curve toward the estimated center of the circle and then C is measured perpendicularly to m , making sure that C is centered on m . If C is measured to be 58 feet, then—

$$R = C^2/40 + 2.5, \text{ then}$$

$$R = 86.6 \text{ feet}$$

Note that when m is equal to 5 feet and R is equal to 100 feet, C must be equal to 62.44 feet. Thus, when measuring C , any value greater than 62.44 will give a value of R greater than 100 feet, and the curve therefore need not be reported.

2. Determining Road Gradient

a. Percent of slope (road gradient) can be determined by using the formula—

$$\frac{\text{Vertical distance}}{\text{Horizontal distance}}$$

$$\times 100 = \text{Percent of slope}$$

If a clinometer is available, percent of slope can be read directly.

b. When a clinometer is not available, the military policeman may use a carpenter's level, 5- or 10-foot board, approximately 1 foot wide, and a tape or ruler at least 3 feet long, graduated in inches.

- (1) Lay the board on the center of the road.
- (2) Place the level on the board.
- (3) Raise the board on the downward slope until it is level.

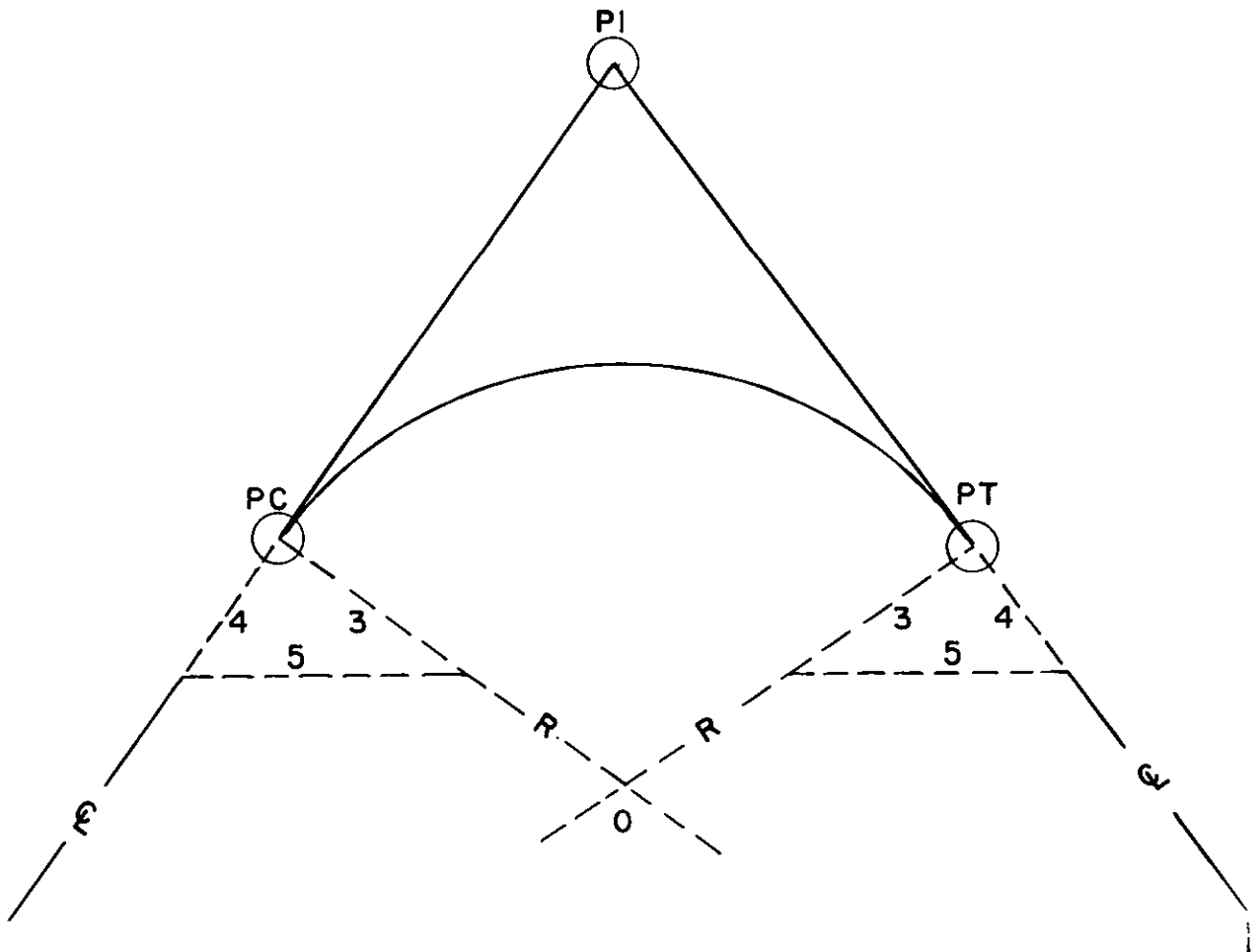


Figure 121. Curve radius by locating center of circle.

- (4) Measure the height of the elevated end of the board.
- (5) Represent the height off the ground of the board in inches as the numerator

- and the length of the board in inches as the denominator of a representative fraction of the grade.
- (6) Convert the fraction to a percentage.

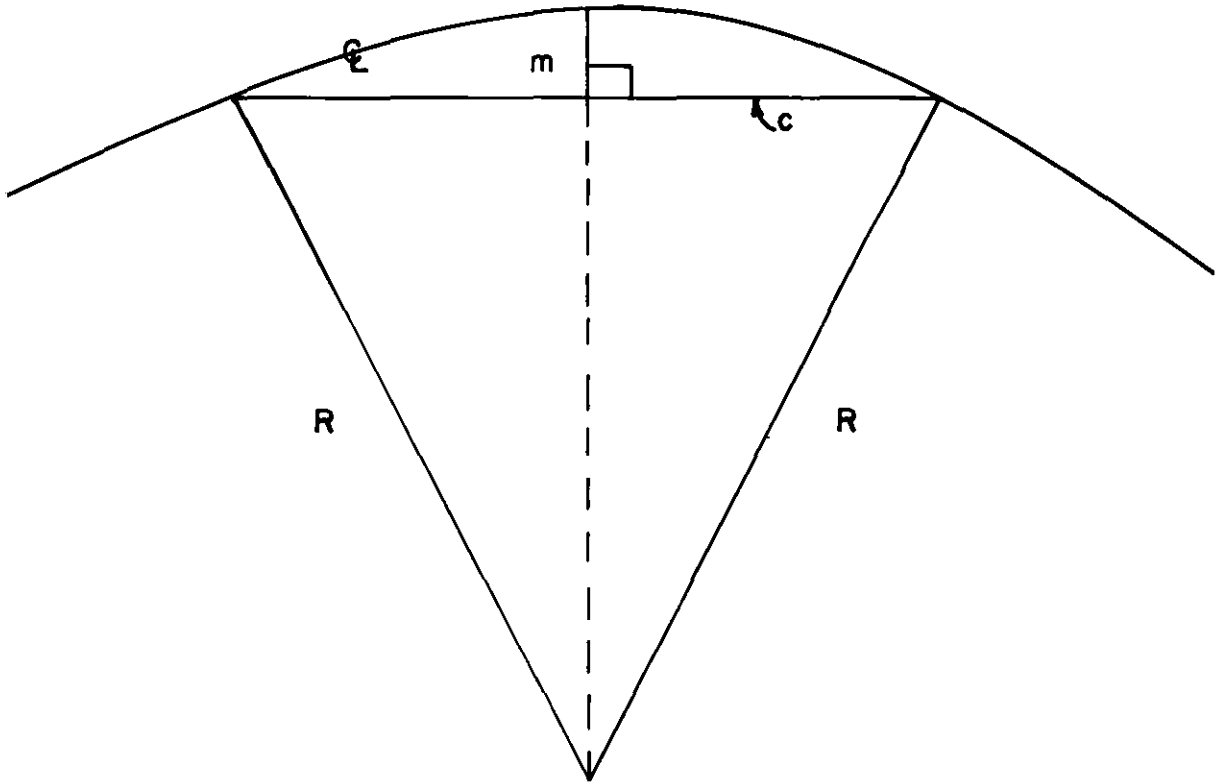


Figure 122. Measuring a curve using formula $R=C^2/8m + m/2$.

APPENDIX VII

TRAFFIC MAPS

1. General

Maps, used with overlays when appropriate, provide an excellent means of recording and portraying road information, information on terrain use, regulation concerning the road, and traffic control information.

2. Traffic Circulation Map

The main traffic circulation map is maintained by highway traffic headquarters. It is a graphic representation of the traffic circulation plan. The circulation map is normally composed of an issued map with one or more overlays portraying different parts of the information listed above. This map is not usually found below platoon headquarters. Information is extracted and passed on to the military policeman in the form of overlays. Much of the information found on this map, such as road information, originates with the individual military policeman.

3. The Traffic Control Map

This map is maintained by the military police unit and higher headquarters.

a. This map is composed of an issued map with overlays.

b. Information concerning traffic regulation and circulation necessary for control is portrayed on this map.

c. The locations of all military police traffic control positions and patrol areas are shown. Other military police positions should also be shown since they are a source of assistance during traffic control operations.

d. The location of highway regulating positions is shown.

e. The location of service facilities to aid in highway movement are also shown. This would include POL points, motor maintenance facilities, and medical service facilities, etc.

4. The Unit Location Map

This map/overlay combination shows the location of all units, facilities, and activities in an area. It is normally maintained at MP unit headquarters.

5. The Reconnaissance Map

This map or overlay is prepared by the military police who conduct a reconnaissance. A master reconnaissance map is maintained by the military police unit showing the results of reconnaissance in the area.

6. Traffic Control Team Map

a. The senior military policeman or noncommissioned officer in charge of a traffic control function will be equipped with a map/overlay that will portray a combination of information found on the maps discussed above. This information will be restricted to that affecting the area of responsibility of the traffic team and the area immediately bordering it. Information that applies throughout the area, such as light restriction, dispatch routes, etc., is not portrayed on this map/overlay.

b. Basic information included on the map/overlays issued to the military police traffic control team includes—

- (1) Traffic flow.
- (2) Traffic regulations.
- (3) MP positions, activities, and facilities.
- (4) Vehicle holding area.
- (5) Vehicle service facilities.

- (6) Military police communication positions.
- (7) Road restrictions and route classification.
- (8) Bridge classification and bypasses.
- (9) Division plans.
- (10) Location of units, installations, and facilities.

c. In addition to maps and overlays the military police teams are often provided with strip maps to be used in giving direction to the road user. This is normal under static conditions or during preplanned operations. Strip maps

are used for specific instructions to road users, such as direction to crossing sites, holding areas and supply complexes.

d. Another map or overlay that is often provided to the military policeman assigned to traffic functions is the "measle map" (fig. 123). This map or overlay assigns a reference number or letters to each intersection of importance. By use of this reference the military police can quickly report information concerning a location with a minimum of error possibility. A modification of the measle map may assign reference points to roads instead of intersections or it may be a modification of the artillery reference point system (FM 6-135).

MAP:FRANKFURT
1:100,000; SHEET:T-3

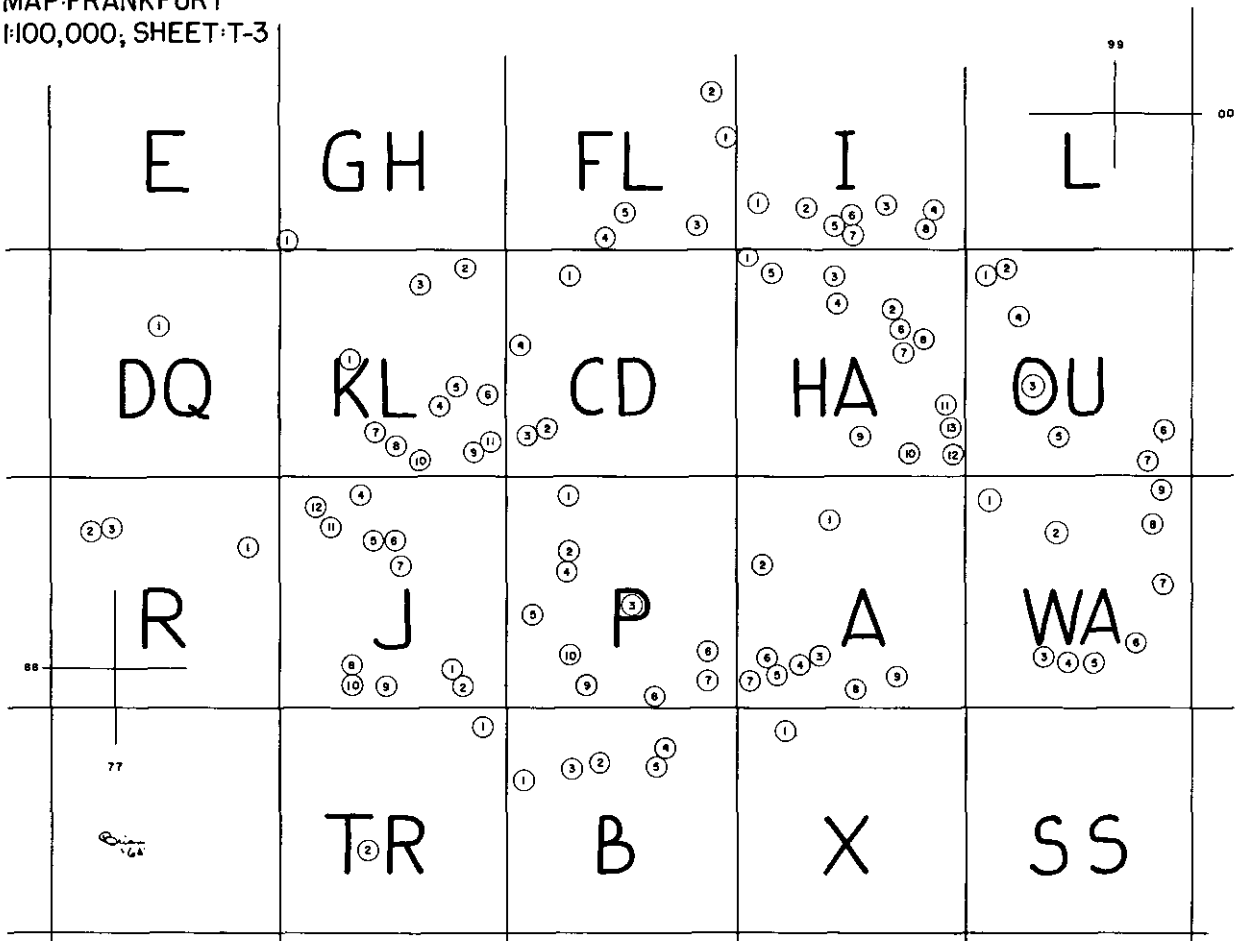


Figure 123. Example of a measle map overlay.

APPENDIX VIII

RECONNAISSANCE

1. Route Reconnaissance

a. A route reconnaissance report should be accurate, concise, and clear. The preferred method of preparation is in simplified map form (fig. 124) or overlay, using symbols (fig. 125) to show the limiting features. A route reconnaissance report is accompanied by a road reconnaissance report and bridge, tunnel, ferry, and ford reconnaissance reports as needed. Sketches of limiting features, local maps, and photographs of significant factors (terrain, roads, tunnels, bridges, ferries, fords, and so forth) support the route report.

b. Symbols for use in preparing a route reconnaissance report are listed below and also appear in figures 124 and 125.

- (1) Length (in kilometers) between well marked points may be shown.
- (2) Curves having radii of less than 30 meters with these radii marked in feet or meters (app. VI).
- (3) Steep grades with their maximum gradients in percent, and length of any grade of 7 percent or greater (app. VI).
- (4) Road width of constructions, with the widths of the traveled ways in meters; their lengths in kilometers.
- (5) Underpass limitations, with their limiting heights and widths in meters.
- (6) Bridge bypasses, classified as easy, difficult, or impossible (para. 3 below).
- (7) Civil or military road numbers, or other designations.
- (8) Feasibility of driving off roads, including shoulders.
- (9) Locations of fords and ferries, including limiting information.

c. Route classification formula, symbols for route reconnaissance maps or overlays are shown in figures 124 and 125. Further symbols are as follows:

(1) *Types of roads.*

- (a) (X) All-weather—Any road which, with reasonable maintenance, is passable throughout the year to a volume of traffic never appreciably less than its maximum good weather capacity. This type of road has a waterproof surface and is only slightly affected by rain, frost, thaw, or heat. At no time is it closed to traffic due to weather effects other than snow blockage. The following are examples of this category: concrete; bituminous; brick; or stone.
- (b) (Y) Limited all-weather—Any road which, with reasonable maintenance, can be kept open in bad weather to a volume of traffic which is considerably less than its normal good weather capacity. This type of road does not have a waterproof surface and is considerably affected by rain, frost, or thaw. The following are examples of this category: crushed rock or waterbound macadam; gravel or lightly metaled surface.
- (c) (Z) Fair weather—A road which becomes quickly impassable in bad weather and which cannot be kept open by normal maintenance. This type of road is seriously affected by rain, frost, or thaw. The following are examples of this type: natural or stabilized soil; sand or clay; cinders; disintegrated granite.

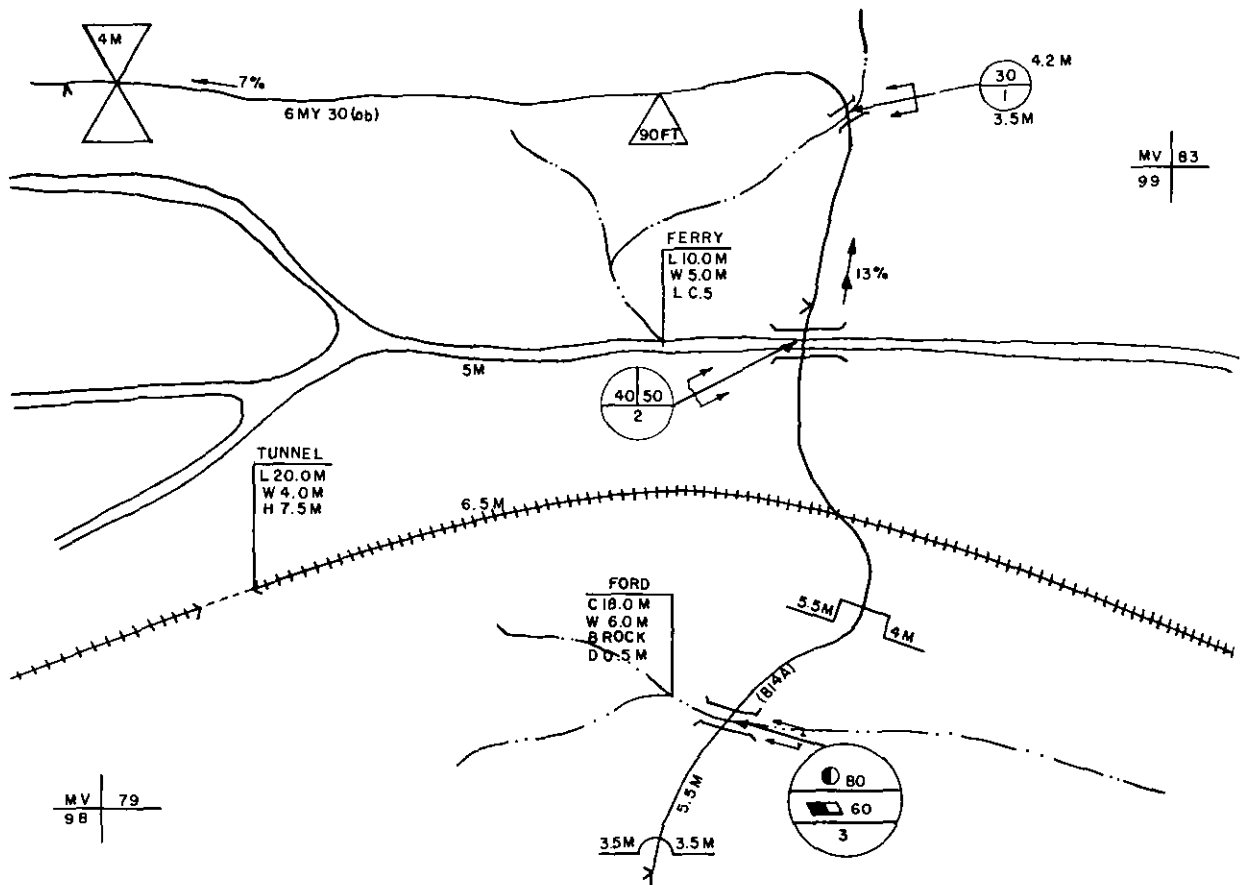


Figure 124. Example of route reconnaissance report.

(2) *Formulas.*

- (a) 20 feet Y 50 describes a route 20 feet wide (minimum), limited all-weather type, and load classification of class 50.
- (b) 20 feet Y 50 (Ob). "(Ob)" indicates an obstruction along the route.
- (c) 20 feet Y 50 (T). "(T)" represents snow blockage.
- (d) 20 feet Y 50 (W). "(W)" represents flooding.

(3) *Causeways, snowsheds, and galleries.*

Although these structures are not often encountered in a route reconnaissance, when they constitute an obstruction to traffic, they should be included in the route reconnaissance report. Limit the data to clearances and load carrying capacity. If possible, support the information with photographs or a sketch of each structure.

Also, include enough descriptive information to permit an evaluation concerning the strengthening or removal of these structures.

- (a) A causeway is a raised way across wet or unstable ground.
- (b) A snowshed is a shelter protecting something from snow, such as a long structure over an exposed part of a road or railroad.
- (c) A gallery is a sunken or cut passageway covered overhead as well as at the sides. In a combat area, a gallery may be important not only because it may be an obstruction, but because it may afford additional protection.

2. Road Reconnaissance

a. Information Required.

- (1) Local name of road.

FERRY LENGTH WIDTH LOAD CAPACITY		FORD LENGTH WIDTH BOTTOM DEPTH
TUNNEL LENGTH WIDTH VERT. CLEAR.		
		814A
00 100 100 000		11 11 11

- (1) Sharp Curve (radius in feet or meters)
- (2) Steep Grade (arrows point uphill) (grade in percent) (length of arrows may show length of grade when scale allows)
- (3) Constriction (width in meters)
- (4) Arch constriction (width on left & height on right in meters)
- (5) Underpass Constriction (width on left & height on right in feet or meters)
- (6) Bypass easy
- (7) Bypass difficult
- (8) Bypass impossible
- (9) Level crossing
- (10) Ford (length, width, bottom, and depth) Ferry (length, width, load capacity)
- (11) Tunnel (Shape, length, width, vertical clearance)
- (12) Road Block
- (13) Road Block (ready to use but not in position)
- (14) Proposed Road Block
- (15) Limits of Sector
- (16) Civil or Military Route Designation
- (17) Cover (woods) (deciduous—left) (evergreen—right) Arrow denotes possibility of driving off the road into deciduous cover.

Figure 125. Overlay symbols.

- (2) Local road designation and number.
- (3) Location of road by map grid reference.
- (4) Obstructions which include, among other items, underpasses, fords, large tree limbs, craters, projecting buildings, areas subject to inundation, and so forth.
- (5) Bridge locations. (Bridge reconnaissance is outlined in paragraph 3 below.)
- (6) Tunnel locations, together with their lengths, widths, and heights. (Tunnel reconnaissance is described in FM 5-36.)
- (7) Snowshed locations and estimated coverage.

HIGHWAYS

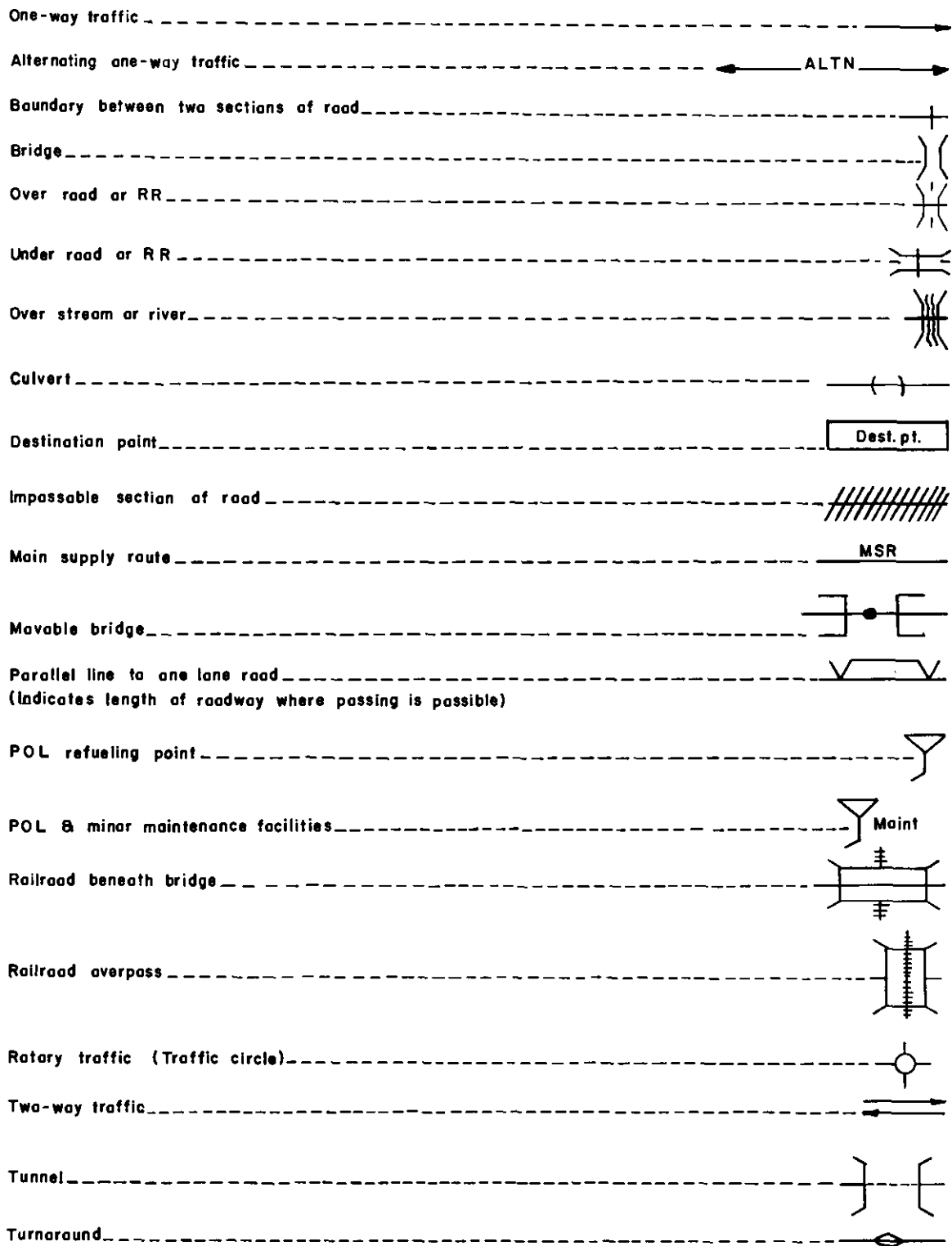


Figure 125—Continued.

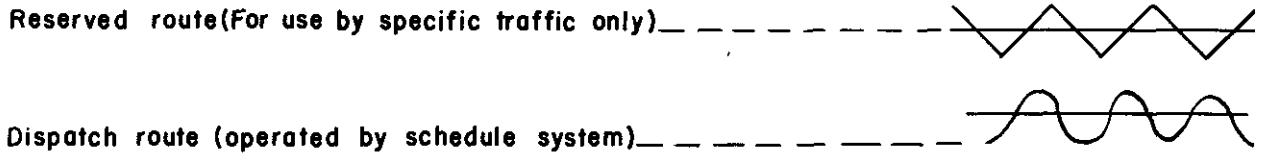


Figure 125—Continued.

- (8) Snow gallery locations, together with their lengths, widths, and heights.
- (9) Other requirements are listed in paragraph 1b above.

b. *Road Classification Formula.* Road characteristics are expressed by definition and symbols in the following order: limiting factors, width, construction material, and, if desired, length.

- (1) *Limiting factors.* The symbol A is used if there are no limiting factors. The symbol B means one or more limiting factors. A question mark in parentheses (?) means an unknown limiting factor. A V-like symbol on a map or overlay represents the terminal points of the road sector (fig. 124). Figure 126 shows limiting factors, their criteria, and symbols representing them.
- (2) *Width.* The traveled way of a road is expressed in feet or meters followed

by a slash, with the width of traveled way and shoulders combined, as 14/16.

- (3) *Construction materials.* See figure 127 for these symbols.
- (4) *Length.* This may be shown, if desired, in parentheses at the end of a road classification formula.
- (5) *Examples.*
 - (a) A 5.0/6.2 mk—concrete road, 5.0 meters wide. 6.2 meters, including shoulders; no limiting factors.
 - (b) Bgs 14/16 ft 1 (Ob)—gravel or lightly metaled 14 feet wide, 16 feet including shoulders, steep gradients; rough surface; and obstructions.
 - (c) Bc (F ?) 3.2/4.8 mp (4.3 km) T—paving brick or stone. 3.2 meters wide. 4.8 meters, including shoulders; sharp curves, foundation unknown, 4.3 kilometers long; and subject to snow blockage.

Limiting factor	Criteria	Symbol
Sharp curves	Sharp curves with radius less than 10 ft (30 m) cause some slowing of convoy traffic and will in addition be reported as obstructions.	c
Steep gradients	Steep gradients, 7% or steeper, cause some slowing of convoy traffic. Gradients steeper than 7% and excessive changes in gradients will, also be reported as obstructions.	g
Poor drainage	Inadequate ditches, crown/comber, or culverts; culverts and ditches blocked or otherwise in poor condition.	d
Weak foundations	Unstable, loose or easily displaced material.	f
Rough surface	Bumpy, rutted, or potholed to an extent likely to reduce convoy speeds.	a
Excessive comber or superelevation	Falling away so sharply as to cause heavy vehicles to skid or drag toward the roadside.	i

Figure 126. Criteria for determination of limiting factors.

Symbol	Material	Normal road type
k	Concrete -----	Type (X); generally heavy duty
kb	Bituminous or asphaltic concrete (bituminous plant mix).	Type (X); generally heavy duty
p	Paving brick or stone-----	Type (X); generally heavy duty
rb	Bitumen-penetrated macadam; waterbound macadam with superficial asphalt or tar cover.	Type (X) or (Y); generally medium duty
r	Waterbound macadam, crushed rock, or coral-----	Type (Y); generally light duty
l	Gravel or lightly metaled surface-----	Type (Y); generally light duty
nb	Bituminous surface treatment on natural earth, stablized soil, sand-clay, or other select material.	Type (Y) or (Z); generally light duty
n	Natural earth, stablized soil, sand-clay, shells, cinders, disintegrated granite, or other select material.	Type (Z); generally light duty
v	Various other types not mentioned above-----	(Indicate length when this symbol is used)

Note. In addition to the symbols shown above, the symbol "b" (bituminous surface) may be used alone when the type of bituminous construction cannot be determined.

Figure 127. Symbols for types of surface materials.

Dimension data	Simple stringer	Slab	T-beam	Truss	Girder	Arch	Suspension
Overall length-----	X	X	X	X	X	X	X
No. of spans-----	X	X	X	X	X	X	X
Length of spans-----	X	X	X	X	X	X	X
Panel length-----				X			X
Height above streambed-----	X	X	X	X	X	X	X
Height above estimated normal water level-----	X	X	X	X	X	X	X
Width of roadway-----	X	X	X	X	X	X	X
Vertical clearance (over)-----				X			X
Horizontal clearance-----	X	X	X	X	X	X	X

Note. The letter X indicates that the dimension is required.

Figure 128. General dimension data required for each of the seven basic types of bridges.

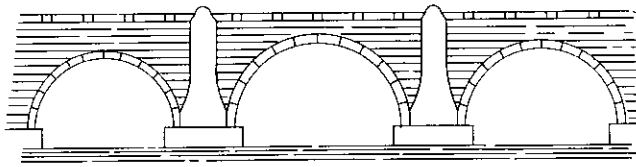
Capacity ¹ dimension data	Basic types of bridge										
	Simple stringers					Slab	T-beam	Truss	Girder	Arch	Suspension
	Timber		Steel								
	Rectang	Log	I-Beam	Channel	Rail						
Thickness of wearing surface.....			X			X		X	X		X
Thickness of flooring, deck, or depth of fill at crown.....			X			X		X	X		X
Distance, c-to-c, between T-beams, stringers, or floor beams.....			X	X		X		X	X		X
No. of T-beams or stringers.....			X	X		X		X	X		X
Depth of each T-beam or stringer.....			X	X		X		X	X		X
Width of each T-beam or stringer.....			X	(²)		X		X	X		X
Thickness of web of I-beams, WF-beams, channels, or rails.....			X	X		X		X	X		X
Sag of cable.....											
No. of each size of cable.....											
Thickness of arch ring.....									X		X
Rise of arch.....									X		X
Diameter of each size of cable.....											
Depth of plate girder.....											
Width of flange plates.....									X		X
Thickness of flange plates.....									X		X
No. of flange plates.....									X		X
Depth of flange angle.....									X		X
Width of flange angle.....									X		X
Thickness of flange angle.....									X		X
Depth of web plate.....									X		X
Thickness of web plate.....									X		X
Average thickness of flange.....									X		X

1 Capacity is computed by the use of formulas and data in bridge manuals.

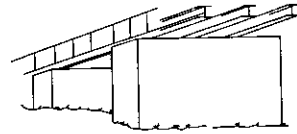
2 Diameter.

3 Width of flange.

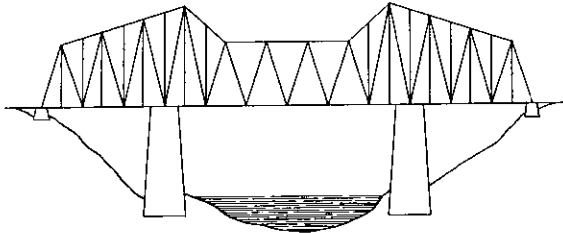
Figure 129. Capacity dimension data required for each of the seven basic types of bridges



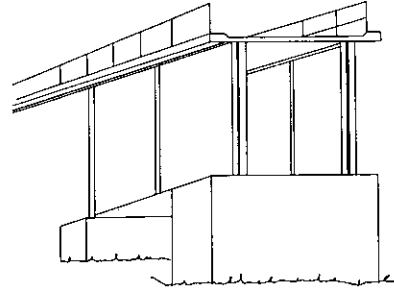
(CLOSED SPANDREL)



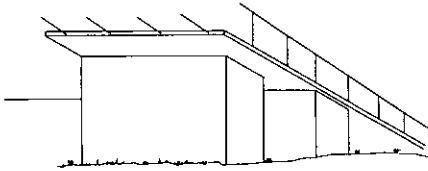
STEEL STRINGER



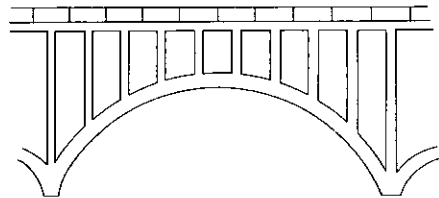
CANTILEVER



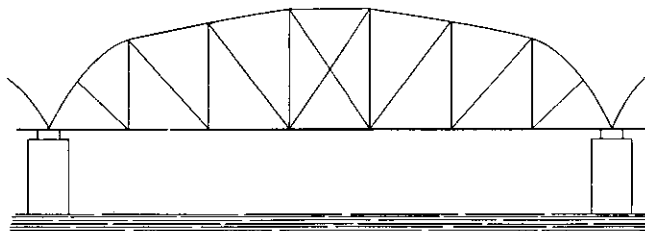
GIRDER



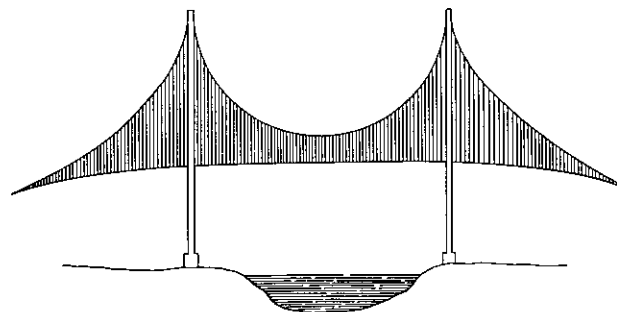
SLAB



ARCH (OPEN SPANDREL)



TRUSS



SUSPENSION

Figure 130. Bridge type and material symbols.

Bridge Number Symbols

Construction Material Symbols

<i>Type of span</i>	<i>Number symbol</i>	<i>Material of span construction</i>	<i>Letter symbol</i>
Truss -----	1		
Girder -----	2		
Beam -----	3	Steel, or other metal -----	a
Slab -----	4	Concrete -----	k
Arch (closed spandrel) -----	5	Reinforced concrete -----	ak
Arch (open spandrel) -----	6	Prestressed concrete -----	kk
Suspension -----	7	Stone or brick -----	p
Floating -----	8	Wood -----	n
Others -----	9		

Figure 130—Continued.

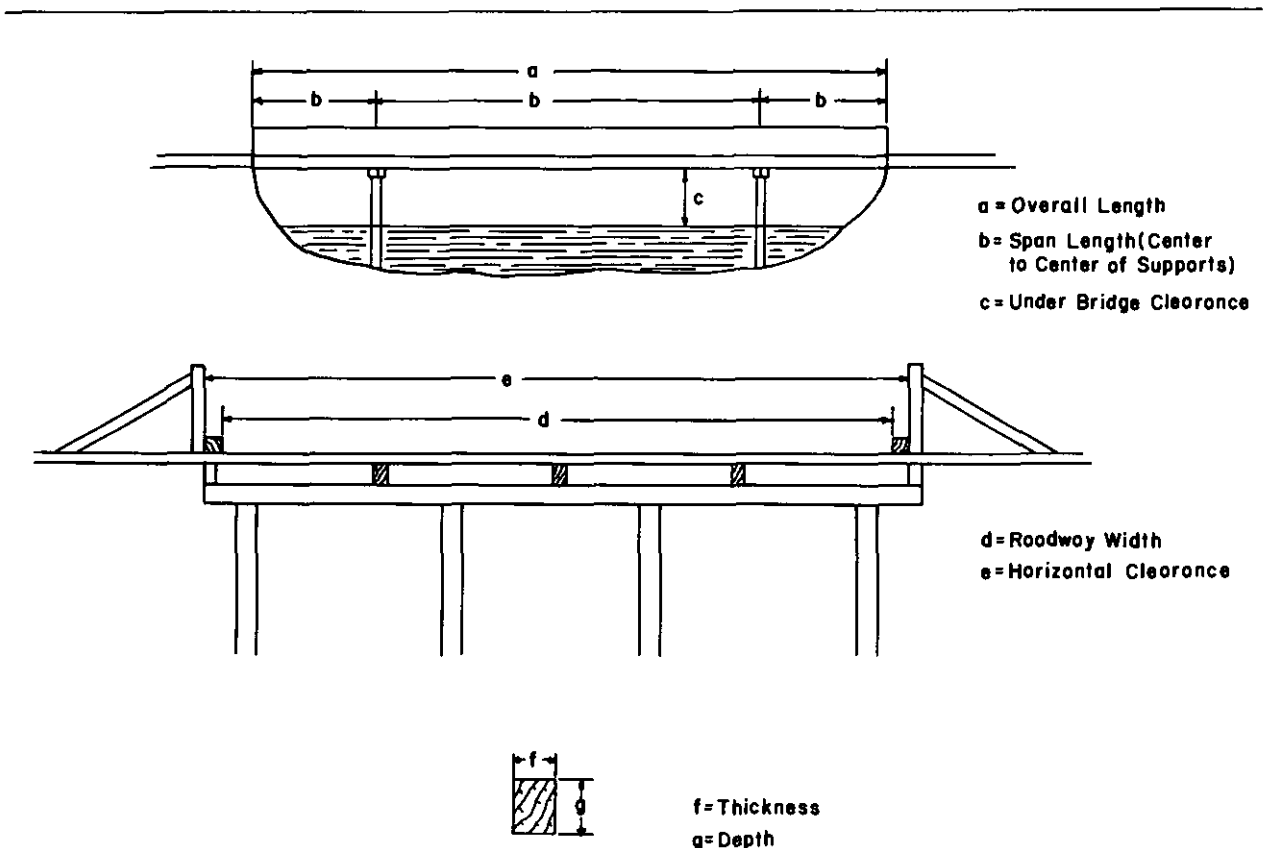


Figure 131. Typical timber cross section

3. Bridge Reconnaissance

a. The limiting features of bridges are of basic importance to the selection of a route for normal troop movement (figs. 128 and 129).

b. Bridge reconnaissance may be made using two different methods.

- (1) Hasty reconnaissance determines immediate trafficability.
- (2) Deliberate reconnaissance is done when there is enough time and qualified personnel to make a thorough analysis and classification of the bridge, including necessary repairs or demolition procedures.

c. Full bridge symbol includes the location of the bridge, the arbitrarily assigned bridge number, the military local classification number, the overall length of the bridge, the roadway width, the vertical clearance, and the bridge bypasses. Horizontal clearance, under-bridge clearance, number of spans, type of span construction, type of span construction material, and length and condition of spans (figs. 130 and 131).

d. Bridge bypasses are local detours, which are classified as easy, difficult, or impassable. Figure 125 shows the symbols used for each classification.

- (1) Bypass easy is a local detour by road or cross-country movement which all types of traffic can make in 15 minutes or less, or 4 miles (6.5 km) added to the direct route distance. It should require less than 4 hours for 35 men, with proper equipment, to improve or construct.
- (2) Bypass difficult differs from bypass easy in that more than 4 hours are required for 35 men, with proper equipment, to improve or to construct.
- (3) Bypass impossible exists when—
 - (a) No alternative bridge is available within acceptable distance.

- (b) Terrain prevents off-road movement or temporary road construction.
- (c) Characteristics of the stream prohibit fording or construction of temporary crossing means.
- (d) Depth or slope of obstacle prohibits construction of approaches to crossing site.

e. To report a bridge reconnaissance, see FM 5-36.

4. Ford Reconnaissance

a. *Classification of Fords.* Fords are classified according to their crossing potential for foot, wheeled, or tracked movement.

- (1) Their trafficability is indicated for vehicles and foot troops as shown in figure 132.
- (2) Approaches may be paved with concrete or bituminous material, although they are usually just sand or gravel. The composition and slope of the approach are important; its trafficability in inclement weather depends upon these factors.
- (3) The composition of the stream bottom determines its passability. It is important, therefore, to indicate it.
- (4) The stream bottom of a ford has been paved, in some cases, to improve its load-bearing capacity and to reduce the stream's depth. The paved area may be of concrete, gravel, layers of sandbags, steel mats, or wooden planks.
- (5) Seasonal floods, excessively dry periods, freezing, and other extreme conditions of weather affect the fordability of a stream.

Type of traffic	Fordable depth, m ¹	Min width, m	Type of bottom	Max desirable slope on approaches ²
Foot -----	1	1—(single file) 2—(column of 3's)	Firm enough to prevent sinking	1:1
Trucks and truck-drawn artillery_	.6	3.6	Firm and smooth	3:1
Light tank -----	.3 to 1	4.2	do.	2:1
Medium tanks -----	.6 to 1.2	4.2	do.	2:1
Heavy tanks -----	1.2 to 1.8	4.2	do.	2:1

¹ Moderate current.

² Based on hard, dry surface. If wet and slippery, slope must be less.

Figure 132. Trafficability of fords.

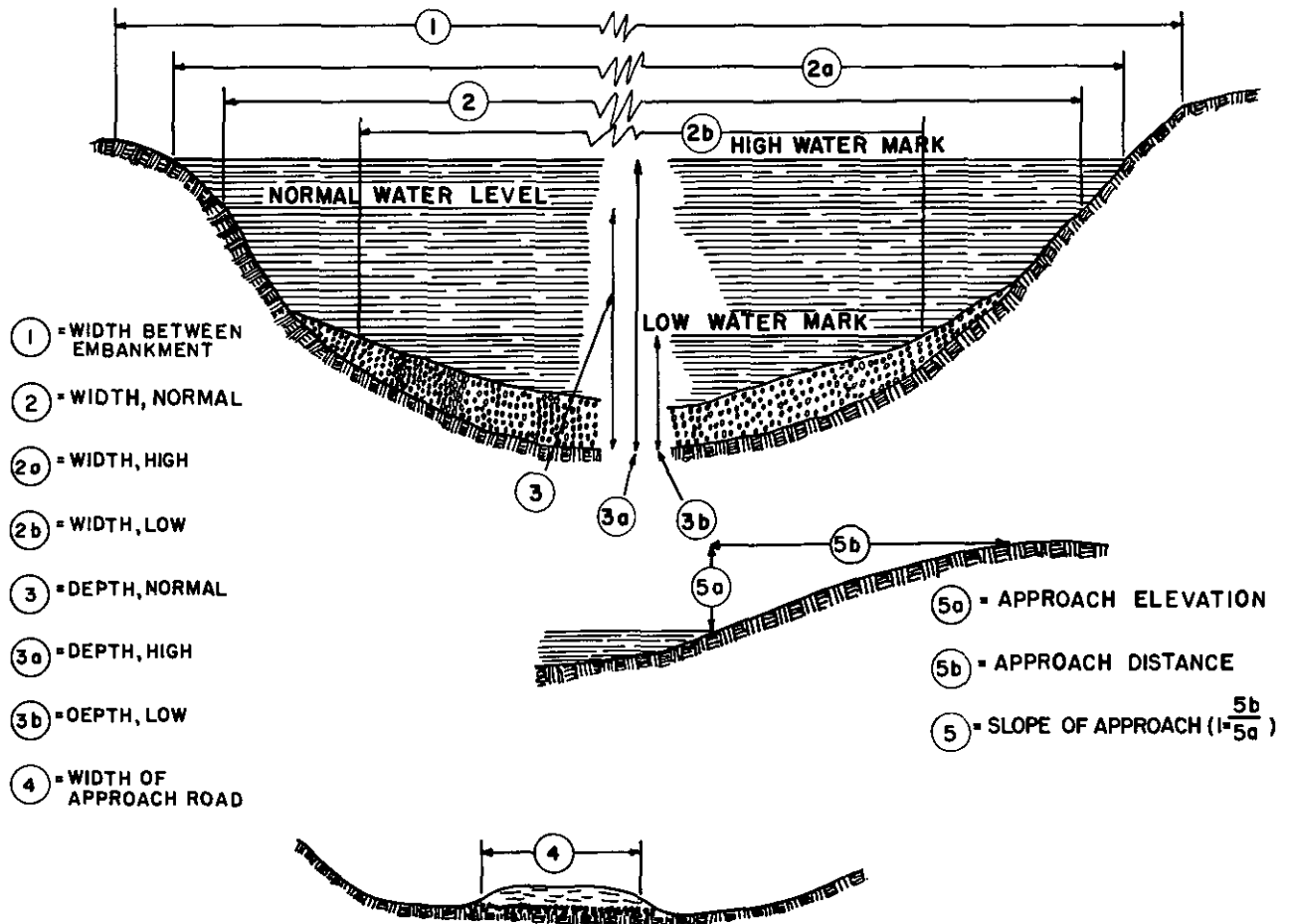


Figure 133. Standard dimensional data for fords.

(6) Swiftness of the current and the presence of debris affect passability of a ford. Current is recorded as swift (over 1.5 meters per second), moderate (1 to 1.5 meters per second), or slow (less than 1 meter per second).

(7) Dimensional data of a ford are pointed out in figure 133.

b. Stream Width.

(1) With a compass, determine the azimuth from a point on the near shore close to the water's edge to a point near the water's edge on the far shore of the stream directly opposite. Then another point, either upstream or downstream from the previously

marked points, is established on the near shore, from which the azimuth to the point on the far shore is 45° at variance with the previously marked azimuth. The distance between the two points on the near shore is equal to the distance across the stream (fig. 134).

(2) Stretch a string across the stream, then measure the distance on the string. A measuring tape may be used if one long enough is available.

c. Stream Velocity. Stream velocity is calculated by measuring a distance along the riverbank, then determining the time it takes a light object to float this measured distance (fig. 134). Velocity is computed as follows:

$$\frac{\text{Measured distance (m)}}{\text{Time (sec)}} = \text{velocity in meters per second}$$

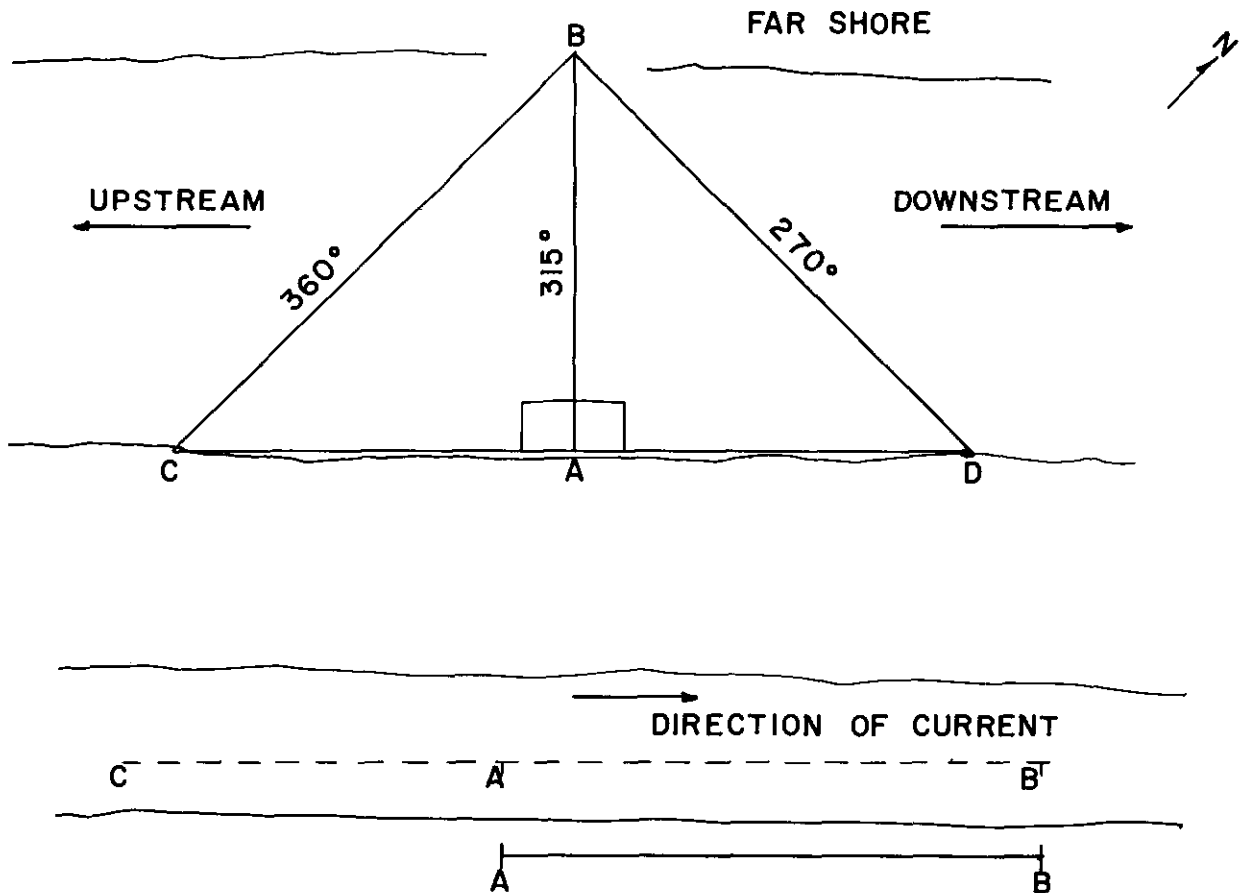


Figure 134. Methods of measuring stream width and velocity.

5. Ferry Reconnaissance

Ferries actually differ widely in appearance, capacity, propulsion, construction, and so on.

For information on ferry reconnaissance, see FM 5-36.

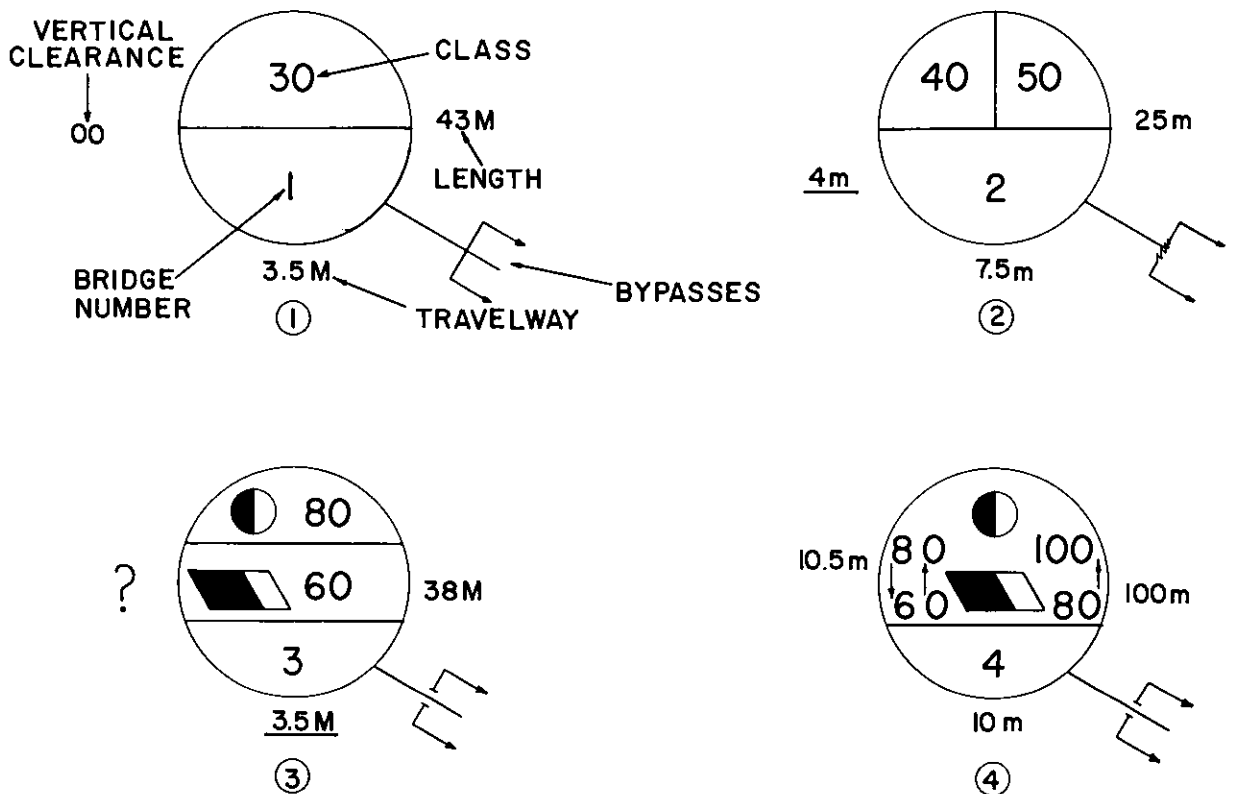


Figure 185. Examples of the full bridge symbol for use on a map or overlay.

APPENDIX IX

NATO ROAD NETWORK—DEFINITIONS AND CHARACTERISTICS

(STANAG 2151, 16 October 1963)

Section I. DEFINITIONS

1. The Basic Military Road Network

a. The basic military road network includes all routes designated in peacetime by the host nations to meet the anticipated military movements and transport requirements, both allied and national.

b. The basic network should already, in peacetime, have sufficient capacity and be equipped with the necessary facilities.

2. A Military Road Maneuver Network

a. A military road maneuver network is the road system required by a commander for the conduct of a specific operation and for the required logistical support for that operation.

b. It is built up from the corresponding basic military road network, the routes of which form the framework of the military maneuver nets, taking into consideration such additions or alternatives as may be required by circumstances and the needs of the command. This network is defined and controlled (allotment of movement credits) by the military authorities, national or allied, according to the breakdown of responsibilities in the theatre of operations (communication zone, rear and forward combat zones).

3. Axial Routes

Axial routes. This term denotes the routes running through the rear area and into the forward area. They are identified by odd numbers and shown on overlays by unbroken lines.

4. Lateral Routes

Lateral routes. This term denotes the routes, the general direction of which is roughly

parallel to the *frontline*, which feed into or cross axial routes. They are identified by even numbers and shown on overlays by broken lines.

5. Traffic Flow

Traffic flow is the total number of vehicles passing a given point in a given time. Traffic flow is expressed as vehicles per hour (V.P.H.).

6. Road Capacity in Vehicles or Tons

Road capacity in vehicles or tons. The road traffic which may use a road is variable. The maximum capacity either for the flow of vehicles or for the tonnages carried are important data for transportation planning. These maxima are defined below:

a. The road capacity in vehicles is the maximum number of vehicles that can pass over a particular road or route in the same direction within a given time. It is generally expressed in vehicles per hour (V.P.H.). The road capacity cannot be greater than the maximum traffic flow at its most restricted point.

b. The road capacity in tons is the maximum number of tons which can be moved over a particular road or route in the same direction within a given time. It is generally expressed in tons per hour and is the product of V.P.H. and the average payload of the vehicles using the route (e.g. 200 V.P.H. \times 3 T. = 600 tons per hour).

c. Complementary remarks. Estimates of traffic flows and/or tonnage capacity should take into account the existing conditions. They may include—

- (1) Road characteristics (terrain, type of roadway, number of lanes available,

road maintenance, rated tonnage capacity of the weakest bridge).

- (2) Military traffic regulations (density, speed limits, direction of traffic).
- (3) Types of vehicles employed.
- (4) Movement conditions (by day, by night, lighting and/or weather conditions).

7. A Controlled Route

A controlled route denotes a route the use of which is subject to traffic or movement restrictions ("Movement Credit" mentioned below is defined in STANAG 2154.) (Also see para. 19 and 20 below.)

a. A supervised route is a roadway over which control is exercised by a traffic control authority by means of traffic control posts, traffic patrols or both. A "Movement Credit" (STANAG 2154) is required for its use by a column of 10 or more vehicles or by any vehicle of exceptional size or weight.

b. A dispatch route is a roadway over which full control, both as to priorities of use and the regulation of movement of traffic in time and space is exercised. A "Movement Credit" is required for its use by any independent vehicle or group of vehicles regardless of number or type.

c. A reserved route is a controlled route the use of which is—

- (1) Allocated exclusively to a particular authority or formation, e.g., route reserved for the 10th Division, or
- (2) Intended to meet a particular requirement, e.g., route reserved for evacuation.

8. An Open Route

An open route is a route for the use of which no "Movement Credit" is required.

9. A One Way Road

A one way road is a road on which vehicles may move in one direction only at a particular time.

10. A Signed Route

A signed route is a route of one of the above categories along which a unit has placed, on its own initiative, for its exclusive use, and under the conditions prescribed by the command or the maneuver regulations, directional signs which include the identification symbol of the unit concerned.

11. Route Where Guides are Provided

Route where guides are provided. This term denotes a route included in one of the above categories on which a unit has placed, under its own initiative and for its exclusive use and under the conditions prescribed by the command or the maneuver regulations, guides responsible for showing the vehicles of that unit the direction they are to follow: These guides direct the personnel and vehicles of their own formation but do not give any indication to personnel and vehicles of other units who must respect the common signing and regulations.

12. Prohibited Route

Prohibited route or prohibited section of route is a route or section of route over which traffic is prohibited, whatever its nature.

Section II. CHARACTERISTICS

13. Route

The characteristics of a route are in particular:

- a.* The width of the traveled way.
- b.* The clearance of obstacles (e.g., tunnels, bridges, etc.).

c. The class of loads which can be accepted in accordance with STANAG 2021 (Edition No. 2).

14. Widths

a. The various widths of a road are illustrated in STANAG 2151.

b. The number of lanes is determined by the width of the traveled way; i.e., the subdivision of the traveled way to allow the movement of a single line of vehicles. Taking into account the width of a normal vehicle and the space required on either side of that vehicle, the width of the lane required for the movement of one column is normally estimated at 3.50m (11½ feet) and 4m (13 feet) for a tracked combat vehicle. A single lane road can only be used in one direction at any one time.

c. The traffic flow is determined by the number of lanes.

- (1) A route or road is *single flow* when it allows a column of vehicles to proceed and, in addition, isolated vehicles to overtake or to pass in the opposite direction, at predetermined points. It is desirable that the width of a single flow road be equal to at least 1½ lanes.
- (2) A route or road is *double flow* when it allows two columns of vehicles to proceed **simultaneously**. It is **essential** that the width of a double flow road be equal at least to 2 lanes.

Traffic flow possibilities	Road widths for normal vehicles only	Road widths for tracked combat vehicles
Isolated vehicles of appropriate width only and in one direction only.	At least 11½ ft., (3.50m)	At least 13 ft., (4m)
Generally one way only; no overtaking or passing in opposite direction.	Between 11½ ft., and 18 ft. (3.50m and 5.50m)	Between 13 ft., and 19½ ft., (4m and 6m)
Single flow -----	Between 18 ft., and 23 ft. (5.50m and 7m)	Between 19½ ft., and 26 ft., (6m and 8m)
Double flow -----	Over 23 feet (7m)	Over 26 ft. (8m)

Figure 136. Traffic flow.

d. In the light of the above definition, the traffic possibilities can be shown in figure 136.

15. Height

The height allowed for clearing overhead obstacles is that which separates the traveled way from a line drawn horizontally under the summit of the overhead obstacle. It is a definite limit prohibiting the use of a route to all vehicles which exceed that height, with or without a load.

16. Class

a. *Route*. The class of a route is fixed in relation to the heaviest gross weight vehicle the route will accept. (See STANAG 2021 (Edition No. 2).)

b. *Network*. The class of a network is fixed in relation to the minimum route classification in that network.

17. Categories

To facilitate movement those routes included in a low class network but over which heavier equipment can be moved are regrouped in broad categories:

Average traffic routes:	Class 50
Heavy traffic routes:	Class 80
Very heavy traffic routes:	Class 120

18. Composition of the Military Road Network

Whenever possible, the basic military road network is composed of average routes (Class 50) and includes a certain number of heavy traffic routes and few very heavy traffic routes.

Section III. MOVEMENT CONTROL

19. Movement Credit (STANAG 2154)

a. A movement credit is the time allocated to one or more vehicles to move over a supervised, dispatch or reserved route. It includes the indication of time at which the first and last vehicle of the columns are scheduled to pass:

- (1) The entry point, i.e., the point where the column enters the controlled route.
- (2) The exit point, i.e., the point where the column leaves the controlled route.

b. Identification of columns and movement credit.

- (1) Each column will be identified in accordance with STANAG 2027, i.e., blue flag on leading vehicle, green flag on last vehicle. In addition, when movement is being carried out at night, the commander (driver) of the leading vehicle will carry a torch giving a blue light and the commander (driver) of the last vehicle a torch giving a green light.
- (2) Additionally, each column will be identified by a number known as "*movement number*" or "*identification serial number*" which is allocated at the same time as the "movement credit" by the authority organizing the movement. This number will identify the column during the whole of the movement.
- (3) The number will be placed on both sides and, if possible, on the front of the lead vehicle and last vehicle of the column so as to be clearly visible. It will be composed of—

- (a) Two figures indicating the day of the month on which the movement is due to commence.
- (b) Three or four letters indicating the authority organizing the movement. The first two letters will be the national symbols shown in STANAG 1059 (Edition No. 2).
- (c) Two figures indicating the serial number allocated by the authority responsible for the movement. (Example: Identification 03-BEA-08 will indicate that Column No. 8 will be moved by a Belgian authority on the 3d day of the current month.)
- (d) The elements of a column may be identified by adding a letter behind the movement number.

20. Armbands for Movement Control Personnel (Not Traffic Control) (STANAG 2159)

a. The NATO Armed Forces agree that distinguishing armbands shall be used to identify all Movement Control Personnel who come into personal contact with forces being moved by road, rail, air, or any other agency.

b. It is agreed that the armband will be red, approximately 16½ inches (42cm) long and 3½ inches (9cm) wide, with a yellow wheel with eight spokes, 3 inches (7.5cm) in diameter. It will normally be fastened by four hooks or dome fasteners, 1 inch (2.5cm) apart.

c. The standard armband will be worn on duty in accordance with the uniform regulations of the country concerned but in such a way that the wheel can be clearly seen. Staff Officers may wear normal Staff Armbands if that is the usual practice of the countries concerned.

APPENDIX X

MOTOR VEHICLE EXAMINATION PROCEDURE

The following procedure may be used by military police to effect systematic examinations of motor vehicles. While primarily prepared for investigation of hit and run accidents this procedure is adaptable for all investigation involving an examination of a motor vehicle.

1. Record Location, Date, and Time of Estimation

2. Examine Exterior Surfaces

Search for fragments of clothing, fibers, hair, blood, tissue, marks in paint, paint from victim's vehicle, dust or grease, impressions of fabric, marks made by victim's clothing or vehicle, and fingerprints of victim (if victim may have touched hit-and-run vehicle).

a. Examine systematically, checking each portion in the following order (fig. 137).

- (1) *Front.*
- (2) *Left side.*
- (3) *Right side.*

- (4) *Rear.*
- (5) *Top.*
- (6) *Underneath.*

b. Check the following:

- (1) *License plates.* Were securing bolts and nuts recently replaced? Is license data the same as reported by victim or witnesses?
- (2) *Engine or radiator.* Warm?
- (3) *Grille, radiator ornament, and radiator (core and shell).* Breaks? Fractures? Bent parts? Parts missing? Adhering foreign substances, such as fabric or blood?
- (4) *Tire.* Evidence of recent skidding? Bent rims? Note location. Record make and tread pattern of each tire, noting location: right front, left front, etc.
- (5) *Door handles, bumpers and bumper guards, hinges, and other protruding*

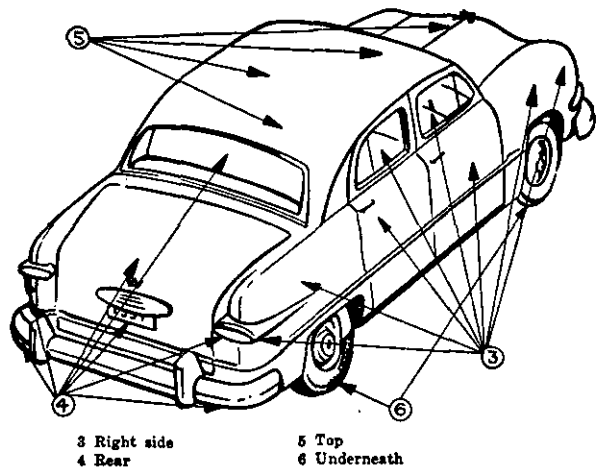
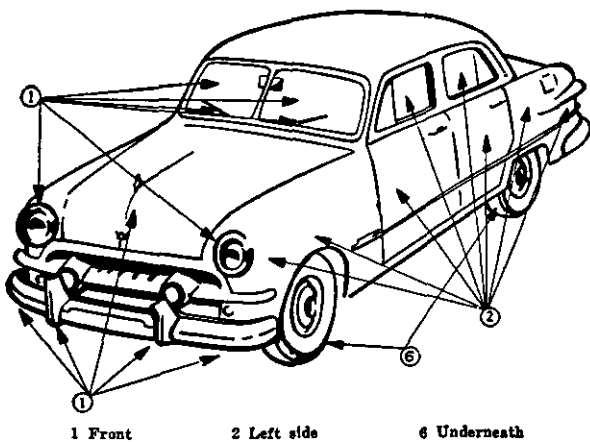


Figure 137. Motor vehicle examination points.

parts. Adhering foreign substances, such as fabric or blood?

- (6) *Windshield, left and right windows, hood, left and right fenders, and running boards.* Fabric or fiber impressions?
- (7) *Headlights, foglights, stoplights, spotlights, parking lights, turn or signaling lights.* Working properly? Bright or dim? Broken lenses? Recover and retain all broken particles of glass found. Keep separated as to sources.
- (8) *Light rims.* Bent? Recently replaced?
- (9) *Grease fittings, crankcase pan, axle and axle housing, differential, spring shackles and bolts, and steering assembly.* Fabric abrasion marks? Pieces of fabric or fiber? Blood?
- (10) *Color of paint.* Solid or two-tone? In taking standards for comparison, remove paint flakes to base metal including primer coat.

3. Examine the Interior

a. Record motor and body numbers, make, year, model, etc.

b. Take speedometer mileage totals. Was speedometer operating?

c. Note whether foot and emergency brakes were operating. Note condition.

d. Note whether gas gauge was operating. Check contents of gas tank.

e. Note whether horn was operating.

f. Check recent servicing stickers (lubrication, oil change, and inspection stickers, etc.). Note date and mileage recorded on the stickers.

g. Check evidence of ownership, registration, or insurance that may be attached to some interior part of vehicle or may be in an interior compartment.

h. Remove, tag, list, and secure all personal property. (If owner is present, all personal property not required as evidence should be returned to him. He should receipt for property that will be held by military police. If owner is not present, personal property should be inventoried in the presence of witnesses and promptly stored in a military police evidence room with a copy of the witnessed inventory attached thereto.)

APPENDIX XI

UNITS OF MEASURE AND CONVERSION

1. English System of Linear Measure

12 inches	-----	1 foot
36 inches	-----	1 yard
3 feet	-----	1 yard
1,760 yards	-----	1 mile statute
2,026.8 yards	-----	1 mile nautical
5,280 feet	-----	1 mile statute
6,080.4 feet	-----	1 mile nautical
63,360 inches	-----	1 mile statute
72,963 inches	-----	1 mile nautical

2. Metric System of Linear Measure

1 millimeter	-----	0.1 centimeter	-----	0.0393 inch
10 millimeters	-----	1.0 centimeter	-----	0.3937 inch
10 centimeters	-----	1.0 decimeter	-----	3.937 inches
10 decimeters	-----	1.0 meter	-----	39.37 inches
10 meters	-----	1.0 dekameter	-----	32.81 feet
10 dekameters	-----	1.0 hectometer	-----	328.1 feet
10 hectometers	-----	1.0 kilometer	-----	0.62 mile
10 kilometers	-----	1.0 myriameter	-----	6.21 miles

3. Kilometers to Miles

	<i>Rough</i>	<i>Exact</i>
1 kilometer	-----	0.6 miles (0.62 miles)
5 kilometers	-----	3 miles (3.10 miles)
10 kilometers	-----	6 miles (6.20 miles)
25 kilometers	-----	15 miles (15.50 miles)

4. Meters to Yards

	<i>Rough</i>	<i>Exact</i>
1 meter	-----	1 yard (1.09 yards)
5 meters	-----	5 yards (5.47 yards)
10 meters	-----	11 yards (10.94 yards)
25 meters	-----	27 yards (27.35 yards)
50 meters	-----	55 yards (54.70 yards)
75 meters	-----	82 yards (82.05 yards)

5. Meters to Feet

	<i>Rough</i>	<i>Exact</i>
1 meter	-----	3 feet (3.28 feet)
5 meters	-----	16 feet (16.40 feet)
10 meters	-----	33 feet (32.81 feet)
25 meters	-----	82 feet (82.00 feet)

6. Yards to Meters

	<i>Rough</i>	<i>Exact</i>
1 yard	-----	1 meter (0.91 meter)
5 yards	-----	5 meters (4.57 meters)
10 yards	-----	9 meters (9.14 meters)
25 yards	-----	23 meters (22.85 meters)

7. Kilometers per hour to Miles per hour

<i>KPH</i>	<i>MPH</i>	<i>Exact conversion</i>
5 KPH	-----	3 MPH (3.1 MPH)
10 KPH	-----	6 MPH (6.2 MPH)
15 KPH	-----	10 MPH (9.3 MPH)
20 KPH	-----	13 MPH (12.4 MPH)
25 KPH	-----	15 MPH (15.5 MPH)
30 KPH	-----	18 MPH (18.6 MPH)
35 KPH	-----	20 MPH (21.7 MPH)
40 KPH	-----	25 MPH (24.9 MPH)
50 KPH	-----	30 MPH (31.0 MPH)
60 KPH	-----	35 MPH (37.2 MPH)
70 KPH	-----	43 MPH (43.4 MPH)
80 KPH	-----	50 MPH (49.7 MPH)
90 KPH	-----	55 MPH (55.9 MPH)
100 KPH	-----	60 MPH (62.1 MPH)

8. Conversion Factors

a. United States, British, and Metric Units.

<i>Multiply</i>	<i>by</i>	<i>to obtain</i>
Acres	-----	43,560 Square feet
Acres	-----	4047 Square meters
Centimeters	-----	.03281 Feet
Centimeters	-----	.3937 Inches
Cubic centimeters	-----	.06102 Cubic inches
Cubic centimeters	-----	.001 Liters
Cubic feet	-----	1728 Cubic inches
Cubic feet	-----	.02832 Cubic meters
Cubic feet	-----	.03704 Cubic yards
Cubic inches	-----	16.39 Cubic centimeters
Cubic inches	-----	.0005787 Cubic feet
Cubic meters	-----	35.31 Cubic feet
Cubic meters	-----	1.308 Cubic yards
Cubic yards	-----	27 Cubic feet
Cubic yards	-----	.7646 Cubic meters
Feet per minute	-----	.01136 Miles per hour
Feet per second	-----	.5921 Knots
Feet per second	-----	.6818 Miles per hour

<i>Multiply</i>	<i>by</i>	<i>to obtain</i>
Inches -----	2.540	Centimeters
Inches -----	.08333	Feet
Kilometers -----	.6214	Miles
Kilometers -----	.5396	Miles (nautical)
Knots -----	1.152	Miles per hour
Knots -----	1	MPH (nautical)
Meters -----	100	Centimeters
Meters -----	3.281	Feet
Meters -----	39.37	Inches
Meters -----	1.094	Yard
Miles -----	5280	Feet
Miles -----	63,360	Inches
Miles -----	1.609	Kilometers
Miles -----	.8684	Miles (nautical)
Miles -----	1760	Yards
Miles (nautical) -----	6080	Feet
Miles (nautical) -----	1.1516	Miles
Miles per hour -----	88	Feet per minute
Miles per hour -----	.8684	Knots
Square centimeters ---	.1550	Square inches
Square feet -----	929	Square centimeters
Square feet -----	144	Square inches
Square inches -----	6.452	Square centimeters
Square inches -----	.006944	Square feet
Square meters -----	10.76	Square feet
Square meters -----	1.196	Square yards
Square miles -----	640	Acres
Square miles -----	2.590	Square kilometers
Square yards -----	.0002066	Acres
Square yards -----	9	Square feet
Square yards -----	1296	Square inches
Square yards -----	.8361	Square meters
Yards -----	3	Feet
Yards -----	36	Inches
Yards -----	.9144	Meters

Multiply by to obtain

b. Chinese

Chang -----	10.49	Feet
Chi -----	12.59	Inches
Chih -----	14.094	Inches
Chun -----	1.259	Inches
Feng -----	.1259	Inches
Hou -----	.0013	Inches
Li -----	.0126	Inches
Tsun -----	1.409	Inches

c. Japanese

Bu -----	.12	Inches
Cho -----	119	Yards
Jo -----	3.31	Yards
Ken -----	1.99	Yards
Ri -----	2.44	Miles
Rin -----	.012	Inches
Shaku -----	.994	Feet
Shaku -----	11.93	Inches
Sun -----	1.2	Inches
Tan -----	.245	Acres
Tsunbo -----	3.953	Square feet

d. Russian

Arshin -----	28	Inches
Dessiatina -----	2.7	Acres
Duim -----	1	Inches
Foute -----	1	Feet
Milya -----	4.64	Miles
Sazhen -----	7	Feet
Verst -----	.663	Miles

INDEX

	Paragraph	Page		Paragraph	Page
Accident, classified shipment -----	105c	91	Construction -----	98-99	79
Accident, nuclear -----	139b	109	Signs -----	99	80
Accident, traffic -----	77	59	Supervisor, MP -----	18c(3)	10
Causes -----	78	59	Convoy, escort -----	87-89, 140-146	73, 110
Chain of events -----	79	60	Counterguerrilla, TCP -----	129b(5)	104
Classification -----	80	61	Counterguerrilla, TCP -----	120d	100
Data -----	34d	29	Crossings, bridge and others -----	156-161	118
Investigation:			Fords -----	160	124
Duty officer -----	21	12	Types -----	159	120
Equipment -----	81	61	Caution -----	159b(1)	124
Preparation -----	81	61	Normal -----	159a	120
Recording -----	83	66	Risk -----	159b(2)	124
Reporting -----	82d, 82e, 83	62, 63, 66	Special -----	159b(2)	124
Steps -----	82	61	Curves, measurements -----	App. VI	159
Supervisor -----	18, 19	10, 11	Defiles -----	147-150	114
Stages of accident -----	79	60	Desert operations -----	175-176	131
Theater of operation -----	129a	103	Desk sergeant -----	20	11
Airborne operation -----	173, 174	131	Detour:		
Airborne operation signs -----	174	131	Signs -----	99	80
Amphibious operation -----	170-172	129	Supervisor -----	18c(3)	10
Area damage control -----	181-183	133	Traffic control -----	100	80
Armed forces traffic tickets -----	72, 76a	57, 58	Diagram, accident -----	83b	66
ACof S, G1, Role in traffic control -	10a	5	Disaster -----	18c(2)	10
ACofS, G2, Role in traffic control -	10b	6	Dismount point -----	162-164	125
ACofS, G3, Role in traffic control -	10c	6	Driving too slow -----	59	53
ACofS, G4, Role in traffic control -	10d	6	Drunken driving -----	64	54
ACofS, G5, Role in traffic control -	10e	6	Accident -----	84b	69
Baton -----	40b, App.III	34, 143	Duties of military police -----	12-14	7
Blackout -----	124	101	Duty officer -----	21	12
Briefing:			Education -----	5	4
Point control -----	38a	32	Enforcement -----	6	4
Reconnaissance -----	134	107	Action -----	71	57
Traffic control -----	109	95	Drunken driving -----	64	54
Bridges:			Driving too slow -----	59	53
Classification -----	App. VIII	170	Lane use -----	60	54
Crossing -----	156-161	118	Parking -----	62	54
Check Points -----	151-153	115	Pedestrian violations -----	63	54
Motor patrol -----	129b(6)	105	Speeding -----	58	50
TCP -----	120e	100	Turning movement -----	61	54
Civil defense -----	103	88	Enforcement policies -----	56	49
Classification:			Enforcement, preventive -----	6c	5
Bridge -----	158	118	Enforcement, selective -----	6d, 55	5, 48
Road network, NATO -----	App. IX	184	Engineer officer, staff role in		
Traffic accident -----	80	61	traffic control -----	10h	7
Traffic -----	2c	3	Engineer regulating point -----	166	127
Vehicle -----	158c	120	Engineer, signs -----	90	76
Road -----	App. VIII	170	Engineering -----	4	4
Route -----	App. VIII	170	Equipment -----	App. IV	159
Collision diagram -----	34d(1)(b)	29	Accident investigation -----	81	61
Commander, role in traffic control -	9	5	Defiles -----	150	115
Condition diagram -----	34d(1)(b)	29	Military policeman, traffic		
Condition map -----	35	30	control -----	38b	32

	Paragraph	Page	Paragraph	Page
Equipment— <i>Continued</i>				
Motor patrols	48, 128	42, 103	Mirror box	58c 51
Point control	38	32	Motor patrols:	
Signs	90	76	Checkpoint	129b(6) 105
Traffic control	108	94	PCS	46-52 42
Traffic control post	119	99	Counterguerrilla	129b(5) 104
Escorts:			Equipment	App. IV 159
CONUS	87-89	73	Functions and mission	46, 51, 52, 129 42, 44, 103
Methods	88, 143, 144	73, 111, 112	Road reconnaissance	52 44
Special weapon	145	113	Theater of operations	126-130 103
Supervisor	18c(4)	10	Mountain operations	179-180 132
Theater of operations	140-146	110	Movement	2c 3
Estimate of situation	113	97	Movement credit	App. IX 184
Fire, traffic control	102	88	Movement priorities	110, 111, App. IX 96, 184
Flashlight, signals	40b, App. III	34, 143	NATO road network	App. IX 184
Fleeing the scene	82a, 82d, 84a, App. X	62, 69, 188	NATO sign	App. II 138
Fords	160	124	Northern operations	179-180 132
Gradient	App. IV	161	Nuclear:	
Hand signals	40, App. III	34, 143	Accident	145b 113
Highway regulation	2b, 107, App. IX	3, 94, 184	Attack	181-183 133
Traffic headquarters	10d(2)	6	Traffic control	123 101
Holding area	121	100	Incident	145b 113
Defiles	149c	114	One-way routes, principles	25 13
Information:			One-way operations construction and detour	100f 80
Motor patrols	48f, 51, 129b	42, 44, 103	Operator's report of motor vehicle accident	82g 65
Nuclear accident	105	91	Overlay, reconnaissance	139, App. VIII 109, 170
Public	105	91	Parking	27 14
TCP	120b	99	Accident scene	82a 62
Inspection, vehicle	101	86	Dimensions	27 14
Intelligence:			Enforcement	62 54
Motor patrol	129b	103	Temporary	85-86 70
TCP	120c	99	Patrol supervisor	19 11
Intersection, traffic control	43	36	Pedestrian	63 54
Intersections, accident prone	26	14	Photography, accident investigation	82, App. V 61, 161
Jungle operations	177-178	131	Plans:	
Law	8	5	PCS	22-35 12
Map:			Theater of operations	106-116 94
Condition	35	30	Platoon	113-115 97
Holding area	121	100	Point control:	
Measle	App. VII	168	Baton	40, App. III 34, 143
Spot	34a	29	Coordination	43-44 36
Reconnaissance	App. VII	168	Daytime	40a 34
Traffic circulation	App. VII	168	Definition	36 32
Traffic control	App. VII	168	Detour	100 80
Traffic control team	App. VII	168	Emergency entrances	45b 41
Unit location	App. VII	168	Flashlight	40, App. III 34, 143
Measurements, accident investigation	82e(3)(b)	64	Ground orientation	39 34
Military police:			Hand signals	40 34
Duties	13	7	Nighttime	40b 34
Platoon	113, 114, 115	97	Preparation	38 32
Squad	116	97	Rules	37 32
Military police reports	52, 76, 129	44, 58, 103	Safety equipment	38 32
			Schools	45a 41
			Traffic signal	41 35
			Whistle, use of	42 36
			Protection of property	75, 82b 58, 62
			Provost Marshal	10f 6

	Paragraph	Page		Paragraph	Page
Radar	58b	51	Signals, flashlight	40b, App. III	34, 143
Rear area:			Signals, hand (see hand signals)	40	34
Area damage control	181-183	133	Signal officer, staff role in		
CBR	115	97	traffic control	10g	6
Reconnaissance	131-139, App. VIII	106, 170	Signals, traffic	97	78
Road and safety	52	44	Manual operation	41	35
Recording, accident			Obedience, field studies	32	24
investigation	83	66	Sketches, accident investigation	82e, 83	63, 66
Reduced lighting	125	102	Skidmarks	82e, 83c	63, 66
Refugee control, motor			Special events	29	18
patrol	129b(8)	105	Speed, field studies	95b, 95c	76
Refugee control, TCP	120g	100	Speed zones	28	15
Regulation (See Highway			Speeding	58	58
Regulation)			Spot map	34a	29
Reports, traffic violation	76-129	58	Squad	116	97
Rerouting	122	100	Staff role in traffic control	10	5
River crossings	165-169	127	Straggler control, motor patrol	129b(7)	105
Roadblocks	154-155	117	Straggler control, TCP	120f	100
Road classification	141	110	Supervisor	15-20	9
Road network, NATO	App. IX	184	Support Command role in traffic		
Route classification	App. VIII, IX	170, 184	control	11	7
Route designations	2, App. IX	3, 184	Symbols, reconnaissance	App. VIII	173
Dispatch	2g	4	Traffic circulation map	App. VII	168
Open	2e	3	Traffic control definition	2d	3
Regulated	2g	4	Traffic control, post (TCP)	117-125	98
Reserved	2h	4	Traffic control team, map	App. VII	168
Supervised	2f	3	Traffic definition	2a	3
Scuff marks	83d	68	Traffic load	23	13
Selective enforcement	6d, 55	5, 48	Traffic studies	30-35	24
Signs:			Traffic volume	31	24
Airborne operation	174	131	Tolerances	56	49
Civil defense	103	88	Triangulation	83a	66
Classification	92	76	Unit location, map	App. VII	188
Construction	98-99	79	Vehicle inspection	101	36
Detours	98-99	79	VIP, escorts	80b	61
Effective use	93	76	Violations	57-65	50
Erection	95	76	Reports	72, 76, 82, 129	57, 58, 61, 103
Inventory	52c	44	Witnesses	74	57
NATO	App. II	138	Violators	66-76	55
Northern operations	180	132	Warning	72	57
Obedience	32	24	Whistle, use	42	36
Reconnaissance	52c	44	Witnesses, accidents	82	61
Roadblock	104	88	Witnesses, traffic violation	74	57
Standard	90-97	76			
TCP	119, App. IV	99, 159			
Signals, baton	40b, App. III	34, 143			

By Order of the Secretary of the Army:

HAROLD K. JOHNSON,
General, United States Army,
Chief of Staff.

Official:

J. C. LAMBERT,
Major General, United States Army,
The Adjutant General.

Distribution:

Active Army:

DCSPER (2)
ACSI (2)
DCSLOG (2)
ACSFOR (2)
TPMG (50)
CORC (2)
TAG (2)
TIG (1)
TJAG (2)
CAR (2)
CNGB (2)
USACDCMPA (5)
USACDCJAA (1)
USCONARC (5)
USACDC (2)
ARADCOM (2)
ARADCOM Rgn (1)
OS Maj Comd (5)
MDW (1)
Armies (5)
Div (2)
Bde (1)
Regt/Gp (1)
MP Bn (2) except
TOE 19-35 (5)

19-55 (5)
MP Co (2) except
TOE 19-27 (13)
19-29 (5)
19-37 (13)
19-57 (13)
19-67 (5)
19-217 (5)
MP Det/Teams (1) except
TOE 19-36 (3)
19-56 (3)
USACGSC (50)
USMA (1)
Br Svc Sch (1) except
USAES (25)
USAIS (56)
USAINTS (5)
TJAGSA (3)
USAOC&S (3)
USASCS (10)
USASWS (10)
USATSCH (2)
PMS Sr Div MP Units (1)
Instl (2)
USA Corps (3)

NG: State AG (3); units—same as Active Army except allowance is one copy for each unit.

USAR: Units—same as Active Army except allowance is one copy for each unit.

For explanation of abbreviations used, see AR 320-50.

☆ U.S. Government Printing Office: 1964-744-282/10108

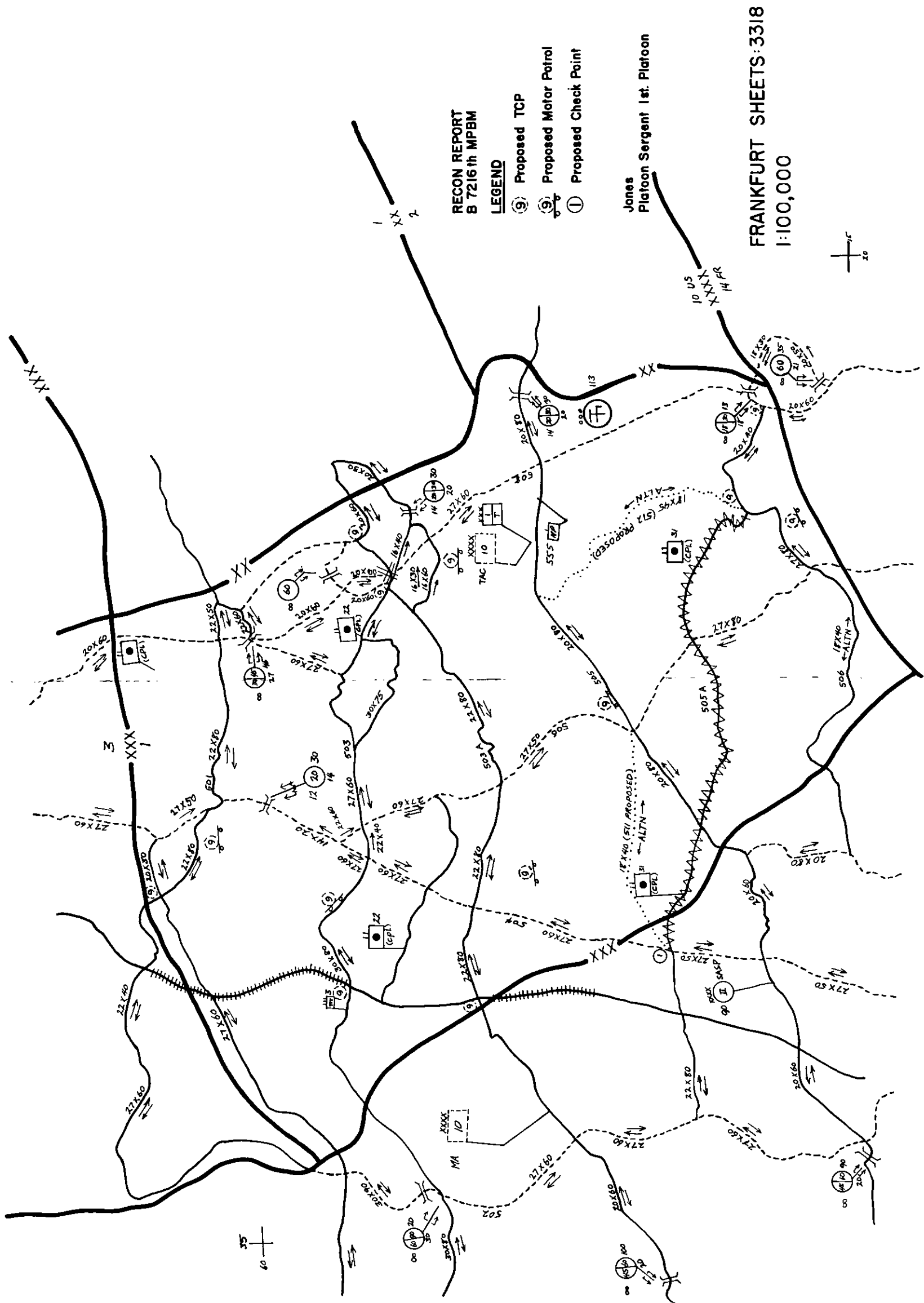


Figure 54. Example of route and traffic control reconnaissance overlay.