

Introduction

This file gives basic information on integrating the Duvoice VM with Mitel SX50 telephone system through the PBX Link DMI4 unit. Refer to the Mitel programming for more information. On an SX-50 the PBXLink *DMI4* emulates four DNIC 420 sets.

Switch Hardware Required

- Mitel SX50 telephone system with MS55 software.
- One DNIC 420 extension on a card per PBX Link port is required in slot one in the Mitel cabinet.
- One analog extension for the modem is recommended. If no extensions are available wire a trunk line to the modem using a TKM switch.

!!STOP AND READ!!

Below is the detailed instruction that must be followed step by step in order to integrate the SX50, DuVoice & DMI4 unit. There are three different areas of programming required and all must be followed.

Step 1 Program your SX-50

Step 2 Configure the DMI 4 for SX-50 (unless preconfigured for sx-50)

Step 3 Connectivity of DMI to DuVoice and SX50

Programming your SX-50 Step 1 (a-e)

Set up the Voicemail ports

1a) Create a Class of Service for the Voicemail ports

The four digital extensions need to be assigned a class of service, **COS 2** in this **example**, that will be used for the voicemail ports. This needs to be changed to allow **Auxiliary Attendant** functionality. This is done by using commands 121 through 129, depending on which class of service has been selected for the voicemail ports. Register **7**, position **C**, is set to **1**. In our example it would be command **122 for COS 2**. To accomplish this: At the attendant console, dial **#122**, and press the **enter** soft key. Scroll through the registers using the **next** softkey until register **7** is reached. Scroll through the register using the **_** key and change the **3rd** digit (c) to **1**. The register should now read 071102. Press **EXIT** key if complete

1b) Build the four extensions

This is done using commands 301 to 310, where the two digits after the 3 are the slot number of the PBX's linecard. In our example, the voicemail ports will be on line card 5, ports 1 through 4. In this case we dial **#305 enter**. Register 1 will appear. This is the register for port 1. In our example, R1= 010200**201**. Pressing **next** gives register 2, which is port 2. R2=020200**202**. Repeat this procedure for all four ports, i.e., registers R3 and R4.

1c) Add a Message Waiting key to the port(s) used to control MWI

Note: Message Waiting Indicators are sent through the serial link to the DNIC Box from the DuVoice system. It is also important to have the **MWI On** and **MWI Off** field left **blank** in the configuration of the **DMI4**. This is accomplished by using commands 401 to 480, depending on the slot occupied by the DNIC card and the circuit number on that card. The command number can then be read from the following table.

Chapter 3 – Programming Mitel PBXs

Slot 1 Slot 2 Slot 3 Slot 4 Slot 5 Slot 6 Slot 7 Slot 8 Slot 9 Slot 10

Port 1 401 409 417 425 433 441 449 457 465 473

Port 2 402 410 418 426 434 442 450 458 466 474

Port 3 403 411 419 427 435 443 451 459 467 475

Port 4 404 412 420 428 436 444 452 460 468 476

Port 5 405 413 421 429 437 445 453 461 469 477

Port 6 406 414 422 430 438 446 454 462 470 478

Port 7 407 415 423 431 439 447 455 463 471 479

Port 8 408 416 424 432 440 448 456 464 472 480

In our example, the voicemail ports are on line card 5.

By default, the Message Waiting Indicators are set and cleared on port four. (If more than one **DMI4** is installed, then the lamps are set and cleared by the last port of the last **DMI4** in the chain). The 420 sets used for setting and clearing message waiting lamps (Programmed on line four, extension 204 in our example) must have an Auxiliary Attendant key (type 8) programmed on **key 12** of the set, with the Message Waiting Function (value 10) assigned to it. This is explained below. To program the message waiting line: Dial **#436** and press the **enter** soft key. Press the **next** key until register 12 is reached. This controls key 12. Key 12 should be programmed as follows: **R12=12810**.

1d) Build a Hunt Group

The SX-50 can have up to six hunt groups, configured using commands 361 through 366 respectively. Select a hunt group, say hunt group 3, then program it with the extensions of the four voicemail ports. In this case, to program the hunt group:

Dial **#363** and push the **enter** softkey. Set the first register to **R1=110**

Then press the **next** key and add the extensions **R2=2201**, **R3=3202**, **R4=4203** and **R5=5204** The remaining ports should be set to zero e.g. **R6=60**, **R7=70**, etc.

1e) Configure Users' Phones

If subscribers have names programmed, these must include the extension number at beginning of the name. For example, a user with the name **FRED** on extension **201** would become **201 FRED**. Users' extensions do not require any special programming beyond that required for any other extension. If Forward-On-Busy or Forward-On-No-Answer to voicemail is desired, then the appropriate COS options to enable forwarding must be enabled Call forwarding on the SX-50 is initiated from each user's phone, by using the Superkey on Supersets or an access code on other phone types.

Configuring the DMI 4 unit Step 2

You need to configure the PBXLink *DMI4* to tell it how your PBX and voicemail system are configured. There are many settings that can be changed. These are all described in this chapter. However, most of these can be left at the default setting on most systems, and only a few important ones need changing. These are described below.

Configuration Menus

The PBXLink *DMI4* is configured through menus available through the SMDI serial port (COM port). To access the configuration menus use HyperTerminal on the DuVoice system, you will need to stop the DuVoice services and use the same com port to administer the device that the DuVoice system is using to communicate through the SMDI port. The SMDI port is in SMDI mode by default. In this mode, it produces SMDI packets destined for the application program. (See fig 2)

To get it out of SMDI mode and into the menus type M <enter> on the terminal. You will then see the main menu.

It looks similar to:

```
PBXLink 4x4 version 2.06.01 for Mite1 420
Copyright (c) Connected Systems Ltd. 1997-1998
1. Prime Number [491] (set to hunt group number)
2. MWI On []
3. MWI Off []
4. Advanced...
5. Diagnostics...
Q. Quit
```

Enter option:

If nothing appears, check the serial port settings on the terminal program. The SMDI port is always configured as 9600 bps, 8N1

Note: Depending on which PBX type the *DMI4* is configured for, the menus may look slightly different. Parameters ending in square brackets [] are values to be entered by the installer. Parameters ending in dots ... contain sub-menus with more parameters or prompts. When you select a sub-menu by entering the menu number followed by <enter>, that sub-menu will be displayed. For example, type: 4<enter> Chapter 7 – Configuring the *DMI4* 31

This menu appears:

```
Advanced
1. PBX...
2. SMDI...
3. Activation Code...
4. Reset To Factory Defaults...
Q. Quit
```

Enter option:

```
Entering
Q<enter>
```

or pressing the ESC key brings you up to the next higher level menu. If you keep going, you exit from the menus and the card returns to SMDI mode.

It displays:

```
Press M <ENTER> to return to menu
```

At this point, the *DMI4* is functioning and it is safe to exit the terminal software and start the voicemail system.

Parameter Table

The parameters are arranged in a tree structure as follows:

1. **PBX Type** [Mitel SX-50]
2. **Prime Number** [491] (set to hunt group number)
3. **MWI On** []
4. **MWI Off** []
5. **Advanced...**
 1. **PBX...**
 1. **Extension Length** [0] (number of digits in your number plan)
 2. **aLaw** [OFF] (leave off unless outside of USA or Canada)
 3. **MWI End** []
 - Q. Quit
 2. **SMDI...**
 1. **Message Desk** [1] (leave default set to 1)
 2. **CPID Mask** [0000000]
 3. **MWI Ports** [] (controls what DMI Port will activate MWI's)
 4. **Disconnect** [OFF]
 5. **Include Names** [OFF] (leave as default set to OFF)
 - Q. Quit
 3. **Inband Tones...**
 1. **Suppress Tones** [ON] (if OFF DTMF in-band will be passed to DuVoice VM)
 2. **Delay (ms)** [300] (Leave as default 300)
 - Q. Quit
 4. Not needed for this configuration

Parameters Explained

MWI On [<dial code>]

This parameter informs the **DMIA** of the code to dial in order to set a message-waiting indicator on a user's phone. After dialing the code, the **DMIA** dials the extension number. A comma in the string causes the **DMIA** to pause for 1/2 second. You may find this useful if you need the MWI ON code to be a twopart number, perhaps an access code to route to a connected switch, a pause while the call is connected to that switch, and then the MWI code for that switch. See **MWI End** below for another sometimes helpful option concerning MWIs. Note: This (and the MWI-Off) are not required on Norstar or if Inband Integration is being used. Also they should be left blank for SX-50 if the MWIs will be serviced using the Auxiliary Attendant key as described in the section for the SX-50.

MWI Off [<dial code>]

This parameter informs the **DMIA** of the code to dial in order to clear a message-waiting indicator on a user's phone set. After dialing the code, **DMIA** dials the extension number. **Advanced...** These parameters can normally be left unchanged.

MWI End []

This option provides for a string of up to fifteen digits to be sent to the PBX at the end of the normal MWI string. Another useful character that may be included within this string is a comma. Each comma causes a 1/2 second pause in the sending of the string. For example, if the PBX requires a pause after the extension is sent but before the line is put back on-hook, you can use a comma in this **MWI End** string.

SMDI...

CPID Mask [0000000]

When the **DMIA** sends an extension number in an SMDI packet, it uses the CPID Mask to pad that extension number to the required number of digits. For example, if

the extension number is 1234 and the CPID Mask is 0000000, the **DMIA** outputs the leftmost three 0s from the CPID Mask and then the four digits of the extension. Most voicemail systems will work with the default value of 0000000 (7 zeros). However, if the voicemail system expects ten digits in the SMDI packet, then a value of 0000000000 (10 zeros) should be used. If the voicemail system expects other digits in front of the extension numbers, then the CPID mask can be used to achieve this too. For example, 8880000000 would result in all SMDI packets being ten-digits long and the three left-most digits would always be 888.

MWI Ports []

This parameter controls which port the **DMIA** uses to pass the SMDI's MWI command to the PBX. In addition, on the Norstar it determines which port the **DMIA uses**, in addition to port 1, to build the name table. It is recommended that this parameter be left blank unless there is a valid reason why it should be changed to something other than its default setting. **If changed, this string must be exactly ten digits long.** Each digit position, 0 . . . 9, corresponds to the *last* digit of an extension number whose MWI needs to be set or cleared. The value in that digit position is a port number (1 through 4) which is the port number to be used for setting and clearing MWIs on extensions ending with that digit. If this field is left blank, then port number 4 is used for all SMDI-controlled MWI setting and clearing operations. (Note that additional PBX configuration may be required to enable a port to be able to set and clear MWIs.)

For example, if **MWI Ports** is set to 3333333333, then all MWI setting and clearing is performed by port 3 instead of port 4. If **MWI ports** is set to 3434343434, then even numbered extensions have their MWIs set and cleared by port 3 and odd-numbered extensions have their MWIs set and cleared by port 4, thus splitting the work of setting and clearing MWIs between ports 3 and 4 (this would only be required on systems with a large number of voicemail ports). We recommend that this parameter is set so that the last port does the MWI processing: the last port is least likely to be used for incoming calls and thus has the most free time available to process MWIs.

If your system has multiple **DMIA**s (using SMDI) installed (see Chapter 8), only the last **DMIA** in the system processes MWIs. The **MWI Ports** parameter then controls which port(s) on the *last DMIA* is used for this, and is ignored by the other **DMIA**s.

Disconnect [OFF]

Setting this parameter to ON enables the **DMIA** to produce a non-standard SMDI packet when a caller hangs-up. This is in addition to the normal disconnect supervision which is a drop in the loop current on the analog line. The non-standard SMDI packet would have a format similar to:

MD0010001H 0000000

Inband Tones . . .

Suppress Tones [OFF]

This parameter allows inband tones to be suppressed on the **DMIA**. This is needed if the **DMIA** is going to be used for SMDI integration or for providing analog lines without any integration.

Delay (ms) [300]

This is how long after the analog line goes off hook to the **DMIA** that the **DMIA** waits before it plays the inband tones to the voicemail system.

Step 3 Connectivity of DMI to DuVoice and SX50

Description of DMI figures

Figure 1- DMI to SX-50 DNIC ports

DMI unit showing the 4 stand alone RJ connections to the Mitel SX-50 DNIC ports that are configured for a 420 set.

Figure 2- DMI to DV2000 or DV4

In this figure you see the 2pair USOC connection from the DMI to DuVoice analog ports and the DB9 serial cable that connects to the DV2000 or DV4 serial port.

Figure 3- Overview of connectivity.

This figure gives the overall mapping of all involved hardware.

Figure 1

Identifying the Parts

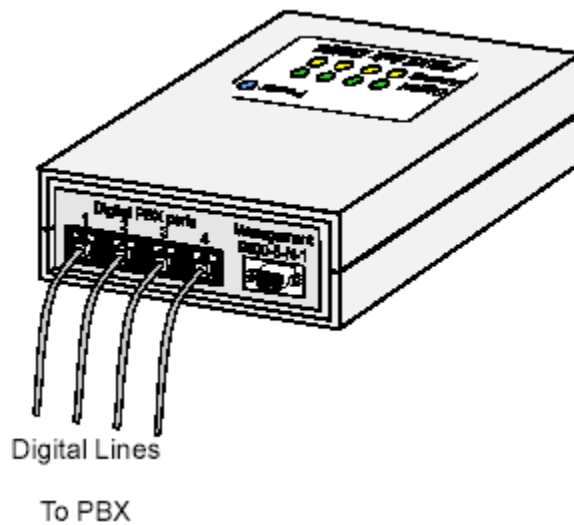

Figure 2.

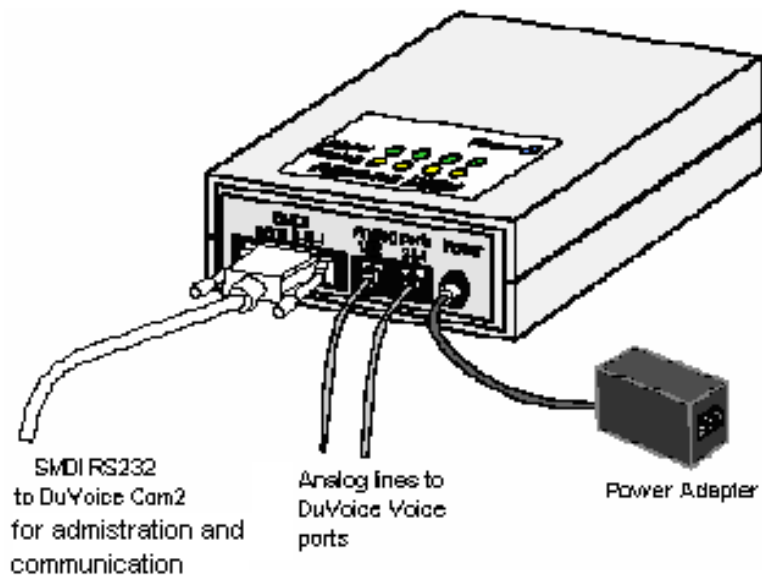

Figure 3.

