

ML-322

MAXLOGIC CONVENTIONAL FIRE EXTINGUISHING CONTROL PANEL

ML-322 series operates on cross-zone principle, has 4 detection zones and one extinguishing release output which is programmable according to site needs. Conventional extinguishing panel is microprocessor controlled, offers high performance and can easily be integrated into all extinguishing projects.



PRODUCT FEATURES

- Compatible with EN 12094 -1, EN-54-2 and EN-54-4
- 4 zones, 1 extinguishing release output
- Detection of two devices alarming in the detection zone, indicating the zone with fire led.
- Extinguishing-related front panel LEDs and LCD screen provide full information on extinguishing control status
- Up to 8 extinguishing status indicator units can be connected to one fire extinguishing panel.
- Programmable 1st stage sounder output delay
- Delay can be assigned for detection zones
- Adjustable delay and extinguishing times
- Non-latching zone option
- Real time clock
- Supervised inputs and outputs
- Extinguishing release countdown timer
- Fire and fault leds for each detection zone
- Open / short circuit control of all input (supervised detecting zone inputs, extinguishing holding input, extinguishing canceling input, extinguishing start input, low-pressure input, extinguishing status switch input) lines
- Open / short circuit control of all output (supervised extinguishing output, second-level sounder output, fire sounder output, gas active output) lines
- Extinguishing mode can be changed remotely via extinguishing status key
- The panel can be set to automatic/manual extinguishing modes

- Fire and Fault relays active in case of fire and fault
- Extinguishing Status Switch relay, which is active when the extinguishing status switch is set to "Manual only"
- Hold relay that is active when the countdown is held while the extinguishing process is active
- Dry contact relay output for fire and fault
- Energy or volt free change over contact option for outputs
- Convenient structure for integration with mechanical systems
- Possibility to work with 8 input and 8 output with extension card. 8 ways I/O modules
- Ability to choose Cross-Zone working with computer software as active / passive
- Storing event logs up to 1000 events
- Event logs can be viewed with computer software
- Printing of event logs stored in memory via computer, printer via RS-232 port
- The desired zones can be assigned as extinguishing zones
- Detection zones can be disabled, tested,
- Zones can be set to disable and test modes. 1st and 2nd stage relay outputs, gas extraction output and extinguishing release button can be disabled
- Programmable delay and extinguishing time
- Panel indicators and controls can be moved, via optional extinguishing status indicators
- Updating software to main card of panel and inputs / outputs of expansion card to assigning different functions

TECHNICAL SPECIFICATIONS

Power supply	230V AC 50Hz
Battery	2 x 12V DC 7Ah
Zone number	4, Supervised
Zone output voltage	24V DC
Zone end of line resistance	6K8
Cable for zones	Between 0- 500 m. 1x2x0,8+0,8JH(st)H 500 - 1500 m. 1x2x1,5+1,5JH(st)H
Hold input	Supervised / Triggered with 470R
Flow switch input	Supervised / Triggered with 470R
Manuel release input	Supervised / Triggered with 470R
Low pressure input	Supervised / Triggered with 470R
Mode signal input	Supervised / Triggered with 470R
Cable for inputs	Cable should have 250mA capacity.
Extinguishing output	Supervised / 24V DC 1A Max. Current = during 2 sec. 2A
Cable for extinguishing output	Cable should have 2 A capacity
2. Level Sounder (Extinguishing sounder)	Supervised / 24V DC 250mA
Sounder1	Supervised / 24V DC 250mA
Sounder 2	Supervised / 24V DC 250mA
Cable for Sounder outputs	Cable should have 250mA capacity. After the connection, end of line voltage should be more than used device operating voltage limit

Gas released output	Supervised / 24V DC 250mA
Cable for gas released output	Cable should have 250mA capacity
Fire relay	30V DC 1A Dry contact
Fault relay	30V DC 1A Dry contact
Cable for relay output	Cable should have 1A capacity
Mode relay output	30V DC 100mA dry contact
Hold relay output	30V DC 100mA dry contact
Cable for signal relay output	Cable should have , 100mA capacity
24V auxiliary output	24V DC 250 mA automatic fuse protected
24V auxiliary output cable	Cable should have 250mA capacity. After the connection, end of line voltage should be more than used device operating voltage limit
Dimensions	300 x 400 x 100 mm
Weight (battery is excluded)	~ 3,9 kg (*)
Construction	1 mm DKP sheet
Surface	Epoxy paint
Mounting type	Surface, flush
Standard color	Gray (RAL 7015), White front of panel
Operating temperature range	(-5°C) - (+40°C)
Operating humidity range	%0-93 (non-condensing)

AN OVERVIEW OF THE WORK STRUCTURE OF THE SYSTEM

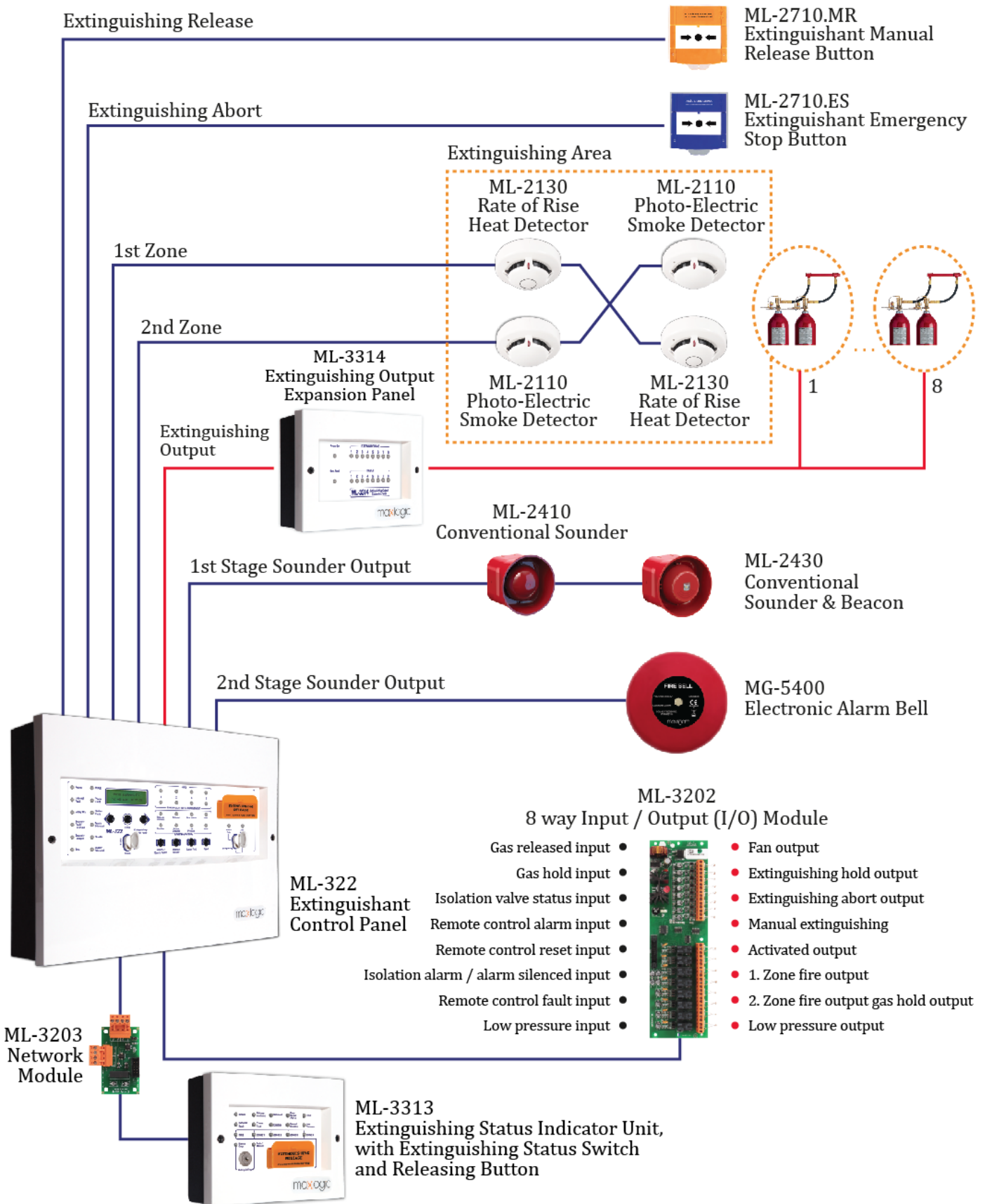

OPTIONAL PRODUCTS



ML-2710.ES Extinguishant Emergency Stop Button

ML-2710.MR Extinguishant Manual Release Button

Easy to use, innovative test key designed according to EN 12094-3, advanced technology resetting function and the features of the extinguishing emergency stop button having practical accessories are below.

- EN 12094-3 standardına uygun
- Compatible with EN 12094-3
- Compatible with surface and flush mounting
- Compatible with all conventional extinguishing panels
- User friendly
- IP22D protection class
- Protection cover
- Easily resettable
- High and stable operating performance



ML-3313 Extinguishant Status Indicator

Indicators and controls on the panel can be moved to a location further away from the location where the panel is located by using ML-3313 extinguishant status indicator unit.

- Control of the communication continuity
- LED notification of communication and fault conditions
- LED and internal buzzer operational test
- Model options of extinguishant condition with key and keyless which provides selecting extinguishant automatic or manual or only manual.
- Up to 8 pcs extinguishant condition indicator units can be connected to one pcs fire extinguishant panel.
- 4 supervised inputs for standby, cancel, extinguishant condition key and remote reset input.



ML-3314 Maxlogic Extinguishing Output Expansion Panel

ML-3314 Extinguishing Output Expansion Panel, it is used to increase the number of extinguishing outputs by connecting to the extinguishing output of ML-322 series fire extinguishing panels.

- 8 supervised extinguishing output
- To obtain the desired number of extinguishing outputs by connecting the panels in series with each other,
- According to the delay and extinguishing times determined by the software, the outputs should be active in order
- Display of activation and fault conditions with LEDs
- Easy cable entry to the panel from the top and back surface
- Surface mounting technology
- Aesthetic design
- High and stable operating performance



ML-2410 Conventional Sounder

ML-2410 Maxlogic conventional sounder is an advanced product with aesthetic design and superior operational performance that is used for audible notifications of fire alarms from panels and provides common use of all systems, from intelligent addressable fire alarm systems to conventional fire alarm systems. It is powered from conventional sounder line.

- Compatible with EN 54-3
- Special design for indoor use
- Adjustable flash frequency and coverage area
- Adjustable different 32 voice tone options
- Low or high volume power control
- Up to 100 dB(A) voice output
- Microprocessor controlled
- Produced by use of surface mount technology
- User friendly
- Stable sensitivity



ML-2430 Conventional Sounder & Beacon

ML-2430 Maxlogic conventional sounder and beacon is an advanced product with aesthetic design and superior operational performance that is used for visual and audible notifications of fire alarms from panels and provides common use of all systems, from intelligent addressable fire alarm systems to conventional fire alarm systems. It is powered from conventional sounder line.

- Compatible with EN 54-23 and EN 54-3:2014
- Special design for indoor use
- Adjustable flash frequency and coverage area
- Flasher light is scattered as cubic shape
- White, strong LED flasher
- Adjustable different 32 voice tone options
- Low or high volume power control
- Up to 100 dB(A) voice output
- Microprocessor controlled
- Produced by use of surface mount technology
- User friendly
- Stable sensitivity



MG-5400 Fire Alarm Bell

MG-5400 Fire alarm bell is a product that can be used by all systems from intelligent addressable fire alarm systems with Mavigard and Maxlogic brands to conventional fire alarm systems. It gives an audible output when generating a warning signal in fire alarm panels.

- Compatible with EN 54-3
- Special design for indoor use



ML-2110 Conventional Optical Smoke Detector
ML-2120 Conventional Fixed Heat Detector
ML-2130 Conventional Combine Heat Detector
ML-2140 Conventional Multisensor Detector

All detectors have superior sensitivity and stability thanks to microprocessor control. Smoke detectors utilize the scattered light-sensing principle. If smoke has been the inside of the optical chamber, smoke particles inside the chamber collide with transmitter beams and they fall on to the receiver. False alarms are prevented by advanced algorithms before the generated fire signal. Heat detectors have a heat detection sensor and if the ambient temperature reaches 60 ° C or a temperature increase of 30 ° C within 1 minute, a fire signal is produced by detecting a fire. In both detection methods, false alarms are prevented with the help of an advanced algorithm before generating a fire signal. Detectors are suitable for indoor use. Detectors are suitable for indoor use.

- Compatible with EN 54-7 and EN-54-5
- Microcontroller based design
- Remote indicator output
- Advanced software that provides high stability and sensitivity
- Advanced software prevents from false alarms
- Pollution control, compensation and alert
- Low optical measurement result warning (smoke detectors)
- Low power consumption
- Protection from electromagnetic interference
- Twin red fire alarm indicators for 360° viewing
- Compatible with all standard conventional fire alarm systems
- User friendly and easy mounting
- Durable construction against mechanical impact



ML-3202 I/O module for Maxlogic Conventional Fire Extinguishing Panel

It is an optional module with 8 programmable inputs and 8 programmable outputs capacity, which can be installed later on the panel.

Inputs	Outputs
• Manual Release Input	• Fan Output
• Gas Blocked Input	• Extinguishing Delayed Output
• Isolation valve status Input	• Extinguishing Cancel Output
• Remote Alarm Input	• Manual Extinguishing Activated Output
• Remote Reset Input	• Zone 1 Fire Output
• Silence Remote Alarm / Alarm Input	• Zone 2 Fire Output
• Remote Fault Input	• Gas Blocked Output
• Low Pressure Input	• Low pressure Output

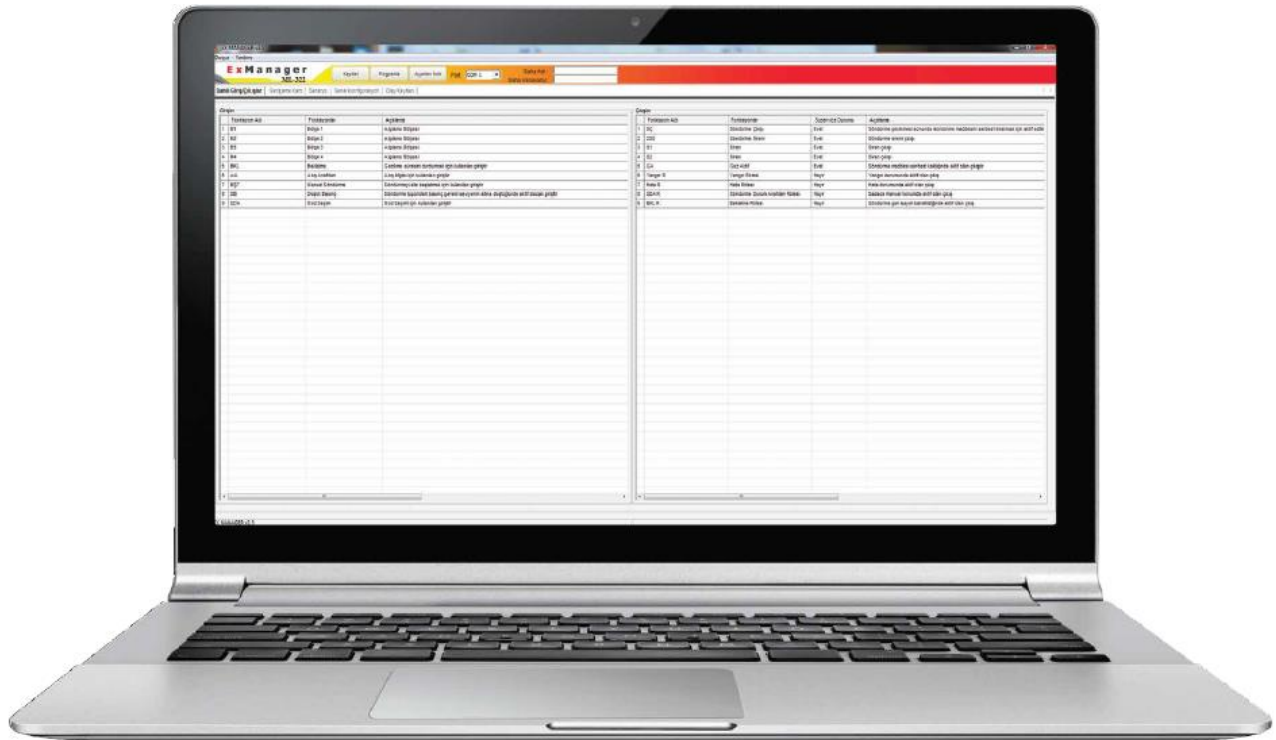

It is used to perform configuration operations in ML-322 panels.

- Ability to assign input/output functions to expansion card input outputs with internal inputs/outputs
- Include all internal inputs and outputs in scenarios
- Ability to include all expansion card inputs and outputs in scenarios
- With the general configuration feature, the desired zones can be selected as the extinguishing zone and the extinguishing status can be selected as yes or no in two alerts.
- Ability to download and print all event logs

EXTINGUISHING STATUS INDICATOR UNIT CONNECTION

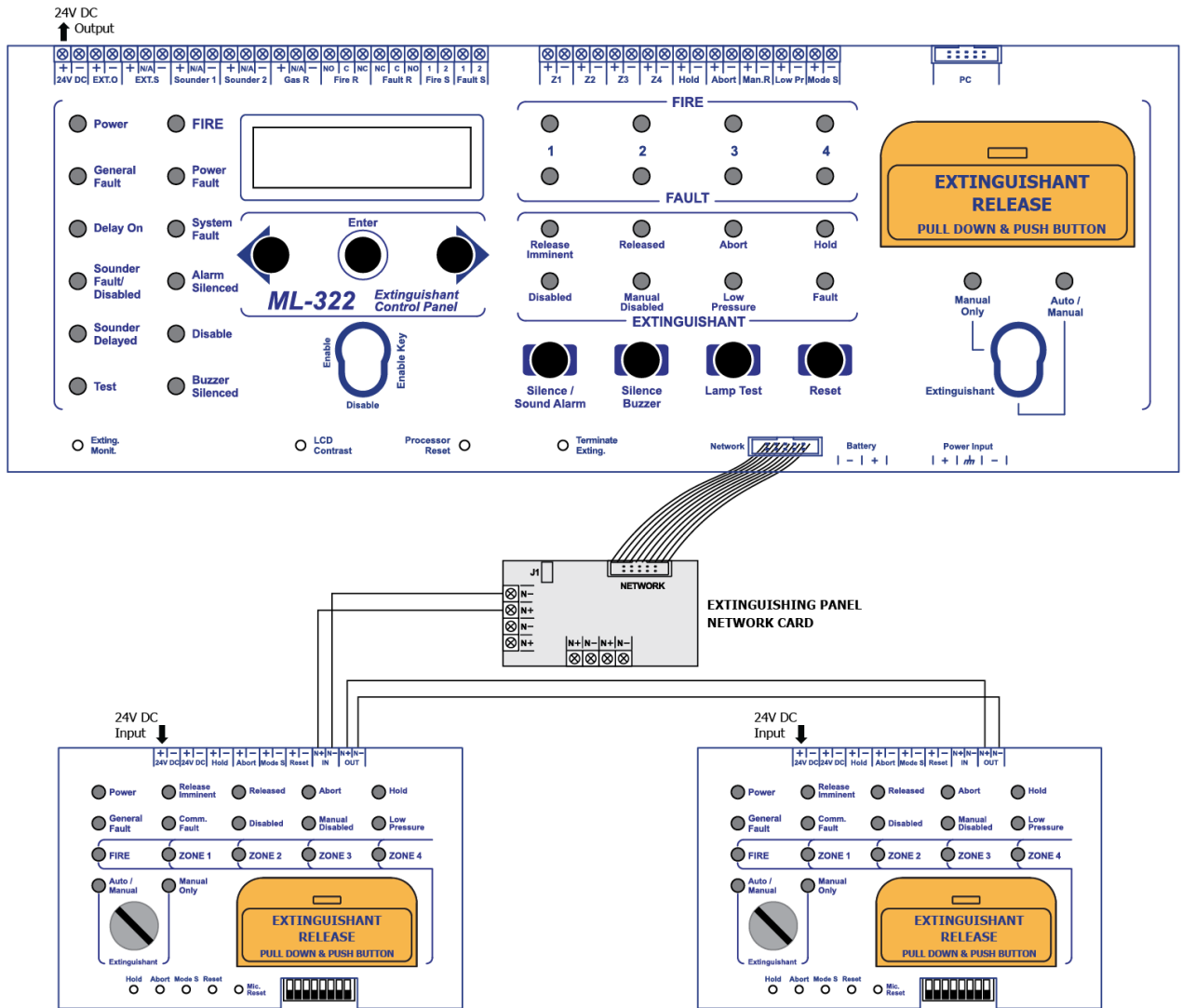

CONNECTION DIAGRAM

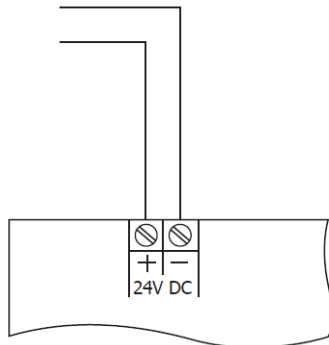

Reserve 24V DC output

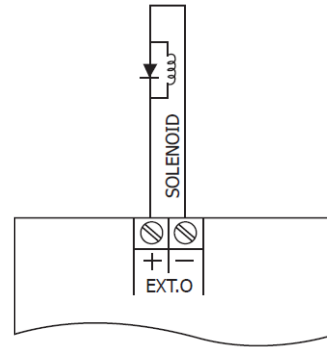

Solenoid connection to extinguishing output

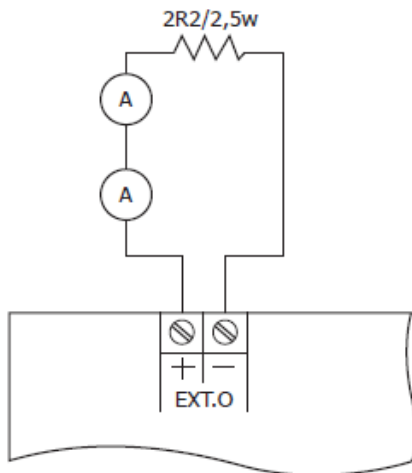

Activator connection to extinguishing output-1

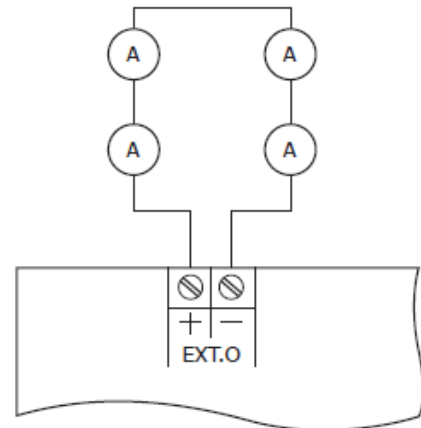

Activator connection to extinguishing output-2

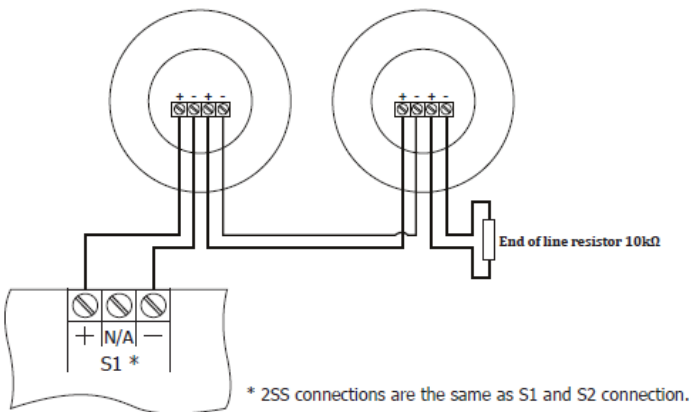

Sounder Outputs

* 2SS connections are the same as S1 and S2 connection.

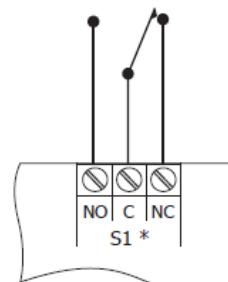

Programming sounder outputs for a different output.

* 2SS connections are the same as S1 and S2 connection.

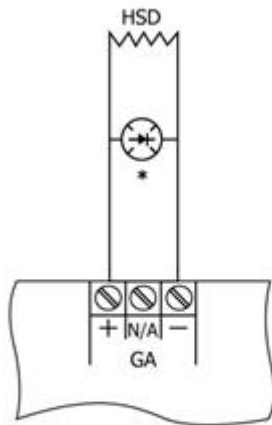

Gas activated output

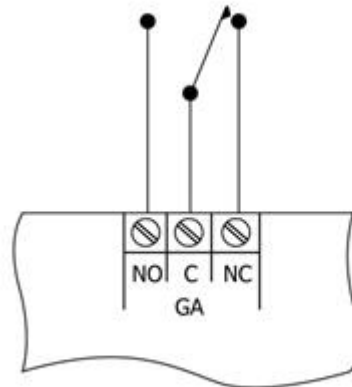

Programming gas active output for a different output

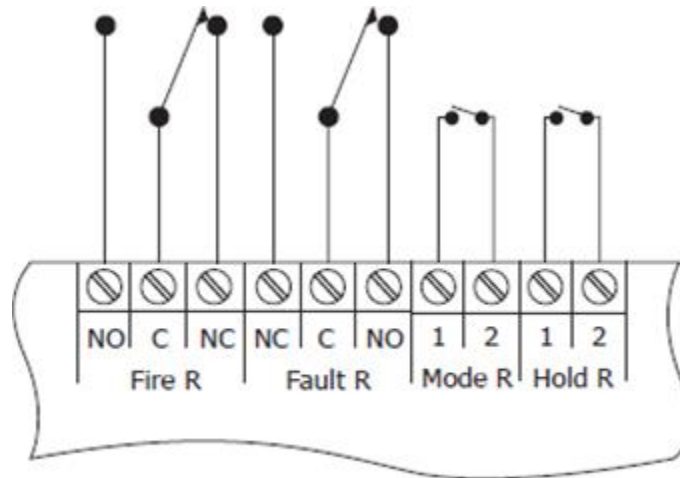

Relays on panel

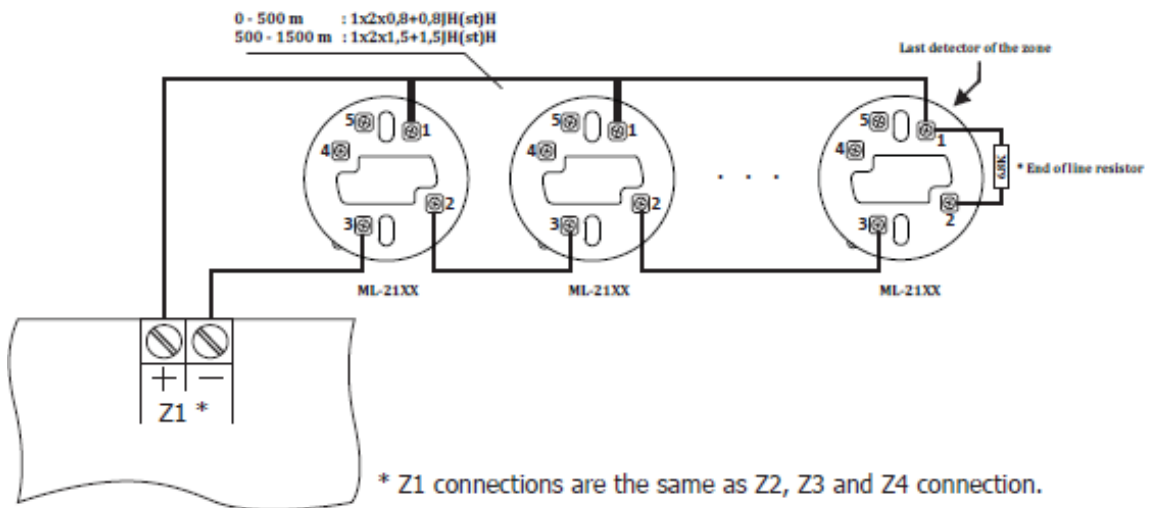
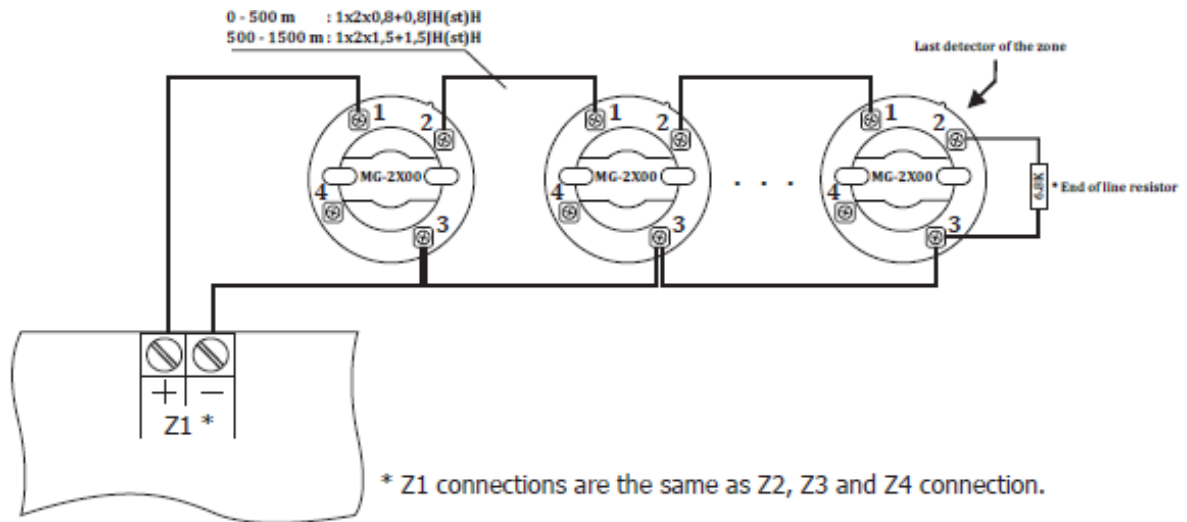

Detection zone lines

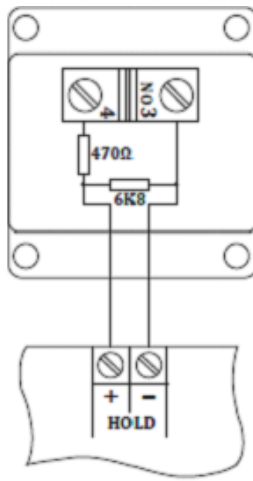

Abort Input

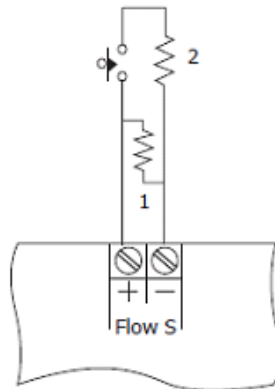

Flow Switch Input

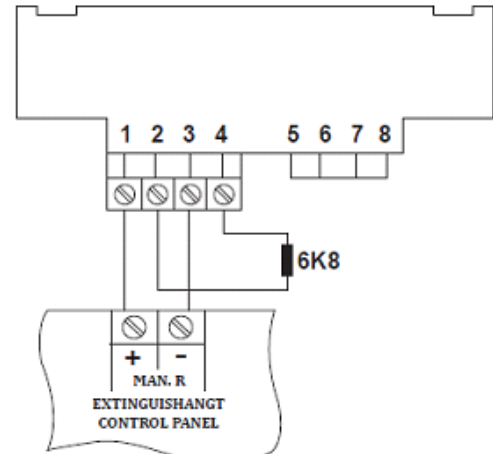

Extinguishing release input

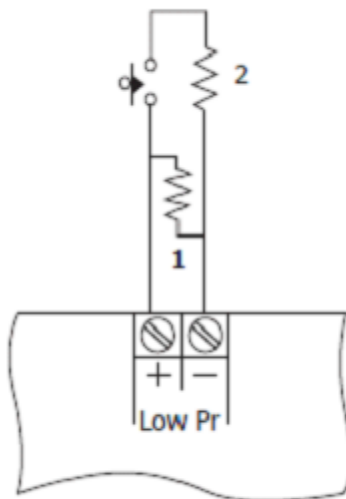

Low pressure input

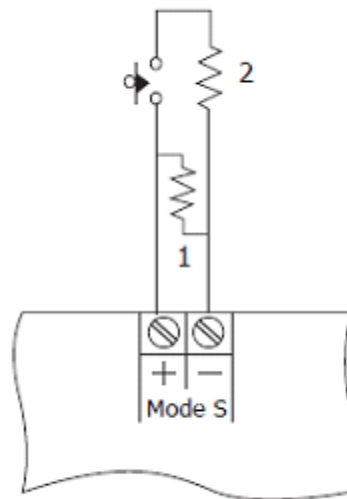

Extinguishing condition switch input