



Modbus Installation and operating instructions for the sensors

VA 500 / VA 520, VA525 und VA 550 / VA 570



I. Foreword

Dear customer,

thank you very much for deciding in favour of the VA 500 / VA 520 / VA 525 /VA 550 / VA570. Please read this installation and operation manual carefully before mounting and initiating the device and follow our advice. A riskless operation and a correct functioning of the VA 500 / VA 520 / VA 525 / VA 550 / VA570 are only guaranteed in case of careful observation of the described instructions and notes



CS INSTRUMENTS GmbH & Co. KG

Geschäftsstelle Süd/Sales Office South

Zindelsteiner Str. 15

D-78052 VS-Tannheim

Tel.: +49 (0) 7705 978 99 0

Fax: +49 (0) 7705 978 99 20

Mail: info@cs-instruments.com

Web: <http://www.cs-instruments.com>

Geschäftsstelle Nord/Sales Office North

Am Oxer 28c

D-24955 Harrislee

Tel.: +49 (0) 461 700 20 25

Fax: +49 (0) 461 700 20 26

Mail: info@cs-instruments.com

Web: <http://www.cs-instruments.com>

II. Table of Content

I. Foreword	2
II. Table of Content	3
1 Instructions	4
1.1 Definition and abbreviation	4
1.2 References	4
2 Technical data Modbus VA 5xx	5
2.1 VA 5xx MODBUS RTU specificationn	5
2.1 General Modbus Information	5
2.1.1 Serial transmission modes (RTU)	5
3 Installation	6
3.1 RS485 Bus Wiring (Modbus RTU) –VA 500 / VA520	6
3.1.1 Termination VA 500 / VA 520	6
3.1.2 Bias	6
3.2 RS485 Bus Verdrahtung (Modbus RTU) – Anschlussplan VA 550 / VA570	7
3.2.1 Termination VA 550 / VA 570	7
3.2.2 Bias	7
4 Modbus RTU communication settings	8
4.1 Accessing and changing Modbus settings	8
4.2 Modbus RTU communication settings	8
5 Modbus TCP	8
6 Modbus addressing model	9
6.1 Function Code 3 (Read holding register)	9
6.2 Function code 16 (Write multiple registers)	10
7 Modbus Holding Register	11
7.1 Basic Values Register (1...1000)	11
7.2 Values register (1001....1500)	12
7.3 Device settings register	22
7.3.1 Modbus Settings (2001...2005)	22
7.3.2 Display Settings (2007...2009)	22
7.3.3 Device Settings (2021...2063)	23
7.4 Gas names	26
7.5 MBus Register	27
7.6 Data format test register (64001... 64003)	27
7.7 Unit Index table	28
8 Appendix	28
8.1 APPENDIX A - Exception codes	28

1 Instructions

This manual is intended to provide instructions for the installation and use of the VA 5xx MODBUS function. The VA 5xx MODBUS function can let the MODBUS master device to read out the online measurement values.

This manual is not intended to be a complete tutorial on the MODBUS RTU protocol, and it is assumed the end user already has a general working knowledge of MODBUS RTU Communications, especially in respect of master station configuration and operation. However an overview is included in the following section to explain some of the fundamental aspects of the protocol.

1.1 Definition and abbreviation

CRC	Cyclic Redundancy Check Used for error—checking in MODBUS RTU. See appendix
Modbus Master	A MODBUS device, which is able to access data in one or more connected MODBUS slaves
Modbus Slave	A MODBUS device, which is able to respond to requests from a single MODBUS master
Modbus Address	Throughout this document the following notation is used to address MODBUS RTU registers see chapter 8 Addressing: Holding Register 1009 is addressed in messages by 1008
PDU	MODBUS protocol data unit
ADU	MODBUS application data unit
MBAP	MODBUS application protocol
RS485	Refers to the 2—wire communication standard defined by EIA/TIA-485. (Physical layer)
Ethernet	

1.2 References

1. MODBUS over Serial Line Specification and Implementation Guide V1.02
modbus.org 2006 Dec 20
2. MODBUS APPLICATION PROTOCOL SPECIFICATION V1.1b modbus.org
2006 Dec 28
3. MODBUS Messaging on TCP/IP implementation Guide V1.0b
2006 Oct 34
4. Instruction manuals VA 5xx

2 Technical data Modbus VA 5xx

2.1 VA 5xx MODBUS RTU specification

Device type	Slave
Baud Rates	1200,2400, 4800, 9600, 19200, 38400, 57600, 115200 bps
Device address range	1...247
Electrical Interface	RS485, 2 wire
Protocol	RTU
Supported function code	3 read holding register 16 write multiple register
Broadcast	No
Standard	Modbus over serial line V1.02

2.1 General Modbus Information

The VA5xx Modbus module complies with the Modbus serial line protocol [Reference 1]. Among other things, this implies a **master-slave** protocol at level 2 of the OSI model. One node (the master) issues explicit commands to one of the „slave“-nodes and processes responses. Slave nodes will not transmit data without a request from the master node, and do not communicate with other slaves.

Modbus is a mono **master system**, which means that only one **master** can be connected at the time.

2.1.1 Serial transmission modes (RTU)

The VA 5xx Modbus mode support only one serial transmission modes; the RTU mode. The transmission mode defines the bit contents of message fields transmitted serially on the line. It determines how information is packed into the message fields and decoded.

The transmission mode and serial port parameters must be the same for all devices on a Modbus serial line.

RTU mode Modbus Application Data Unit (ADU) frame is shown below, and is valid for both requests and responses.

Slave address	Function code	Data	CRC
1 byte	1byte	0 up to 252 byte(s)	2 bytes

Table 1

Further details of the Modbus protocol can be found in Reference 1 and 2.

3 Installation

3.1 RS485 Bus Wiring (Modbus RTU) –VA 500 / VA520 / VA 525

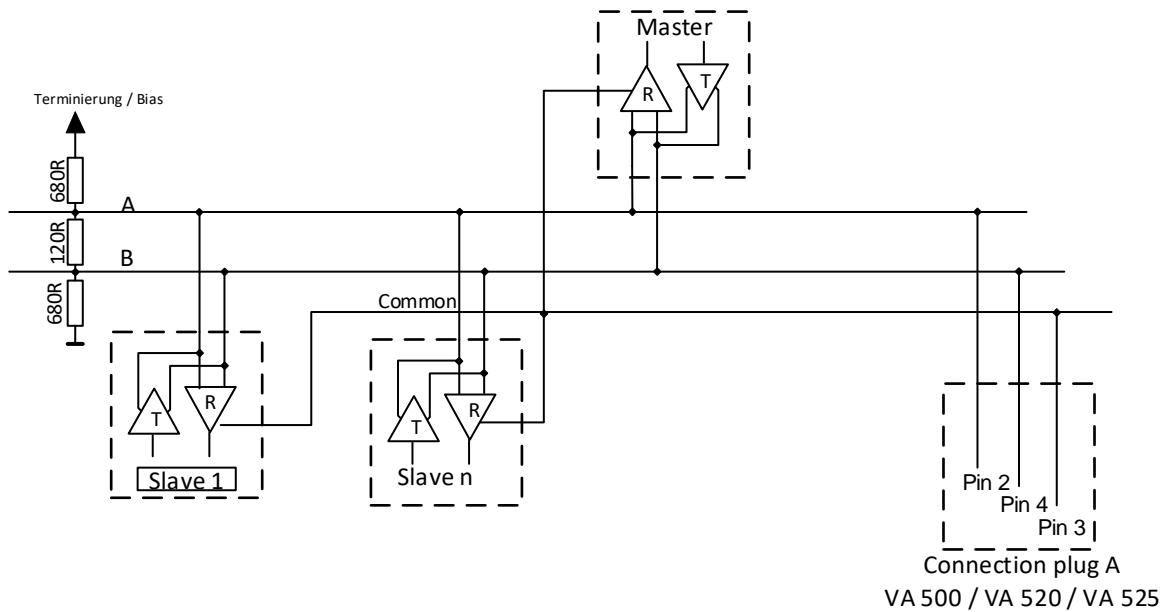

3.1.1 Termination VA 500 / VA 520 / VA 525

Note: In case the VA 500 / VA 520 / VA 525 is the last device in the RS485 network then a termination is required. To be done either with

- a.) Internal DIP Switch
- b.) 120R between (between Pin 2 and Pin 4) of connector plug A

3.1.2 Bias

In order to avoid undefined bus levels, at any location on the bus, a bias network, one resistor to VCC (Modbus A) as well as to GND (Modbus B), has to be used.

3.2 RS485 Bus Verdrahtung (Modbus RTU) – Anschlussplan VA 550 / VA570

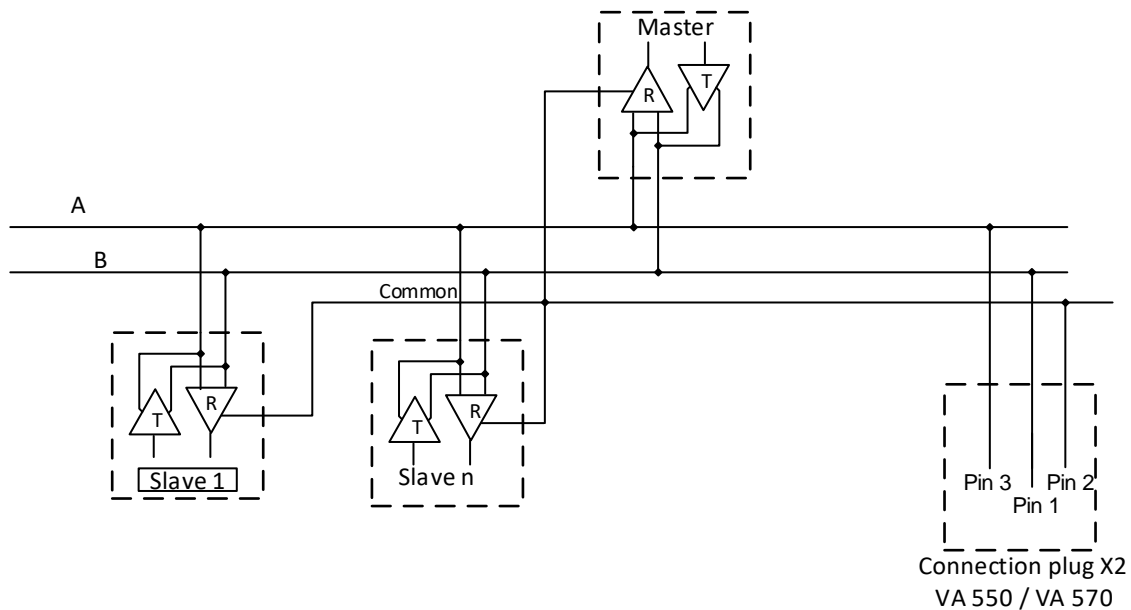

3.2.1 Termination VA 550 / VA 570

In case the VA 550 / VA 570 is the last device in the RS485 network then a termination with 120R between (between Pin 1 and Pin 3) at connector X2 is necessary.

3.2.2 Bias

In order to avoid undefined bus levels, at any location on the bus, a bias network, one resistor to VCC (Modbus A) as well as to GND (Modbus B), has to be used.

Bus cable:

Only cables according to the recommendations of EIA 485 standard should be used. A maximum of 64 devices may be connected to one segment. The bus cable must be laid at a distance of at least 20 cm from other cables. It should be laid in a separate, conductive, and earthed cable trunking. It must be ensured that no potential differences occur between the individual devices on the bus.

3.3 Cable specification:

Impedance:	135 -165 Ohm @ 3 to 20 Mhz
Cable capacity:	< 30pF/m
Cable diameter:	> 0.64 mm
Cross section:	> 0.34 mm ² , conforms to AWG 22
Loop resistance	< 110 Ohm per km
Screening:	Cu shielding braid or shielding braid and shielding foil

4 Modbus RTU communication settings

Before communication with the master, baudrate, address, and framing must be defined

4.1 Accessing and changing Modbus settings

The Modbus communication settings could be changed by using either the PC service software from CS Instruments or by sensors with display in the Modbus setup menu.

Note:

It is recommended **NOT** to use the default address in a multi-slave network. It is of great importance to ensure at the time of the procedure of device addressing, that there is not two devices with the same address. In such a case, an abnormal behaviour of the whole serial bus can occur, the master being then in the impossibility to communicate with all present slaves on the bus.

4.2 Modbus RTU communication settings

Device type	Slave
Baud Rates	1200,2400, 4800, 9600, 19200, 38400, 57600, 115200 bps
Device address range	1...247
Electrical Interface	RS485, 2 wire
Protocol	RTU
Supported function code	3 read holding register 16 write multiple register
Broadcast	No
Standard	Modbus over serial line V1.02

5 Modbus TCP

Modbus communication requires the establishment of a TCP connection between a client (e.g. PC) and the sensor. The TCP port 502 reserved for Modbus is normally used for communication. However, the user can also configure a different port number.

If a firewall is arranged between sensor and client, it must be ensured that the configured TCP port is enabled.

6 Modbus addressing model

The VA 5xx RS485 Modbus allows read/write access according chapter 8
 Not defined registers are not accessible / not supported.

Byte Order:

The size of each Modbus-register is 2 Byte. For a 32 bit value two Modbus register will be read out by the VA 5xx. Accordingly for a 16bit Value only one register is read.

Data format VA 5xx:

Single Word

	HByte	LByte	
18 =>	00	12	
Data Order	1. Byte	2. Byte	
A (AB)	00	12	Big endian
B (BA)	12	00	Little endian

Double Word

	HWord		LWord		
	HByte	LByte	HByte	LByte	
29235175522 =>	AE	41	56	52	
Data Order	1.Byte	2.Byte	3.byte	4.Byte	
A-B-C-D	AE	41	56	52	Big endian
D-C-B-A	52	56	41	AE	Little endian
B-A-D-C	41	AE	52	56	
C-D-A-B	56	52	AE	41	

For verification of a correct data format please read out register 64000 or 64004. Result should be:

Register 64000: Long Integer Value =1 000 000

Register 64002: Float Value = 1 000 000.0

6.1 Function Code 3 (Read holding register)

General exceptions:

- Requesting less than 1 or more than 125 registers => Exception 3 (Illegal data value)
- Requesting more than max. message size (27 registers) => Exception 2 (Illegal data address)
- Requesting data out of defined range of registers chapter 8 => Exception 2 (Illegal data address)

Application exceptions:

- Application errors => Exception 4 (Slave device error)

Holes/register alignment:

- The read command always returns data if no exception is given. Bad start/end alignment will result in only parts of the data item being read.

6.2 Function code 16 (Write multiple registers)

In general, only status register (register 2001 – 2064) are writable.

General exceptions:

- Writing less than 1 or more than 63 registers => Exception 3 (Illegal data value)
- If Byte Count is not exactly 2 times NoOfRegisters => Exception 3 (Illegal data value)
- Exceeding max. message size (27 registers) => Exception 2 (Illegal data address)
- Writing data out of defined register range chapter 8 =>Exception 2 (Illegal data address)

Application exceptions:

- Application errors => Exception 4 (Slave device error)
- Application errors include writing to ReadOnly holding registers

Holes / register alignment:

- If start-address is not the start of a mapped holding register => Exception 2 (Illegal data address)
- Writing to holes is allowed (ie ignored - and no exception occurs) — except for the condition described above

7 Modbus Holding Register

7.1 Basic Values Register (1...1000)

Modbus Register	Modbus Address	No.of Byte	Data Type	Description	Default Setting	Read Write	Unit /Comment
1	0	4	UInt32	Serial Number	0	R	
3	2	4	UInt32	Software Version	0	R	<code>sprintf(str,"%u.%02u",hw>>16,hw&0xffff);</code>
5	4	4	UInt32	Hardware Version	0	R	<code>sprintf(str,"%u.%02u",hw>>16,hw&0xffff);</code>
7	6	4	UInt32		0	R	
9	8	4	UInt32	Production Date	0	R	Unix Time
11	10	4	UInt32	Calibration Date	0	R	Unix Time
13	12	4	UInt32	Ordering Number	0	R	
15	14	4	UInt32	RunTime	0	R	Value in seconds
17	16	4	UInt32		0	R	
19	18	4	UInt32	Atex Number	0	R	
21	20	4	UInt32	Curve Version	0	R	<code>sprintf(str,"%u.%02u",hw>>16,hw&0xffff);</code>
23	22	8	String	Brand Name	0	R	
27	26	4	UInt32	LockSettings	0	R	0 = NoLock, 1 = DiameterLock, 2 = CounterLock, 3 = RefConditionsLock
29	28	4	UInt32	OptionBoard	0	R	Bit Mask 0 = no option 1 = 4-20mA 2 = Ethernet 4 = Mbus 8 = ProfiBus 16 = SDI 32 = Pressure 64 = Direction
31	30	4	Dword	Variant	x	R	
33	32	8	String	Company Name	x	R	
37	36	4	Dword	OptionBoard HardwareVersion (if available)	x	R	<code>sprintf(str,"%u.%02u",hw>>16,hw&0xffff);</code>
39	38	4	Dword	OptionBoard SoftwareVerision (falls verfügbar)	x	R	<code>sprintf(str,"%u.%02u",hw>>16,hw&0xffff);</code>

7.2 Values register (1001....1600)

For the bi-directional sensors VA500B and VA520B refer to note on page 21.

Modbus Register	Modbus Address	No.of Byte	Data Type	Description	Default	Read Write	Unit /Comment
1001	1000	4	Float	Flow as shown in Display		R	
1003	1002	4	UInt32	Total Counter before comma as shown in Display		R	
1005	1004	4	Float	Total Counter after comma as shown in Display		R	
1007	1006	4	Float	Velocity as shown in Display		R	
1009	1008	4	Float	Gas Temperature as shoed in Display		R	
1011	1010	4	Float	Internal Temperature as shown in Display		R	
1013	1012	4	Float	Supply Voltage		R	
1015	1014	4	Float	Max Speed (at Velocity Unit as shown in Display)		R	
1017	1016	4	Float	Max Flow (at Flow Unit as shown in Display)		R	
1019	1018	4	Float	Status of Sensor		R	noError 0x0000 NotCalibrated 0x0001 LowVoltage 0x0002 TempError 0x0004 HeatError 0x0008 IntError 0x000a HeatNotCal 0x0020 AmbNotCal 0x0040 TmpOutofRange 0x0080 Direction 0x0100 LowVolt4_20 0x0200 NextCalElapsed 0x0400 Direction not Cal 0x0800
1021	1020	4	Float	Flow Min at Flow Unit in Display since Clear Min/Max		R	
1023	1022	4	Float	Flow Max at Flow Unit in Display since Clear Min/Max		R	
1025	1024	4	Float	Flow AV at Flow Unit in Display		R	AV over the Time from AV Time Setup 1 to 1440 minutes
1027	1026	4	Float	Average Consumption at Consumption Unit in Display		R	Consumption over Time at AVTime Setup
1029	1028	4	Float	Gas Temp Min at Temp. Unit in Display since Clear Min/Max		R	
1031	1030	4	Float	Gas Temp Max at Temp. Unit in Display since Clear Min/Max		R	
1033	1032	4	Float	Gas Temp AV at Temp. Unit in Display		R	AV over the Time from AVTime Setup 1 to 1440 minutes
1035	1034	4	Float	Velocity Min at Velocity Unit in Display since Clear Min/Max		R	
1037	1036	4	Float	Velocity Max at Velocity Unit in Display since Clear Min/Max		R	
1039	1038	4	Float	Velocity AV at Velocity Unit in Display		R	AV over the Time from AVTime Setup 1 to 1440 minutes

Modbus Register	Modbus Address	No.of Byte	Data Type	Description	Default	Read Write	Unit /Comment
1041	1040	4	Float/Dword	Incremented Pulses since setup pulse	x	R	
1043	1042	4	Float/Dword	Systempressure (at Pressure Unit showed in Display)	x	R	Value only available with pressure option
1045	1044	4	Float/Dword	Systempressure Min at Pressure Unit in Display since Clear Min/Max	x	R	Value only available with pressure option
1047	1046	4	Float/Dword	Systempressure Max at Pressure Unit in Display since Clear Min/Max	x	R	Value only available with pressure option
1049	1048	4	Uint/Dword	Total Counter bevore comma as showed in Display (left side)	x	R	only available in Direction Sensor Vaxxxx
1051	1050	4	Float/Dword	Total Counter after comma as showed in Display (left side)	x	R	only available in Direction Sensor Vaxxxx
1053	1052	4	Uint/Dword	Total Counter bevore comma as showed in Display (left side + right side)	x	R	only available in Direction Sensor Vaxxxx
1055	1054	4	Float/Dword	Total Counter after comma as showed in Display (left side + right side)	x	R	only available in Direction Sensor Vaxxxx
1057	1056	4	Float/Dword	reserved	x	R	
to							
1099	1078	4	Float/Dword	reserved	x	R	

Modbus Register	Modbus Address	No.of Byte	Data Type	Description	Default	Read Write	Unit /Comment
1101	1100	4	Float	Flow in m³/h		R	
1103	1102	4	Float	Flow Min in m ³ /h since last Clear Min/Max		R	
1105	1104	4	Float	Flow Max in m ³ /h since last Clear Min/Max		R	
1107	1106	4	Float	Flow AV in m ³ /h		R	Average for time period defined in AVTime Setup „1 to 1440 minutes“
1109	1108	4	Float	Flow in Nm³/h		R	
1111	1110	4	Float	Flow Min in Nm ³ /h since last Clear Min/Max		R	
1113	1112	4	Float	Flow Max in Nm ³ /h since last Clear Min/Max		R	
1115	1114	4	Float	Flow AV in Nm ³ /h		R	Average for time period defined in AVTime Setup „1 to 1440 minutes“
1117	1116	4	Float	Flow in m³/min		R	
1119	1118	4	Float	Flow Min in m ³ /min since last Clear Min/Max		R	
1121	1120	4	Float	Flow Max in m ³ /min since last Clear Min/Max		R	
1123	1122	4	Float	Flow AV in m ³ /min		R	Average for time period defined in AVTime Setup „1 to 1440 minutes“
1125	1124	4	Float	Flow in Nm³/min		R	
1127	1126	4	Float	Flow Min in Nm ³ /min since last Clear Min/Max		R	
1129	1128	4	Float	Flow Max in Nm ³ /min since last Clear Min/Max		R	
1131	1130	4	Float	Flow AV in Nm ³ /min		R	Average for time period defined in AVTime Setup „1 to 1440 minutes“
1133	1132	4	Float	Flow in ltr/h		R	
1135	1134	4	Float	Flow Min in ltr/h since last Clear Min/Max		R	
1137	1136	4	Float	Flow Max in ltr/h since last Clear Min/Max		R	
1139	1138	4	Float	Flow AV in ltr/h		R	Average for time period defined in AVTime Setup „1 to 1440 minutes“

Modbus Register	Modbus Address	No.of Byte	Data Type	Description	Default	Read Write	Unit /Comment
1141	1140	4	Float	Flow in Nltr/h		R	
1143	1142	4	Float	Flow Min in Nltr/h since last Clear Min/Max		R	
1145	1144	4	Float	Flow Max in Nltr/h since last Clear Min/Max		R	
1147	1146	4	Float	Flow AV in Nltr/h		R	AV over the Time from AVTime Setup 1 to 1440 minutes
1149	1148	4	Float	Flow in ltr/min		R	
1151	1150	4	Float	Flow Min in ltr/min since last Clear Min/Max		R	
1153	1152	4	Float	Flow Max in ltr/min since last Clear Min/Max		R	
1155	1154	4	Float	Flow AV in ltr/min		R	Average for time period defined in AVTime Setup „1 to 1440 minutes“
1157	1156	4	Float	Flow in Nltr/min		R	
1159	1158	4	Float	Flow Min in Nltr/min since last Clear Min/Max		R	
1161	1160	4	Float	Flow Max in Nltr/min since last Clear Min/Max		R	
1163	1162	4	Float	Flow AV in Nltr/min		R	Average for time period defined in AVTime Setup „1 to 1440 minutes“
1165	1164	4	Float	Flow in ltr/s		R	
1167	1166	4	Float	Flow Min in ltr/s since last Clear Min/Max		R	
1169	1168	4	Float	Flow Max in ltr/s since last Clear Min/Max		R	
1171	1170	4	Float	Flow AV in ltr/s		R	Average for time period defined in AVTime Setup „1 to 1440 minutes“
1173	1172	4	Float	Flow in Nltr/s		R	
1175	1174	4	Float	Flow Min in Nltr/s since last Clear Min/Max		R	
1177	1176	4	Float	Flow Max in Nltr/s since last Clear Min/Max		R	
1179	1178	4	Float	Flow AV in Nltr/s		R	Average for time period defined in AVTime Setup „1 to 1440 minutes“
1181	1180	4	Float	Flow in cfm		R	
1183	1182	4	Float	Flow Min in cfm since last Clear Min/Max		R	
1185	1184	4	Float	Flow Max in cfm since last Clear Min/Max		R	
1187	1186	4	Float	Flow AV in cfm		R	Average for time period defined in AVTime Setup „1 to 1440 minutes“

Modbus Register	Modbus Address	No.of Byte	Data Type	Description	Default	Read Write	Unit /Comment
1189	1188	4	Float	Flow in Ncfm		R	
1191	1190	4	Float	Flow Min in Ncfm since last Clear Min/Max		R	
1193	1192	4	Float	Flow Max in Ncfm since last Clear Min/Max		R	
1195	1194	4	Float	Flow AV in Ncfm		R	Average for time period defined in AVTime Setup „1 to 1440 minutes“
1197	1196	4	Float	Flow in kg/h		R	
1199	1198	4	Float	Flow Min in kg/h since last Clear Min/Max		R	
1201	1200	4	Float	Flow Max in kg/h since last Clear Min/Max		R	
1203	1202	4	Float	Flow AV in kg/h		R	Average for time period defined in AVTime Setup „1 to 1440 minutes“
1205	1204	4	Float	Flow in kg/min		R	
1207	1206	4	Float	Flow Min in kg/min since last Clear Min/Max		R	
1209	1208	4	Float	Flow Max in kg/min since last Clear Min/Max		R	
1211	1210	4	Float	Flow AV in kg/min		R	Average for time period defined in AVTime Setup „1 to 1440 minutes“
1213	1212	4	Float	Flow in kg/s		R	
1215	1214	4	Float	Flow Min in kg/s since last Clear Min/Max		R	
1217	1216	4	Float	Flow Max in kg/s since last Clear Min/Max		R	
1219	1218	4	Float	Flow AV in kg/s		R	Average for time period defined in AVTime Setup „1 to 1440 minutes“
1221	1220	4	Float	Flow in kW		R	
1223	1222	4	Float	Flow Min in kW since last Clear Min/Max		R	
1225	1224	4	Float	Flow Max in kW since last Clear Min/Max		R	
1227	1226	4	Float	Flow AV in kW		R	Average for time period defined in AVTime Setup „1 to 1440 minutes“

Modbus Register	Modbus Address	No.of Byte	Data Type	Description	Default	Read Write	Unit /Comment
1269	1268	4	UInt32	Consumption m³ before comma	x	R	
1271	1270	4	Float	Consumption m ³ after comma	x	R	
1273	1272	4	Float	Consumption m ³ AV	x	R	Average for time period defined in AVTime Setup „1 to 1440 minutes“
1275	1274	4	UInt32	Consumption Nm³ before comma	x	R	
1277	1276	4	Float	Consumption Nm ³ after comma	x	R	
1279	1278	4	Float	Consumption Nm ³ AV	x	R	Average for time period defined in AVTime Setup „1 to 1440 minutes“
1281	1280	4	UInt32	Consumption ltr before comma	x	R	
1283	1282	4	Float	Consumption ltr after comma	x	R	
1285	1284	4	Float	Consumption ltr AV	x	R	Average for time period defined in AVTime Setup „1 to 1440 minutes“
1287	1286	4	UInt32	Consumption Nltr before comma	x	R	
1289	1288	4	Float	Consumption Nltr after comma	x	R	
1291	1290	4	Float	Consumption Nltr AV	x	R	Average for time period defined in AVTime Setup „1 to 1440 minutes“
1293	1292	4	UInt32	Consumption cf before comma	x	R	
1295	1294	4	Float	Consumption cf after comma	x	R	
1297	1296	4	Float	Consumption cf AV	x	R	Average for time period defined in AVTime Setup „1 to 1440 minutes“
1299	1298	4	UInt32	Consumption Ncf before comma	x	R	
1301	1300	4	Float	Consumption Ncf after comma	x	R	
1303	1302	4	Float	Consumption Ncf AV	x	R	Average for time period defined in AVTime Setup „1 to 1440 minutes“
1305	1304	4	UInt32	Consumption kg before comma	x	R	
1307	1306	4	Float	Consumption kg after comma	x	R	
1309	1308	4	Float	Consumption kg AV	x	R	Average for time period defined in AVTime Setup „1 to 1440 minutes“
1311	1310	4	UInt32	Consumption kWh before comma	x	R	
1313	1312	4	Float	Consumption kWh after comma	x	R	
1315	1314	4	Float	Consumption kWh AV	x	R	Average for time period defined in AVTime Setup „1 to 1440 minutes“

Modbus Register	Modbus Address	No.of Byte	Data Type	Description	Def ault	Read Write	Unit /Comment
1347	1346	4	Float	Velocity m/s		R	
1349	1348	4	Float	Velocity Min m/s since last Clear Min/Max		R	
1351	1350	4	Float	Velocity Max m/s since last Clear Min/Max		R	
1353	1352	4	Float	Velocity AV m/s		R	Average for time period defined in AVTime Setup „1 to 1440 minutes“
1355	1354	4	Float	Velocity Nm/s		R	
1357	1356	4	Float	Velocity Min Nm/s since last Clear Min/Max		R	
1359	1358	4	Float	Velocity Max Nm/s since last Clear Min/Max		R	
1361	1360	4	Float	Velocity AV Nm/s		R	Average for time period defined in AVTime Setup „1 to 1440 minutes“
1363	1362	4	Float	Velocity Ft/min		R	
1365	1364	4	Float	Velocity Min Ft/min since last Clear Min/Max		R	
1367	1366	4	Float	Velocity Max Ft/min since last Clear Min/Max		R	
1369	1368	4	Float	Velocity AV Ft/min		R	Average for time period defined in AVTime Setup „1 to 1440 minutes“
1371	1370	4	Float	Velocity NFt/min		R	
1373	1372	4	Float	Velocity Min NFt/min since last Clear Min/Max		R	
1375	1374	4	Float	Velocity Max NFt/min since last Clear Min/Max		R	
1377	1376	4	Float	Velocity AV NFt/min		R	Average for time period defined in AVTime Setup „1 to 1440 minutes“
1419	1418	4	Float	GasTemp °C		R	
1421	1420	4	Float	GasTemp Min °C since Clear Min/Max		R	
1423	1422	4	Float	GasTemp Max °C since Clear Min/Max		R	
1425	1424	4	Float	GasTemp AV °C		R	Average for time period defined in AVTime Setup „1 to 1440 minutes“
1427	1426	4	Float	GasTemp °F		R	
1429	1428	4	Float	GasTemp Min °F since Clear Min/Max		R	
1431	1430	4	Float	GasTemp Max °F since Clear Min/Max		R	
1433	1432	4	Float	GasTemp AV °F		R	Average for time period defined in AVTime Setup „1 to 1440 minutes“

Modbus Register	Modbus Address	No.of Byte	Data Type	Description	Def ault	Read Write	Unit /Comment
1475	1474	4	Float	Systempressure mbar	x	R	Value only available with pressure option
1477	1476	4	Float	systempressure Min mbar since Clear Min/Max	x	R	Value only available with pressure option
1479	1478	4	Float	systempressure Max mbar since Clear Min/Max	x	R	Value only available with pressure option
1481	1480	4	Float	Systempressure bar	x	R	Value only available with pressure option
1483	1482	4	Float	systempressure Min bar since Clear Min/Max	x	R	Value only available with pressure option
1485	1484	4	Float	systempressure Max bar since Clear Min/Max	x	R	Value only available with pressure option
1487	1486	4	Float	Systempressure psi	x	R	Value only available with pressure option
1489	1488	4	Float	systempressure Min psi since Clear Min/Max	x	R	Value only available with pressure option
1491	1490	4	Float	systempressure Max psi since Clear Min/Max	x	R	Value only available with pressure option

Modbus Register	Modbus Address	No.of Byte	Data Type	Description	Def ault	Read Write	Unit /Comment
1533	1532	4	UInt	Consumption m ³ bevore comma (left side)	x	R	only available in Direction Sensor VA 509
1535	1534	4	Float	Consumption m ³ after comma (left side)	x	R	
1537	1536	4	UInt	Consumption total m ³ bevore comma (left side + right side)	x	R	
1539	1538	4	Float	Consumption total m ³ after comma (left side + right side)	x	R	
1541	1540	4	UInt	Consumption Nm ³ bevore comma (left side)	x	R	
1543	1542	4	Float	Consumption Nm ³ after comma (left side)	x	R	
1545	1544	4	UInt	Consumption total Nm ³ bevore comma (left side + right side)	x	R	
1547	1546	4	Float	Consumption total Nm ³ after comma (left side + right side)	x	R	
1549	1548	4	UInt	Consumption ltr bevore comma (left side)	x	R	
1551	1550	4	Float	Consumption ltr after comma (left side)	x	R	
1553	1552	4	UInt	Consumption total ltr bevore comma (left side + right side)	x	R	
1555	1554	4	Float	Consumption total ltr after comma (left side + right side)	x	R	
1557	1556	4	UInt	Consumption Nltr bevore comma (left side)	x	R	
1559	1558	4	Float/	Consumption Nltr after comma (left side)	x	R	
1561	1560	4	UInt	Consumption total Nltr bevore comma (left side + right side)	x	R	
1563	1562	4	Float	Consumption total Nltr after comma (left side + right side)	x	R	
1565	1564	4	UInt	Consumption Cf bevore comma (left side)	x	R	
1567	1566	4	Floatd	Consumption Cf after comma (left side)	x	R	
1569	1568	4	UInt	Consumption total Cf bevore comma (left side + right side)	x	R	
1571	1570	4	Float	Consumption total Cf after comma (left side + right side)	x	R	
1573	1572	4	UInt	Consumption NCf bevore comma (left side)	x	R	
1575	1574	4	Float	Consumption NCf after comma (left side)	x	R	
1577	1576	4	UInt	Consumption total NCf bevore comma (left side + right side)	x	R	

Modbus Register	Modbus Address	No.of Byte	Data Type	Description	Def ault	Read Write	Unit /Comment
1579	1578	4	Float/Dword	Consumption total NCf after comma (left side + right side)	x	R	only available in Direction Sensor VA 509
1581	1580	4	UInt/Dword	Consumption kg bevore comma (left side)	x	R	
1583	1582	4	Float/Dword	Consumption kg after comma (left side)	x	R	
1585	1584	4	UInt/Dword	Consumption total kg bevore comma (left side + right side)	x	R	
1587	1586	4	Float/Dword	Consumption total kg after comma (left side + right side)	x	R	
1589	1588	4	UInt/Dword	Consumption kWh bevore comma (left side)	x	R	
1591	1590	4	Float/Dword	Consumption kWh after comma (left side)	x	R	
1593	1592	4	UInt/Dword	Consumption total kWh bevore comma (left side + right side)	x	R	
1595	1594	4	Float/Dword	Consumption total kWh after comma (left side + right side)	x	R	

Remark:

For sensors VA500B / VA520B (bi-directional) applies:

Values for the "Green" direction can be read from registers 1000 - 1600.

Values for the "Blue" direction can be read from registers 10000 - 11600.

Register address for values in direction "Blue" = Register address in direction "Green" + 9000

Example for consumption in m³

Value for direction "Green" Register Address 1268

Value for direction "Blue" Register address 10268 → (1268 +9000 = 10268)

7.3 Device settings register

7.3.1 Modbus Settings (2001...2005)

Modbus Register	Modbus Address	No.of Byte	Data Type	Description	Default Setting	Read Write	Unit /Comment
2001	2000	2	UInt16	Modbus ID	1	R/W	Modbus ID 1...247
2002	2001	2	UInt16	Baudrate	4	R/W	0 = 1200 1 = 2400 2 = 4800 3 = 9600 4 = 19200 5 = 38400 6 = 57600 7 = 115200
2003	2002	2	UInt16	Parity	1	R/W	0 = none 1 = even 2 = odd
2004	2003	2	UInt16	Number of Stopbits		R/W	0 = 1 Stop Bit 1 = 2 Stop Bit
2005	2004	2	UInt16	Word Order	0xABCD	R/W	0xABCD = Big Endian 0xCDAB = Middle Endian

7.3.2 Display Settings (2007...2009)

Modbus Register	Modbus Address	No.of Byte	Data Type	Description	Default Setting	Read Write	Unit /Comment
2007	2006	2	UInt16	Display Rotation Auto dimming	0	R/W	bit 0: 0 = 0°, 1 = 180° bit 1: 0 = Autodimm off 1 = Autodimm on bit 2 to 7 reserved bit 8 to 15 Autodimm Time (max. 240 Minutes)"
2008	2007	2	UInt16	BackLight Brightness	80	R/W	0 to 100%
2009	2008	2	UInt16	Language	0	R/W	0 = English 1 = Deutsch 2 = Spanish 3 = French

7.3.3 Device Settings (2021...2063)

Modbus Register	Modbus Address	No.of Byte	Data Type	Description	Default Setting	Read Write	Unit /Comment
2021	2020	16	String	Sensor Location	""	R/W	
2029	2028	4	Uint32	Calibrated GasType as index	0	R/W	index to Get Gas Names as String see chapter 7.4
2031	2030	4	Uint32	GasSubType (only available if Calibrated GasType is Air)	0	R/W	0 = Air 1 = CO2 2 = N2O 3 = N2 4 = O2 5 = NG 6 = AR 7 = He 8 = H2 9 = C3H8 10 = CH4
2033	2032	4	Uint32	Index of Length Unit Unit according Unit Index table	64 (mm)	R/W	
2035	2034	4	Uint32	Index of Flow Unit Unit according Unit Index table	14 (m ³ /h)	R/W	
2037	2036	4	Uint32	Index of Velocity Unit Unit according Unit Index table	10 (m/s)	R/W	
2039	2038	4	Uint32	Index of Consumption Unit according Unit Index table	24 (m ³)	R/W	
2041	2040	4	Uint32	Index of Temperature Unit according Unit Index table	1 (°C)	R/W	
2043	2042	4	Uint32	Index of Pressure Unit according Unit Index table	38 (mbar)	R/W	
2045	2044	4	Float	Pipe diameter in length unit as programmed in Register 2033		R/W	
2047	2046	4	Float	Reference Temperature in Unit programmed in Register 2041	20	R/W	
2049	2048	4	Float	Reference Pressure in Unit programmed in Register 2049	1000	R/W	
2051	2050	4	Float	System Pressure in Unit programmed in Register 2049	5000	R/W	
2053	2052	4	Float	Zero Point of Velocity in Unit programmed in Register 2037	0	R/W	
2055	2054	4	Float	Min Velocity in Unit programmed in Register 2037	0	R/W	
2057	2056	4	Float	LowPass Filter Time for Flow and Velocity in ms	100	R/W	
2059	2058	4	Uint32	Average Time to Build Average (1 to 1440 minutes)	60	R/W	
2061	2060	4	Float	HeatRating for Flammable gases at 0°C / 1013.25mbar	0	R/W	
2063	2062	4	Uint32	next Cal Date	CalDate + 2 Years	R/W	UnixTime

Modbus Register	Modbus Address	No.of Byte	Data Type	Description	Default Setting	Read Write	Unit /Comment
2081	2080	4	Float	Relais Mode as index	1	R/W	0 = none 1 = Puls 2 = Alarm
2083	2082	4	Float	Unit Puls from Unit Table	U_m3	R/W	U_m3 U_ltr U_cf U_kg
2085	2084	4	Float	Pulse Value (value where is generated a new puls)	1	R/W	
2087	2086	4	Float	Pulse Polarity	1	R/W	0 = neg 1 = pos
2089	2088	4	Float	Unit Alarm from Unit Table	U_GRA D_C	R/W	U_m_s U_m3_h U_ltr_s U_cfm U_kg_min U_kg_s U_GRAD_C U_GRAD_F
2091	2090	4	Float	Alarm Value in Unit above	25	R/W	
2093	2092	4	Float	Alarm Hysteresis in Unit above	1	R/W	
2095	2094	4	Float	Alarm at overshoot or undershoot as index	1	R/W	0 = undershot 1 = overshoot
2113	2112	4	Float	Reset to Factory Defaults		W	send Serial Number to this adr. to set factory defaults
2115	2114	4	Float	Consumption at programmed unit above		W	if not locked, value to set consumption
2117	2116	4	Float	Reset Min/Max Values		W	
2119	2118	4	Float	Reset AV Values		W	
2121	2120	4	Float	Temperature Correction Value at unit programmed above		R/W	Write the actual measured Temperature value to this register at read the offset to internal temperature is returned
2123	2122	4	Float	Set or Clear RemoteControl State		R/W	0 = cleared all other means remote controlled
2125	2124	4	Float	User offset pressure		R/W	only with pressure option available
2127	2126	4	Float	Consumption (left side) at programmed unit above		R/W	only available in Direction Sensor VA509

7.3.4 Analog 4...20mA Register

Modbus Register	Modbus Address	No. of Byte	Data Type	Description	Default Setting	Read Write	Unit /Comment
2201	2200	4	UInt32	4-20mA CH1 Selected Value as index	1 or 2	R/W	0 = not used 1 = Flow 2 = Velocity 3 = Temperature
2203	2202	4	UInt32	4-20mA CH1 Unit index from unit table for above selected Value	U_m3_h (VA520 & VA570) U_m_s (VA500 & VA550)	R/W	Flow: U_m3_h,U_Nm3_h,U_m3_min,U_Nm3_min,U_ltr_h,U_Nltr_h,U_ltr_min,U_Nl_min,U_ltr_s,U_Nl_s,U_cfm,U_Ncfm,U_kg_h,U_kg_min,U_kg_s,U_kW Velocity: U_m_s,U_Nm_s,U_Ft_min,U_Nft_min Temperature: U_GRAD_C,U_GRAD_F
2205	2204	4	UInt32	4-20mA CH1 Auto or Manual Range	0	R/W	0 = AutoRange 1 = Manual Range
2207	2206	4	UInt32	4-20mA CH1 Scale Low	0	R/W	writable only if Manual Range is selected
2209	2208	4	UInt32	4-20mA CH1 Scale High	Max Speed	R/W	writable only if Manual Range is selected
2211	2210	4	UInt32	4-20mA CH2 Selected Value as index	3	R/W	0 = not used 1 = Flow 2 = Velocity 3 = Temperature
2213	2212	4	UInt32	4-20mA CH2 Unit index from unit table for above selected Value	U_GRAD_C	R/W	Flow: U_m3_h,U_Nm3_h,U_m3_min,U_Nm3_min,U_ltr_h,U_Nltr_h,U_ltr_min,U_Nl_min,U_ltr_s,U_Nl_s,U_cfm,U_Ncfm,U_kg_h,U_kg_min,U_kg_s,U_kW Velocity: U_m_s,U_Nm_s,U_Ft_min,U_Nft_min Temperature: U_GRAD_C,U_GRAD_F
2215	2214	4	UInt32	4-20mA CH2 Auto or Manual Range	-20	R/W	0 = AutoRange 1 = Manual Range
2217	2216	4	UInt32	4-20mA CH2 Scale Low	100	R/W	writable only if Manual Range is selected
2219	2218	4	UInt32	4-20mA CH2 Scale High	Max Speed	R/W	writable only if Manual Range is selected
2221	2220	4	UInt32	4-20mA CH1 and CH2 Current on error as index		R/W	0 = is the actual value above 3.8mA or below 20.5mA 1 = 22mA is outputed 2 = 2mA is outputed
2223	2222	4	UInt32	4-20mA number of available channels	1	R	

7.4 Gas names

Modbus Register	Modbus Address	No.of Byte	Data Type	Description	Default Setting	Read Write	Unit /Comment
2501	2500	16	String	Gas at index 0	Air	R	
2509	2508	16	String	Gas at index 1		R	
2517	2516	16	String	Gas at index 2		R	
2525	2524	16	String	Gas at index 3		R	
2533	2532	16	String	Gas at index 4		R	
2541	2540	16	String	Gas at index 5		R	
2549	2548	16	String	Gas at index 6		R	
2557	2556	16	String	Gas at index 7		R	
2565	2564	16	String	Gas at index 8		R	
2573	2572	16	String	Gas at index 9		R	
2581	2580	16	String	Gas at index 10		R	
2589	2588	16	String	Gas at index 11		R	
2597	2596	16	String	Gas at index 12		R	
2605	2604	16	String	Gas at index 13		R	
2613	2612	16	String	Gas at index 14		R	

Address of Gasname register: $(\text{Value register } 2031) * 8 + 2500$

e.g. Value Register 2031 = 1

Address Gasname register: $(1 * 8) + 2500 = \underline{2508}$

7.5 MBus Register

Modbus Register	Modbus Address	No.of Byte	Data Type	Description	Default Setting	Read Write	Unit /Comment
3001	3000	4	Dword	Mbus Primary Address	0x01	R/W	Range 1..255
3003	3002	4	Dword	Mbus ID	0	R/W	Range 0..99999999
3005	3004	4	Dword	Mbus Medium Index	0x0E	R/W	0x00 = Other 0x01 = Oil 0x02 = Electricity 0x03 = Gas 0x04 = Heat 0x05 = Steam 0x06 = Hot Water 0x07 = Water 0x08 = H.C.A. 0x09 = Compressed Air 0x0A = C.L.M. - in 0x0B = C.L.M. - out 0x0C = Hot Water Mode 2 0x0D = Water Mode 2 0x0E = Bus / System 0x0F = Reserved
3007	3006	4	Dword	Mbus Baudrate Index	0x03	R/W	0x00 = 300 0x01 = 600 0x02 = 1200 0x03 = 2400 0x04 = 4800 0x05 = 9600
3009	3008	4	Dword	Mbus Manufacturer	CSI	R/W	$((\text{CHAR}_1 - 64) * 1024) + ((\text{CHAR}_2 - 64) * 32) + (\text{CHAR}_3 - 64)$
3011	3010	4	Dword	Number of Mbus values	1	R/W	Range 0..20
3013	3012	4	Dword	Index of Value #1	0	R/W	
3015	3014	4	Dword	Unit Index for Value #1	14	R/W	
3017	3016	4	Dword	Index of Value #2		R/W	
3019	3018	4	Dword	Unit Index for Value #2		R/W	
3021	3020	4	Dword	Index of Value #3		R/W	
3023	3022	4	Dword	Unit Index for Value #3		R/W	
3025	3024	4	Dword	Index of Value #4		R/W	
3027	3026	4	Dword	Unit Index for Value #4		R/W	
to							
3089	3038	4	Dword	Index of Value #20		R/W	
3091	3040	4	Dword	Unit Index for Value #20		R/W	

7.6 Data format test register (64001... 64003)

Modbus Register	Modbus Address	No.of Byte	Data Type	Description	Default Setting	Read Write	Unit /Comment
64001	64000	4	Dword	1000000	x	R	format test for Dword
64003	64002	4	float	1000000.0	x	R	format test for float

7.7 Unit Index table

Index	Value	Index	Value	Index	Value	Index	Value
1	°C	11	fpm	21	Nltr/min	31	atm°C
2	°F	12	Nm/s	22	Nltr/s	32	atm°F
3	%RH	13	SFPM	23	SCFM	33	pa
4	°Ctd	14	m³/h	24	m³	34	hpa
5	°Ftd	15	m³/min	25	ltr	35	kpa
6	mg/kg	16	ltr/min	26	cf	36	Mpa
7	mg/m³	17	ltr/s	27	Nm³	37	mbar
8	g/kg	18	cfm	28	Nltr	38	bar
9	g/m³	19	Nm³/h	29	SCF	39	psi
10	m/s	20	Nm³/min	30	ppm	40	mV

Index	Value	Index	Value	Index	Value	Index	Value
41	V	51	AVcf/h	61	kVAr	71	ltr/h
42	µV	52	kg/h	62	-	72	Nltr/h
43	kV	53	kg/min	63	€	73	lb/h
44	mA	54	Ohm	64	cts/m³	74	lb/min
45	A	55	Hz	65	W	75	lb/s
46	kg/s	56	%	66	Wh	76	t/h
47	kg	57	kW	67	h	77	t
48	AVm³/h	58	kWh	68	dB	78	lb
49	AVl/h	59	PCS	69	mm	79	SCFH
50	AVkg/h	60	kVA	70	inch	80	cfh

Index	Value	Index	Value	Index	Value	Index	Value
81	g/s						
82	g/min						
83	m						
84	ft						

8 Appendix

8.1 APPENDIX A - Exception codes

The VA 5xx Modbus uses the following exception codes when responding to the master

Exception Code	Exception name
0x01	Illegal function
0x02	Illegal data address
0x03	Illegal data value
0x04	Slave device failure
0x05	Acknowledge
0x06	Slave device busy