



The Industrial Choice.

**Model BSTAB
Belt Driven**



**Model BSTA
Direct Drive**



**TUBEAXIAL FANS,
DIRECT DRIVE & BELT DRIVEN**

Models BSTA / BSTAB

Tubeaxial Fans

Models BSTA / BSTAB

Direct Drive & Belt Driven



Motor Side View of BSTA
Direct Drive Tubeaxial Fan

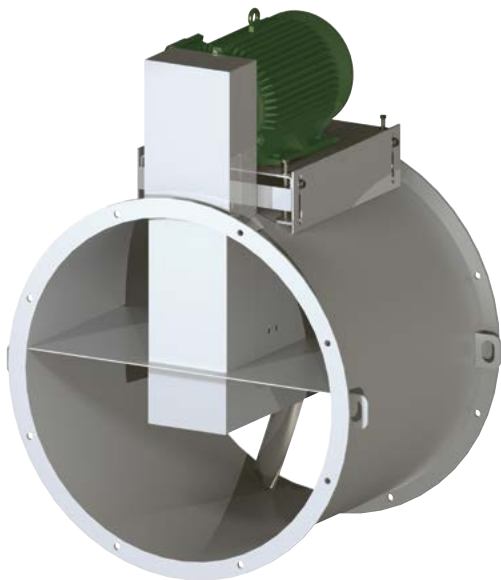

Drive Side View of
BSTAB Belt Driven
Tubeaxial Fan

Aerovent BSTA and BSTAB Tubeaxial Fans are specifically designed for cost effective, reliable air movement in commercial and light industrial ducted and non-ducted applications. Direct and belt drive models are available with cast aluminum propellers to meet specific application requirements.

Sizes and Performance

- Direct drive sizes 14" to 48"
- Belt driven sizes 14" to 54"
- Airflow to 61,000 CFM
- Static pressures to 1½" w.g.

Construction Features

- Die cast aluminum blades and hubs.
- Continuously welded, heavy-gauge, corrosion resistant, enamel coated steel housing.
- Heavy-gauge steel motor and bearing supports provide maximum strength with minimal resistance to airflow.
- Flanged housings with prepunched mounting holes can easily be connected to ductwork.
- Dynamically balanced propellers for quiet, vibration-free operation.
- Designed for continuous duty.
- Available with a wide variety of ODP, TEFC and explosion proof ball bearing motors.
- Extended lube lines are standard on Model BSTAB fans.
- Externally mounted conduit box standard on model BSTA fans.



Aerovent, a Twin City Fan Company certifies that the BSTA/BSTAB Series shown herein is licensed to bear the AMCA Seal. The Ratings shown are based on tests and procedures performed in accordance with AMCA Publication 211 and AMCA Publication 311 and comply with the AMCA Certified Ratings Program.

The AMCA Certified Ratings Seal applies to air and sound performance for Model BSTA Sizes 14B105, 16B105 and 18B105 on page 5 and Model BSTAB Sizes 14B105, 16B105 and 18B105 on pages 9-10.

The AMCA Certified Ratings Seal applies to the Fan Efficiency Grade for Model BSTA Sizes 21B105, 24B105, 30B105, 36B206, 42B304 and 48B304 on pages 6-8 and Model BSTAB Sizes 21B105, 24B105, 30B105, 36B206, 42B304, 48B304 and 54B406 on pages 11-17.

Accessories

Belt Guard

Totally enclosed belt guard protects personnel from rotating components by enclosing the motor sheaves and V-belt drive assembly. (Model BSTAB fans only.)

Motor Cover

A weatherproof motor cover is available on belt driven models to protect the motor and drive components. Motor covers also serve as an OSHA guard to protect personnel from rotating parts and can easily be removed for inspection. (Model BSTAB fans only.)

Inlet Bell

An inlet bell is recommended to minimize entrance losses for installations where the inlet of the fan is non-ducted. Inlet bell is flanged and punched to mate up with the standard flanged inlet.

Inlet and Outlet Screen

Inlet and outlet screens are available for added safety on non-ducted applications. Screens are removable for routine inspection and cleaning of the propeller.

Companion Flange

Inlet and outlet companion flanges are available for ease of duct connection. Companion flanges are rolled angle rings punched to match the standard inlet or outlet flange.

Mounting Brackets

Mounted to fan housing. Location varies with discharge orientation and mounting option. See page 4.

Access Door, Bolted

A bolted access door allows for inspection and maintenance of internal fan components.

Shaft Seal

Shaft seal consists of a non-asbestos rubbing ring at the wheel end of the inner cylinder. A shaft seal is recommended when the fan is exposed to wet, corrosive or dirty contaminants. The shaft seal does not make the fan gas tight. (Model BSTAB fans only.)

Spark Resistant Construction - Type B

Type B Spark Resistant Construction is available on belt driven fans with cast aluminum propellers only. (Model BSTAB fans only.)

Vibration Isolators

Rubber-in-shear and spring type isolators are available for floor and ceiling mounted installations.

Special Coatings

Aerovent has an in-house, specialty coating facility offering a wide range of protective coating solutions for fans that are exposed to corrosive atmospheres. Fans are coated with enamel as standard.

Disconnect Switch

A NEMA 1, 3R, 4 or 7/9 safety disconnect switch is available for positive electrical shutoff of the fan and the protection of service personnel. Disconnects are shipped loose for field mounting and wiring.

Metal Nameplate

Available in aluminum or stainless steel.

Engineering Data

Material Specifications

FAN SIZE	HOUSING (GAUGE)	PROPELLERS (GAUGES)	SHAFT SIZE (IN.)	APPROX. SHIP WT. (LB)	
				BSTA	BSTAB
				W/ALUM PROP	W/ALUM PROP
14	14	DIE CAST ALUM.	³ / ₄	33	40
16	14		³ / ₄	53	67
18	14		³ / ₄	60	75
21	14		³ / ₄	85	104
24	14		1	97	118
30	12		1	149	183
36	12		¹ ³ / ₁₆	234	288
42	12		¹ ⁷ / ₁₆	305	375
48	12		¹ ⁷ / ₁₆	547	664
54	12		¹ ⁷ / ₁₆	N/A	803

Mounting Arrangements

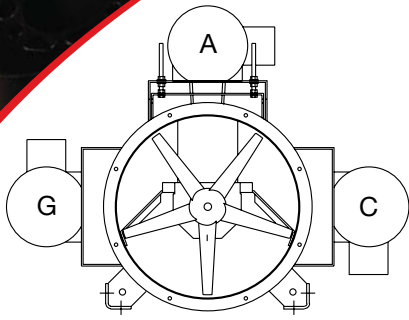

Horizontal Base Mounted (HBM)
(w/mounting brackets)

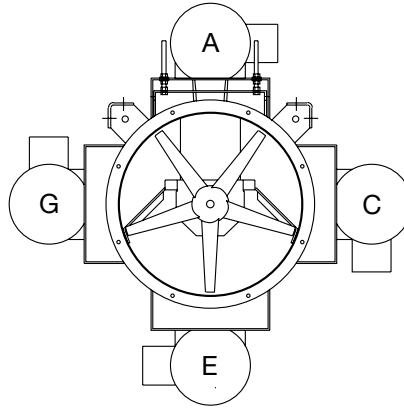

Horizontal Ceiling Hung (HCH)
(w/mounting brackets)

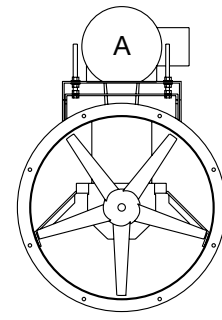

Horizontal (HOR)
(No mounting brackets)

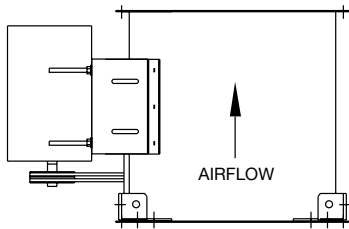

Vertical Up Floor Mounted (VUI)
(w/mounting brackets)

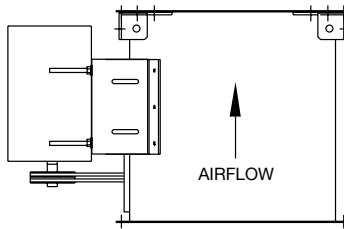

Vertical Up Ceiling Hung (VUO)
(w/mounting brackets)

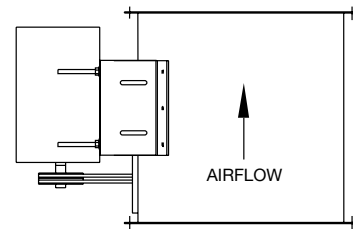

Vertical Up (VUN)
(No mounting brackets)

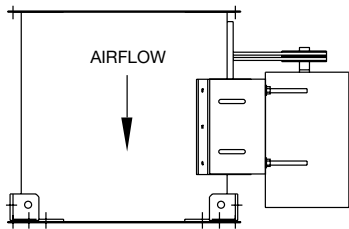

Vertical Down Floor Mounted (VDO)
(w/mounting brackets)

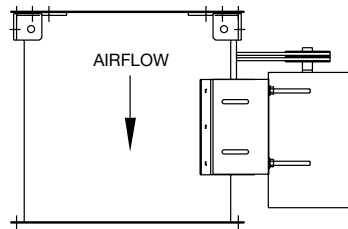

Vertical Down Ceiling Hung (VDI)
(w/mounting brackets)

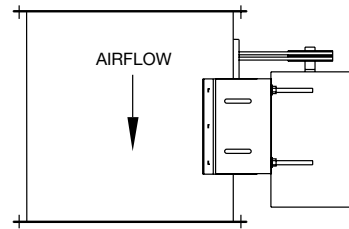

Vertical Down (VDN)
(No mounting brackets)

Model Nomenclature

BSTAB - 24 - B - 1 - 05 - 25

Model _____

BSTA = Direct Drive
BSTAB = Belt Driven

Fan Size _____

Propeller Type _____

B = Backswept

Hub Designation _____

Blade Count _____

Blade Angle _____

Direct Drive

BSTA | Sizes 14 - 18

SIZE	MODEL INFO		MOTOR HP	FAN RPM	LwiA	STATIC PRESSURE (IN. W.G.)										FAN EFF. GRADE					
	NO. OF BLADES	CATALOG NUMBER				0.000	0.125	0.250	0.375	0.500	0.625	0.750	0.875	1.000	1.250		1.500				
14	5	BLADES	Outlet Area: 1.11 ft ²													N/A					
			14B10510	1/4	1160	74	CFM	594	403												
							BHP	0.02	0.02												
			14B10515	1/4	1160	71	CFM	832	654												
							BHP	0.03	0.03												
			14B10520	1/4	1160	70	CFM	1052	860												
							BHP	0.04	0.04												
			14B10525	1/4	1160	68	CFM	1240	1047												
							BHP	0.05	0.05												
			14B10530	1/4	1160	68	CFM	1433	1216												
							BHP	0.06	0.07												
			14B10510	1/4	1750	86	CFM	896	778	645	498										
							BHP	0.07	0.07	0.08	0.07										
			14B10515	1/4	1750	82	CFM	1255	1154	1028	855	612									
BHP	0.10	0.11					0.11	0.12	0.12												
14B10520	1/4	1750	78	CFM	1587	1466	1336	1175													
				BHP	0.12	0.13	0.14	0.15													
14B10525	1/4	1750	78	CFM	1871	1750	1619	1462	1228												
				BHP	0.16	0.17	0.19	0.20	0.21												
14B10530	1/4	1750	78	CFM	2161	2028	1879	1697	1396												
				BHP	0.21	0.23	0.25	0.26	0.26												
16	5	BLADES	Outlet Area: 1.44 ft ²													N/A					
			16B10510	1/4	1160	78	CFM	925	692												
							BHP	0.04	0.04												
			16B10515	1/4	1160	76	CFM	1277	1070	700											
							BHP	0.05	0.06	0.06											
			16B10520	1/4	1160	74	CFM	1607	1374												
							BHP	0.06	0.07												
			16B10525	1/4	1160	71	CFM	1886	1649	1317											
							BHP	0.08	0.09	0.10											
			16B10530	1/4	1160	71	CFM	2176	1911	1503											
							BHP	0.11	0.13	0.13											
			16B10510	1/4	1750	90	CFM	1395	1252	1089	917	724									
							BHP	0.12	0.13	0.13	0.13	0.13									
			16B10515	1/4	1750	85	CFM	1927	1803	1659	1480	1227	922								
BHP	0.17	0.18					0.19	0.20	0.21	0.20											
16B10520	1/4	1750	83	CFM	2424	2276	2118	1946	1721												
				BHP	0.21	0.23	0.25	0.26	0.27												
16B10525	1/3	1750	81	CFM	2846	2695	2534	2363	2143	1861											
				BHP	0.27	0.29	0.32	0.34	0.35	0.36											
16B10530	1/2	1750	81	CFM	3283	3118	2936	2734	2461	2130											
				BHP	0.38	0.40	0.43	0.45	0.46	0.46											
18	5	BLADES	Outlet Area: 1.82 ft ²													N/A					
			18B10510	1/4	1160	82	CFM	1400	1114	755											
							BHP	0.05	0.06	0.06											
			18B10515	1/4	1160	78	CFM	1893	1639	1246											
							BHP	0.08	0.09	0.09											
			18B10520	1/4	1160	77	CFM	2364	2073	1700											
							BHP	0.10	0.11	0.12											
			18B10525	1/4	1160	71	CFM	2757	2455	2097											
							BHP	0.12	0.15	0.16											
			18B10530	1/4	1160	71	CFM	3160	2829	2394											
							BHP	0.17	0.20	0.21											
			18B10510	1/4	1750	93	CFM	2112	1938	1739	1528	1287	1024								
							BHP	0.19	0.20	0.21	0.21	0.21	0.20								
			18B10515	1/3	1750	88	CFM	2856	2701	2525	2319	2062	1705	1315							
BHP	0.26	0.28					0.30	0.31	0.32	0.32	0.31										
18B10520	1/2	1750	87	CFM	3566	3381	3184	2975	2729	2423											
				BHP	0.34	0.37	0.39	0.40	0.42	0.43											
18B10525	3/4	1750	82	CFM	4160	3966	3762	3550	3316	3026	2698										
				BHP	0.42	0.46	0.49	0.52	0.55	0.57	0.58										
18B10530	3/4	1750	82	CFM	4767	4560	4335	4083	3795	3449	3123										
				BHP	0.60	0.64	0.68	0.71	0.73	0.74	0.75										

NOTES:

- Performance certified is for installation Type B: Free inlet, ducted outlet.
- Performance ratings do not include the effects of appurtenances (accessories).
- The sound power level ratings shown are in decibels, referred to 10⁻¹² watts calculated per AMCA Standard 301.
- Values shown are for inlet LwiA sound power levels for installation Type B: Free inlet, ducted outlet. Ratings do not include the effects of end correction.
- Sound power values shown are at the peak cataloged pressure for each RPM.

Direct Drive

BSTA | Sizes 21 - 24

SIZE	MODEL INFO		MOTOR HP	FAN RPM	LwiA	STATIC PRESSURE (IN. W.G.)										FAN EFF. GRADE					
	NO. OF BLADES	CATALOG NUMBER				0.000	0.125	0.250	0.375	0.500	0.625	0.750	0.875	1.000	1.250		1.500				
21	5	BLADES	Outlet Area: 2.46 ft ²													FEG75					
			21B10510	1/4	1160	85	CFM	2376	2018	1582											
							BHP	0.10	0.12	0.12											
			21B10515	1/4	1160	82	CFM	3138	2812	2385	1686										
							BHP	0.14	0.16	0.18	0.18										
			21B10520	1/4	1160	80	CFM	3881	3505	3070											
							BHP	0.20	0.22	0.24											
			21B10525	1/4	1160	75	CFM	4495	4097	3662	3104										
							BHP	0.24	0.28	0.31	0.33										
			21B10530	1/4	1160	74	CFM	5090	4672	4149											
							BHP	0.35	0.39	0.41											
			21B10510	1/2	1750	96	CFM	3584	3361	3117	2849	2563	2231	1852							
BHP	0.36	0.38					0.39	0.41	0.41	0.41	0.40										
21B10515	3/4	1750	92	CFM	4734	4530	4307	4060	3777	3436	2992	2435									
				BHP	0.50	0.53	0.56	0.58	0.61	0.62	0.62	0.60									
21B10520	3/4	1750	90	CFM	5856	5615	5361	5093	4807	4476	4086										
				BHP	0.67	0.71	0.75	0.78	0.80	0.83	0.85										
21B10525	1	1750	84	CFM	6781	6523	6256	5979	5693	5380	5018										
				BHP	0.84	0.90	0.95	1.00	1.05	1.09	1.12										
21B10530	1 1/2	1750	85	CFM	7679	7415	7131	6820	6468	6085	5671										
				BHP	1.19	1.26	1.31	1.36	1.40	1.43	1.45										
24	5	BLADES	Outlet Area: 3.21 ft ²													FEG80					
			24B10510	1/4	860	79	CFM	2791	2164												
							BHP	0.08	0.09												
			24B10515	1/4	860	77	CFM	3611	3013	1950											
							BHP	0.11	0.13	0.13											
			24B10520	1/4	860	77	CFM	4428	3759	2820											
							BHP	0.15	0.17	0.19											
			24B10525	1/4	860	73	CFM	5094	4392	3465											
							BHP	0.19	0.23	0.24											
			24B10530	1/4	860	72	CFM	5687	4945												
							BHP	0.27	0.30												
			24B10510	1/4	1160	89	CFM	3764	3334	2819	2140										
							BHP	0.18	0.21	0.22	0.22										
			24B10515	1/3	1160	84	CFM	4871	4459	3966	3286										
							BHP	0.26	0.29	0.32	0.33										
			24B10520	1/2	1160	83	CFM	5973	5502	4968	4312										
							BHP	0.36	0.40	0.43	0.45										
			24B10525	1/2	1160	79	CFM	6871	6367	5823	5180										
							BHP	0.47	0.52	0.57	0.60										
			24B10530	3/4	1160	80	CFM	7671	7163	6546	5788										
BHP	0.65	0.71					0.75	0.76													
24B10510	3/4	1750	99	CFM	5679	5406	5114	4796	4453	4080	3643	3138									
				BHP	0.64	0.67	0.70	0.73	0.75	0.76	0.75	0.74									
24B10515	1	1750	94	CFM	7348	7086	6807	6506	6179	5813	5382	4857	4190								
				BHP	0.89	0.93	0.98	1.03	1.07	1.10	1.13	1.14	1.11								
24B10520	1 1/2	1750	93	CFM	9011	8709	8391	8056	7701	7319	6895	6419	5899								
				BHP	1.24	1.30	1.36	1.41	1.46	1.49	1.53	1.56	1.56								
24B10525	2	1750	89	CFM	10365	10038	9700	9350	8989	8613	8201	7729	7200								
				BHP	1.62	1.70	1.77	1.84	1.91	1.97	2.02	2.05	2.06								
24B10530	3	1750	90	CFM	11573	11250	10905	10534	10124	9662	9170	8638									
				BHP	2.24	2.33	2.41	2.48	2.54	2.58	2.61	2.62									

NOTES:

- Performance certified is for installation Type B: Free inlet, ducted outlet.
- Performance ratings do not include the effects of appurtenances (accessories).
- The sound power level ratings shown are in decibels, referred to 10⁻¹² watts calculated per AMCA Standard 301.
- Values shown are for inlet LwiA sound power levels for installation Type B: Free inlet, ducted outlet. Ratings do not include the effects of end correction.
- Sound power values shown are at the peak cataloged pressure for each RPM.

Direct Drive

BSTA | Sizes 30 - 36

SIZE	MODEL INFO		MOTOR HP	FAN RPM	LwiA	STATIC PRESSURE (IN. W.G.)										FAN EFF. GRADE					
	NO. OF BLADES	CATALOG NUMBER				0.000	0.125	0.250	0.375	0.500	0.625	0.750	0.875	1.000	1.250		1.500				
30	5	BLADES	Outlet Area: 5.03 ft ²													FEG80					
			30B10510	1/4	860	84	CFM	6162	5308	4133											
							BHP	0.21	0.25	0.26											
			30B10515	1/4	860	80	CFM	7679	6781	5633											
							BHP	0.29	0.34	0.38											
			30B10520	1/3	860	79	CFM	9266	8268	7005											
							BHP	0.43	0.50	0.54											
			30B10525	1/2	860	80	CFM	10531	9444	8148											
							BHP	0.61	0.67	0.71											
			30B10530	3/4	860	82	CFM	11398	10385	8944											
							BHP	0.81	0.87	0.88											
			30B10510	1/2	1160	92	CFM	8311	7705	7033	6230	5117									
							BHP	0.50	0.56	0.61	0.64	0.64									
			30B10515	3/4	1160	87	CFM	10358	9717	9016	8219	7192	5607								
							BHP	0.71	0.78	0.85	0.91	0.95	0.90								
			30B10520	1	1160	87	CFM	12499	11793	11000	10077	9072	7905								
							BHP	1.06	1.16	1.24	1.29	1.33	1.33								
			30B10525	1 1/2	1160	88	CFM	14204	13423	12583	11673	10544	9208								
BHP	1.50	1.59					1.66	1.72	1.73	1.70											
30B10530	2	1160	89	CFM	15375	14666	13850	12829	11568												
				BHP	1.99	2.08	2.15	2.17	2.15												
30B10510	1 1/2	1750	102	CFM	12539	12147	11740	11312	10866	10394	9876	9292	8624	6874							
				BHP	1.73	1.82	1.91	1.99	2.06	2.11	2.16	2.20	2.21	2.14							
30B10515	2	1750	96	CFM	15626	15212	14782	14334	13867	13381	12864	12296	11657	10080							
				BHP	2.45	2.56	2.67	2.77	2.87	2.97	3.06	3.14	3.21	3.24							
30B10520	3	1750	96	CFM	18856	18402	17927	17428	16901	16335	15727	15093	14443	13021							
				BHP	3.65	3.80	3.94	4.07	4.18	4.29	4.37	4.44	4.51	4.59							
30B10525	5	1750	97	CFM	21429	20921	20398	19858	19298	18724	18130	17498	16795	15111							
				BHP	5.15	5.29	5.42	5.55	5.66	5.76	5.84	5.91	5.95	5.92							
36	6	BLADES	Outlet Area: 7.27 ft ²													FEG75					
			36B20610	1/2	860	87	CFM	6985	5998	4858	3404	1577									
							BHP	0.36	0.37	0.36	0.33	0.27									
			36B20615	3/4	860	86	CFM	9587	8528	7277	5749										
							BHP	0.50	0.58	0.59	0.58										
			36B20620	1	860	83	CFM	12189	11091	9795	8223										
							BHP	0.71	0.81	0.86	0.86										
			36B20625	1 1/2	860	81	CFM	14791	13670	12359	10788	8814									
							BHP	0.97	1.08	1.15	1.19	1.16									
			36B20630	1 1/2	860	81	CFM	16828	15589	14095	12388										
							BHP	1.39	1.47	1.52	1.52										
			36B20610	1	1160	93	CFM	9422	8711	7948	7122	6215	5177	3845	2466		1268				
							BHP	0.87	0.90	0.91	0.90	0.89	0.85	0.77	0.68		0.57				
			36B20615	1 1/2	1160	93	CFM	12932	12172	11348	10440	9442	8320	6978	4445						
							BHP	1.24	1.35	1.42	1.45	1.46	1.43	1.37	1.17						
			36B20620	3	1160	91	CFM	16441	15652	14800	13862	12826	11671	10354	8545						
							BHP	1.75	1.89	2.00	2.08	2.12	2.13	2.09	1.98						
			36B20625	5	1160	89	CFM	19951	19144	18276	17329	16280	15126	13830	12334						
							BHP	2.39	2.54	2.67	2.78	2.86	2.91	2.91	2.87						
			36B20630	5	1160	89	CFM	22698	21810	20846	19775	18563	17307	15948	14431						
							BHP	3.41	3.53	3.63	3.70	3.73	3.74	3.72	3.68						
			36B20610	5	1750	106	CFM	14214	13751	13275	12785	12278	11753	11210	10645		10056	8796	7297		
							BHP	3.00	3.04	3.07	3.09	3.11	3.12	3.12	3.10		3.08	3.00	2.85		
			36B20615	7 1/2	1750	104	CFM	19509	19016	18506	17979	17432	16860	16263	15642		14995	13604	12050		
BHP	4.25	4.42					4.58	4.72	4.83	4.91	4.96	5.00	5.01	4.98	4.88						
36B20620	7 1/2	1750	100	CFM	24803	24291	23762	23216	22649	22060	21444	20799	20126	18688	17094						
				BHP	6.01	6.23	6.44	6.63	6.80	6.95	7.06	7.16	7.23	7.31	7.29						
36B20625	10	1750	95	CFM	30098	29573	29033	28475	27899	27302	26680	26028	25347	23897	22310						
				BHP	8.19	8.43	8.65	8.87	9.07	9.25	9.42	9.57	9.70	9.90	10.00						

NOTES:

- Performance certified is for installation Type B: Free inlet, ducted outlet.
- Performance ratings do not include the effects of appurtenances (accessories).
- The sound power level ratings shown are in decibels, referred to 10⁻¹² watts calculated per AMCA Standard 301.
- Values shown are for inlet LwiA sound power levels for installation Type B: Free inlet, ducted outlet. Ratings do not include the effects of end correction.
- Sound power values shown are at the peak cataloged pressure for each RPM.

Direct Drive

BSTA | Sizes 42 - 48

SIZE	MODEL INFO		MOTOR HP	FAN RPM	LwiA	STATIC PRESSURE (IN. W.G.)										FAN EFF. GRADE					
	NO. OF BLADES	CATALOG NUMBER				0.000	0.125	0.250	0.375	0.500	0.625	0.750	0.875	1.000	1.250		1.500				
42	4	BLADES	Outlet Area: 9.85 ft ²													FEG80					
			42B30410	1	860	91	CFM	12260	10914	9282	7011										
							BHP	0.64	0.67	0.69	0.66										
			42B30415	1 1/2	860	88	CFM	15864	14404	12743											
							BHP	0.98	1.04	1.08											
			42B30420	2	860	86	CFM	19509	17937	16234	14286										
							BHP	1.41	1.49	1.55	1.57										
			42B30425	3	860	86	CFM	23084	21442	19720	17833	15549									
							BHP	1.94	2.04	2.12	2.17	2.16									
			42B30430	3	860	86	CFM	25814	24056	22164	19814										
							BHP	2.66	2.72	2.77	2.76										
			42B30410	2	1160	98	CFM	16537	15576	14524	13349	12013	10353	8253							
BHP	1.57	1.62					1.66	1.69	1.68	1.65	1.58										
42B30415	3	1160	96	CFM	21397	20344	19219	18017	16701	15218											
				BHP	2.42	2.49	2.56	2.63	2.66	2.65											
42B30420	5	1160	95	CFM	26315	25171	23974	22729	21405	19978	18335	16326									
				BHP	3.47	3.57	3.66	3.75	3.82	3.85	3.84	3.78									
42B30425	7 1/2	1160	95	CFM	31137	29934	28694	27426	26118	24720	23230	21495	19459								
				BHP	4.77	4.91	5.04	5.14	5.23	5.30	5.33	5.31	5.24								
42B30430	7 1/2	1160	94	CFM	34819	33542	32200	30811	29349	27631	25519										
				BHP	6.53	6.61	6.69	6.75	6.81	6.80	6.71										
48	4	BLADES	Outlet Area: 12.90 ft ²													FEG75					
			48B30410	1 1/2	860	94	CFM	17012	15311	13181	10539										
							BHP	1.09	1.12	1.13	1.09										
			48B30415	2	860	91	CFM	22171	20354	18159											
							BHP	1.67	1.72	1.78											
			48B30420	3	860	90	CFM	27339	25424	23211	20788										
							BHP	2.39	2.47	2.53	2.55										
			48B30425	5	860	88	CFM	32492	30501	28280	25849	23184									
							BHP	3.26	3.36	3.43	3.47	3.48									
			48B30430	5	860	90	CFM	36129	34039	31639	28734										
							BHP	4.50	4.55	4.57	4.53										
			48B30410	3	1160	101	CFM	22946	21748	20389	18815	17171	15249	12871							
BHP	2.67	2.72					2.77	2.79	2.76	2.71	2.62										
48B30415	5	1160	99	CFM	29905	28609	27185	25582	23873	22098											
				BHP	4.09	4.17	4.24	4.32	4.36	4.33											
48B30420	7 1/2	1160	97	CFM	36875	35498	34017	32405	30671	28881	26993	24776									
				BHP	5.87	5.97	6.07	6.16	6.24	6.27	6.25	6.19									
48B30425	10	1160	96	CFM	43826	42385	40859	39234	37512	35709	33856	31874	29561								
				BHP	8.00	8.14	8.27	8.37	8.44	8.49	8.53	8.54	8.48								

NOTES:

- Performance certified is for installation Type B: Free inlet, ducted outlet.
- Performance ratings do not include the effects of appurtenances (accessories).
- The sound power level ratings shown are in decibels, referred to 10⁻¹² watts calculated per AMCA Standard 301.
- Values shown are for inlet LwiA sound power levels for installation Type B: Free inlet, ducted outlet. Ratings do not include the effects of end correction.
- Sound power values shown are at the peak cataloged pressure for each RPM.

Belt Driven

BSTAB | Sizes 14 - 16

SIZE	MODEL INFO		MOTOR HP	FAN RPM	LwiA	STATIC PRESSURE (IN. W.G.)										FAN EFF. GRADE			
	NO. OF BLADES	CATALOG NUMBER				0.000	0.125	0.250	0.375	0.500	0.625	0.750	0.875	1.000	1.250		1.500		
14	5 BLADES	Outlet Area: 1.11 ft ²										N/A							
		14B10520	1/4	2094	82	CFM	1885	1788	1683	1566	1438								
						BHP	0.22	0.24	0.25	0.26	0.27								
		14B10525	1/4	1909	79	CFM	2016	1910	1789	1647	1478								
						BHP	0.22	0.23	0.25	0.26	0.27								
		14B10530	1/4	1762	78	CFM	2132	2003	1847	1648	1380								
						BHP	0.24	0.25	0.26	0.27	0.27								
		14B10520	1/3	2297	84	CFM	2067	1980	1886	1784	1674		1553						
						BHP	0.29	0.31	0.32	0.33	0.34		0.36						
		14B10525	1/3	2094	81	CFM	2211	2116	2010	1889	1751		1587						
						BHP	0.29	0.31	0.32	0.34	0.35		0.36						
		14B10530	1/3	1933	79	CFM	2339	2223	2089	1925	1717								
						BHP	0.31	0.33	0.34	0.36	0.36								
		14B10520	1/2	2638	87	CFM	2374	2299	2220	2135	2045		1950	1848	1736				
BHP	0.45					0.46	0.48	0.49	0.51	0.52	0.53	0.54							
14B10525	1/2	2405	84	CFM	2540	2457	2369	2272	2165	2046	1915	1758							
				BHP	0.44	0.46	0.48	0.49	0.51	0.53	0.54	0.55							
14B10530	1/2	2220	82	CFM	2686	2587	2477	2351	2204	2030	1819								
				BHP	0.47	0.49	0.51	0.53	0.54	0.55	0.55								
14B10520	3/4	3020	91	CFM	2718	2653	2585	2514	2439	2361	2279	2193	2103	1893					
				BHP	0.67	0.69	0.71	0.72	0.74	0.76	0.77	0.78	0.80	0.82					
14B10525	3/4	2753	86	CFM	2907	2836	2760	2680	2594	2501	2401	2293	2174						
				BHP	0.66	0.68	0.70	0.72	0.74	0.76	0.78	0.80	0.81						
14B10530	3/4	2541	85	CFM	3075	2989	2896	2795	2683	2555	2413	2240	2056						
				BHP	0.71	0.73	0.75	0.77	0.79	0.80	0.82	0.82	0.82						
16	5 BLADES	Outlet Area: 1.44 ft ²										N/A							
		16B10520	1/4	1741	83	CFM	2376	2233	2073	1892	1675								
						BHP	0.22	0.24	0.25	0.26	0.27								
		16B10525	1/4	1585	78	CFM	2526	2365	2179	1960	1681								
						BHP	0.22	0.24	0.25	0.27	0.28								
		16B10530	1/4	1458	76	CFM	2655	2456	2206	1879									
						BHP	0.24	0.25	0.27	0.27									
		16B10520	1/3	1910	86	CFM	2607	2478	2336	2179	2006		1796						
						BHP	0.30	0.31	0.33	0.34	0.35		0.36						
		16B10525	1/3	1739	80	CFM	2772	2627	2464	2277	2059								
						BHP	0.29	0.31	0.33	0.34	0.36								
		16B10530	1/3	1600	78	CFM	2914	2735	2523	2259	1944								
						BHP	0.31	0.33	0.35	0.36	0.36								
		16B10520	1/2	2194	88	CFM	2995	2884	2765	2636	2497		2348	2179					
BHP	0.45					0.47	0.49	0.50	0.52	0.53	0.54								
16B10525	1/2	1997	83	CFM	3183	3058	2923	2773	2607	2422	2200								
				BHP	0.43	0.46	0.48	0.50	0.52	0.54	0.55								
16B10530	1/2	1837	81	CFM	3345	3192	3021	2819	2581	2306									
				BHP	0.47	0.49	0.52	0.53	0.54	0.55									
16B10520	3/4	2511	90	CFM	3428	3331	3230	3122	3009	2888	2760	2625	2471						
				BHP	0.67	0.69	0.72	0.74	0.75	0.77	0.79	0.80	0.82						
16B10525	3/4	2286	86	CFM	3644	3536	3421	3298	3165	3021	2865	2689	2491						
				BHP	0.65	0.68	0.71	0.73	0.76	0.78	0.80	0.82	0.83						
16B10530	3/4	2103	84	CFM	3830	3698	3554	3396	3214	3009	2767	2532							
				BHP	0.71	0.73	0.76	0.78	0.80	0.81	0.82	0.82							

NOTES:

1. Performance certified is for installation Type B: Free inlet, ducted outlet.
2. Power rating (BHP) does not include transmission losses).
3. Performance ratings do not include the effects of appurtenances (accessories).
4. The sound power level ratings shown are in decibels, referred to 10⁻¹² watts calculated per AMCA Standard 301.
5. Values shown are for inlet LwiA sound power levels for installation Type B: Free inlet, ducted outlet. Ratings do not include the effects of end correction.
6. Sound power values shown are at the peak cataloged pressure for each RPM.

Belt Driven

BSTAB | Size 18

SIZE	MODEL INFO		MOTOR HP	FAN RPM	Lw _{iA}	STATIC PRESSURE (IN. W.G.)										FAN EFF. GRADE										
	NO. OF BLADES	CATALOG NUMBER				0.000	0.125	0.250	0.375	0.500	0.625	0.750	0.875	1.000	1.250		1.500									
18	5	BLADES				Outlet Area: 1.82 ft ²										N/A										
						18B10520	1/4	1494	82	CFM	2976	2764	2521	2242												
										BHP	0.23	0.24	0.26	0.27												
						18B10525	1/4	1355	75	CFM	3127	2883	2601	2266												
										BHP	0.21	0.24	0.26	0.27												
						18B10530	1/4	1244	74	CFM	3257	2954	2576	2158												
										BHP	0.23	0.26	0.27	0.28												
						18B10520	1/3	1639	84	CFM	3265	3074	2860	2619	2342											
										BHP	0.30	0.32	0.33	0.35	0.36											
						18B10525	1/3	1486	78	CFM	3430	3209	2962	2682	2347											
										BHP	0.28	0.31	0.33	0.35	0.36											
						18B10530	1/3	1365	75	CFM	3574	3302	2977	2593												
										BHP	0.31	0.33	0.35	0.36												
						18B10520	1/2	1883	89	CFM	3751	3587	3409	3214	3001		2767	2483								
										BHP	0.45	0.47	0.50	0.51	0.53		0.54	0.55								
						18B10525	1/2	1707	81	CFM	3940	3750	3545	3318	3070		2782									
										BHP	0.43	0.46	0.49	0.51	0.53		0.55									
						18B10530	1/2	1567	79	CFM	4102	3870	3608	3301	2962											
										BHP	0.47	0.50	0.52	0.54	0.55											
						18B10520	3/4	2155	90	CFM	4293	4150	4000	3839	3665		3480	3284	3059							
				BHP	0.68	0.70	0.73	0.75	0.77	0.79	0.81	0.82														
18B10525	3/4	1954	84	CFM	4510	4346	4172	3985	3784	3568	3331	3063														
				BHP	0.64	0.68	0.71	0.74	0.77	0.80	0.82	0.83														
18B10530	3/4	1794	82	CFM	4697	4496	4278	4034	3760	3461	3185															
				BHP	0.70	0.74	0.77	0.79	0.81	0.82	0.83															

NOTES:

1. Performance certified is for installation Type B: Free inlet, ducted outlet.
2. Power rating (BHP) does not include transmission losses).
3. Performance ratings do not include the effects of appurtenances (accessories).
4. The sound power level ratings shown are in decibels, referred to 10⁻¹² watts calculated per AMCA Standard 301.
5. Values shown are for inlet Lw_{iA} sound power levels for installation Type B: Free inlet, ducted outlet. Ratings do not include the effects of end correction.
6. Sound power values shown are at the peak cataloged pressure for each RPM.

Belt Driven

BSTAB | Size 21

SIZE	MODEL INFO		MOTOR HP	FAN RPM	LwiA	STATIC PRESSURE (IN. W.G.)										FAN EFF. GRADE					
	NO. OF BLADES	CATALOG NUMBER				0.000	0.125	0.250	0.375	0.500	0.625	0.750	0.875	1.000	1.250		1.500				
21	5 BLADES	Outlet Area: 2.46 ft ²													FEG71						
		21B10520	1/4	1197	80	CFM	3877	3525	3104												
						BHP	0.23	0.25	0.27												
		21B10525	1/4	1086	72	CFM	4038	3630	3150												
						BHP	0.22	0.25	0.27												
		21B10530	1/4	1000	70	CFM	4173	3667													
						BHP	0.24	0.27													
		21B10520	1/3	1313	82	CFM	4253	3937	3570	3148											
						BHP	0.30	0.33	0.35	0.36											
		21B10525	1/3	1192	74	CFM	4432	4066	3645												
						BHP	0.29	0.32	0.35												
		21B10530	1/3	1097	73	CFM	4578	4125	3581												
						BHP	0.32	0.35	0.36												
		21B10520	1/2	1507	86	CFM	4881	4610	4309	3969	3593										
						BHP	0.46	0.48	0.51	0.53	0.55										
		21B10525	1/2	1369	77	CFM	5090	4776	4429	4043											
						BHP	0.44	0.48	0.51	0.54											
		21B10530	1/2	1260	77	CFM	5258	4871	4428	3927											
						BHP	0.48	0.52	0.54	0.55											
		21B10520	3/4	1725	89	CFM	5587	5353	5101	4825	4522	4198	3819								
						BHP	0.69	0.72	0.75	0.77	0.79	0.81	0.82								
		21B10525	3/4	1567	82	CFM	5826	5555	5263	4946	4603	4219									
						BHP	0.66	0.70	0.74	0.78	0.81	0.83									
		21B10530	3/4	1442	79	CFM	6017	5684	5319	4905											
						BHP	0.72	0.76	0.79	0.81											
		21B10520	1	1899	91	CFM	6151	5940	5715	5475	5214	4934	4641	4302							
						BHP	0.91	0.95	0.98	1.01	1.04	1.06	1.09	1.10							
		21B10525	1	1724	84	CFM	6410	6165	5905	5627	5329	5013	4661								
				BHP	0.88	0.93	0.97	1.01	1.05	1.08	1.10										
21B10530	1	1587	81	CFM	6623	6322	5999	5643	5255												
				BHP	0.97	1.01	1.04	1.07	1.09												
21B10520	1 1/2	2174	93	CFM	7042	6858	6667	6465	6252	6026	5786	5536	5275								
				BHP	1.37	1.41	1.45	1.49	1.52	1.55	1.58	1.61	1.63								
21B10525	1 1/2	1974	87	CFM	7339	7127	6905	6672	6426	6167	5895	5612	5294								
				BHP	1.32	1.37	1.43	1.48	1.52	1.56	1.60	1.63	1.65								
21B10530	1 1/2	1817	85	CFM	7582	7322	7047	6756	6438	6099	5749										
				BHP	1.45	1.50	1.54	1.58	1.61	1.63	1.65										
21B10520	2	2393	95	CFM	7751	7585	7413	7234	7047	6852	6645	6429	6204	5728							
				BHP	1.83	1.88	1.92	1.96	2.00	2.04	2.07	2.10	2.13	2.19							
21B10525	2	2172	88	CFM	8075	7883	7683	7476	7261	7035	6799	6553	6299								
				BHP	1.75	1.82	1.88	1.93	1.99	2.04	2.08	2.12	2.16								
21B10530	2	1999	87	CFM	8342	8106	7860	7602	7330	7035	6726	6410									
				BHP	1.93	1.99	2.04	2.08	2.12	2.15	2.17	2.19									

NOTES:

1. Performance certified is for installation Type B: Free inlet, ducted outlet.
2. Power rating (BHP) does not include transmission losses.
3. Performance ratings do not include the effects of appurtenances (accessories).
4. The sound power level ratings shown are in decibels, referred to 10⁻¹² watts calculated per AMCA Standard 301.
5. Values shown are for inlet LwiA sound power levels for installation Type B: Free inlet, ducted outlet. Ratings do not include the effects of end correction.
6. Sound power values shown are at the peak cataloged pressure for each RPM.

Belt Driven

BSTAB | Size 24

SIZE	MODEL INFO		MOTOR HP	FAN RPM	LwiA	STATIC PRESSURE (IN. W.G.)										FAN EFF. GRADE											
	NO. OF BLADES	CATALOG NUMBER				0.000	0.125	0.250	0.375	0.500	0.625	0.750	0.875	1.000	1.250		1.500										
24	5	BLADES				Outlet Area: 3.21 ft ²										FEG71											
						24B10520	1/3	1074	80	CFM	5304	4804	4203														
										BHP	0.31	0.33	0.35														
						24B10525	1/3	979	74	CFM	5510	4930	4235														
										BHP	0.31	0.34	0.36														
						24B10530	1/3	903	72	CFM	5629	4923															
										BHP	0.33	0.36															
						24B10520	1/2	1233	83	CFM	6090	5662	5173	4619													
										BHP	0.46	0.50	0.52	0.54													
						24B10525	1/2	1124	78	CFM	6326	5831	5264	4602													
										BHP	0.46	0.50	0.53	0.55													
						24B10530	1/2	1037	76	CFM	6465	5866	5149														
										BHP	0.50	0.53	0.55														
						24B10520	3/4	1412	87	CFM	6974	6606	6201	5747	5256		4674										
										BHP	0.69	0.73	0.77	0.80	0.82		0.83										
						24B10525	3/4	1287	81	CFM	7243	6817	6348	5823	5227												
										BHP	0.70	0.74	0.78	0.81	0.83												
						24B10530	3/4	1187	80	CFM	7400	6886	6301	5634													
										BHP	0.75	0.79	0.82	0.82													
						24B10520	1	1554	90	CFM	7675	7343	6986	6594	6165		5710	5177									
										BHP	0.93	0.97	1.01	1.04	1.07		1.10	1.10									
						24B10525	1	1417	84	CFM	7975	7591	7177	6722	6228		5668										
										BHP	0.93	0.98	1.03	1.06	1.09		1.10										
						24B10530	1	1307	81	CFM	8148	7685	7178	6596													
										BHP	1.01	1.05	1.08	1.10													
						24B10520	1 1/2	1778	93	CFM	8782	8494	8190	7867	7518		7144	6756	6328	5848							
										BHP	1.39	1.44	1.49	1.53	1.56		1.60	1.63	1.65	1.65							
						24B10525	1 1/2	1621	86	CFM	9123	8790	8439	8063	7658		7228	6761									
				BHP	1.39	1.45	1.51	1.56	1.60	1.63	1.65																
24B10530	1 1/2	1496	85	CFM	9326	8926	8498	8031	7514	6977																	
				BHP	1.51	1.56	1.60	1.63	1.64	1.65																	
24B10520	2	1957	93	CFM	9666	9405	9133	8848	8546	8223	7883	7532	7162														
				BHP	1.85	1.91	1.96	2.01	2.05	2.09	2.13	2.16	2.19														
24B10525	2	1785	89	CFM	10046	9745	9431	9100	8749	8376	7985	7570	7109														
				BHP	1.86	1.92	1.99	2.05	2.10	2.14	2.17	2.20	2.20														
24B10530	2	1646	87	CFM	10261	9900	9518	9113	8666	8192	7701																
				BHP	2.01	2.06	2.11	2.15	2.18	2.19	2.20																
24B10520	3	2240	97	CFM	11063	10837	10603	10361	10109	9847	9571	9281	8981	8360	7645												
				BHP	2.77	2.84	2.90	2.96	3.02	3.07	3.11	3.16	3.19	3.27	3.30												
24B10525	3	2043	92	CFM	11498	11237	10967	10686	10395	10090	9769	9435	9090	8329													
				BHP	2.78	2.86	2.94	3.01	3.07	3.13	3.18	3.22	3.26	3.30													
24B10530	3	1884	90	CFM	11745	11431	11104	10763	10405	10017	9605	9184															
				BHP	3.01	3.07	3.13	3.18	3.23	3.26	3.28	3.29															

NOTES:

- Performance certified is for installation Type B: Free inlet, ducted outlet.
- Power rating (BHP) does not include transmission losses.
- Performance ratings do not include the effects of appurtenances (accessories).
- The sound power level ratings shown are in decibels, referred to 10⁻¹² watts calculated per AMCA Standard 301.
- Values shown are for inlet LwiA sound power levels for installation Type B: Free inlet, ducted outlet. Ratings do not include the effects of end correction.
- Sound power values shown are at the peak cataloged pressure for each RPM.

Belt Driven

BSTAB | Size 30

SIZE	MODEL INFO		MOTOR HP	FAN RPM	LwiA	STATIC PRESSURE (IN. W.G.)											FAN EFF. GRADE			
	NO. OF BLADES	CATALOG NUMBER				0.000	0.125	0.250	0.375	0.500	0.625	0.750	0.875	1.000	1.250	1.500				
30	5 BLADES	Outlet Area: 5.03 ft ²														FEG71				
		30B10520	1/2	863	78	CFM	8774	7789	6617											
						BHP	0.47	0.52	0.55											
		30B10525	1/2	793	78	CFM	9047	7903	6404											
						BHP	0.51	0.55	0.54											
		30B10530	1/2	735	76	CFM	9060	7722												
						BHP	0.53	0.55												
		30B10520	3/4	988	82	CFM	10045	9201	8227	7132										
						BHP	0.71	0.77	0.81	0.83										
		30B10525	3/4	907	79	CFM	10347	9377	8189											
						BHP	0.77	0.81	0.83											
		30B10530	3/4	842	80	CFM	10378	9260	7846											
						BHP	0.80	0.83	0.82											
		30B10520	1	1088	85	CFM	11062	10304	9456	8517	7439									
						BHP	0.95	1.01	1.06	1.10	1.10									
		30B10525	1	999	83	CFM	11397	10529	9507	8294										
						BHP	1.02	1.07	1.10	1.09										
		30B10530	1	926	82	CFM	11414	10414	9176											
						BHP	1.07	1.10	1.09											
		30B10520	1 1/2	1245	88	CFM	12658	12003	11297	10512	9686	8759								
						BHP	1.42	1.49	1.56	1.60	1.64	1.65								
		30B10525	1 1/2	1143	86	CFM	13039	12293	11461	10498	9408									
						BHP	1.53	1.59	1.64	1.65	1.64									
		30B10530	1 1/2	1060	86	CFM	13066	12208	11227	10052										
						BHP	1.60	1.64	1.65	1.63										
		30B10520	2	1370	90	CFM	13929	13337	12709	12030	11292	10537	9687							
						BHP	1.89	1.98	2.05	2.11	2.15	2.20	2.20							
		30B10525	2	1258	89	CFM	14351	13679	12948	12123	11215	10194								
				BHP	2.04	2.11	2.16	2.19	2.20	2.18										
30B10530	2	1167	87	CFM	14384	13613	12764	11756												
				BHP	2.14	2.18	2.20	2.19												
30B10520	3	1568	93	CFM	15942	15429	14892	14328	13725	13081	12427	11734	10976							
				BHP	2.84	2.93	3.02	3.10	3.17	3.22	3.27	3.30	3.29							
30B10525	3	1440	91	CFM	16428	15846	15227	14562	13824	13035	12164									
				BHP	3.06	3.14	3.21	3.26	3.29	3.30	3.29									
30B10530	3	1336	91	CFM	16468	15801	15086	14304	13395	12478										
				BHP	3.21	3.26	3.29	3.31	3.28	3.26										
30B10520	5	1859	97	CFM	18900	18470	18027	17568	17092	16596	16070	15524	14971	13810	12464					
				BHP	4.73	4.84	4.95	5.05	5.15	5.23	5.30	5.36	5.42	5.50	5.44					
30B10525	5	1707	95	CFM	19473	18987	18480	17948	17388	16784	16139	15469	14754							
				BHP	5.10	5.20	5.29	5.36	5.43	5.47	5.49	5.50	5.49							
30B10530	5	1583	95	CFM	19512	18955	18370	17754	17098	16353	15559	14798								
				BHP	5.34	5.40	5.45	5.48	5.50	5.48	5.44	5.42								

NOTES:

- Performance certified is for installation Type B: Free inlet, ducted outlet.
- Power rating (BHP) does not include transmission losses.
- Performance ratings do not include the effects of appurtenances (accessories).
- The sound power level ratings shown are in decibels, referred to 10⁻¹² watts calculated per AMCA Standard 301.
- Values shown are for inlet LwiA sound power levels for installation Type B: Free inlet, ducted outlet. Ratings do not include the effects of end correction.
- Sound power values shown are at the peak cataloged pressure for each RPM.

Belt Driven

BSTAB | Size 36

SIZE	MODEL INFO		MOTOR HP	FAN RPM	LwiA	STATIC PRESSURE (IN. W.G.)										FAN EFF. GRADE			
	NO. OF BLADES	CATALOG NUMBER				0.000	0.125	0.250	0.375	0.500	0.625	0.750	0.875	1.000	1.250		1.500		
36	6	BLADES				Outlet Area: 7.27 ft ²										FEG71			
						CFM	11453	10363	9079	7554									
						BHP	0.72	0.79	0.82	0.81									
						CFM	12385	11122	9600	7671									
						BHP	0.72	0.79	0.82	0.81									
						CFM	12827	11263	9400										
						BHP	0.79	0.82	0.82										
						CFM	12610	11634	10515	9265	7732								
						BHP	0.96	1.04	1.09	1.10	1.07								
						CFM	13630	12500	11175	9634									
						BHP	0.96	1.04	1.09	1.10									
						CFM	14117	12718	11094										
						BHP	1.06	1.09	1.10										
						CFM	14427	13585	12659	11624	10510	9179							
						BHP	1.44	1.54	1.61	1.64	1.65	1.62							
						CFM	15602	14631	13546	12315	10921	9250							
						BHP	1.44	1.54	1.60	1.64	1.64	1.60							
						CFM	16170	14967	13617	12145									
						BHP	1.59	1.63	1.65	1.65									
						CFM	15880	15122	14304	13405	12438	11396	10179	8344					
						BHP	1.92	2.03	2.11	2.17	2.19	2.20	2.16	2.01					
						CFM	17170	16296	15343	14274	13127	11795	10278						
						BHP	1.93	2.03	2.11	2.16	2.20	2.19	2.13						
						CFM	17786	16703	15521	14208	12805								
						BHP	2.11	2.17	2.20	2.20	2.19								
						CFM	18182	17525	16830	16091	15292	14449	13578	12593	11502				
						BHP	2.88	3.01	3.12	3.20	3.25	3.28	3.30	3.28	3.23				
						CFM	19660	18903	18098	17231	16279	15281	14190	12926	11551				
BHP	2.89	3.01	3.11	3.20	3.25	3.29	3.30	3.26	3.19										
CFM	20366	19429	18432	17350	16192	14981	13570												
BHP	3.17	3.23	3.28	3.31	3.31	3.29	3.26												
CFM	21560	21010	20439	19843	19221	18562	17869	17155	16430	14793	12930								
BHP	4.81	4.96	5.10	5.22	5.32	5.39	5.44	5.48	5.50	5.47	5.33								
CFM	23314	22681	22021	21329	20600	19817	18991	18147	17257	15152									
BHP	4.82	4.97	5.10	5.21	5.31	5.39	5.44	5.49	5.51	5.43									
CFM	24145	23361	22543	21688	20776	19806	18833	17791	16663										
BHP	5.28	5.36	5.43	5.48	5.51	5.51	5.51	5.49	5.46										
CFM	24669	24190	23698	23190	22666	22124	21558	20967	20356	19102	17750								
BHP	7.20	7.38	7.54	7.69	7.83	7.95	8.04	8.11	8.16	8.23	8.24								
CFM	26677	26127	25559	24971	24361	23726	23056	22352	21624	20129	18391								
BHP	7.22	7.39	7.55	7.69	7.82	7.94	8.03	8.10	8.16	8.25	8.21								
CFM	27634	26951	26248	25520	24767	23974	23137	22280	21434	19558									
BHP	7.91	8.01	8.09	8.16	8.22	8.25	8.26	8.26	8.26	8.26	8.20								

NOTES:

- Performance certified is for installation Type B: Free inlet, ducted outlet.
- Power rating (BHP) does not include transmission losses).
- Performance ratings do not include the effects of appurtenances (accessories).
- The sound power level ratings shown are in decibels, referred to 10⁻¹² watts calculated per AMCA Standard 301.
- Values shown are for inlet LwiA sound power levels for installation Type B: Free inlet, ducted outlet. Ratings do not include the effects of end correction.
- Sound power values shown are at the peak cataloged pressure for each RPM.

Belt Driven

BSTAB | Size 42

SIZE	MODEL INFO		MOTOR HP	FAN RPM	LwiA	STATIC PRESSURE (IN. W.G.)											FAN EFF. GRADE				
	NO. OF BLADES	CATALOG NUMBER				0.000	0.125	0.250	0.375	0.500	0.625	0.750	0.875	1.000	1.250	1.500					
42	4	BLADES	Outlet Area: 9.85 ft ²													FEG71					
			42B30420	1	768	83	CFM	16400	14705	12792											
							BHP	1.02	1.07	1.10											
			42B30425	1	690	78	CFM	17240	15301	13121											
							BHP	1.03	1.08	1.10											
			42B30430	1	636	77	CFM	17571	15148												
							BHP	1.08	1.10												
			42B30420	1½	880	86	CFM	18792	17337	15724	13963										
							BHP	1.54	1.60	1.64	1.65										
			42B30425	1½	789	82	CFM	19714	18045	16203	14092										
							BHP	1.54	1.60	1.64	1.64										
			42B30430	1½	728	81	CFM	20112	18088	15511											
							BHP	1.62	1.65	1.62											
			42B30420	2	968	89	CFM	20671	19360	17931	16398	14635									
							BHP	2.05	2.12	2.17	2.20	2.19									
			42B30425	2	869	85	CFM	21713	20211	18578	16849	14663									
							BHP	2.06	2.13	2.18	2.20	2.18									
			42B30430	2	802	83	CFM	22157	20361	18146											
							BHP	2.17	2.21	2.19											
			42B30420	3	1108	92	CFM	23660	22527	21317	20025	18675	17169								
							BHP	3.07	3.15	3.22	3.27	3.30	3.29								
			42B30425	3	995	88	CFM	24861	23563	22178	20707	19185	17314								
							BHP	3.09	3.17	3.24	3.28	3.31	3.28								
			42B30430	3	918	87	CFM	25362	23827	22030	19978										
							BHP	3.26	3.30	3.30	3.27										
			42B30420	5	1314	96	CFM	28059	27112	26122	25082	23992	22864	21718	20407		18878				
							BHP	5.12	5.22	5.31	5.38	5.44	5.48	5.51	5.50		5.44				
			42B30425	5	1179	92	CFM	29458	28372	27237	26046	24805	23530	22177	20550						
				BHP	5.14	5.24	5.33	5.40	5.45	5.49	5.50	5.46									
42B30430	5	1088	91	CFM	30058	28789	27387	25790	24063												
				BHP	5.42	5.48	5.51	5.50	5.46												
42B30420	7½	1504	100	CFM	32116	31293	30442	29560	28644	27694	26717	25719	24716	22282							
				BHP	7.68	7.80	7.90	7.99	8.07	8.14	8.19	8.23	8.26	8.20							
42B30425	7½	1350	97	CFM	33731	32787	31812	30801	29753	28671	27563	26448	25209	22168							
				BHP	7.72	7.84	7.94	8.04	8.11	8.17	8.21	8.25	8.26	8.12							
42B30430	7½	1245	94	CFM	34396	33299	32119	30831	29405	27896											
				BHP	8.13	8.19	8.24	8.25	8.23	8.19											
42B30420	10	1655	102	CFM	35341	34595	33828	33039	32226	31386	30522	29637	28735	26898	24653						
				BHP	10.24	10.36	10.48	10.59	10.68	10.77	10.84	10.90	10.95	11.01	10.93						
42B30425	10	1485	99	CFM	37104	36249	35370	34465	33533	32573	31588	30583	29569	27327	24553						
				BHP	10.27	10.41	10.53	10.63	10.73	10.80	10.87	10.92	10.97	10.98	10.82						
42B30430	10	1371	97	CFM	37877	36886	35837	34716	33498	32179	30806	29363									
				BHP	10.85	10.93	10.98	11.02	11.02	10.99	10.94	10.86									

NOTES:

- Performance certified is for installation Type B: Free inlet, ducted outlet.
- Power rating (BHP) does not include transmission losses.
- Performance ratings do not include the effects of appurtenances (accessories).
- The sound power level ratings shown are in decibels, referred to 10⁻¹² watts calculated per AMCA Standard 301.
- Values shown are for inlet LwiA sound power levels for installation Type B: Free inlet, ducted outlet. Ratings do not include the effects of end correction.
- Sound power values shown are at the peak cataloged pressure for each RPM.

Belt Driven

BSTAB | Size 48

SIZE	MODEL INFO		MOTOR HP	FAN RPM	LwiA	STATIC PRESSURE (IN. W.G.)										FAN EFF. GRADE				
	NO. OF BLADES	CATALOG NUMBER				0.000	0.125	0.250	0.375	0.500	0.625	0.750	0.875	1.000	1.250		1.500			
48	4	BLADES				Outlet Area: 12.90 ft ²										FEG67				
						CFM	22327	20116	17627											
						BHP	1.59	1.63	1.65											
						CFM	23652	21113	18306											
						BHP	1.59	1.63	1.65											
						CFM	23807	20591												
						BHP	1.65	1.64												
						CFM	24587	22603	20387	17968										
						BHP	2.12	2.17	2.20	2.20										
						CFM	26027	23746	21236	18319										
						BHP	2.12	2.17	2.20	2.18										
						CFM	26191	23367												
						BHP	2.20	2.20												
						CFM	28125	26412	24546	22550	20368									
						BHP	3.17	3.24	3.28	3.30	3.28									
						CFM	29800	27831	25703	23469										
						BHP	3.19	3.25	3.28	3.30										
						CFM	29960	27573												
						BHP	3.29	3.30												
						CFM	33357	31930	30418	28804	27119	25410	23338							
BHP	5.29	5.37	5.44	5.48	5.50	5.51	5.45													
CFM	35320	33676	31942	30109	28220	26152														
BHP	5.31	5.38	5.43	5.47	5.50	5.49														
CFM	35537	33579	31315																	
BHP	5.50	5.51	5.48																	
CFM	38173	36935	35642	34285	32860	31388	29911	28314												
BHP	7.93	8.02	8.11	8.17	8.22	8.24	8.26	8.23												
CFM	40421	38993	37508	35956	34340	32687	31002	28975												
BHP	7.96	8.04	8.11	8.16	8.20	8.23	8.25	8.20												
CFM	40652	38966	37103	34971																
BHP	8.23	8.25	8.24	8.17																

NOTES:

1. Performance certified is for installation Type B: Free inlet, ducted outlet.
2. Power rating (BHP) does not include transmission losses.
3. Performance ratings do not include the effects of appurtenances (accessories).
4. The sound power level ratings shown are in decibels, referred to 10⁻¹² watts calculated per AMCA Standard 301.
5. Values shown are for inlet LwiA sound power levels for installation Type B: Free inlet, ducted outlet. Ratings do not include the effects of end correction.
6. Sound power values shown are at the peak cataloged pressure for each RPM.

Belt Driven

BSTAB | Size 54

SIZE	MODEL INFO		MOTOR HP	FAN RPM	LwiA	STATIC PRESSURE (IN. W.G.)										FAN EFF. GRADE						
	NO. OF BLADES	CATALOG NUMBER				0.000	0.125	0.250	0.375	0.500	0.625	0.750	0.875	1.000	1.250		1.500					
54	6	BLADES	Outlet Area: 16.28 ft ²													FEG75						
			54B40620	1 1/2	571	88	CFM	26230	23584	20469												
							BHP	1.46	1.57	1.64												
			54B40625	1 1/2	518	83	CFM	27880	24679	20929												
							BHP	1.53	1.62	1.66												
			54B40630	1 1/2	473	82	CFM	28364	24550													
							BHP	1.61	1.66													
			54B40620	2	628	90	CFM	28848	26479	23747												
							BHP	1.94	2.07	2.16												
			54B40625	2	570	84	CFM	30679	27821	24497												
							BHP	2.04	2.15	2.19												
			54B40630	2	520	84	CFM	31183	27794													
							BHP	2.14	2.20													
			54B40620	3	719	93	CFM	33029	30993	28725	26218											
							BHP	2.91	3.06	3.18	3.26											
			54B40625	3	652	88	CFM	35093	32640	29868	26864											
							BHP	3.05	3.18	3.26	3.30											
			54B40630	3	595	88	CFM	35680	32790	29407												
							BHP	3.21	3.28	3.30												
			54B40620	5	852	98	CFM	39138	37445	35624	33647	31531	29320									
							BHP	4.83	5.02	5.19	5.31	5.41	5.50									
			54B40625	5	773	92	CFM	41605	39570	37359	34941	32402										
							BHP	5.08	5.25	5.37	5.44	5.49										
			54B40630	5	706	92	CFM	42337	39950	37297	34335											
							BHP	5.36	5.45	5.50	5.51											
			54B40620	7 1/2	975	101	CFM	44789	43321	41772	40128	38377	36533	34628	32595							
							BHP	7.24	7.46	7.66	7.83	7.97	8.09	8.19	8.26							
			54B40625	7 1/2	885	96	CFM	47633	45872	44001	41996	39855	37636	35374								
							BHP	7.62	7.82	7.98	8.10	8.17	8.22	8.27								
			54B40630	7 1/2	808	96	CFM	48453	46391	44169	41728	39108										
BHP	8.03	8.14					8.22	8.26	8.26													
54B40620	10	1073	104	CFM	49290	47962	46576	45122	43590	41979	40300	38573	36797									
				BHP	9.66	9.90	10.12	10.33	10.50	10.65	10.77	10.88	10.98									
54B40625	10	974	99	CFM	52424	50831	49159	47394	45520	43554	41535	39502										
				BHP	10.16	10.38	10.57	10.72	10.83	10.90	10.96	11.01										
54B40630	10	889	98	CFM	53311	51448	49470	47347	45047	42649												
				BHP	10.69	10.82	10.92	10.98	11.00	11.01												
54B40620	15	1229	107	CFM	56457	55303	54112	52878	51598	50266	48880	47444	45967	42932								
				BHP	14.51	14.79	15.06	15.30	15.53	15.73	15.91	16.07	16.21	16.45								
54B40625	15	1115	103	CFM	60013	58629	57195	55703	54146	52515	50818	49074	47305	43623								
				BHP	15.24	15.50	15.73	15.93	16.10	16.22	16.31	16.38	16.45	16.53								
54B40630	15	1018	102	CFM	61046	59431	57742	55968	54088	52088	50007											
				BHP	16.06	16.21	16.33	16.43	16.49	16.52	16.53											

NOTES:

1. Performance certified is for installation Type B: Free inlet, ducted outlet.
2. Power rating (BHP) does not include transmission losses.
3. Performance ratings do not include the effects of appurtenances (accessories).
4. The sound power level ratings shown are in decibels, referred to 10⁻¹² watts calculated per AMCA Standard 301.
5. Values shown are for inlet LwiA sound power levels for installation Type B: Free inlet, ducted outlet. Ratings do not include the effects of end correction.
6. Sound power values shown are at the peak cataloged pressure for each RPM.



©2013 Aerovent

"Catalog illustrations cover the general appearance of Aerovent products at the time of publication and we reserve the right to make changes in design and construction at any time without notice."

BSTA/BSTAB

Direct Drive - BSTA

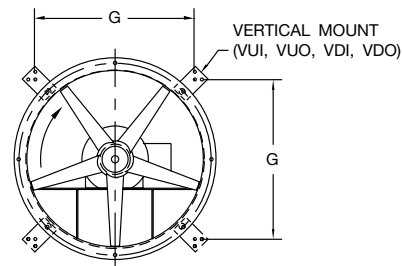
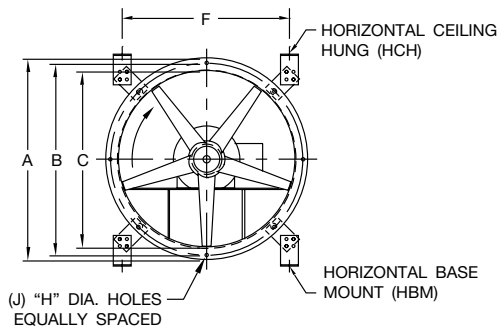
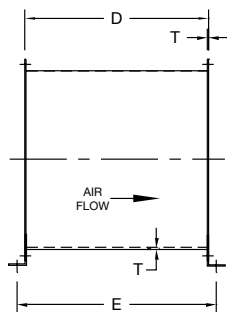

FAN SIZE	A	B	C	D	E	F	G	H	J	T	MAX. HP	MAX FRAME
14	16.88	15.88	14.25	19.00	21.88	16.00	14.81	0.56	8	14 GA.	3/4	56
16	19.63	17.88	16.13	19.00	21.88	17.88	16.68	0.56	8	14 GA.	1	143T
18	21.75	19.88	18.25	19.00	21.88	19.50	18.25	0.56	8	14 GA.	1 1/2	145T
21	24.75	22.88	21.25	20.69	23.56	21.50	20.25	0.56	8	14 GA.	2	145T
24	27.75	25.88	24.25	20.69	23.56	23.63	22.44	0.56	8	14 GA.	3	184T
30	33.88	32.00	30.38	26.00	28.88	28.00	26.75	0.56	8	12 GA.	5	184T
36	40.50	38.38	36.50	27.00	29.88	32.38	31.13	0.56	16	12 GA.	1 1/2	215T
42	46.75	44.63	42.75	31.00	33.88	34.63	33.44	0.69	16	12 GA.	10	215T
48	52.63	50.63	48.63	35.00	37.88	41.00	39.75	0.69	16	12 GA.	10	254T

Dimensions shown are in inches unless otherwise indicated.
 Dimensions are not to be used for construction.

Belt Driven - BSTAB

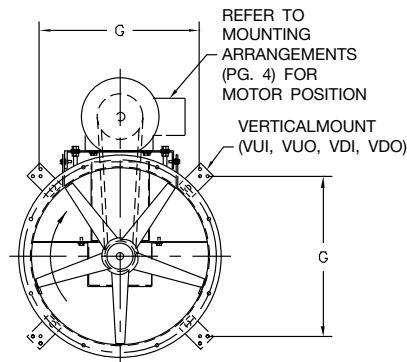
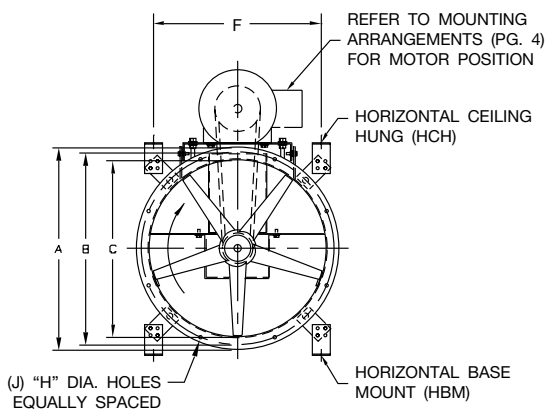
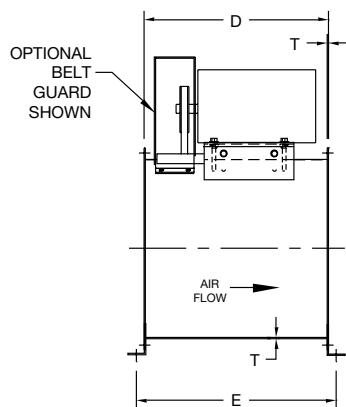

FAN SIZE	A	B	C	D	E	F	G	H	J	T	SHAFT SIZE	MAX. HP	MAX FRAME
14	16.88	15.88	14.25	19.00	21.88	16.00	14.81	0.56	8	14 GA.	3/4	3/4	56
16	19.63	17.88	16.13	19.00	21.88	17.88	16.68	0.56	8	14 GA.	3/4	1	143T
18	21.75	19.88	18.25	19.00	21.88	19.50	18.25	0.56	8	14 GA.	3/4	1 1/2	145T
21	24.75	22.88	21.25	20.69	23.56	21.50	20.25	0.56	8	14 GA.	3/4	2	145T
24	27.75	25.88	24.25	20.69	23.56	23.63	22.44	0.56	8	14 GA.	1	3	184T
30	33.88	32.00	30.38	26.00	28.88	28.00	26.75	0.56	8	12 GA.	1	5	213T
36	40.50	38.38	36.50	27.00	29.88	32.38	31.13	0.56	16	12 GA.	1 3/16	7 1/2	215T
42	46.75	44.63	42.75	31.00	33.88	34.63	33.44	0.69	16	12 GA.	1 7/16	10	215T
48	52.63	50.63	48.63	35.00	37.88	41.00	39.75	0.69	16	12 GA.	1 7/16	10	254T
54	58.63	57.25	54.63	40.00	42.88	45.13	44.00	0.69	16	12 GA.	1 7/16	15	256T

Dimensions shown are in inches unless otherwise indicated.
 Dimensions are not to be used for construction.

Model BSTA / BSTAB

Tubeaxial fans shall be Model BSTA direct drive or BSTAB belt driven as manufactured by Aerovent, Minneapolis, Minnesota.

PERFORMANCE — Fans shall be tested in accordance with AMCA test codes for air moving devices and shall be guaranteed by the manufacturer to deliver rated published performance levels.

CONSTRUCTION — Housings shall be constructed of heavy gauge, continuously welded steel to prevent air leakage. Housings shall include punched inlet and outlet flanges for duct mounting. Motor and bearing supports shall be constructed of heavy-gauge steel and shall be suitably braced to prevent vibration or pulsation.

PROPELLERS — Propellers shall be constructed of cast aluminum blades and hubs. Propellers on direct drive units shall be secured to the motor shaft with a taperlock bushing. Propellers on belt driven units shall be secured to the fan shaft with a taperlock bushing.

SHAFTS (BSTAB Only) — Shafts shall be AISI 1045 cold rolled steel, accurately turned, ground, polished, and ring gauged for accuracy. Shafts shall be sized for the first critical speed of at least 1.43 times the maximum speed.

BEARINGS (BSTAB Only) — Bearings are to be pillow block, heavy-duty, anti-friction, self-aligning, grease lubricated, ball type. Each fan's bearings are sized with a minimum average life, per AFBMA, in excess of 200,000 hours when operating at the maximum RPM of the fan size.

DRIVES (BSTAB Only) — Motor sheaves shall be cast iron, and supplied as either variable pitch or fixed pitch. Drives and belts shall be rated for a minimum of 150% of the required motor HP.

MOTORS — All motors shall be single phase or three phase induction, permanently lubricated, heavy-duty, ball bearing type, closely matched to the fan load and provided at the voltage, phase, hertz, and enclosure as provided on the fan schedule.

FINISH AND COATING — The entire fan assembly, excluding the shaft, shall be thoroughly degreased and deburred before application of a rust-preventative primer. After the fan is completely assembled, a finish coat of paint shall be applied to the entire assembly. The fan shaft shall be coated with a petroleum-based rust protectant. Aluminum components shall be unpainted.

ACCESSORIES — When specified, accessories such as belt guards, motor covers, shaft seals, inlet bells, inlet and outlet guards, mounting brackets, vibration isolators and disconnect switches shall be provided by Aerovent to maintain one source responsibility.

FACTORY RUN TEST — All fans prior to shipment shall be completely assembled and test run as a unit at operating speed or maximum RPM allowed for the particular construction type. Each propeller shall be statically and dynamically balanced in accordance with ANSI/AMCA 204-96 "Balance Quality and Vibration Levels for Fans" to Fan Application Category BV-3, Balance Quality Grade G6.3. Balance readings shall be taken by electronic type equipment in the axial, vertical, and horizontal directions on each of the bearings. Records shall be maintained and a written copy shall be available upon request.

GUARANTEE — The manufacturer shall guarantee the workmanship and materials for its BSTA and BSTAB tubeaxial fans for at least one (1) year from startup or eighteen (18) months from shipment, whichever occurs first.

**PROPELLER FANS | TUBEAXIAL & VANEAXIAL FANS | CENTRIFUGAL FANS & BLOWERS | ROOF VENTILATORS
INDUSTRIAL AIR HANDLERS | AIR MAKE-UP | FIBERGLASS FANS | CUSTOM FANS**



AEROVENT
A Twin City Fan Company

Aerovent

WWW.AEROVENT.COM

5959 Trenton Lane N | Minneapolis, MN 55442 | Phone: 763-551-7500 | Fax: 763-551-7501